

- 01_Block Diagram
- 02_System Setting
- 03_Power Sequence
- 04_EC Pin Define
- 05_HISTORY
- 06_Clock Gen
- 07_Dothan_HOST
- 08_Dothan_PWR_GND
- 09_910GML_HOST_DMI
- 10_910GML_DRAM
- 11_910GML_VGA_LVDS_TV
- 12_910GML_PWR
- 13_910GML_GND
- 14_ICH6-M_Azalia_GPIO_PCI_LAN
- 15_ICH6-M_USB_PCIE_DMI_IDE_SATA
- 16_ICH6-M_PWR_GND
- 17_Onboard DRAM_Bottom A1
- 18_Onboard DRAM_Top A1
- 19_Onboard DRAM_Bottom A2
- 20_Onboard DRAM_Top A2
- 21_DDR2_Termination
- 22_ONBOARD_VGA
- 23_LCD-CONN
- 24_3G Module
- 25_WLAN
- 26_LAN
- 27_RJ45
- 28_Flash_Ctrl_JMF601
- 29_On Board NAND Flash
- 30_USB_PORT
- 31_CARD_READER
- 32_CAMERA
- 33_ALC269-1
- 34_ALC269-2
- 35_ALC269-3
- 36_EC_ENE KB3310
- 37_Switch_SPI ROM_Debug Conn
- 38_KB_Touch Pad
- 39_Thermal Sensor
- 40_LED
- 41_Discharge
- 42_PWR Jack
- 43_Srew Hole
- 44_EMI
- 45_POWER FLOW
- 46_CHARGER
- 47_VCORE
- 48_+3VO_+5VO
- 49_VTT_DDR_+1.8V_HD
- 50_+1.8V
- 51_VCCP
- 52_1.5_2.5V

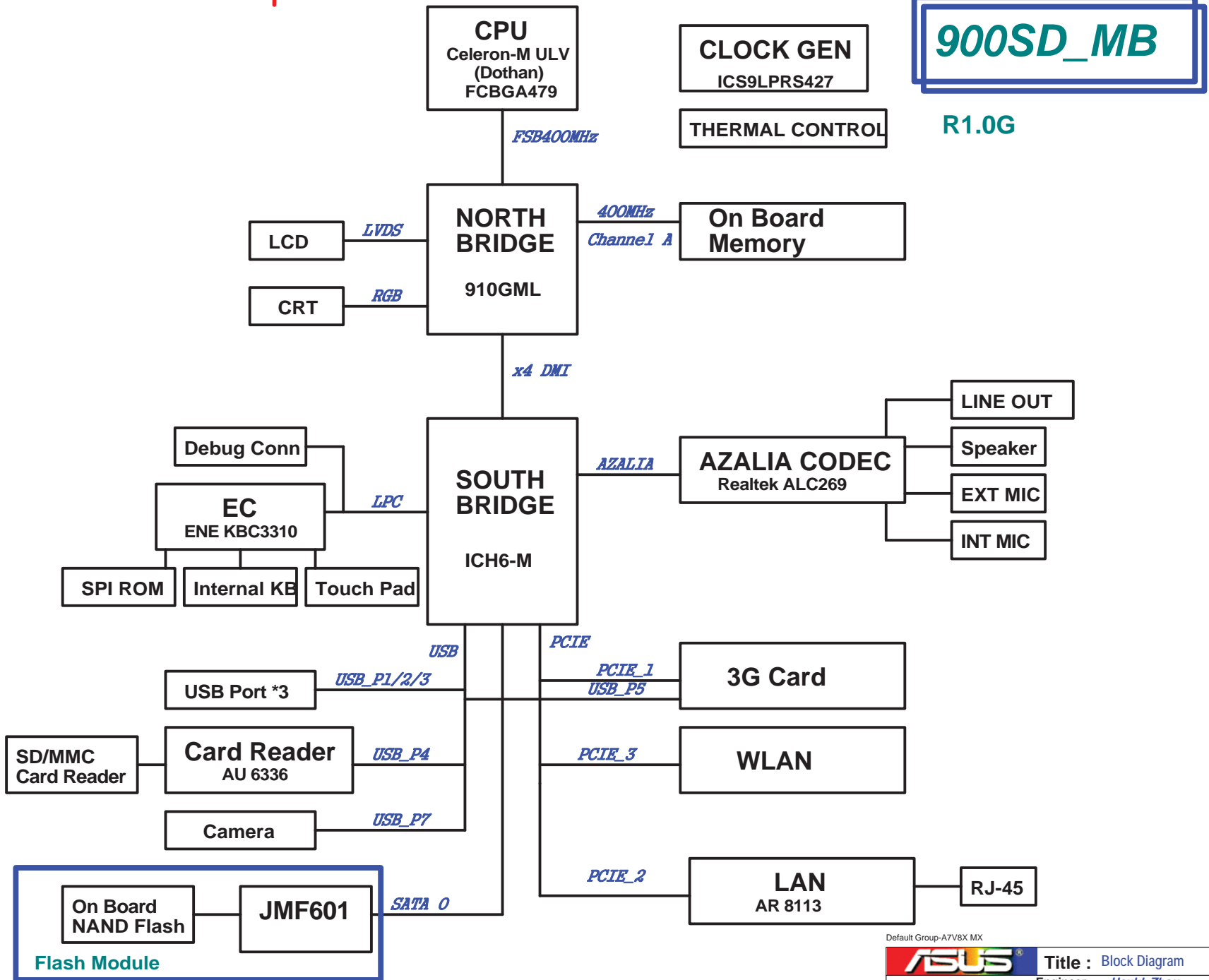

ICH6 GPIO SETTING

Pin	Pin Name	Connect to	Type	Input/Output Set
B7	GPI0/REQ6#	10K Pull +3V	I	fixed as Input only
E8	GPI1 / REQ5#	10K Pull +3V	I	fixed as Input only
D9	GPI2 / PIRQE#	10K Pull +3V	I	fixed as Input only
C7	GPI3 / PIRQF#	10K Pull +3V	I	fixed as Input only
C6	GPI4 / PIRQG#	10K Pull +3V	I	fixed as Input only
M3	GPI5 / PIRQH#	10K Pull +3V	I	fixed as Input only
AD19	GPI6 / BMBUSY#	NB BMBUSY#	I	Input
AE19	GPI7	NC	GPI	fixed as Input only
R1	GPI8	EC KBC_SCI#	GPI	fixed as Input only
C23	GPI9/OC4#	10K Pull +3V	I	Input
D23	GPI10/OC5#	10K Pull +3V	I	Input
W6	GPI11 / SMBALERT#	10K Pull +3V	I	Input
M2	GPI12	NC	GPI	fixed as Input only
R6	GPI13	EC EXTSMI#	GPI	fixed as Input only
C25	GPI14/OC6#	10K Pull +3V	I	Input
C24	GPI15 /OC7#	10K Pull +3V	I	Input
D8	GPO16/GTN6#	NC	O	Output
F6	GPO17 / GNT5#	NC	O	Output
AC21	GPO18 / STP_PC#	Clock GEN STP_PC#	O	Output
AB21	GPO19	WLAN_LED#	GPO	fixed as Output only
AD22	GPO20 / STP_CPU#	STP_CPU#	O	Output
AD20	GPO21	NC	GPO	
NA	GPI022	NA	NA	NA
AD21	GPO23	NC	GPO	fixed as Output only
V3	GPI024	3G	I/O	Output
P5	GPI025	NC	I/O	Output

Pin	Pin Name	Connect to	Type	Input/Output Set
AF17	GPI26/SATA0GP	NC	GPI	(GPI)Input
R3	GPI027	NC	I/O	Output
T3	GPI028	NC	I/O	Output
AE18	GPI29 / SATA1GP	PCBVER0	GPI	(GPI)Input
AF18	GPI30 / SATA2GP	NC	GPI	(GPI)Input
AG18	GPI31 / SATA3GP	PCBVER1	GPI	(GPI)Input
AF19	GPI032 / CLKRUN#	10K Pull +3V	I/O	Input
AF20	GPI033	NC	I/O	Output
AC18	GPI034	NC	I/O	Output
NA	GPI035	NA	NA	NA
NA	GPI036	NA	NA	NA
NA	GPI037	NA	NA	NA
NA	GPI038	NA	NA	NA
NA	GPI039	NA	NA	NA
F7	GPI40 / REQ4#	10K Pull +3V	I	Input
P4	GPI41 / LDRQ1#	NC	I	Input
NA	GPI042	NA	NA	NA
NA	GPI043	NA	NA	NA
NA	GPI044	NA	NA	NA
NA	GPI045	NA	NA	NA
NA	GPI046	NA	NA	NA
NA	GPI047	NA	NA	NA
E7	GPO48 /GNT4#	NC	O	Output
AC25	GPO49 / CPUPWRGD	CPU Power Ok	O	Output

fixed as Output only

Default Group-A7V8X MX

		Title : System Setting	
ASUSTek Computer INC.		Engineer: <i>Kell_Huang</i>	
Size	Project Name		Rev
A3	900SD_MB		R1.0G
Date: Monday, November 10, 2008		Sheet	2 of 51

*This sequence is for Battery Plug-in and no Adapter,
 if Adapter Plug-in, the sequence change to:
 A/D_DOCK_IN-->AC_BAT_SYS-->+3VA-->VSUS_ON-->+3VSB & +5VSB
 -->VSUS_GD-->PM_REMRST#-->PWR_SW#-->PM_PWRBTN-->PM_SUSC#-->PM_SUSB#

Signal	S0/S1	S3	S4/S5	Power	
Only Battery	VSUS_ON	H	H	L	VSB
Adapter In	VSUS_ON	H	H	H	VSB
	SUSB_ON	H	L	L	Main
	SUSC_ON	H	H	L	DUAL

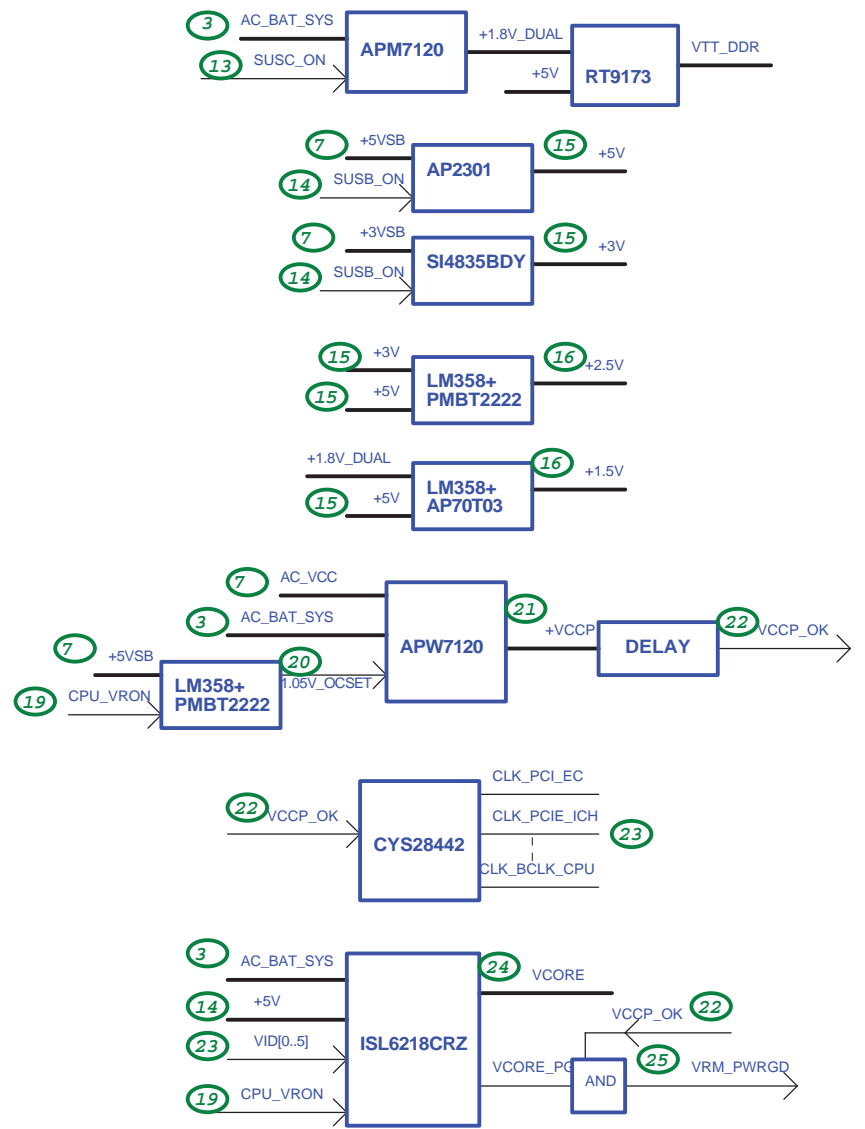
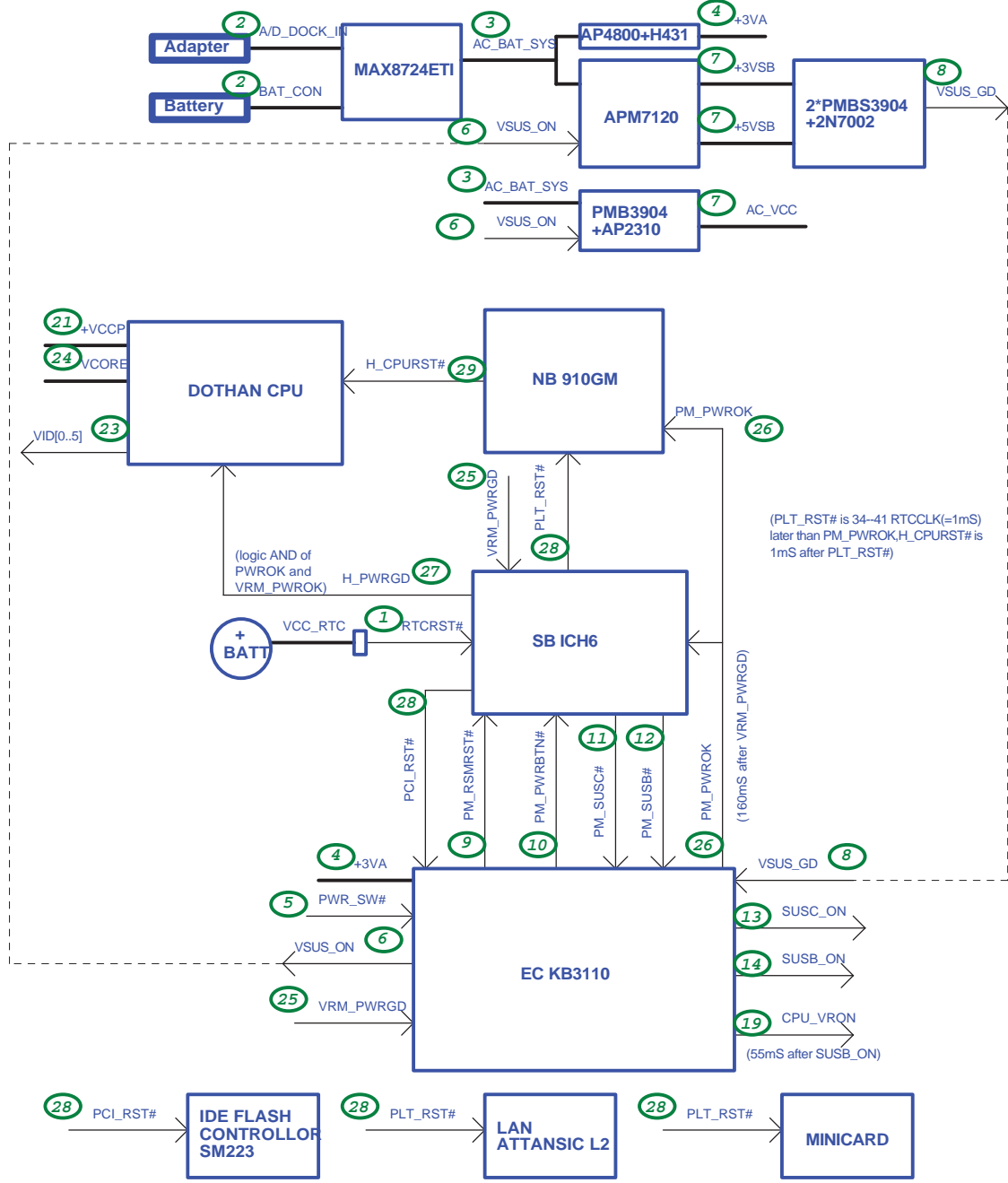

EC KB3310 GPIO SETTING

Pin No.	Pin Name	Signal Name	Type	NOTE
1	GA20	A20GATE	O	A20GATE
2	KBRST#	RC_IN#	O	KBRST#
6	GPI004	CTRL_CAMER_PWR	I	Default : High
13	PCIRST#	PCI_RST#	I	PCI Reset
14	GPI007	N.C	O	Reserved
15	GPI008	EXTSMH#	O	EXTSMH#, 10K Pull +3VSUS
16	GPI00A	LID_EC#	I	LID_EC#, *
17	GPI00B	LCD_CSB	O	LCD chip select
18	GPI00C	LCD_SDA	I/O	LCD Data
19	GPI00D	DISTP_SW#	I	Touch Pad Disabled, *
20	SC#	KBC_SC#	O	KBC_SC#, 10K Pull +3VSUS
21	PWM1	BL_PWM_DA	O	LCD Light Switch
23	PWM2	LCD_SCL	O	LCD clock
25	GPI011	PM_PWRBTN#	OD	Power Button to SB, *
26	FANPWM1	FAN0_PWM	O	CPU Fan(Unused)
27	FANPWM2	FAN1_PWM	O	VGA Fan(Unused)
28	FANFB1	FAN0_TACH	I	CPU FanTach(Unused)
29	FANFB2	FAN1_TACH	I	VGA FanTach(Unused)
30	GPI016	E51_TX	O	RS232 debug port
31	GPI017	N.C	O	Reserved
32	GPI018	PWR_SW#	I	power button, *
34	GPI019	MAIL_LED#	O	Mail LED(Unused)
36	GPI01A	CTRL_Minicard_PWR	O	Default : High
38	CLKRUN#	N.C	O	Reserved
39	KSO0	KSO0	O	For Keyboard interface
40	KSO1	KSO1	O	For Keyboard interface
41	KSO2	KSO2	O	For Keyboard interface
42	KSO3	KSO3	O	For Keyboard interface
43	KSO4	KSO4	O	For Keyboard interface
44	KSO5	KSO5	O	For Keyboard interface
45	KSO6	KSO6	O	For Keyboard interface
46	KSO7	KSO7	O	For Keyboard interface
47	KSO8	KSO8	O	For Keyboard interface
48	KSO9	KSO9	O	For Keyboard interface
49	KSO10	KSO10	O	For Keyboard interface
50	KSO11	KSO11	O	For Keyboard interface
51	KSO12	KSO12	O	For Keyboard interface
52	KSO13	KSO13	O	For Keyboard interface
53	KSO14	KSO14	O	For Keyboard interface
54	KSO15	KSO15	O	For Keyboard interface
55	KSI0	KSI0	I	For Keyboard interface
56	KSI1	KSI1	I	For Keyboard interface
57	KSI2	KSI2	I	For Keyboard interface
58	KSI3	KSI3	I	For Keyboard interface
59	KSI4	KSI4	I	For Keyboard interface
60	KSI5	KSI5	I	For Keyboard interface
61	KSI6	KSI6	I	For Keyboard interface
62	KSI7	KSI7	I	For Keyboard interface
63	AD0	P_PMON_10	I	Sense Power Loading
64	AD1	BAT_IN	I	sense Battery
65	AD2	N.C	I	Reserved
66	AD3	N.C	I	Reserved
68	GPO3C	DOC	O	Trigger Clock Gen

<http://hobi-elektronika.net>

Pin No.	Pin Name	Signal Name	Type	NOTE
70	GPO3D	LCD_BACKOFF#	O	LCD_BACKOFF#
71	GPO3E	CLK_PWRSERVE#	O	Active when BAT_IN=1 and AC_OK=0(Unused)
72	GPO3F	BAT_LL#	O	Battery Low Low
73	GPI040	AC_OK	I	AC Adaptor Plug in
74	GPI041	PM_RSMRST#	O	10K Pull GND
75	GPI042	N.C	O	Reserved
76	GPI043	N.C	O	Reserved
77	SCL1	SMB0_CLK	I/OD	4.7K Pull +3VA_EC
78	SDA1	SMB0_DAT	I/OD	4.7K Pull +3VA_EC
79	SCL2	SMB1_CLK	I/OD	10K Pull +3VS
80	SDA2	SMB1_DAT	I/OD	10K Pull +3VS
81	KSO16	N.C	O	Reserved
82	KSO17	N.C	O	Reserved
83	PSCLK1	N.C	O	Reserved
84	PSDAT1	N.C	O	Reserved
85	PSCLK2	N.C	O	Reserved
86	PSDAT2	N.C	O	Reserved
87	PSCLK3	TP_CLK	I/OD	10K Pull +3VS
88	PSDAT3	TP_DAT	I/OD	10K Pull +3VS
89	GPI050	BATSEL_3S	O	Battery series. Hi:3S, Lo:4S(Unused)
90	GPI052	CHG_LED_UP#	O	charger LED
91	GPI053	CTRL_L2_PWR	O	Default : High
92	GPI054	PWR_LED_UP	O	EC H/W blinking
93	GPI055	SCRL_LED#	O	EC H/W controls
95	GPI056	PWR4G_SW#	I	*
97	GPXOA00	SPI_MODE#	O	*HW Strap for SPI Flash deExternal Pull Down 100K ohm to GND*
98	GPXOA01	SUSC_ON	O	
99	GPXOA02	VSUS_ON	O	
100	GPXOA03	CPU_VRON	O	
101	GPXOA04	SUSB_ON	O	
102	GPXOA05	ICH8_PWROK	O	
103	GPXOA06	N.C	O	Reserved
104	GPXOA07	CHG_EN#	O	Battery charging enabled
105	GPXOA08	PRECHG	O	
106	GPXOA09	SPI_WP#	O	
107	GPXOA10	OP_SD#	O	Audio OP
108	GPXOA11	BAT_LEARN	O	
109	GPXID0	BATSEL_2P#	O	Battery parallel. Hi:1P, Lo:2P-3P
110	GPXID1	N.C	O	Reserved
112	GPXID2	THRO_CPU	O	Active if Battery Temperature is Pull Down 100K ohm to GND
114	GPXID3	SUSB#	I	Pull Down 100K ohm to GND
115	GPXID4	SUSC#	I	Pull Down 100K ohm to GND
116	GPXID5	CPUPWR_GD	I	10K Pull +3VS
117	GPXID6	VSUS_GD	I	Disabled **
118	GPXID7	N.C	O	Reserved
121	GPI057	INTERNET#	I	*
126	SPICLK	SPI_CLK	O	SPI Clock
127	GPI059	N.C	O	Reserved

EC KB3310 Other Pin SETTING

Pin No.	Pin Name	Signal Name	Type	NOTE
3	SERIRQ	INT_SERIRQ	I/OD	8.2K Pull +3VS
4	LFRAME#	LPC_FRAME#	I	
5	LAD3	LPC_AD3	I/O	
7	LAD2	LPC_AD2	I/O	
8	LAD1	LPC_AD1	I/O	
9	VCC	+3VA_EC	P	
10	LAD0	LPC_AD0	I/O	
11	GND	GND	P	
12	PCICLK	CLK_PCJ_EC	I	
22	VCC	+3VA_EC	P	
24	GND	GND	P	
33	VCC	+3VA_EC	P	
35	GND	GND	P	
37	ECRST#	EC_RST#	I	Add 100K ohm to GND
67	AVCC	+3VACC	P	
69	AGND	AGND	P	
94	GND	GND	P	
96	VCC	+3VA_EC	P	
111	VCC	+3VA_EC	P	
113	GND	GND	P	
119	RD#	SPI_SO	I	
120	WR#	SPI_SI	O	
112	XCLKI	32KXCLKI	I	
123	XCLKO	32KXCLKO	O	
124	V18R	K_V18R		Reserved 1uF to GND
125	VCC	+3VA_EC	P	
128	SPICS#	SPI_CE#	O	

Default Group-A7V8X MX

		Title : EC Pin Define	
ASUSTek Computer INC.		Engineer: Keli Huang	
Size	Project Name	Rev	
A3	900SD_MB	R1.0G	
Date: Monday, November 10, 2008		Sheet	4 of 51

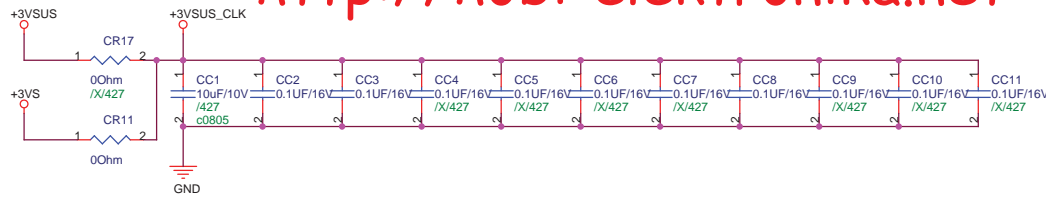
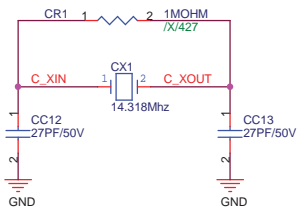

N/A for Debug, pR will /X

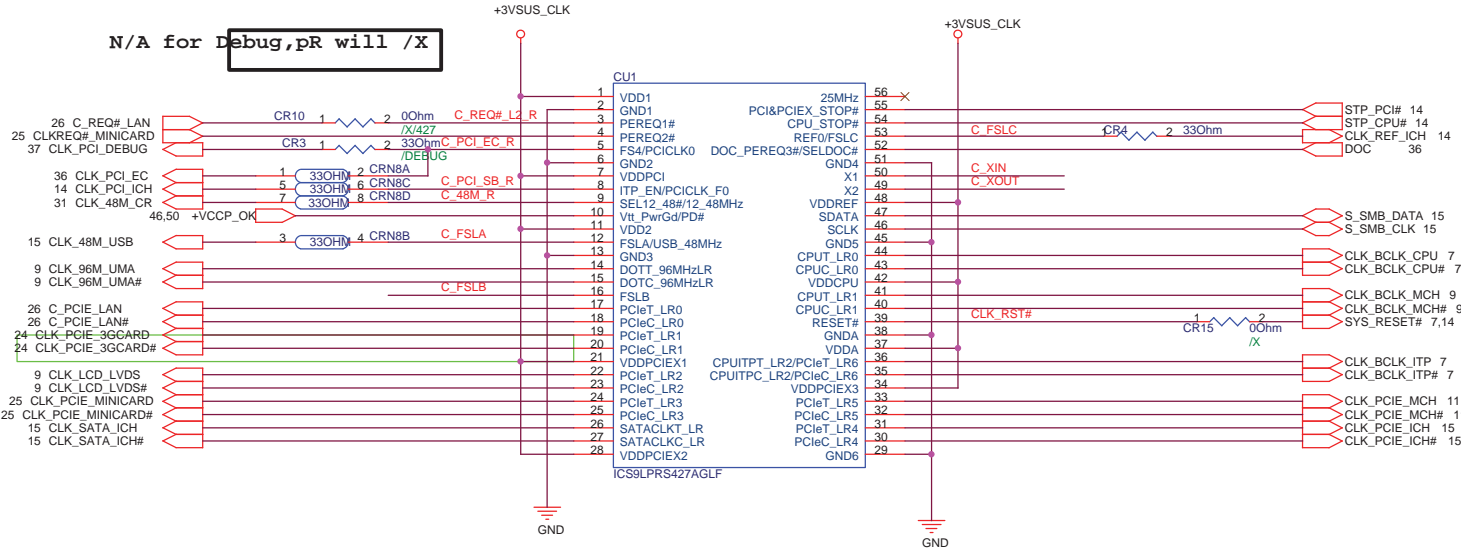

1:Disable
0:Enable

PEREQ1:PCIEx0 & PCIEx1
PEREQ2:PCIEx2 & PCIEx3 & SATA
PEREQ3:PCIEx4 & PCIEx5 & PCIEx6

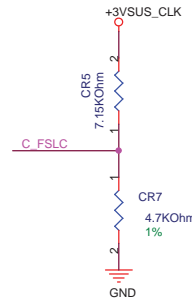
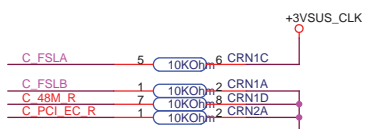
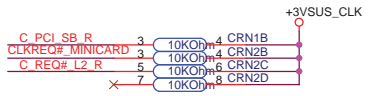
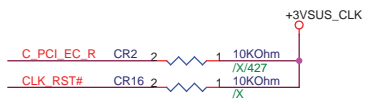

CLK_FSLC	Strapping Define
1.8V-3.3V	enter Test Mode
0.7V-1.8V	FSB trap High
0V-0.35V	FSB trap Low

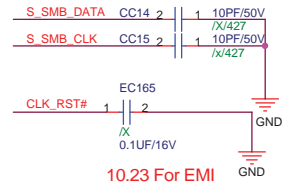

10.23 For EMI

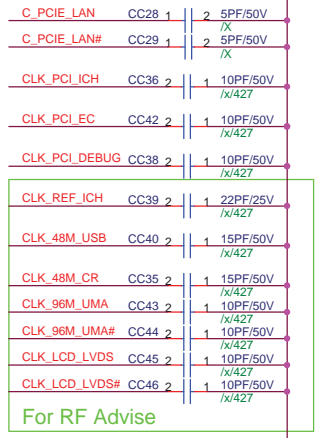
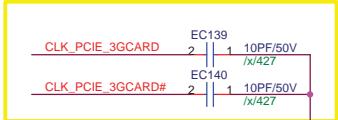

For RF Advise

FSLC	FSLB	FSLA	CPU(MHZ)
0	0	1	133.33
1	0	1	100

Default Group-A7V8X MX

ASUS Title : Clock Gen_ICS9LPR427

ASUSTek Computer INC. Engineer: *Haitao Zhou*

Size: A3 Project Name: **900SD_MB** Rev: R1.0G

Date: Monday, November 10, 2008 Sheet 6 of 51

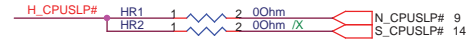
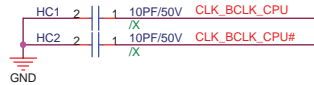
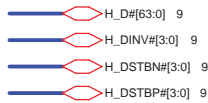

Pinout table for U16A (860555INT_FCBGA479) showing connections for data, address, and control signals.

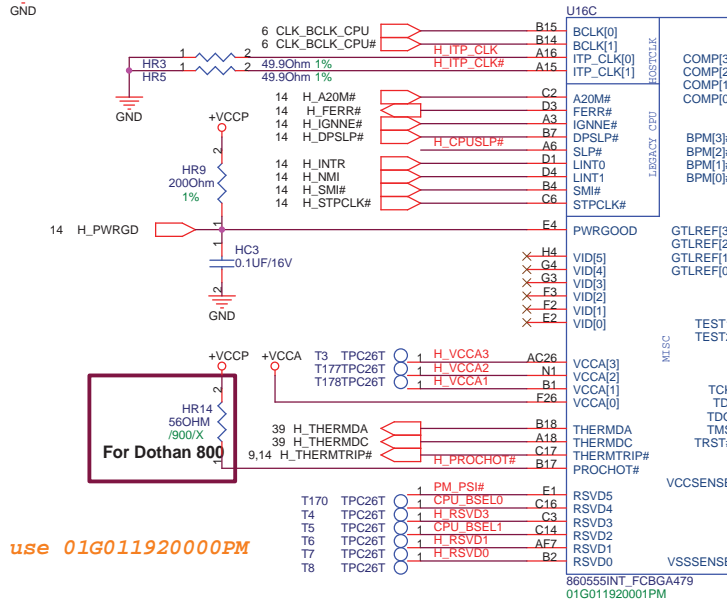

For Dothan 800

U16 use 01G01192000PM

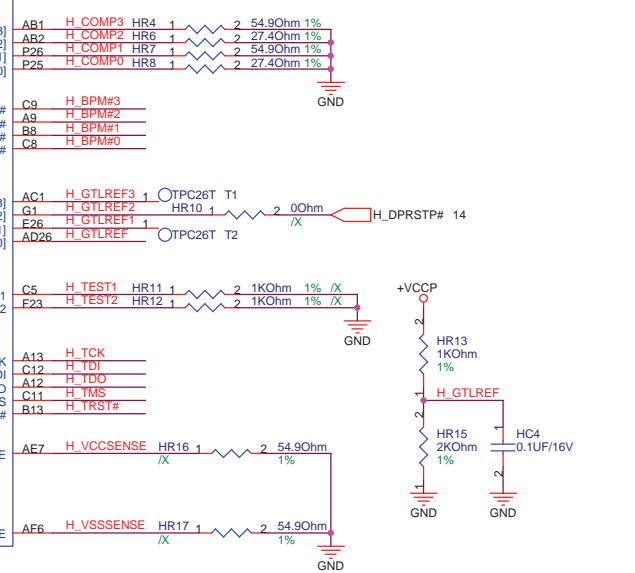

Pinout table for U16B (860555INT_FCBGA479) showing connections for address and control signals.

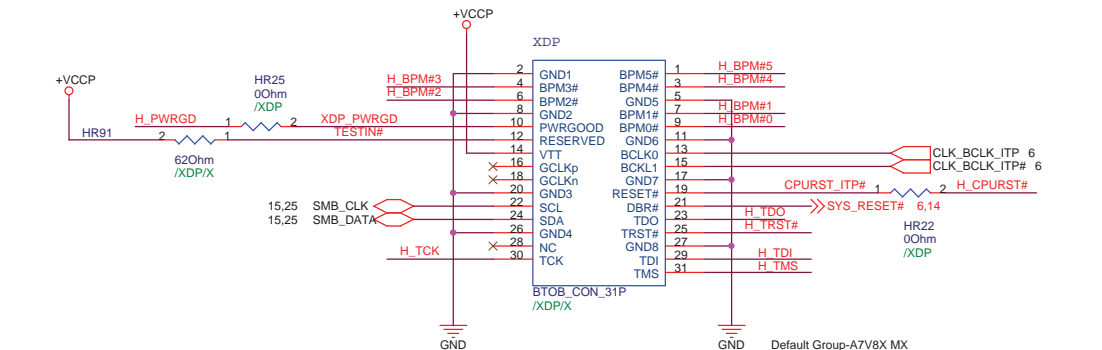
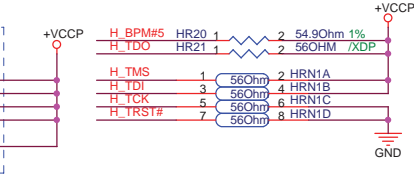
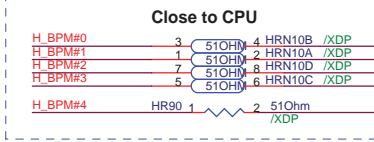
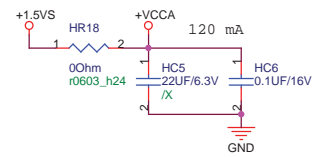
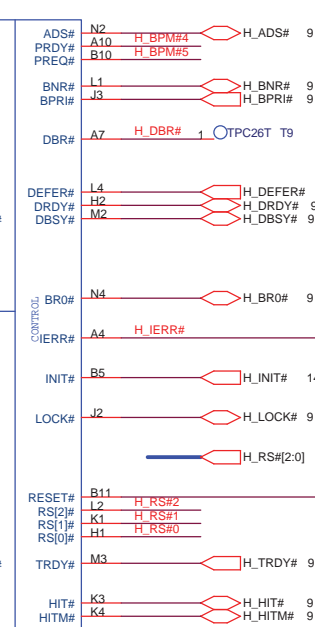

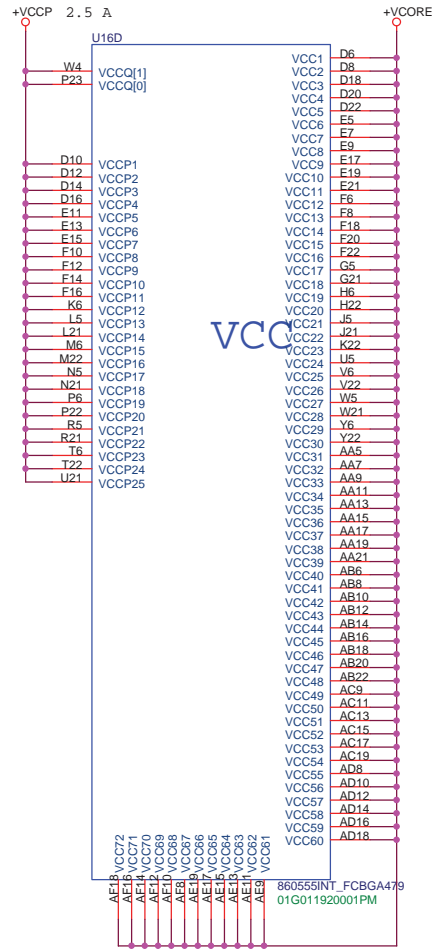

Celeron-M(Dothan) ULV max 7 A

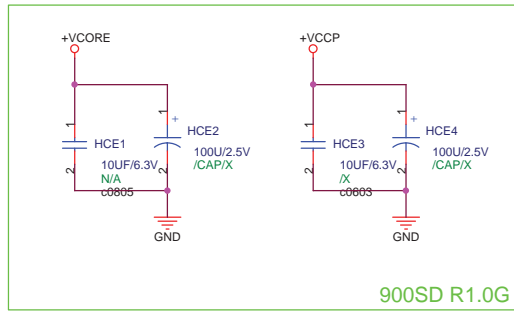

900SD R1.0G

0.1U All X7R

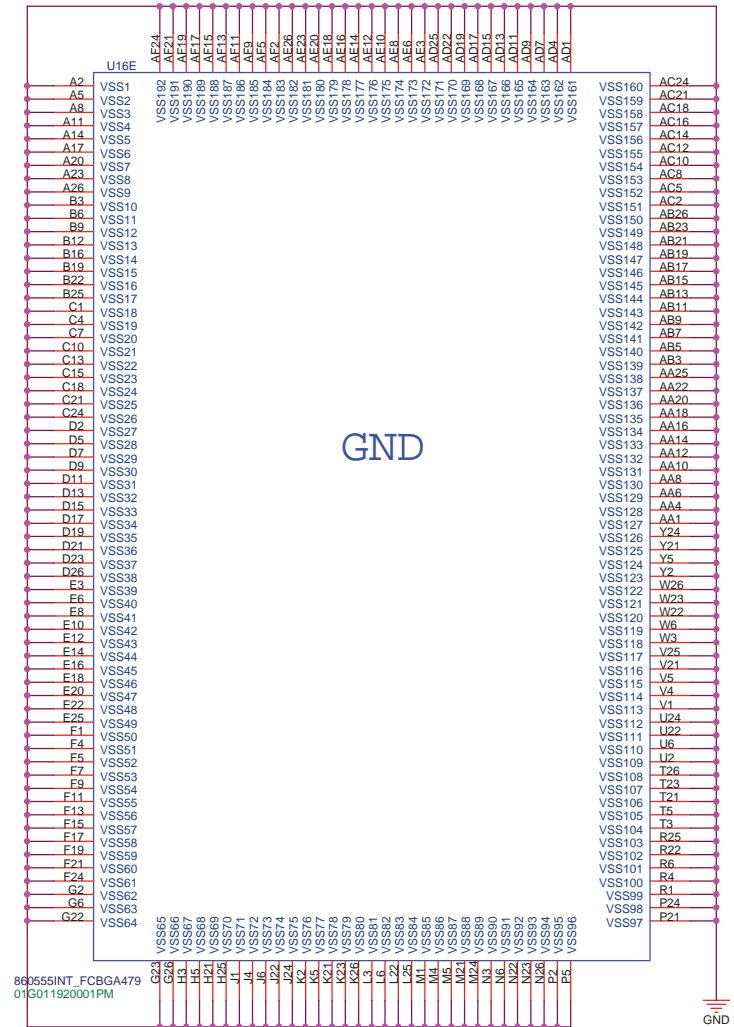
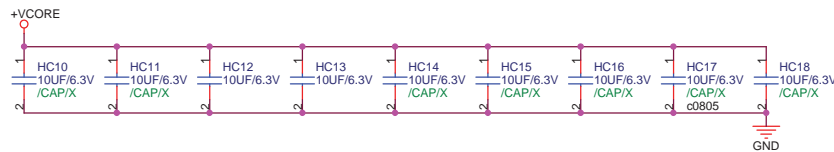
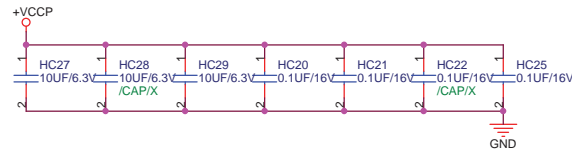
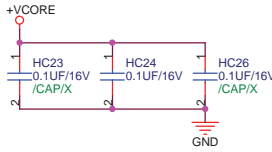

GND

Default Group-A7V8X MX

ASUS		Title : Dothan_PWR_GND	
ASUSTek Computer INC.		Engineer: Kel_Huang	
Size	Project Name		Rev
A3	900SD_MB		R1.0G
Date: Monday, November 10, 2008	Sheet 8 of 51		

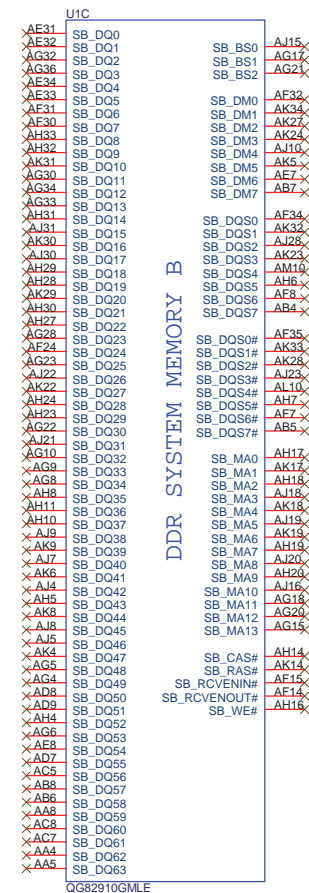
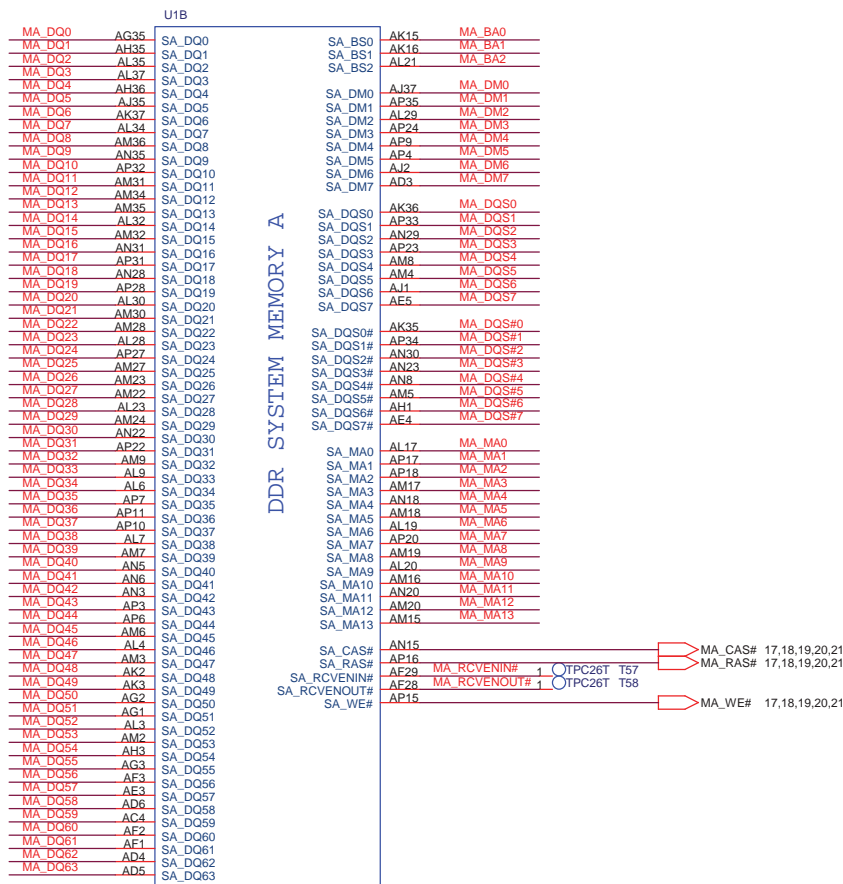
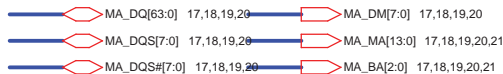

Default Group-A7V8X MX

ASUS		Title : 910GML_DRAM	
ASUSTek Computer INC.		Engineer: Kell_Huang	
Size	Project Name		Rev
A3	900SD_MB		R1.0G
Date: Monday, November 10, 2008	Sheet	10 of 51	

SDVOCTRL_DATA Int PD
 0 : No SDVO device
 1 : SDVO device present

U1 use 02G010007610

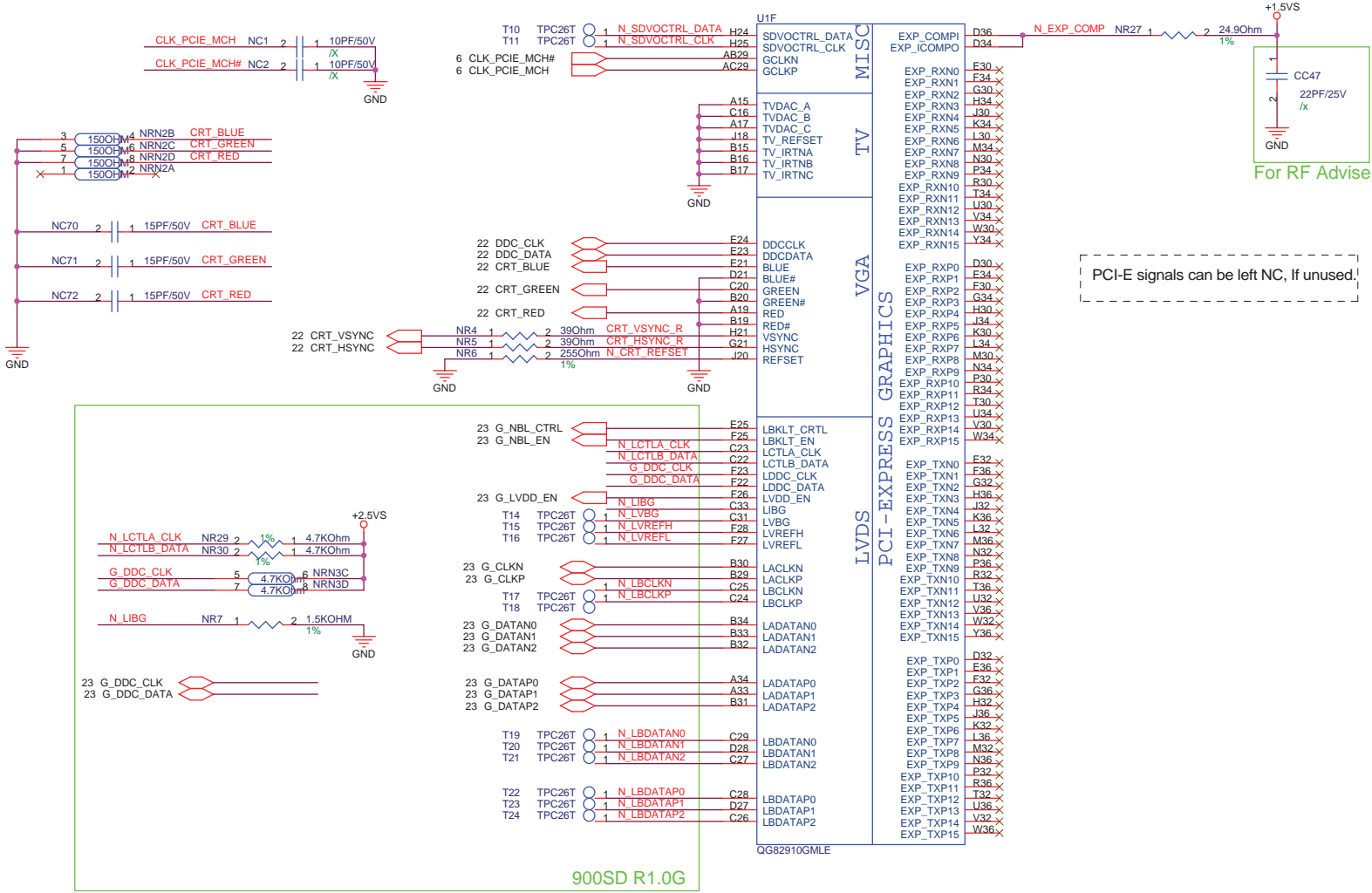

PCI-E signals can be left NC, if unused!

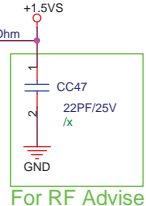

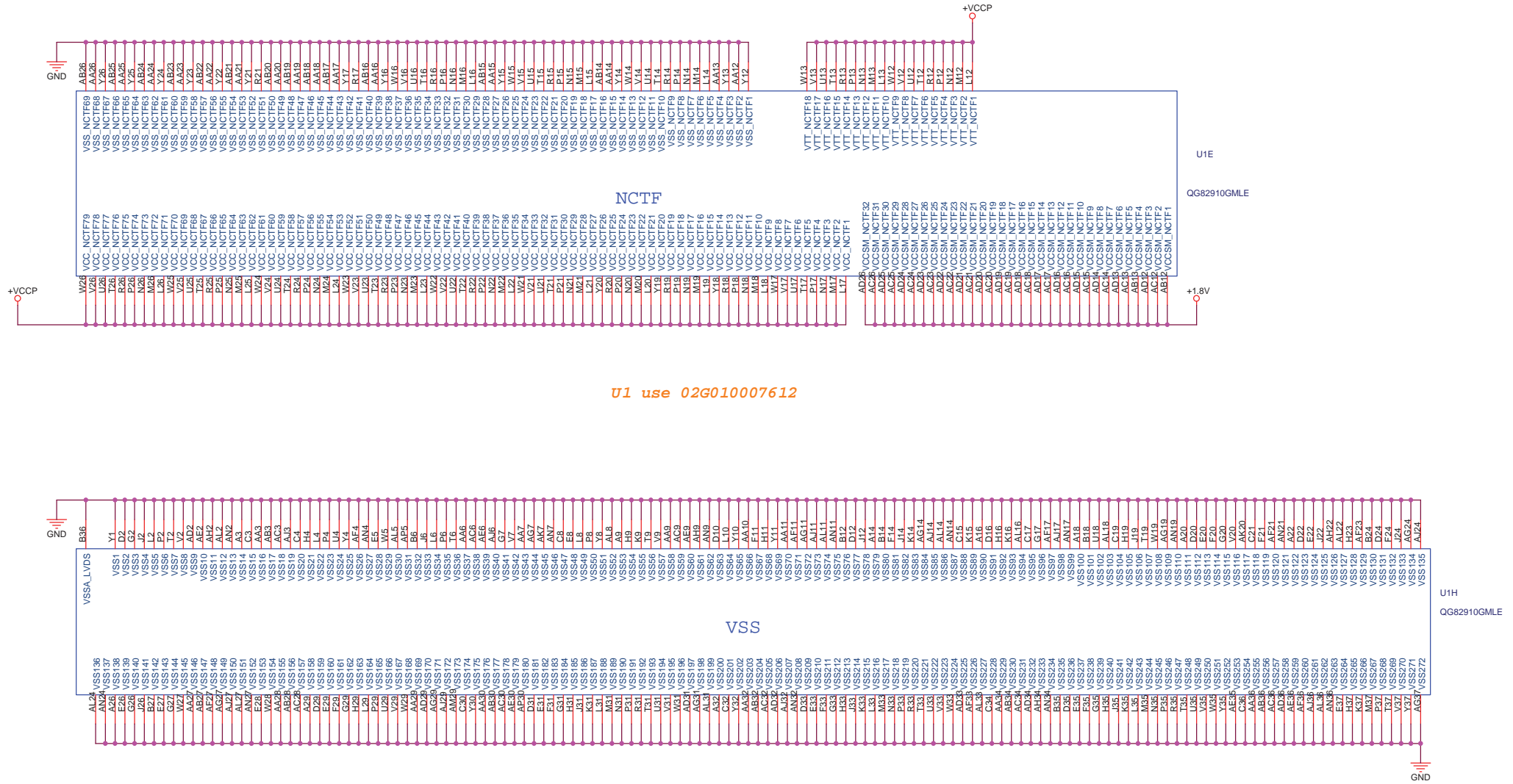

U1 use 02G010007612

Default Group-A7V8X MX

		Title : 910GML_GND	
ASUSTek Computer INC.		Engineer: Kel_Huang	
Size	Project Name		Rev
A3	900SD_MB		R1.0G
Date: Monday, November 10, 2008	Sheet	13	of 51

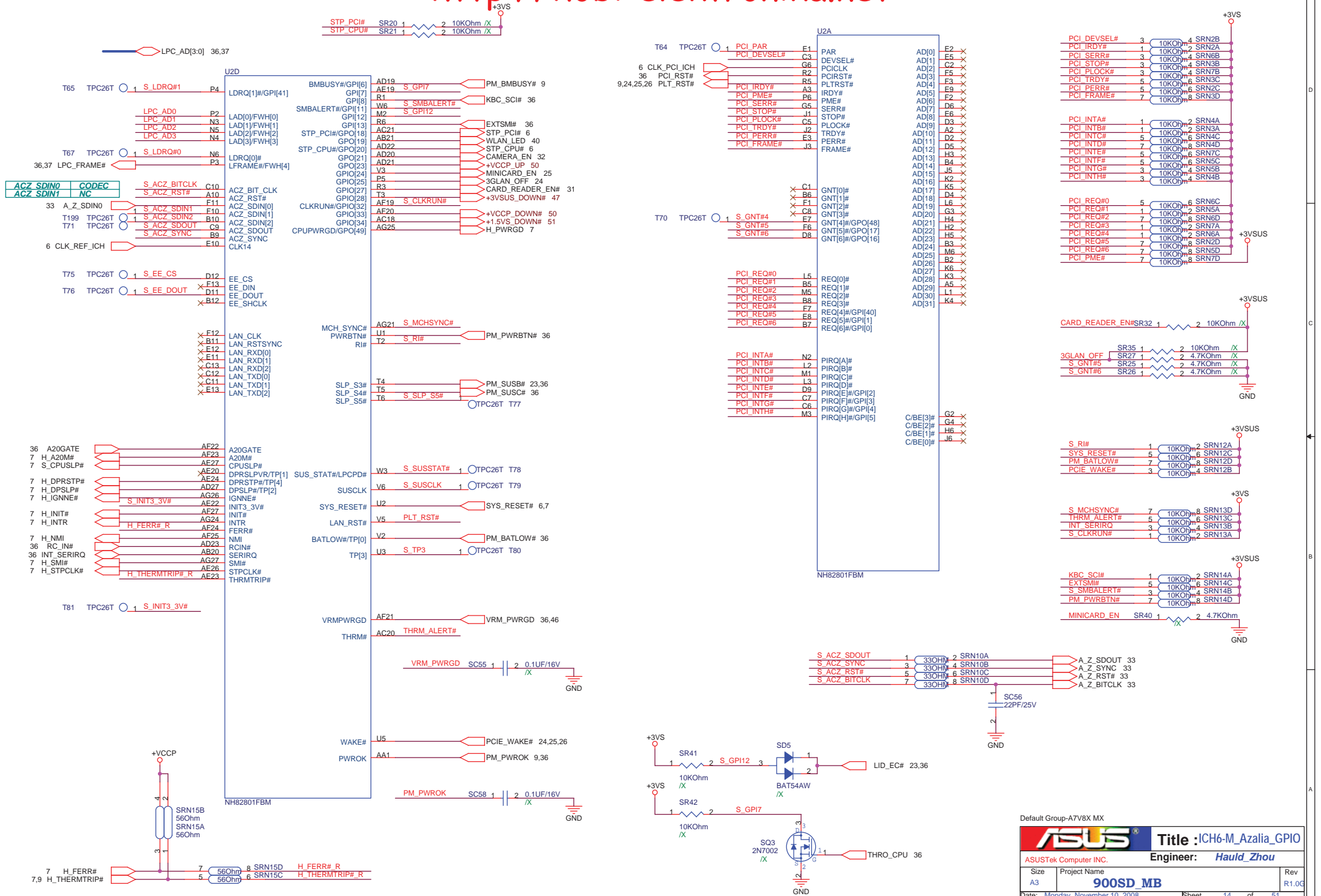

Default Group-A7V8X MX

ASUS		Title :ICH6-M_Azalia_GPIO	
ASUSTek Computer INC.		Engineer: Hauld Zhou	
Size A3	Project Name 900SD_MB	Rev R1.0G	
Date: Monday, November 10, 2008	Sheet 14	of 51	

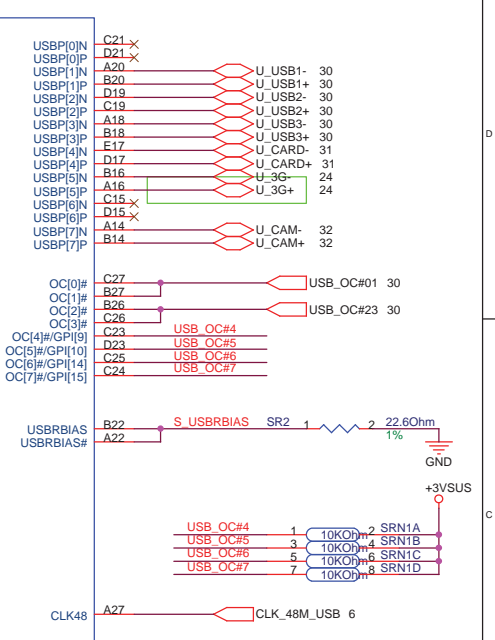
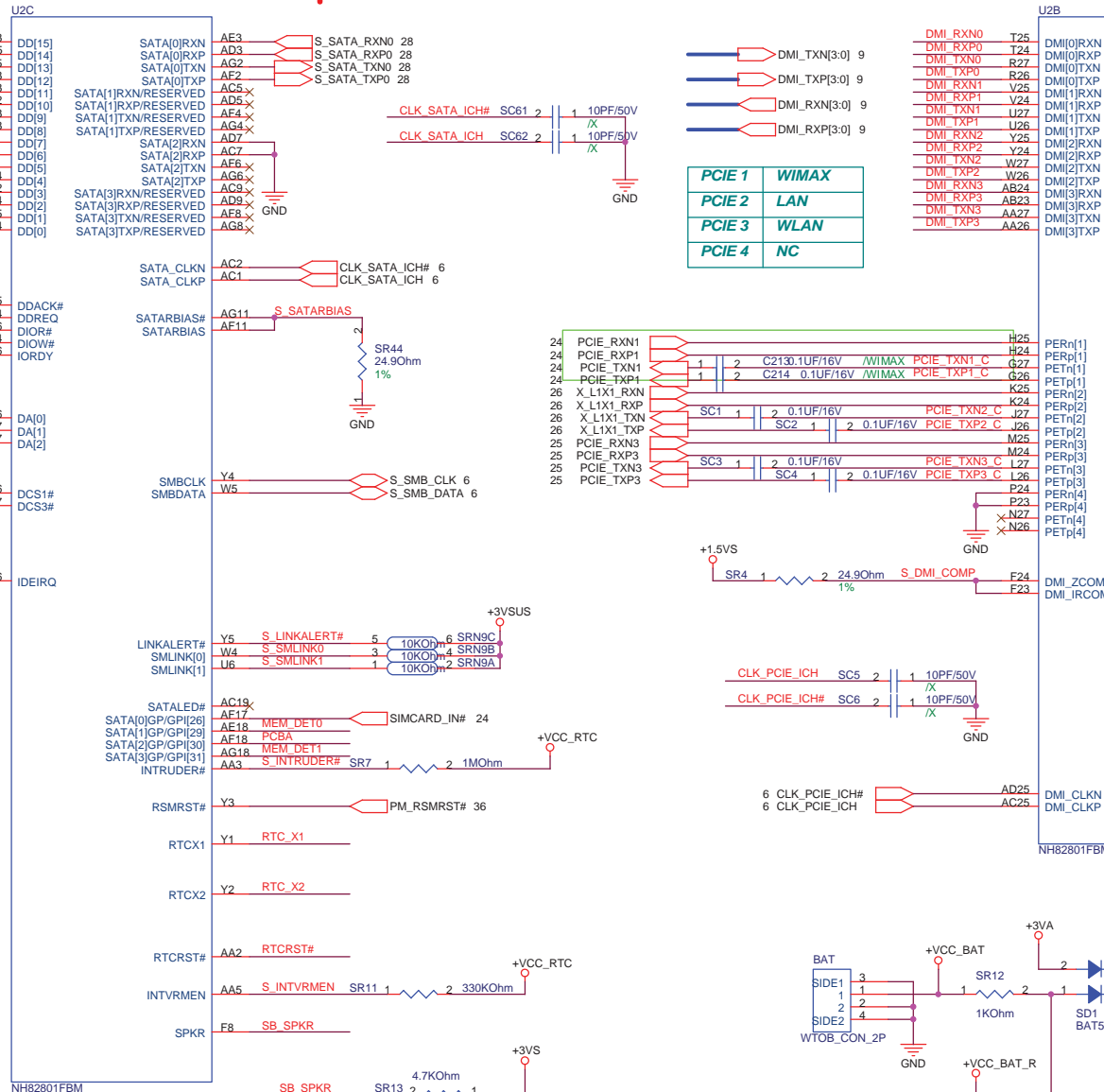

USB 0	NC
USB 1	USB Conn
USB 2	USB Conn
USB 3	USB Conn
USB 4	Card Reader
USB 5	3G
USB 6	NC
USB 7	Camera

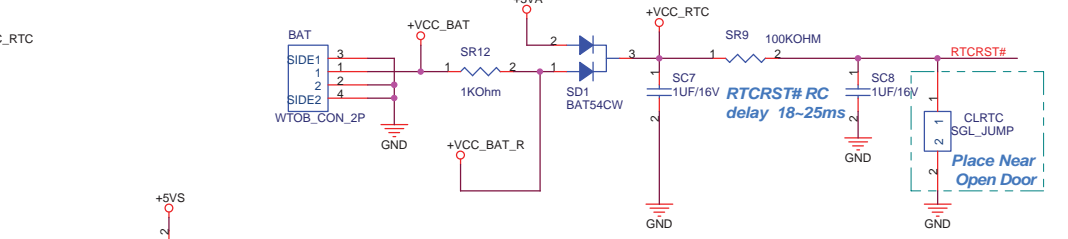
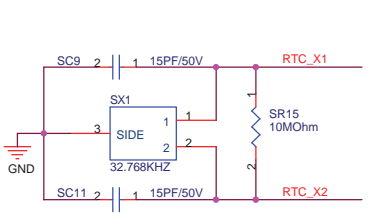
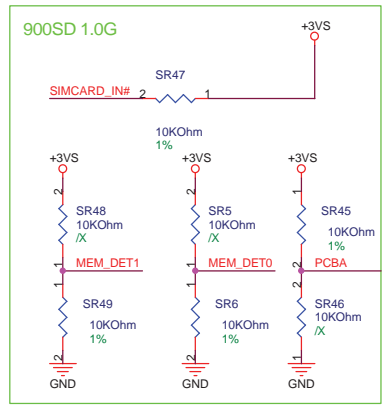

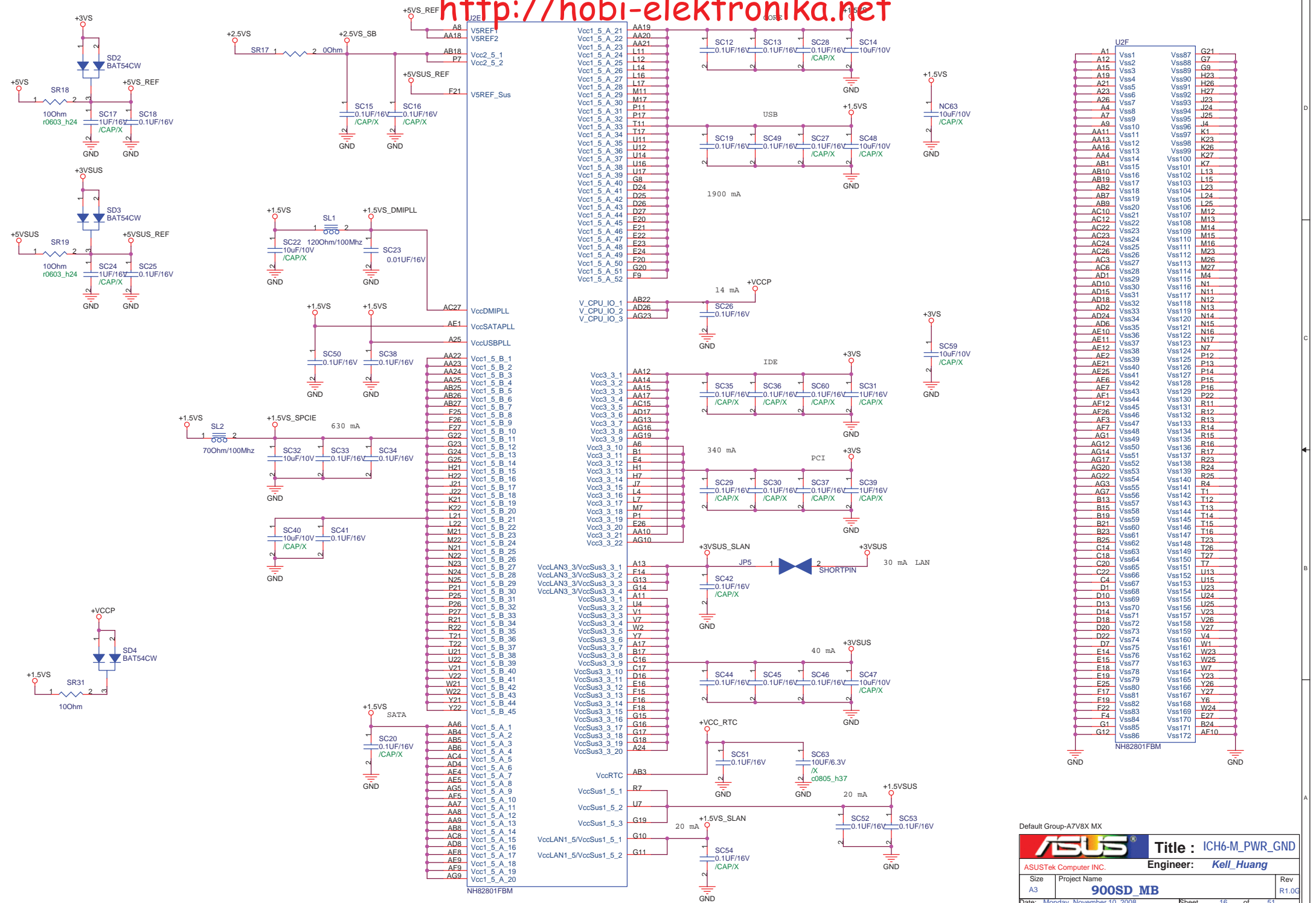

Default Group-A7V8X MX

ASUS		Title : ICH6-M_PWR_GND	
ASUSTek Computer INC.		Engineer: Kell Huang	
Size A3	Project Name 900SD_MB	Rev R1.0G	
Date: Monday, November 10, 2008	Sheet 16 of 51		

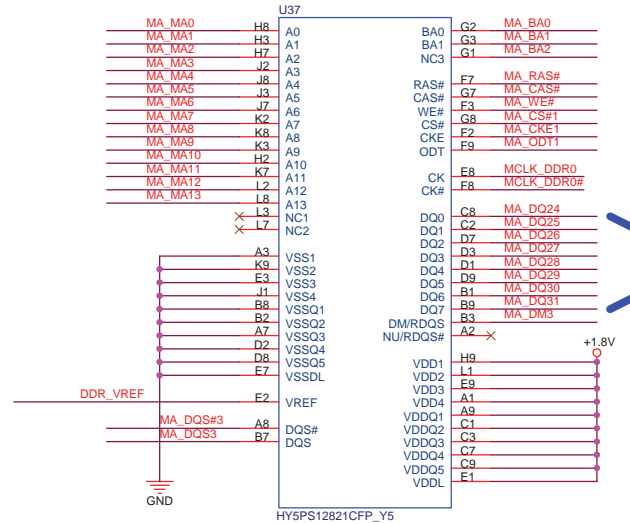
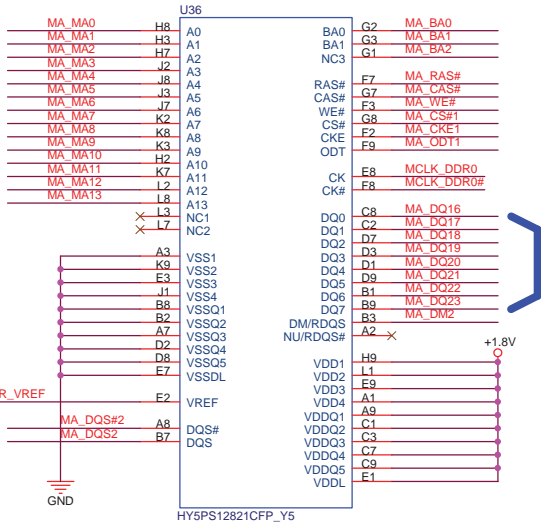
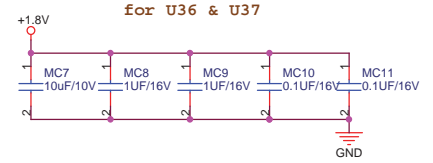
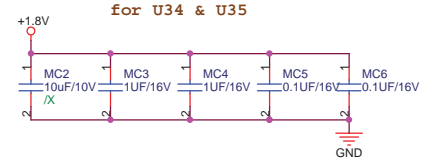
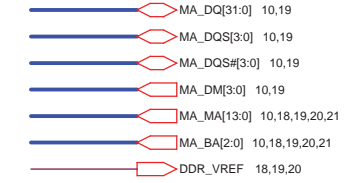
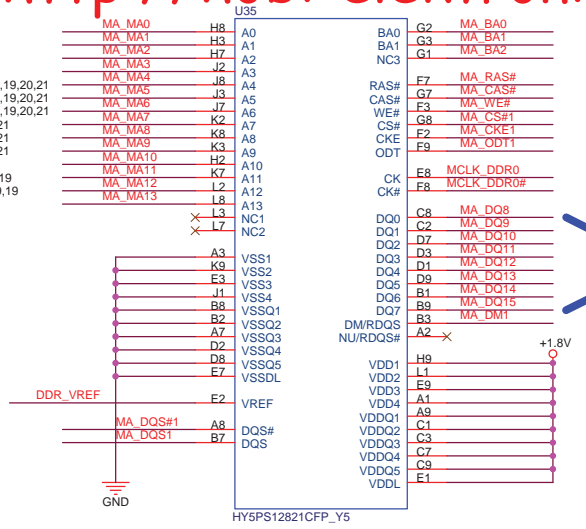
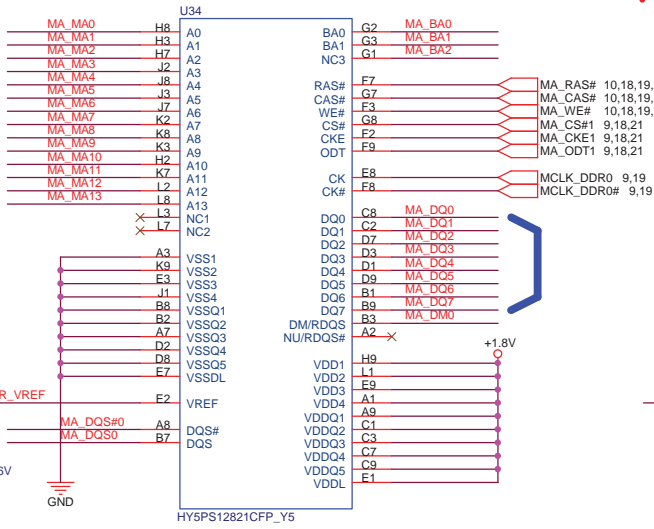

Default Group-A7V8X MX

ASUS		Title : Onboard_DRAM_1	
ASUSTek COMPUTER INC		Engineer: Fehling_wang	
Size	Project Name		Rev
A3	900SD_MB		R1.0C
Date: Monday, November 10, 2008		Sheet	17 of 51

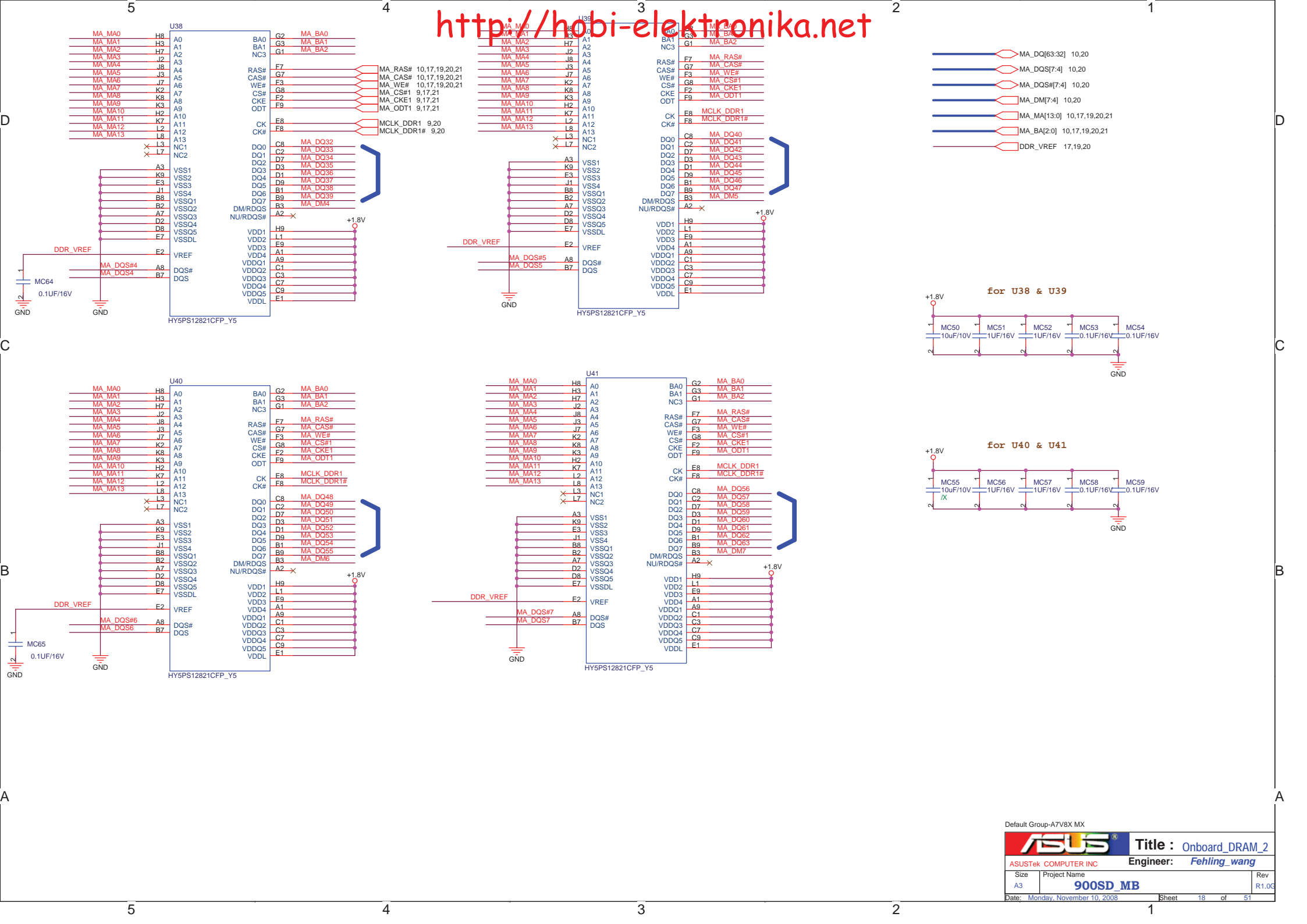

- MA_DQ[63:32] 10,20
- MA_DQS[7:4] 10,20
- MA_DQS#[7:4] 10,20
- MA_DM[7:4] 10,20
- MA_MA[13:0] 10,17,19,20,21
- MA_BA[2:0] 10,17,19,20,21
- DDR_VREF 17,19,20

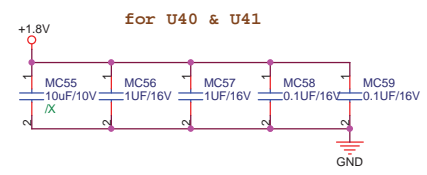
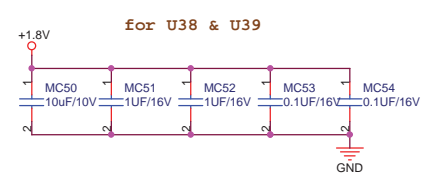

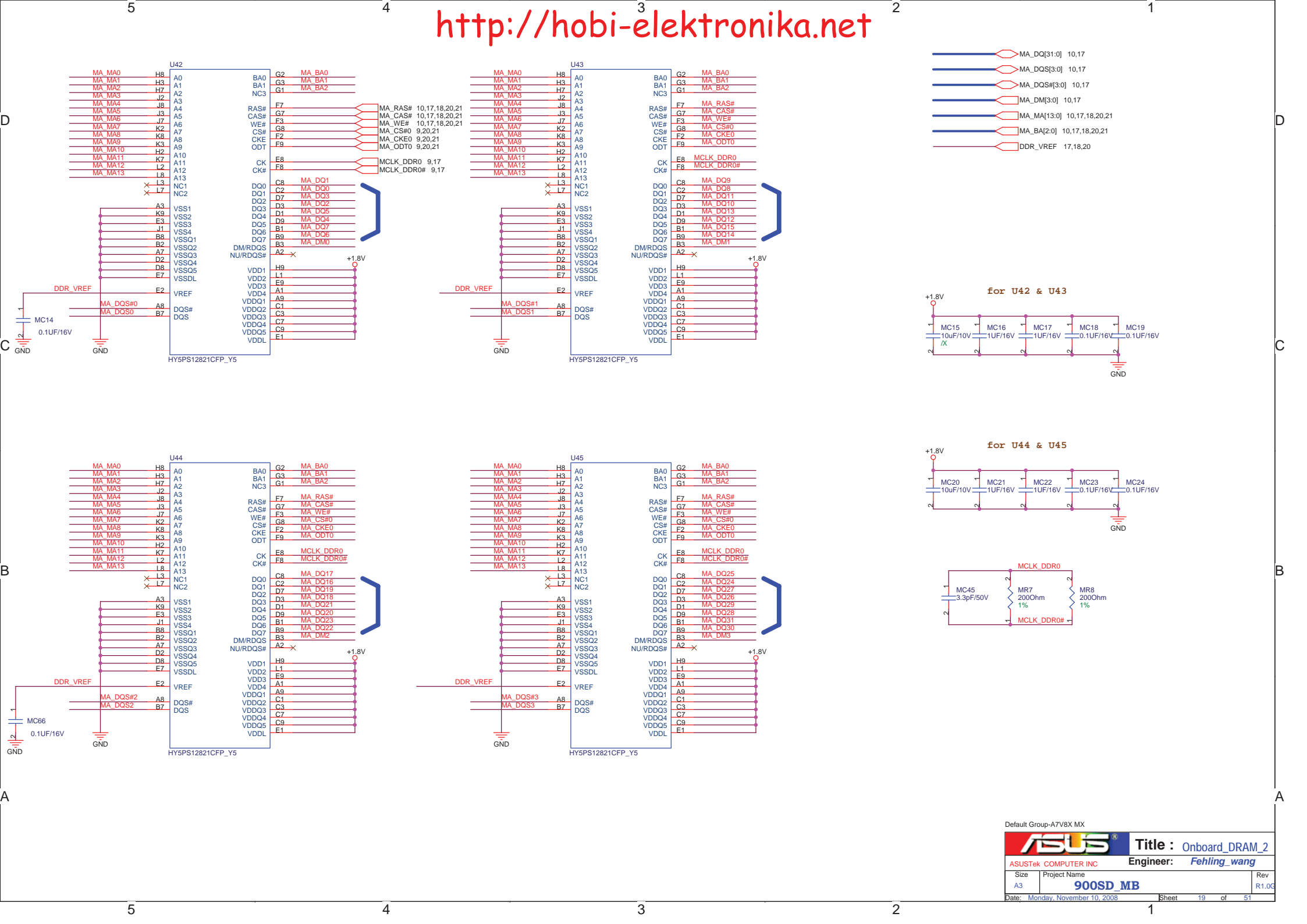

- MA_DQ[31:0] 10,17
- MA_DQS[3:0] 10,17
- MA_DQS# [3:0] 10,17
- MA_DM[3:0] 10,17
- MA_MA[13:0] 10,17,18,20,21
- MA_BA[2:0] 10,17,18,20,21
- DDR_VREF 17,18,20

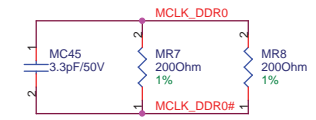
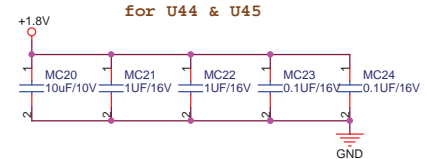
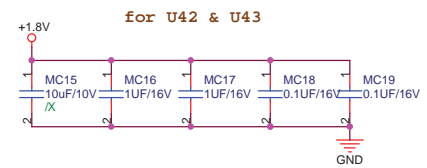

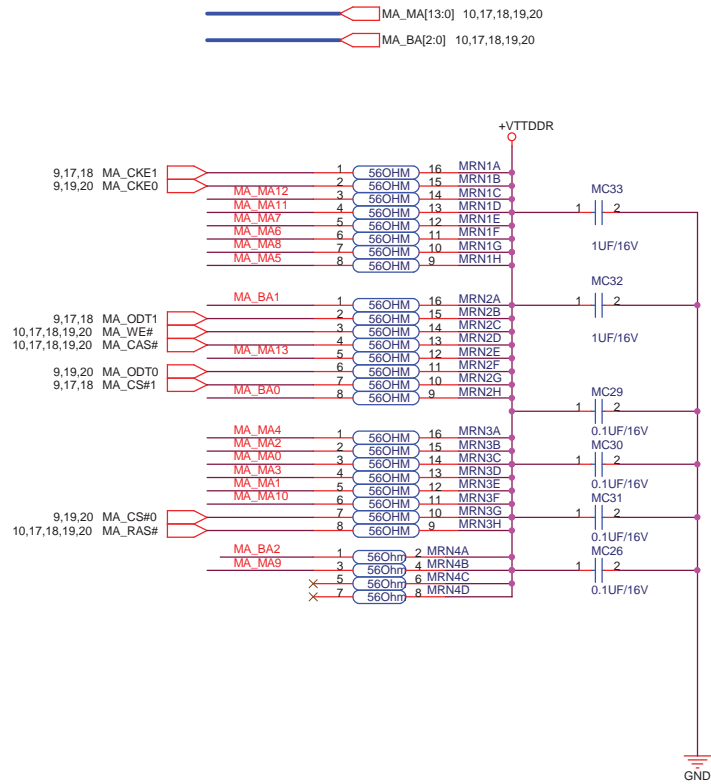

Default Group-A7V8X MX

ASUS		Title : DDR2_Termination	
ASUSTek Computer INC.		Engineer: <i>Kell_Huang</i>	
Size	Project Name	Rev	
A3	900SD_MB	R1.0G	
Date: Monday, November 10, 2008		Sheet	21 of 51

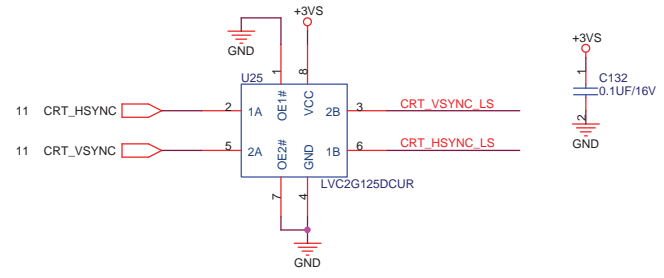
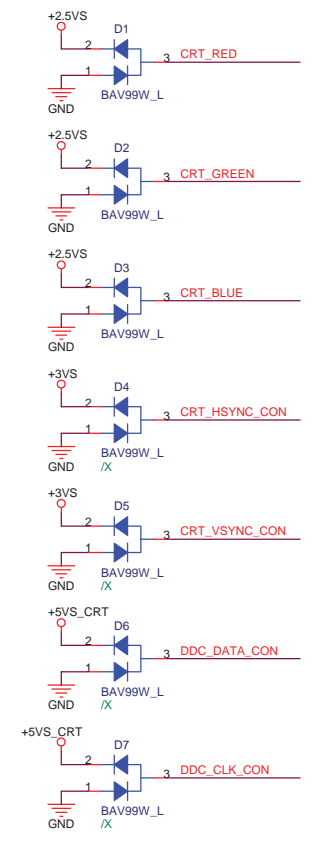
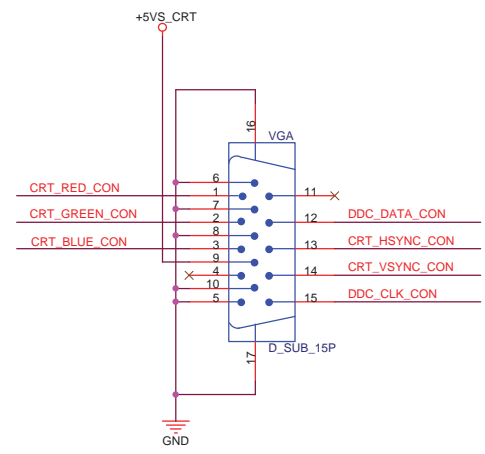
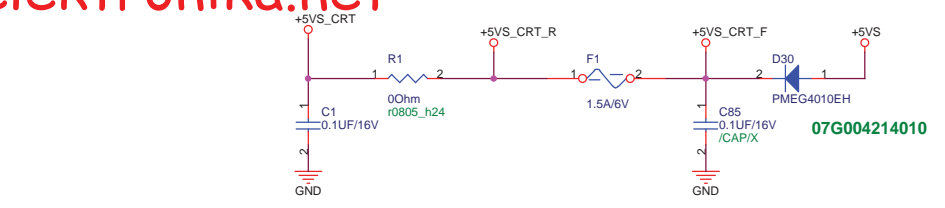
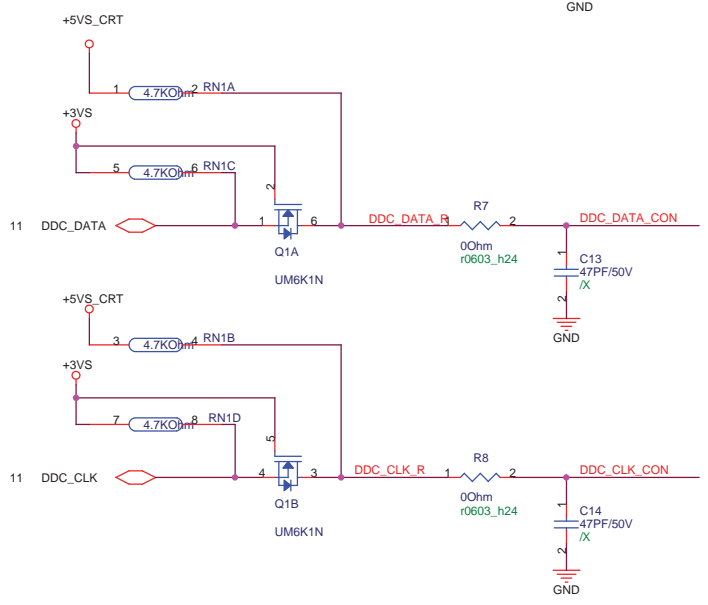
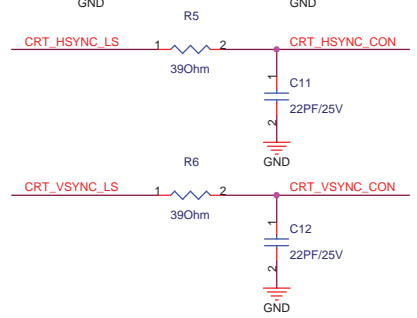
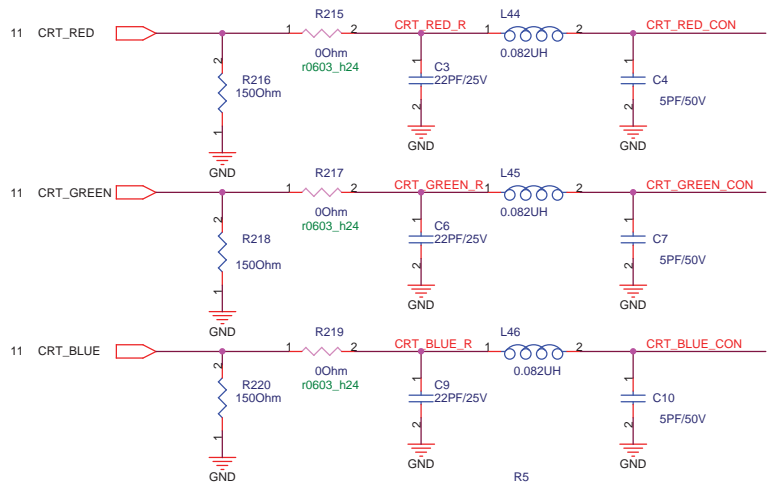

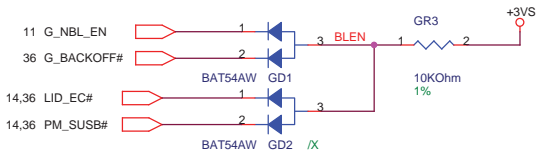
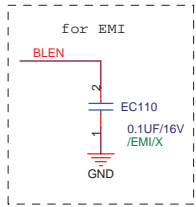
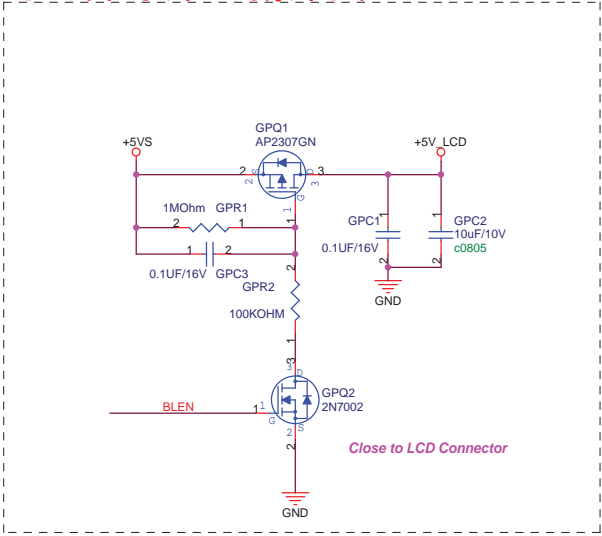
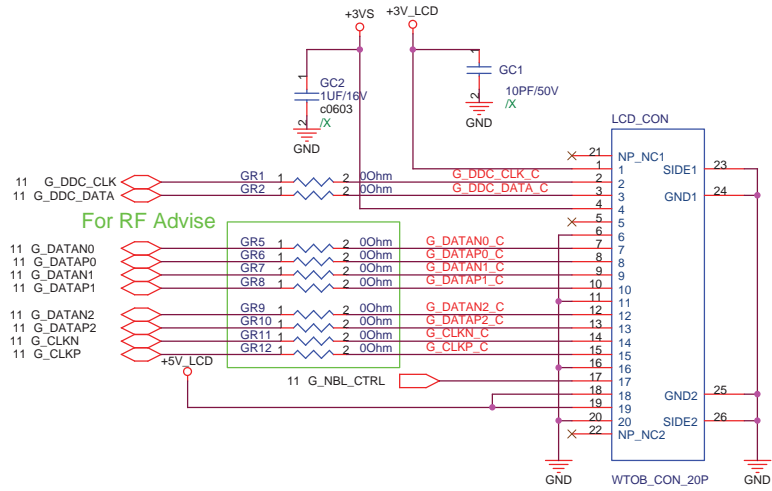

G_DDC_CLK_C	GC4	2	1	10PF/50V
G_DDC_DATA_C	GC5	2	1	10PF/50V
G_CLKP_C	GC6	2	1	10PF/50V
G_CLKN_C	GC7	2	1	10PF/50V
G_DATAP2_C	GC8	2	1	10PF/50V
G_DATAN2_C	GC9	2	1	10PF/50V
G_DATAP1_C	GC10	2	1	10PF/50V
G_DATAN1_C	GC11	2	1	10PF/50V
G_DATAP0_C	GC12	2	1	10PF/50V
G_DATAN0_C	GC13	2	1	10PF/50V

For RF Advise(Close to LCD_CON)

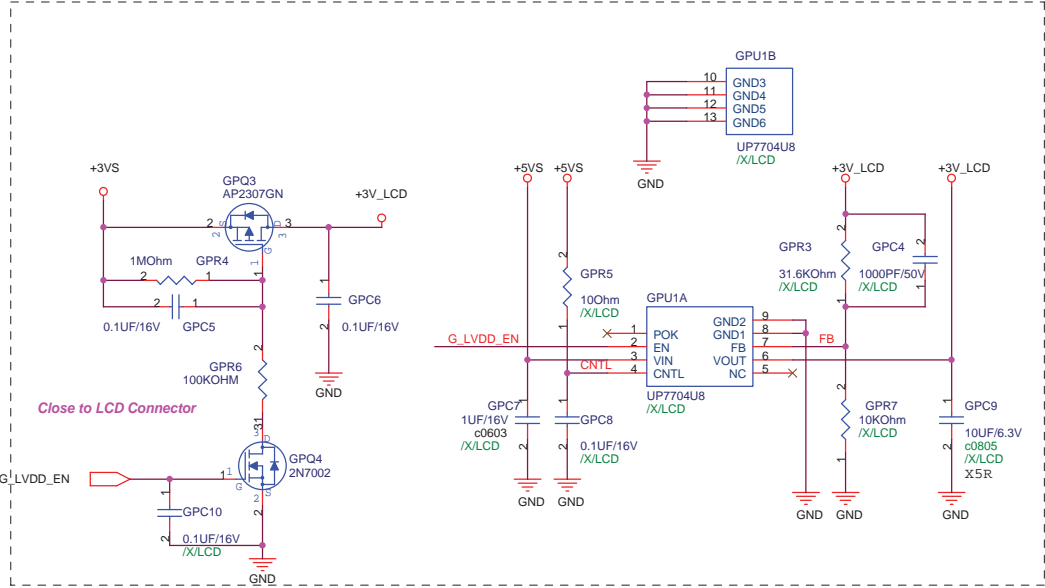
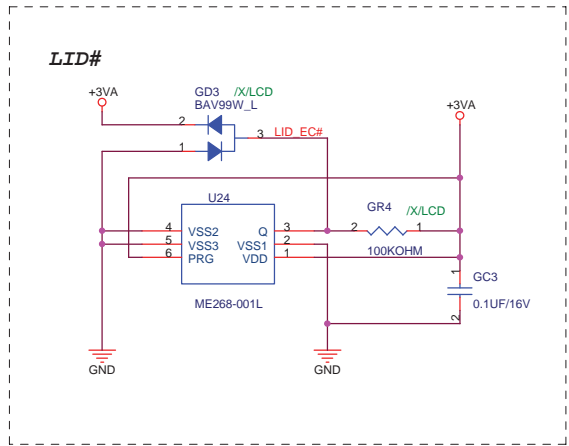

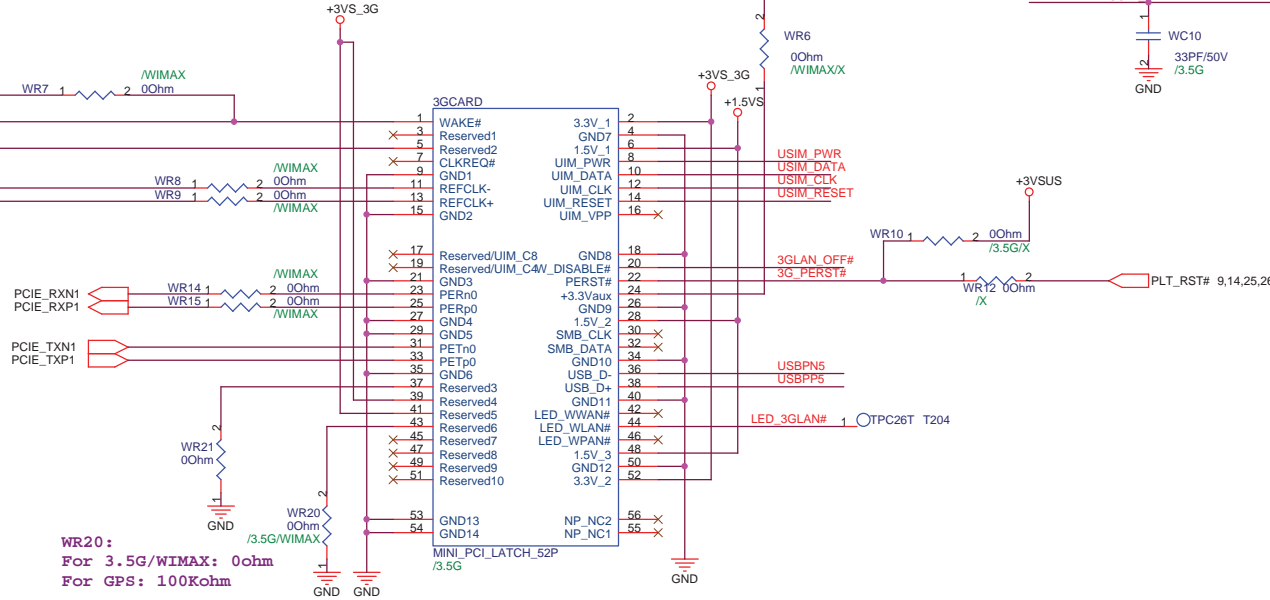
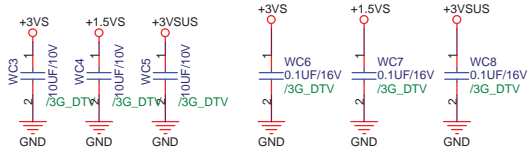
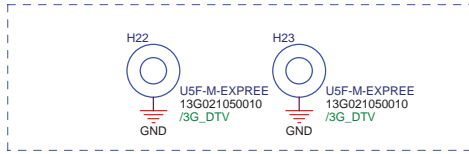
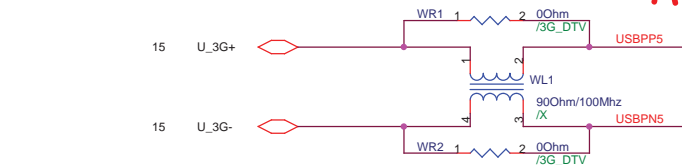

WR20:
For 3.5G/WIMAX: 0ohm
For GPS: 100Kohm

3GCARD use 12G03010052L

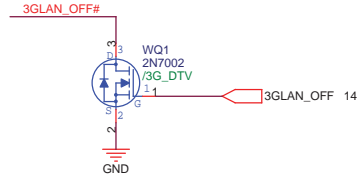
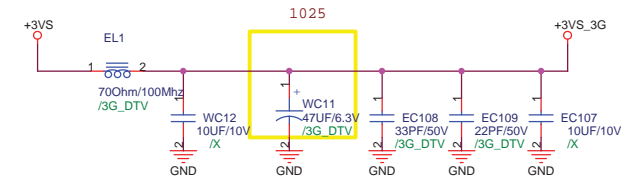
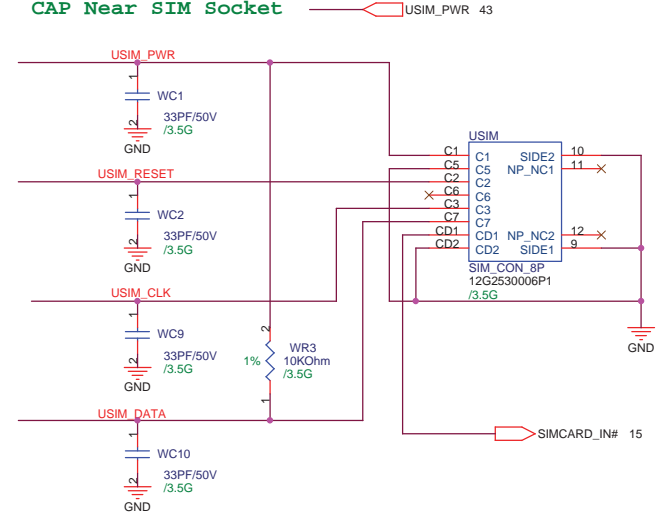

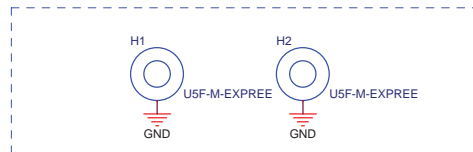
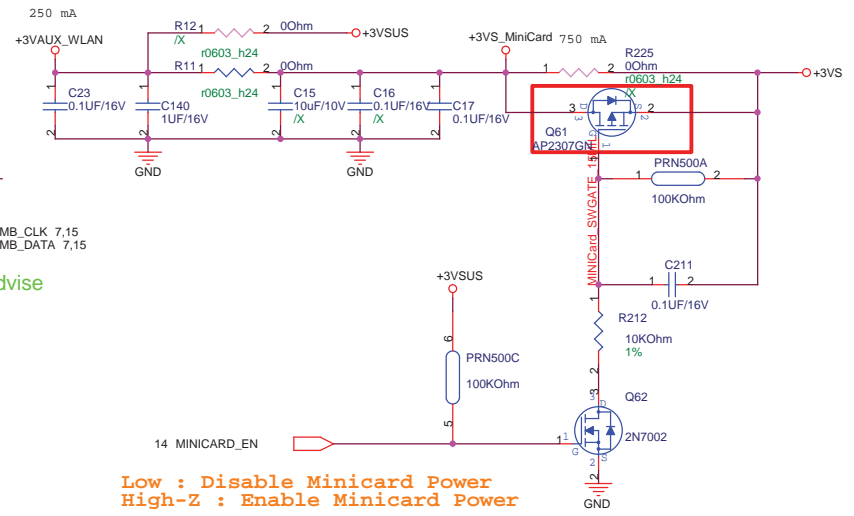
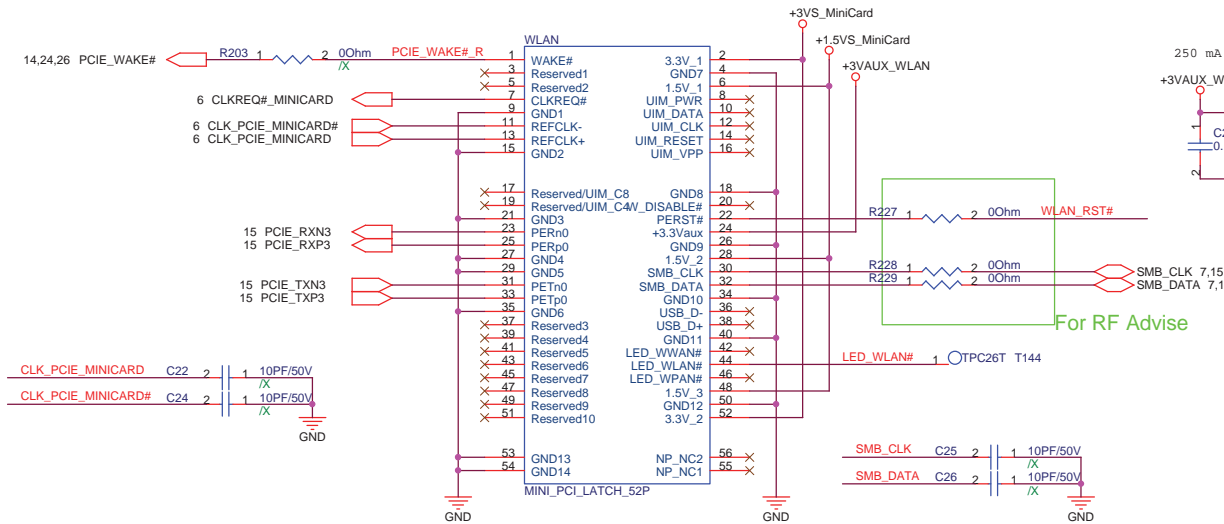
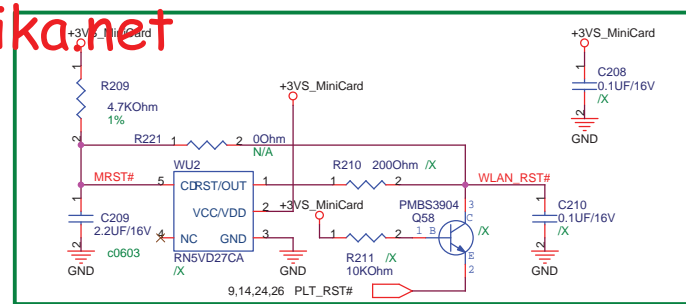

MINI CARD NUT(1.6mm) *2

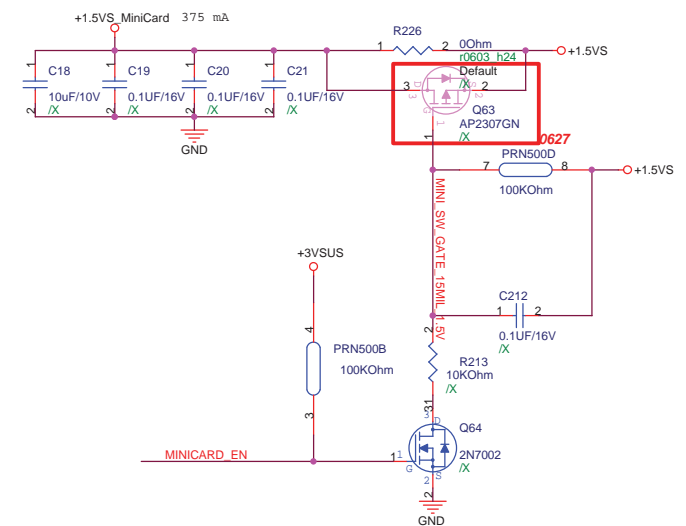
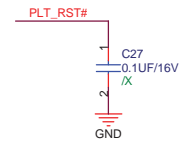

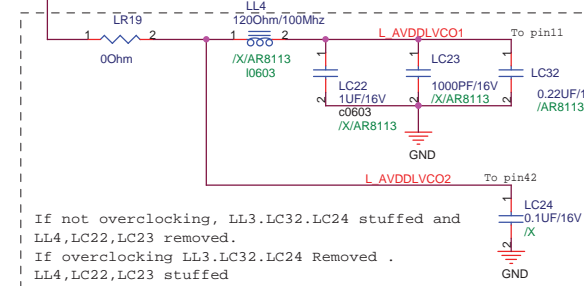
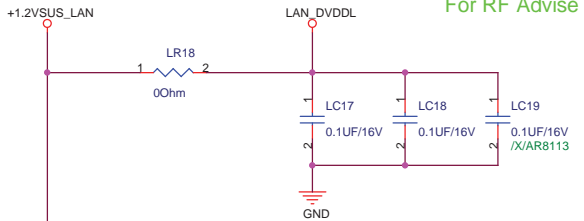
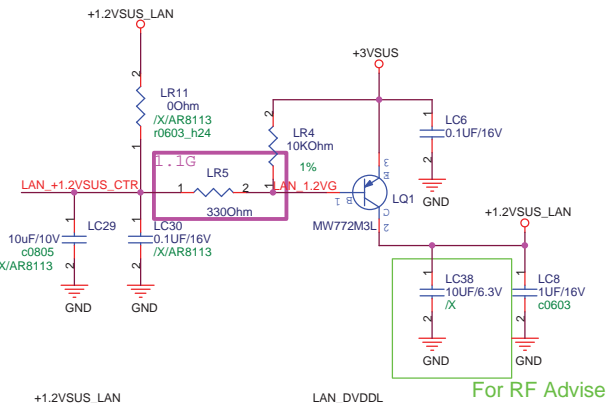
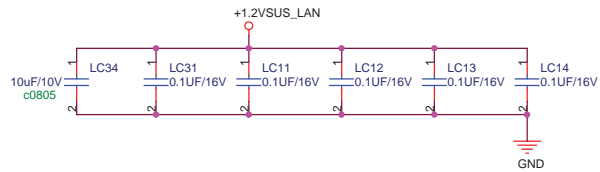
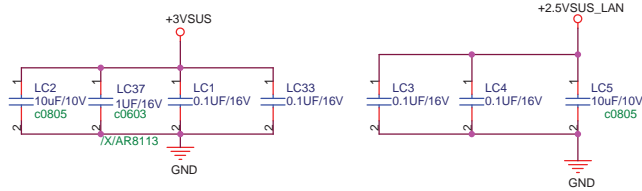

If not overclocking, LL3.LC32.LC24 stuffed and LL4,LC22,LC23 removed.
 IF overclocking LL3.LC32.LC24 Removed .
 LL4,LC22,LC23 stuffed

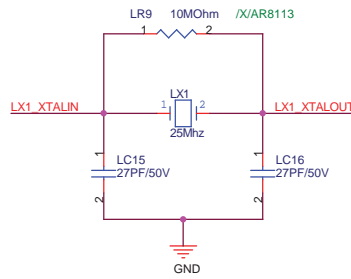

AR8113 internal integrated 1.8V(PIN1) and 2.5V(PIN6) regulator!

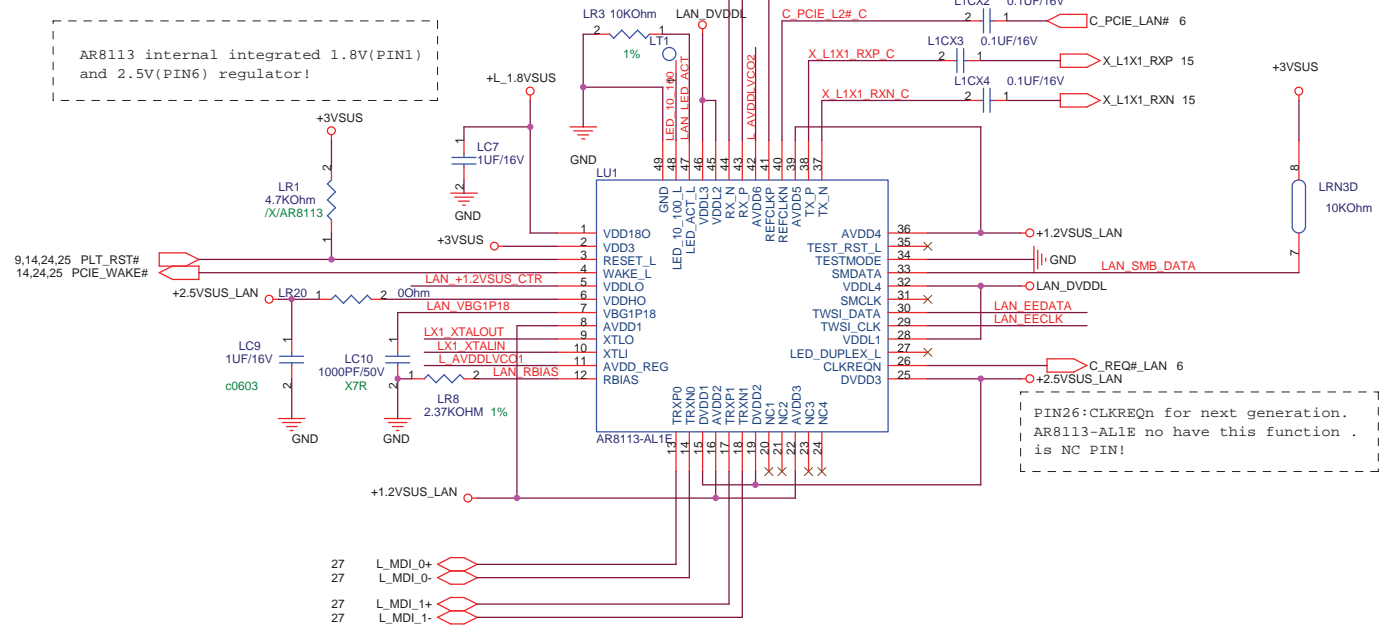

PIN26: CLKREQn for next generation. AR8113-AL1E no have this function . is NC PIN!

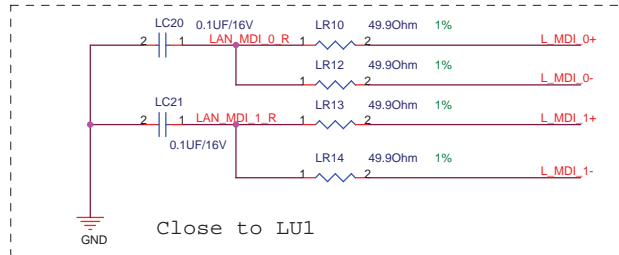

Close to LU1

DELETE MODEM

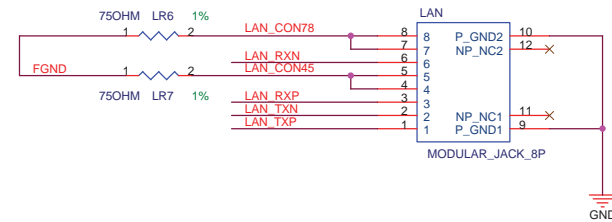
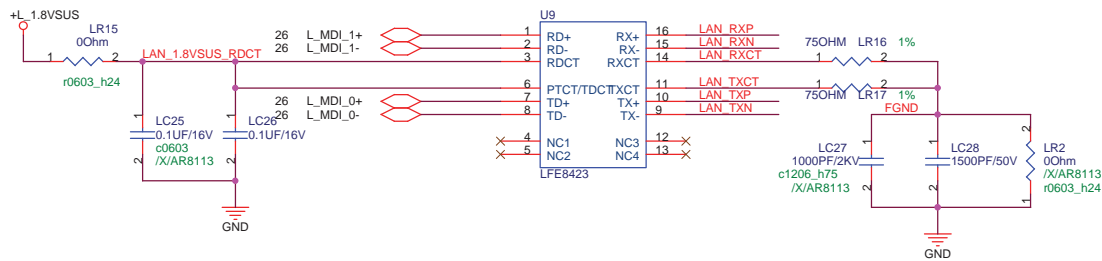

Default Group-A7V8X MX

ASUS		Title : RJ45	
ASUSTek Computer INC.		Engineer: Hauld_Zhou	
Size	Project Name		Rev
A3	900SD_MB		R1.0G
Date:	Monday, November 10, 2008	Sheet	27 of 51

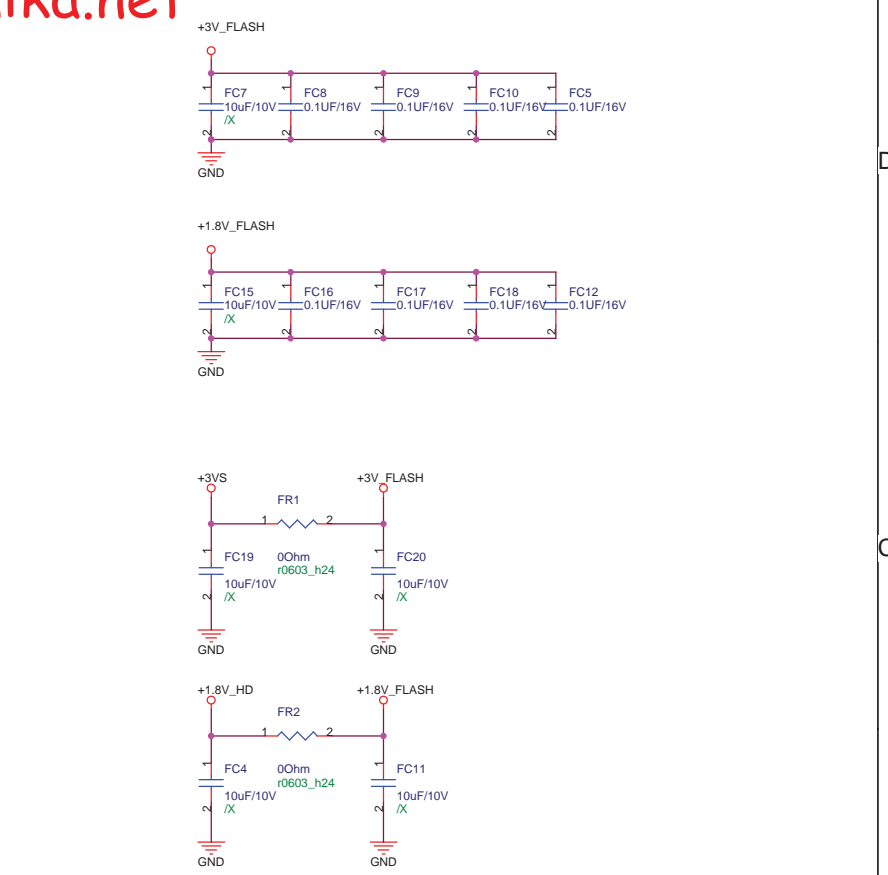
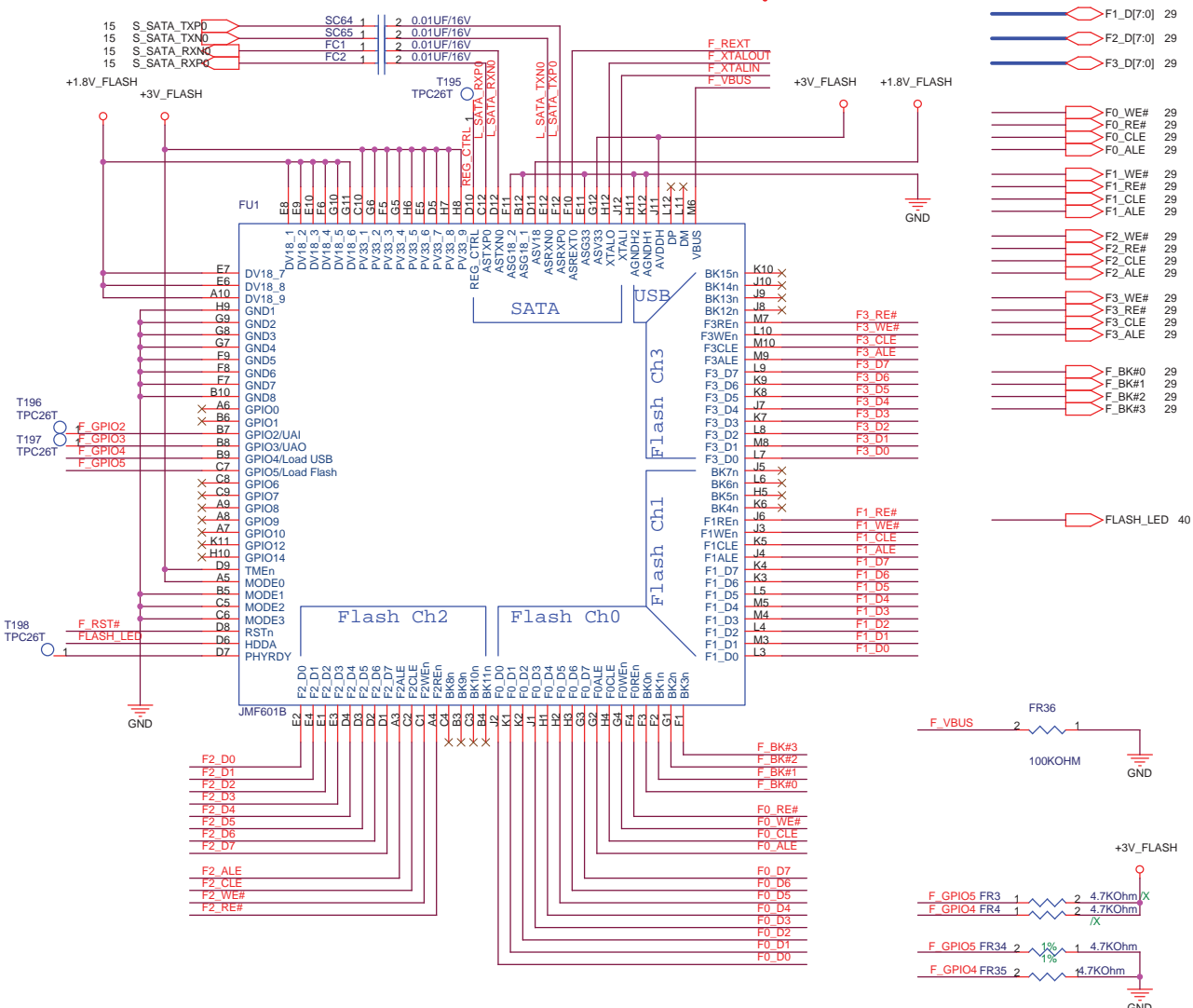

GPIO5	GPIO4	MODE
L	L	Load F/W code from Flash, SATA I mode
H	H	Load F/W code from SATA

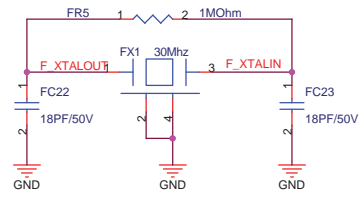
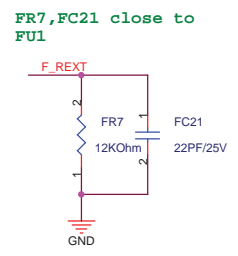
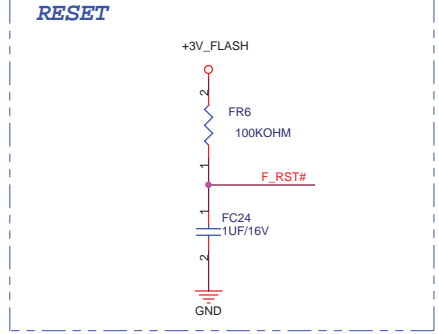

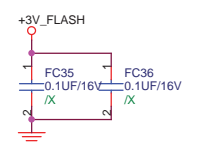
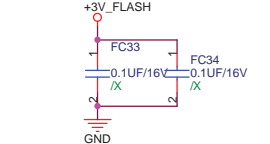
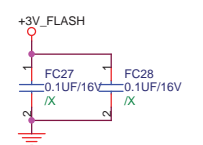
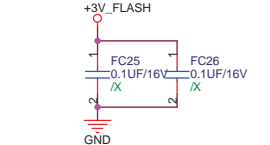
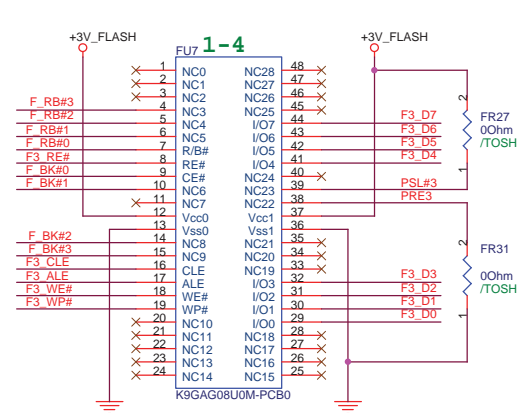
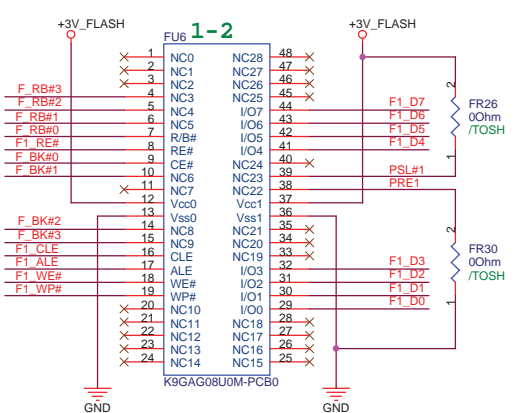
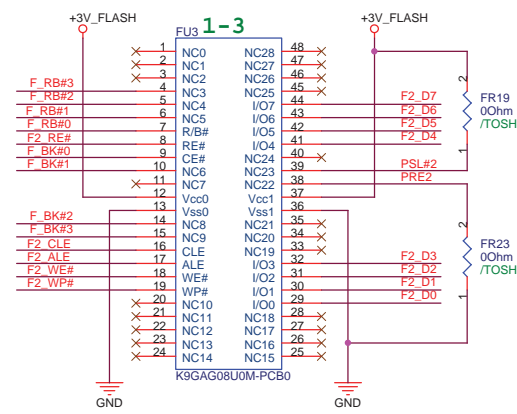
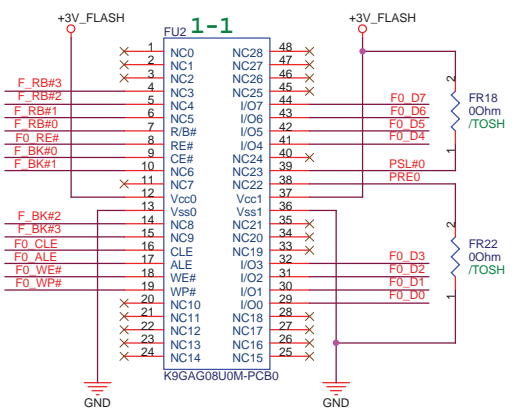
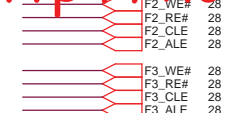
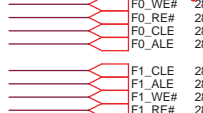

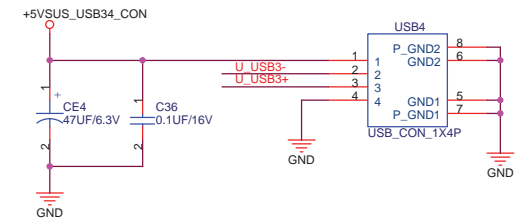
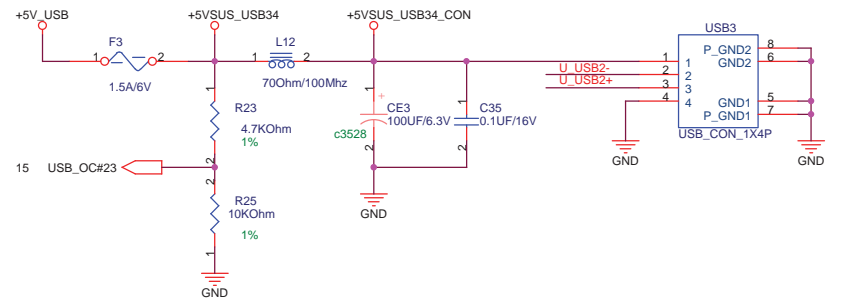
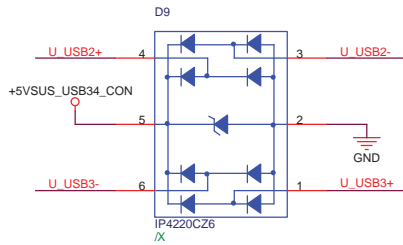
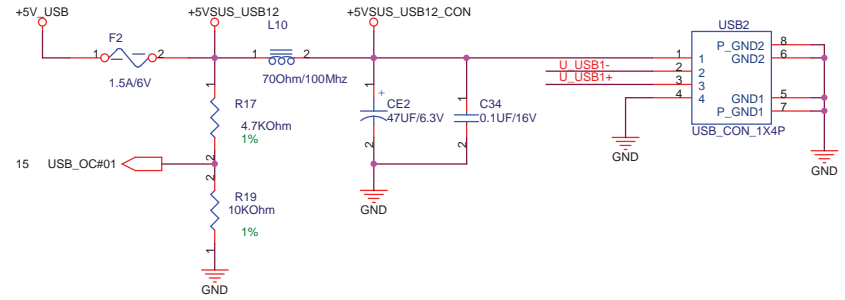
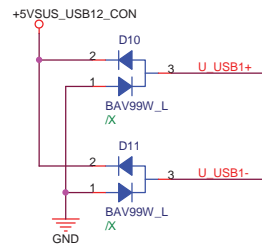
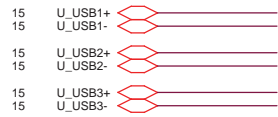

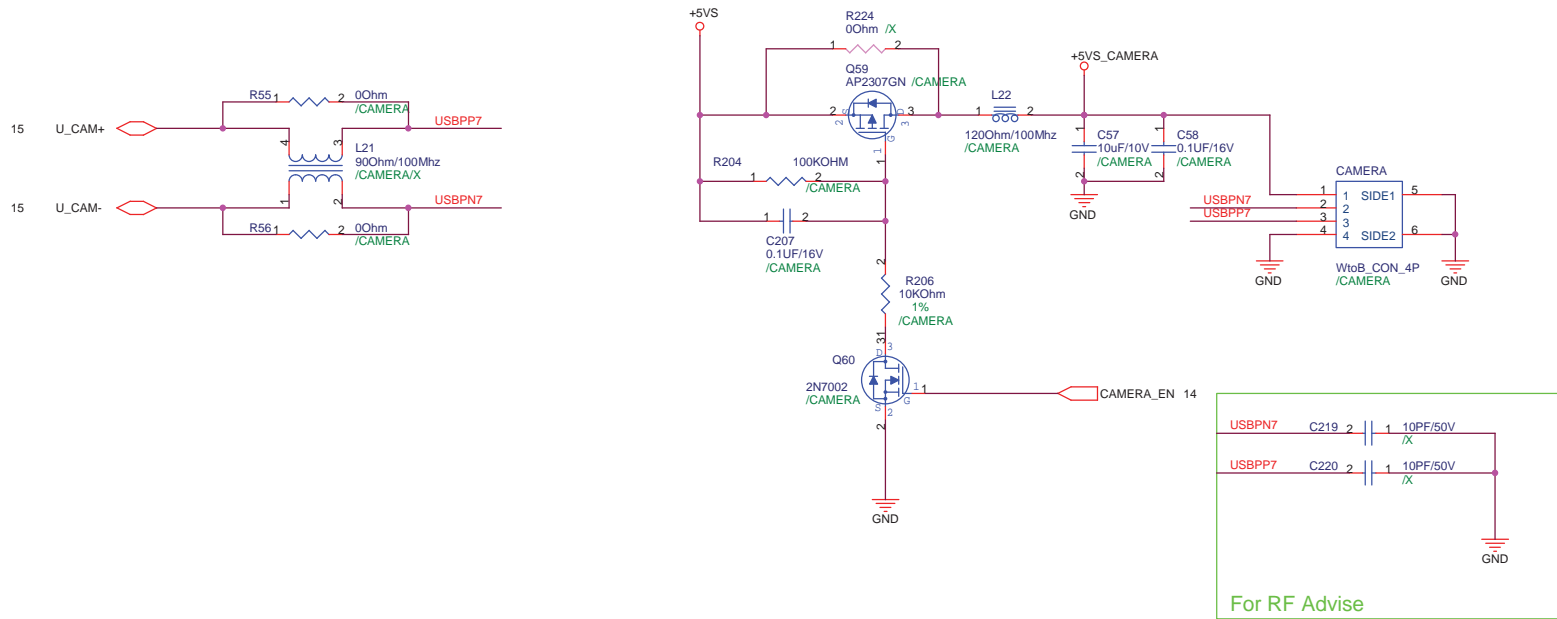

Default Group-A7V8X MX

ASUS		Title : Camera Conn	
ASUSTek Computer INC.		Engineer: <i>Kell_Huang</i>	
Size	Project Name		Rev
A3	900SD_MB		R1.0G
Date: Monday, November 10, 2008		Sheet	32 of 51

$V_{out} = 0.8 * (1 + (49.9K / 10.2K))$

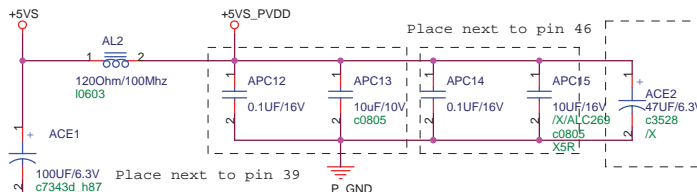
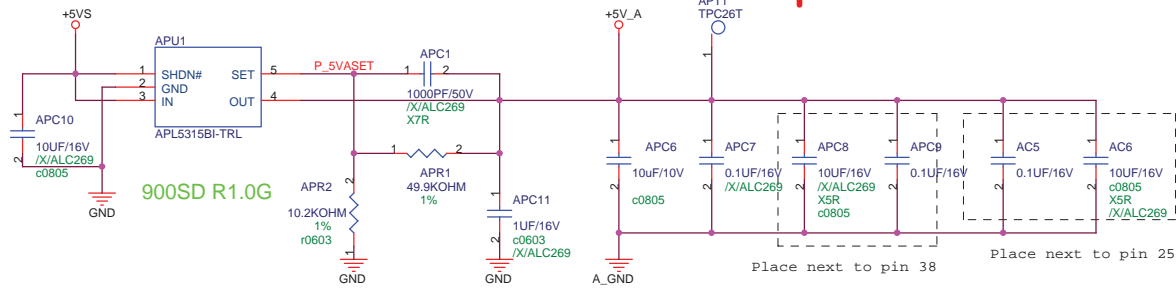

Surges of PVDD >7V duration 0.1ms when class D amplifier is working may damage the amplifier, 10uF tantalum capacitors are required at PVDD1 and PVDD2 to upress the surge.

A_PD#	speaker AMP.
H	power down
L	power up

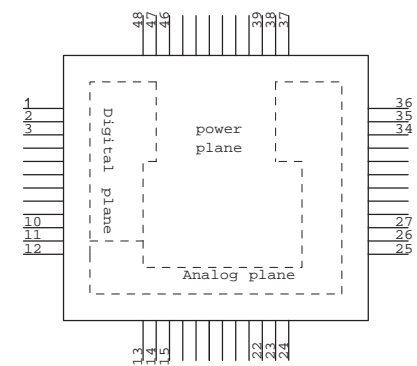
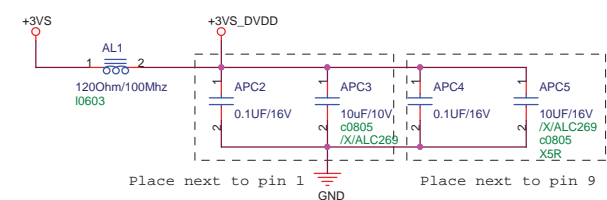
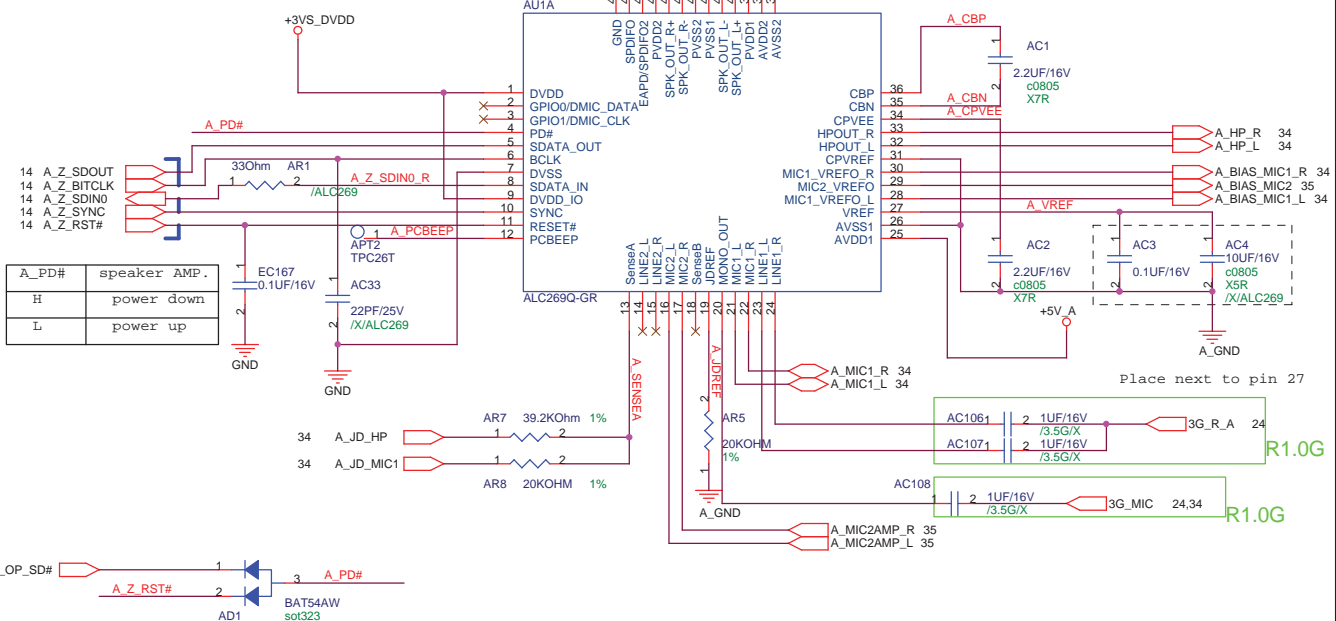

Default Group-A7V8X MX

ASUS Title : ALC269-1

ASUSTek Computer INC. Engineer: Jeff_Li

Size	Project Name	Rev
A3	900SD_MB	R1.0G

Date: Monday, November 10, 2008 Sheet 33 of 51

Internal MIC

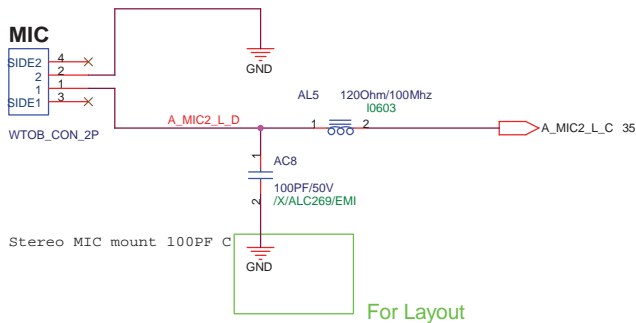

SPEAKER

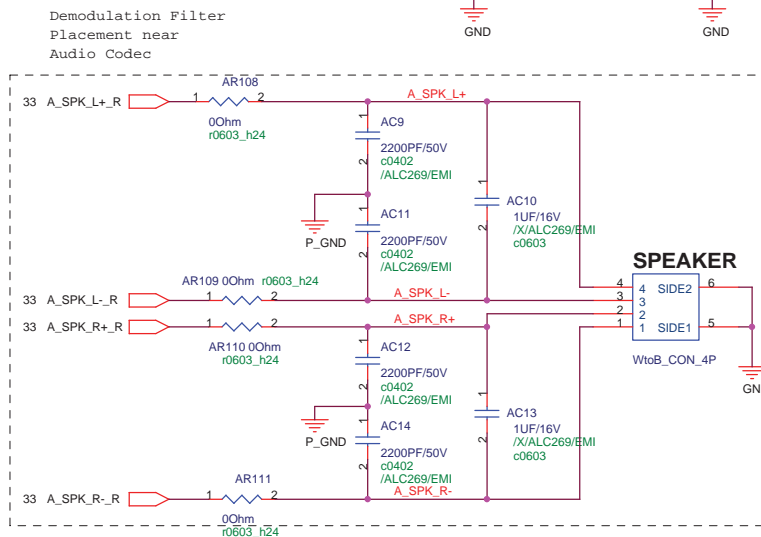

HP

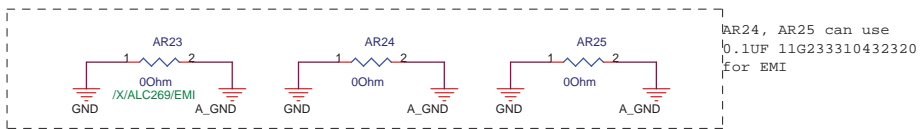
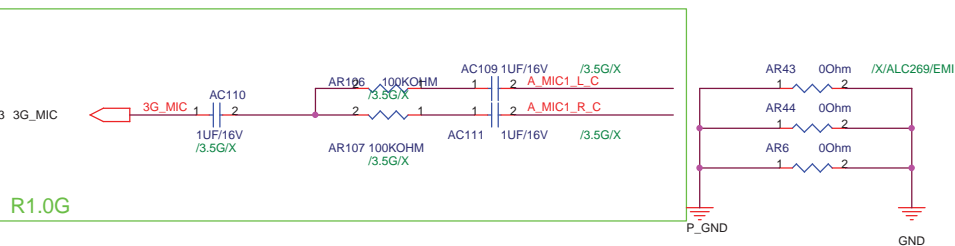
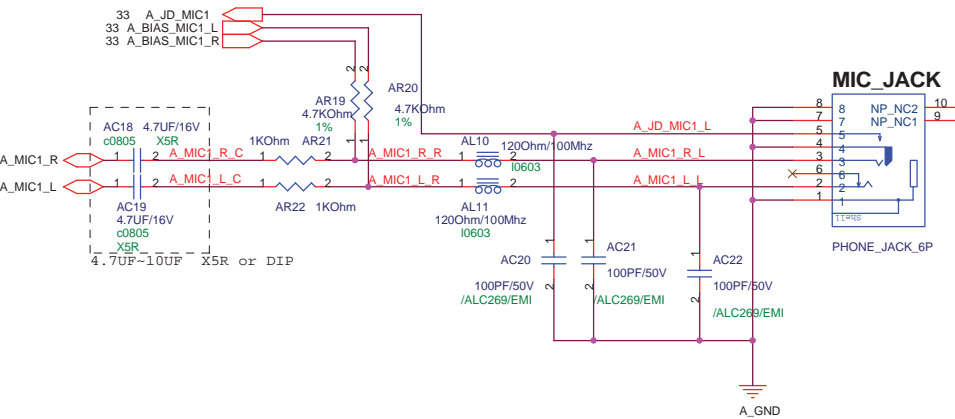
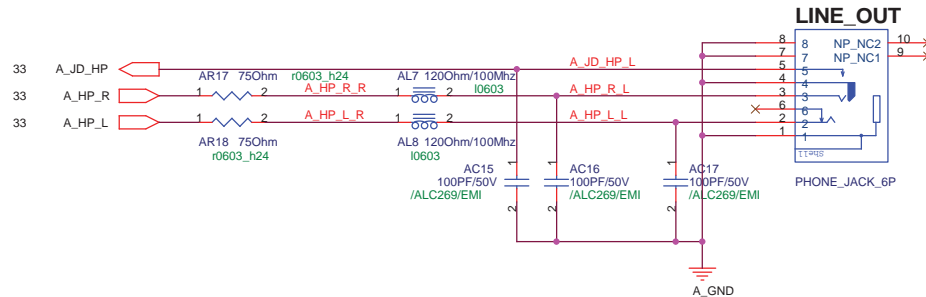

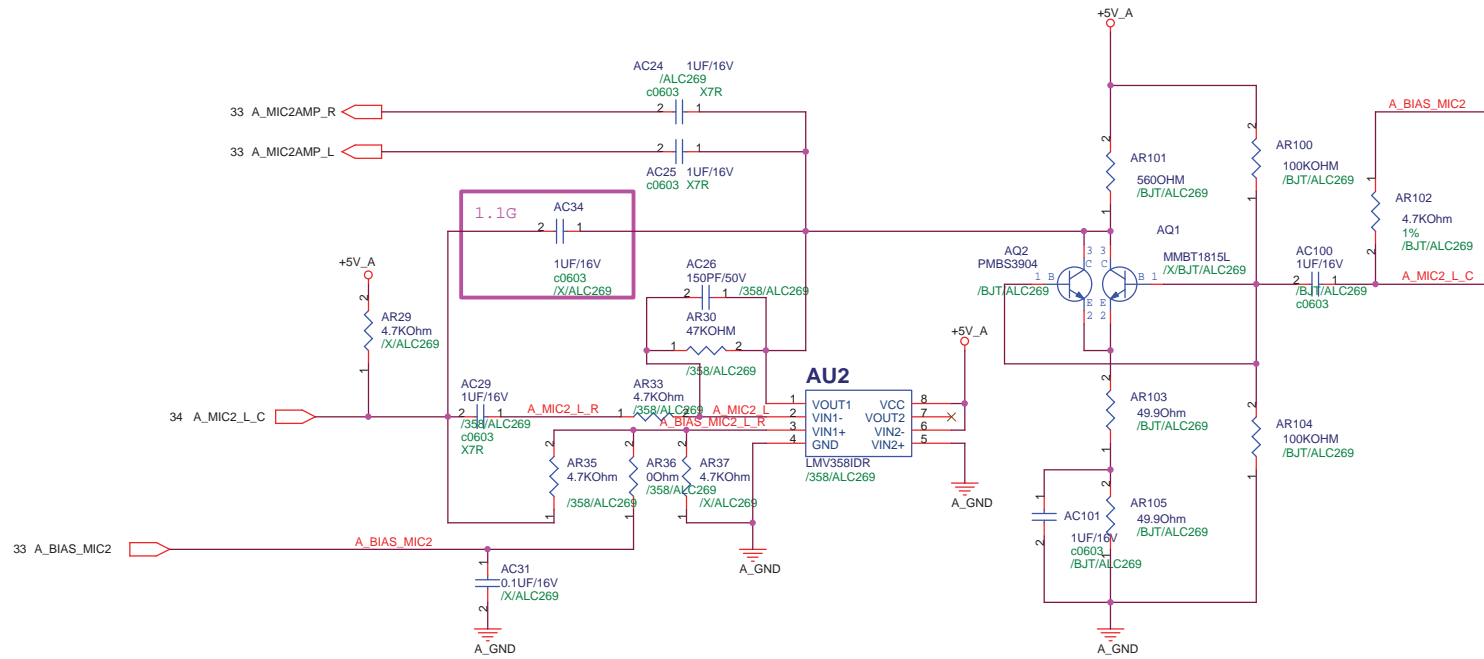

Default Group-A7V8X MX

ASUS		Title : ALC269-3(MIC AMP)	
ASUSTek Computer INC.		Engineer: Jeff_Li	
Size	Project Name		Rev
A3	900SD_MB		R1.0G
Date: Monday, November 10, 2008	Sheet	35	of 51

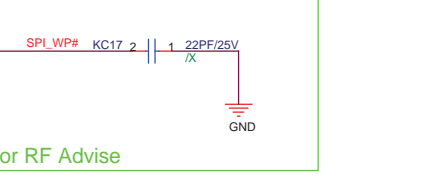
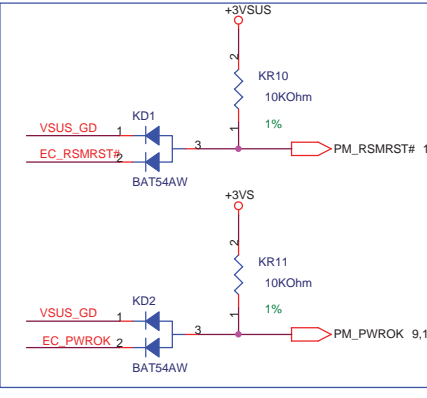
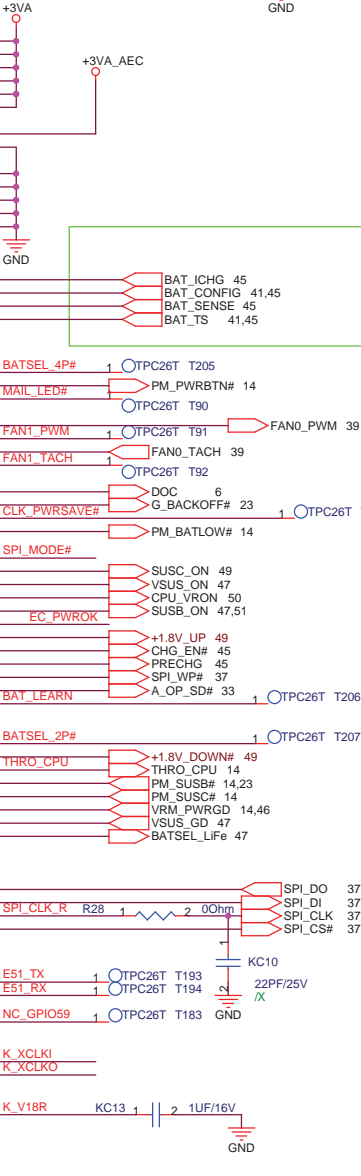
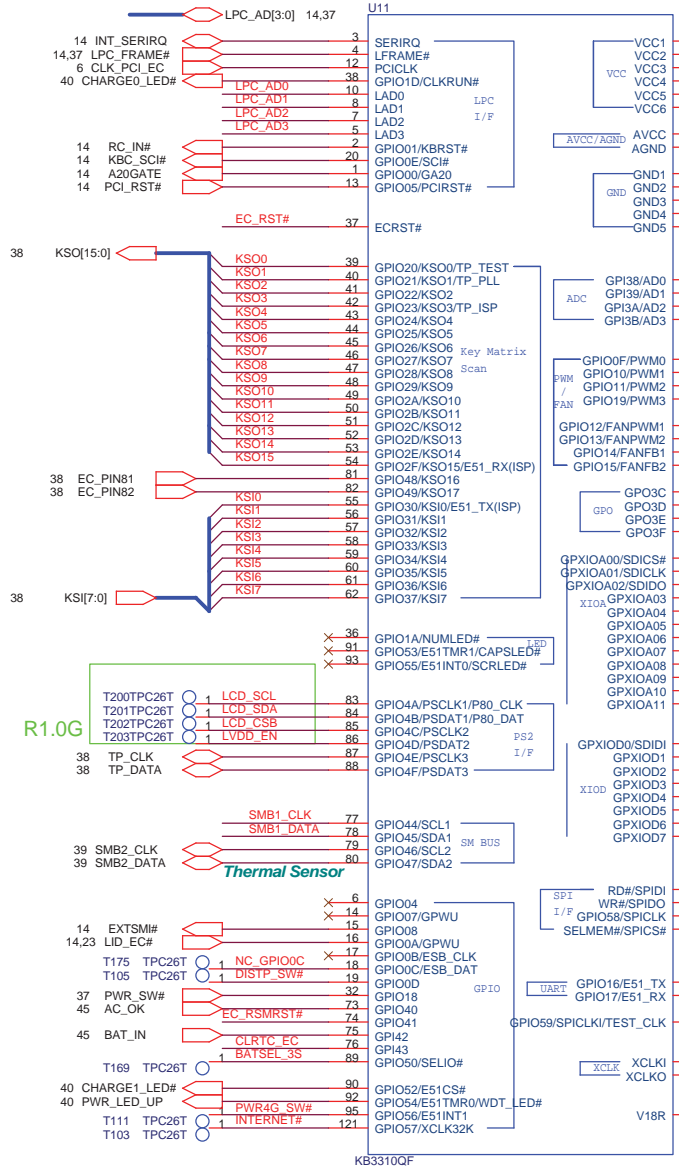
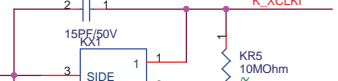
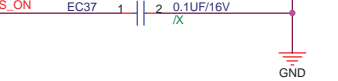
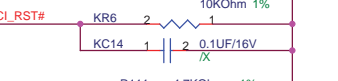
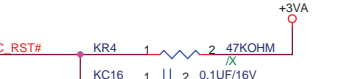
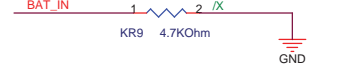
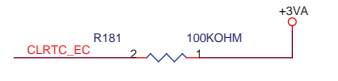
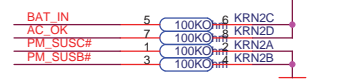
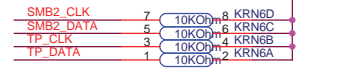
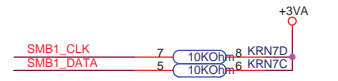
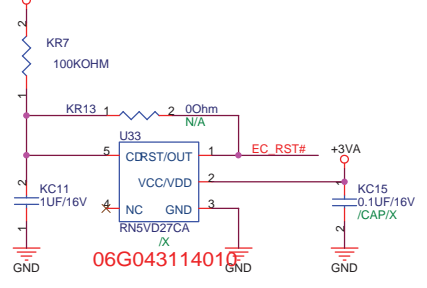
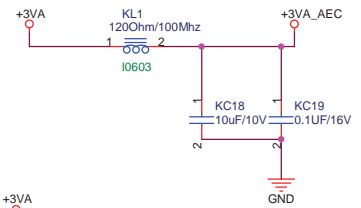
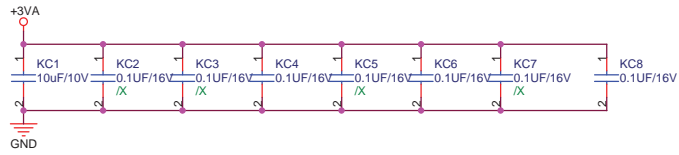

ASUS logo and project information: Title: EC_ENE KB3310, Engineer: Kell Huang, Project Name: 900SD_MB, Date: Monday, November 10, 2008, Sheet 36 of 51.

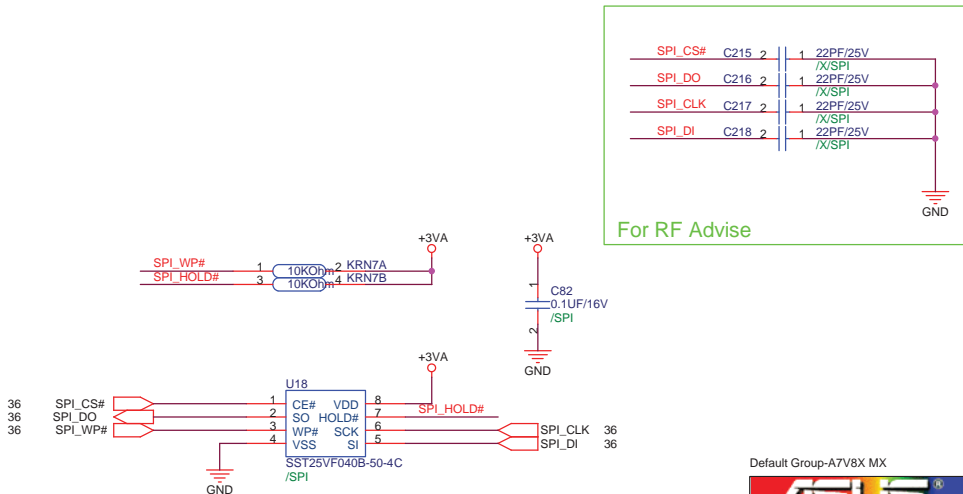
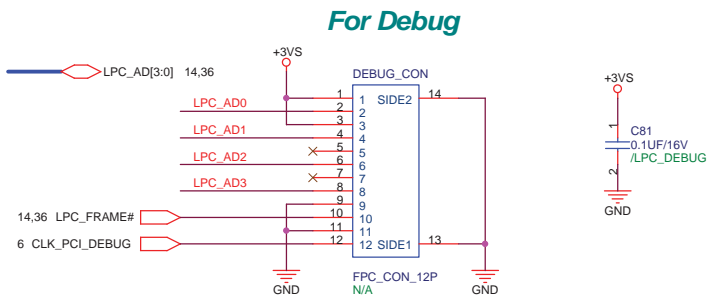
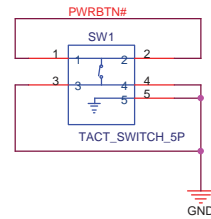
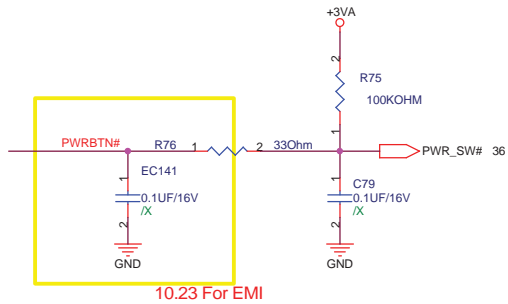

For Touch-Pad

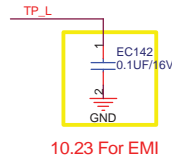
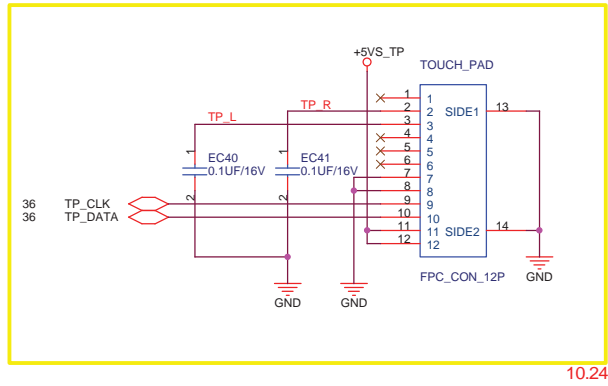
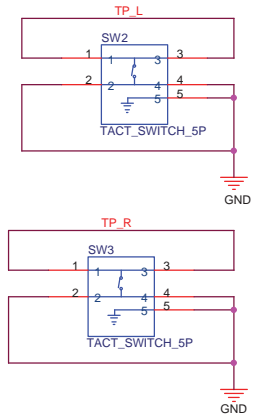

For Keyboard

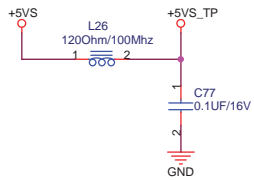

- KSO15 1 TPC26T T188
- KSI0 1 TPC26T T189
- KSO3 1 TPC26T T190

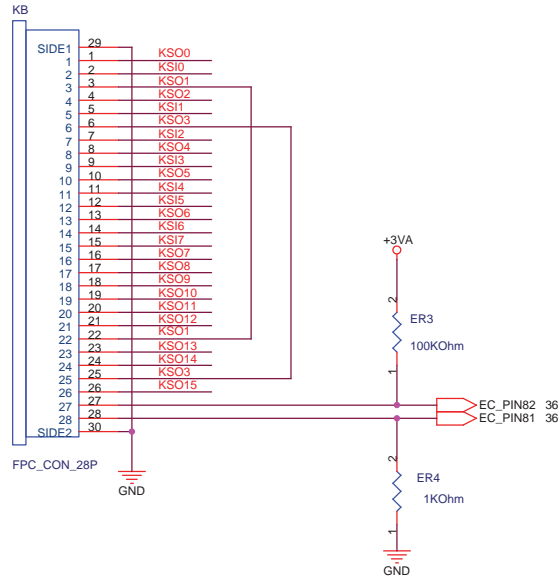

- KSO[15:0] 36
- KSI[7:0] 36

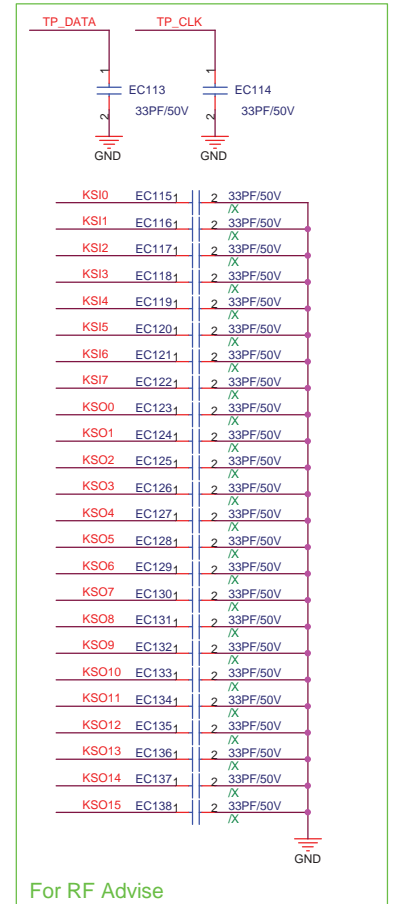
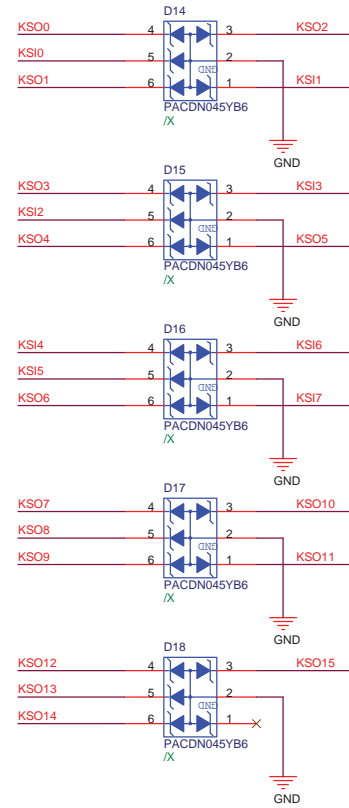

For RF Advise

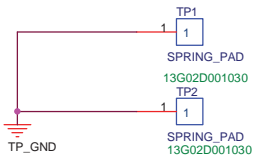
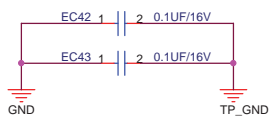

Default Group-A7V8X MX

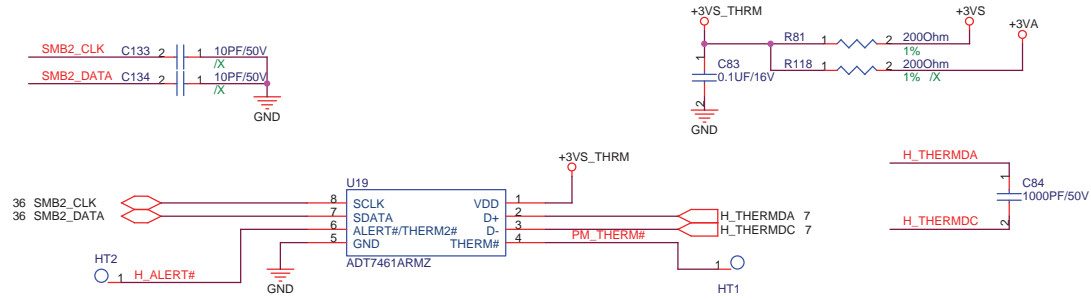

U19 use 06G023048021

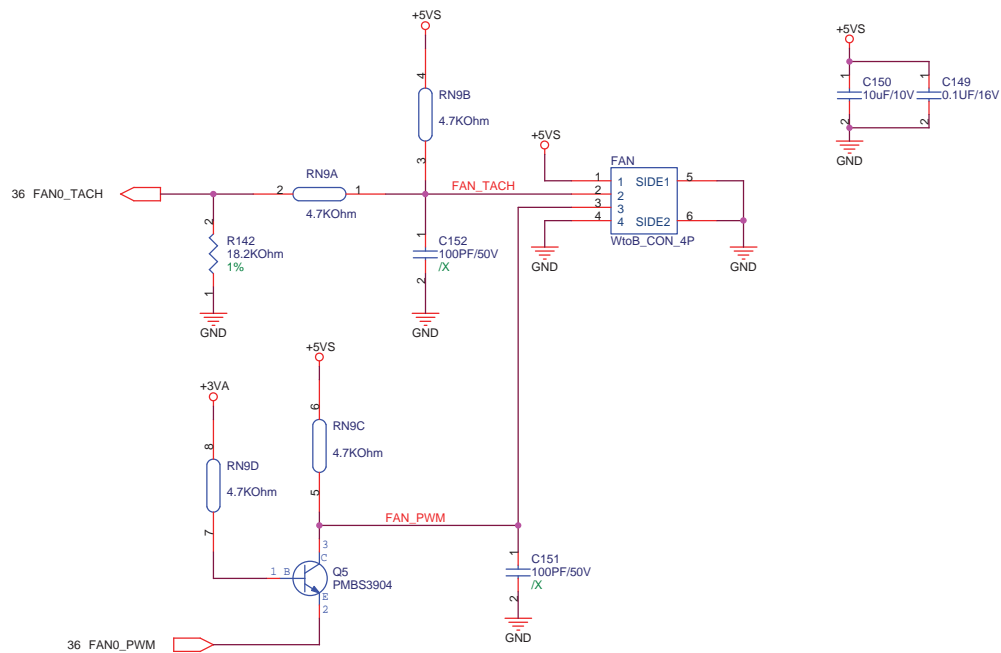

Default Group-A7V8X MX

ASUS		Title : Thermal Sensor_FAN	
ASUSTek Computer INC.		Engineer: Keli_Huang	
Size	Project Name		Rev
A3	900SD_MB		R1.0G
Date:	Monday, November 10, 2008	Sheet	39 of 51

for POWER LED

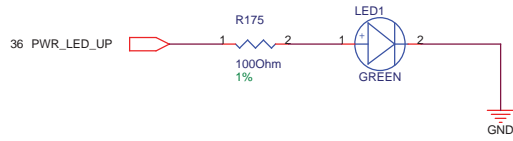

for FLASH LED

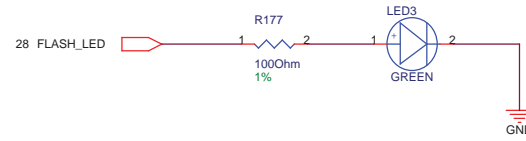

for WLAN LED

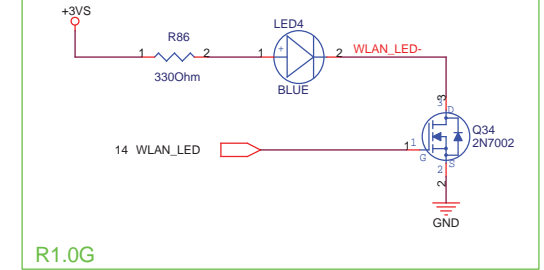

R1.0G

for CHARGE LED

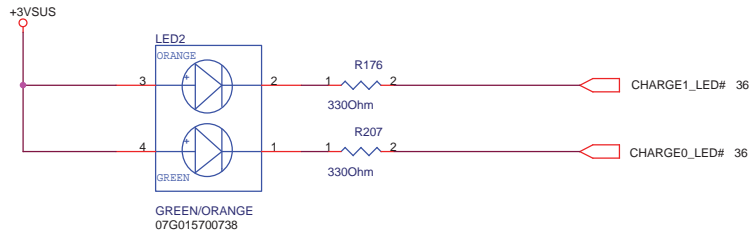

Default Group-A7V8X MX

ASUS		Title : LED	
ASUSTek Computer INC.		Engineer: <i>Hauld_Zhou</i>	
Size	Project Name		Rev
A3	900SD_MB		R1.0G
Date: Monday, November 10, 2008	Sheet	40	of 51

DC IN

<http://hobi-elektronika.net>

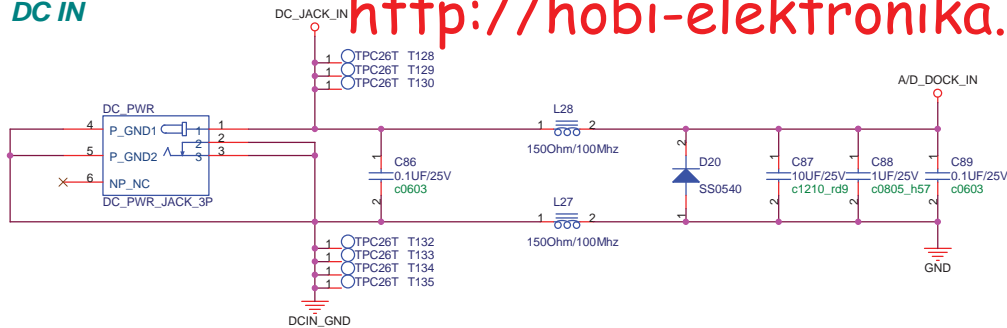

BAT IN

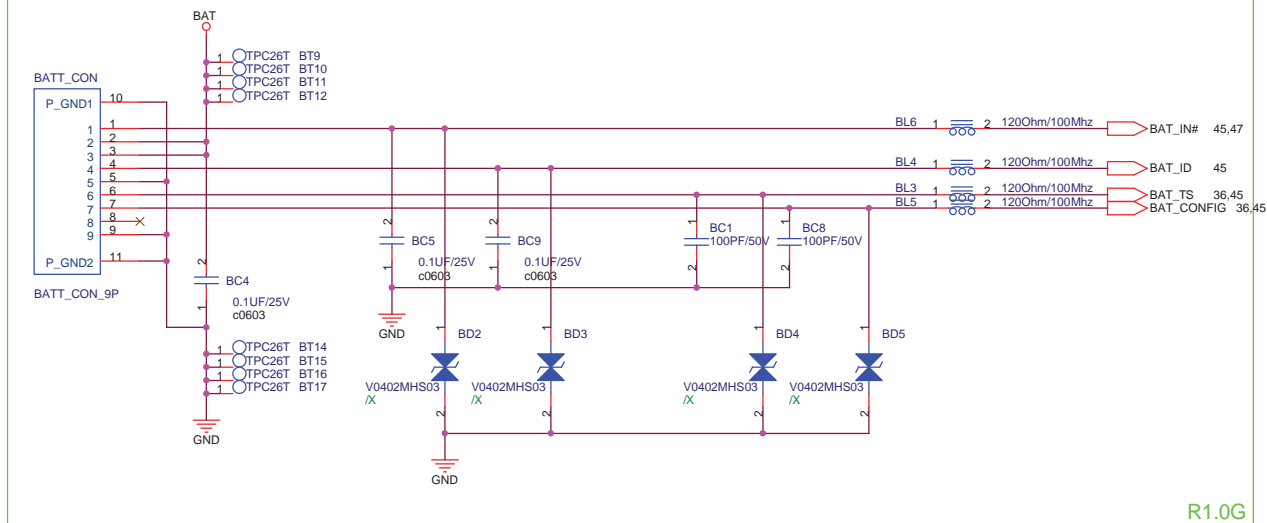

Default Group-A7V8X MX

		Title : PWR Jack	
ASUSTek Computer INC.		Engineer: Kell_Huang	
Size A3	Project Name 900SD_MB	Rev R1.0G	
Date: Monday, November 10, 2008		Sheet 41 of 51	

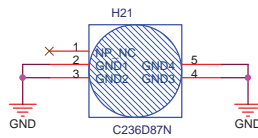
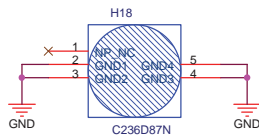
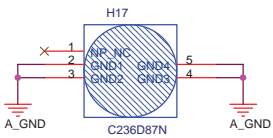
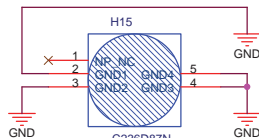
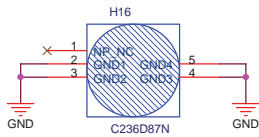
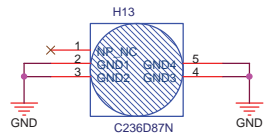
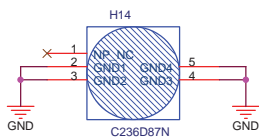
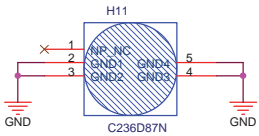
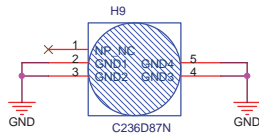
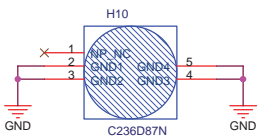
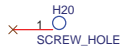
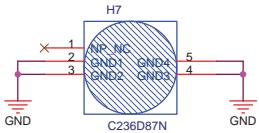
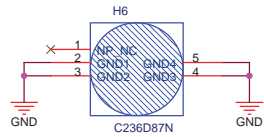
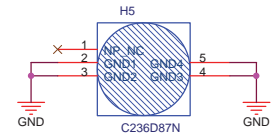

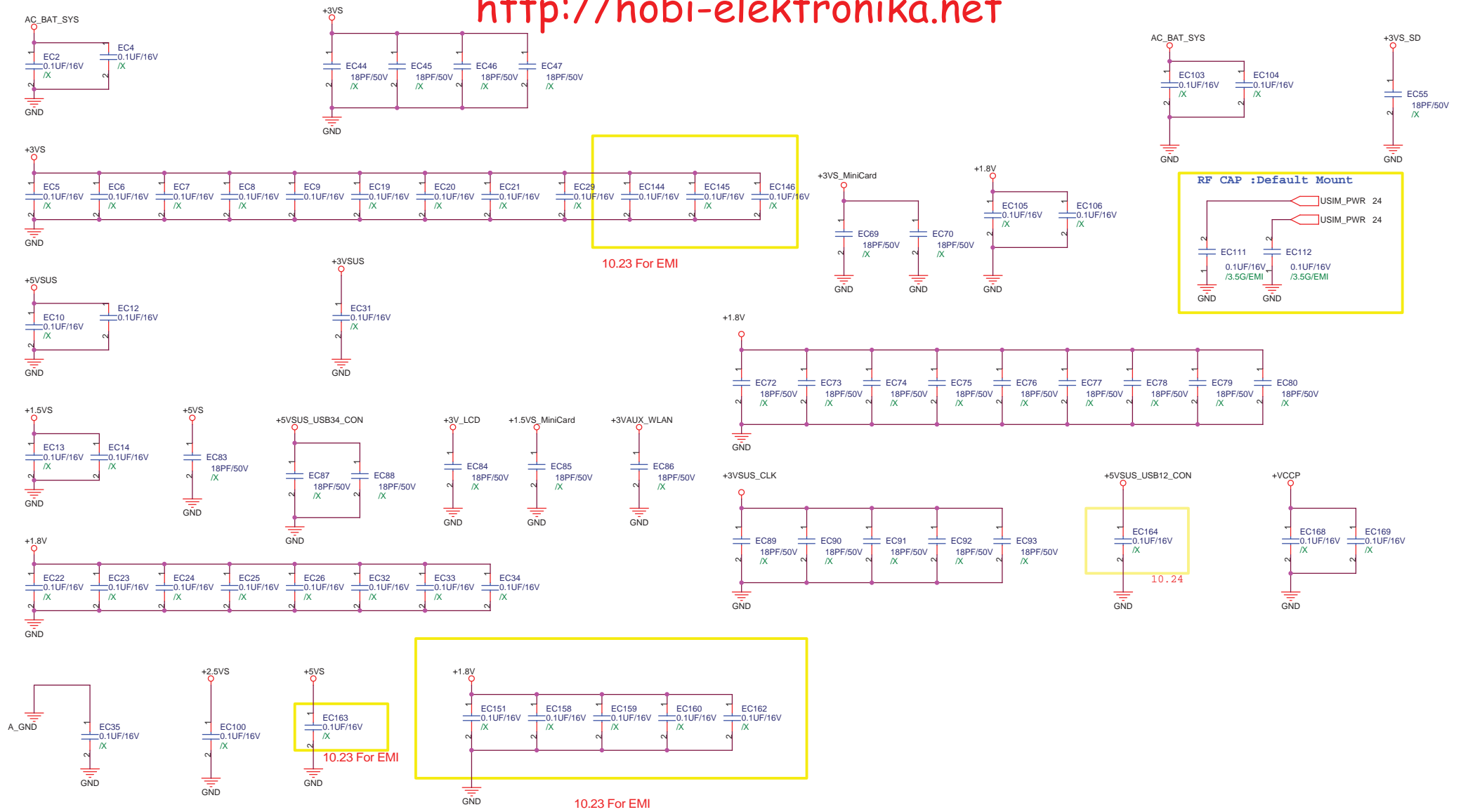

POWER CHARGER

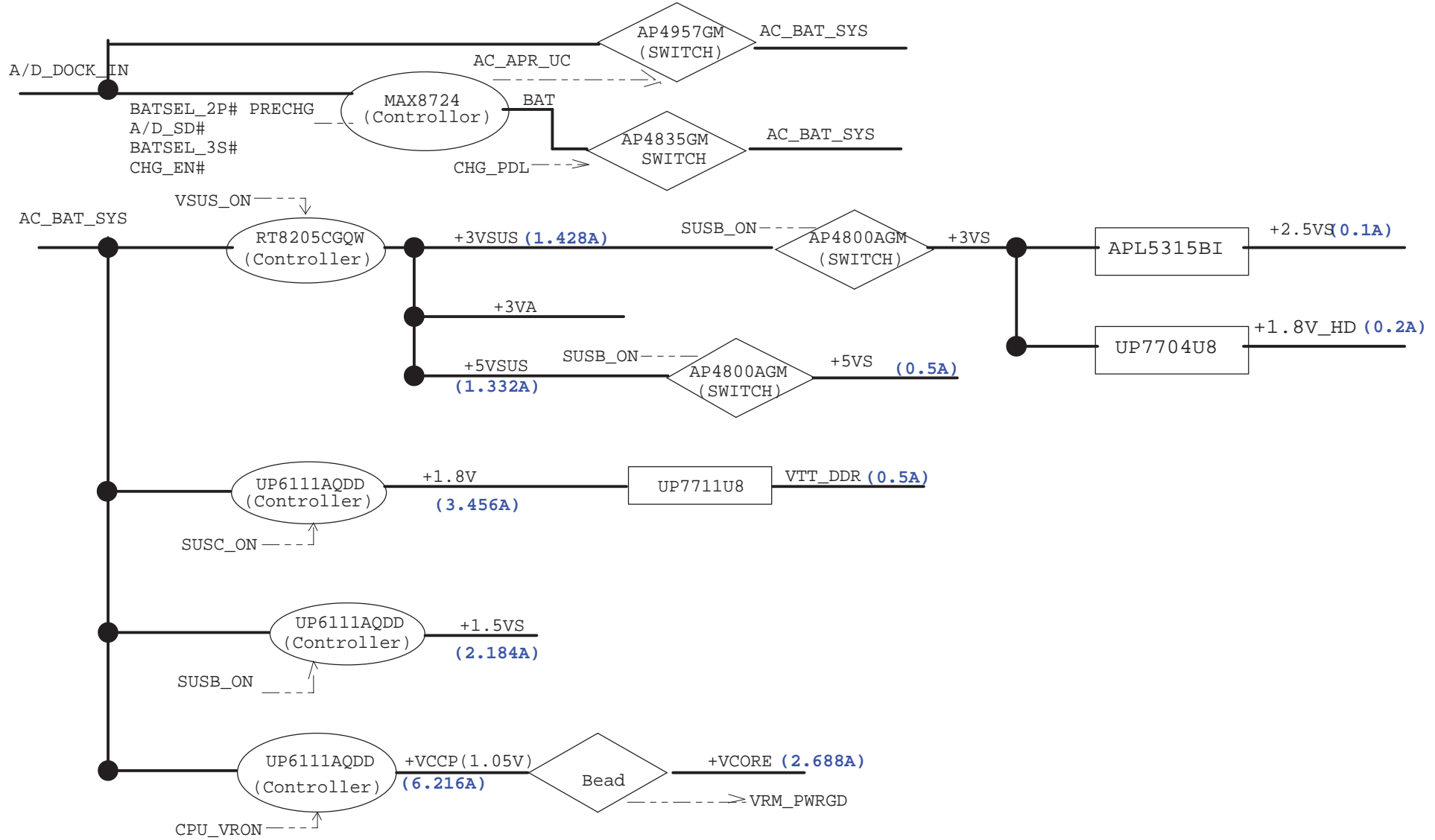

+Vcore / 7A

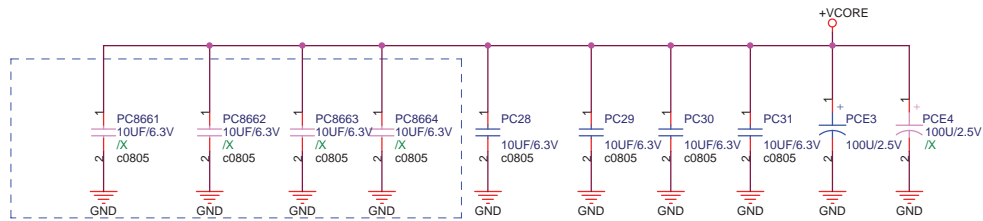

2008-10-15

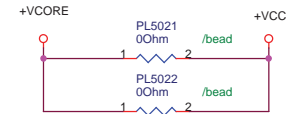
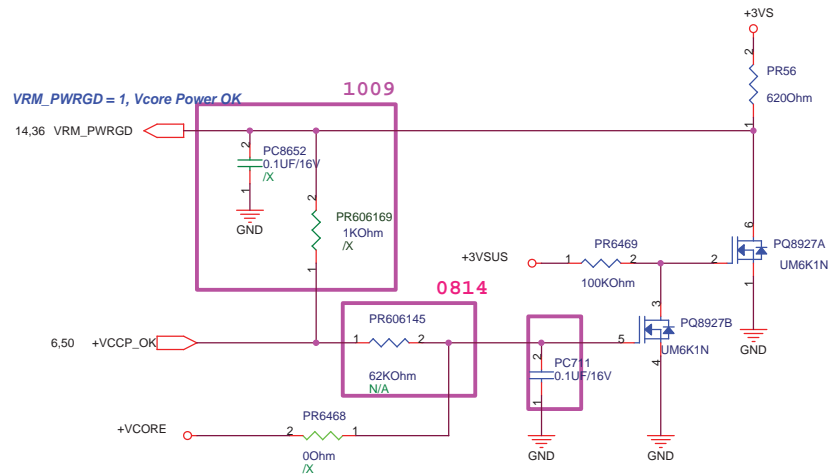

Default Group-A7V8X MX

ASUS		Title : Vcore	
ASUSTek Computer INC.		Engineer: Joy_Zhou	
Size	Project Name	Rev	
A3	900SD_MB	R1.0C	
Date: Monday, November 10, 2008		Sheet	46 of 51

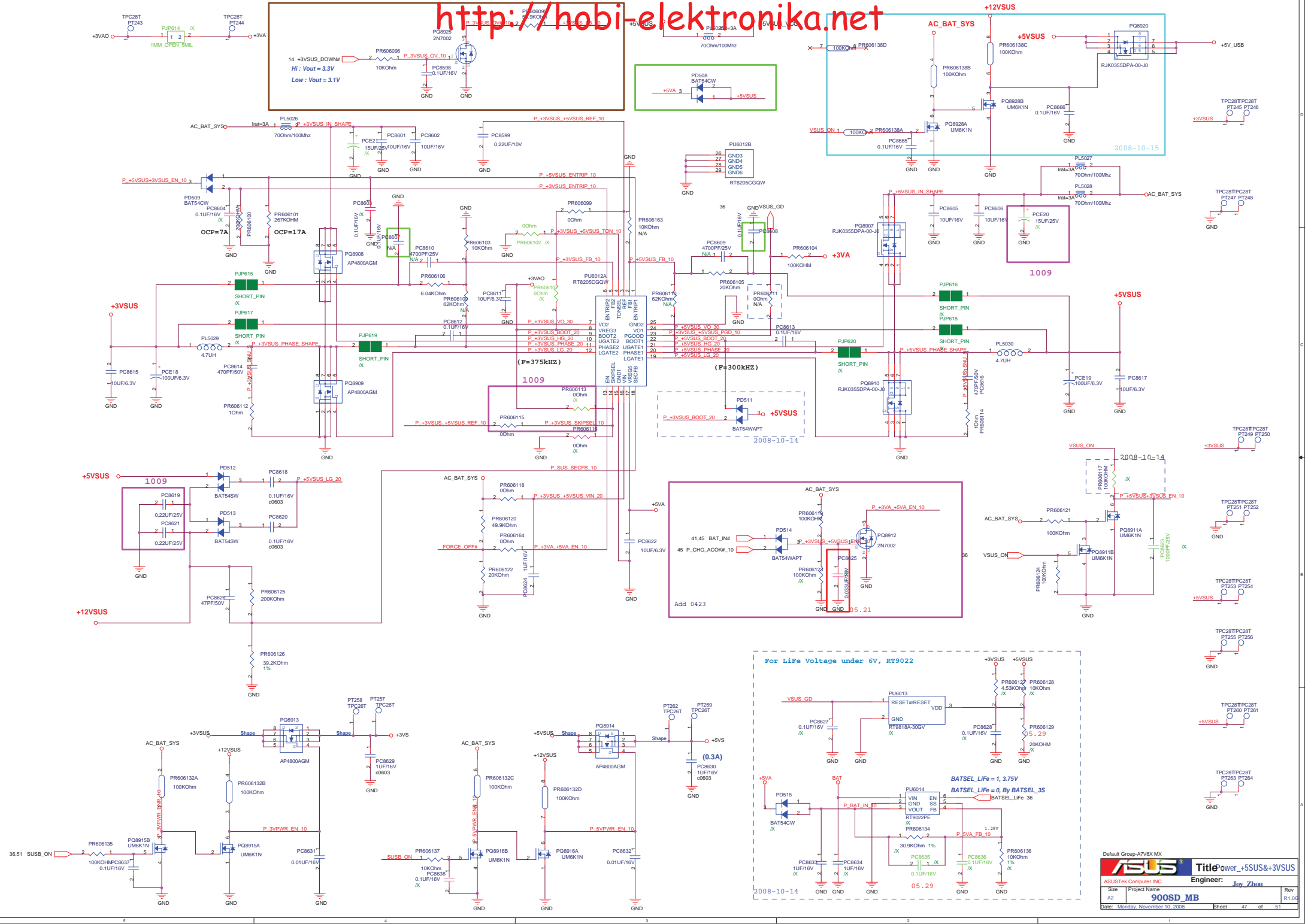

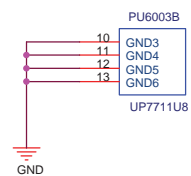
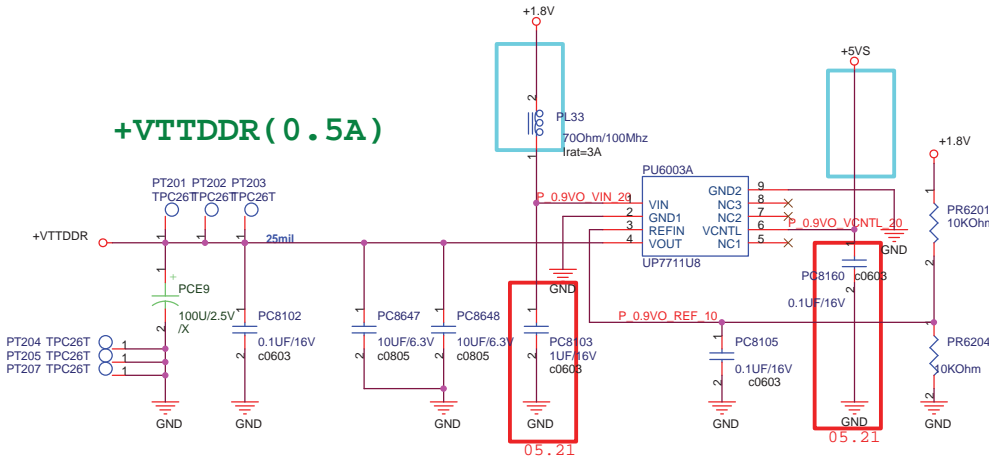
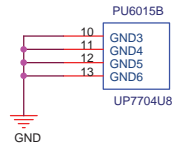
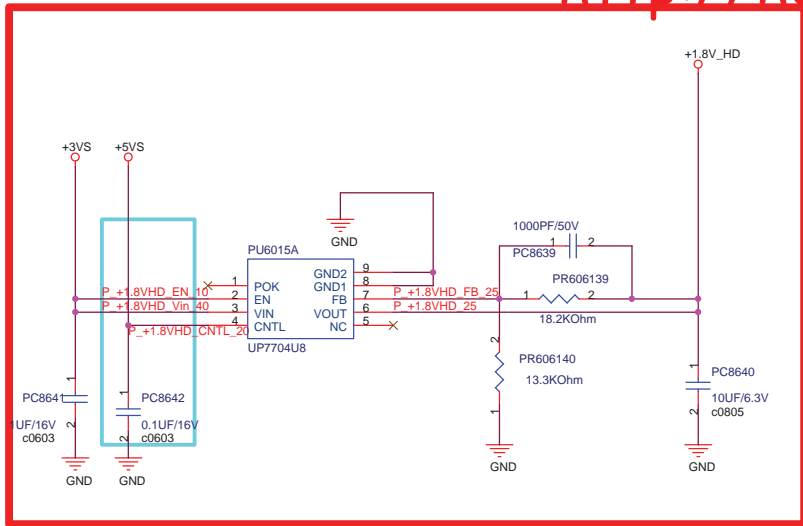

Default Group-A7V8X MX

ASUS		Title : 1.8VHD_VTT_DDR	
ASUSTek Computer INC.		Engineer: <i>Joy_Zhou</i>	
Size	Project Name		Rev
A3	900SD_MB		R1.0C
Date: Monday, November 10, 2008		Sheet	48 of 51

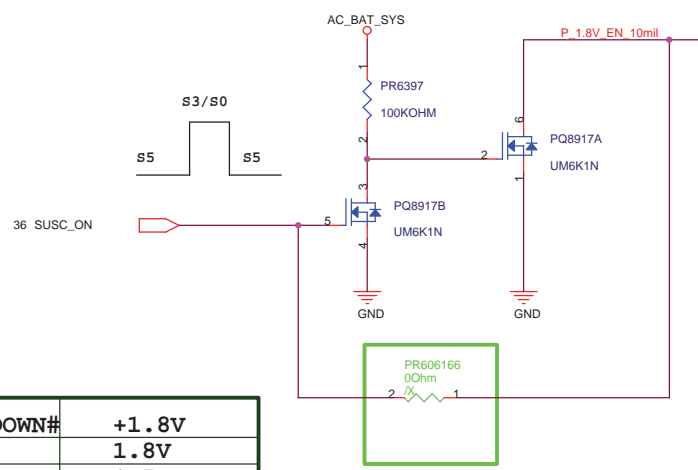
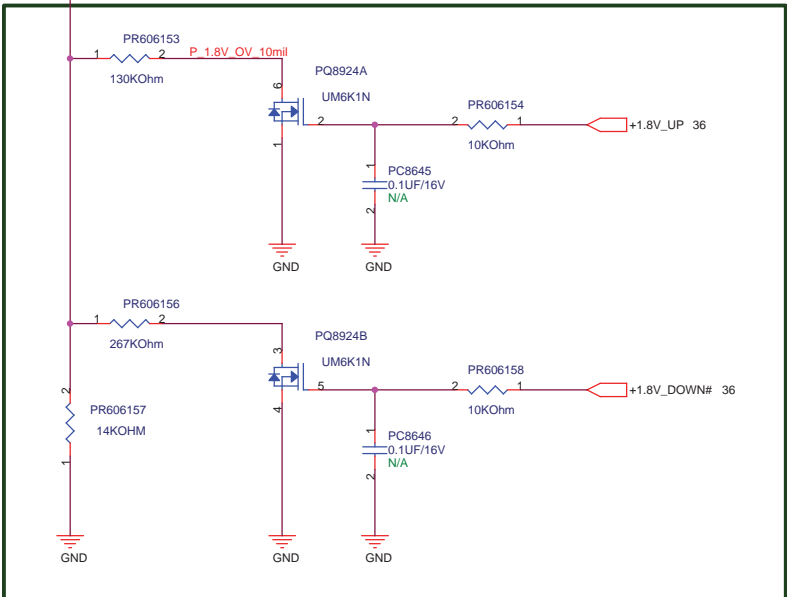
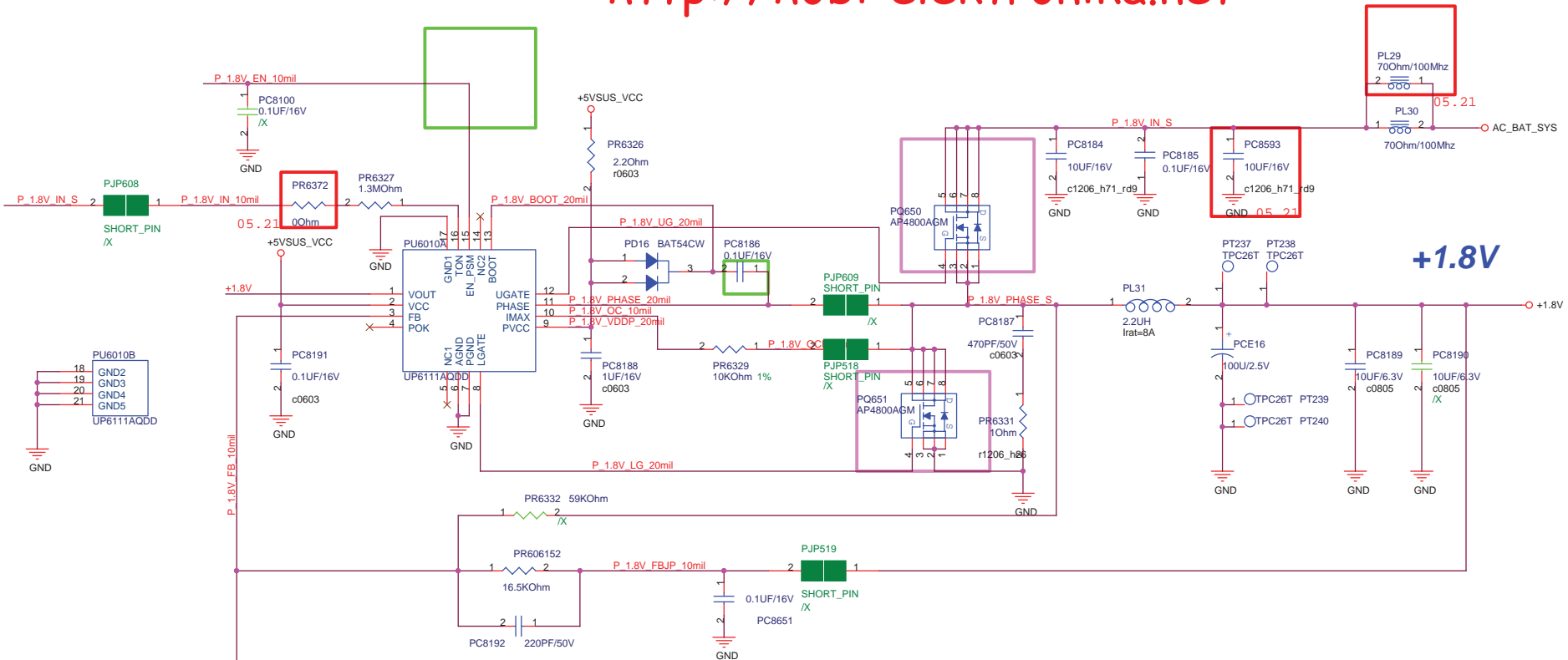

+1.8V_UP	+1.8V_DOWN#	+1.8V
H	H	1.8V
L	H	1.7V
H	L	NO CARE
L	L	1.65V

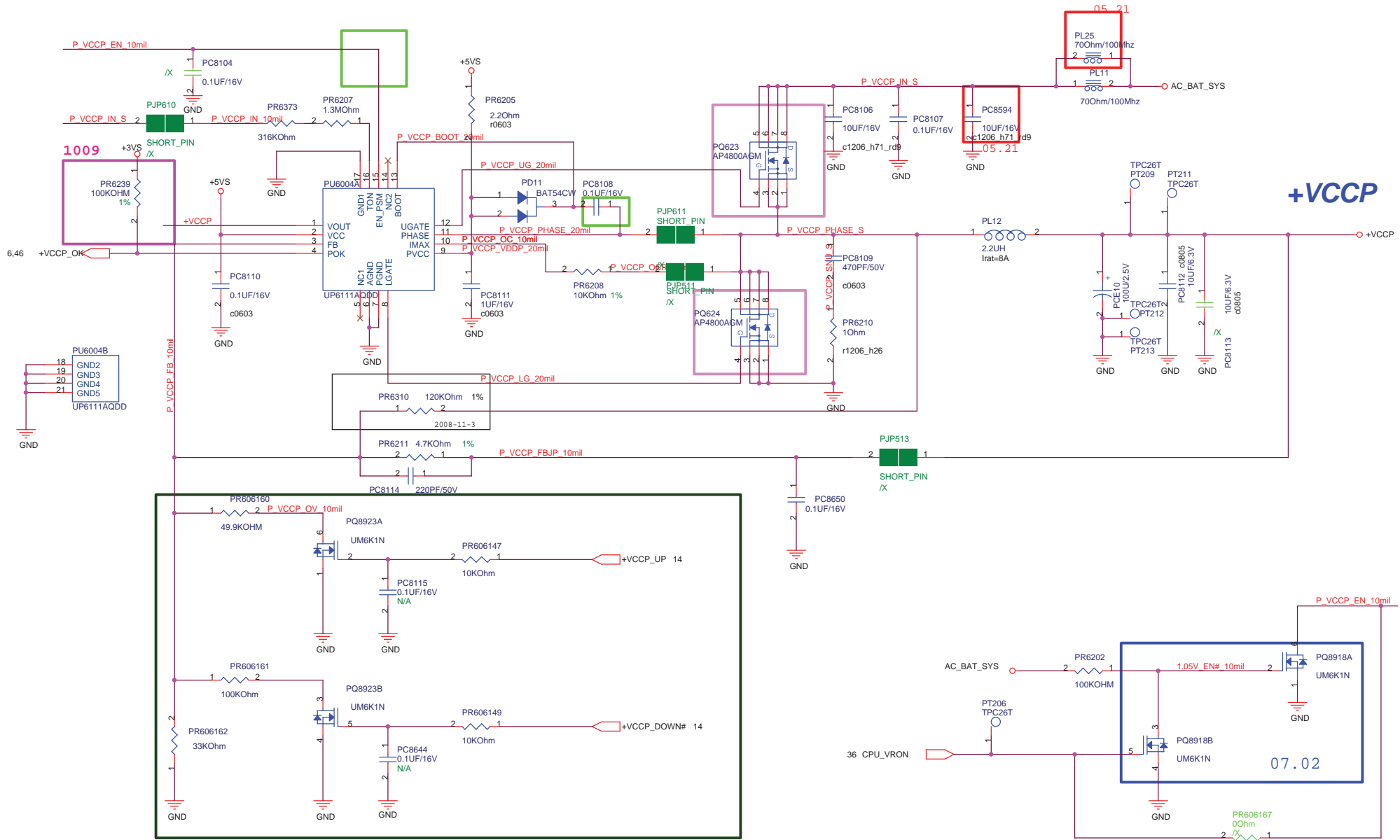

+VCCP

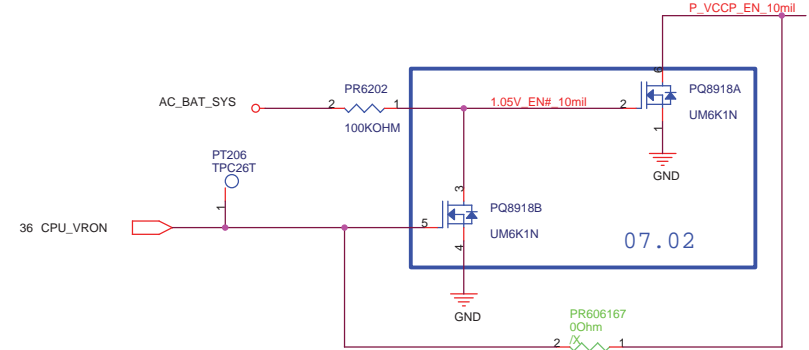
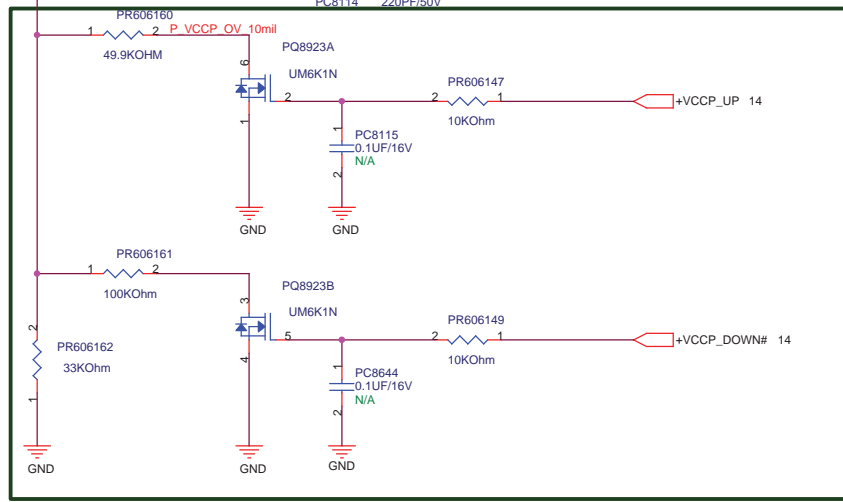

+VCCP_UP	+VCCP_DOWN#	+VCCP	
H	H	0.96V	0.955V
L	H	0.89V	0.886V
H	L	NO CARE	
L	L	0.85V	0.852V

Default Group-A7V/8X MX

ASUS Title : VCCP

ASUSTek Computer INC. Engineer: Joy_Zhou

Size	Project Name	Rev
A3	900SD MB	R1.0G

Date: Monday, November 10, 2008 Sheet 50 of 51

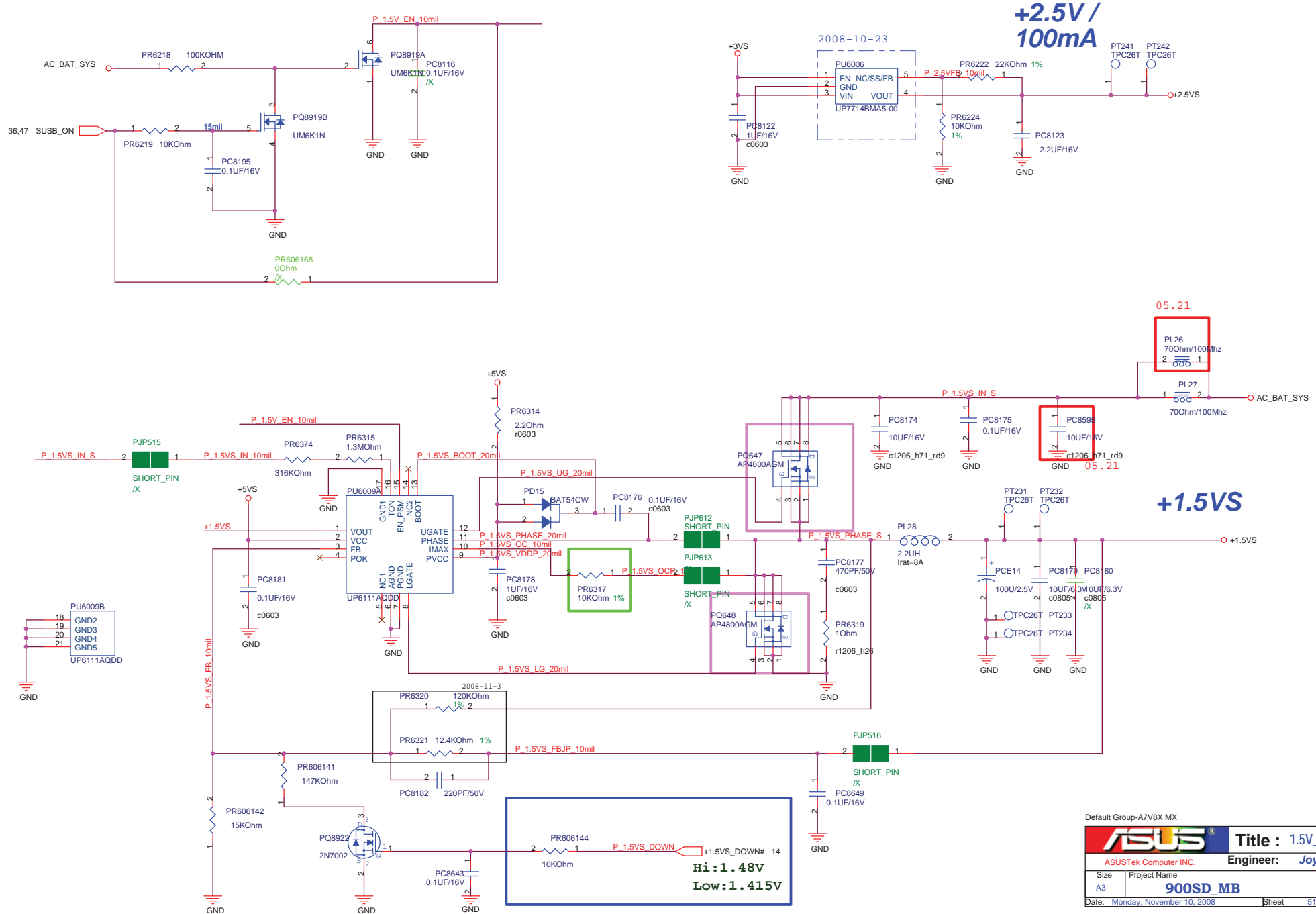

Default Group-A7V8X MX

ASUS		Title : 1.5V_2.5V	
ASUSTek Computer INC.		Engineer: <i>Joy_Zhou</i>	
Size A3	Project Name 900SD_MB	Rev R1.0C	
Date: Monday, November 10, 2008		Sheet	51 of 51