

11/30 Add C647-C653  
Reserved, no need to stuff

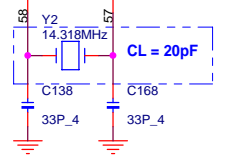

PEREQ1	PECLK Pair0, 6
PEREQ2	PECLK Pair1, 8
PEREQ3	PECLK Pair2, 4
PEREQ4	PECLK Pair3, 5, 7

FSC	FSB	FSA	CPU	SRC	PCI	FSC	FSB	FSA	CPU	SRC	PCI
1	0	1	100	100	33	0	1	0	200	100	33
0	0	1	133	100	33	0	0	0	266	100	33
0	1	1	166	100	33	1	0	0	333	100	33
1	1	1	200	100	33	1	1	0	400	100	33

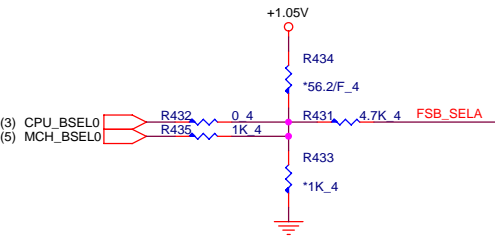
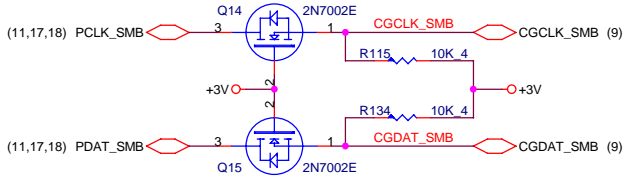
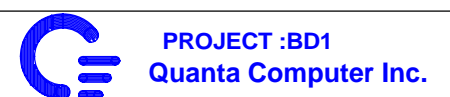
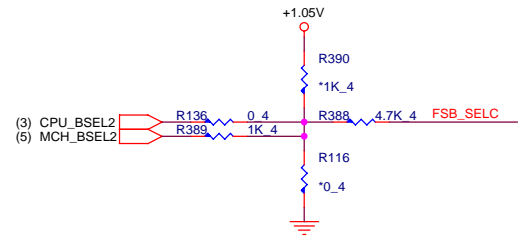



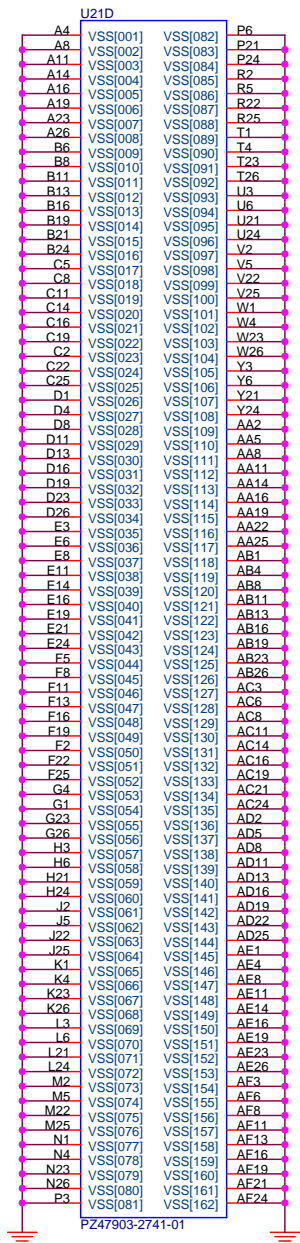

PZ47903-2741-01

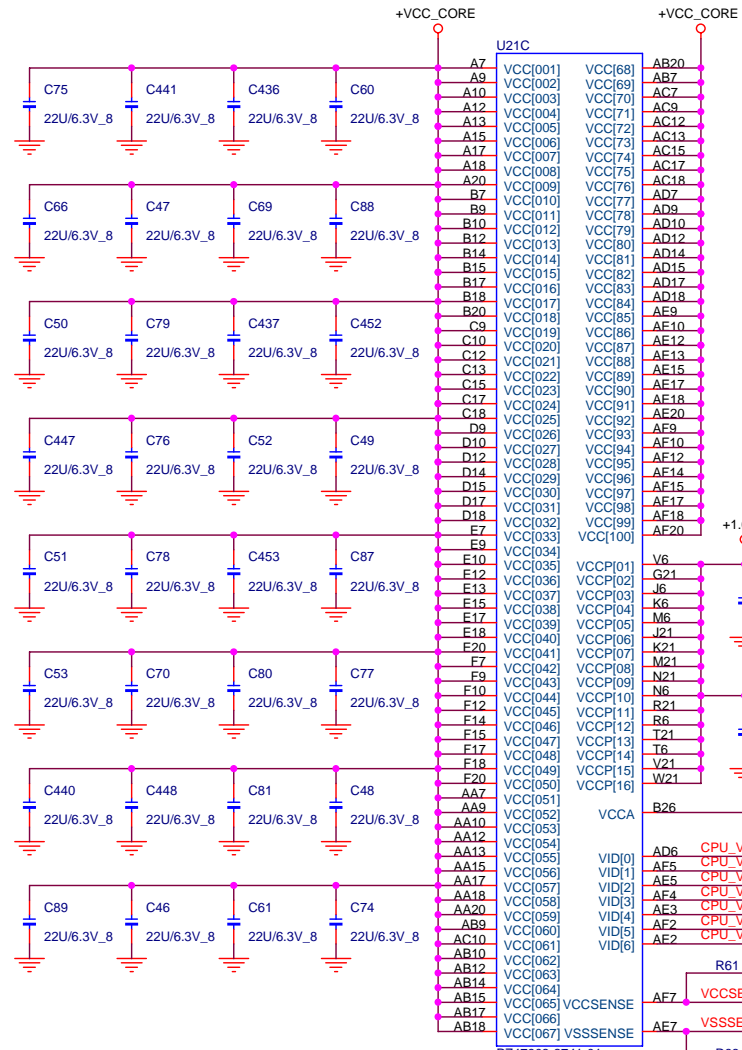

PZ47903-2741-01

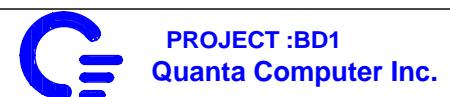
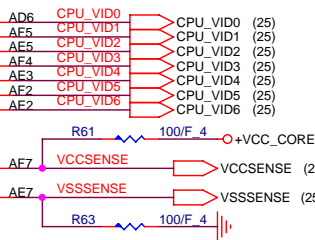
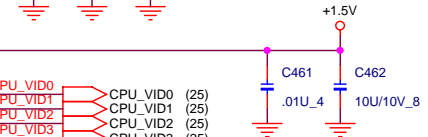
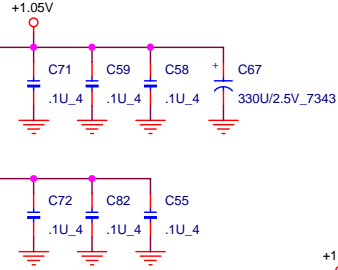
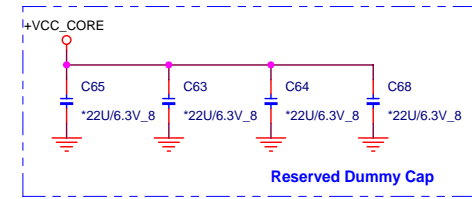
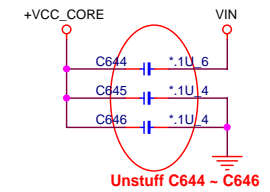

Size	Document Number	Rev
	<b>CPU (POWER)</b>	3B
Date:	Monday, December 12, 2005	Sheet 4 of 32



(9) SMA\_DQ[63..0]

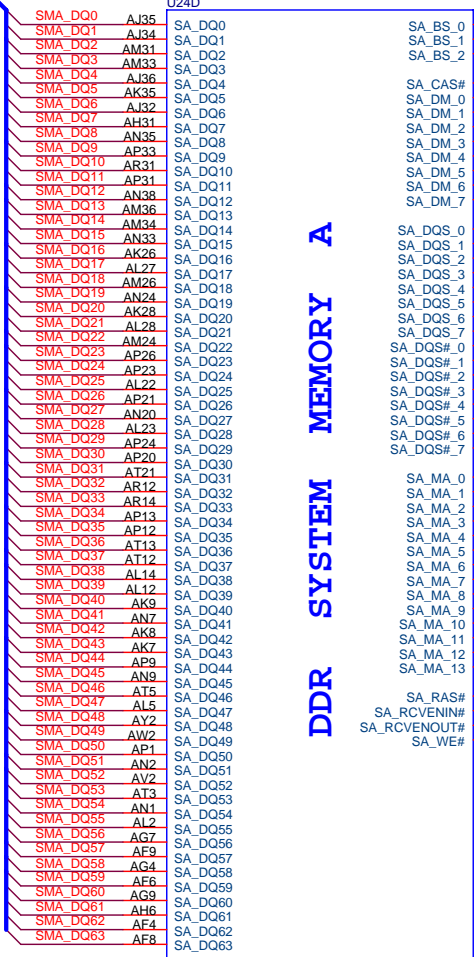

CALISTOGA

(9) SMB\_DQ[63..0]

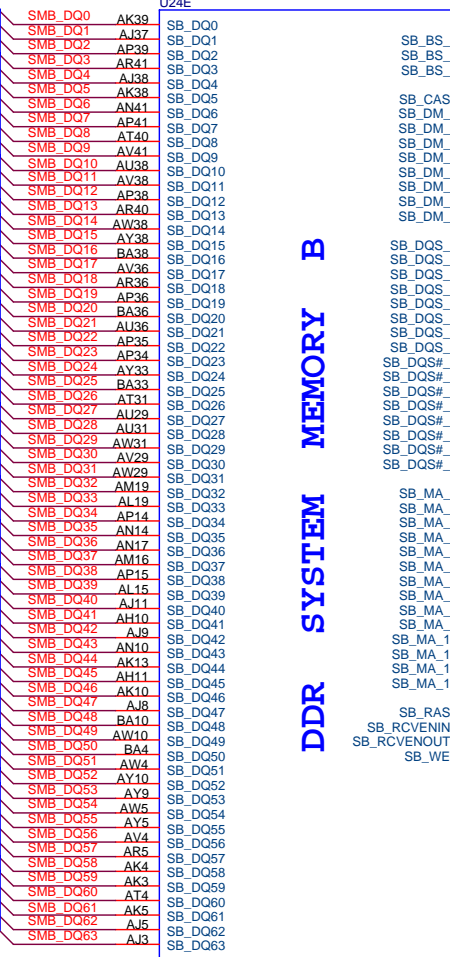

CALISTOGA



PROJECT :BD1  
Quanta Computer Inc.

Size	Document Number	Rev
	<b>GMCH (MEMORY)</b>	3B
Date:	Monday, December 12, 2005	Sheet 6 of 32

U24I	AC41	VSS_0	VSS_97	AK34
	AA41	VSS_1	AK34	AK34
	W41	VSS_2	VSS_98	AF34
	T41	VSS_3	VSS_100	AE34
	P41	VSS_4	VSS_101	W34
	M41	VSS_5	VSS_102	AW33
	J41	VSS_6	VSS_103	AW33
	F41	VSS_7	VSS_104	J23
	AV40	VSS_8	VSS_105	AR33
	AP40	VSS_9	VSS_106	AE33
	AN40	VSS_10	VSS_107	AK22
	AK40	VSS_11	VSS_108	V33
	AL40	VSS_12	VSS_109	G22
	AH40	VSS_13	VSS_110	T33
	AG40	VSS_14	VSS_111	R33
	AF40	VSS_15	VSS_112	M33
	AE40	VSS_16	VSS_113	H33
	B40	VSS_17	VSS_114	F33
	AY39	VSS_18	VSS_115	D33
	AW39	VSS_19	VSS_116	B33
	AV39	VSS_20	VSS_117	R33
	AR39	VSS_21	VSS_118	AH32
	AN39	VSS_22	VSS_119	AK22
	AK39	VSS_23	VSS_120	AE32
	AL39	VSS_24	VSS_121	W21
	AH39	VSS_25	VSS_122	AE32
	AG39	VSS_26	VSS_123	AK22
	AF39	VSS_27	VSS_124	J21
	AE40	VSS_28	VSS_125	C21
	B40	VSS_29	VSS_126	AW20
	AY39	VSS_30	VSS_127	AR20
	AW39	VSS_31	VSS_128	AM20
	AV39	VSS_32	VSS_129	AK20
	AR39	VSS_33	VSS_130	B20
	AN39	VSS_34	VSS_131	Y31
	AK39	VSS_35	VSS_132	AK20
	AL39	VSS_36	VSS_133	AB30
	AH39	VSS_37	VSS_134	E30
	AG39	VSS_38	VSS_135	AC19
	AF39	VSS_39	VSS_136	W19
	AE39	VSS_40	VSS_137	K19
	B39	VSS_41	VSS_138	AB29
	AY38	VSS_42	VSS_139	G19
	AW38	VSS_43	VSS_140	T29
	AV38	VSS_44	VSS_141	AH18
	AR38	VSS_45	VSS_142	P18
	AN38	VSS_46	VSS_143	H18
	AK38	VSS_47	VSS_144	D18
	AL38	VSS_48	VSS_145	A18
	AH38	VSS_49	VSS_146	C29
	AG38	VSS_50	VSS_147	B29
	AF38	VSS_51	VSS_148	A29
	AE38	VSS_52	VSS_149	BA28
	C38	VSS_53	VSS_150	AM17
	C38	VSS_54	VSS_151	AK17
	AK37	VSS_55	VSS_152	AV16
	AH37	VSS_56	VSS_153	AM16
	AG37	VSS_57	VSS_154	AN16
	AF37	VSS_58	VSS_155	AL16
	AE37	VSS_59	VSS_156	I16
	C37	VSS_60	VSS_157	F16
	C37	VSS_61	VSS_158	J28
	H37	VSS_62	VSS_159	E28
	G37	VSS_63	VSS_160	AN15
	F37	VSS_64	VSS_161	AM15
	D37	VSS_65	VSS_162	AK15
	AV36	VSS_66	VSS_163	M15
	AW36	VSS_67	VSS_164	G27
	AV36	VSS_68	VSS_165	F27
	AN36	VSS_69	VSS_166	A15
	AK36	VSS_70	VSS_167	BA14
	AL36	VSS_71	VSS_168	AT14
	AH36	VSS_72	VSS_169	AK14
	AG36	VSS_73	VSS_170	K26
	AF36	VSS_74	VSS_171	AD14
	AE36	VSS_75	VSS_172	F26
	C36	VSS_76	VSS_173	AA14
	B36	VSS_77	VSS_174	H14
	BA35	VSS_78	VSS_175	E25
	AV35	VSS_79	VSS_176	D25
	AR35	VSS_80	VSS_177	K14
	AH35	VSS_81	VSS_178	E14
	AG35	VSS_82	VSS_179	H25
	AF35	VSS_83	VSS_180	AV13
	AE35	VSS_84	VSS_181	AR13
	C35	VSS_85	VSS_182	AN13
	P35	VSS_86	VSS_183	AM13
	N35	VSS_87	VSS_184	AL13
	M35	VSS_88	VSS_185	AG13
	L35	VSS_89	VSS_186	AT13
	J35	VSS_90	VSS_187	AK13
	H35	VSS_91	VSS_188	AD14
	G35	VSS_92	VSS_189	F26
	F35	VSS_93	VSS_190	AA14
	D35	VSS_94	VSS_191	H14
	C35	VSS_95	VSS_192	E14
	AN34	VSS_96	VSS_193	H25
			VSS_194	AV13
			VSS_195	AR13
			VSS_196	AN13
			VSS_197	AM13
			VSS_198	AL13
			VSS_199	AG13
			VSS_200	AT13
			VSS_201	AK13
			VSS_202	AD14
			VSS_203	F26
			VSS_204	AA14
			VSS_205	H14
			VSS_206	E14
			VSS_207	H25
			VSS_208	AV13
			VSS_209	AR13
			VSS_210	AN13
			VSS_211	AM13
			VSS_212	AL13
			VSS_213	AG13
			VSS_214	AT13
			VSS_215	AK13
			VSS_216	AD14
			VSS_217	F26
			VSS_218	AA14
			VSS_219	H14
			VSS_220	E14
			VSS_221	H25
			VSS_222	AV13
			VSS_223	AR13
			VSS_224	AN13
			VSS_225	AM13
			VSS_226	AL13
			VSS_227	AG13
			VSS_228	AT13
			VSS_229	AK13
			VSS_230	AD14
			VSS_231	F26
			VSS_232	AA14
			VSS_233	H14
			VSS_234	E14
			VSS_235	H25
			VSS_236	AV13
			VSS_237	AR13
			VSS_238	AN13
			VSS_239	AM13
			VSS_240	AL13
			VSS_241	AG13
			VSS_242	AT13
			VSS_243	AK13
			VSS_244	AD14
			VSS_245	F26
			VSS_246	AA14
			VSS_247	H14
			VSS_248	E14
			VSS_249	H25
			VSS_250	AV13
			VSS_251	AR13
			VSS_252	AN13
			VSS_253	AM13
			VSS_254	AL13
			VSS_255	AG13
			VSS_256	AT13
			VSS_257	AK13
			VSS_258	AD14
			VSS_259	F26
			VSS_260	AA14
			VSS_261	H14
			VSS_262	E14
			VSS_263	H25
			VSS_264	AV13
			VSS_265	AR13
			VSS_266	AN13
			VSS_267	AM13
			VSS_268	AL13
			VSS_269	AG13
			VSS_270	AT13
			VSS_271	AK13
			VSS_272	AD14
			VSS_273	F26
			VSS_274	AA14
			VSS_275	H14
			VSS_276	E14
			VSS_277	H25
			VSS_278	AV13
			VSS_279	AR13
			VSS_280	AN13
			VSS_281	AM13
			VSS_282	AL13
			VSS_283	AG13
			VSS_284	AT13
			VSS_285	AK13
			VSS_286	AD14
			VSS_287	F26
			VSS_288	AA14
			VSS_289	H14
			VSS_290	E14
			VSS_291	H25
			VSS_292	AV13
			VSS_293	AR13
			VSS_294	AN13
			VSS_295	AM13
			VSS_296	AL13
			VSS_297	AG13
			VSS_298	AT13
			VSS_299	AK13
			VSS_300	AD14
			VSS_301	F26
			VSS_302	AA14
			VSS_303	H14
			VSS_304	E14
			VSS_305	H25
			VSS_306	AV13
			VSS_307	AR13
			VSS_308	AN13
			VSS_309	AM13
			VSS_310	AL13
			VSS_311	AG13
			VSS_312	AT13
			VSS_313	AK13
			VSS_314	AD14
			VSS_315	F26
			VSS_316	AA14
			VSS_317	H14
			VSS_318	E14
			VSS_319	H25
			VSS_320	AV13
			VSS_321	AR13
			VSS_322	AN13
			VSS_323	AM13
			VSS_324	AL13
			VSS_325	AG13
			VSS_326	AT13
			VSS_327	AK13
			VSS_328	AD14
			VSS_329	F26
			VSS_330	AA14
			VSS_331	H14
			VSS_332	E14
			VSS_333	H25
			VSS_334	AV13
			VSS_335	AR13
			VSS_336	AN13
			VSS_337	AM13
			VSS_338	AL13
			VSS_339	AG13
			VSS_340	AT13
			VSS_341	AK13
			VSS_342	AD14
			VSS_343	F26
			VSS_344	AA14
			VSS_345	H14
			VSS_346	E14
			VSS_347	H25
			VSS_348	AV13
			VSS_349	AR13
			VSS_350	AN13
			VSS_351	AM13
			VSS_352	AL13
			VSS_353	AG13
			VSS_354	AT13
			VSS_355	AK13
			VSS_356	AD14
			VSS_357	F26
			VSS_358	AA14
			VSS_359	H14
			VSS_360	E14

U24J	AT23	VSS_180	J11
	AN23	VSS_181	D11
	AM23	VSS_182	B11
	AH23	VSS_183	AV10
	AG23	VSS_184	AP10
	W23	VSS_185	AL10
	K23	VSS_186	AL10
	J23	VSS_187	AG10
	F23	VSS_188	AC10
	C23	VSS_189	W10
	AA22	VSS_190	L10
	AK22	VSS_191	BA9
	G22	VSS_192	AW9
	K22	VSS_193	AR9
	F22	VSS_194	AH9
	E22	VSS_195	AB9
	D22	VSS_196	AD9
	A22	VSS_197	LA8
	BA21	VSS_198	LA8
	AV21	VSS_199	LA8
	AR21	VSS_200	LA8
	AN21	VSS_201	LA8
	AL21	VSS_202	LA8
	AG21	VSS_203	LA8
	AT21	VSS_204	LA8
	AK21	VSS_205	LA8
	G21	VSS_206	LA8
	K21	VSS_207	LA8
	F21	VSS_208	LA8
	E21	VSS_209	LA8
	D21	VSS_210	LA8
	A21	VSS_211	LA8
	BA20	VSS_212	LA8
	AV20	VSS_213	LA8
	AR20	VSS_214	LA8
	AN20	VSS_215	LA8
	AL20	VSS_216	LA8
	AG20	VSS_217	LA8
	AT20	VSS_218	LA8
	AK20	VSS_219	LA8
	G20	VSS_220	LA8
	K20	VSS_221	LA8
	F20	VSS_222	LA8
	E20	VSS_223	LA8
	D20	VSS_224	LA8
	A20	VSS_225	LA8
	BA19	VSS_226	LA8
	AV19	VSS_227	LA8
	AR19	VSS_228	LA8
	AN19	VSS_229	LA8
	AL19	VSS_230	LA8
	AG19	VSS_231	LA8
	AT19	VSS_232	LA8
	AK19	VSS_233	LA8
	G19	VSS_234	LA8
	K19	VSS_235	LA8
	F19	VSS_236	LA8
	E19	VSS_237	LA8
	D19	VSS_238	LA8
	A19	VSS_239	LA8
	BA18	VSS_240	LA8
	AV18	VSS_241	LA8
	AR18	VSS_242	LA8
	AN18	VSS_243	LA8
	AL18	VSS_244	LA8
	AG18	VSS_245	LA8
	AT18	VSS_246	LA8
	AK18	VSS_247	LA8
	G18	VSS_248	LA8





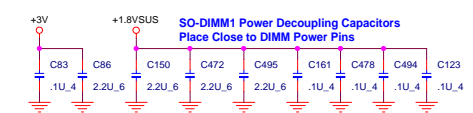
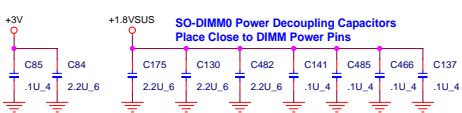
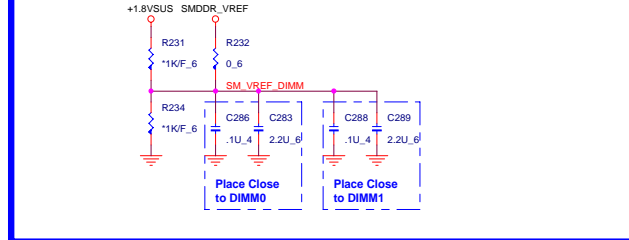
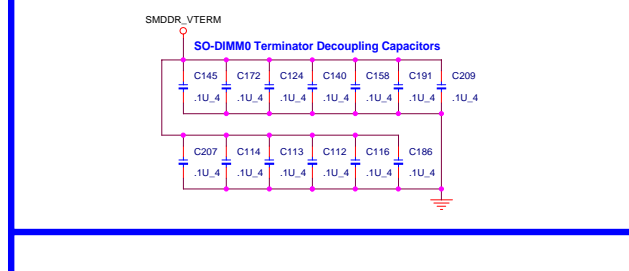
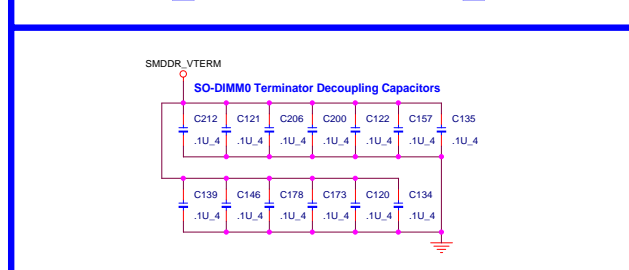
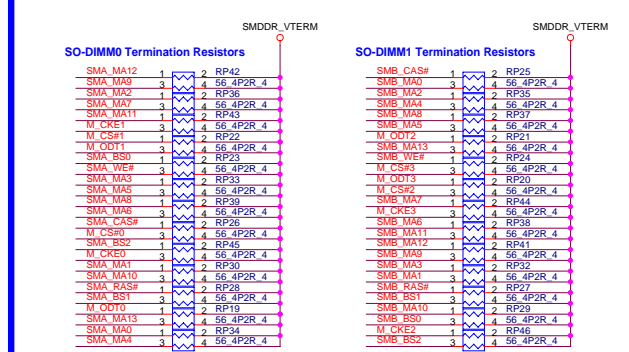
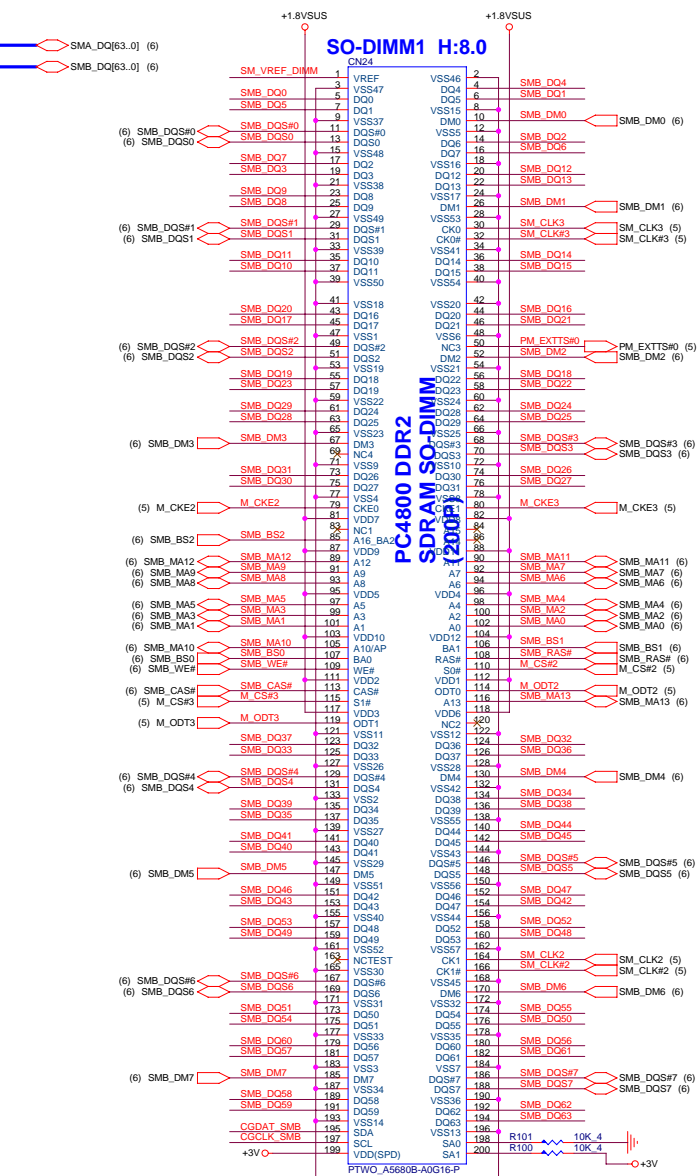
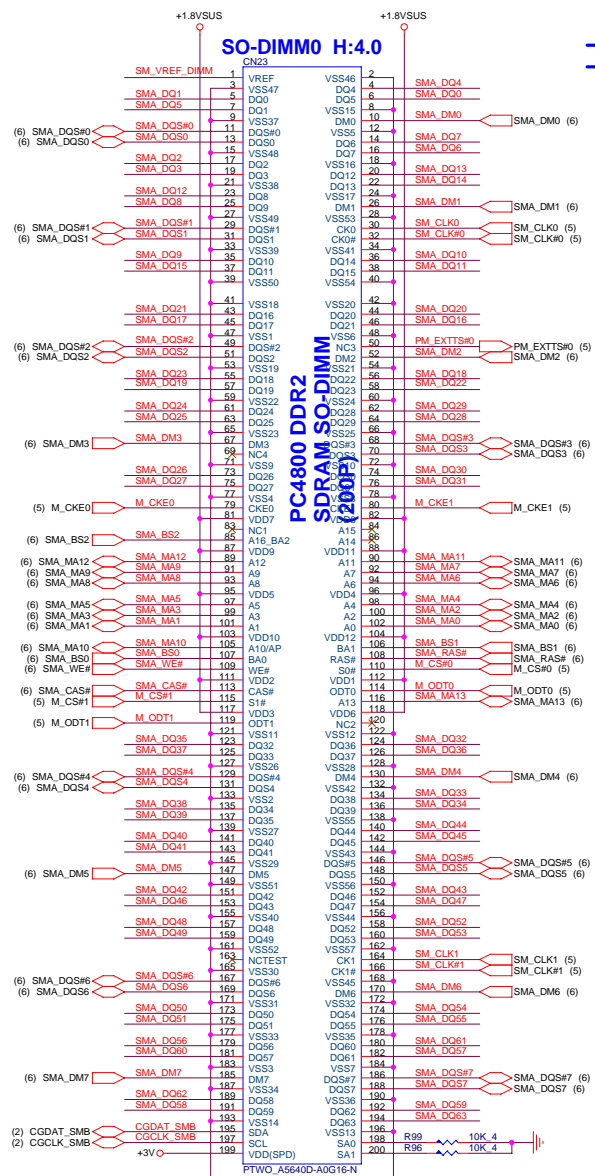

**PROJECT :BD1**  
**Quanta Computer Inc.**

Size: Document Number: **DDR2 SO-DIMM** Rev: 3B  
Date: Monday, December 12, 2005 Sheet: 9 of 32

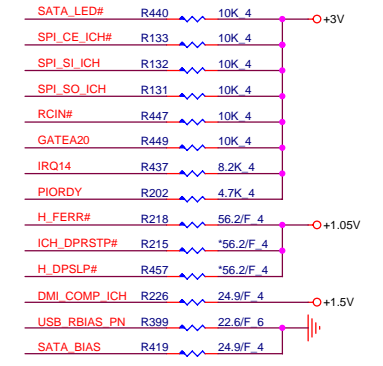
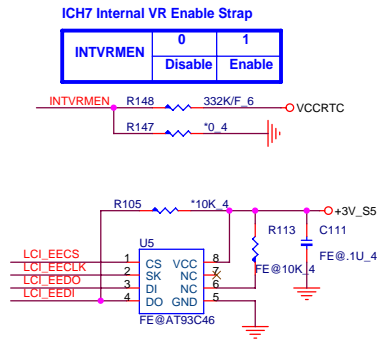
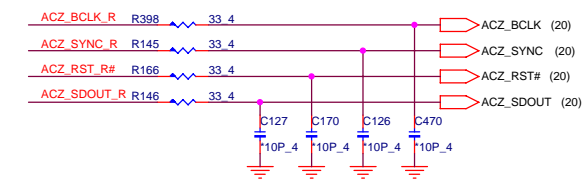
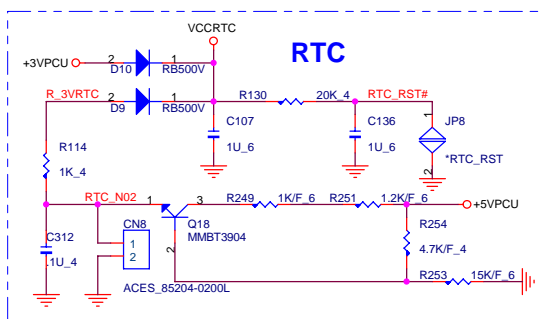
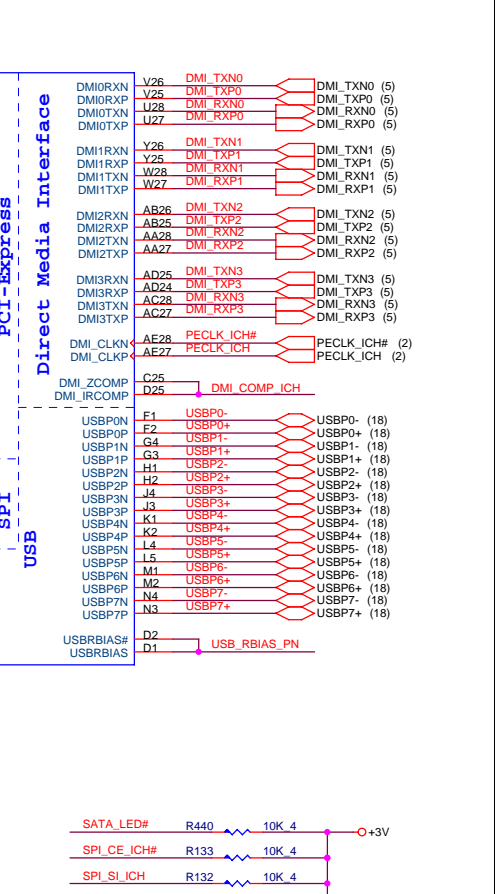
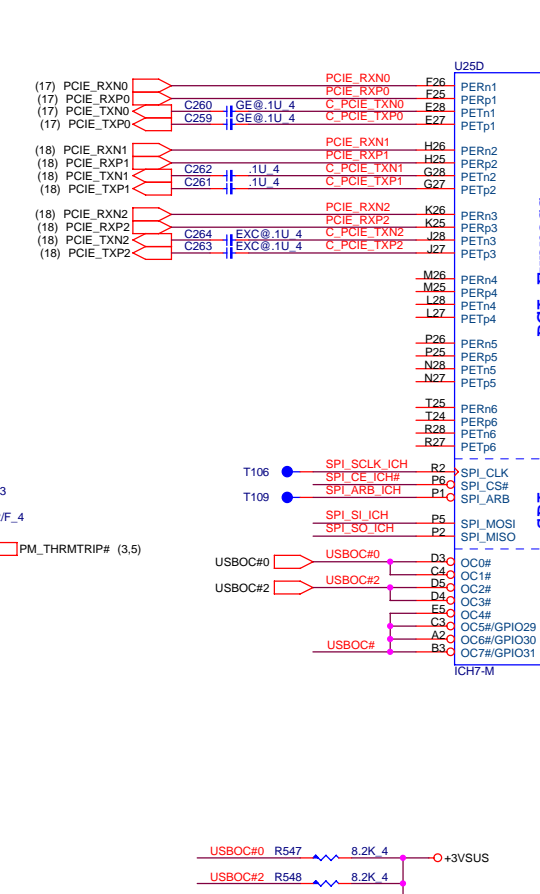
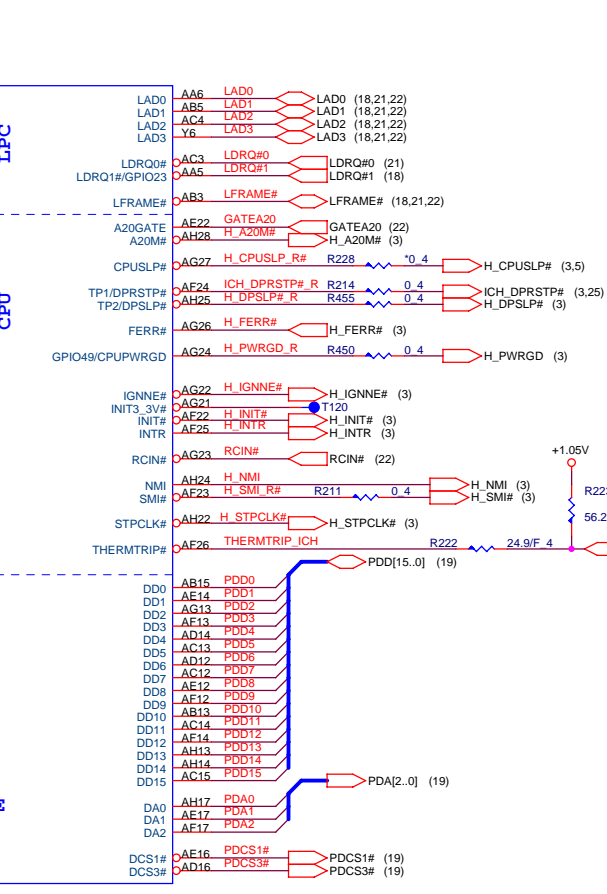
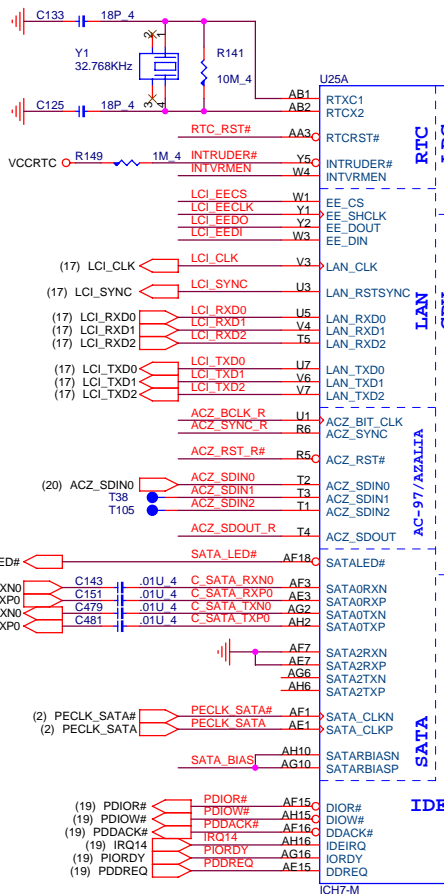

**PROJECT :BD1**  
**Quanta Computer Inc.**

Size	Document Number	Rev
	<b>ICH7-M (CPU, DMI)</b>	3B
Date:	Monday, December 12, 2005	Sheet 10 of 32

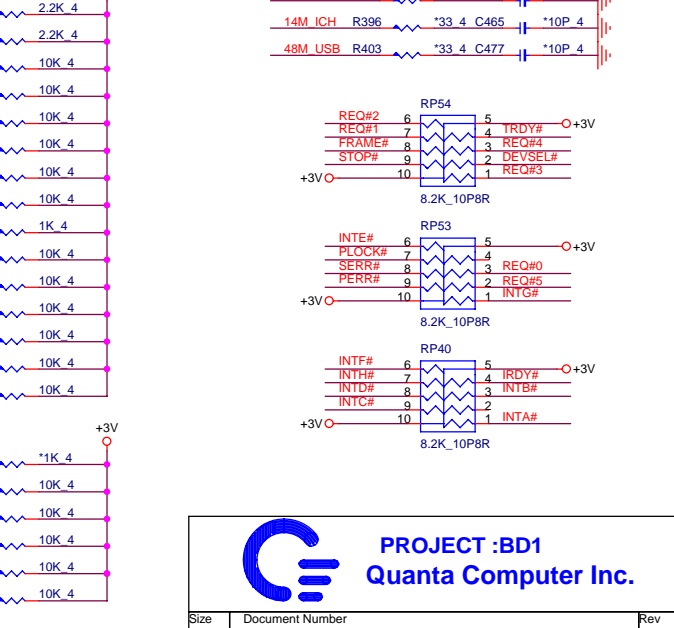
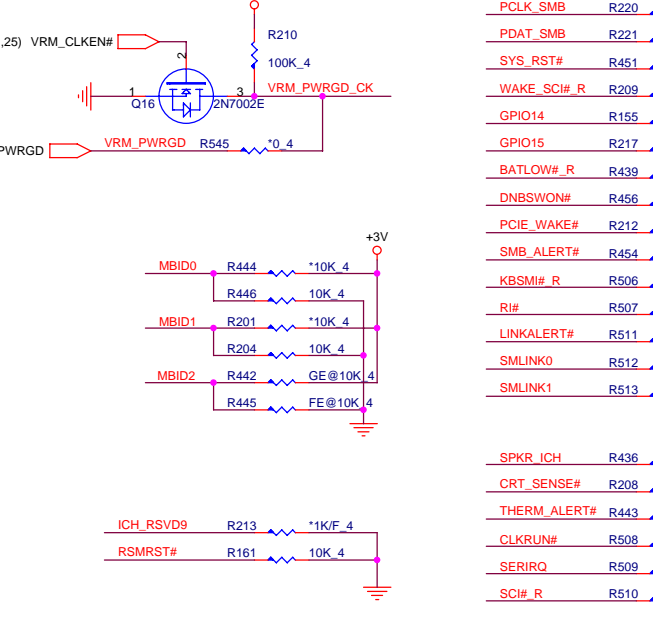
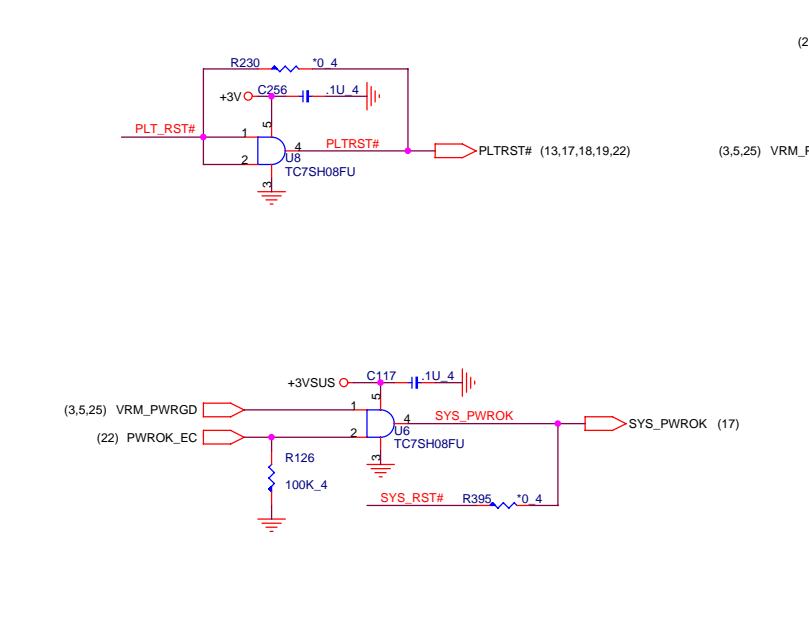
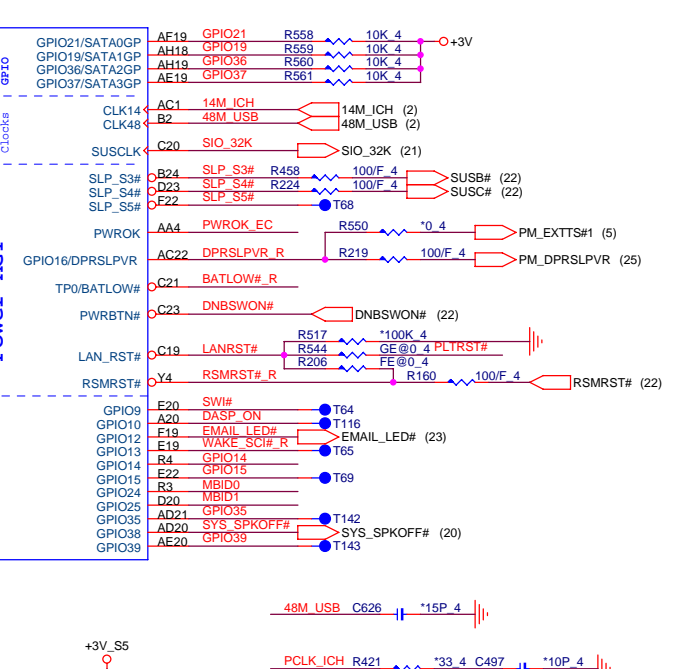
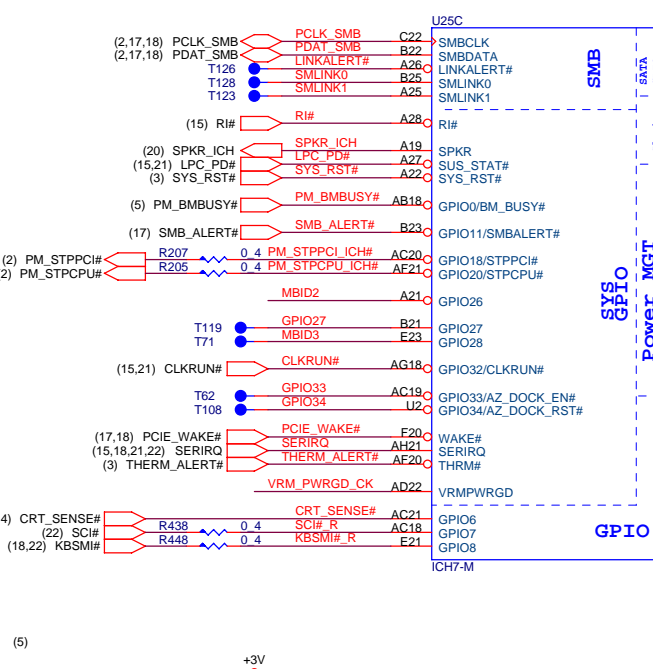
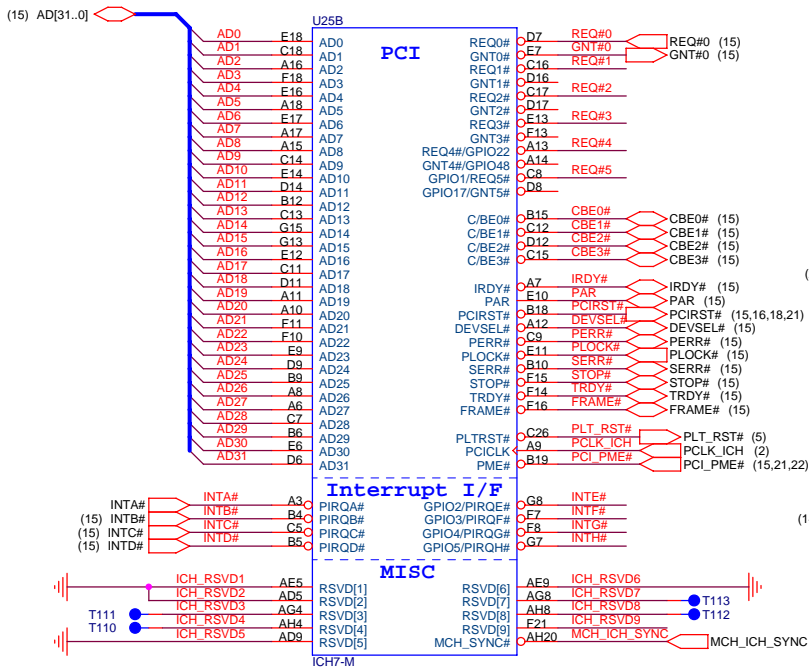

**PROJECT :BD1**  
**Quanta Computer Inc.**

Size	Document Number	Rev
	<b>ICH7-M (PCI, GPIO)</b>	<b>3B</b>
Date:	Monday, December 12, 2005	Sheet 11 of 32



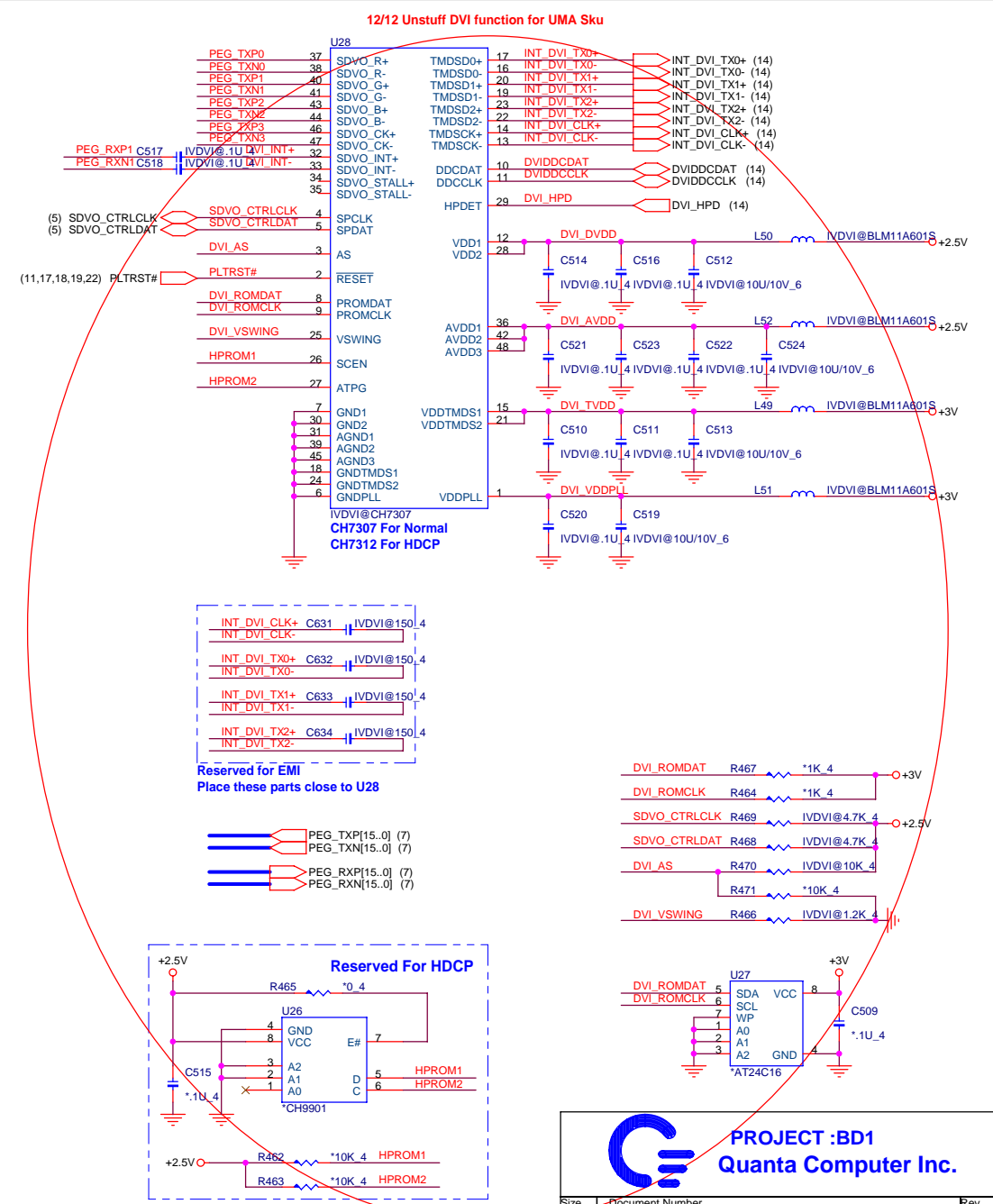
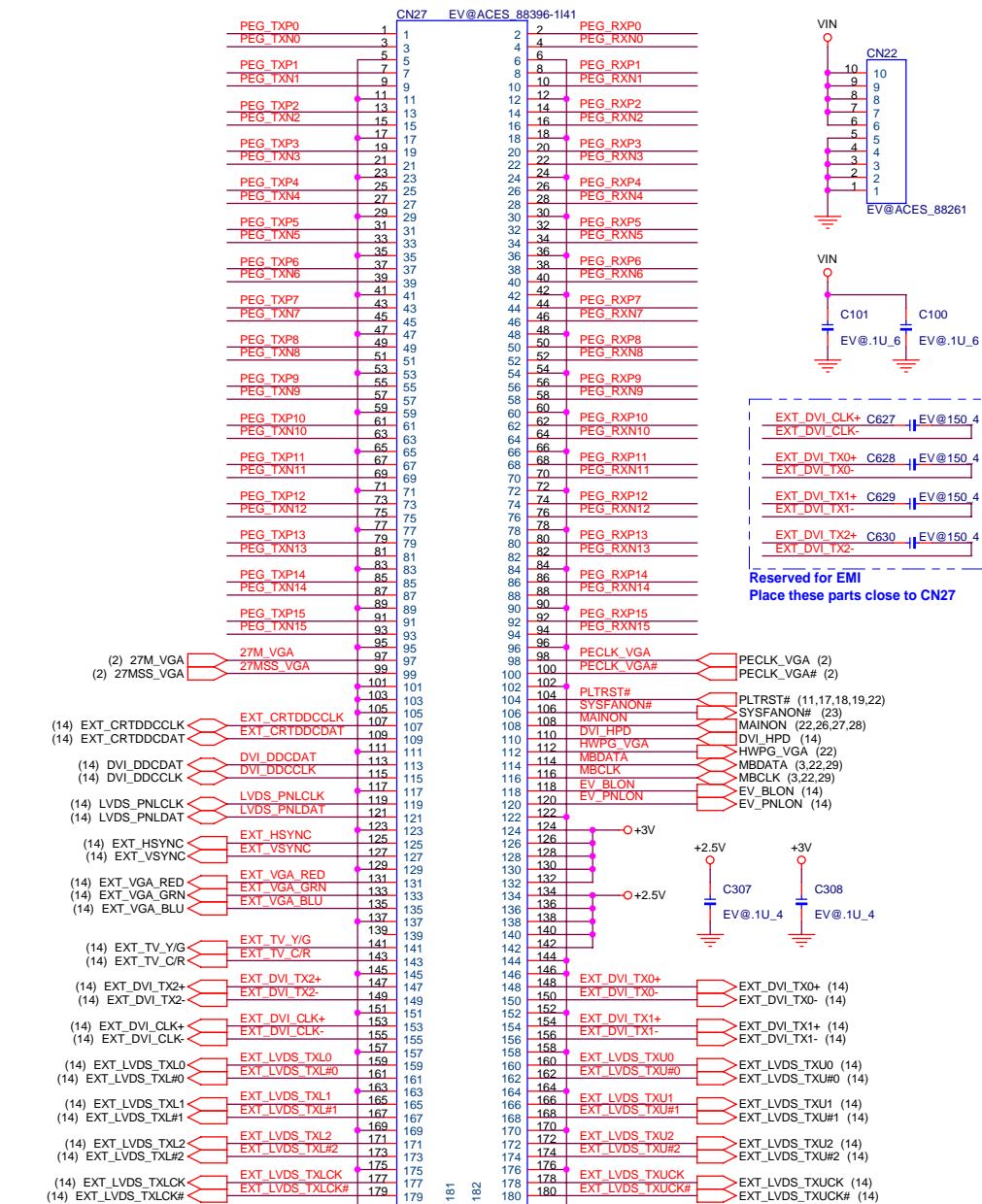

**PROJECT :BD1**  
**Quanta Computer Inc.**

Size	Document Number	Rev
	<b>VGA (CH7307/VGA IF)</b>	3B
Date:	Monday, December 12, 2005	Sheet 13 of 32



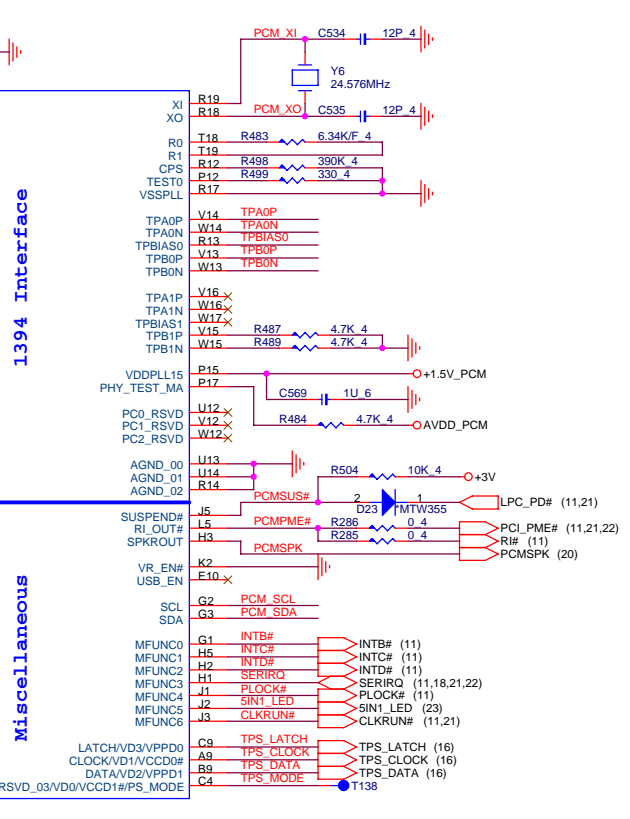
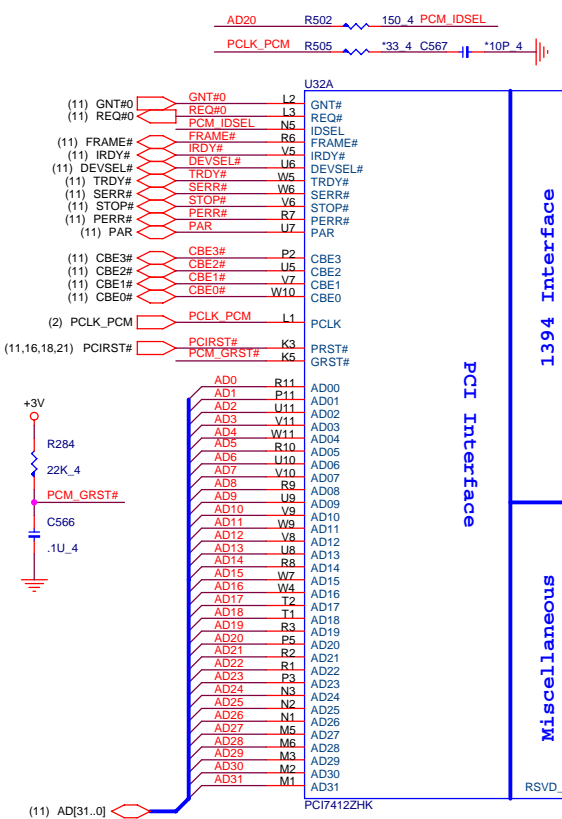

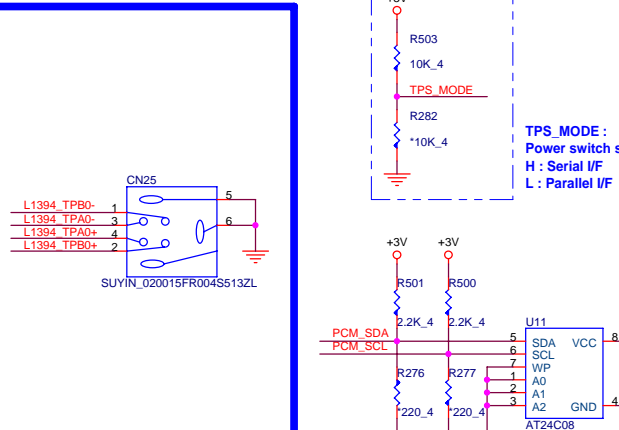
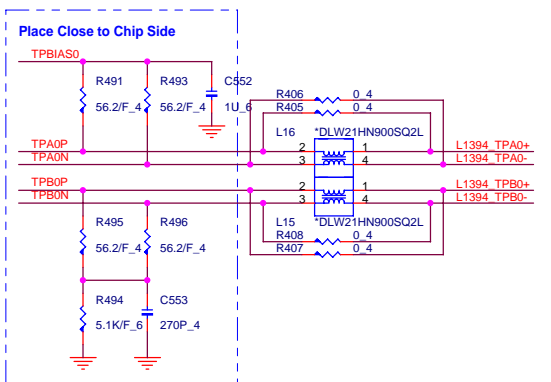

1394

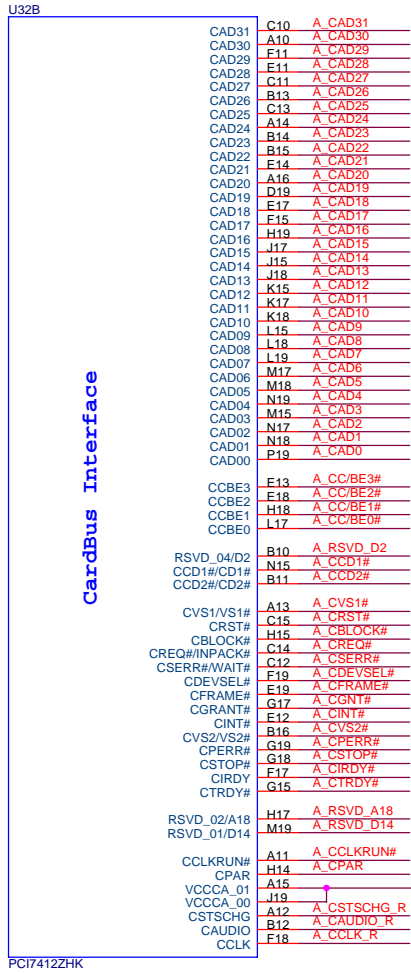

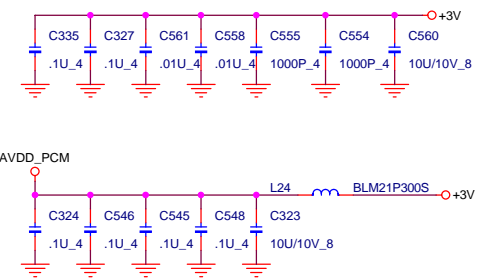
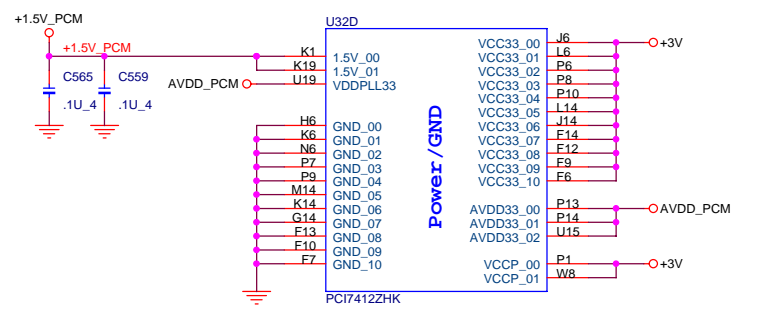
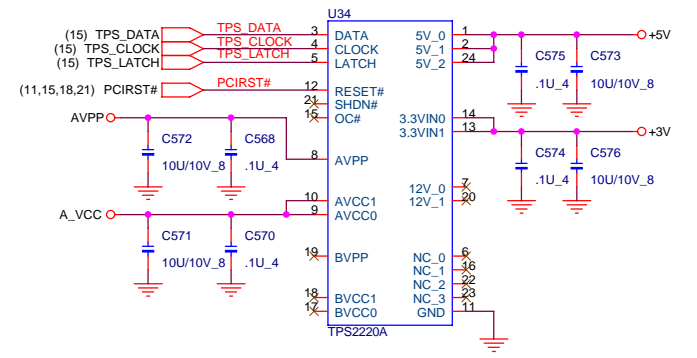
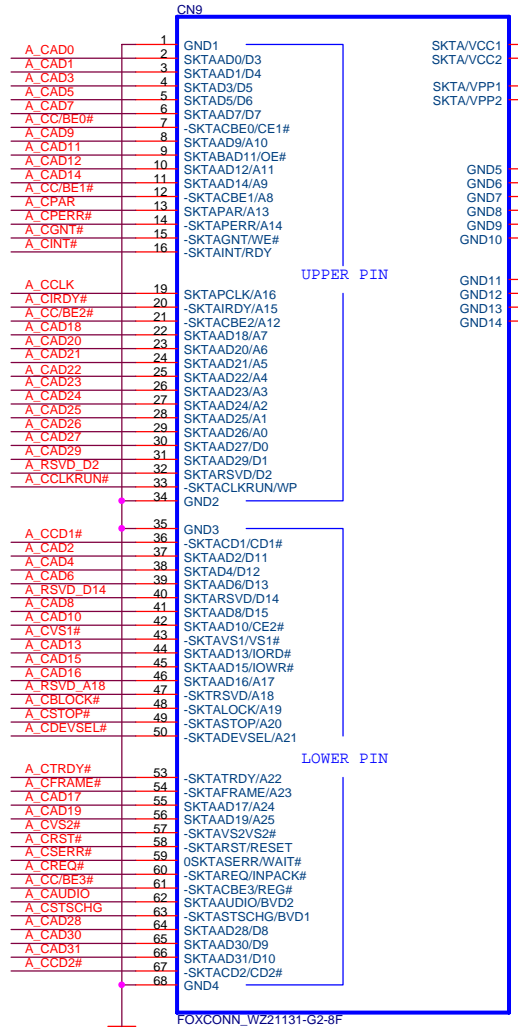

A_CCLK_R	R486	33.4	A_CCLK
A_CSTSCHG_R	R490	0.4	A_CSTSCHG
A_AUDIO_R	R492	0.4	A_AUDIO





**PROJECT :BD1**  
**Quanta Computer Inc.**

Size	Document Number	Rev
	<b>PCI7412 (PCMCIA)</b>	<b>3B</b>
Date:	Monday, December 12, 2005	Sheet 16 of 32





# MINI CARD

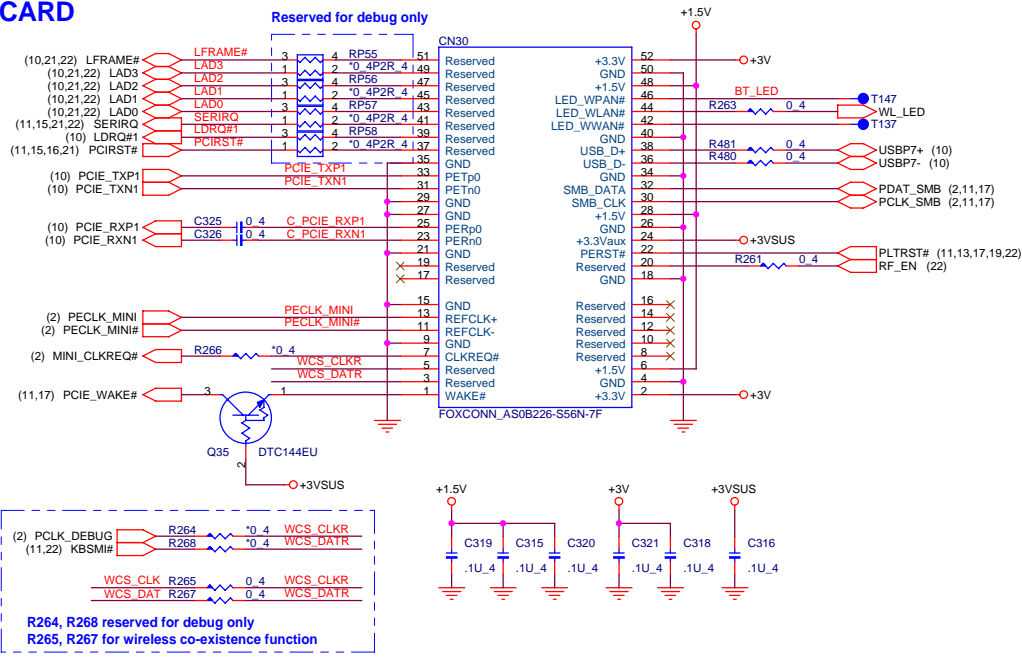

# BLUETOOTH

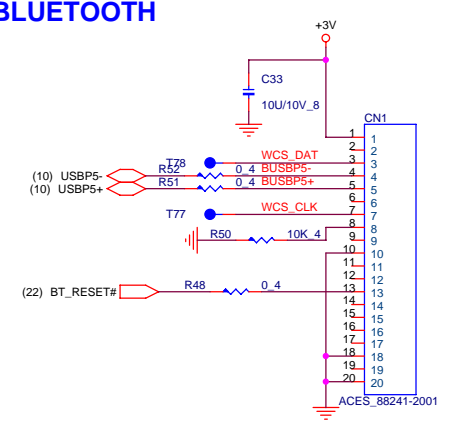

# USB BOARD

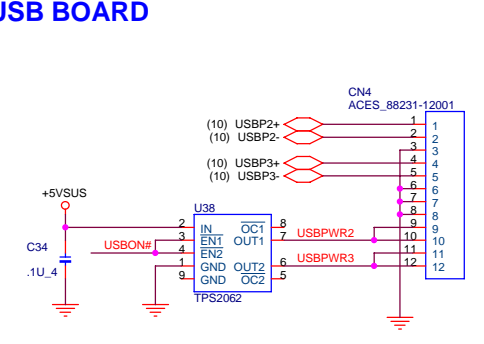

# USB PORT x2

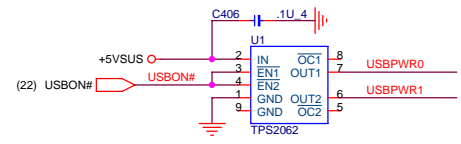

# NEW CARD

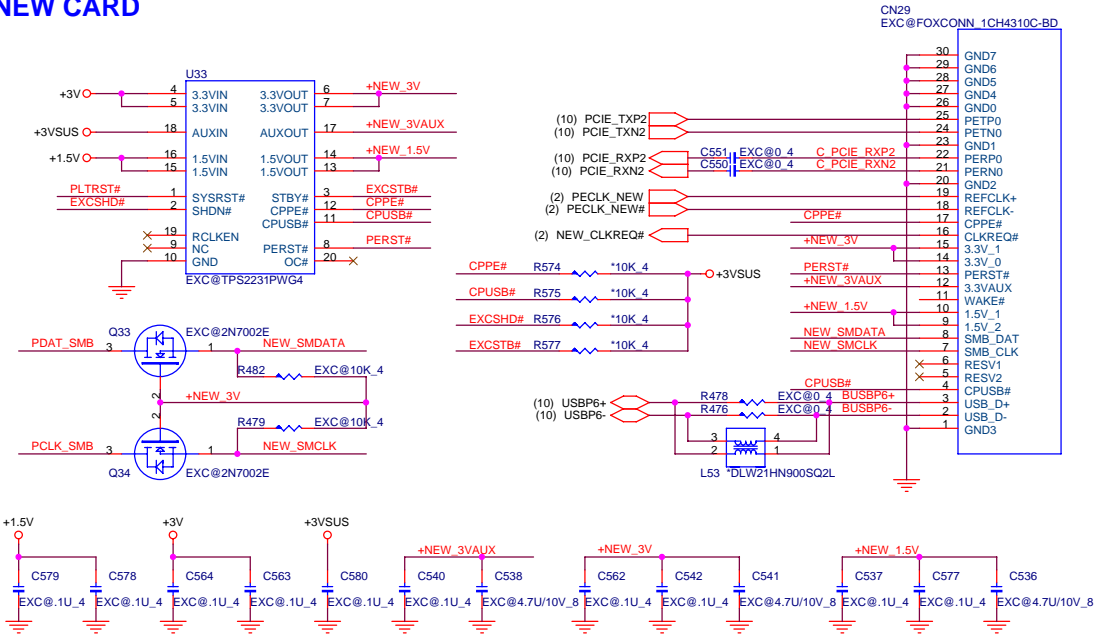

# Fingerprint

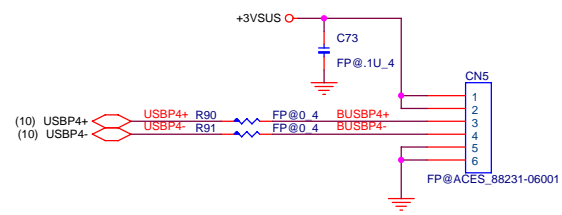

**PROJECT :BD1**  
**Quanta Computer Inc.**

Size	Document Number	Rev
	<b>MINI CARD/NEW CARD/USB</b>	3B
Date:	Monday, December 12, 2005	Sheet 18 of 32

# HDD (SATA)

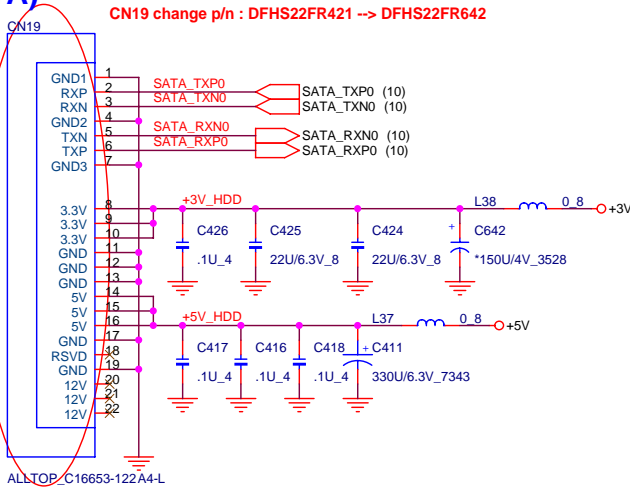

# ODD (PATA)

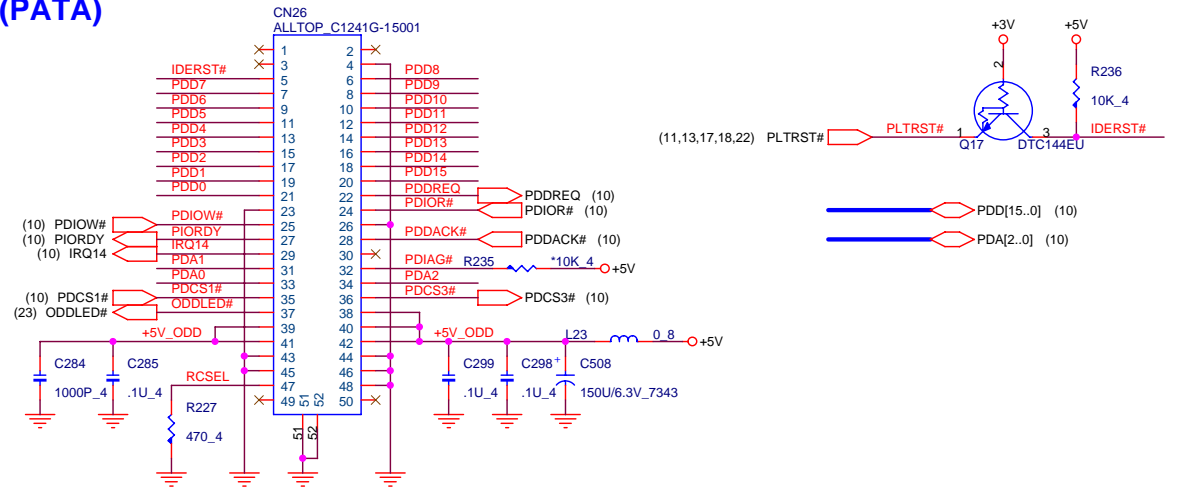

# SCREW HOLE

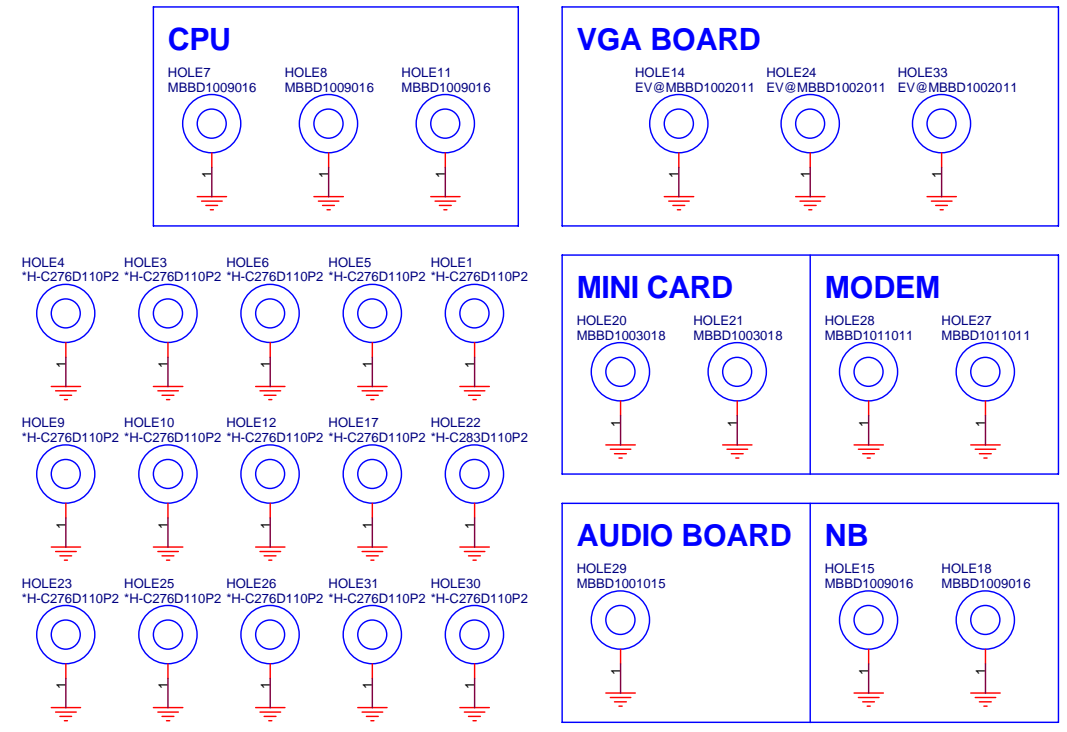

# EMI

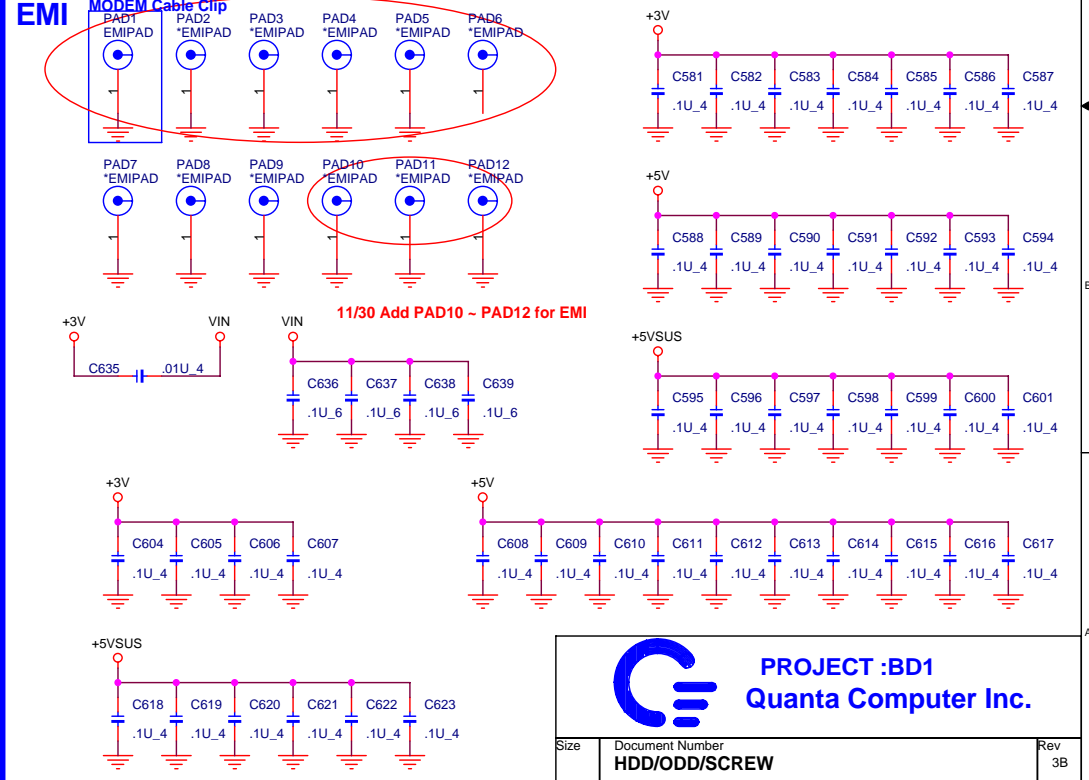



**PROJECT :BD1**  
**Quanta Computer Inc.**

Size	Document Number <b>HDD/ODD/SCREW</b>	Rev 3B
Date:	Monday, December 12, 2005	Sheet 19 of 32

# CODEC

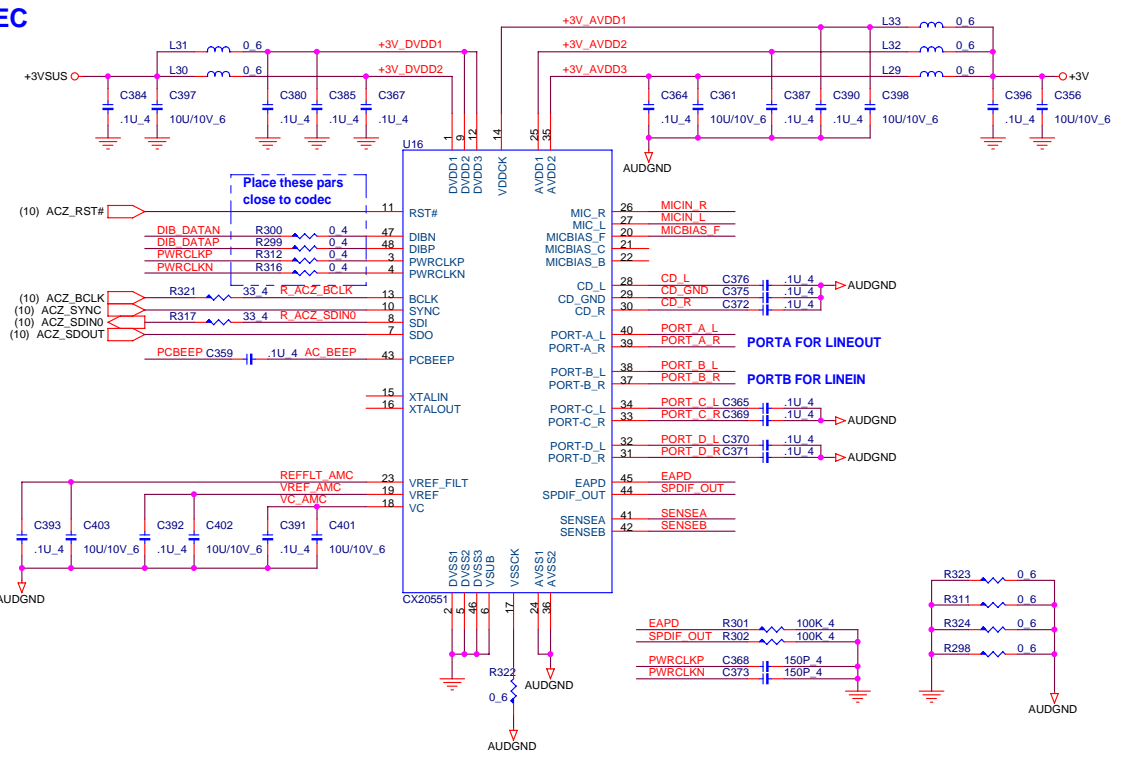

# AMP

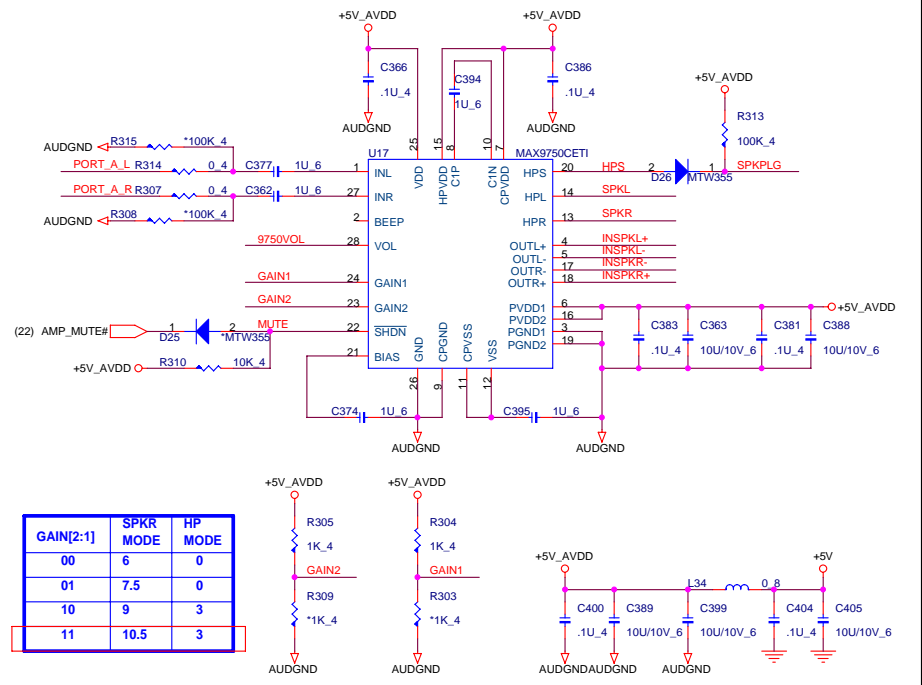

# AUDIO/B

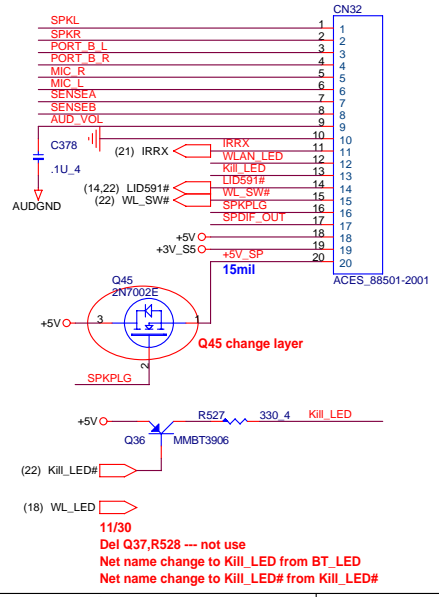

# MIC IN

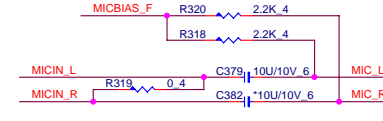

# MODEM/B

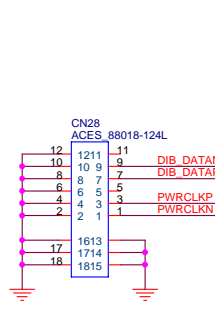

# PC BEEP

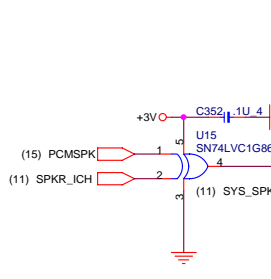

# SPEAKER

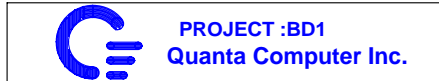
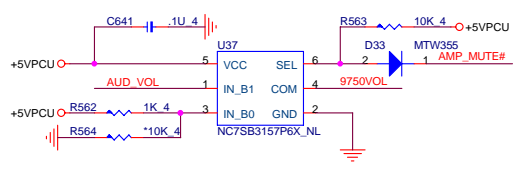
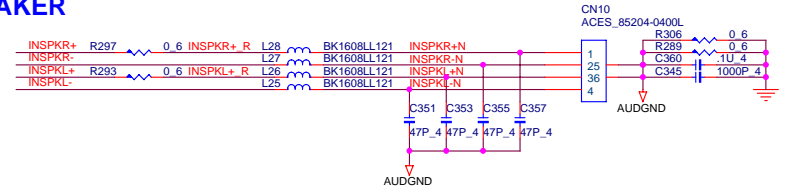

Size	Document Number	Rev
	<b>AUDIO (CODEC/AMP)</b>	3B
Date:	Monday, December 12, 2005	Sheet 20 of 32

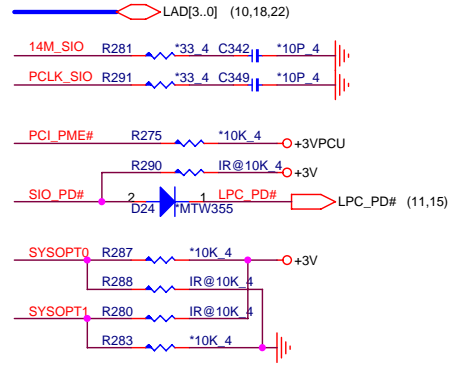
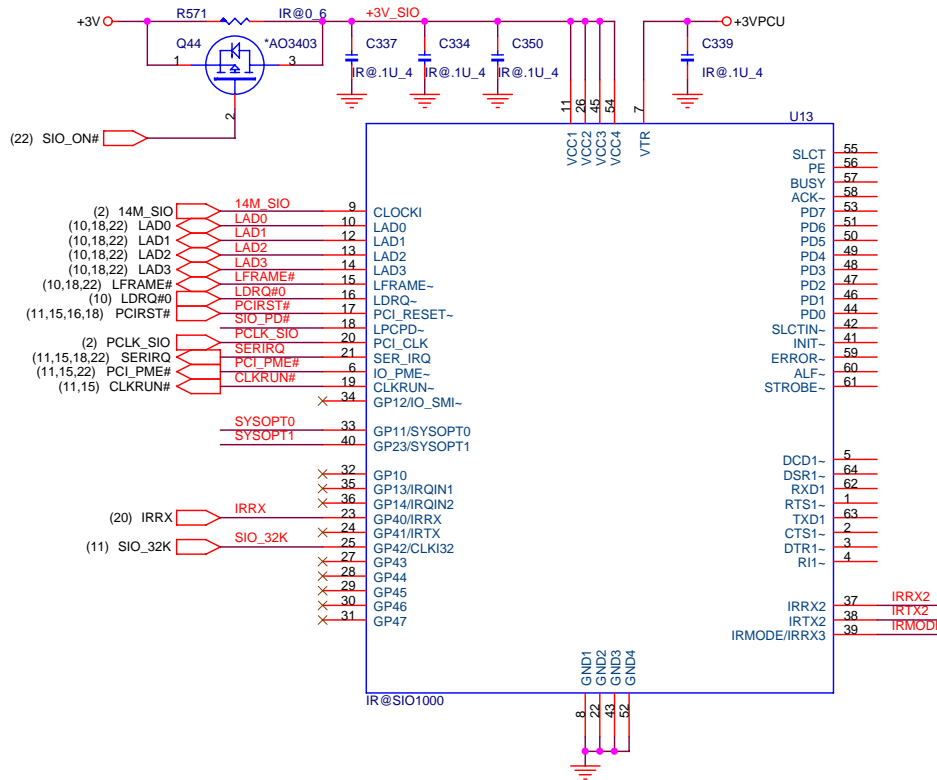

SYSOPT1	SYSOPT0	DEFAULT CONFIGURATION PORT BASE ADDRESS
0	0	0X002E
0	1	0X004E
1	0	0X162E
1	1	0X164E

TPM 1.2

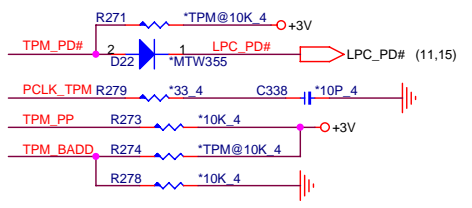
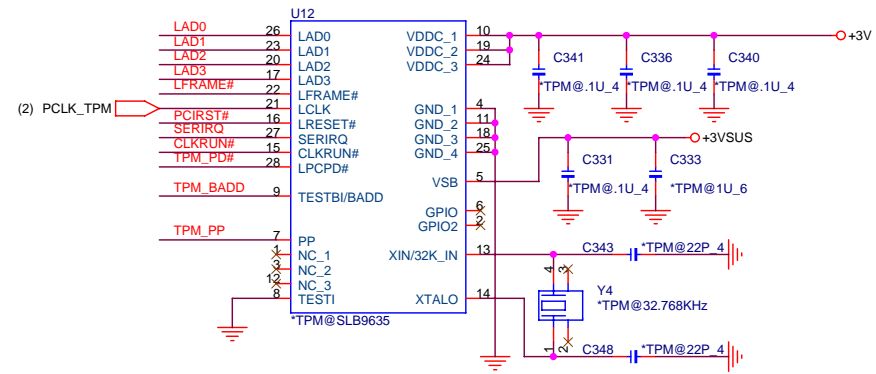

TPM_PP	HI : ACCESS LOW : NORMAL ( Internal PD )
TPM_BADD	HI : 4E/4F h LOW : 2E / 2F h

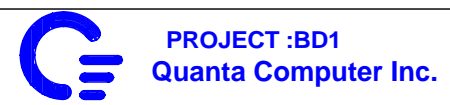

Should have a 0.1uF capacitor close to every GND-VCC pair + one larger cap on the supply.

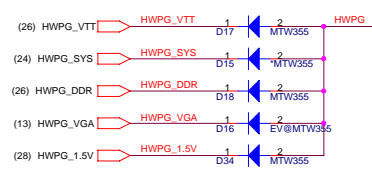
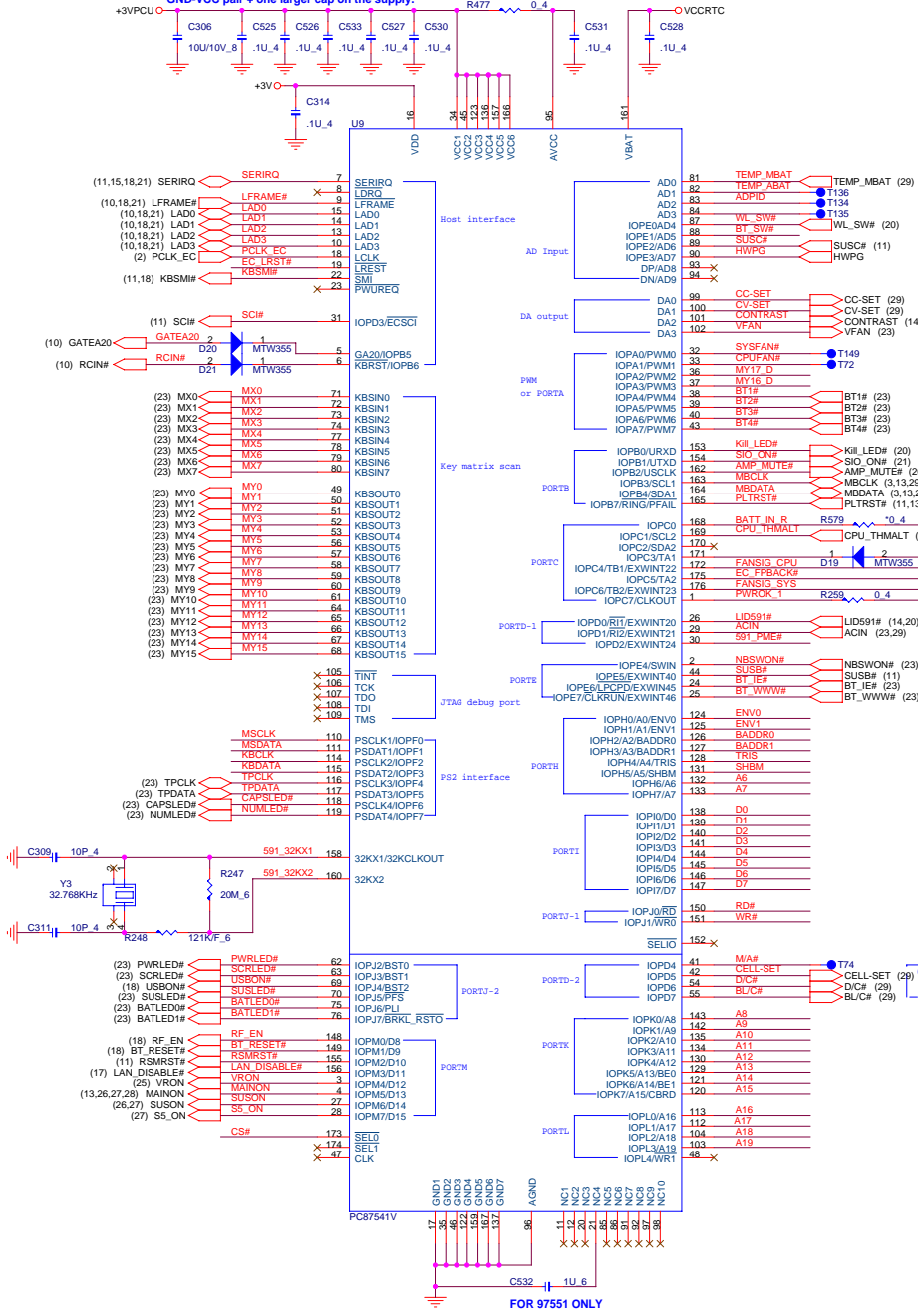

I/O Address		
BADDR1-0	Index	Data
0 0	2E	2F
0 1	4E	4F
1 0	(HCFG8BAH, HCFG8BAL)	(HCFG8BAH, HCFG8BAL)+1
1 1	Reserved	

SHBM=1: Enable shared memory with host BIOS

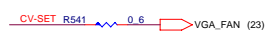
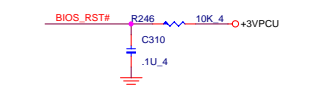
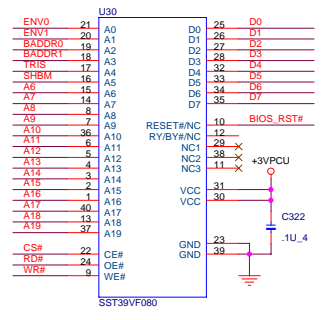
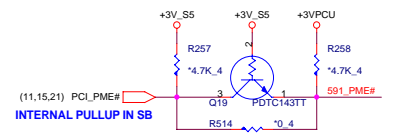
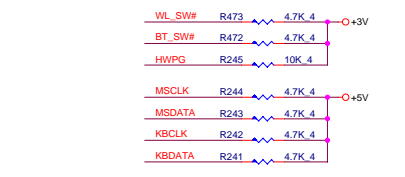
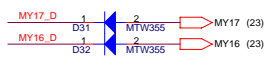
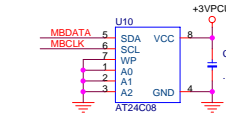
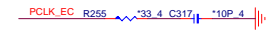

CELL-SET FOR 433P CELL-SET HIGH FOR 333P CELL-SET LOW

**PROJECT :BD1**  
**Quanta Computer Inc.**

Size: Document Number  
**PC87541/FLASH**  
 Rev: 3B

Date: Monday, December 12, 2005  
 Sheet: 22 of 32

# INT K/B

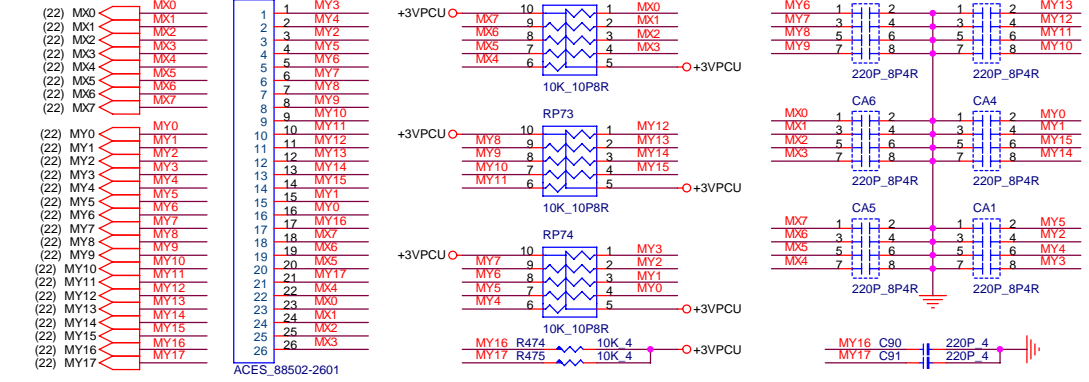

# TP

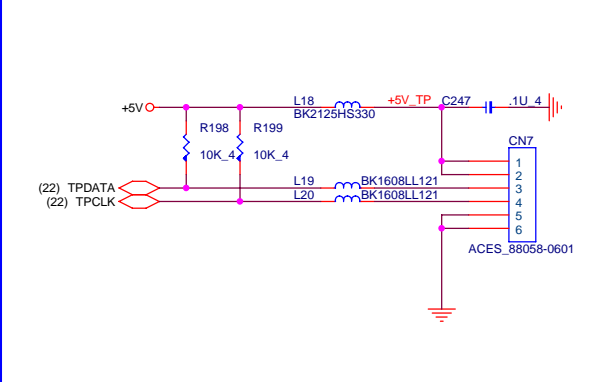

# SPEAKER LED

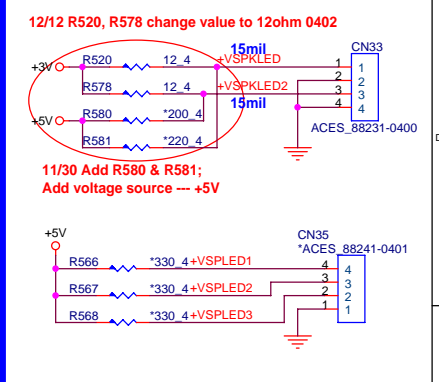

# CPU FAN

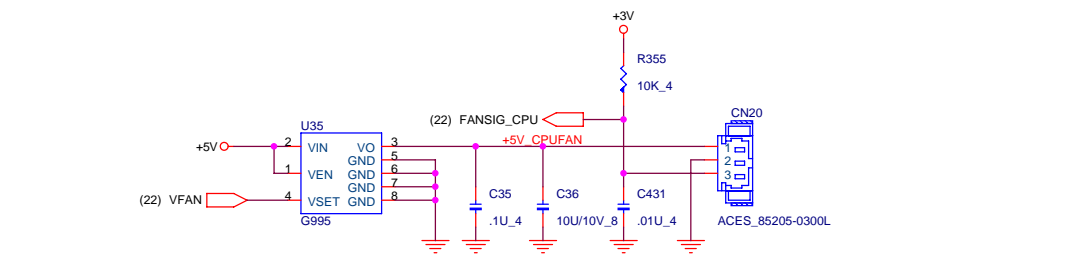

# 2ND FAN

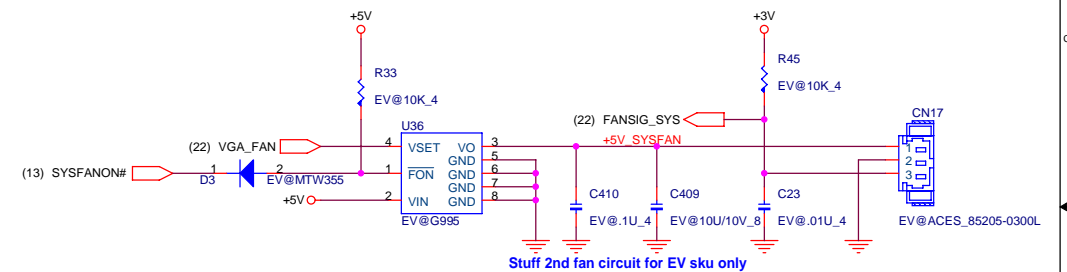

# LED

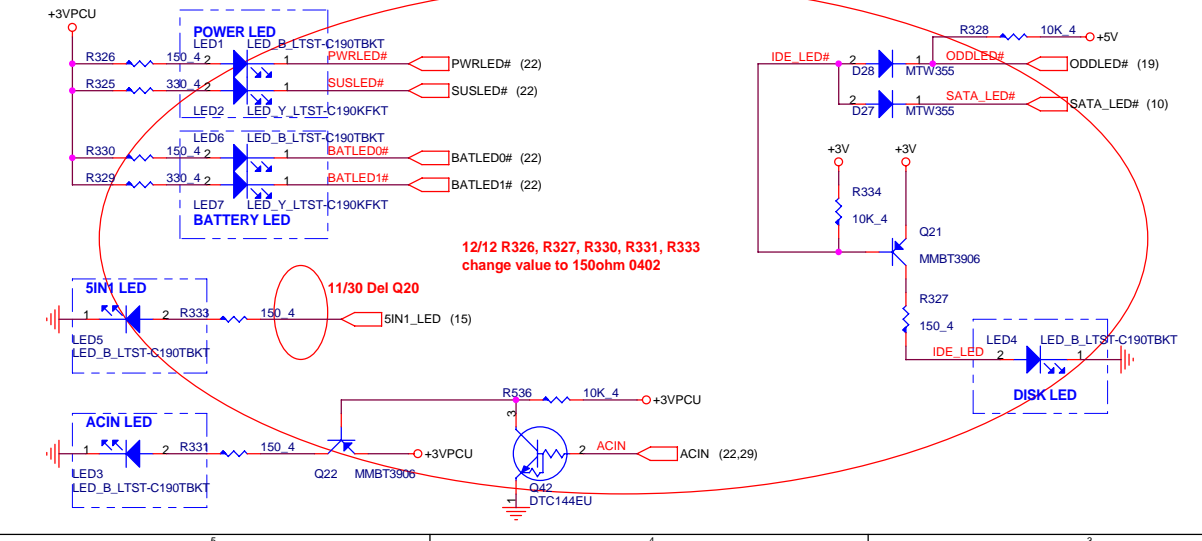

# BUTTON BOARD

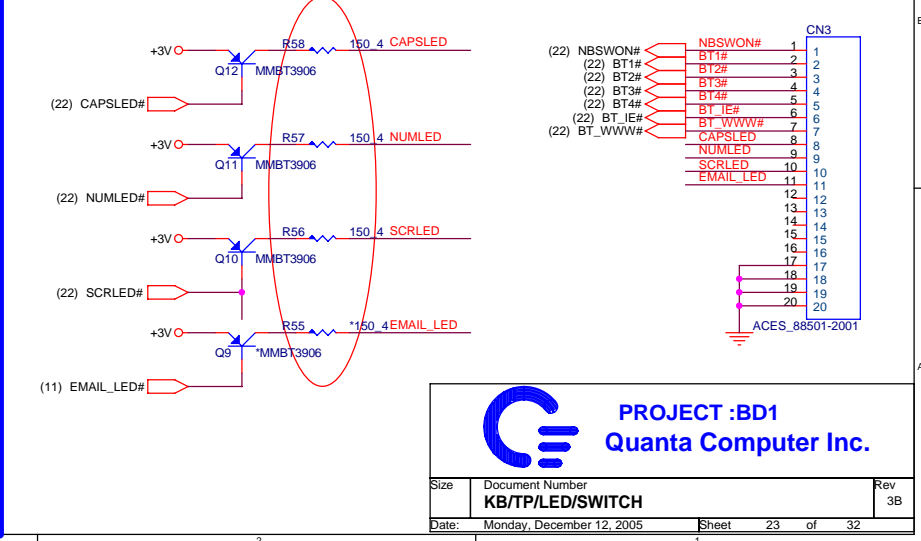





## PROJECT :BD1

### Quanta Computer Inc.

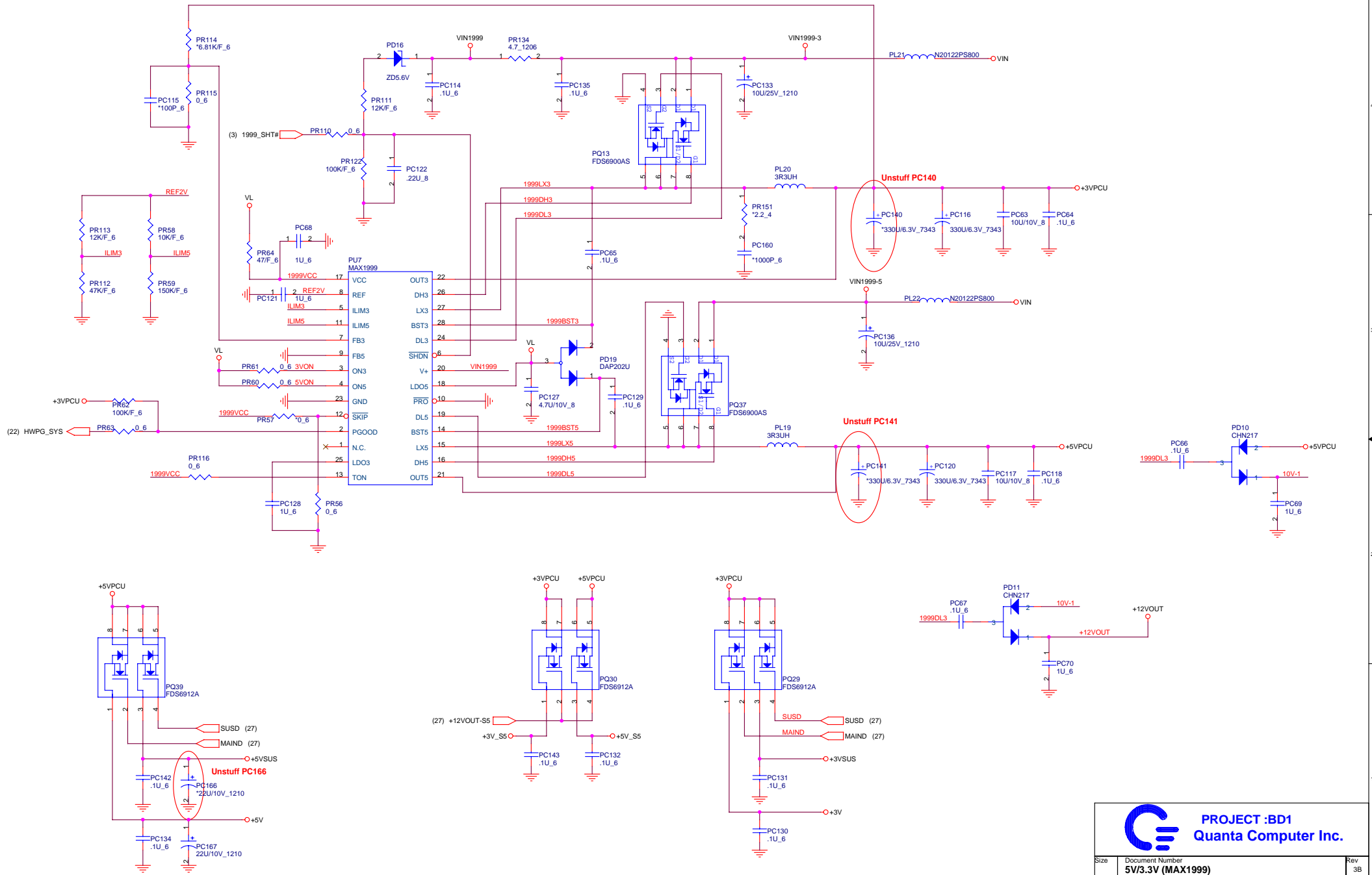
Size	Document Number	Rev
	<b>KB/TP/LED/SWITCH</b>	3B
Date:	Monday, December 12, 2005	Sheet 23 of 32





**PROJECT :BD1**  
**Quanta Computer Inc.**

Size	Document Number	Rev
5V/3.3V (MAX1999)	5V/3.3V (MAX1999)	3B
Date:	Monday, December 12, 2005	Sheet 24 of 32



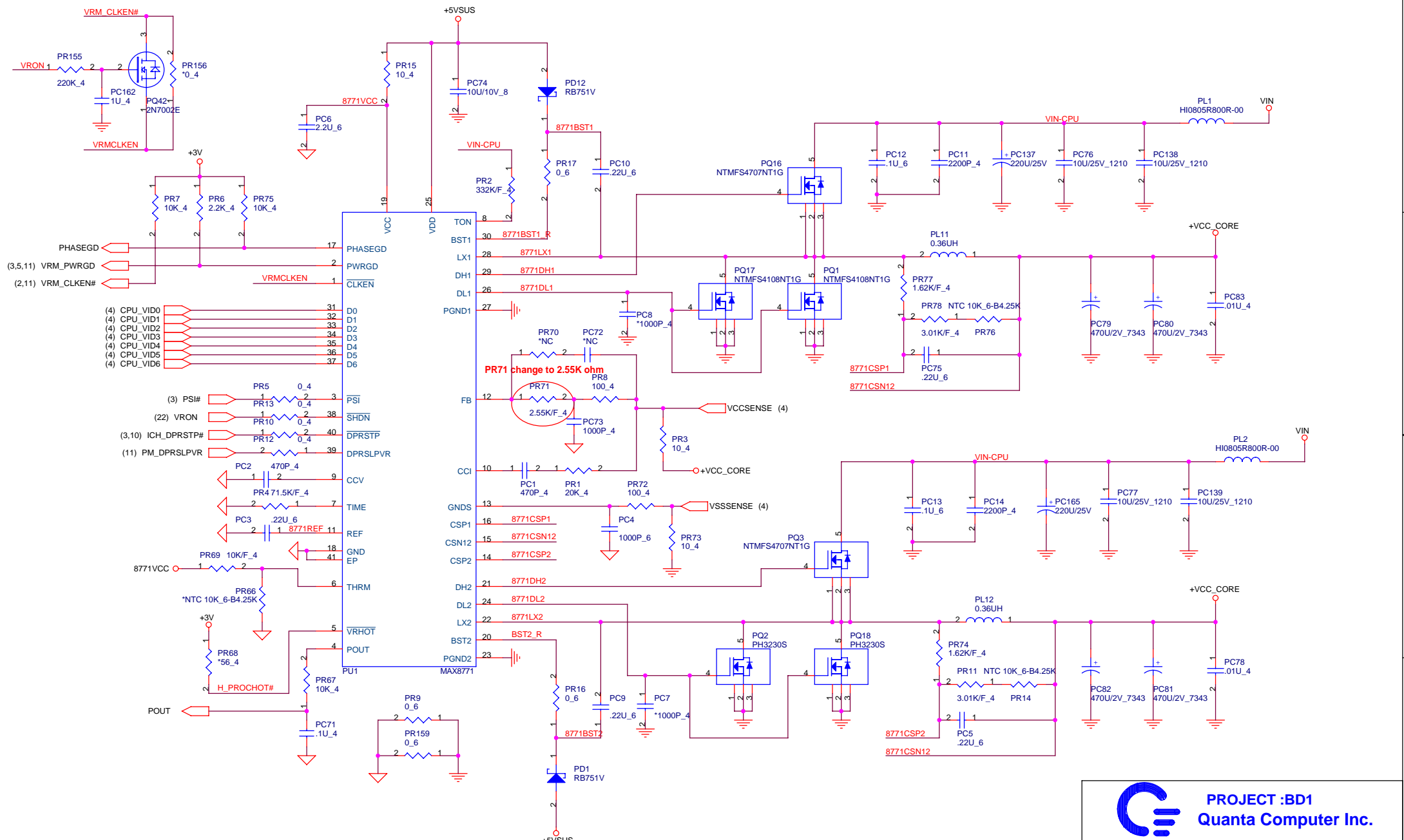

**PROJECT :BD1**  
**Quanta Computer Inc.**

Size	Document Number	Rev
	CPU CORE (MAX8771)	3B
Date:	Monday, December 12, 2005	Sheet 25 of 32

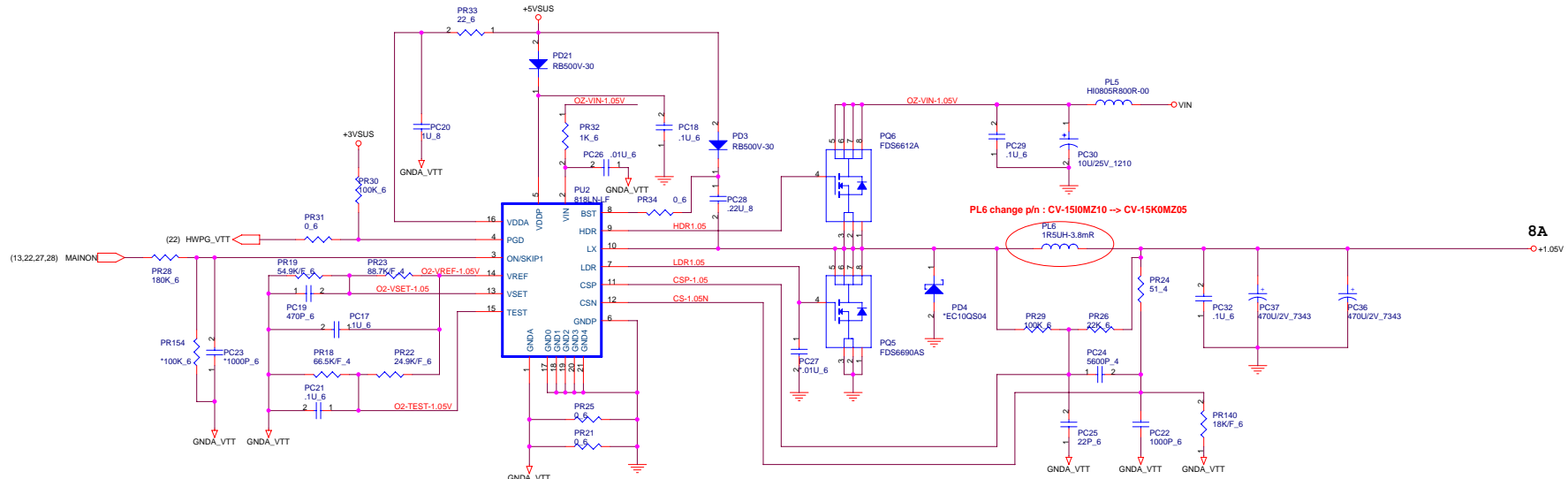

**DDR**

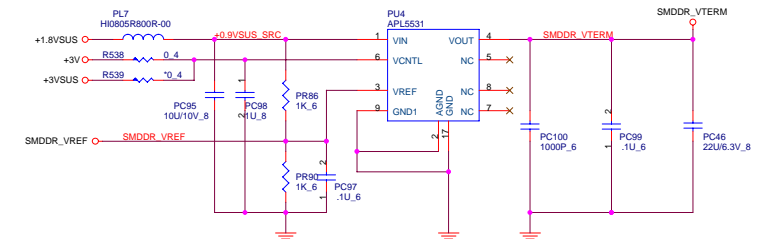
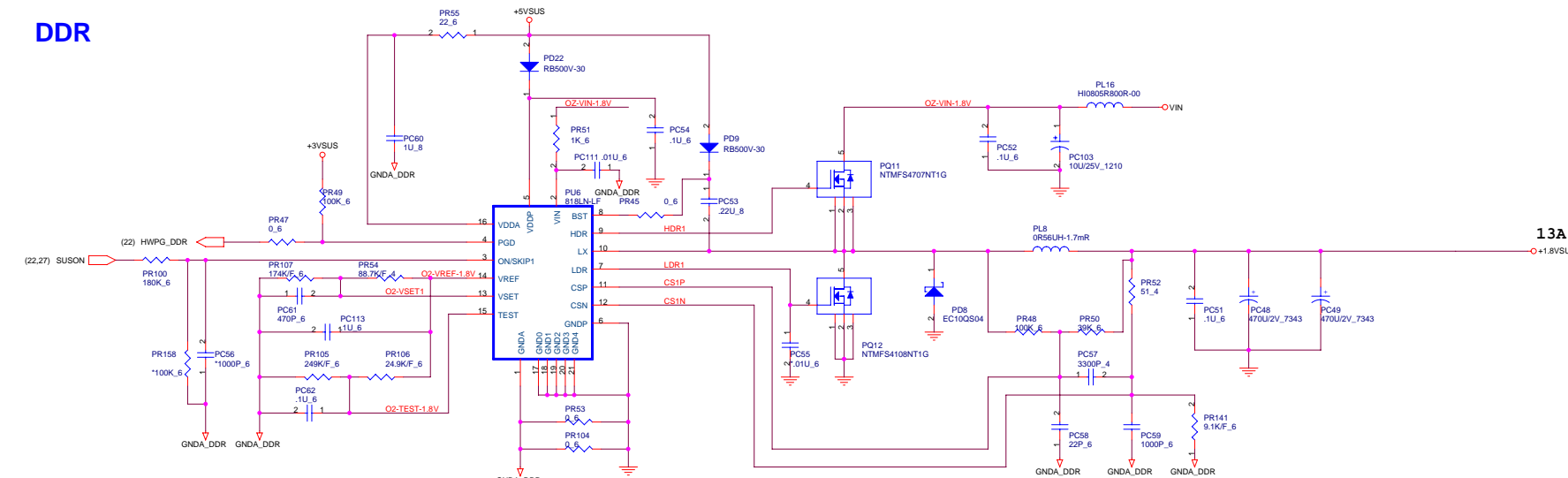

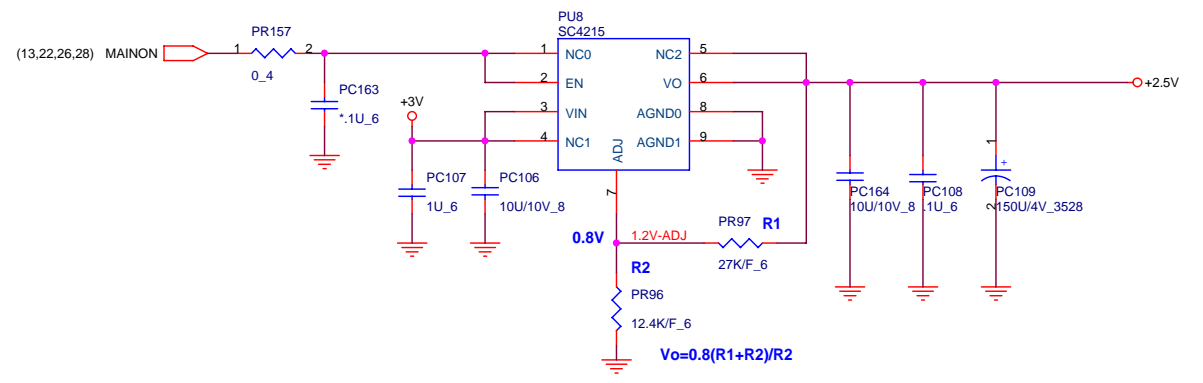
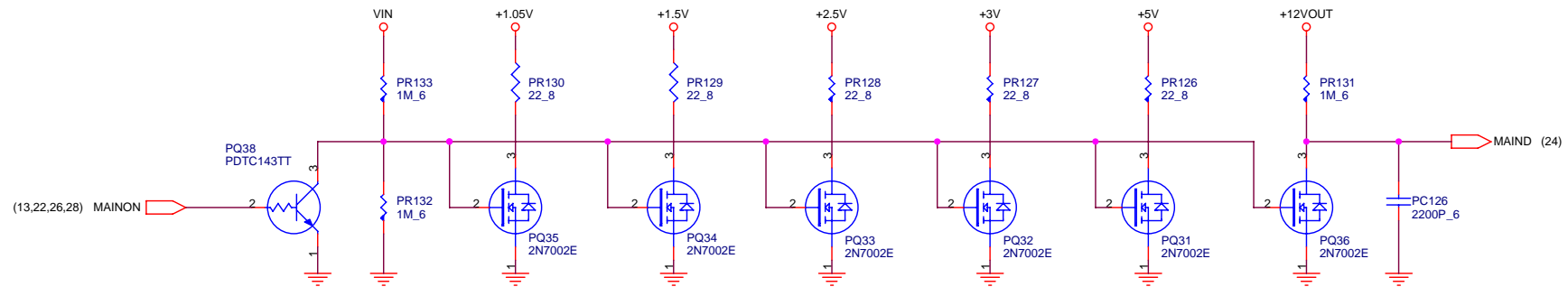
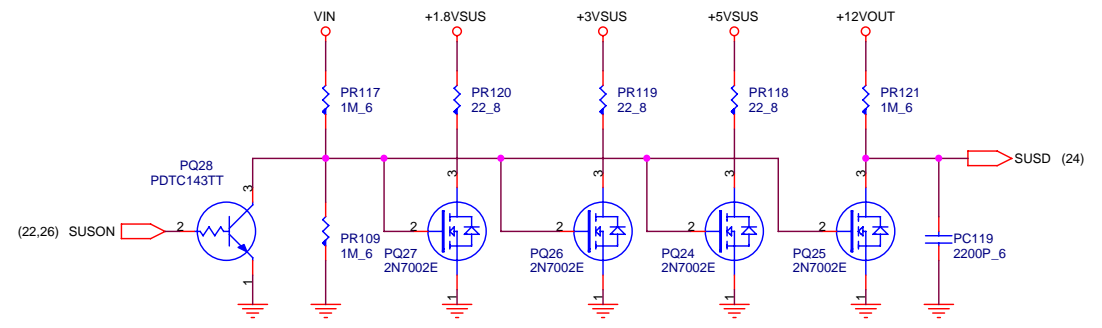
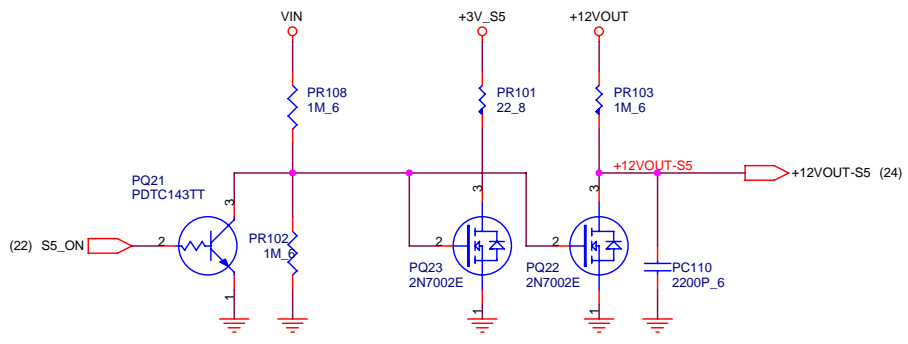



**PROJECT :BD1**  
**Quanta Computer Inc.**

Size	Document Number	Rev
	<b>2.5V/DISCHARGE</b>	3B
Date:	Monday, December 12, 2005	Sheet 27 of 32

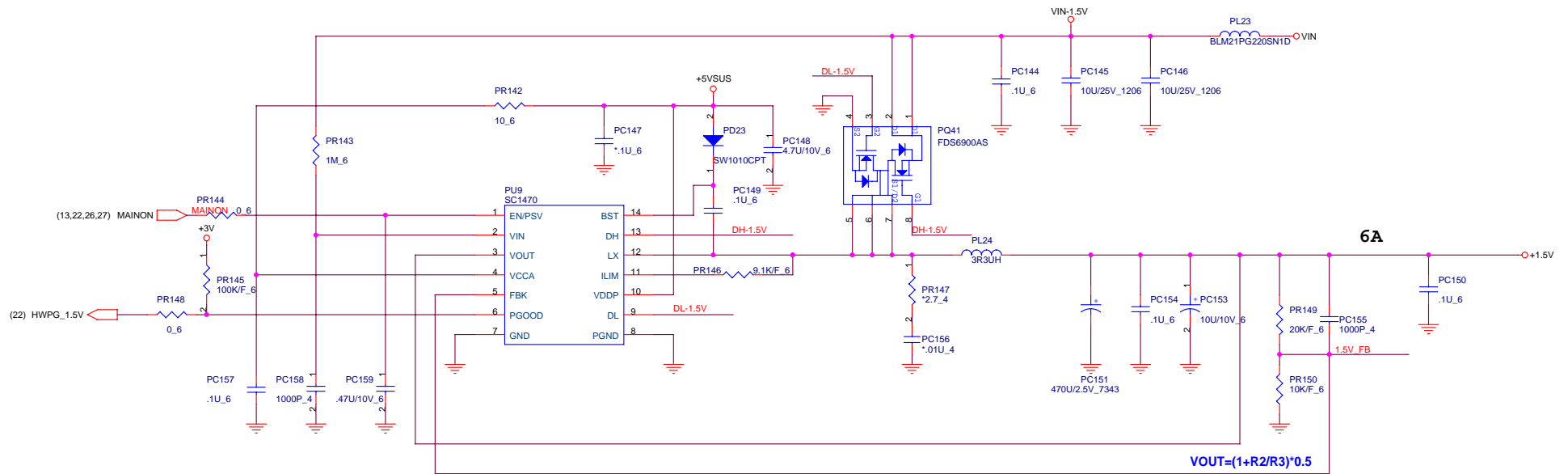

PROJECT :BD1  
Quanta Computer Inc.

Size	Document Number	Rev
	<b>+1.5V</b>	3B
Date:	Monday, December 12, 2005	Sheet 28 of 32

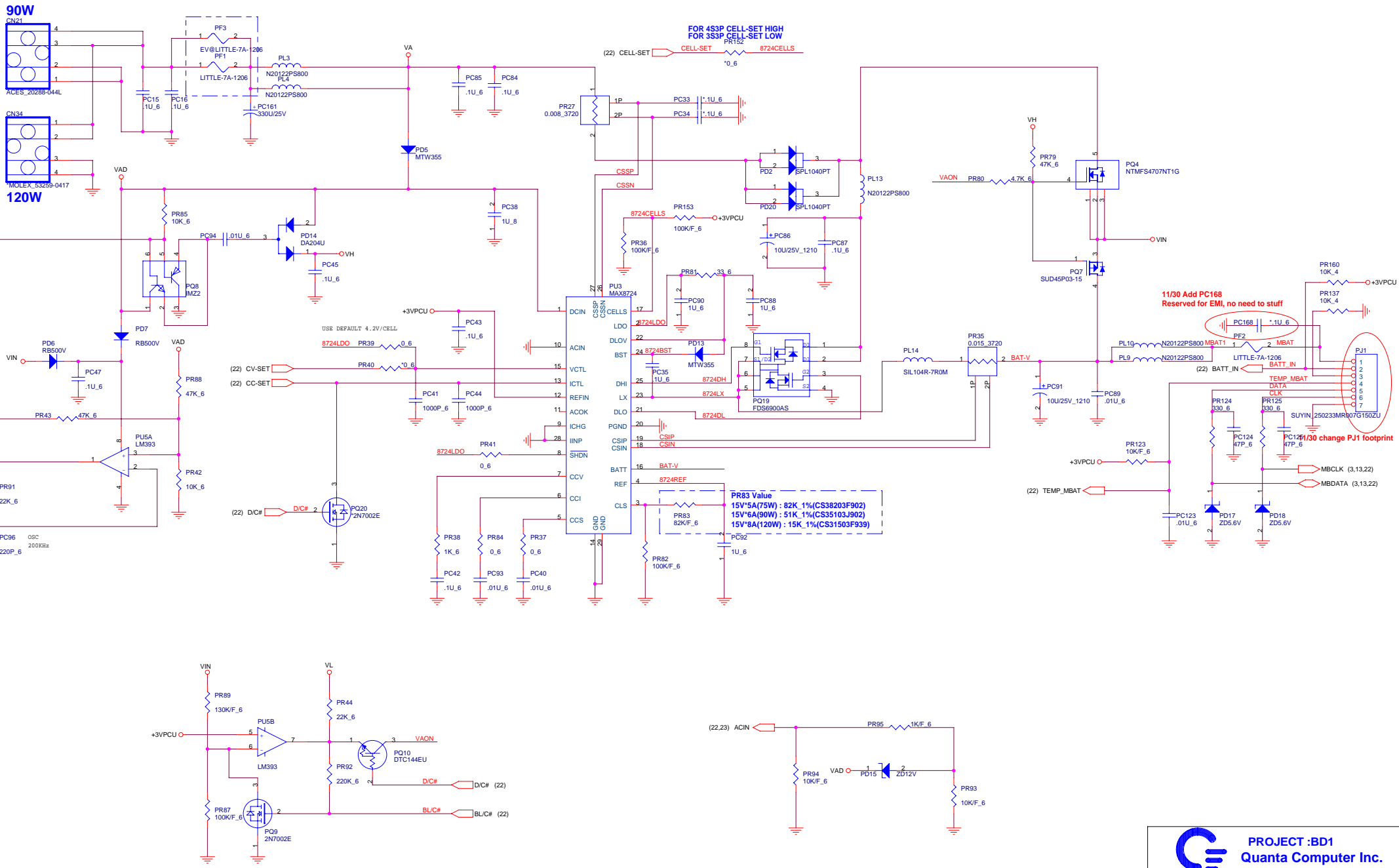

MODEL:	REV:	CHANGE LIST:	MODEL : BD1 MB		
BD1 MotherBoard	1A	FIRST RELEASE	PAGE	FROM	TO
	2A	<p>Page2. Stuff R136, R427, R432; Unstuff R116, R390, R428, R429, R433, R434</p> <p>Page3. U22 change P/N : AL001032048 --&gt; AL001032030; U21 change P/N : DGG^9000403 --&gt; DGG^9000055; R89 change value : 0ohm --&gt; 330ohm; R103 change value : 330ohm --&gt; 8.2Kohm; Delete R441; Add C625, Q38, Q39, Q40, Q41, R529, R530, R531, R532, R535, R533, R534</p> <p>Page5. Stuff R162 for external vga to reverse the PCIE lane</p> <p>Page8. C257 change p/n : CH72201M881 --&gt; CH7221M8854</p> <p>Page10. U5 change P/N : AKE3D8AKA09 --&gt; AKE3D8AKA17; Change C259, C260 stuff for GE sku only; Stuff R214, R455</p> <p>Page11. Add R506 ~ R513, R517, T140 ~ T143; Delete T34, T58, T63</p> <p>Change net : U25.AF19 : MBID1 --&gt; GPIO21; U25.AH18 : MBID0 --&gt; GPIO19; U25.F19 : GPIO12 --&gt; EMAIL_LED#; U25.R4 : GPIO14 --&gt; LID591#; U25.R3 : LAN_DISABLE# --&gt; MBID0; U25.D20 : GPIO25 --&gt; MBID1; U25.AD21 : LID591# --&gt; GPIO35; U25.AE20 : EMAIL_LED# --&gt; GPIO39; U25.B21 : MBID2 --&gt; GPIO27; U25.A21 : GPIO26 --&gt; MBID2; R155.1 : GPIO14 --&gt; LID591#</p> <p>Page12. Delete R127; Add D30; Change net : +3VSUS --&gt; +3V_S5; C248 change p/n : CH72201M881 --&gt; CH7221M8854</p> <p>Page13. C512, C513, C519, C524 change footprint : CC0805 --&gt; CC0603; Unstuff C515; CN22 change footprint : SPS2F-D-SMX-20-X-X-20P-LUV --&gt; 200109MA020G2612R-20P-LUV</p> <p>Page14. Delete SW1; Add R518, R519, C602, C603; C20, C32 change footprint to CC0603; CN11 change footprint : SV-030105FR004T101XX-4P-EW3 --&gt; SV-030018FR004S100FR-RVS-4P-V</p> <p>Page15. CN31 change footprint : 4IN1-R012-312-LR-44P --&gt; 4IN1-R102-316-XX-44P; U32 change p/n : AJ074120T13 --&gt; AJ084120T08</p> <p>Page16. R490, R492 change value : 10Kohm --&gt; 0ohm; CN9 change footprint : PCI-1CA4A5G1-TC2-LN-84P --&gt; PCI-1CA4A501-TC-RD-84P</p> <p>Page17. U20.M13, U20.N14 net swap; Add R515, R516, R521 ~ R526, R537, C624; Delete T2, T79; Stuff R375; Unstuff R59, R374, R378; U19 change p/n : AKE3C8W0601; U19 change footprint : SOIC8-6-1_27 --&gt; SOIC8-7_9-1_27</p> <p>Page18. Add T147, Delete C28, Q6, R262; Stuff L35, L36; Unstuff R7, R15, R16, R21, R30, R338; R48 change value : 100Kohm --&gt; 0ohm; R50 change value : 1Kohm --&gt; 10Kohm; CN15 change footprint : USB020173MR004SX07ZX-4P-V --&gt; USB-020173MR004G552ZR-4P-R-H; CN29 change footprint : NCARD-1CX43201-LN-RVS-26P --&gt; EXPRESSCARD-1CX43202-BD-26P; CN1.1 change net : BT_POWER --&gt; +3V</p> <p>Page19. Add C581 ~ C601, C604 ~ C623; Add HOLE33, PAD1 ~ PAD3; Delete HOLE2, HOLE16, HOLE19, HOLE32; HOLE7, HOLE8, HOLE11, HOLE15, HOLE18 change p/n : MBEW3001012 --&gt; MBBD1009016; CN26 change p/n : DFHS50FR393 --&gt; DFHS50FR369</p> <p>Page20. U15 change P/N : AL1G0086005 --&gt; AL1G0086013; C356, C361, C363, C388, C389, C397, C398, C399, C401, C402, C403, C405 change footprint to CC0603; Unstuff R303; Stuff R304; CN10 change pin define; Add Q36, Q37, R527, R528; CN32 change footprint : 88076-020XX-20P-RUV --&gt; 88241-20XX-20P-L; Change net (codec digital power) : +3V --&gt; +3VSUS; CN10 change p/n : DFWF04MS079 --&gt; DFHD04MR701; CN10 change pin define</p> <p>Change net : CN32.4 : IRRX2 --&gt; NC; CN32.6 : IRTX2 --&gt; BT_LED#; CN32.8 : IRMODE --&gt; LID591#; CODEC Power : +3V --&gt; +3VSUS</p> <p>Page21. Add T144 ~ T146; Unstuff R283, R287 and Stuff R280, R288 to change the SIO address to 162E</p> <p>Page22. Stuff C309, C310, C311, C322, D16, R241 ~ R244, R246, U30; Unstuff U29, C313; Add D31, D32, R514; Delete T73, T76</p> <p>Change net : U9.24 change net : LPCPD# --&gt; BT_IE#; U9.25 change net : CLKRUN# --&gt; BT_WWW#; U9.153 change net : BT_IE# --&gt; BT_LED#; U9.154 change net : BT_WWW# --&gt; NC; U9.156 change net to LAN_DISABLE#</p> <p>Page23. Add CN33, LED6, LED7, Q42, R520, R536; Delete Q23, R332; Q20, Q21 change to MMBT3904; Q22 change to MMBT3906; CN7 change p/n : DFHD06MS618 --&gt; DFFC06FR212; +3V change to +3VPCU; LED1, LED2 change package; LED3 change p/n : BEAB0006Z07 --&gt; BEGR0080Z07</p> <p>Page24. PQ30, PQ39 change p/n to BAM76520001</p> <p>Page25. PC11, PC14 change P/N : CH2226K1B16 --&gt; CH22206KB16; Stuff PD1, PD12, PQ2, PQ17; Unstuff PR68; PR2.1 change net to VIN-CPU; PL11, PL12 change P/N : CV+60V0MZ33 --&gt; DC+60Q0L001; PL11, PL12 change P/N : CV+60V0MZ33 --&gt; DC+60Q0L001</p> <p>Page26. Add PR135, PR136, R538, R539; PQ6, PQ11 change p/n to BAM76520001; PC24 change value : 4700P --&gt; 5600P; PR26 change value : 62K --&gt; 22K; PR50 change value : 100K --&gt; 39K</p> <p>Page27. PR96 change value : 306_1% --&gt; 604_1%; PR98 change value : 190_1% --&gt; 180_1%</p> <p>Page28. Add CN34, PD20, PF3, PR137; PR94 change value : 6.8K_1% --&gt; 10K_1%; PR95 change value : 10K_1% --&gt; 1K_1%; PR89.1, PD6.2 change net : REFP --&gt; VIN; PL14 change P/N : CV01044MZ18 --&gt; CV-6880MZ01; PQ4 change p/n to BAM76520001; CN21 change footprint</p>	1	2B	3A
	2	2B	3A		
	3	2B	3A		
	4	2B	3A		
	5	2B	3A		
	6	2B	3A		
	7	2B	3A		
	8	2B	3A		
	9	2B	3A		
	10	2B	3A		
	11	2B	3A		
	12	2B	3A		
	13	2B	3A		
	14	2B	3A		
	15	2B	3A		
	16	2B	3A		
	17	2B	3A		
	18	2B	3A		
	19	2B	3A		
	20	2B	3A		
	21	2B	3A		
	22	2B	3A		
	23	2B	3A		
	24	2B	3A		
	25	2B	3A		
	26	2B	3A		
	27	2B	3A		
	28	2B	3A		
29	2B	3A			

		PROJECT : BD1	APPROVE BY: SAINT LIN	DRAWING BY:DILBERT YU	REV 3B	COVER SHEET 1/3
Size	Document Number	Rev	MB ASSY'S P/N : 31BD1MBXXXX	PROJECT LEADER: SAINT LIN	DOCUMENT NO:	
Change List --- 1		3B				
Date:	Monday, December 12, 2005	Sheet	30	of	32	

MODEL:	REV:	CHANGE LIST:	MODEL : BD1 MB		
BD1 MotherBoard	2B	<p>Page2. Add R540; Stuff R124, R125, RP18 for GE sku only; Stuff R423 and Unstuff R413, R414, R415 for all sku</p> <p>Page3. Thermal sensor power change net : +3V --&gt; +3VSUS; Add Q43, R565 for Thermaltrip circuit; Delete Q30, R386; Unstuff R384</p> <p>Page4. R104, R106, R111 change footprint : RC0402 --&gt; RC0603</p> <p>Page7. R404 change value : 150_1% --&gt; 75_1%</p> <p>Page8. Delete R233, R424, R452; L22 change p/n : CV+1003JN27 --&gt; CVA9115MN10; R459 change footprint : RC0805 --&gt; RC1206; Add C640, R552 ~ R557 to separate the PM &amp; GM power state</p> <p>Page9. CN24 change net : PM_EXTT3#1 --&gt; PM_EXTT3#0; PR231, PR232, PR234 change footprint : RC0402 --&gt; RC0603</p> <p>Page10. RT4 change power change net : +5VSUS --&gt; +5VPCU; Delete RP31; Add R547 ~ R549</p> <p>Page11. U25,AA4 change net : CH_PWROK --&gt; PWROK_EC; Delete C471, D12, R142, R144, R391, R397, U23 to simplify the power ok circuit; Stuff R442 for GE sku; Stuff R445 for FE sku;</p> <p>Add C626, R544, R545, R550, R558 ~ R561; Delete T37, T41, T50, T51, T60, T115, T140, T141</p> <p>Page12. Add L54, L55 to separate the lan power for FE &amp; GE; Change net : +5VSUS --&gt; +5V_S5; Add R551; Delete D30 to change the 5VREFSUS power</p> <p>Page13. Add C627 ~ C634 for EMI reserved; CN22 change p/n : DFHS20FS496 --&gt; DFHD10MSA93; CN27.118 : LVDS_BLON --&gt; EV_BLON; CN27.120 : DISP_ON --&gt; EV_PNLON</p> <p>Page17. Stuff R377, Unstuff C455, C457, C459, L40, Q29, R376 to change the LAN 2.5V power source to chip internal LDO; Add L56, L57 for EMI reserved;</p> <p>C432, C433 change value : 22P --&gt; 33P; U19 change footprint</p> <p>Page18. Change net : BT_PWROK# --&gt; BT_RESET#; CN1 change p/n : DFFC20FR115 --&gt; DFFC20FR204; CN4.(8,9) change net : USBOC#2 --&gt; NC; U1.(5,8) change net : USBOC#0 --&gt; NC;</p> <p>CN29 change p/n : DFHD26MR040 --&gt; DFHD26MR180; L35, L36 change p/n : DC09004A014 --&gt; CX201290009; Delete R7</p> <p>Page19. C424, C425 change value : 4.7U --&gt; 22U; Add C642; Delete HOLE13; HOLE27, HOLE28 change p/n : MBBD1007013 --&gt; MBBD1011011; Add C635 ~ C639, PAD4 ~ PAD9 for EMI reserved</p> <p>Page20. C379, C382 change value : 1U --&gt; 10U; Stuff R319, Unstuff C382 to change to mono mic function; Unstuff Q37, R528; Unstuff D25, Add C641, D33, R562, R563, R564, U37 to change the mute method for preventing the pop noise; CN28 change p/n : DFHS10FS476 --&gt; DFHD12MS621; Stuff U14; Unstuff R296</p> <p>Page21. Unstuff D22; C343, C348 change value : 12P --&gt; 22P</p> <p>Page22. Stuff D18, Unstuff D15 change the power ok circuit; Change net : BT_PWROK# --&gt; BT_RESET#; Add R541; Delete C313, U29, T75</p> <p>Page23. R520 change value : 150 --&gt; 100; Add R566 ~ R568, CN35 for speaker led function; Add U35, U36, Delete D8, Q3, Q7, Q8, Q26, R32, R53, R54 to change the fan control method</p> <p>Page24. Add PR151, PC160 for EMI reserved; PQ13, PQ37 change p/n : BAM49140023 --&gt; BAM69000031; PQ39 change p/n : BAM76520001 --&gt; BAM44180001; PQ30 change p/n : BAM76520001 --&gt; BAM69120001; PQ29 change p/n : BAM48040017 --&gt; BAM69120001; Add PC140 ~ PC143, PQ40; Delete PQ14, PQ15, PR65</p> <p>Page25. PQ3, PQ16 change p/n : BAM70300Z06 --&gt; BAM47070001; PQ1, PQ2, PQ17, PQ18 change p/n : BAM32300Z02 --&gt; BAM41080005; PR2 change value : 200K_1% --&gt; 332K_1%; PR11, PR78 change value : 5.11K_1% --&gt; 3.01K_1%; PR71 change value : 3.48K_1% --&gt; 2.55K_1%; PR74, PR77 change value : 2.94K_1% --&gt; 1.62K_1%; PC73 change value : 4700P --&gt; 1000P; PC79 ~ PC82 change p/n : CH747LM8801 --&gt; CH747RY8800; PL11, PL12 change p/n : DC+60Q0L001 --&gt; CV+18V0MZ04; Add PC137 ~ PC139, PC162, PQ42, PR155, PR156, PR159</p> <p>Page26. PC46 change value : 10U --&gt; 22U; PR28, PR100 change value : 100K --&gt; 180K; Add PD21, PD22, PR140, PR141, PR154, PR158; Delete PC31, PC50, PR20, PR46, PR135, PR136; Stuff PD4, PD8; Unstuff PC23, PC56; PL6 change p/n : CV-33D5MZ04 --&gt; CV-15I0MZ10; PL8 change p/n : CV-15I0MZ10 --&gt; CV+56F0MZ01; PQ5 change p/n : BAM28030Z12 --&gt; BAM66900022; PQ6 change p/n : BAM76520001 --&gt; BAM66120027; PQ11 change p/n : BAM70300Z06 --&gt; BAM47070001; PQ12 change p/n : BAM70300Z06 --&gt; BAM41080005; PC19, PC61 change value : 1000P --&gt; 470P; PC20, PC60 change value : 10U --&gt; 1U; PC26, PC111 change value : .1U --&gt; .01U; PC36, PC37, PC48, PC49 change value : 150U --&gt; 470U; PR22, PR106 change value : 2.55K_1% --&gt; 24.9K_1%; PR18 change value : 24.9K_1% --&gt; 66.5K_1%; PR105 change value : 24.9K_1% --&gt; 249K_1%</p> <p>Page27. Delete JP5, JP6, PC101, PC102, PC104, PC105, PC112, PL17, PL18, PR98, PR99, PU9, PU10 to remove the +1.5V LDO power source; Add PC163, PC164, PR157; Delete PL15; PC108 change value : 1000P --&gt; 0.1U to adjust the +2.5V power source</p> <p>Page28. Add +1.5V PWM power circuit</p> <p>Page29. Add PC161; Add PR152; PD2, PD20 change p/n : BCBSM104Z01 --&gt; BCPL1040Z18; PQ4 change p/n : BAM76520001 --&gt; BAM47070001; PQ7 change p/n : BAM48350024 --&gt; BAM45030Z09; Add PR153; PR36 change value : 0 --&gt; 100K/F_6; PQ19 change p/n : BAM49140023 --&gt; BAM69000031; PL14 change p/n : CV-6880MZ01 --&gt; CV-7048MZ01</p>	PAGE	FROM	TO
		1	2B	3A	
		2	2B	3A	
		3	2B	3A	
		4	2B	3A	
		5	2B	3A	
		6	2B	3A	
		7	2B	3A	
		8	2B	3A	
		9	2B	3A	
		10	2B	3A	
		11	2B	3A	
		12	2B	3A	
		13	2B	3A	
		14	2B	3A	
		15	2B	3A	
		16	2B	3A	
		17	2B	3A	
		18	2B	3A	
		19	2B	3A	
		20	2B	3A	
		21	2B	3A	
		22	2B	3A	
		23	2B	3A	
		24	2B	3A	
		25	2B	3A	
		26	2B	3A	
		27	2B	3A	
		28	2B	3A	
29	2B	3A			
3A	<p>Page3. Stuff Q43, Unstuff C625,R565 for thermaltrip# function</p> <p>Page12. C505 change footprint : CC7343 --&gt; CC3528, change value : 330U --&gt; 150U; Add C643</p> <p>Page14. Add R569 for DVI hot plug detection; Add R572, R573</p> <p>Page15. CN25 change footprint : 1394-020115FB004S500ZL-4P-H --&gt; 1394-020015FR004S513ZL-RVS-4P-H, change p/n : DFHD04MR647 --&gt; DFDS04FR051</p> <p>Page17. Delete R78, Add D35 for GigaLan disable function</p> <p>Page18. Add R574 ~ R577 ; C325,C326,C550,C551 change to 0 ohm</p> <p>Page19. PAD6 delete the GND net and add plate , C411 change to 330U</p> <p>Page20. CN32 change p/n : DFFC20FR115 --&gt; DFFC20FR212</p> <p>Page21. Add Q44, R571 for CIR wakeup function</p> <p>Page22. Add R570 for lid wakeup function; Add D34</p> <p>Page23. CN3 change p/n : DFFC20FR115 --&gt; DFFC20FR212</p> <p>Page24. PD10, PD11 change footprint : SOT23 --&gt; UMT ; PC166,PC167 change to 22U</p> <p>Page25. PR155 change value : 1K --&gt; 220K; PC162 change value : 0.1U --&gt; 1U; PC137 change value : 470U --&gt; 220U; Add PC165</p> <p>Page26. Unstuff PD4; Delete JP1, JP2, JP3, JP4</p> <p>Page27. Delete JP7</p> <p>Page28. Delete JP9, JP10; PR146 change value : 18K_1% --&gt; 9.1K_1%; PC151 change value : 470U/2V --&gt; 470U/2.5V</p> <p>Page29. PJ1 change p/n : DFHD07MR641 --&gt; DFHD07MR675</p>				

		PROJECT : BD1	APPROVE BY: SAINT LIN	DRAWING BY:DILBERT YU	REV 3B	COVER SHEET 2/3
Size	Document Number	Rev	MB ASSY'S P/N : 31BD1MBXXXX	PROJECT LEADER: SAINT LIN	DOCUMENT NO:	
Change List -- 2		3B				
Date: Monday, December 12, 2005		Sheet 31 of 32				

MODEL:	REV:	CHANGE LIST:	MODEL : BD1 MB		
BD1 MotherBoard	3B	<p>Page2. Add C647~C653 to reserve.</p> <p>Page8. L14 package change to RC0805.</p> <p>Page15. Add R582 for TI-7412, in TI-7412 Pin-G6 is +3V power.</p> <p>Page19. Add PAD10~PAD12 for EMI.</p> <p>Page20. Del Q37,R528 --- not use.            Net name change to Kill_LED from BT_LED            Net name change to Kill_LED# from BT_LED#.</p> <p>Page23. Del Q20 for 5IN1 LED.            Add R580 and R581to support speaker voltage source can be change to +5V.            R520 and R578 change to 12ohm for speaker current ( 9~10mA ).</p> <p>Page29. Add PC168 for EMI            change Battery connector for 100W.</p>	PAGE	FROM	TO
			1	3A	3B
			2	3A	3B
			3	3A	3B
			4	3A	3B
			5	3A	3B
			6	3A	3B
			7	3A	3B
			8	3A	3B
			9	3A	3B
			10	3A	3B
			11	3A	3B
			12	3A	3B
			13	3A	3B
			14	3A	3B
			15	3A	3B
			16	3A	3B
			17	3A	3B
			18	3A	3B
			19	3A	3B
			20	3A	3B
			21	3A	3B
			22	3A	3B
			23	3A	3B
			24	3A	3B
			25	3A	3B
			26	3A	3B
			27	3A	3B
			28	3A	3B
29	3A	3B			



**Quanta Computer Inc.**

Size Document Number Rev  
**Change List --- 3** 3B

Date: Monday, December 12, 2005 Sheet 32 of 32

PROJECT : BD1	APPROVE BY: SAINT LIN	DRAWING BY:DILBERT YU	REV 3B	COVER SHEET 3/3
MB ASSY'S P/N : 31BD1MBXXXX	PROJECT LEADER: SAINT LIN	DOCUMENT NO:	DATE :2005/12/02	