

SAMSUNG PROPRIETARY

THIS DOCUMENT CONTAINS CONFIDENTIAL
PROPRIETARY INFORMATION THAT IS
SAMSUNG ELECTRONICS CO.'S PROPERTY.
DO NOT DISCLOSE TO OR DUPLICATE FOR OTHERS
EXCEPT AS AUTHORIZED BY SAMSUNG.

Lampard-AMD INT

CPU : AMD ZACATE
Chip Set : FCH(Hudson-M3L)
Remarks : Brazos2.0 Platform

Model Name : Lampard-AMD
PBA Name : MAIN
PCB Code : BA41-XXXXXX (PTC)
BA41-XXXXXX (HST)
BA41-XXXXXX (GCE)
Dev. Step : PR
Revision : 1.0
T.R. Date : 2013.01.23

Design	CHECK	APPROVAL
Zhou Pei	XIE BIN	BL LEE

Owner : SESC R & D Signature : X

- sheet01 : Cover
- sheet02 : BLOCK DIAGRAM
- sheet03 : BOARD INFORMATION
- sheet04 : POWER DIAGRAM
- sheet05 : CLOCK DISTRIBUTION
- sheet06 : Green Clock
- sheet07 : Thermal Sensor
- sheet08 : CPU-ZACATE (1/3)
- sheet09 : CPU-ZACATE (2/3)
- sheet10 : CPU-ZACATE (3/3)
- sheet11 : DDR3 SODIMM1
- sheet12 : DDR3 SODIMM2
- sheet13 : PCH-A68M (1/5)
- sheet14 : PCH-A68M (2/5)
- sheet15 : PCH-A68M (3/5)
- sheet16 : PCH-A68M (4/5)
- sheet17 : PCH-A68M (5/5)
- sheet18 : LVDS/CAMERA
- sheet19 : VGA
- sheet20 : HDMI
- sheet21 : Audio - ALC269Q-VC-GR
- sheet22 : Audio - Combo Jack
- sheet23 : 3IN1/TPM
- sheet24 : LAN (Realtek RTL8105E)
- sheet25 : WLAN
- sheet26 : SATA interface (HDD/ODD I/F)
- sheet27 : MICOM / BIOS(MEC1310)
- sheet28 : MICOM Glue Logic
- sheet29 : USB3.0 connector
- sheet30 : MAIN TO SUB CONNECTOR
- sheet31 : Power - charger
- sheet32 : Power - P3.3V_AUX / P5.0V_ALW
- sheet33 : Power - P1.05V (Chipset Power)
- sheet34 : Power - P1.1V_AUX/P1.8V
- sheet35 : Power - DDR3
- sheet36 : Power - CPU VRM
- sheet37 : Power - Switched Power 1
- sheet38 : Power - Power Discharge
- sheet39 : Mount Hole
- sheet40 : SUB (TOUCHPAD)

DRAW	LI CHEN	DATE	08/03/2012	TITLE	Lampard-14/15-INT	SAMSUNG ELECTRONICS
CHECK	XIAO SUN	DEV.STEP	PV	MAIN	PART NO.	
APPROVAL	LEI GUO	REV	REV 1.0	COVER	BA41-*****A	
MODULE CODE		LAST EDIT	September 25, 2012 07:52:37 AM	PAGE	1 OF 42	

SAMSUNG PROPRIETARY
 THIS DOCUMENT CONTAINS CONFIDENTIAL
 PROPRIETARY INFORMATION THAT IS
 SAMSUNG ELECTRONICS CO.'S PROPERTY.
 DO NOT DISCLOSE TO OR DUPLICATE FOR OTHERS
 EXCEPT AS AUTHORIZED BY SAMSUNG.

BLOCK DIAGRAM

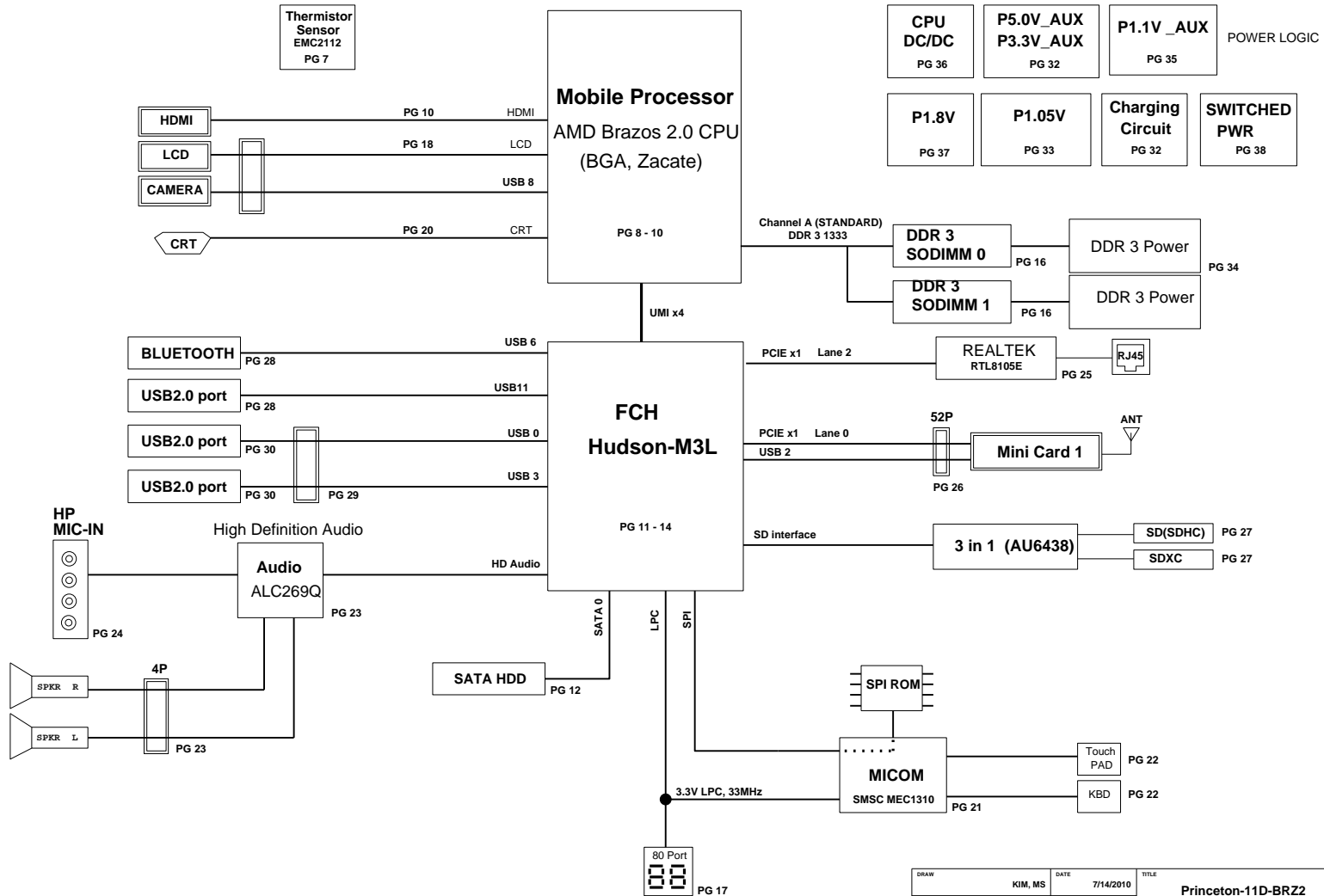

DRAW	KIM, MS	DATE	7/14/2010	TITLE	Princeton-11D-BRZ2 MAIN BLOCK DIAGRAM	SAMSUNG ELECTRONICS PART NO. BA41-####A
CHECK	PARK, CH	DEV. STEP	ADV1			
APPROVAL	CHO, KS	REV	REV 0.23			
MODULE CODE	undefined	LAST EDIT	February 28, 2012 13:33:37 PM			
PAGE 2 OF 40						

SAMSUNG PROPRIETARY

THIS DOCUMENT CONTAINS CONFIDENTIAL PROPRIETARY INFORMATION THAT IS SAMSUNG ELECTRONICS CO.'S PROPERTY. DO NOT DISCLOSE TO OR DUPLICATE FOR OTHERS EXCEPT AS AUTHORIZED BY SAMSUNG.

BOARD INFORMATION

SCHEMATIC ANNOTATIONS AND BOARD INFORMATION

Voltage Rails	Active in
VDC P3.3V_MICOM Primary DC system power supply (7 to 21V) 3.3V always power rail (for Micom)	S4 - S5
P5.0V_LDO 5.0V always power rail	
P5.0V_ALW 5.0V switched on power rail (off in S4-S5) P3.3V_AUX 3.3V switched on power rail (off in S4-S5) P1.1V_AUX 1.5V power rail for DDR3 (off in S4-S5)	S3
P5.0V 5.0V switched power rail (off in S3-S5) P3.3V 3.3V switched power rail (off in S3-S5) P1.8V 1.8V switched power rail (off in S3-S5) P0.75V 0.75V power rail for DDR3 (off in S3-S5) P1.1V 1.1V switched power rail (off in S3-S5)	S0
VCC_CORE Core Voltage for CPU EGFX_CORE Core Voltage for GPU P1.05V (VCCP) VCC for FCH	S0

Crystal / Oscillator			
TYPE	FREQUENCY	DEVICE	USAGE
Crystal	32.768KHz	FCH	Real Time Clock
Crystal	25MHz	LAN	REALTEK
Crystal	25MHz	FCH	
Crystal	27MHz	MARS	
Crystal	48MHz	SD	

LCD Pannel Detect (TBD)		
Devices	Resolution	PANNEL_DETECT_0

USB PORT Assign		PCI Express Assign	
PORT #	ASSIGNED TO	PORT #	ASSIGNED TO
0	SYSTEM PORT 0	1	Mini Card 1 (WLAN)
1	SYSTEM PORT 1	2	NC
2	Mini PCI Express (WLAN)	3	NC
3	SYSTEM PORT 2	4	LAN CONTROLLER
4	Multi Memory Card Controller	5	NC
5	Camera 1	6	NC
6	NC (N/A WITH FCH)	7	NC
7	NC (N/A WITH FCH)	8	NC
8	NC		
9	NC		
10	NC		
11	Camera 2		
12	NC		
13	NC		

I ² C / SMB Address			
Devices	Address	Hex	Bus
PANTHERPOINT	Master	-	SMBUS Master
CPU Thermal Sensor	0011 000X	30h	Thermal Sensor
SODIMM0	1010 000x	A0h	-
SODIMM1	1010 010x	A4h	-
Thermal Sensor on SODIMM0	0011 000x	30h	-
Thermal Sensor on SODIMM1	0011 010x	34h	-
on board DDR3 thermal Sensor	1001 100x	98h	-
Platform thermal management TS	1001 011x	96h	-

SATA PORT Assign	
PORT #	ASSIGNED TO
0	HDD/SSD
1	ISSD
2	ODD (14" ONLY)
3	
4	
5	

DRAW	LI CHEN	DATE	08/03/2012	TITLE	Lampard-14/15-INT MAIN BOARD INFO	SAMSUNG ELECTRONICS PART NO. BA41-*****A
CHECK	XIAO SUN	DEV. STEP	PV			
APPROVAL	LEI GUO	REV	REV 1.0			
MODULE CODE	undefined	LAST EDIT	September 25, 2012 07:52:37 AM	PAGE 3 OF 42		

SAMSUNG PROPRIETARY

THIS DOCUMENT CONTAINS CONFIDENTIAL PROPRIETARY INFORMATION THAT IS SAMSUNG ELECTRONICS CO.'S PROPERTY. DO NOT DISCLOSE TO OR DUPLICATE FOR OTHERS EXCEPT AS AUTHORIZED BY SAMSUNG.

POWER DIAGRAM

Rev 0.1

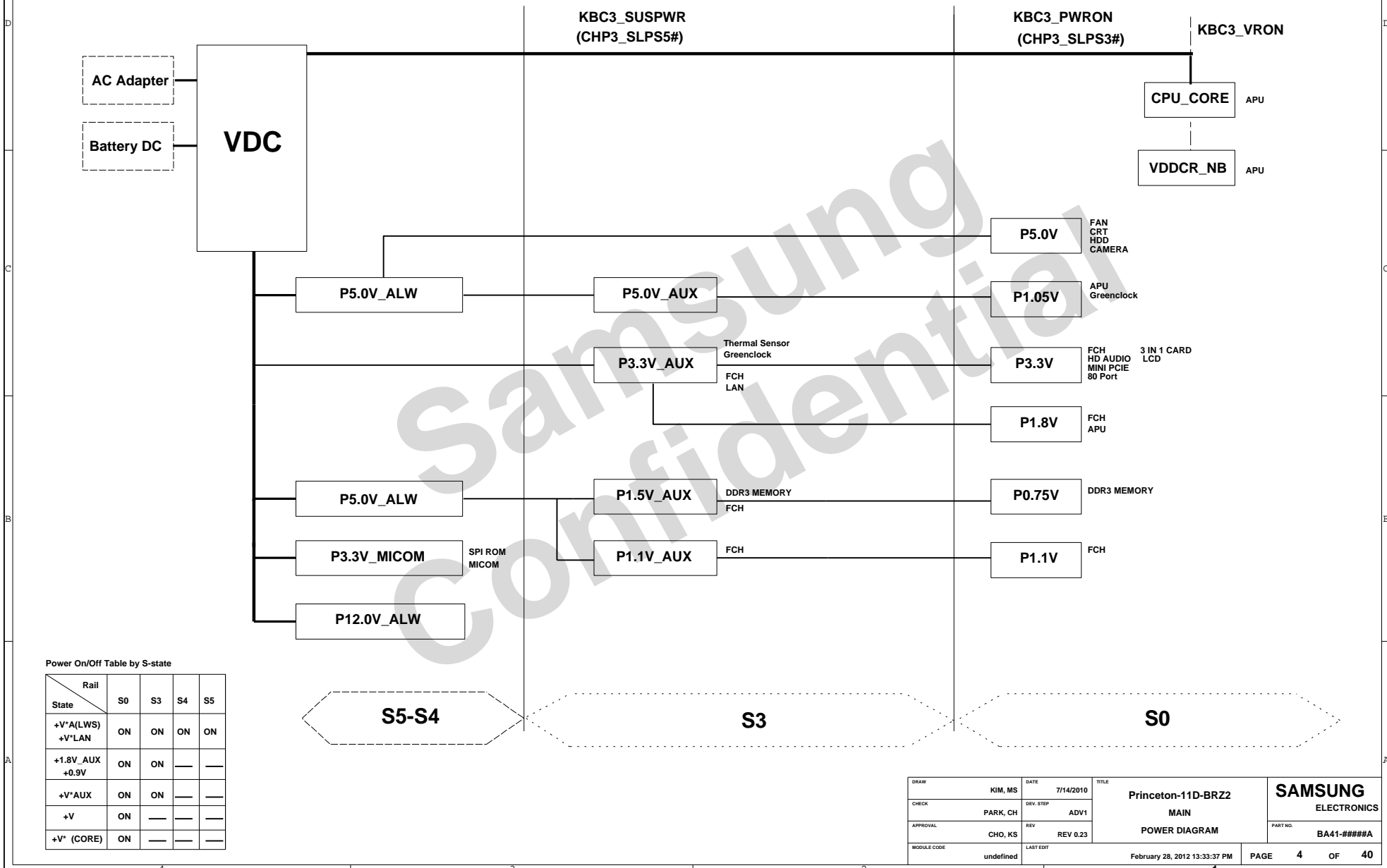

SAMSUNG PROPRIETARY

THIS DOCUMENT CONTAINS CONFIDENTIAL
PROPRIETARY INFORMATION THAT IS
SAMSUNG ELECTRONICS CO.'S PROPERTY.
DO NOT DISCLOSE TO OR DUPLICATE FOR OTHERS
EXCEPT AS AUTHORIZED BY SAMSUNG.

CLOCK DISTRIBUTION Rev. 1.0
INTEGRATED CLOCK MODE

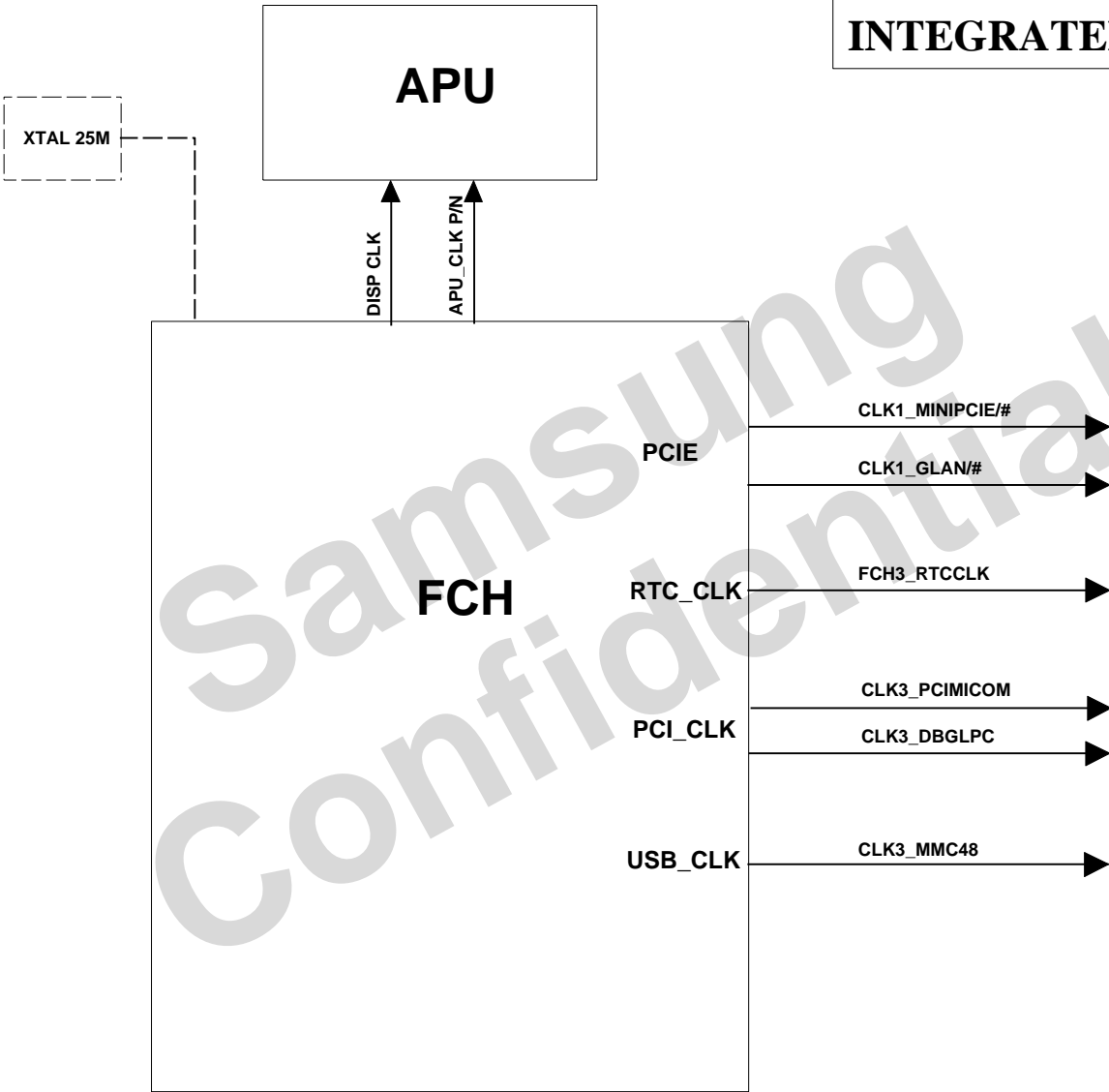

DRAW	KIM, MS	DATE	7/14/2010	TITLE	Princeton-11D-BRZ2	SAMSUNG ELECTRONICS
CHECK	PARK, CH	DEV. STEP	ADV1		MAIN	
APPROVAL	CHO, KS	REV	REV 0.23		CLOCK DIAGRAM	PART NO. BA41-####A
MODULE CODE	undefined	LAST EDIT	February 28, 2012 13:33:37 PM	PAGE	5	OF 40

SAMSUNG PROPRIETARY

THIS DOCUMENT CONTAINS CONFIDENTIAL PROPRIETARY INFORMATION THAT IS SAMSUNG ELECTRONICS CO.'S PROPERTY. DO NOT DISCLOSE TO OR DUPLICATE FOR OTHERS EXCEPT AS AUTHORIZED BY SAMSUNG.

CLOCK DISTRIBUTOR

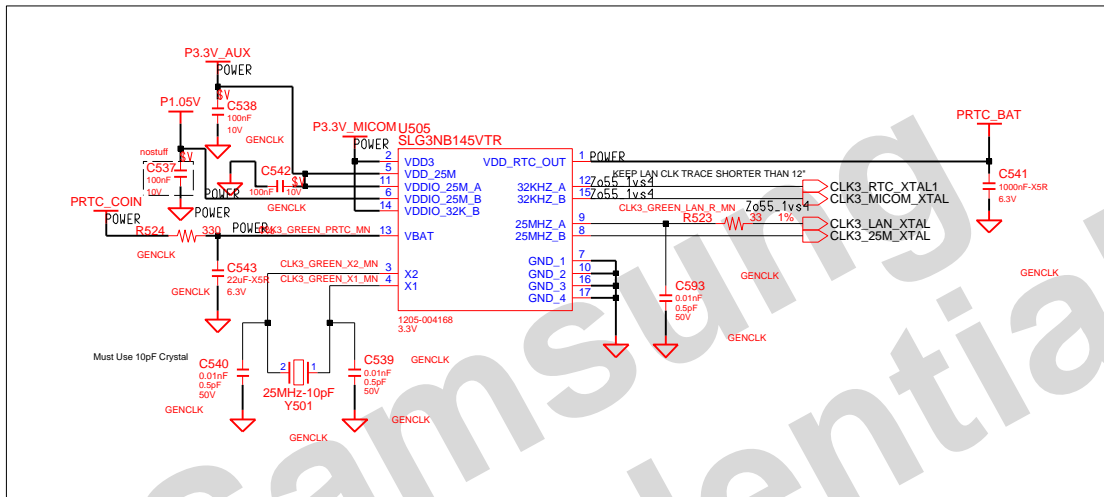

Multi Assy	Function Description	SCHEMATIC MARK
ADT_40W	40W ADAPTER SELECT	ADT_40W
ADT_60W	60W ADAPTER SELECT	ADT_60W
EMC2112	SUPPORT EMC2112	EMC2112
ATHEROS	ATHEROS SELECT	ATHEROS
BROADCOM	BROADCOM SELECT	BROADCOM
OTP_VE	THERMAL VE	OTP_VE
INT_SD	SUPPORT FCH SD	INT_SD
EXT-SD	SUPPORT EXT SD FUNCTION	EXT-SD
GENCLK	SUPPORT GREENCLK FUNCTION	GENCLK
TPM	SUPPORT TPM FUNCTION	TPM
CRYSTAL	SUPPORT EXT CRYSTAL FUNCTION	CRYSTAL
USB30	USB30 SELECT	USB30

DESIGN	LI CHEN	DATE	08/03/2012	TITLE	Lampard-14/15-INT CLOCK CLOCK DISTRIBUTION	SAMSUNG ELECTRONICS PART NO. BA41-*****A
CHECK	XIAO SUN	DEV. STEP	PV			
APPROVAL	LEI GUO	REV	REV 1.0			
MODULE CODE		LAST EDIT				
				September 25, 2012 07:52:37 AM	PAGE	6 OF 42

SAMSUNG PROPRIETARY

THIS DOCUMENT CONTAINS CONFIDENTIAL PROPRIETARY INFORMATION THAT IS SAMSUNG ELECTRONICS CO.'S PROPERTY. DO NOT DISCLOSE TO OR DUPLICATE FOR OTHERS EXCEPT AS AUTHORIZED BY SAMSUNG.

THERMAL SENSOR & FAN CONTROL

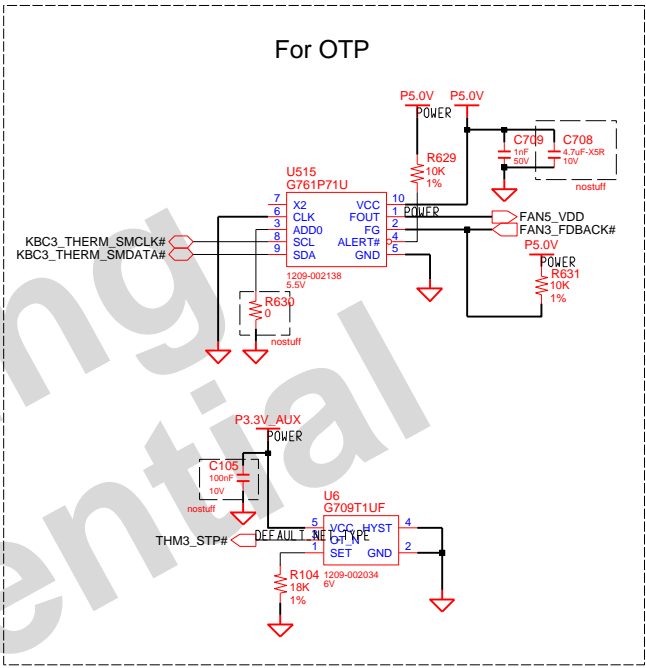
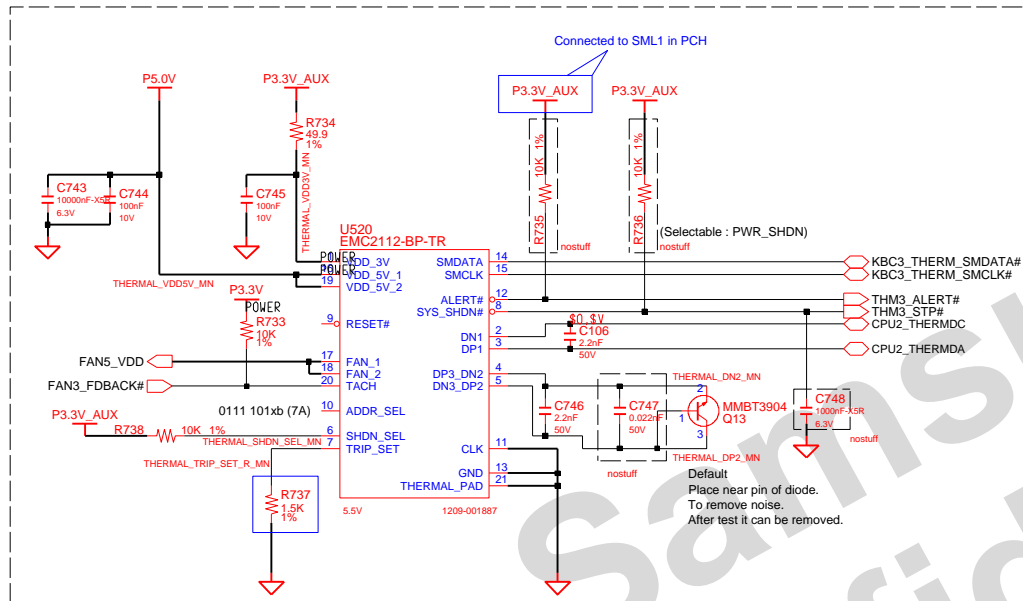

Temperature : 95.78c
 confirmed by thermal charger
 (2011.05.02)
 R (kohm) = 0.0012T - 0.9308T + 96.147

TEMPERATURE	103c	99c	95c
TRIP_SET resistor value	2.49K	2.0K	1.5K

ADDRESSSEL_MODE	
0	0101 111xb
✓ HIGH Z	0111 101xb (7A)
1	0101 110xb

SHDN_SEL_MODE	
0	INTEL TR MODE
HIGH Z	AMD CPU/DIODE MODE
✓ 1	EXT.DIODE 2 MODE

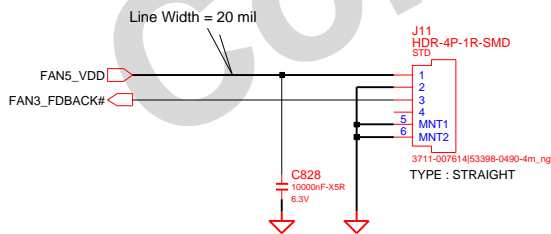

FAN PEM

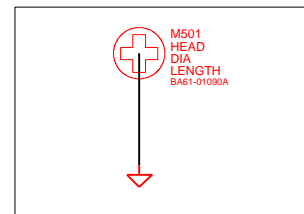

DESIGN	LI CHEN	DATE	08/03/2012	TITLE	Lampard-14/15-INT THERMAL SENSOR	SAMSUNG ELECTRONICS
CHECK	XIAO SUN	DEV. STEP	PV			
APPROVAL	LEI GUO	REV	REV 1.0			
MODULE CODE		LAST EDIT		September 25, 2012 07:52:37 AM	PAGE 7 OF 42	PART NO. BA41-*****A

SAMSUNG PROPRIETARY

THIS DOCUMENT CONTAINS CONFIDENTIAL PROPRIETARY INFORMATION THAT IS SAMSUNG ELECTRONICS CO.'S PROPERTY. DO NOT DISCLOSE TO OR DUPLICATE FOR OTHERS EXCEPT AS AUTHORIZED BY SAMSUNG.

CPU_ZACATE

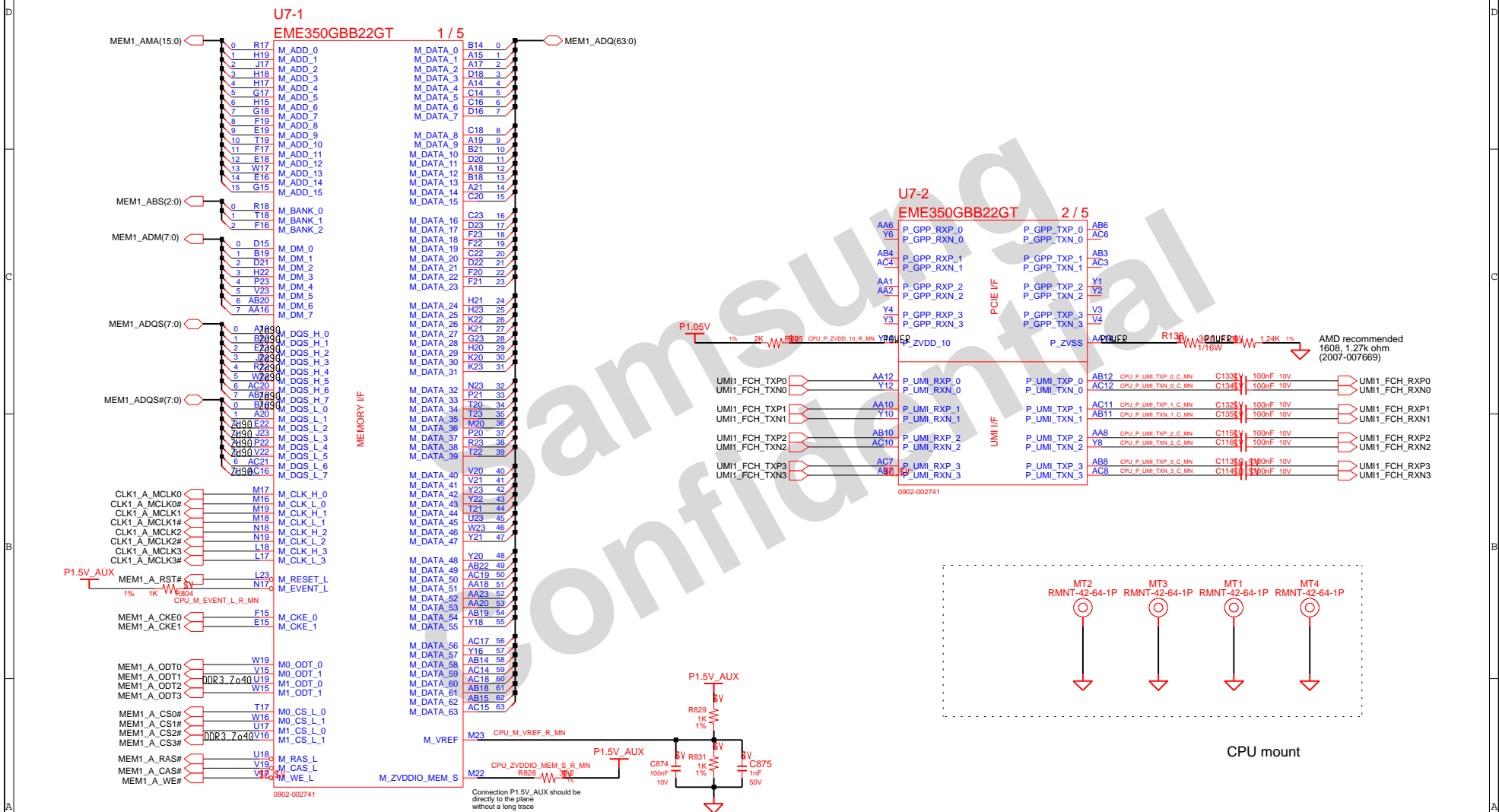

DRAW	KIM, MS	DATE	9/6/2010	TITLE	Princeton-11D-BR22 CPU ZACATE	SAMSUNG ELECTRONICS PART NO. BA41-####A
CHECK	PARK, CH	DEV. STEP	ADV1			
APPROVAL	CHO, KS	REV	REV 0.23			
MODULE CODE	undefined	LAST EDIT	February 28, 2012 13:33:37 PM	PAGE		

SAMSUNG PROPRIETARY

THIS DOCUMENT CONTAINS CONFIDENTIAL PROPRIETARY INFORMATION THAT IS SAMSUNG ELECTRONICS CO.'S PROPERTY. DO NOT DISCLOSE TO OR DUPLICATE FOR OTHERS EXCEPT AS AUTHORIZED BY SAMSUNG.

CPU_ZACATE

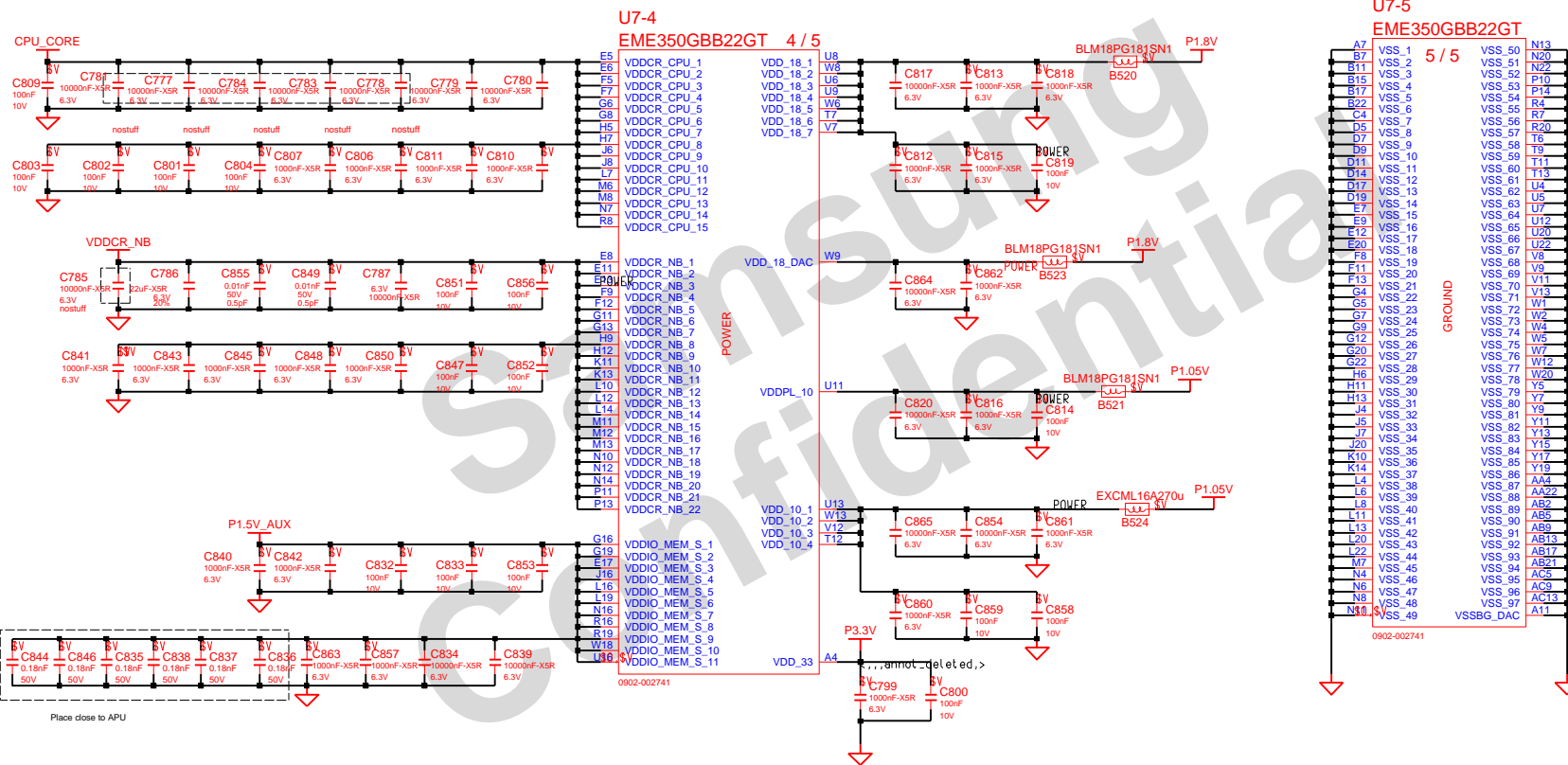

DESIGN	KIM, MS	DATE	9/6/2010	TITLE	Princeton-11D-BRZ2	SAMSUNG ELECTRONICS
CHECK	PARK, CH	DEV. STEP	ADV1	CPU	ZACATE	
APPROVAL	CHO, KS	REV	REV 0.23			PART NO. BA41-#####A
MODULE CODE		LAST EDIT	February 28, 2012 13:33:37 PM	PAGE	10	OF

SAMSUNG PROPRIETARY
 THIS DOCUMENT CONTAINS CONFIDENTIAL
 PROPRIETARY INFORMATION THAT IS
 SAMSUNG ELECTRONICS CO'S PROPERTY.
 DO NOT DISCLOSE TO OR DUPLICATE FOR OTHERS
 EXCEPT AS AUTHORIZED BY SAMSUNG.

SO-DIMM#0 : 2nd SO-DIMM
DDR SO-DIMM #0

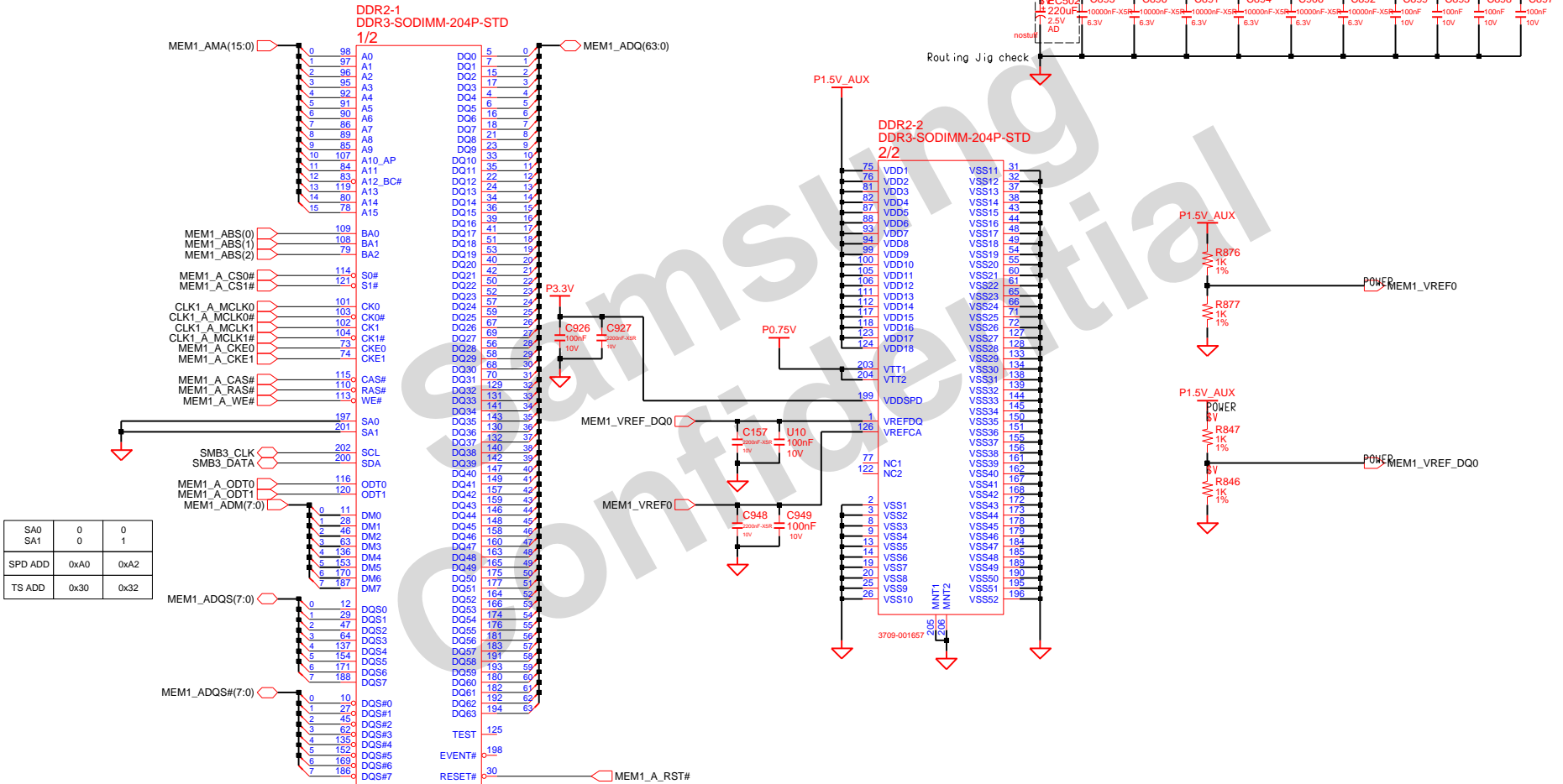

SA0	0	0
SA1	0	1
SPD ADD	0xA0	0xA2
TS ADD	0x30	0x32

DRAW	RM LI	DATE	08/03/2012	TITLE	Ramos-14/15-2SP	SAMSUNG ELECTRONICS
CHECK	XIAO SUN	DEV. STEP	DV		MEMORY #0 2 RANK(4/4)	
APPROVAL	LEI GUO	REV	REV 1.0		DDR3 2Gb	PART NO. BA41-*****A
MODULE CODE	undefined	LAST ENT			August 11, 2012 09:48:52 AM	PAGE 13 OF 56

SAMSUNG PROPRIETARY
 THIS DOCUMENT CONTAINS CONFIDENTIAL
 PROPRIETARY INFORMATION THAT IS
 SAMSUNG ELECTRONICS CO'S PROPERTY.
 DO NOT DISCLOSE TO OR DUPLICATE FOR OTHERS
 EXCEPT AS AUTHORIZED BY SAMSUNG.

SO-DIMM #1 : 1st SO-DIMM

DDR SO-DIMM #1

Height : 8 mm (STANDARD)

P/N : 3709-001615 (FOXCONN)

P/N : 3709-001622 (CONCRAFT)

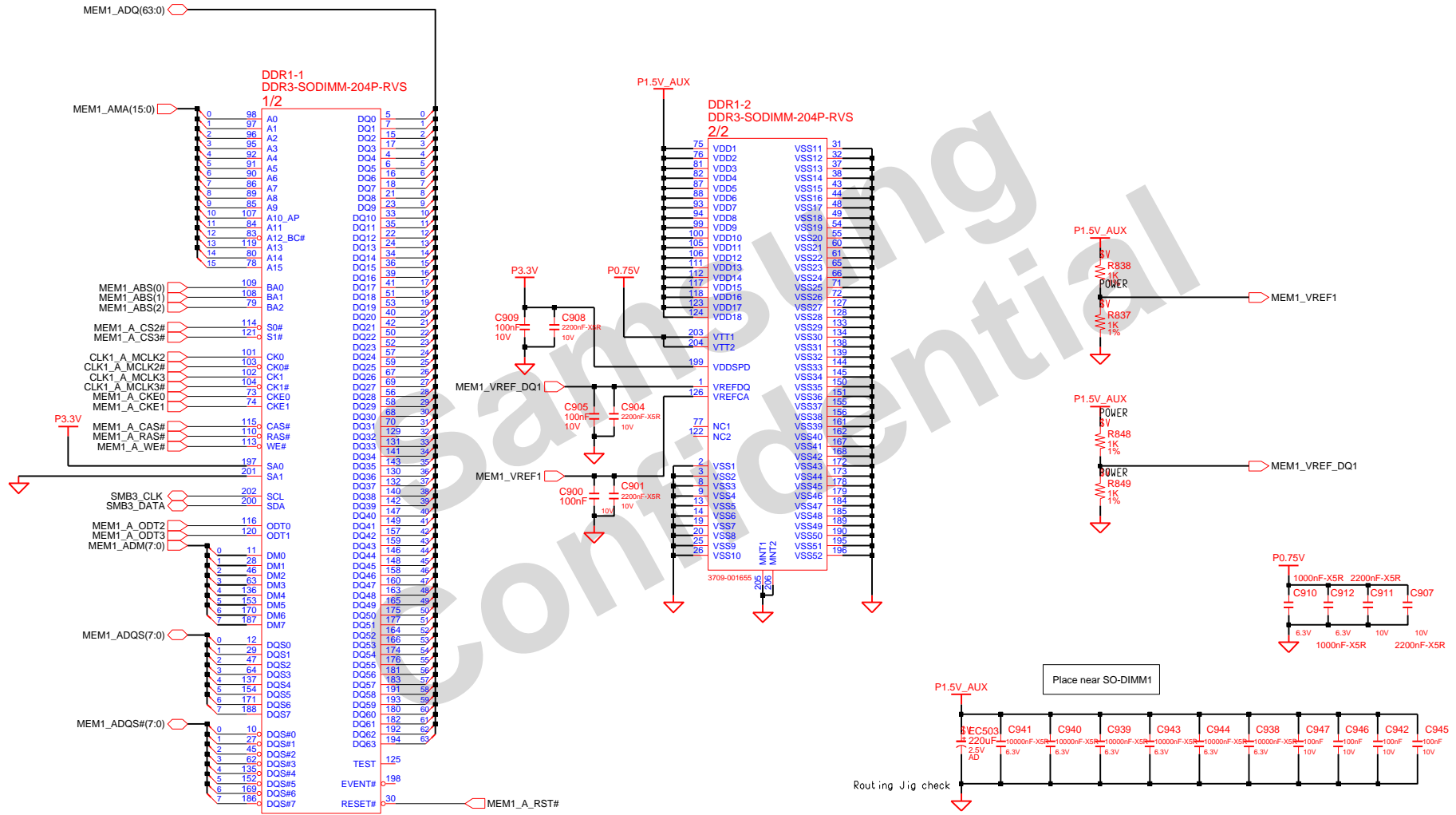

DRAW	RM LI	DATE	08/03/2012	TITLE	Ramos-14/15-2SP	SAMSUNG ELECTRONICS	
CHECK	XIAO SUN	DEV. STEP	DV		SODIMM B		
APPROVAL	LEI GUO	REV	REV 1.0		DDR3 2Gb	PART NO.	
MODULE CODE		LAST ENT				BA41-*****A	
August 11, 2012 09:48:52 AM						PAGE	14 OF 56

SAMSUNG PROPRIETARY

THIS DOCUMENT CONTAINS CONFIDENTIAL PROPRIETARY INFORMATION THAT IS SAMSUNG ELECTRONICS CO.'S PROPERTY. DO NOT DISCLOSE TO OR DUPLICATE FOR OTHERS EXCEPT AS AUTHORIZED BY SAMSUNG.

FCH_HUDSON

U4-1 BRAZOS2.0 FCH 1 / 5

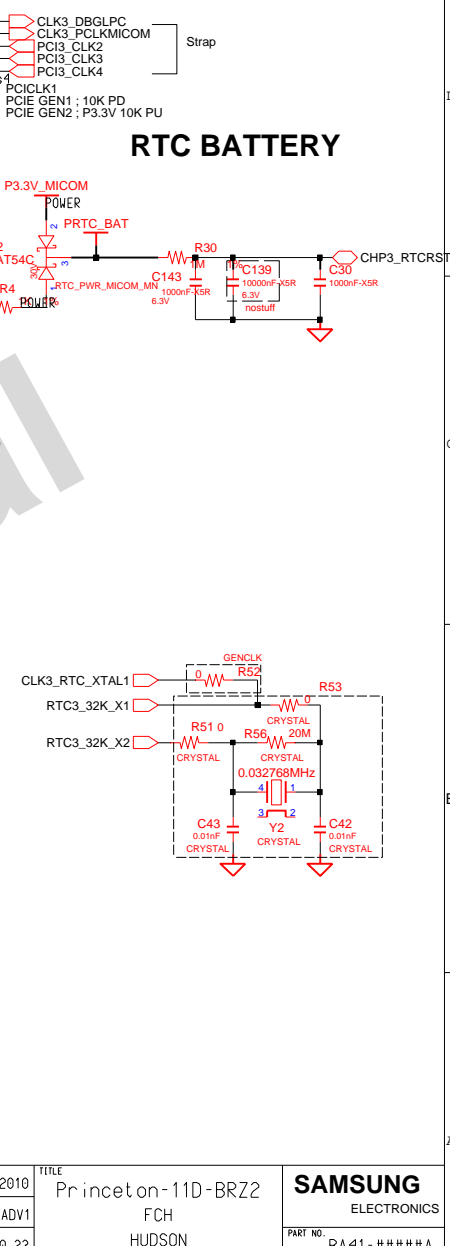
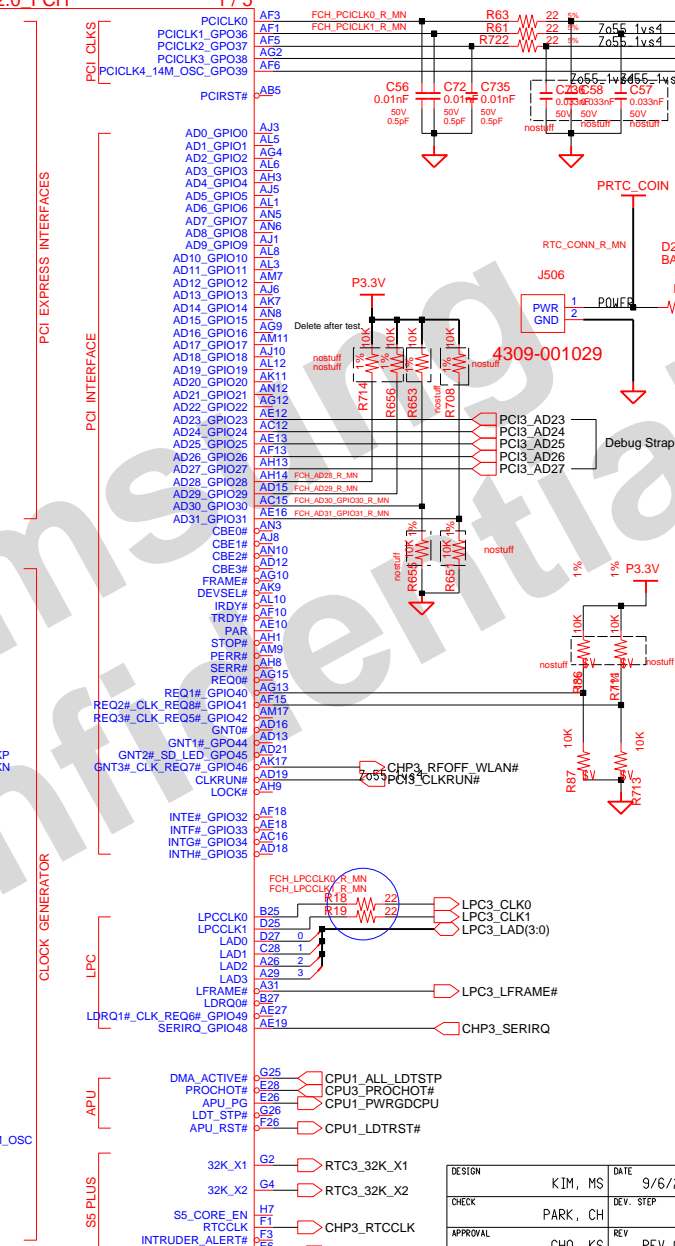
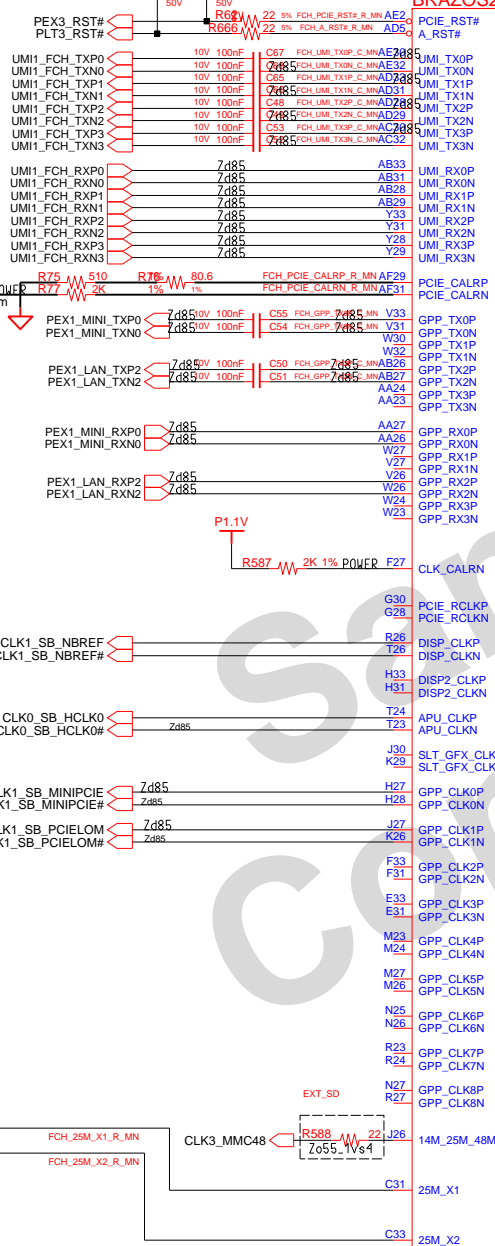

DESIGN	KIM, MS	DATE	9/6/2010	TITLE	Princeton-11D-BRZ2	SAMSUNG ELECTRONICS
CHECK	PARK, CH	DEV. STEP	ADV1	FCH		
APPROVAL	CHO, KS	REV	REV 0.23	HUDSON		PART NO. BA41-#####A
MODULE CODE		LAST EDIT	February 28, 2012 13:33:37 PM	PAGE	11	OF 40

SAMSUNG PROPRIETARY

THIS DOCUMENT CONTAINS CONFIDENTIAL PROPRIETARY INFORMATION THAT IS SAMSUNG ELECTRONICS CO.'S PROPERTY. DO NOT DISCLOSE TO OR DUPLICATE FOR OTHERS EXCEPT AS AUTHORIZED BY SAMSUNG.

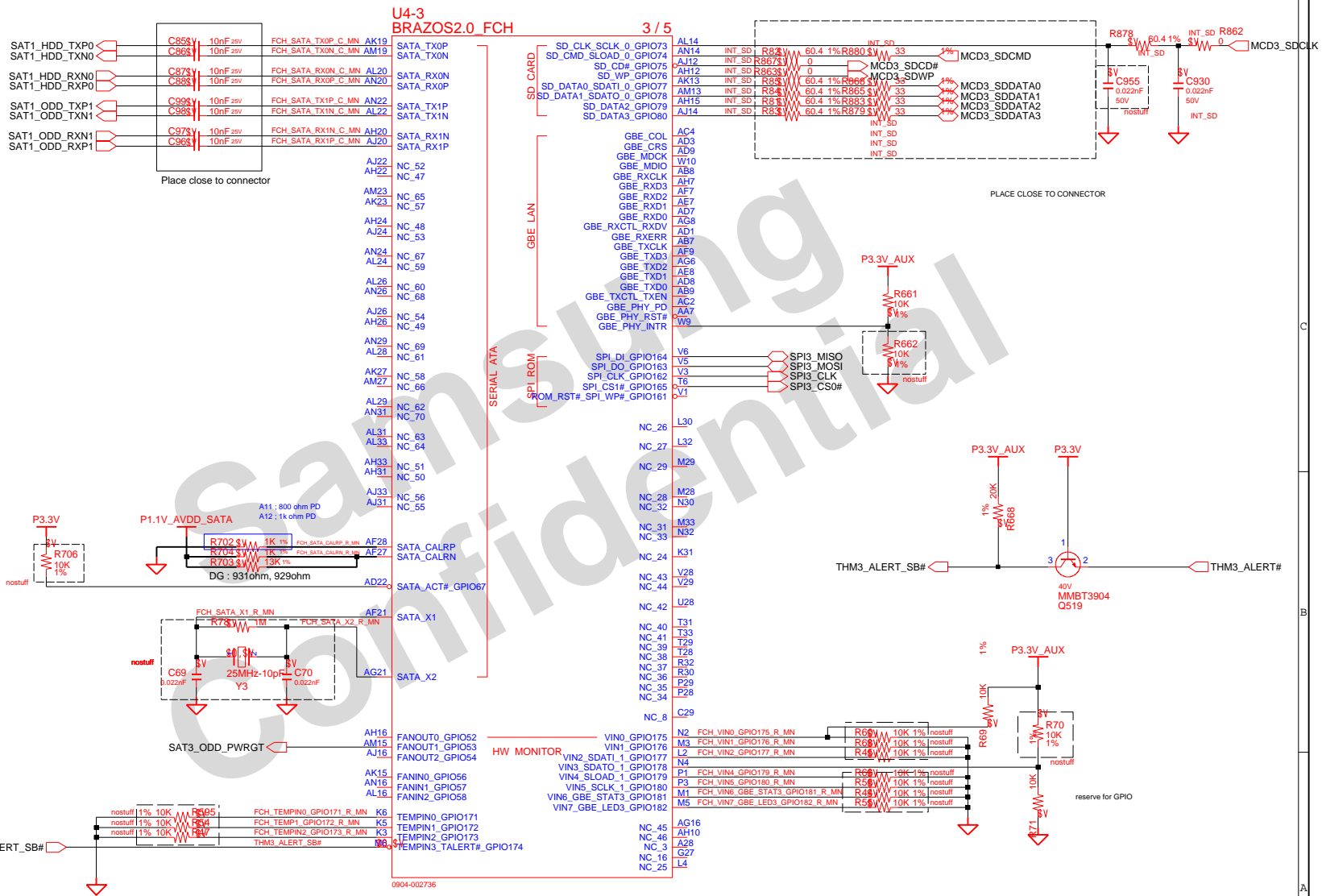

DESIGN	KIM, MS	DATE	9/6/2010	TITLE	Princeton-11D-BRZ2	SAMSUNG ELECTRONICS
CHECK	PARK, CH	DEV. STEP	ADV1	FCH		
APPROVAL	CHO, KS	REV	REV 0.23	HUDSON		PART NO. BA41-#####A
MODULE CODE		LAST EDIT	February 28, 2012 13:33:37 PM	PAGE	12	OF

SAMSUNG PROPRIETARY
 THIS DOCUMENT CONTAINS CONFIDENTIAL
 PROPRIETARY INFORMATION THAT IS
 SAMSUNG ELECTRONICS CO'S PROPERTY.
 DO NOT DISCLOSE TO OR DUPLICATE FOR OTHERS
 EXCEPT AS AUTHORIZED BY SAMSUNG.

U4-2 FCH_HUDSON
BRAZOS2.0 FCH

2 / 5

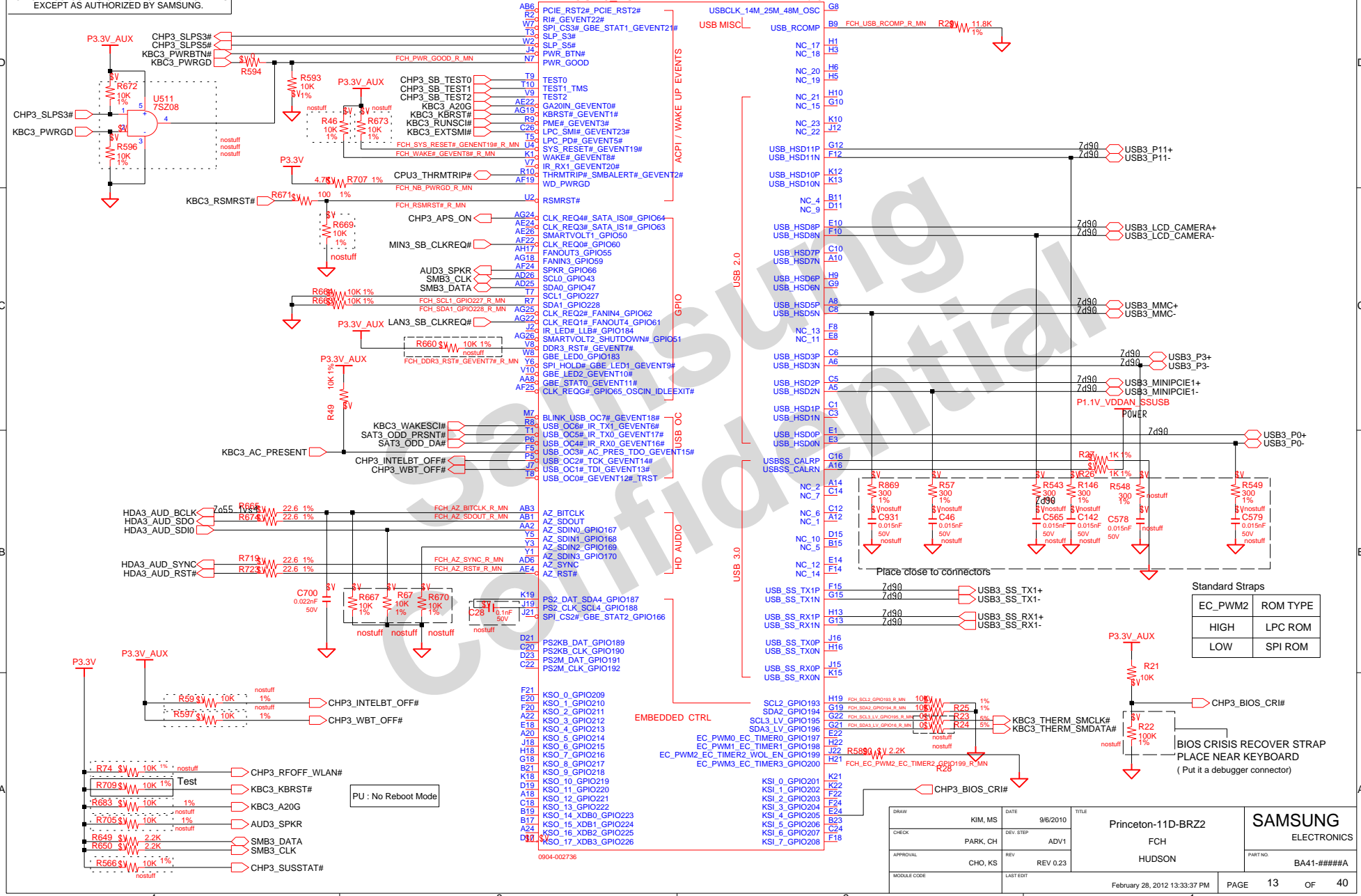

DRAW	KIM, MS	DATE	9/6/2010	TITLE	Princeton-11D-BRZ2
CHECK	PARK, CH	DEV. STEP	ADV1	FCH	
APPROVAL	CHO, KS	REV	REV 0.23	HUDSON	
MODULE CODE		LAST ENT			
					February 28, 2012 13:33:37 PM
					PAGE 13 OF 40

SAMSUNG
 ELECTRONICS
 PART NO. BA41-####A

SAMSUNG PROPRIETARY
 THIS DOCUMENT CONTAINS CONFIDENTIAL
 PROPRIETARY INFORMATION THAT IS
 SAMSUNG ELECTRONICS CO'S PROPERTY.
 DO NOT DISCLOSE TO OR DUPLICATE FOR OTHERS
 EXCEPT AS AUTHORIZED BY SAMSUNG.

FCH_HUDSON

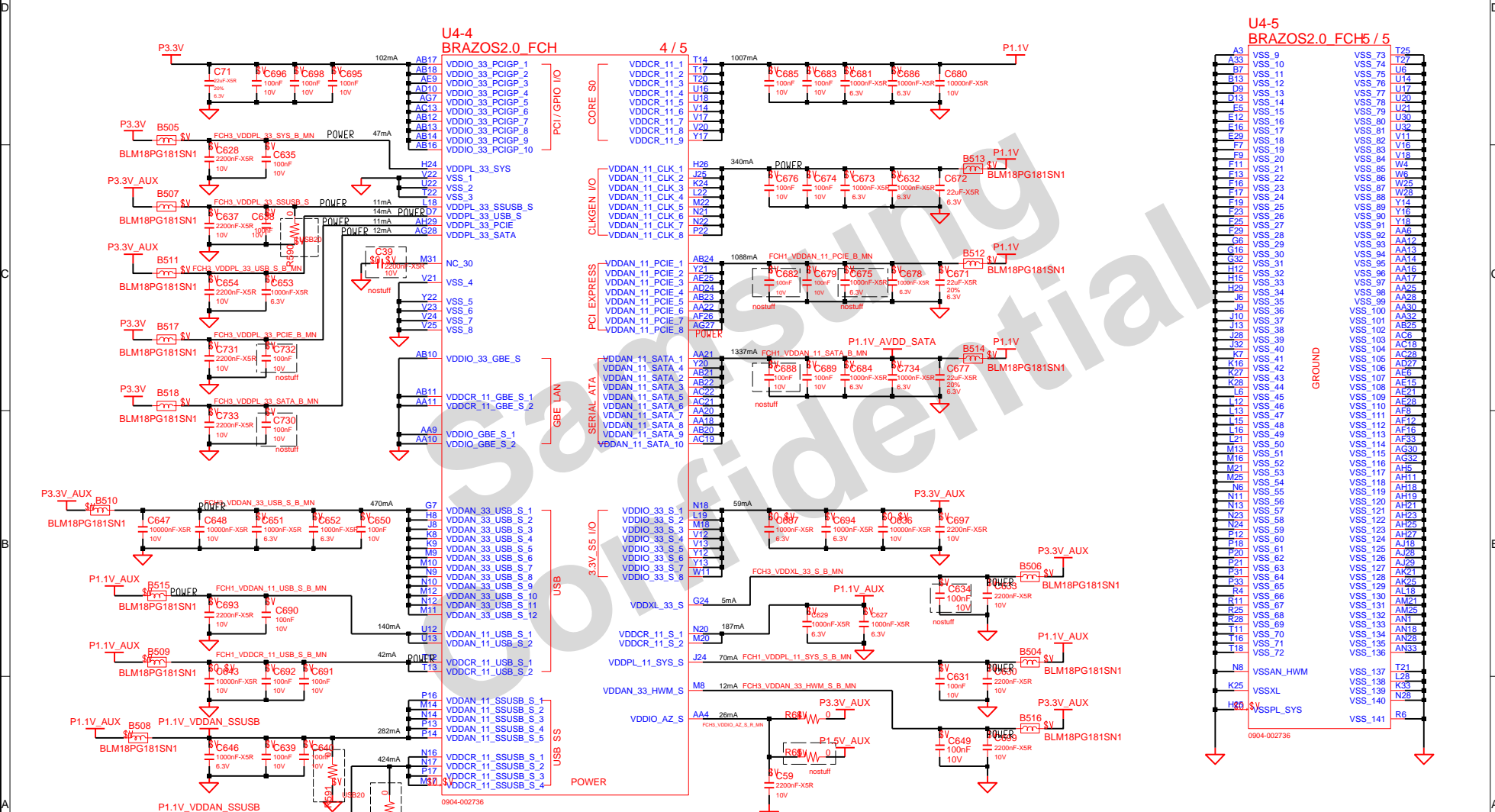

U4-5 BRAZOS2.0 FCH5/5

A3	VSS_9	VSS_73	T25
A33	VSS_10	VSS_74	T27
B7	VSS_11	VSS_75	U6
B13	VSS_12	VSS_76	U14
D9	VSS_13	VSS_77	U17
D13	VSS_14	VSS_78	U20
E5	VSS_15	VSS_79	U21
E12	VSS_16	VSS_80	U30
E16	VSS_17	VSS_81	U32
E29	VSS_18	VSS_82	V11
F7	VSS_19	VSS_83	V16
F9	VSS_20	VSS_84	V18
F11	VSS_21	VSS_85	V4
F13	VSS_22	VSS_86	V6
F16	VSS_23	VSS_87	W25
F17	VSS_24	VSS_88	W28
F19	VSS_25	VSS_89	Y12
F23	VSS_26	VSS_90	Y18
F25	VSS_27	VSS_91	Y18
F29	VSS_28	VSS_92	AA6
G6	VSS_29	VSS_93	AA12
G16	VSS_30	VSS_94	AA13
G32	VSS_31	VSS_95	AA14
H12	VSS_32	VSS_96	AA17
H15	VSS_33	VSS_97	AA17
H29	VSS_34	VSS_98	AA25
J9	VSS_35	VSS_99	AA30
J3	VSS_36	VSS_100	AA32
J10	VSS_37	VSS_101	AA32
J13	VSS_38	VSS_102	AA25
J28	VSS_39	VSS_103	AA32
K7	VSS_40	VSS_104	AA32
K16	VSS_41	VSS_105	AD27
K27	VSS_42	VSS_106	AE7
K28	VSS_43	VSS_107	AE15
L6	VSS_44	VSS_108	AE21
L12	VSS_45	VSS_109	AE28
L15	VSS_46	VSS_110	AF16
L13	VSS_47	VSS_111	AF8
L15	VSS_48	VSS_112	AF12
L16	VSS_49	VSS_113	AF33
L21	VSS_50	VSS_114	AG30
M13	VSS_51	VSS_115	AG32
M16	VSS_52	VSS_116	AH6
M21	VSS_53	VSS_117	AH11
M25	VSS_54	VSS_118	AH18
N6	VSS_55	VSS_119	AH19
N11	VSS_56	VSS_120	AH21
N13	VSS_57	VSS_121	AH23
N23	VSS_58	VSS_122	AH25
N24	VSS_59	VSS_123	AH27
P12	VSS_60	VSS_124	AJ29
P18	VSS_61	VSS_125	AJ18
P21	VSS_62	VSS_126	AJ28
P51	VSS_63	VSS_127	AK21
P3	VSS_64	VSS_128	AK25
R4	VSS_65	VSS_129	AL18
R11	VSS_66	VSS_130	AM21
R25	VSS_67	VSS_131	AM25
R28	VSS_68	VSS_132	AN1
R28	VSS_69	VSS_133	AN18
T11	VSS_70	VSS_134	AN28
T16	VSS_71	VSS_135	AN33
T18	VSS_72	VSS_136	
N8	VSSAN_HWM	VSS_137	T21
K25	VSSXL	VSS_138	L28
H29	VSSPL_SYS	VSS_139	K33
		VSS_140	N28
		VSS_141	R6

DRAW	KIM, MS	DATE	9/6/2010	TITLE	Princeton-11D-BRZ2	SAMSUNG ELECTRONICS PART NO. BA41-####A
CHECK	PARK, CH	DEV. STEP	ADV1	FCH		
APPROVAL	CHO, KS	REV	REV 0.23	HUDSON		
MODULE CODE		LAST ENT				
February 28, 2012 13:33:37 PM						PAGE 14 OF 40

SAMSUNG PROPRIETARY

THIS DOCUMENT CONTAINS CONFIDENTIAL PROPRIETARY INFORMATION THAT IS SAMSUNG ELECTRONICS CO.'S PROPERTY. DO NOT DISCLOSE TO OR DUPLICATE FOR OTHERS EXCEPT AS AUTHORIZED BY SAMSUNG.

Strap

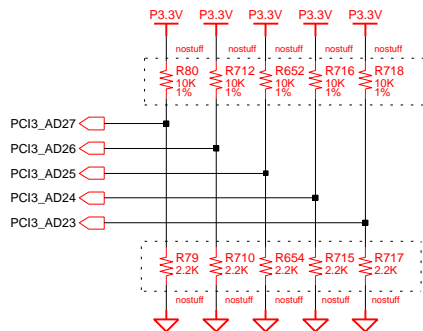

DEBUG STRAPS

	PCI3_AD(27)	PCI3_AD(25)	PCI3_AD(24)	PCI3_AD(23)
	PCI PLL	REFCLK	PCIe EEPROM	Booting from PCI memory
STRAP HIGH	USE PCI PLL	Normal REFCLK Termination	USE DEFAULT PCIE STRAPS	DISABLE PCI MEM BOOT
STRAP LOW	BYPASS PCI PLL	Inverted REFCLK Termination	USE EEPROM PCIE STRAPS	ENABLE PCI MEM BOOT

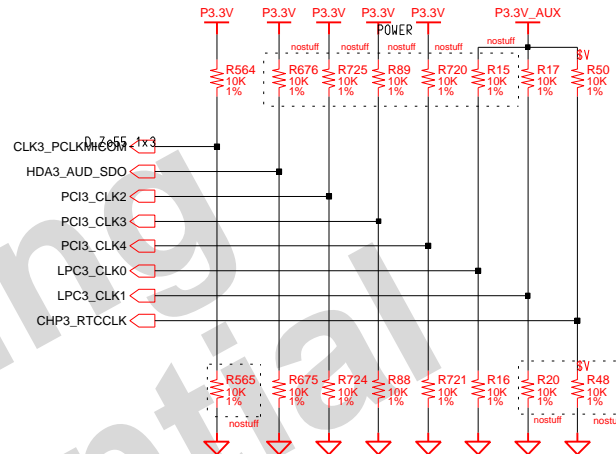

STANDARD STRAPS

	CLK3_PCLKMICOM	CHP3_RTCCCLK	PCI3_CLK3	PCI_CLK4	LPC3_CLK0	LPC3_CLK1
PULL HIGH	ALLOW PCIE GEN2 DEFAULT	S5 PLUS MODE DISABLE DEFAULT	DEBUG STRAP MODE ENABLE	non_Fusion CLOCK MODE	IMC ENABLE	CLKGEN ENABLE DEFAULT
PULL LOW	FORCE PCIE GEN1	S5 PLUS MODE ENABLE	DEBUG STRAP MODE DISABLE DEFAULT	FUSION CLOCK MODE DEFAULT	IMC DISABLED DEFAULT	CLKGEN DISABLED

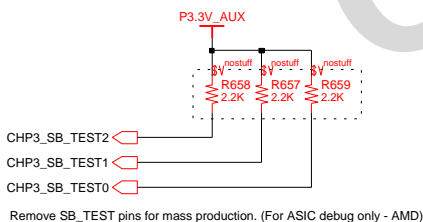

DRAW	KIM, MS	DATE	9/6/2010	TITLE	Princeton-11D-BRZ2 STRAP STRAP	SAMSUNG ELECTRONICS PART NO. BA41-####A
CHECK	PARK, CH	DEV. STEP	ADV1			
APPROVAL	CHO, KS	REV	REV 0.23			
MODULE CODE	undefined	LAST EDIT	February 28, 2012 13:33:37 PM	PAGE 15 OF 40		

SAMSUNG PROPRIETARY

THIS DOCUMENT CONTAINS CONFIDENTIAL PROPRIETARY INFORMATION THAT IS SAMSUNG ELECTRONICS CO.'S PROPERTY. DO NOT DISCLOSE TO OR DUPLICATE FOR OTHERS EXCEPT AS AUTHORIZED BY SAMSUNG.

LVDS LOGIC

Backlight On

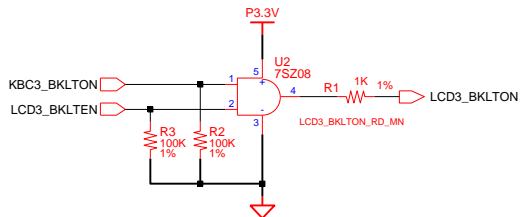

LED Power

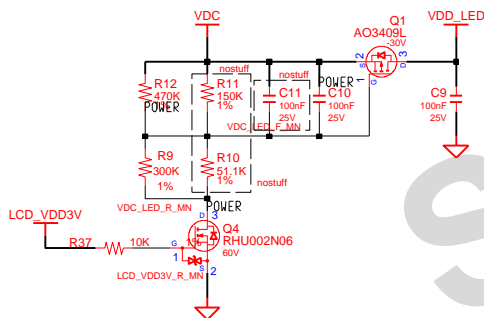

LCD Power

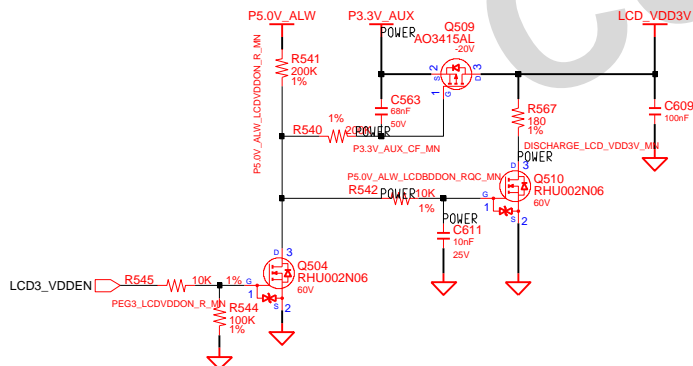

1Ch. LCD Connector + CAMERA + INT MIC

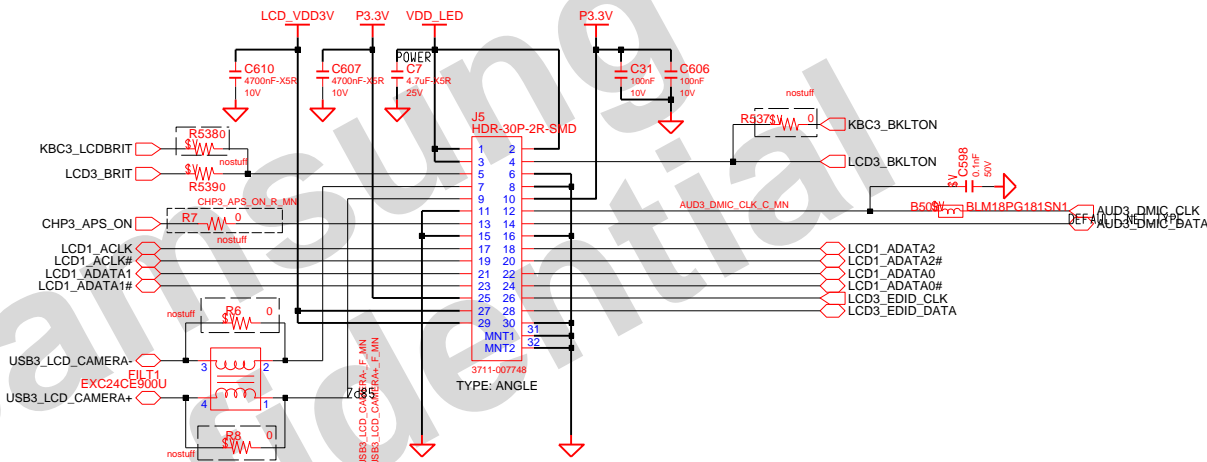

USB signal stub should be less than 100mil

DESIGN	LI CHEN	DATE	08/03/2012	TITLE	Lampard-14/15-INT	SAMSUNG ELECTRONICS
CHECK	XIAO SUN	DEV. STEP	PV		GRAPHICS_IF	
APPROVAL	LEI GUO	REV	REV 1.0		LVDS	PART NO.
MODULE CODE		LAST EDIT				BA14-*****A
				September 25, 2012 07:52:37 AM	PAGE	20 OF 42

SAMSUNG PROPRIETARY

THIS DOCUMENT CONTAINS CONFIDENTIAL PROPRIETARY INFORMATION THAT IS SAMSUNG ELECTRONICS CO.'S PROPERTY. DO NOT DISCLOSE TO OR DUPLICATE FOR OTHERS EXCEPT AS AUTHORIZED BY SAMSUNG.

VGA

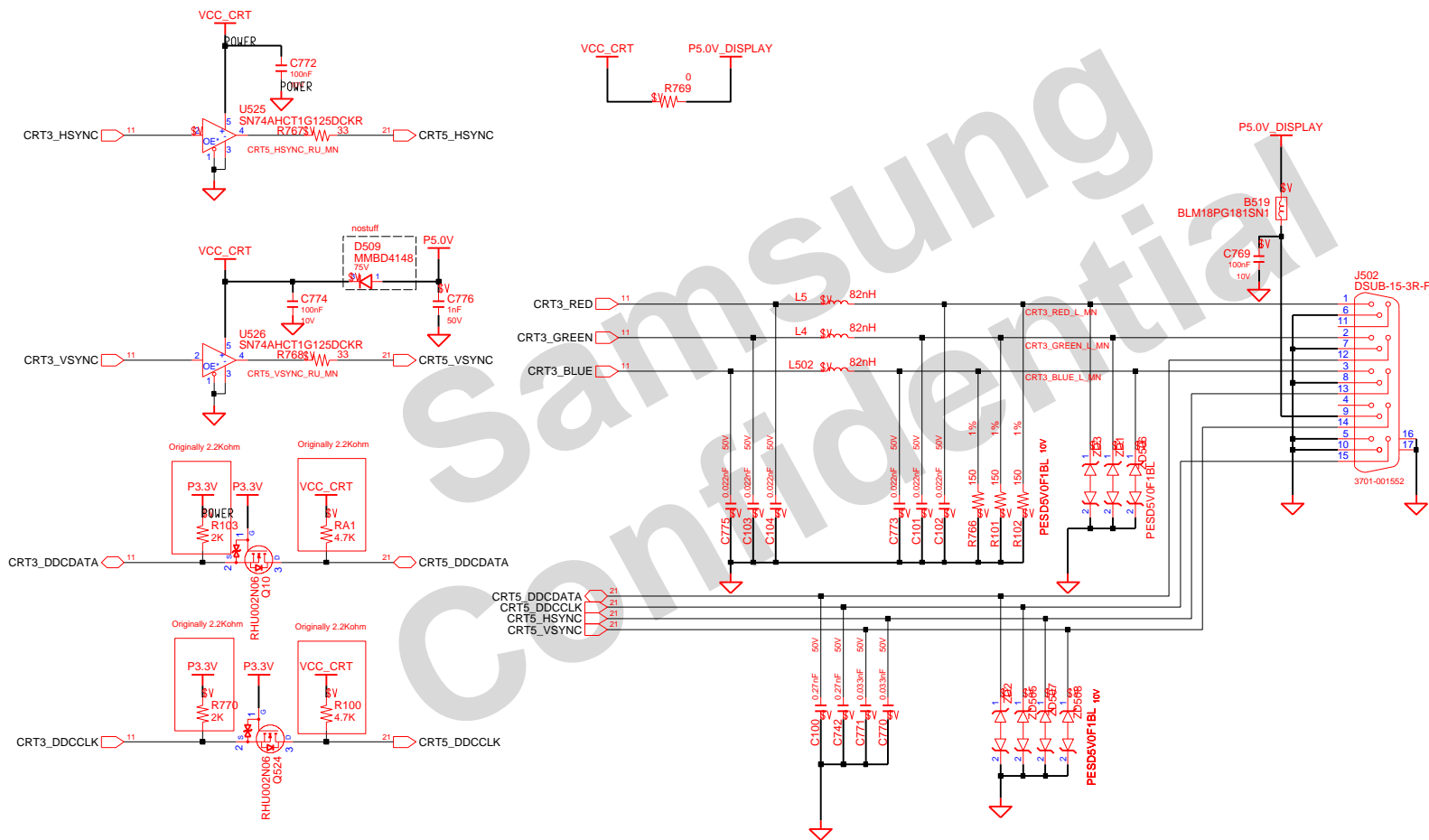

DESIGN	LI CHEN	DATE	08/03/2012	TITLE	Lampard-14/15-INT	SAMSUNG ELECTRONICS PART NO. BA41-*****A
CHECK	XIAO SUN	DEV. STEP	PV	GRAPHIC_IF		
APPROVAL	LEI GUO	REV	REV 1.0	CRT		
MODULE CODE		LAST EDIT	September 25, 2012 07:52:37 AM	PAGE	21 OF 42	

SAMSUNG PROPRIETARY

THIS DOCUMENT CONTAINS CONFIDENTIAL PROPRIETARY INFORMATION THAT IS SAMSUNG ELECTRONICS CO.'S PROPERTY. DO NOT DISCLOSE TO OR DUPLICATE FOR OTHERS EXCEPT AS AUTHORIZED BY SAMSUNG.

HDMI

After checking, Houston need to use CMC for each signal.

FOR HDMI VERIFICATION TEST

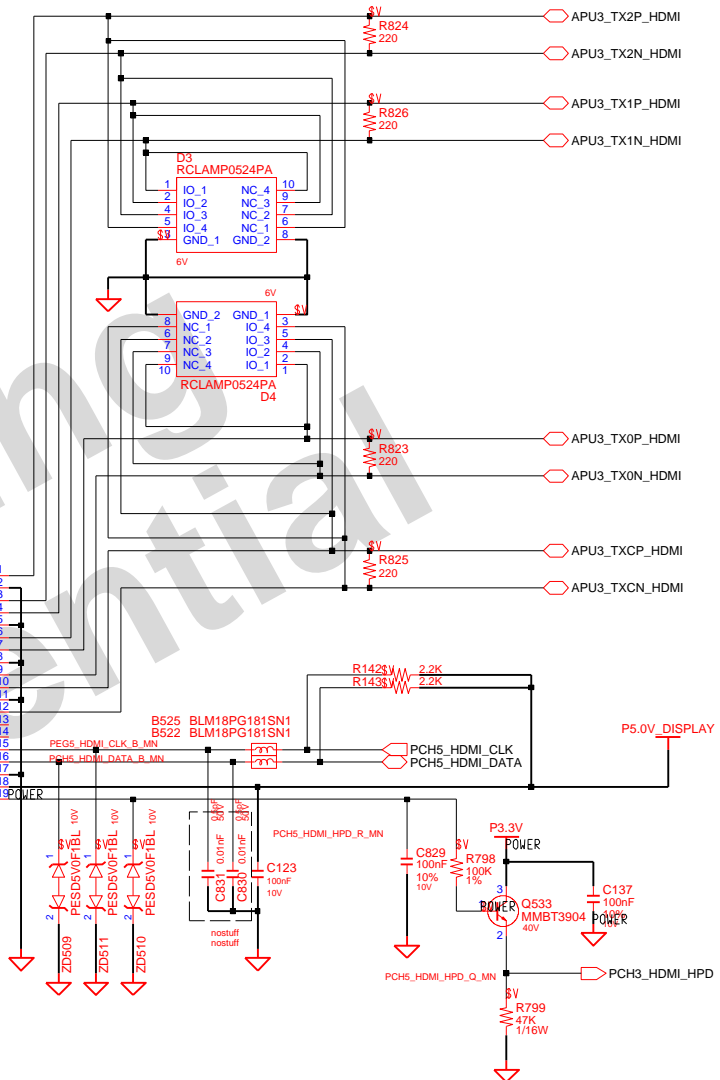
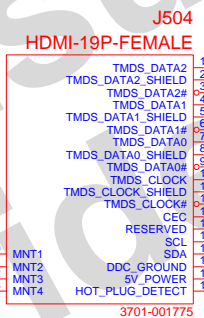
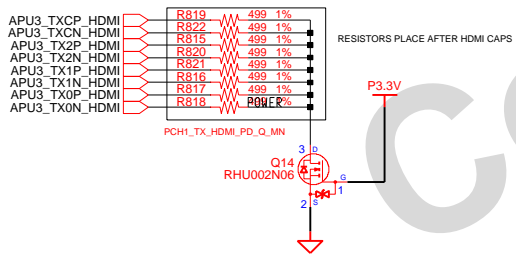
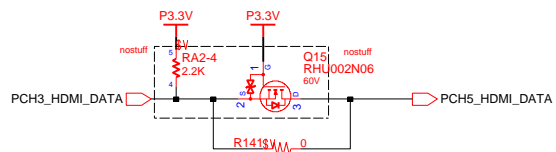
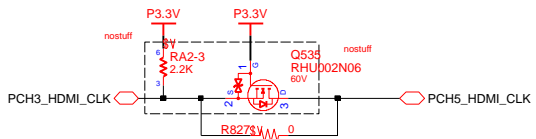

N10x/N11x_40nm HDMI/DP/LVDS support only 3.3V voltage tolerance

DESIGN	LI CHEN	DATE	08/03/2012	TITLE	Lampard-14/15-INT	SAMSUNG ELECTRONICS
CHECK	XIAO SUN	DEV. STEP	PV	GRAPHICS_IF		
APPROVAL	LEI GUO	REV	REV 1.0	HDMI		PART NO. BA41-*****A
MODULE CODE	LAST EDIT		September 25, 2012 07:52:37 AM		PAGE	22 OF 42

SAMSUNG PROPRIETARY

THIS DOCUMENT CONTAINS CONFIDENTIAL PROPRIETARY INFORMATION THAT IS SAMSUNG ELECTRONICS CO.'S PROPERTY. DO NOT DISCLOSE TO OR DUPLICATE FOR OTHERS EXCEPT AS AUTHORIZED BY SAMSUNG.

HD AUDIO

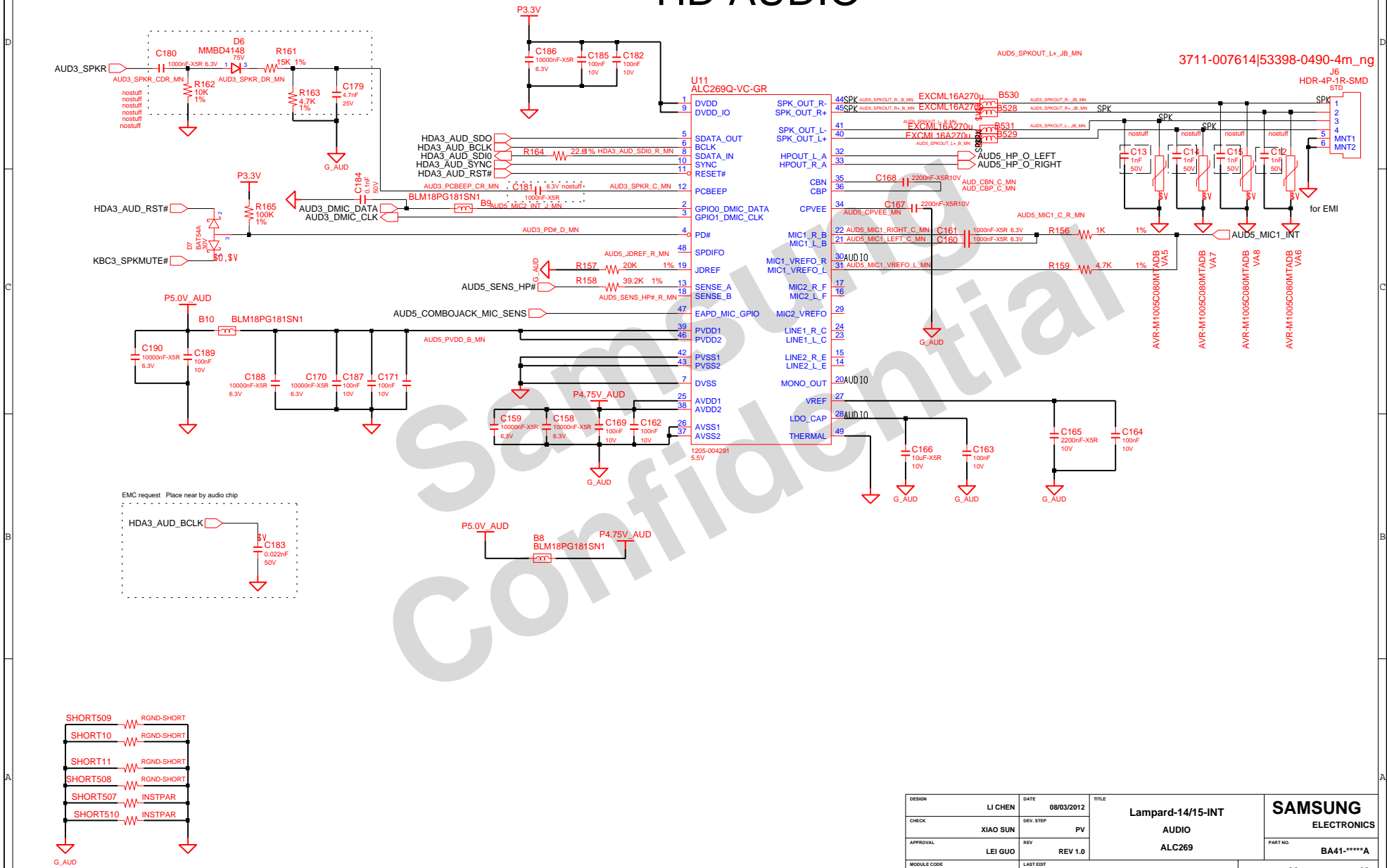

3711-007614|53398-0490-4m ng

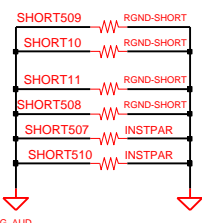
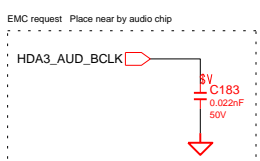

DESIGN	LI CHEN	DATE	08/03/2012	TITLE	Lampard-14/15-INT	SAMSUNG ELECTRONICS
CHECK	XIAO SUN	DEV. STEP	PV	AUDIO		
APPROVAL	LEI GUO	REV	REV 1.0	ALC269	PART NO.	BA41-*****A
MODULE CODE		LAST EDIT			September 25, 2012 07:52:37 AM	PAGE 23 OF 42

SAMSUNG PROPRIETARY

THIS DOCUMENT CONTAINS CONFIDENTIAL PROPRIETARY INFORMATION THAT IS SAMSUNG ELECTRONICS CO.'S PROPERTY. DO NOT DISCLOSE TO OR DUPLICATE FOR OTHERS EXCEPT AS AUTHORIZED BY SAMSUNG.

HD AUDIO

COMBO JACK

	B523	B522	R1002	R990	R159
MIC Switch stuff	nostuff	stuff	nostuff	nostuff	nostuff
MIC Switch nostuff	stuff	nostuff	stuff	stuff	stuff

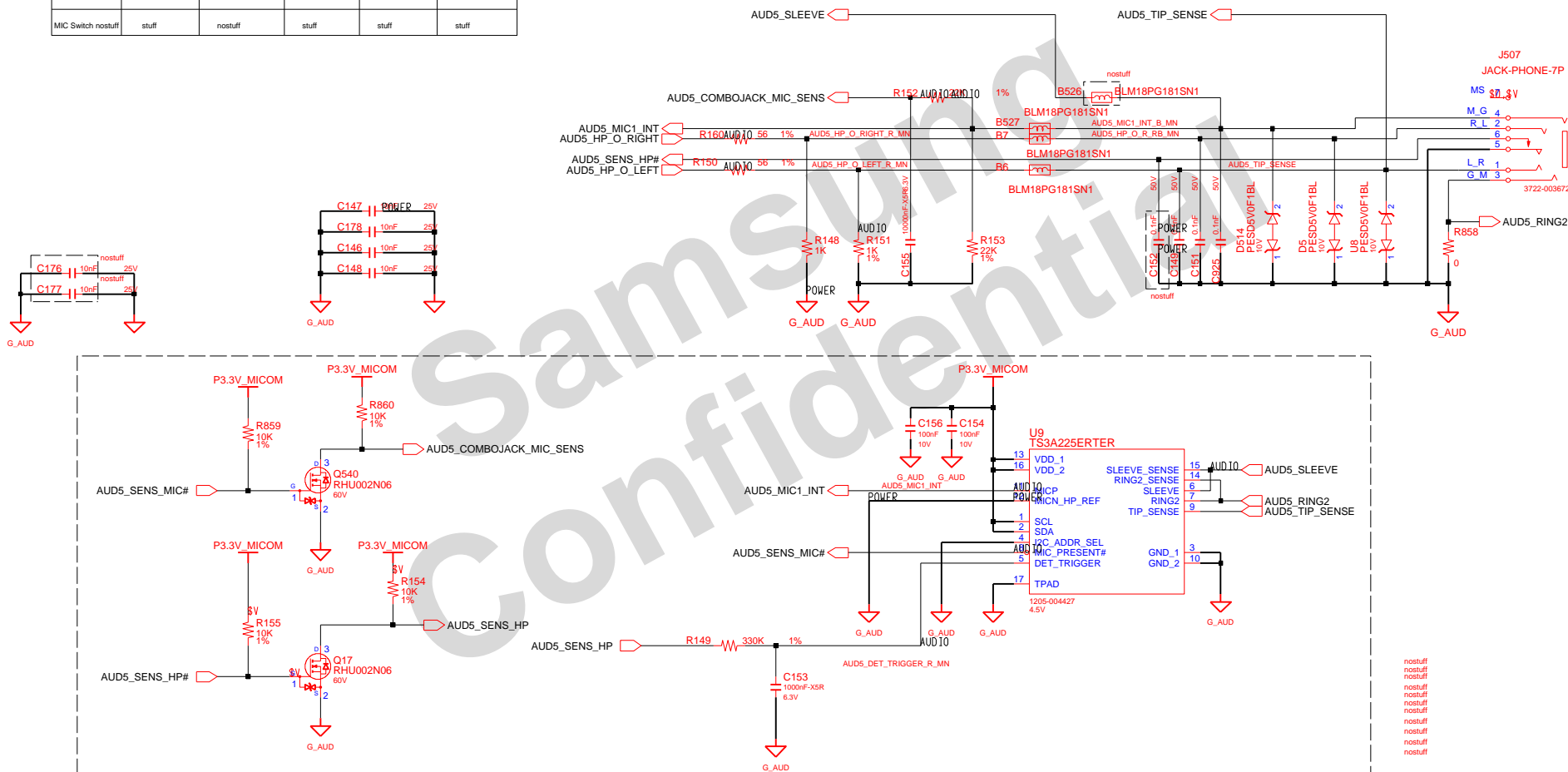

DESIGN	LI CHEN	DATE	08/03/2012	TITLE	Lampard-14/15-INT	SAMSUNG ELECTRONICS PART NO. BA41-****A
CHECK	XIAO SUN	DEV. STEP	PV	AUDIO		
APPROVAL	LEI GUO	REV	REV 1.0	AUDIO COMBO JACK		
MODULE CODE		LAST EDIT		September 25, 2012 07:52:37 AM	PAGE 24 OF 42	

SAMSUNG PROPRIETARY

THIS DOCUMENT CONTAINS CONFIDENTIAL PROPRIETARY INFORMATION THAT IS SAMSUNG ELECTRONICS CO.'S PROPERTY. DO NOT DISCLOSE TO OR DUPLICATE FOR OTHERS EXCEPT AS AUTHORIZED BY SAMSUNG.

3IN1(AU6438)

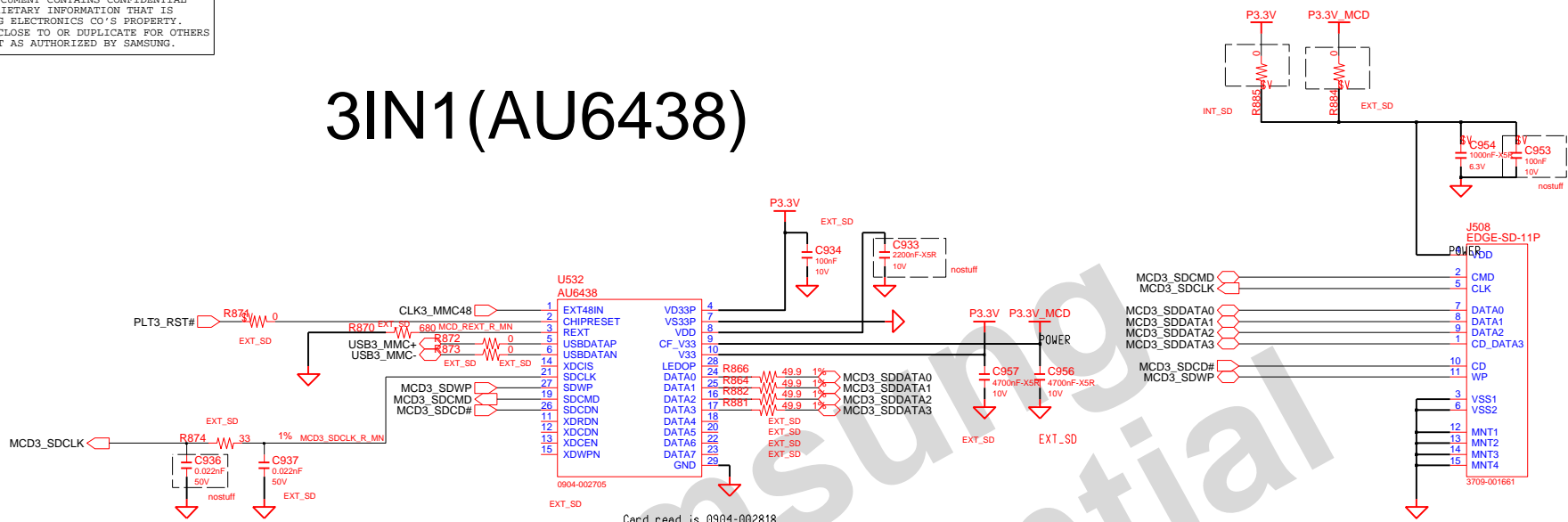

TPM1.2

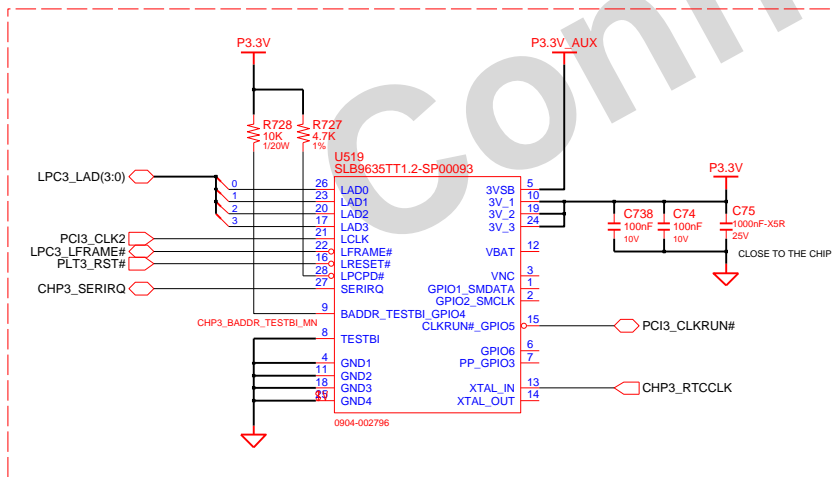

DESIGN	LI CHEN	DATE	08/03/2012	TITLE	Lampard-14/15-INT	SAMSUNG ELECTRONICS
CHECK	XIAO SUN	DEV. STEP	PV			
APPROVAL	LEI GUO	REV	REV 1.0			PART NO. BA41-*****A
MODULE CODE		LAST EDIT		September 25, 2012 07:52:37 AM	PAGE 25 OF 42	

SAMSUNG PROPRIETARY

THIS DOCUMENT CONTAINS CONFIDENTIAL PROPRIETARY INFORMATION THAT IS SAMSUNG ELECTRONICS CO.'S PROPERTY. DO NOT DISCLOSE TO OR DUPLICATE FOR OTHERS EXCEPT AS AUTHORIZED BY SAMSUNG.

Realtek RTL8105E

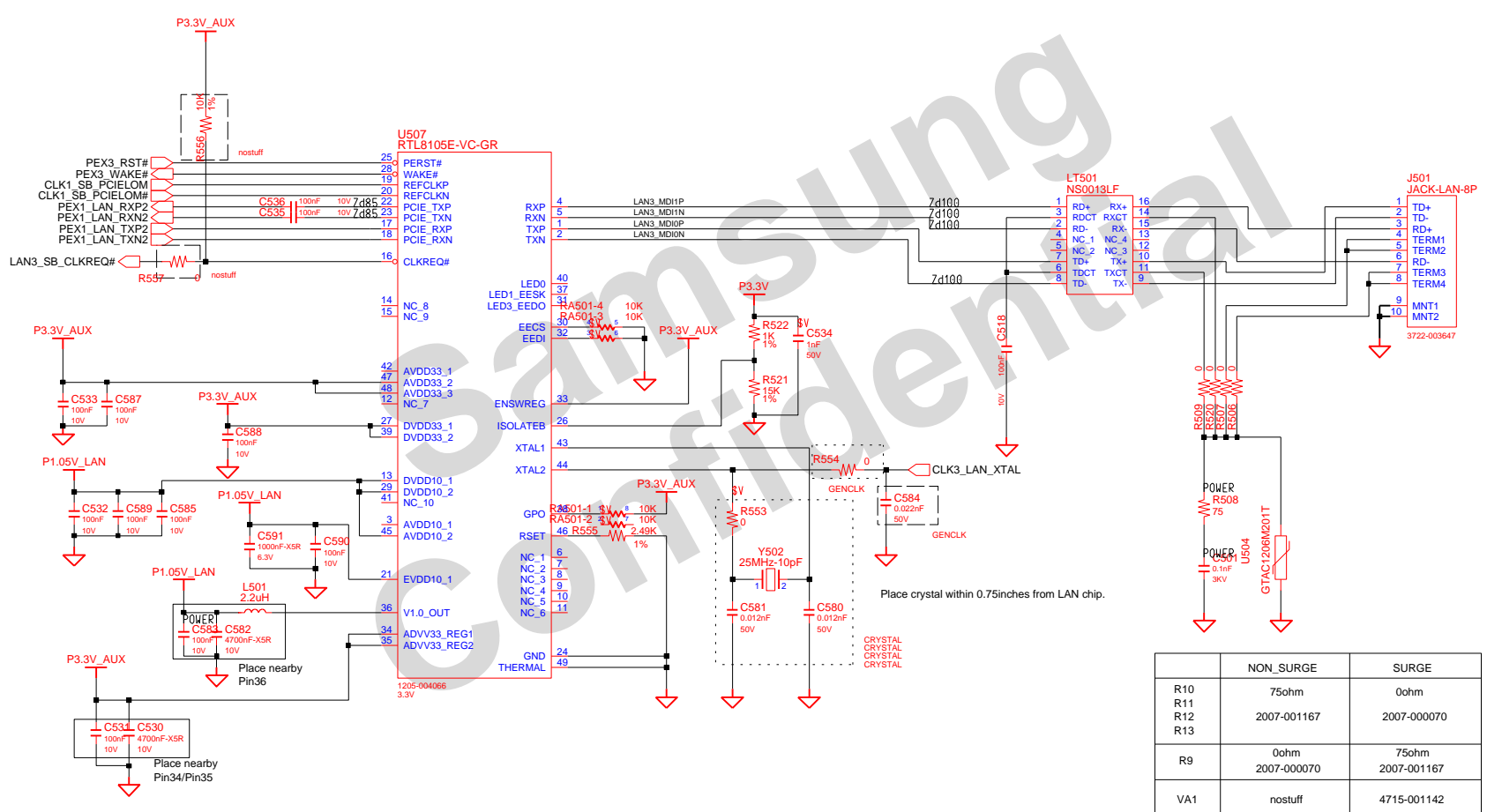

	NON_SURGE	SURGE
R10	75ohm	0ohm
R11	2007-001167	2007-000070
R12		
R13		
R9	0ohm	75ohm
	2007-000070	2007-001167
VA1	nostuff	4715-001142

DESIGN	LI CHEN	DATE	08/03/2012	TITLE	Lampard-14/15-INT	SAMSUNG ELECTRONICS
CHECK	XIAO SUN	DEV.STEP	PV		LAN	
APPROVAL	LEI GUO	REV	REV 1.0		LAN_Realtek_RTL8111E)	PART NO.
MODULE CODE		LAST EDIT				BA41-*****A
September 25, 2012 07:52:37 AM						PAGE 26 OF 42

SAMSUNG PROPRIETARY

THIS DOCUMENT CONTAINS CONFIDENTIAL PROPRIETARY INFORMATION THAT IS SAMSUNG ELECTRONICS CO.'S PROPERTY. DO NOT DISCLOSE TO OR DUPLICATE FOR OTHERS EXCEPT AS AUTHORIZED BY SAMSUNG.

WLAN

CLKREQ# pin on PCH is SUS Well to support both AMT & noAMT

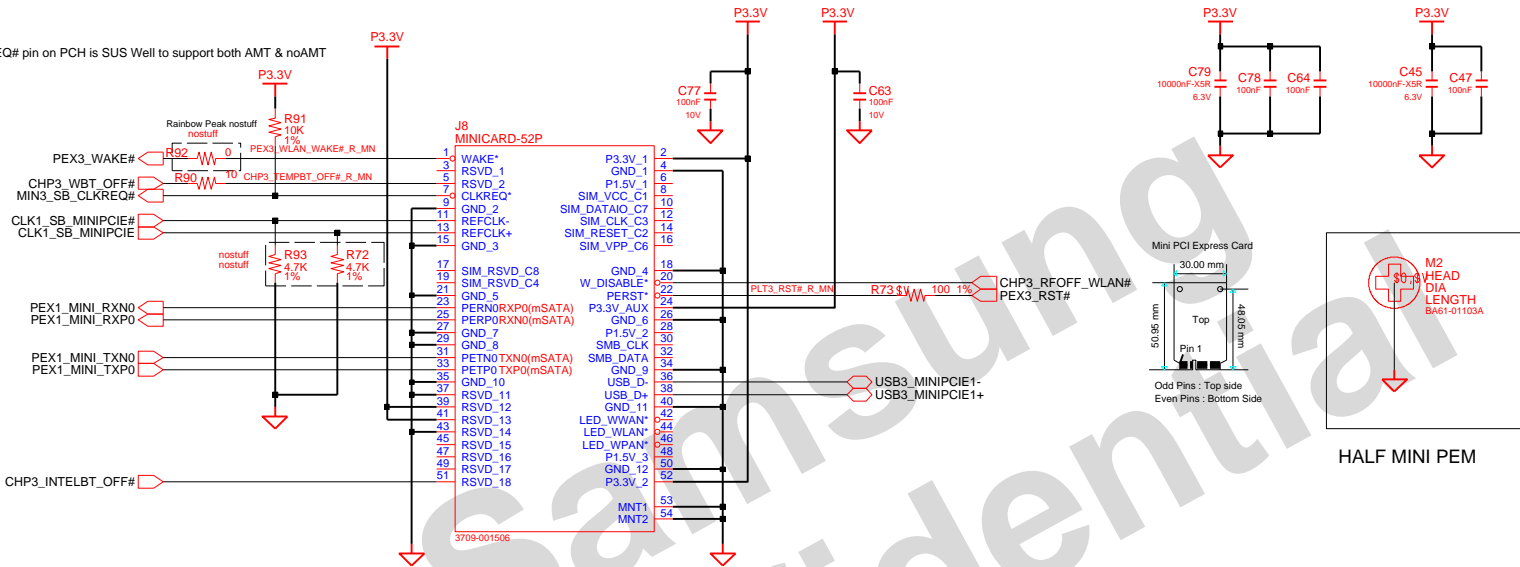

HALF MINI PEM

DESIGN	LI CHEN	DATE	08/03/2012	TITLE	Lampard-14/15-INT	SAMSUNG ELECTRONICS PART NO. BA41-*****A
CHECK	XIAO SUN	DEV.STEP	PV		WLAN	
APPROVAL	LEI GUO	REV	REV 1.0		WLAN	
MODULE CODE		LAST EDIT		September 25, 2012 07:52:37 AM	PAGE 27 OF 42	

SAMSUNG PROPRIETARY

THIS DOCUMENT CONTAINS CONFIDENTIAL PROPRIETARY INFORMATION THAT IS SAMSUNG ELECTRONICS CO.'S PROPERTY. DO NOT DISCLOSE TO OR DUPLICATE FOR OTHERS EXCEPT AS AUTHORIZED BY SAMSUNG.

SATA I/F CONN

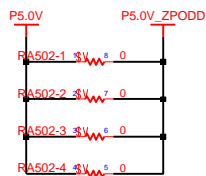
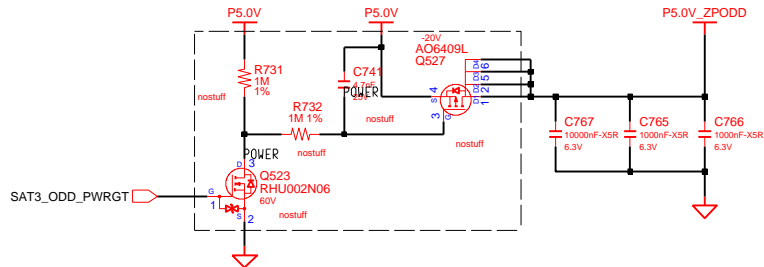

SATA HDD CONN

Cable Connector Type

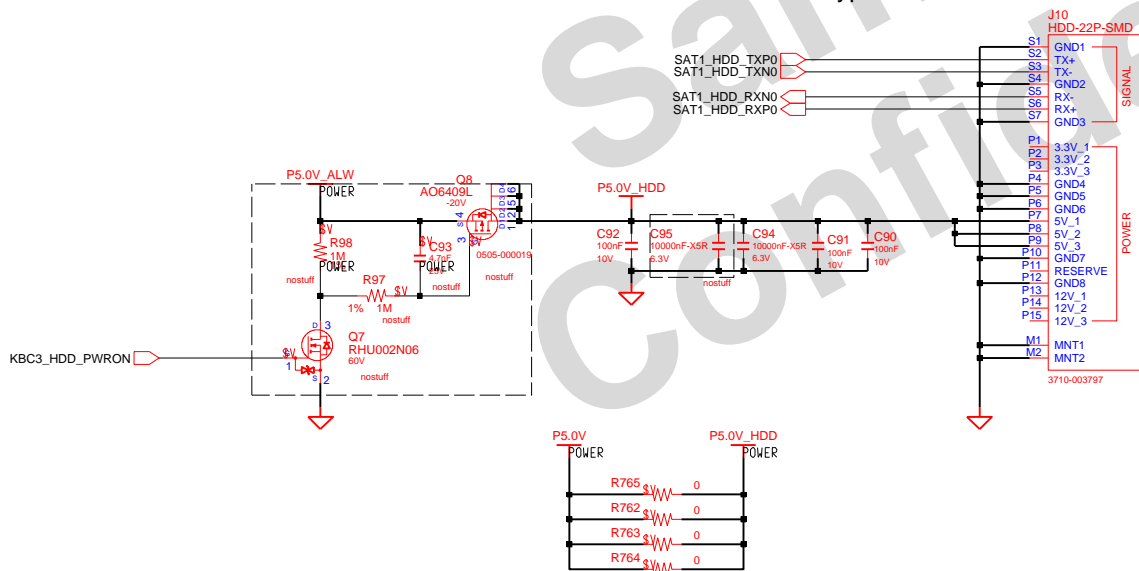

SATA ODD CONN

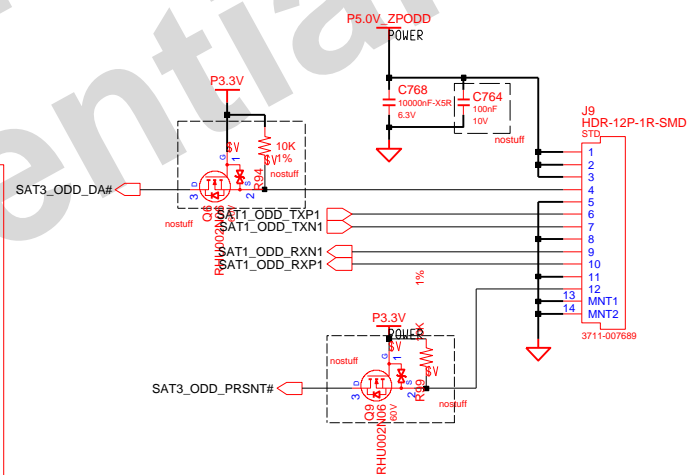

DESIGN	LI CHEN	DATE	08/03/2012	TITLE	Lampard-14/15-INT	SAMSUNG ELECTRONICS
CHECK	XIAO SUN	DEV. STEP	PV	SATA I/F		
APPROVAL	LEI GUO	REV	REV 1.0	SATA I/F		PART NO. BA41-****A
MODULE CODE		LAST EDIT		September 25, 2012 07:52:37 AM	PAGE 28	OF 42

SAMSUNG PROPRIETARY

THIS DOCUMENT CONTAINS CONFIDENTIAL PROPRIETARY INFORMATION THAT IS SAMSUNG ELECTRONICS CO.'S PROPERTY. DO NOT DISCLOSE TO OR DUPLICATE FOR OTHERS EXCEPT AS AUTHORIZED BY SAMSUNG.

Micom Glue

KEYBOARD

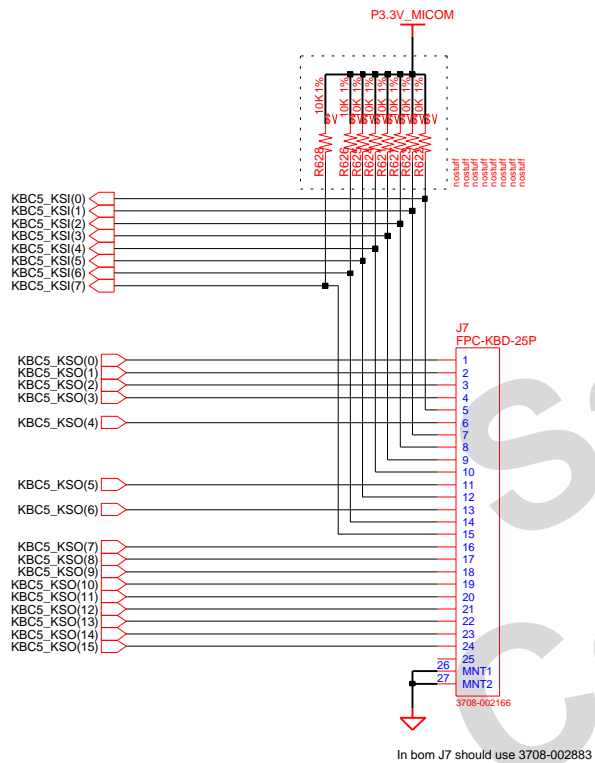

LID3_SWITCH

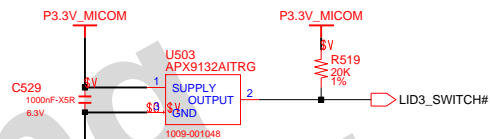

80H PORT DEBUG

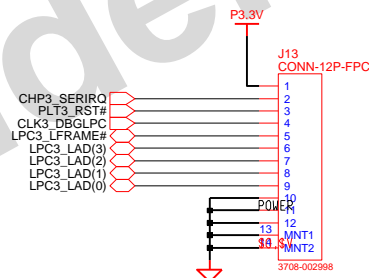

DRAW	LI CHEN	DATE	08/03/2012	TITLE	Lampard-14/15-INT	SAMSUNG ELECTRONICS
CHECK	XIAO SUN	DEV. STEP	PV	MICOM		
APPROVAL	LEI GUO	REV	REV 1.0	MICOM GLUE LOGIC	PART NO.	BA41-*****A
MODULE CODE		LAST EDIT		September 25, 2012 07:52:37 AM	PAGE	30 OF 42

SAMSUNG PROPRIETARY

THIS DOCUMENT CONTAINS CONFIDENTIAL PROPRIETARY INFORMATION THAT IS SAMSUNG ELECTRONICS CO.'S PROPERTY. DO NOT DISCLOSE TO OR DUPLICATE FOR OTHERS EXCEPT AS AUTHORIZED BY SAMSUNG.

USB 3.0 CONNECTOR

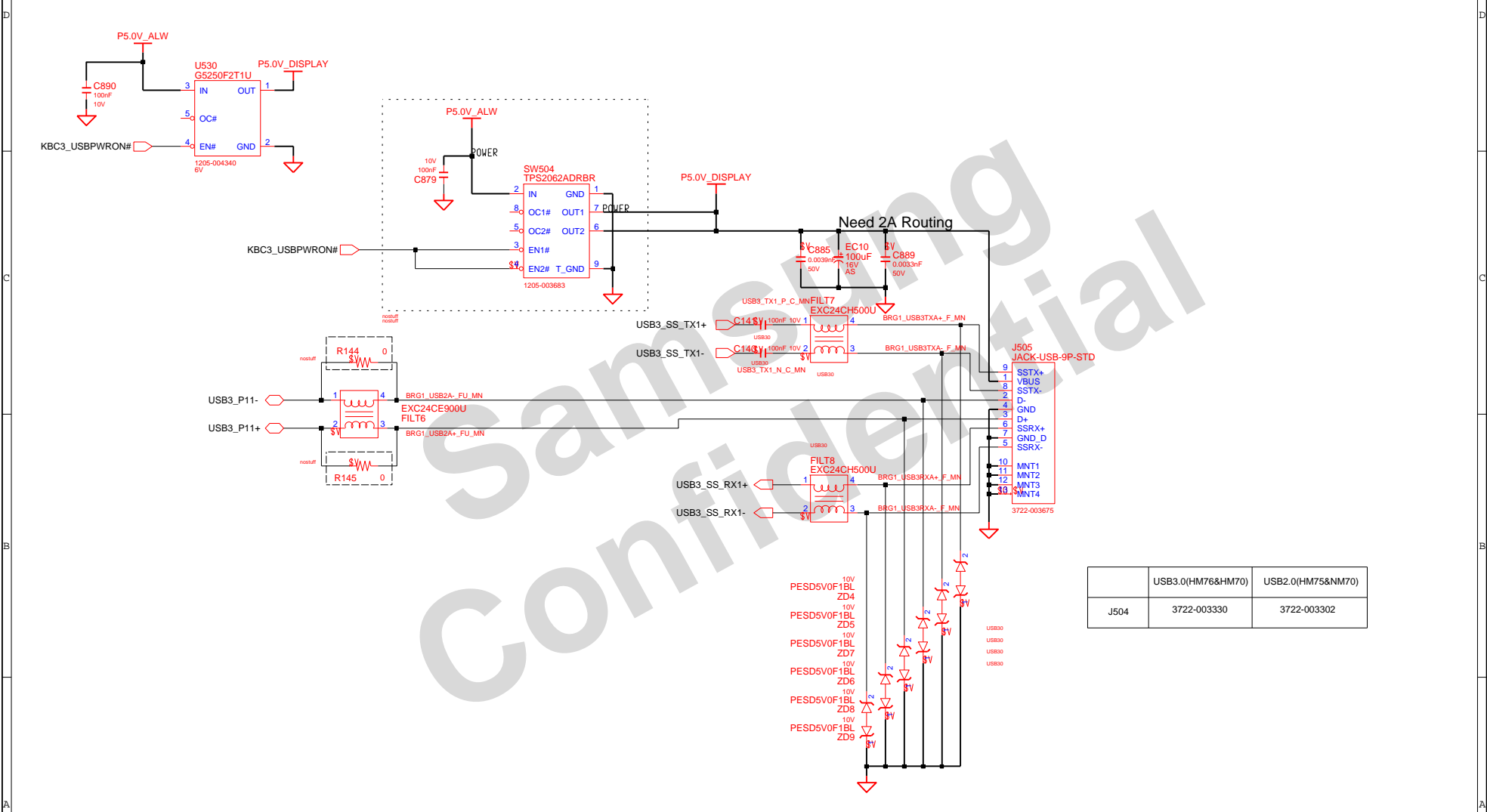

	USB3.0(HM76&HM70)	USB2.0(HM75&NM70)
J504	3722-003330	3722-003302

DRAW	LI CHEN	DATE	08/03/2012	TITLE	Lampard-14/15-INT	SAMSUNG ELECTRONICS
CHECK	XIAO SUN	DEV. STEP	PV		USB3.0	
APPROVAL	LEI GUO	REV	REV 1.0		USB 3.0 CONNECTOR	PART NO. BA41-*****A
MODULE CODE		LAST EDIT		September 25, 2012 07:52:37 AM	PAGE	31 OF 42

SAMSUNG PROPRIETARY

THIS DOCUMENT CONTAINS CONFIDENTIAL PROPRIETARY INFORMATION THAT IS SAMSUNG ELECTRONICS CO.'S PROPERTY. DO NOT DISCLOSE TO OR DUPLICATE FOR OTHERS EXCEPT AS AUTHORIZED BY SAMSUNG.

MAIN TO SUB

MAIN to 3-in-1 / USB SUB

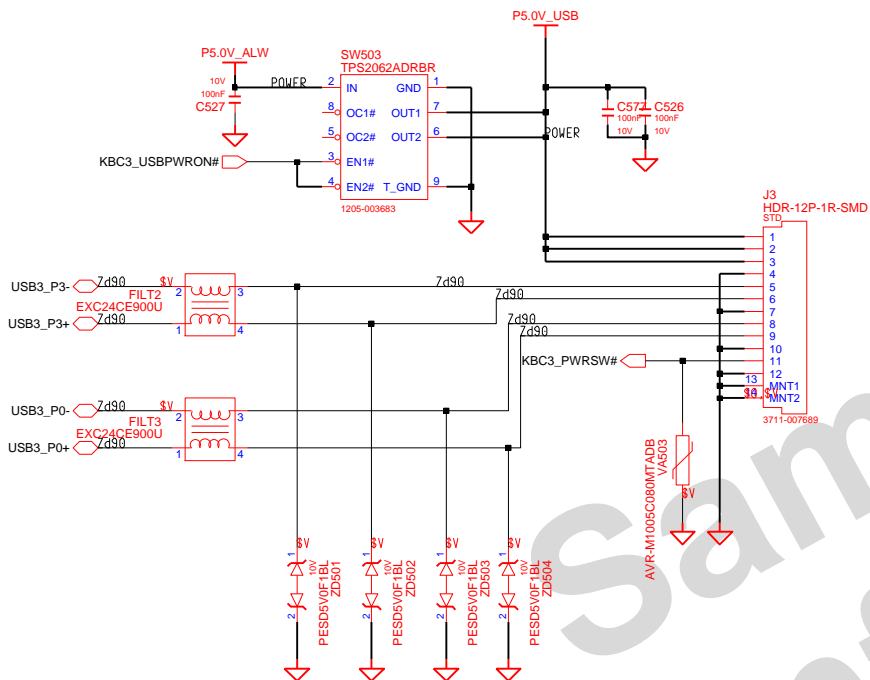

TOUCHPAD & LED MAIN TO SUB

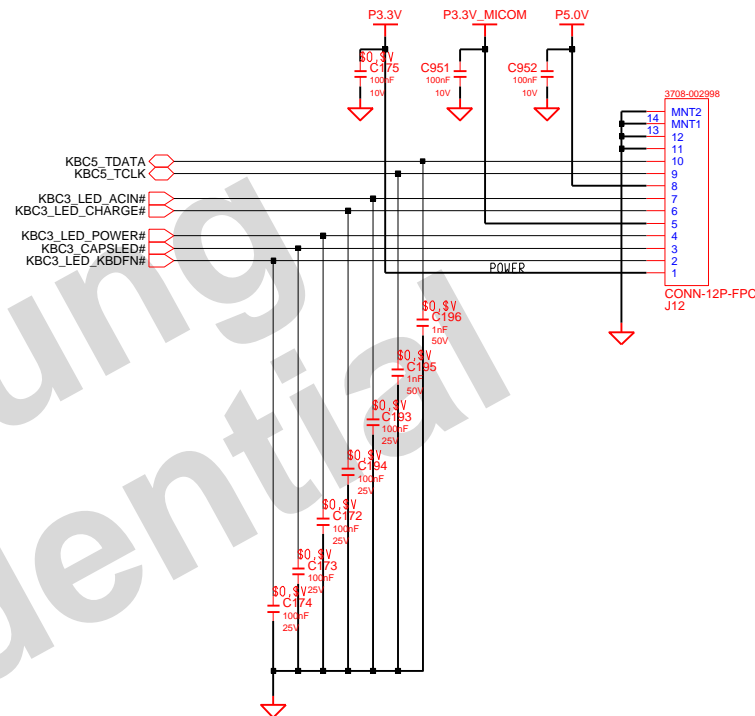

Samsung Confidential

DESIGN	LI CHEN	DATE	08/03/2012	TITLE	Lampard-14/15-INT SUB BOARD CONNECTOR MAIN TO SUB	SAMSUNG ELECTRONICS PART NO. BA41-*****A
CHECK	XIAO SUN	DEV. STEP	PV			
APPROVAL	LEI GUO	REV	REV 1.0			
MODULE CODE		LAST EDIT				
				September 25, 2012 07:52:37 AM	PAGE	32 OF 42

SAMSUNG PROPRIETARY

THIS DOCUMENT CONTAINS CONFIDENTIAL PROPRIETARY INFORMATION THAT IS SAMSUNG ELECTRONICS CO.'S PROPERTY. DO NOT DISCLOSE TO OR DUPLICATE FOR OTHERS EXCEPT AS AUTHORIZED BY SAMSUNG.

CHARGER & POWER MANAGEMENT

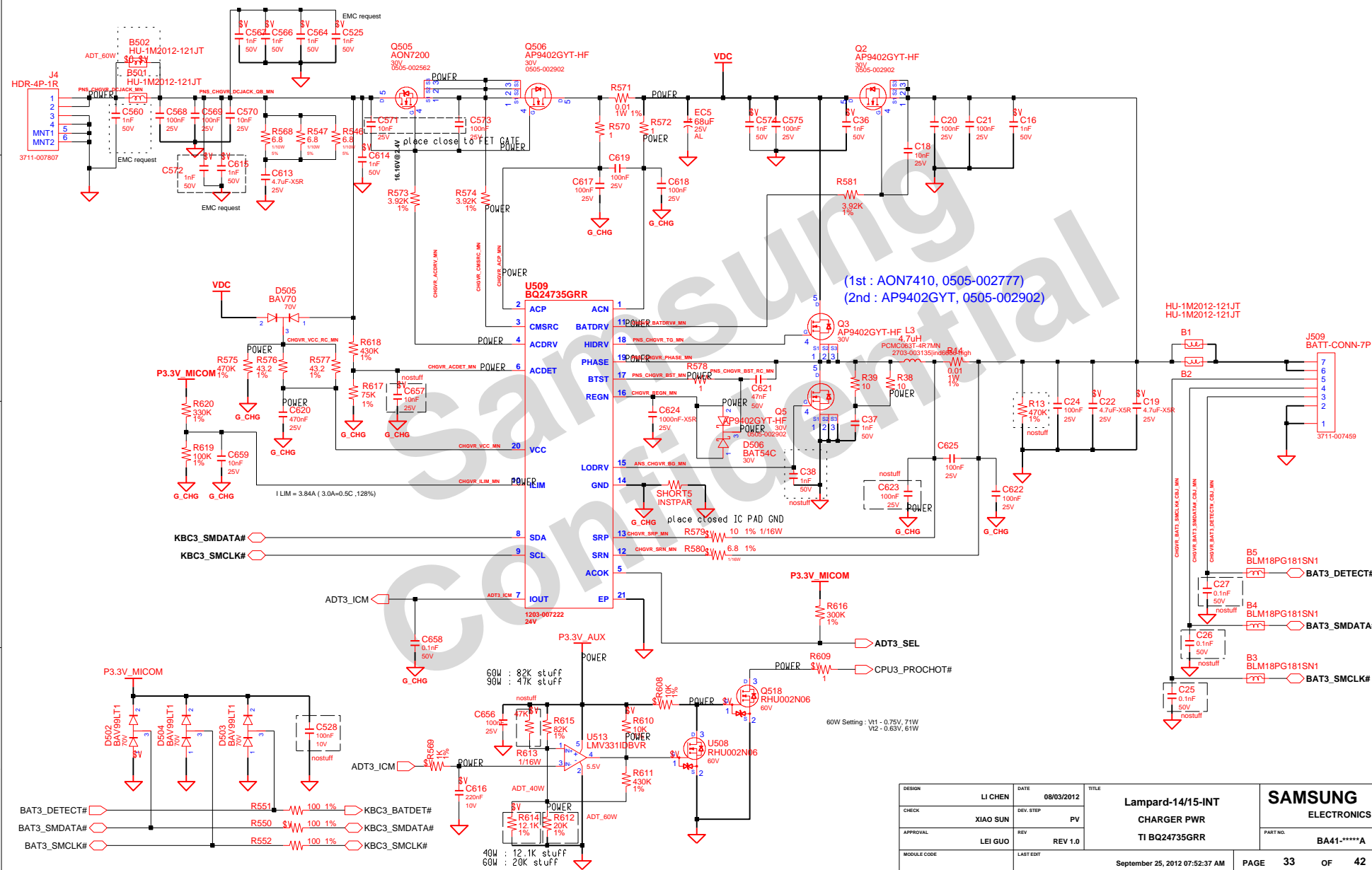

DESIGN	LI CHEN	DATE	08/03/2012	TITLE	Lampard-14/15-INT	SAMSUNG ELECTRONICS
CHECK	XIAO SUN	DEV. STEP	PV		CHARGER PWR	
APPROVAL	LEI GUO	REV	REV 1.0		TI BQ24735GRR	PART NO.
MODULE CODE		LAST EDIT				BA41-****A
					September 25, 2012 07:52:37 AM	PAGE 33 OF 42

SAMSUNG PROPRIETARY
 THIS DOCUMENT CONTAINS CONFIDENTIAL
 PROPRIETARY INFORMATION THAT IS
 SAMSUNG ELECTRONICS CO'S PROPERTY.
 DO NOT DISCLOSE TO OR DUPLICATE FOR OTHERS
 EXCEPT AS AUTHORIZED BY SAMSUNG.

P3.3V_AUX & P5.0V_ALW

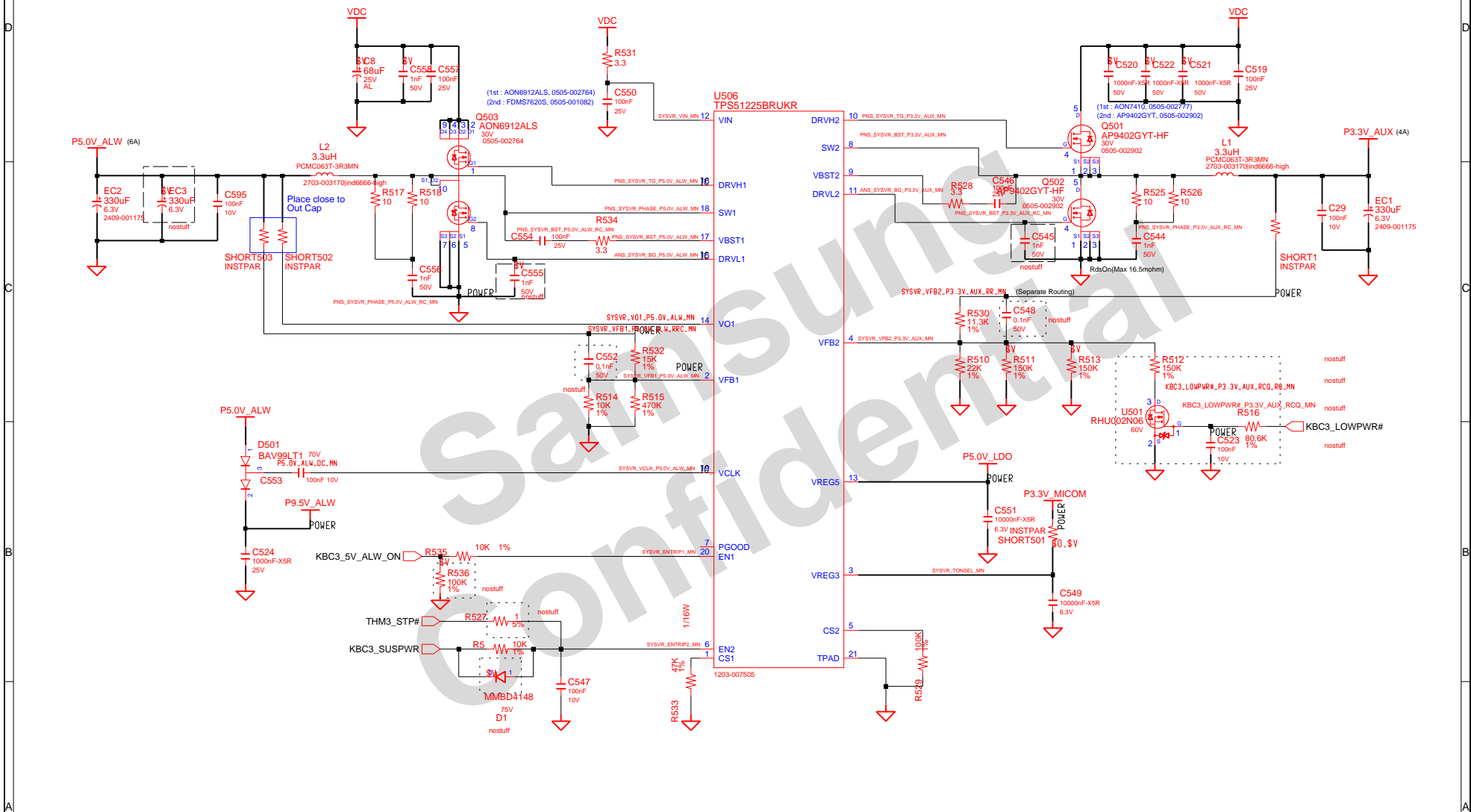

DRAW	LI CHEN	DATE	08/03/2012	TITLE	Lampard-14/15-INT	SAMSUNG ELECTRONICS
CHECK	XIAO SUN	DEV. STEP	PV		P3.3V_AUX & P5.0V_ALW	
APPROVAL	LEI GUO	REV	REV 1.0		P3.3V_AUX & P5.0V_ALW	PART NO. BA41-*****A
MODULE CODE	undefined	LAST EDIT		September 25, 2012 07:52:37 AM	PAGE 34 OF 42	

SAMSUNG PROPRIETARY

THIS DOCUMENT CONTAINS CONFIDENTIAL PROPRIETARY INFORMATION THAT IS SAMSUNG ELECTRONICS CO.'S PROPERTY. DO NOT DISCLOSE TO OR DUPLICATE FOR OTHERS EXCEPT AS AUTHORIZED BY SAMSUNG.

Chipset Power (P1.05V)

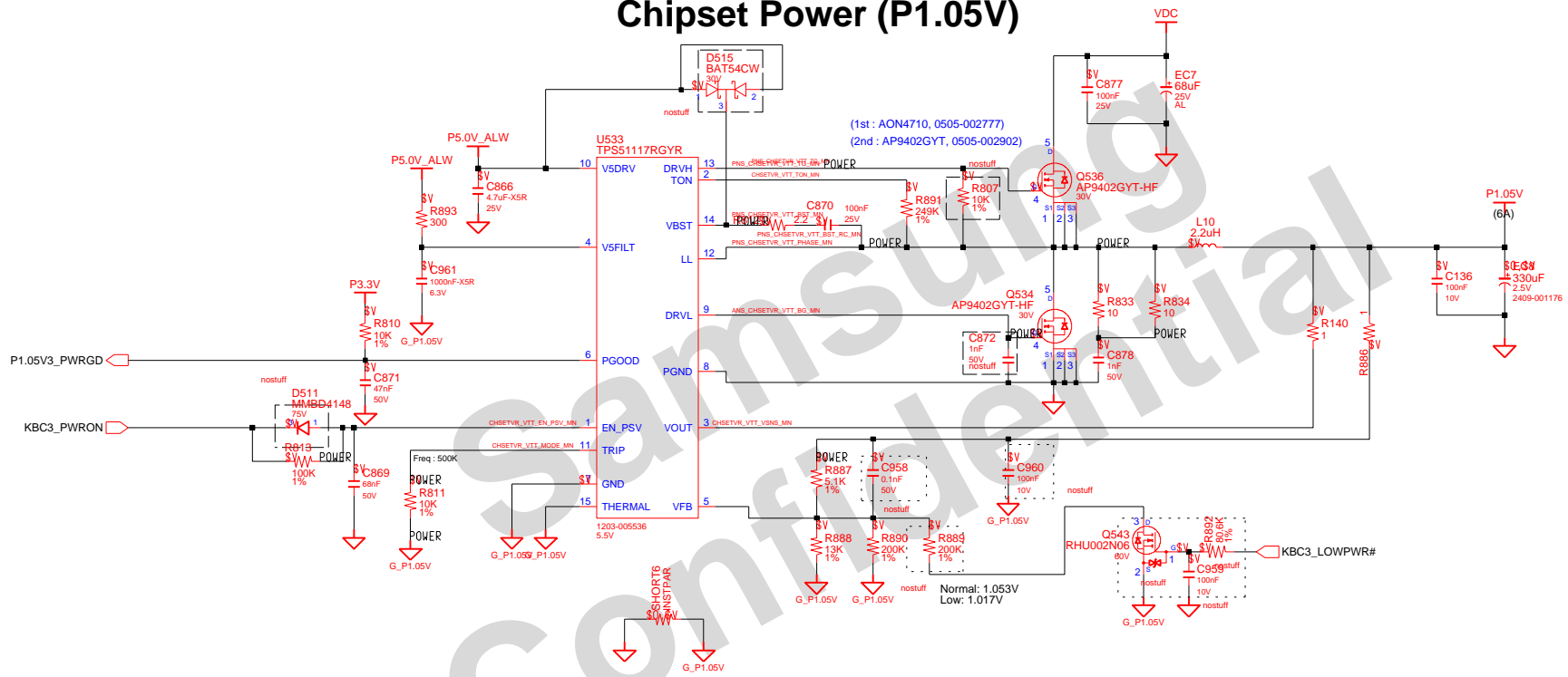

DESIGN	LI CHEN	DATE	08/03/2012	TITLE	Lampard-14/15-INT	SAMSUNG ELECTRONICS
CHECK	XIAO SUN	DEV. STEP	PV	CHIPSET PWR		
APPROVAL	LEI GUO	REV	REV 1.0	P1.05V	PART NO.	BA41-*****A
MODULE CODE		LAST EDIT		September 25, 2012 07:52:37 AM	PAGE	35 OF 42

SAMSUNG PROPRIETARY

THIS DOCUMENT CONTAINS CONFIDENTIAL PROPRIETARY INFORMATION THAT IS SAMSUNG ELECTRONICS CO.'S PROPERTY. DO NOT DISCLOSE TO OR DUPLICATE FOR OTHERS EXCEPT AS AUTHORIZED BY SAMSUNG.

CHIPSET POWER(P1.1V_AUX)

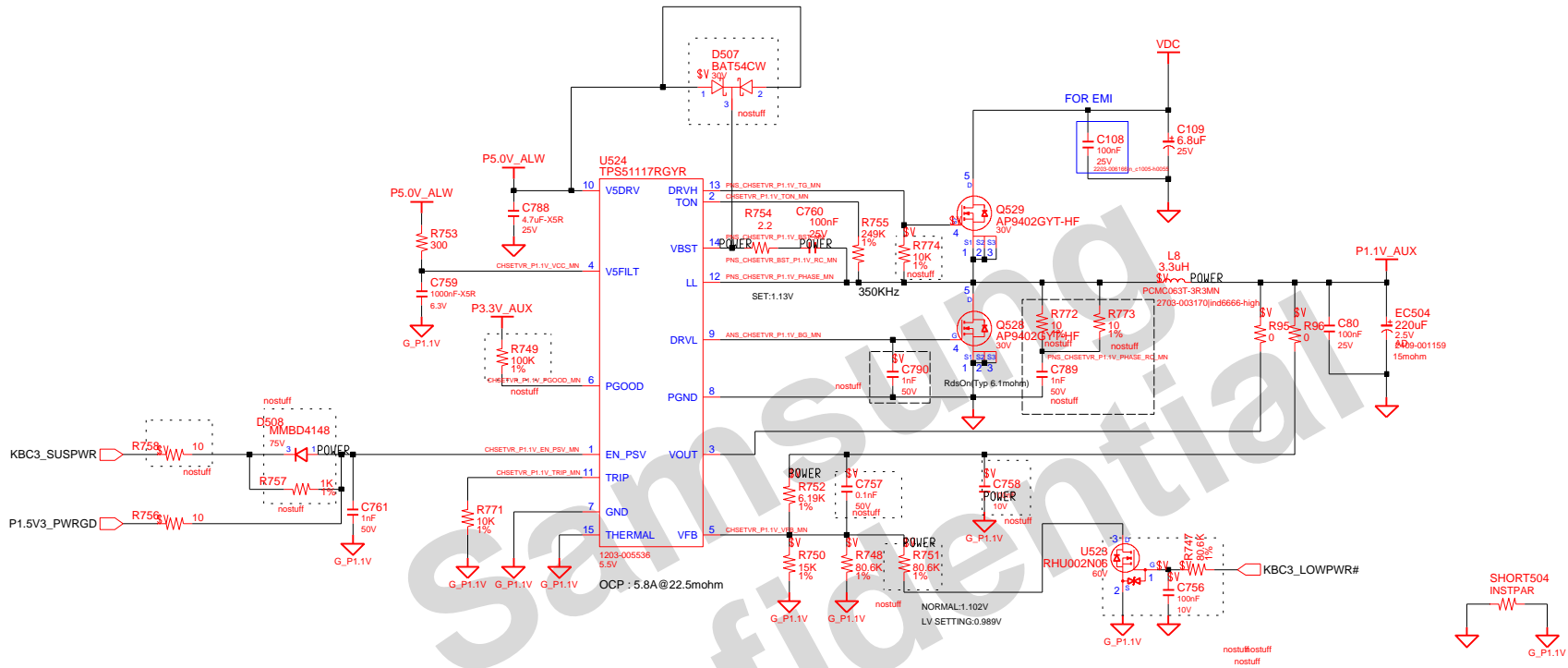

P1.8V (LVDS,PCH Core,LAN , ME IO)

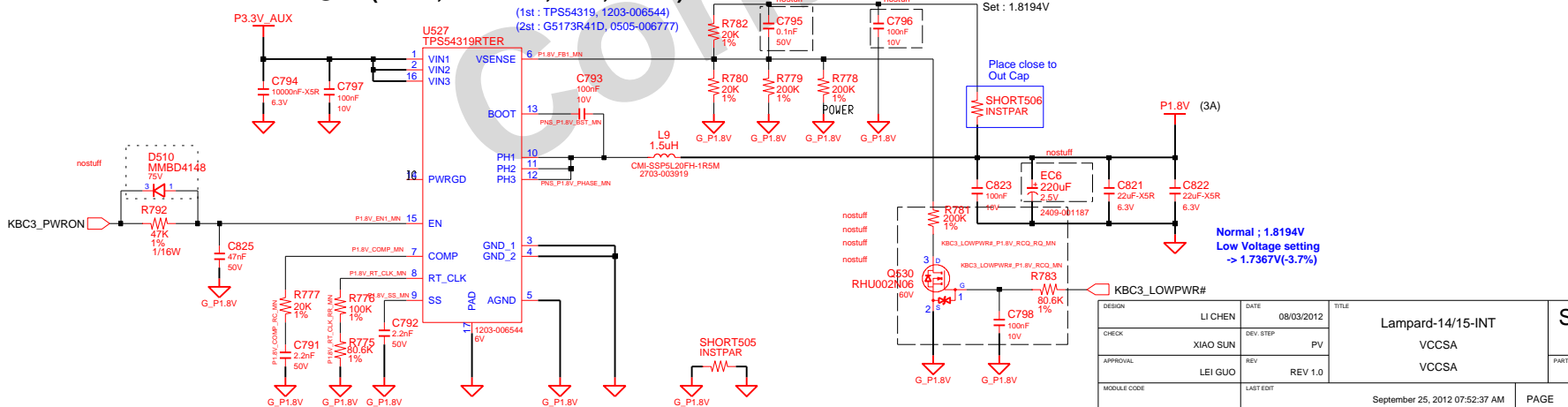

DESIGN	LI CHEN	DATE	08/03/2012	TITLE	Lampard-14/15-INT
CHECK	XIAO SUN	DEV. STEP	PV		VCCSA
APPROVAL	LEI GUO	REV	REV 1.0		VCCSA
MODULE CODE		LAST EDIT			
September 25, 2012 07:52:37 AM				PAGE	36 OF

SAMSUNG
ELECTRONICS
PART NO. BA41-*****A

SAMSUNG PROPRIETARY
 THIS DOCUMENT CONTAINS CONFIDENTIAL
 PROPRIETARY INFORMATION THAT IS
 SAMSUNG ELECTRONICS CO'S PROPERTY.
 DO NOT DISCLOSE TO OR DUPLICATE FOR OTHERS
 EXCEPT AS AUTHORIZED BY SAMSUNG.

CPU VRM [INTERSIL]

VDD Freq = (R_VW & COMP / 2.33 + 0.29) uS
 : 342.6KHz@6.8Kohm

VDD_NB Freq = 1 / ((1.5*10^-6) * Rfsetnb) Hz
 : 303KHz@22Kohm

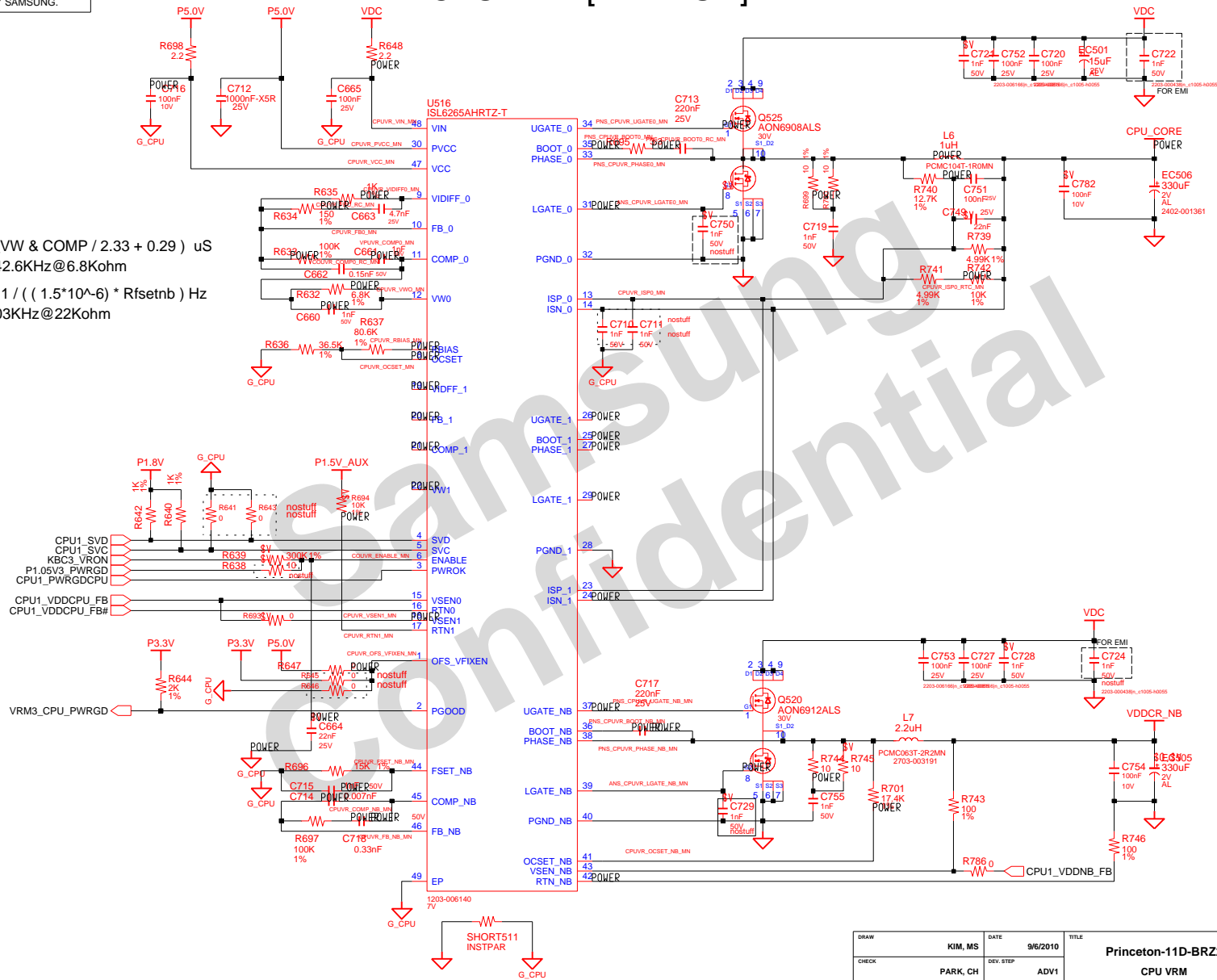

DRAW	KIM, MS	DATE	9/6/2010	TITLE	Princeton-11D-BR22	SAMSUNG ELECTRONICS
CHECK	PARK, CH	DEV. STEP	ADV1		CPU VRM	
APPROVAL	CHO, KS	REV	REV 0.23		ISL6265AHRZ-T	PART NO. BA41-####A
MODULE CODE		LAST EDIT			February 28, 2012 13:33:37 PM	PAGE 36 OF 40

SAMSUNG PROPRIETARY

THIS DOCUMENT CONTAINS CONFIDENTIAL PROPRIETARY INFORMATION THAT IS SAMSUNG ELECTRONICS CO.'S PROPERTY. DO NOT DISCLOSE TO OR DUPLICATE FOR OTHERS EXCEPT AS AUTHORIZED BY SAMSUNG.

Switched Power

Switched Power On (P3.3V) Multi@AP2607GY

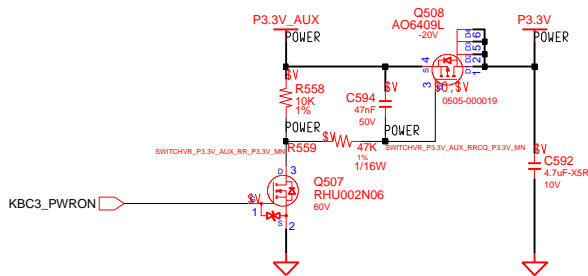

Switched Power On (P1.1V)

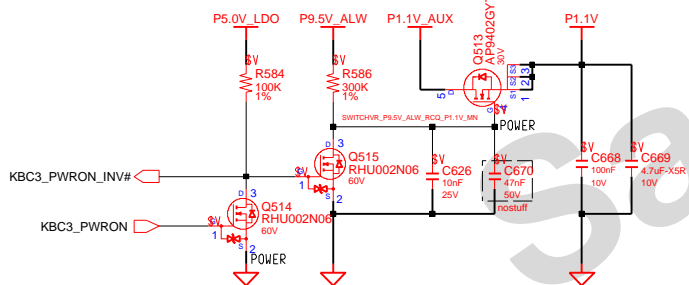

Switched Power On (P5.0V)

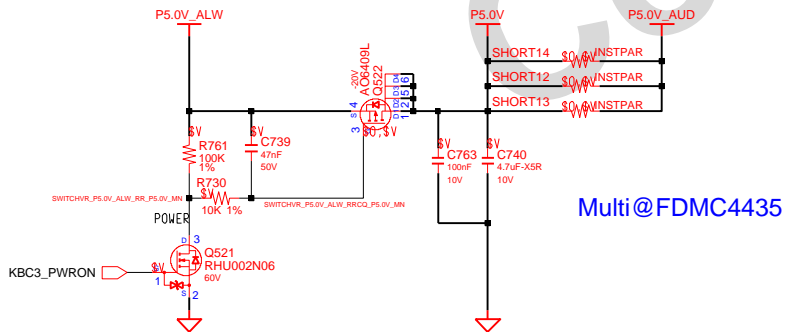

Multi@FDMC4435

DRAW	LI CHEN	DATE	08/03/2012	TITLE	Lampard-14/15-INT	SAMSUNG ELECTRONICS
CHECK	XIAO SUN	DEV. STEP	PV	PWR_MV_SWITCHED		
APPROVAL	LEI GUO	REV	REV 1.0	SWITCHED POWER		PART NO. BA41-*****A
MODULE CODE		LAST EDIT		September 25, 2012 07:52:37 AM	PAGE	39 OF 42

SAMSUNG PROPRIETARY

THIS DOCUMENT CONTAINS CONFIDENTIAL PROPRIETARY INFORMATION THAT IS SAMSUNG ELECTRONICS CO.'S PROPERTY. DO NOT DISCLOSE TO OR DUPLICATE FOR OTHERS EXCEPT AS AUTHORIZED BY SAMSUNG.

POWER DISCHARGER

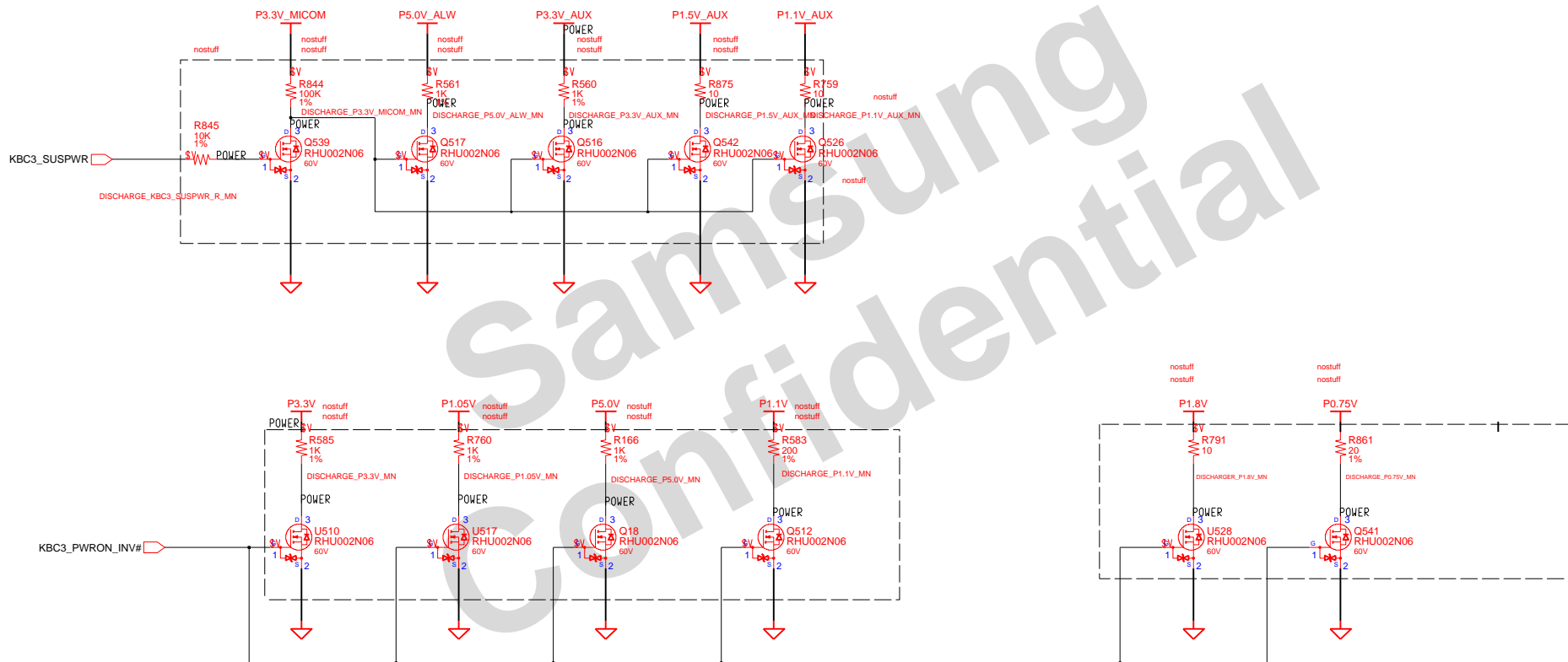

DRAW	LI CHEN	DATE	08/03/2012	TITLE	Lampard-14/15-INT PWR_MV_DISCHARGER DISCHARGING LOGIC	SAMSUNG ELECTRONICS
CHECK	XIAO SUN	DEV. STEP	PV			
APPROVAL	LEI GUO	REV	REV 1.0			PART NO. BA41-*****A
MODULE CODE	undefined	LAST EDIT	September 25, 2012 07:52:37 AM	PAGE	40	OF 42

SAMSUNG PROPRIETARY

THIS DOCUMENT CONTAINS CONFIDENTIAL PROPRIETARY INFORMATION THAT IS SAMSUNG ELECTRONICS CO.'S PROPERTY. DO NOT DISCLOSE TO OR DUPLICATE FOR OTHERS EXCEPT AS AUTHORIZED BY SAMSUNG.

TP SUB BOARD

TOUCHPAD

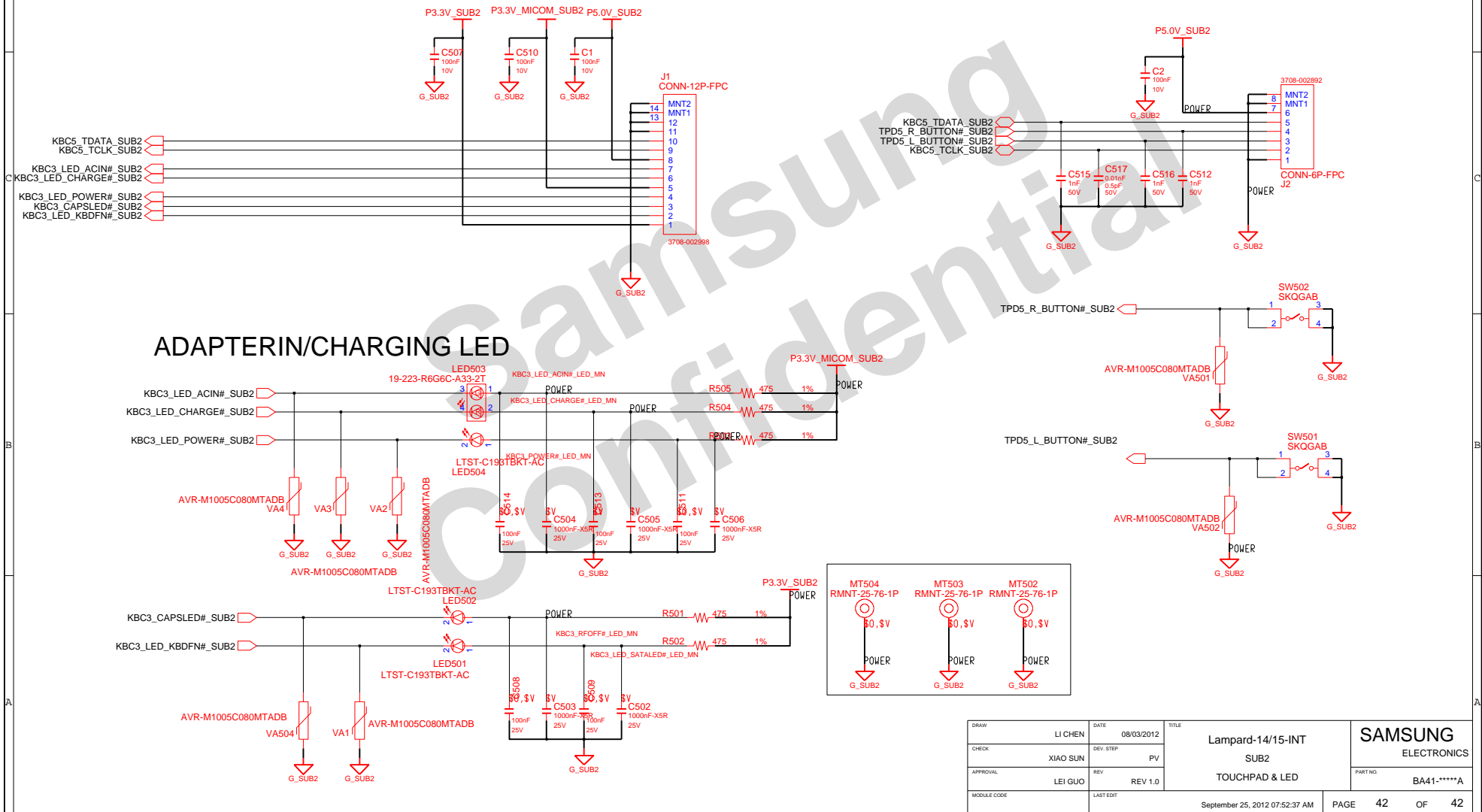

DRAW	LI CHEN	DATE	08/03/2012	TITLE	Lampard-14/15-INT	SAMSUNG ELECTRONICS
CHECK	XIAO SUN	DEV. STEP	PV		SUB2	
APPROVAL	LEI GUO	REV	REV 1.0		TOUCHPAD & LED	PART NO. BA41-*****A
MODULE CODE		LAST EDIT		September 25, 2012 07:52:37 AM	PAGE	42 OF 42