

# VIETMOBILE.VN

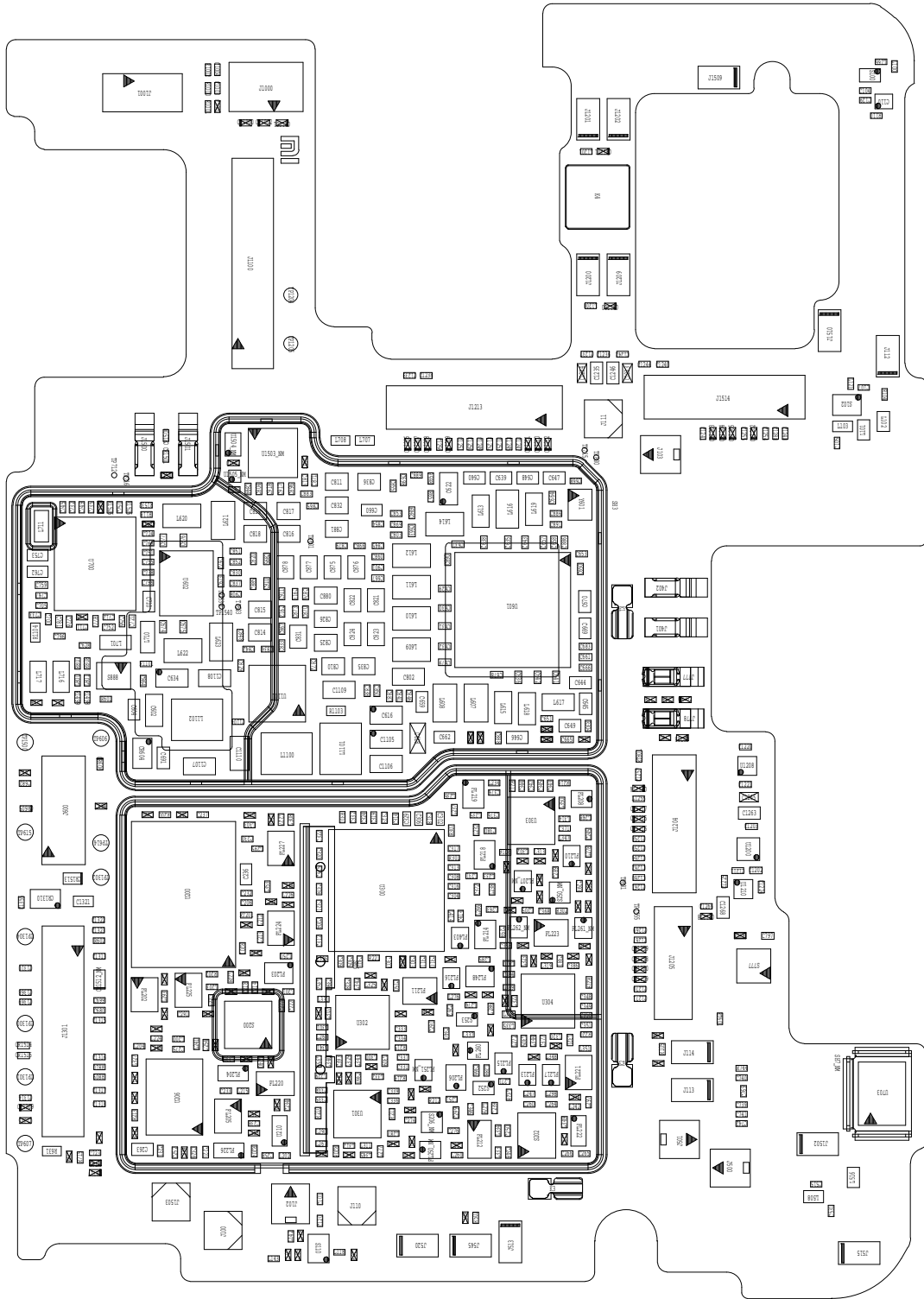

# VIETMOBILE.VN

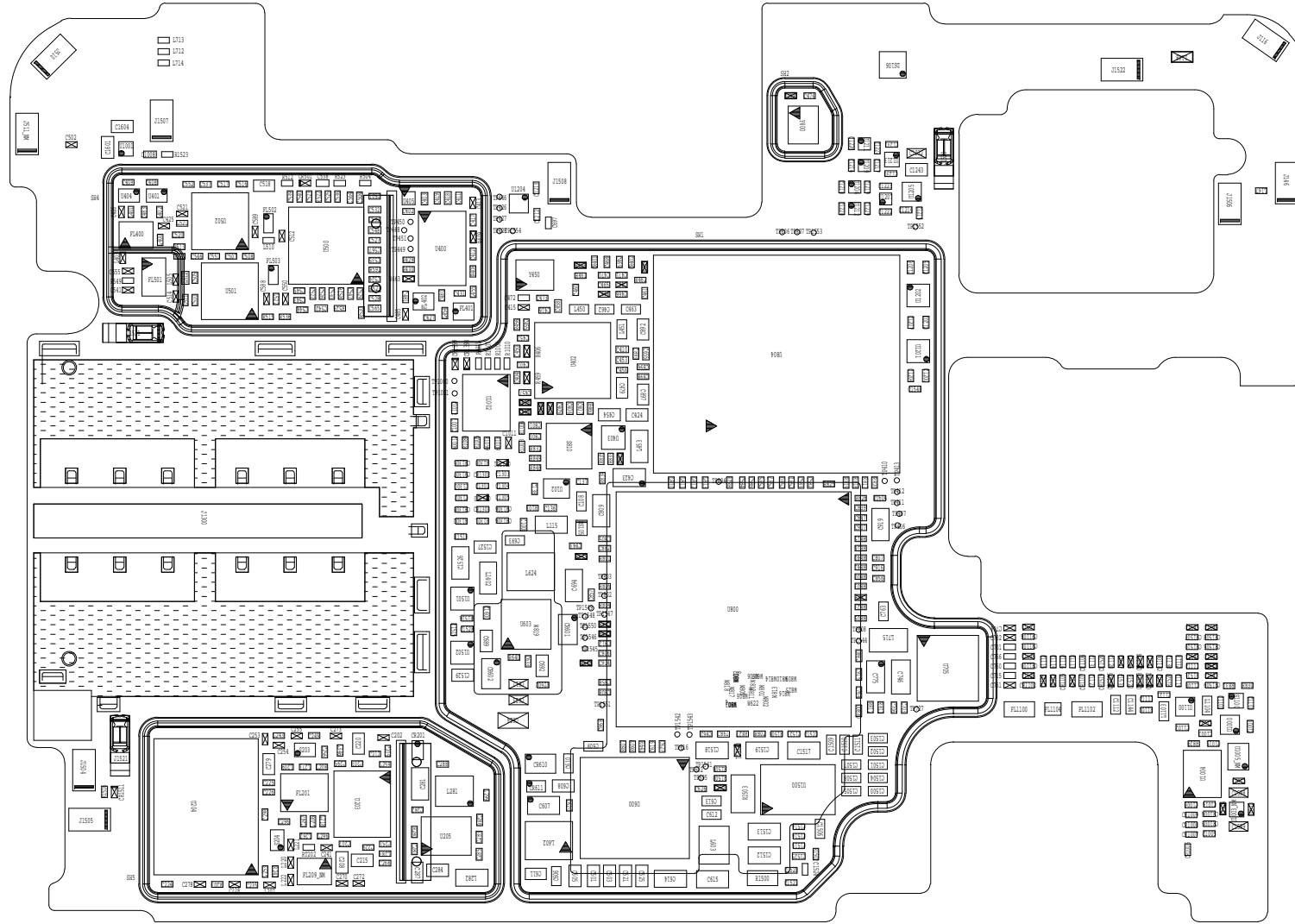

# DRX\_ANT

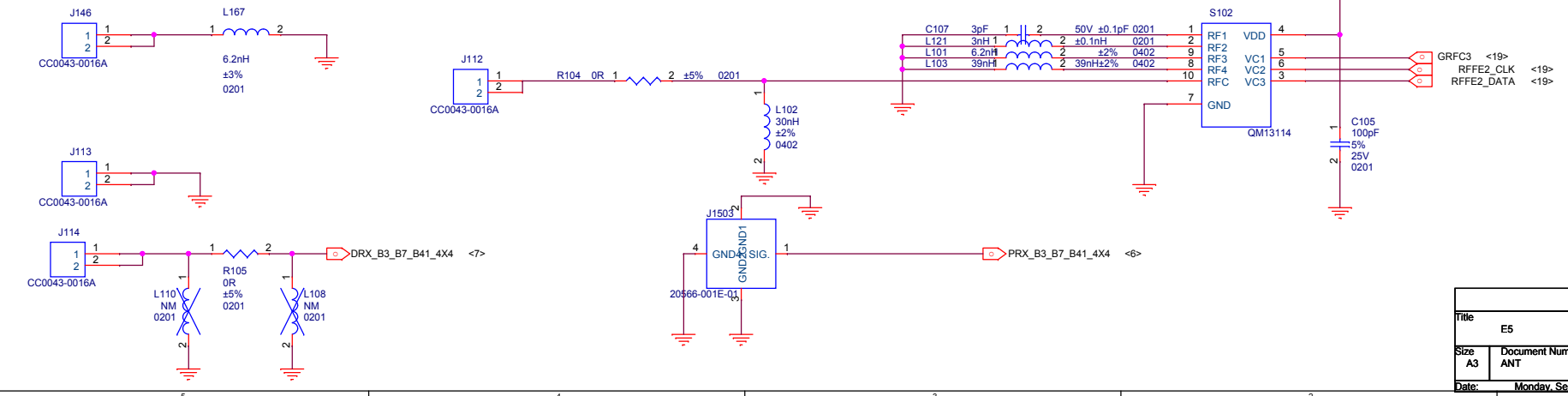
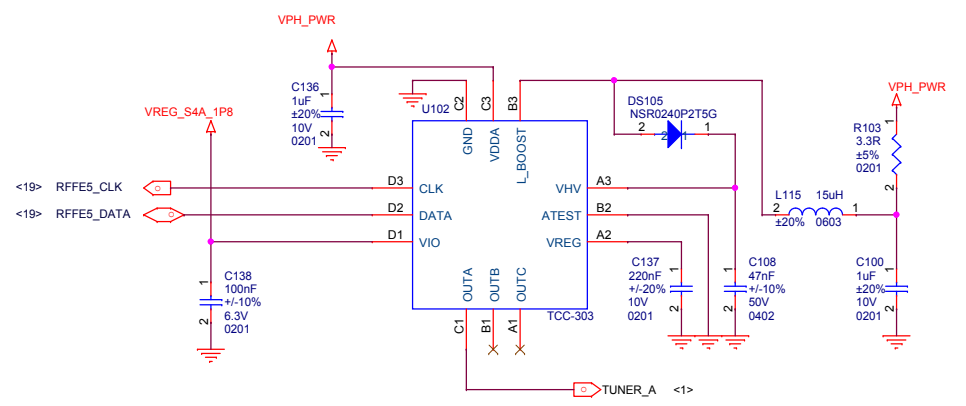
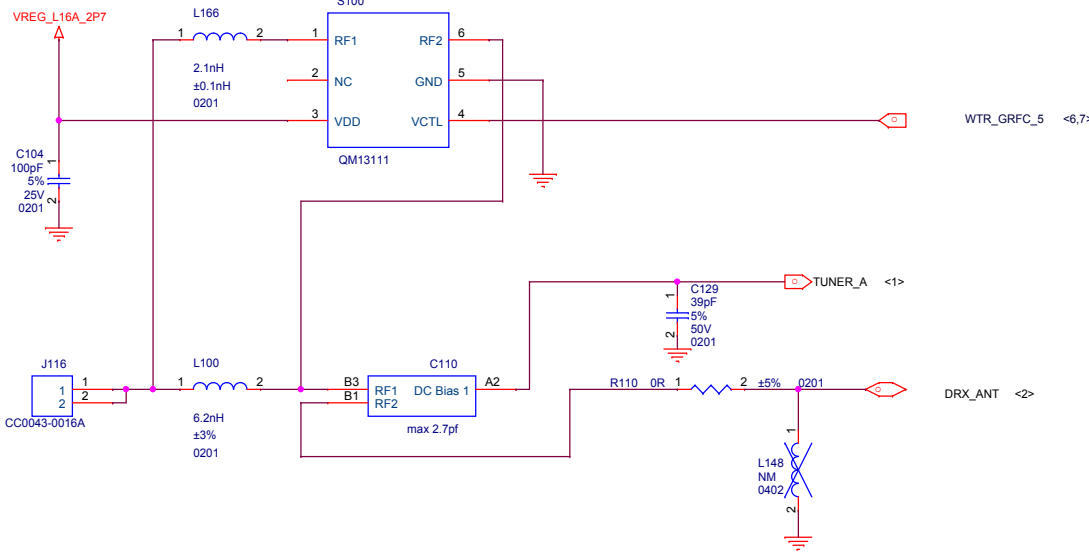

Title		
E5		
Size	Document Number	Rev
A3	ANT	
Date:	Monday, September 03, 2018	Sheet 1 of 45

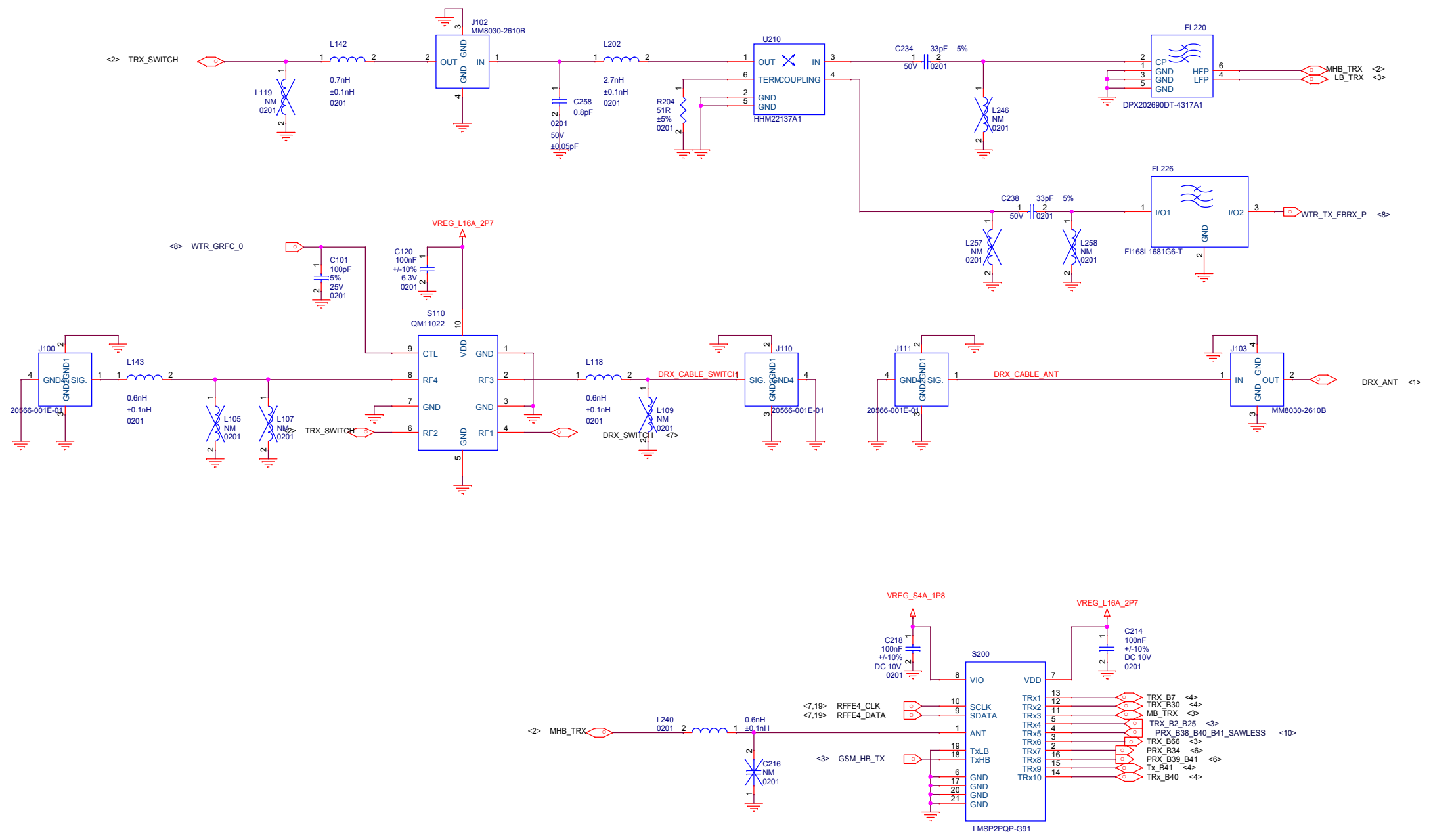

Title		E5
Size	Document Number	COUPLER&SWITCH
Date:	Monday, September 03, 2018	Sheet 2 of 45

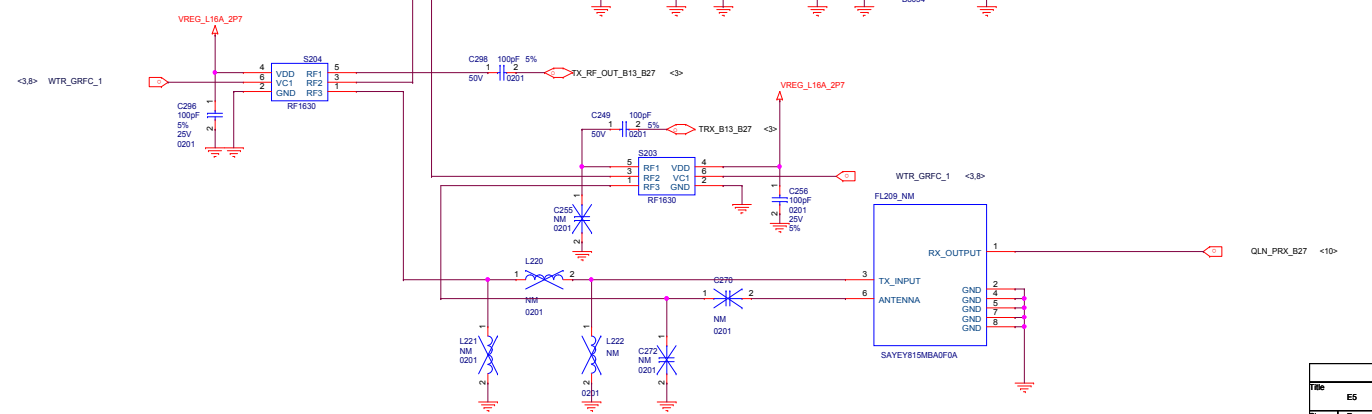
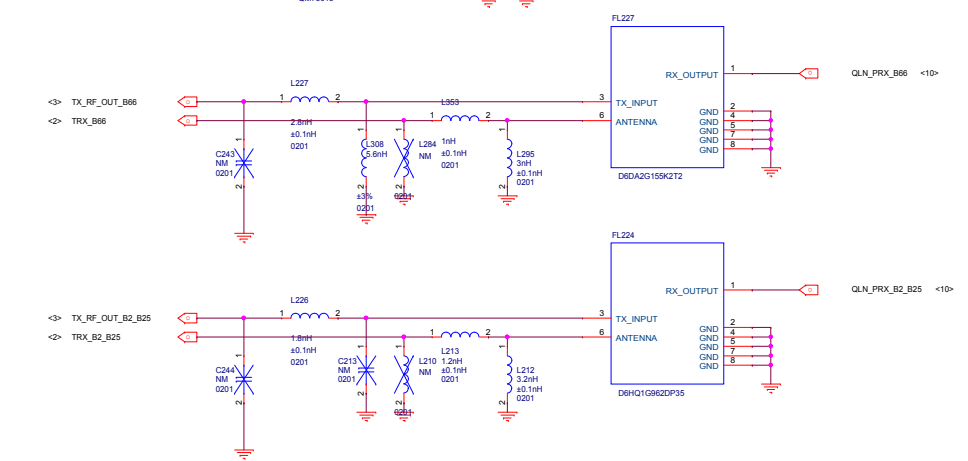
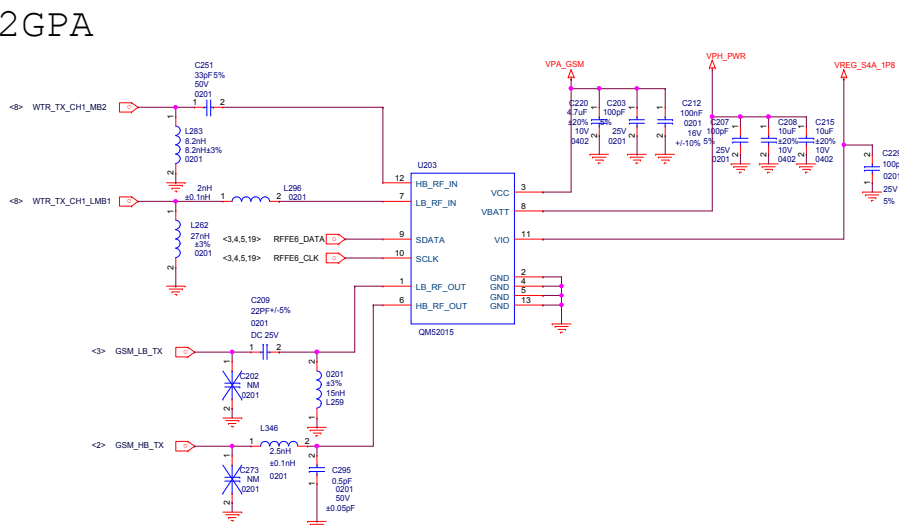
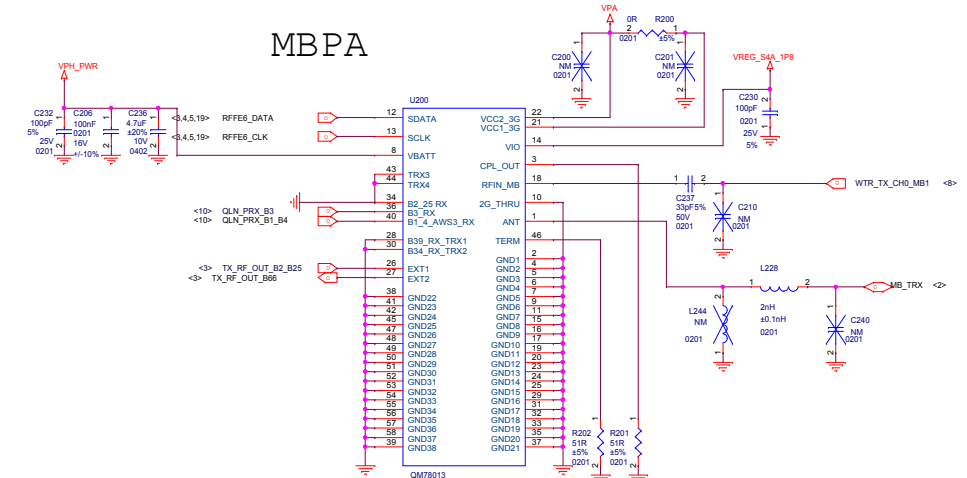
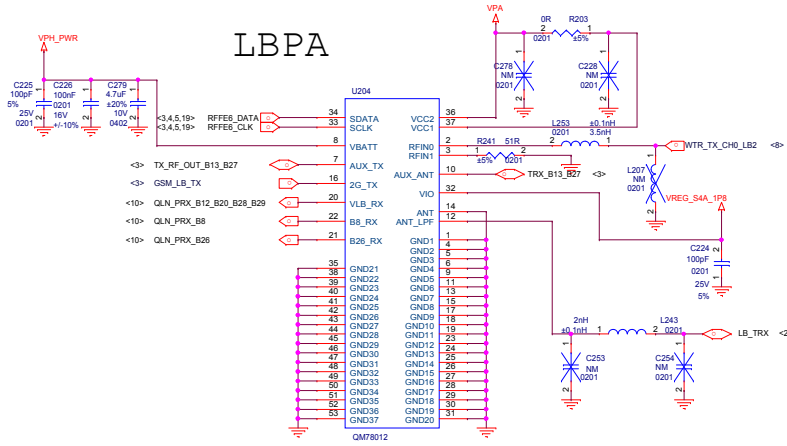

File	E5		
Size	Document Number	Rev	
A2	LM_PA_MID_2GPA		
Date:	Monday, September 03, 2018	Sheet	3 of 46

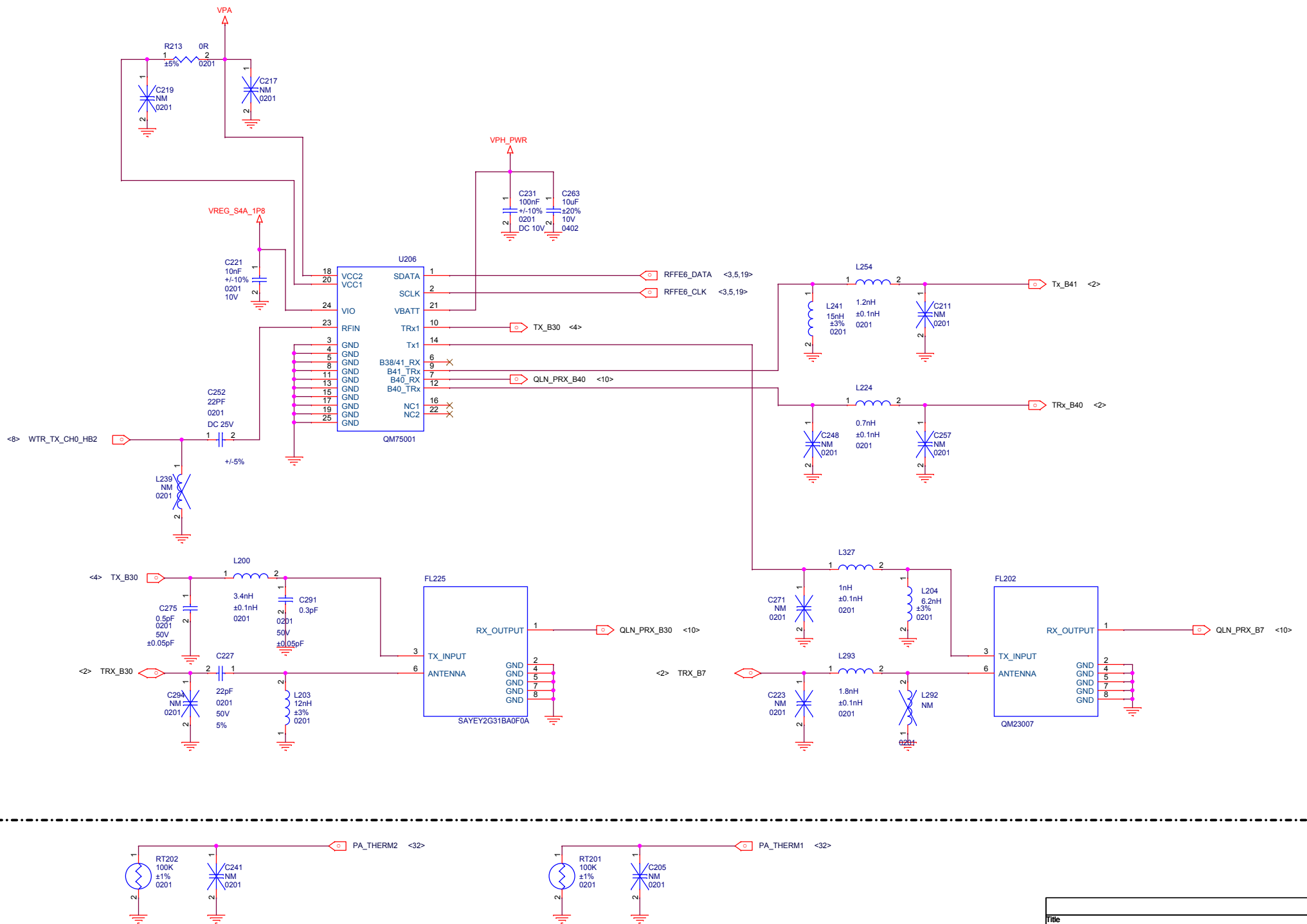

Title		
E5		
Size	Document Number	Rev
A3	HBPA	
Date:	Monday, September 03, 2018	Sheet 4 of 45

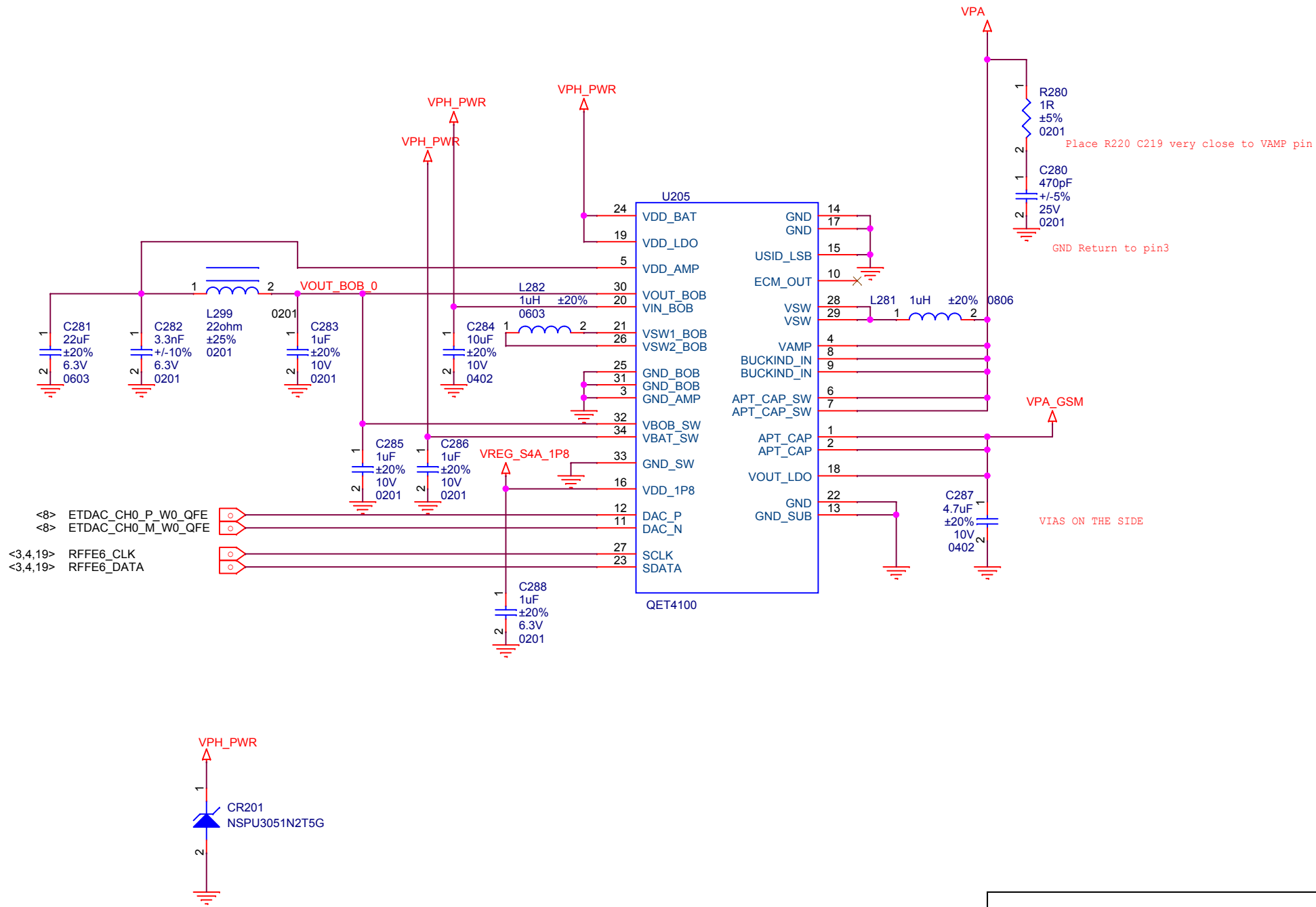

Title		
E5		
Size	Document Number	Rev
A4	QFE4100	
Date:	Monday, September 03, 2018	Sheet 5 of 45

PRX B34 B39 B41

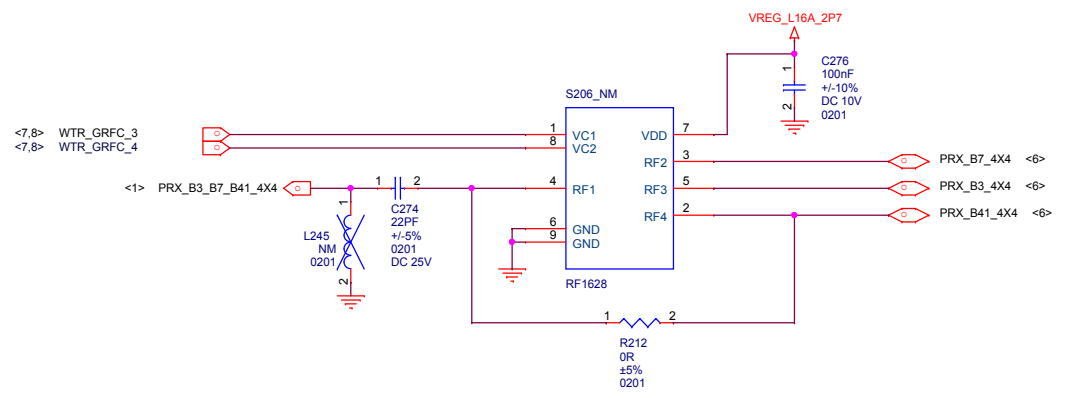
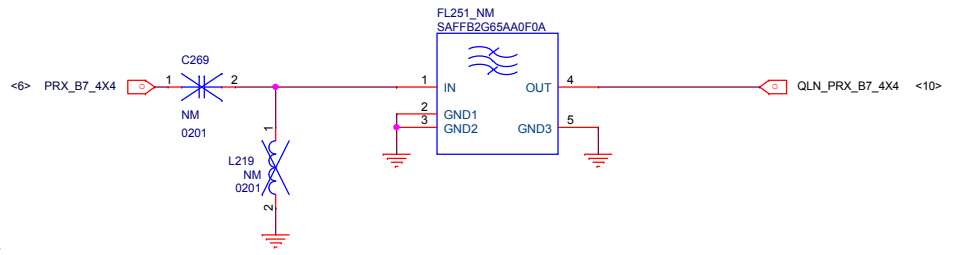
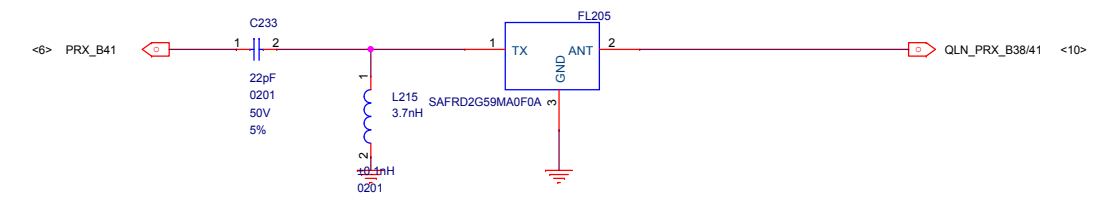
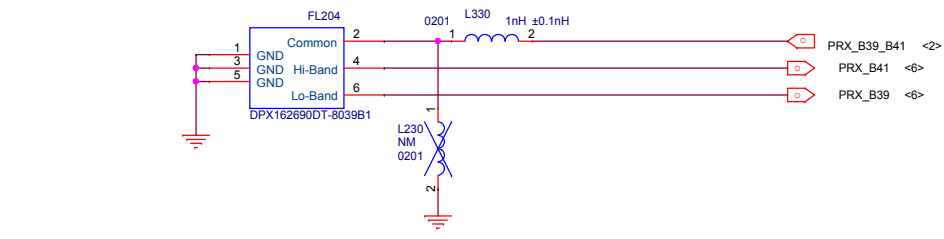
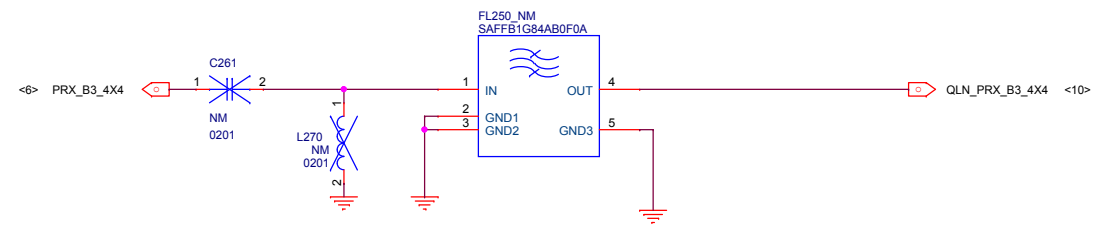
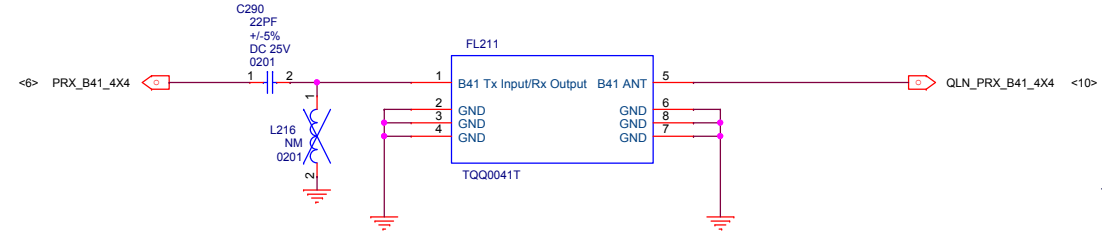
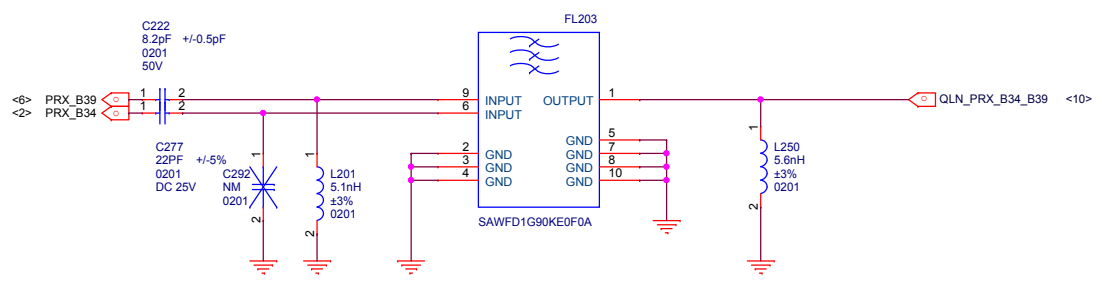

Title		
E5		
Size	Document Number	Rev
A3	PRX	
Date:	Monday, September 03, 2018	Sheet 6 of 45



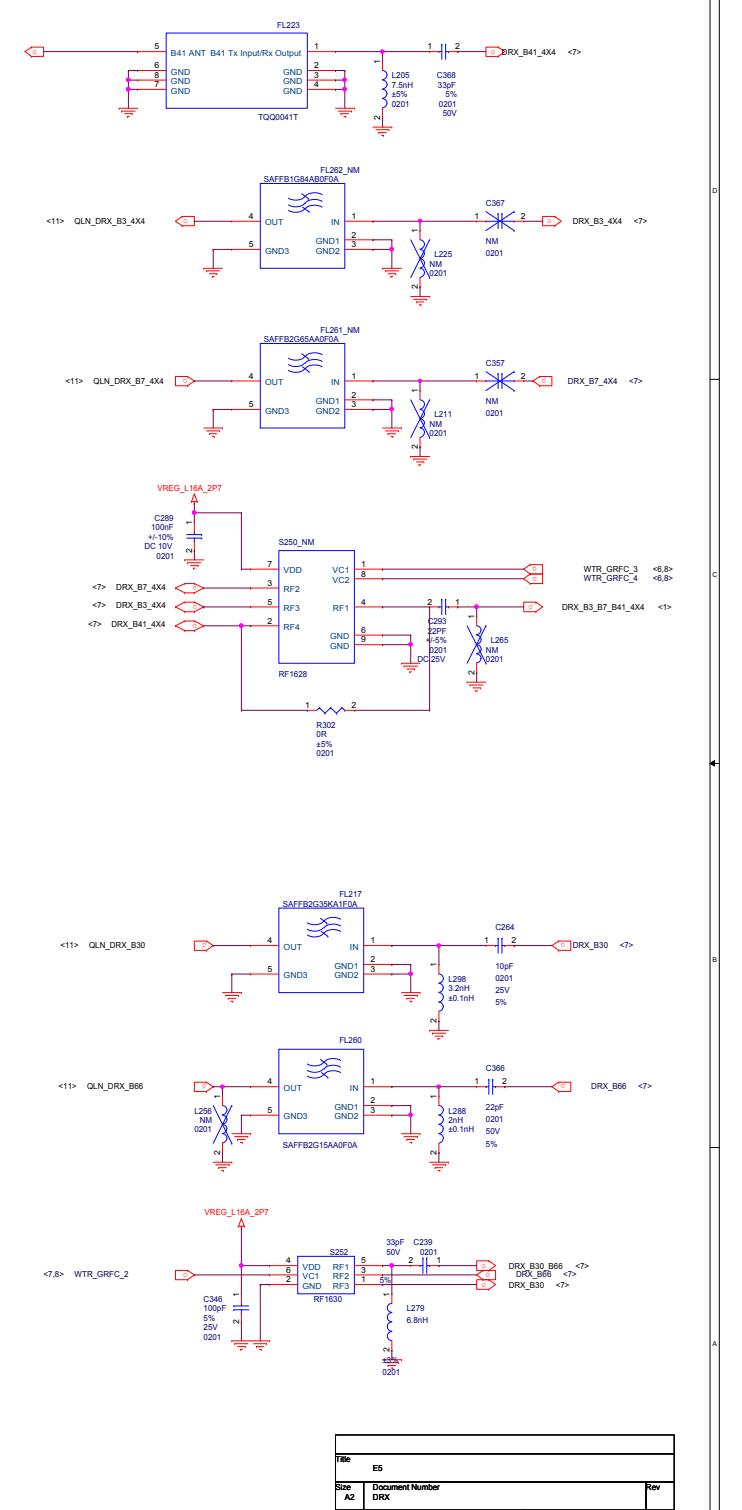
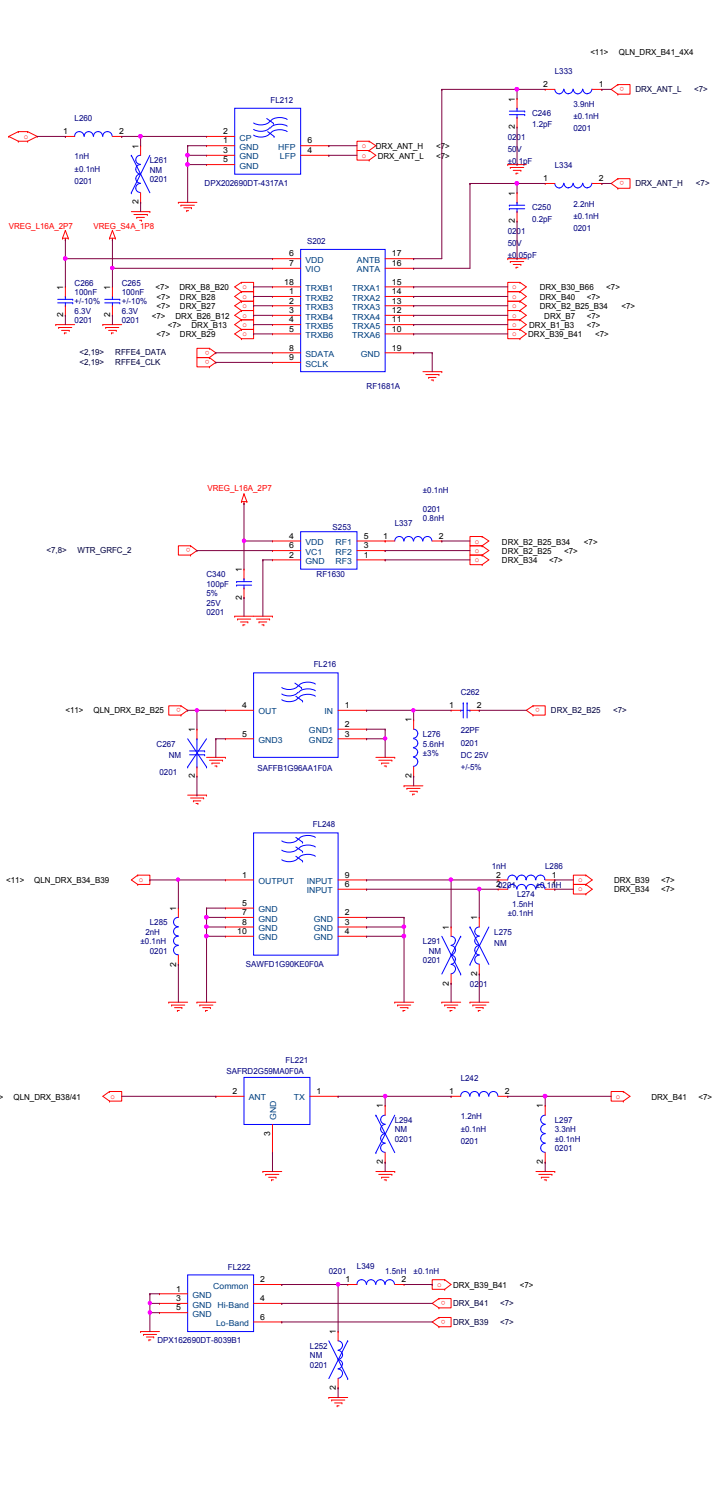
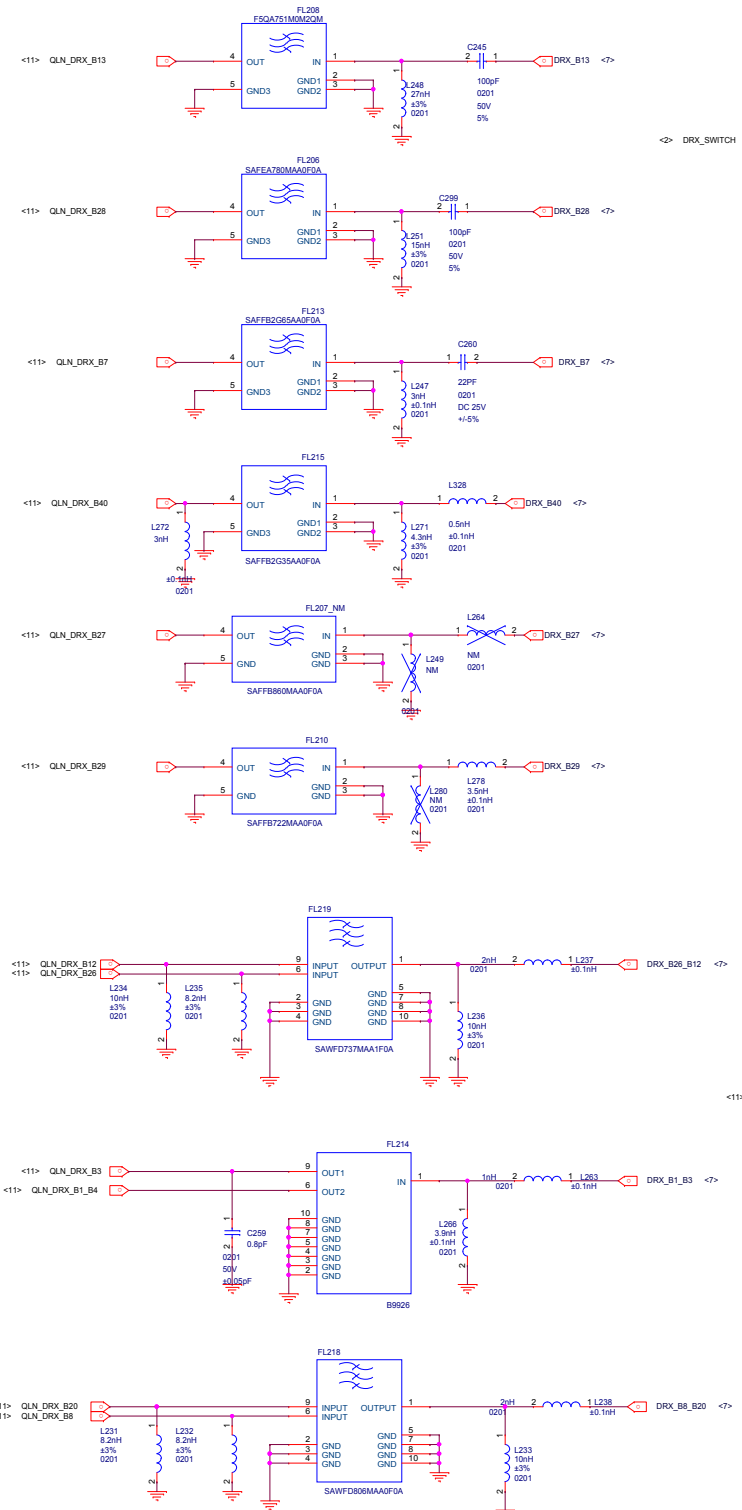

File	E5		Rev
Size	Document Number		
A2	DRX		
Date:	Monday, September 03, 2018	Sheet	7 of 45

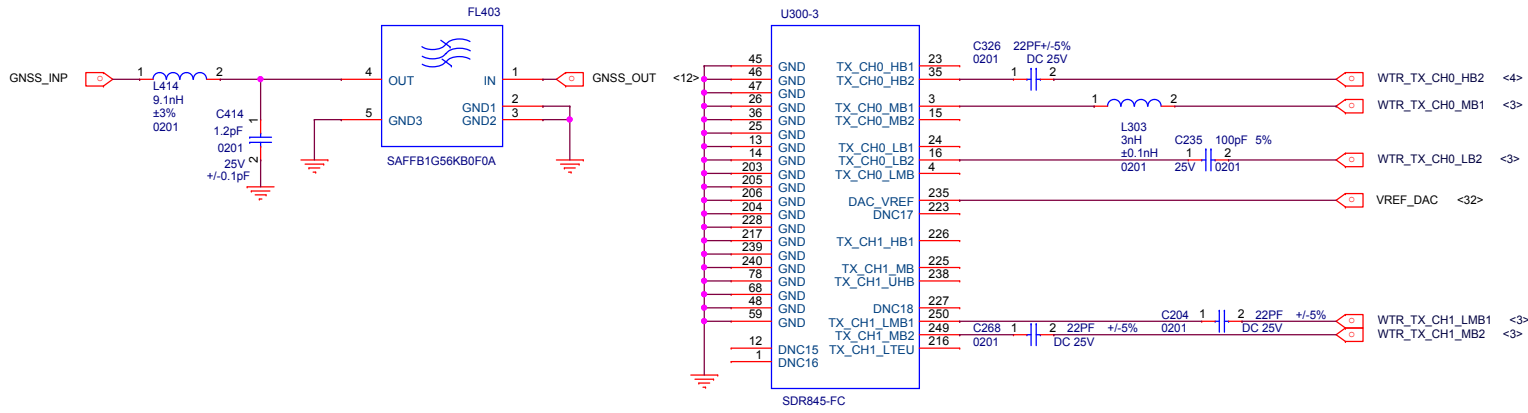
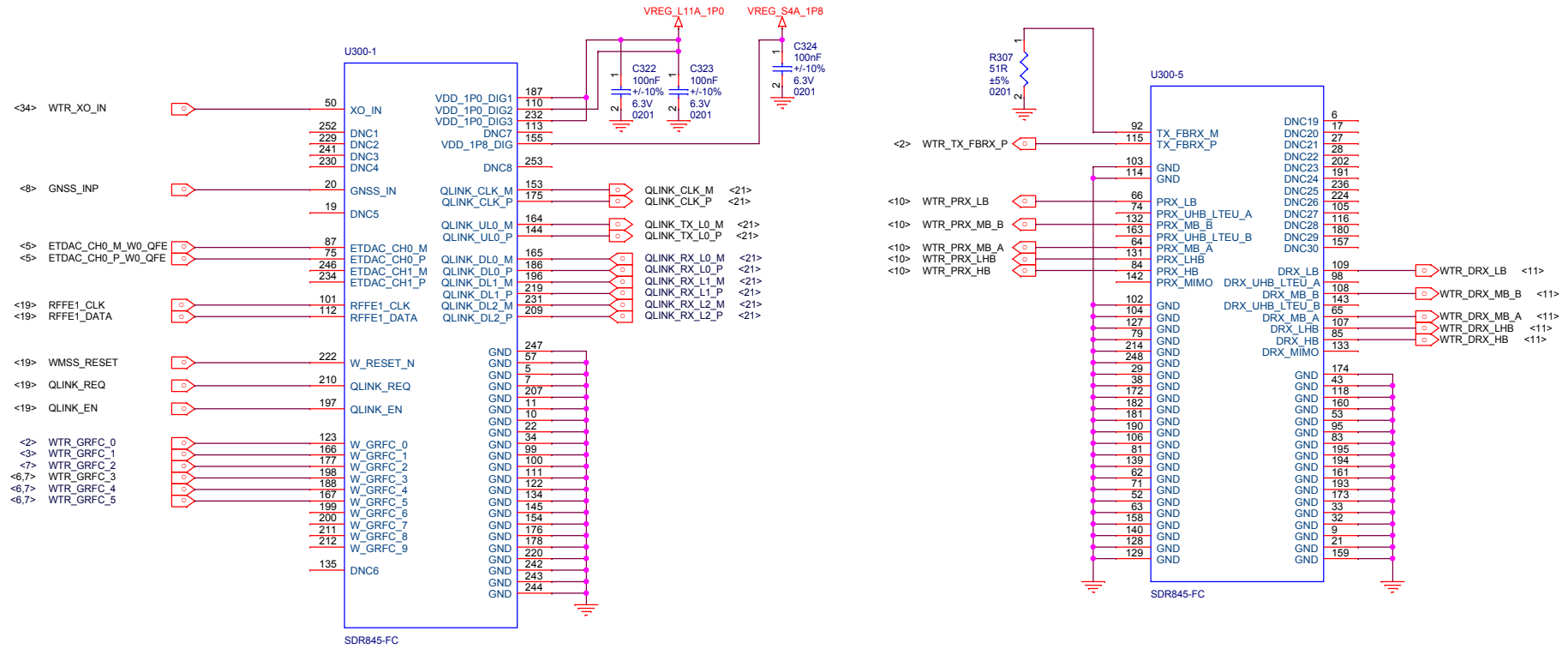

Title		
E5		
Size	Document Number	Rev
A3	WTR5975 MSS	
Date:	Monday, September 03, 2018	Sheet 8 of 45

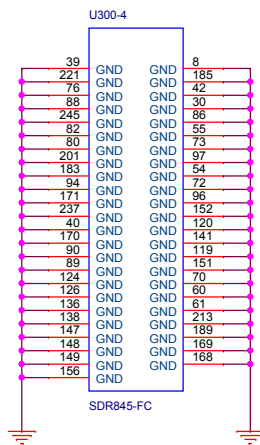
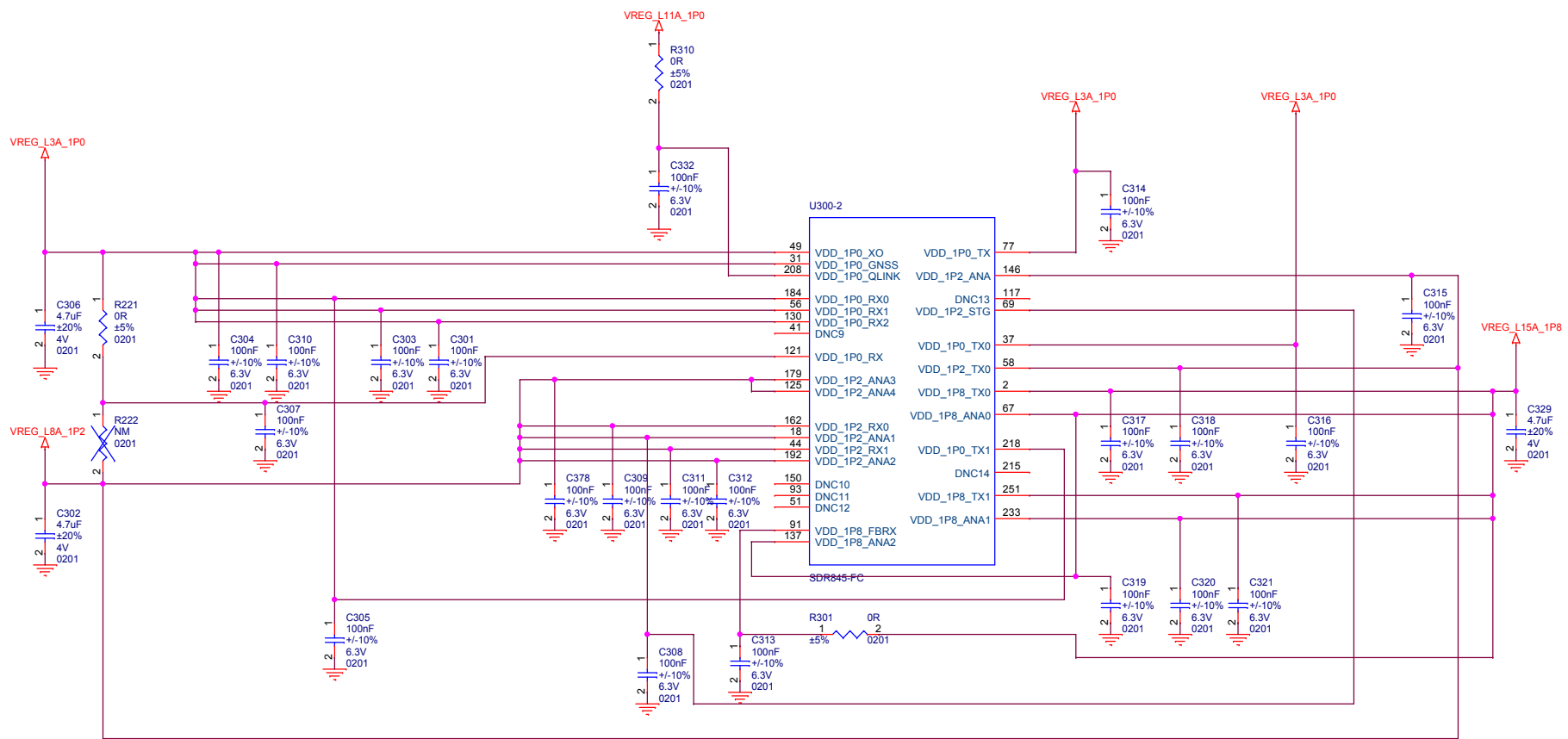

Title		
E5		
Size	Document Number	Rev
A3	WTR5975 POWER	P1B
Date:	Monday, September 03, 2018	Sheet 9 of 45

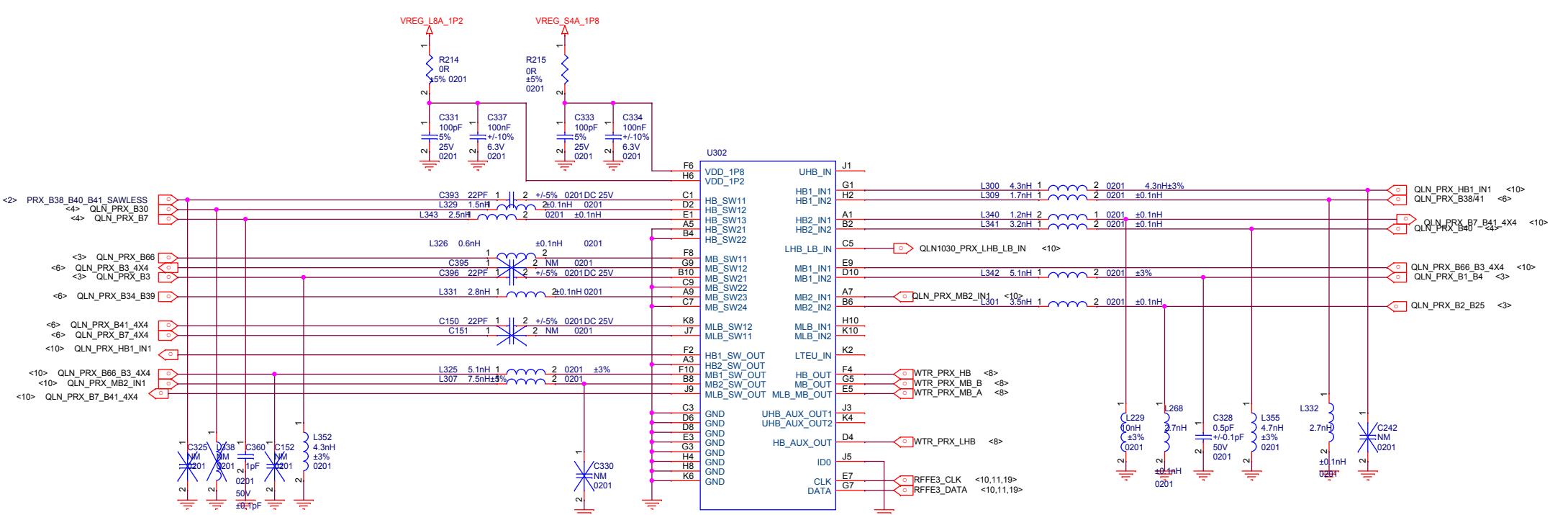
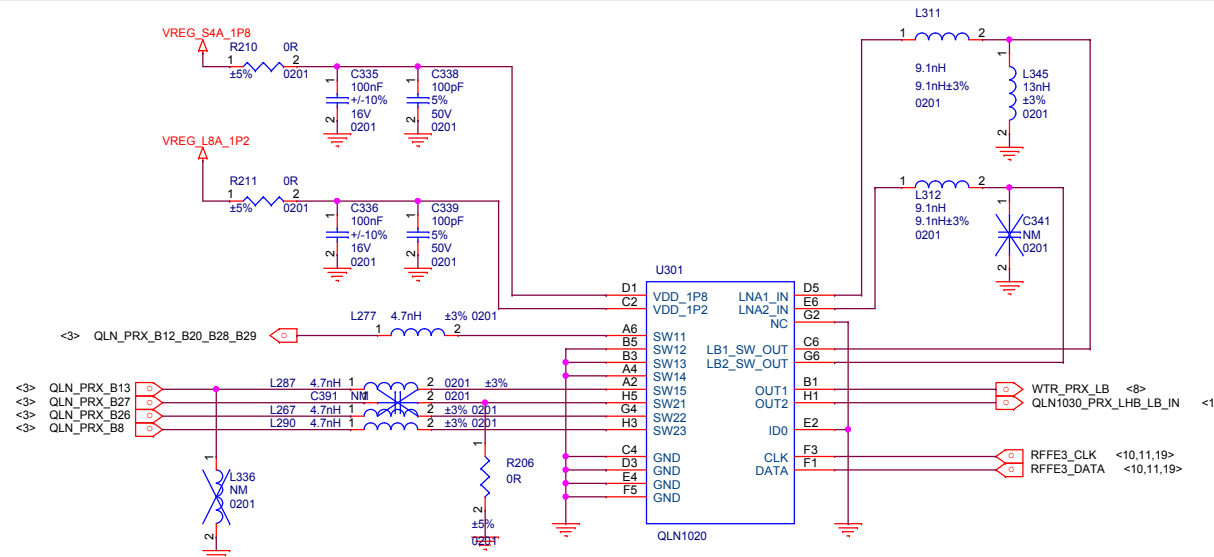

Title			E5
Size	Document Number	Rev	
A3	QLN PRX	P1B	
Date:	Monday, September 03, 2018	Sheet	10 of 45

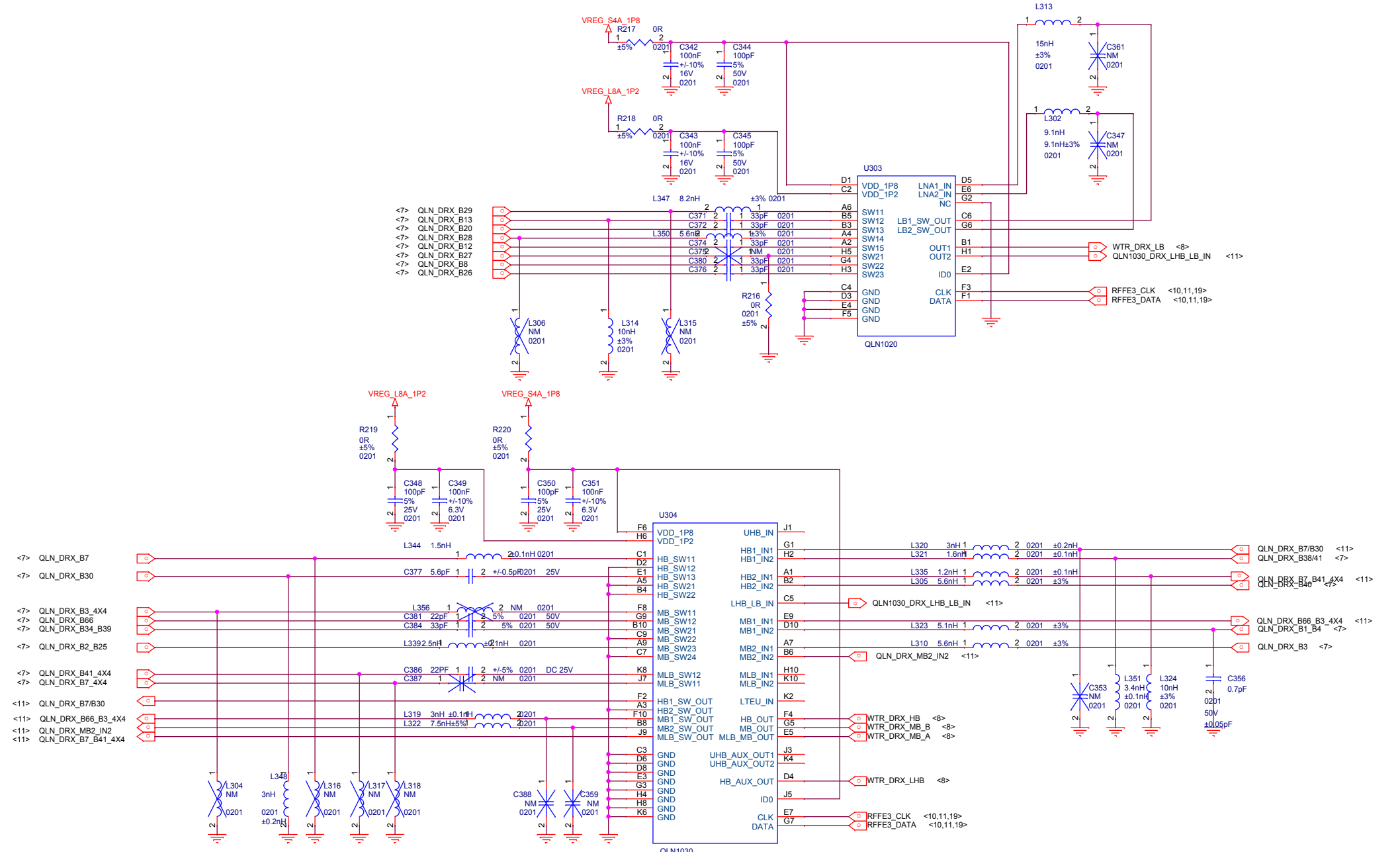

Title		
E5		
Size	Document Number	Rev
A3	QLN DRX	P1B
Date:	Monday, September 03, 2018	Sheet 11 of 45

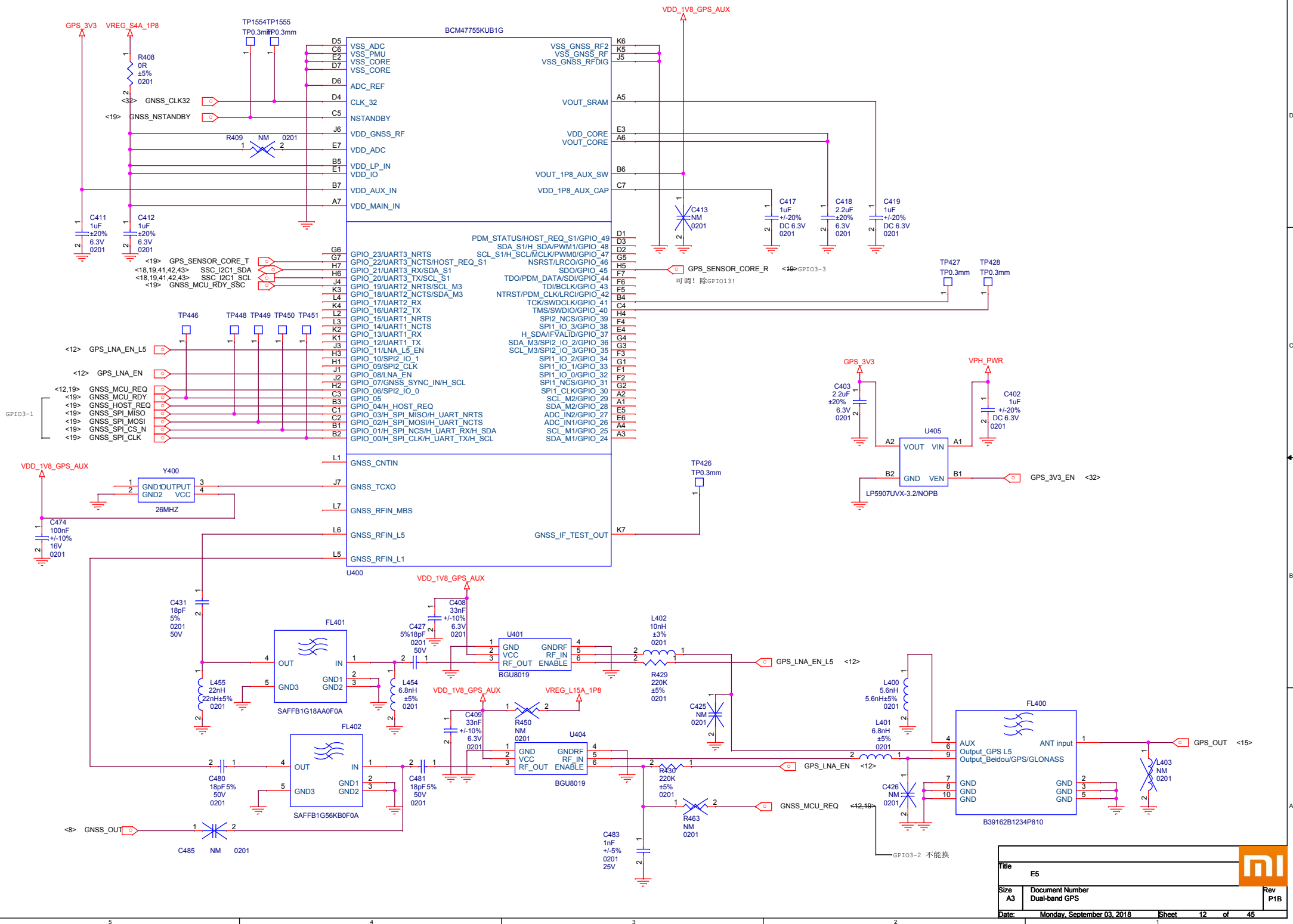

Title		E5	
Size	A3	Document Number	Dual-band GPS
Date:	Monday, September 03, 2018	Sheet	12 of 45

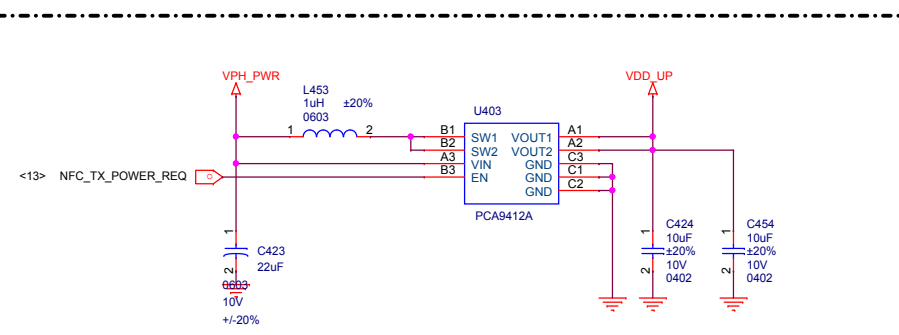
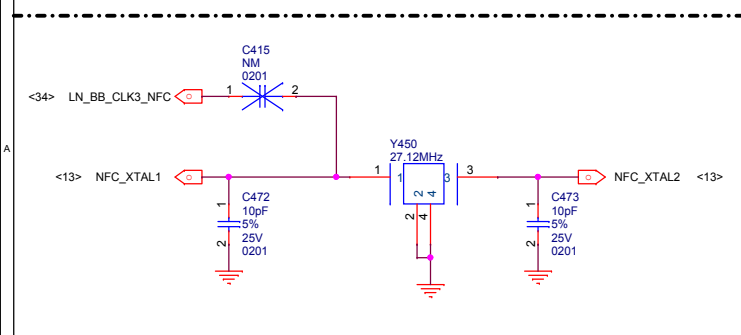
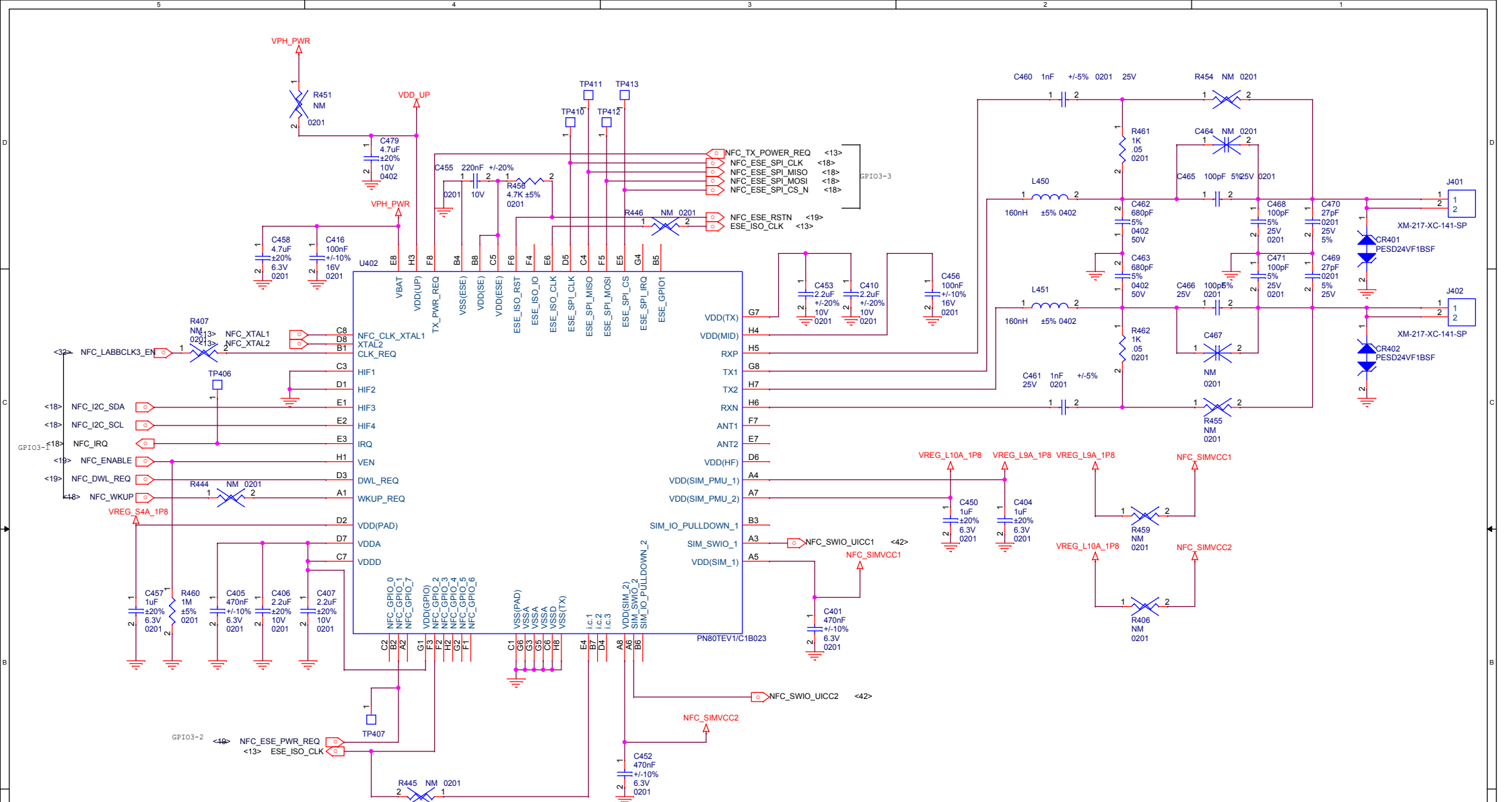

Title		E5	
Size	Document Number	NFC	
Date:	Monday, September 03, 2018	Sheet	13 of 45
Rev	P1B		

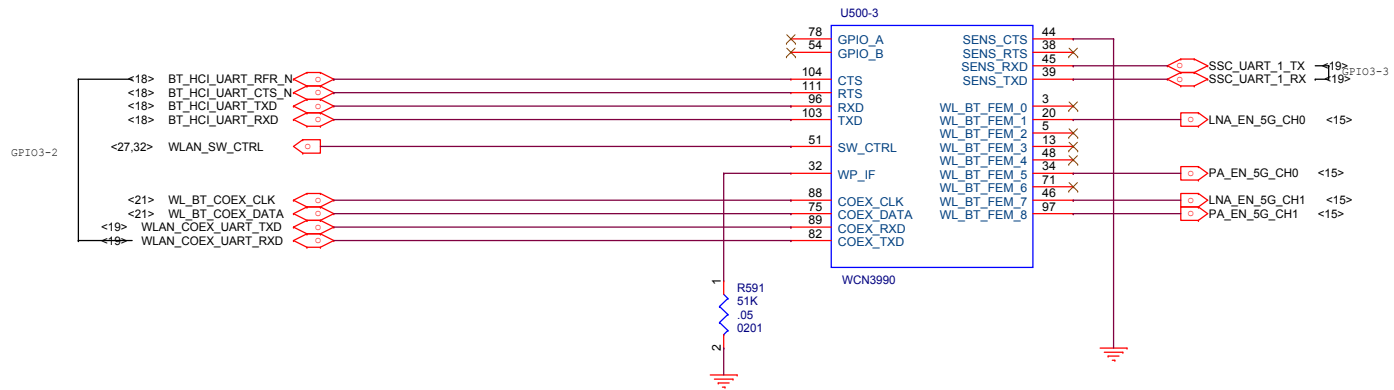
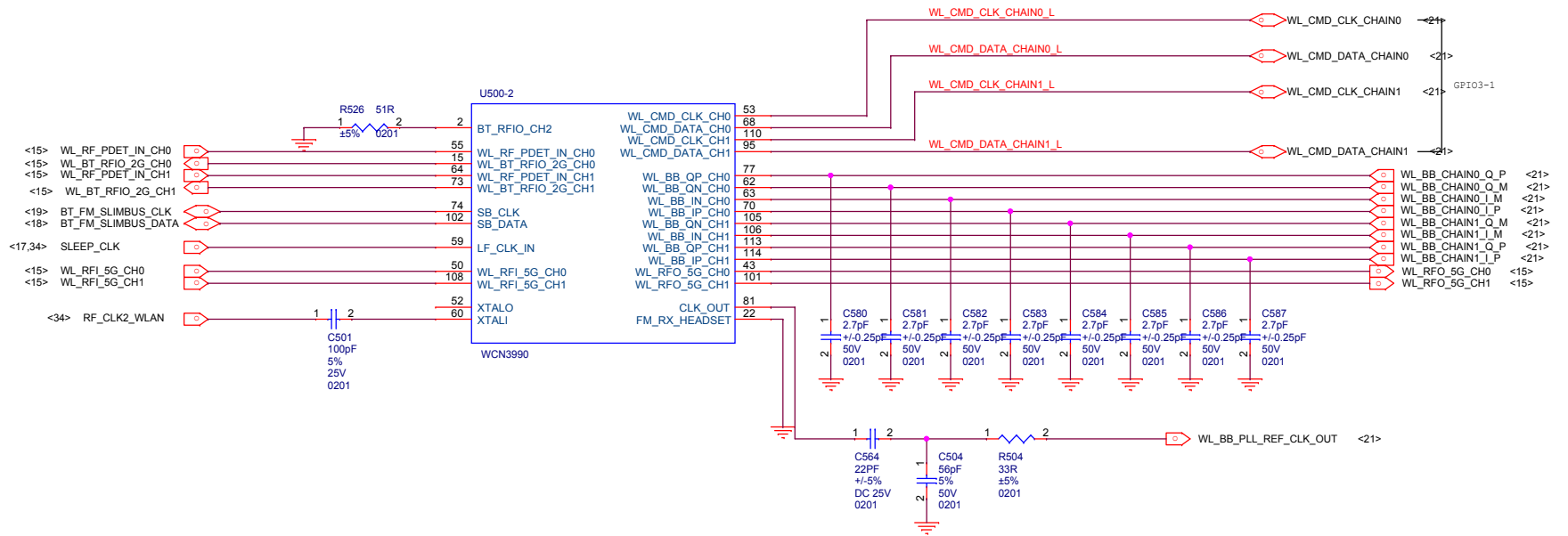



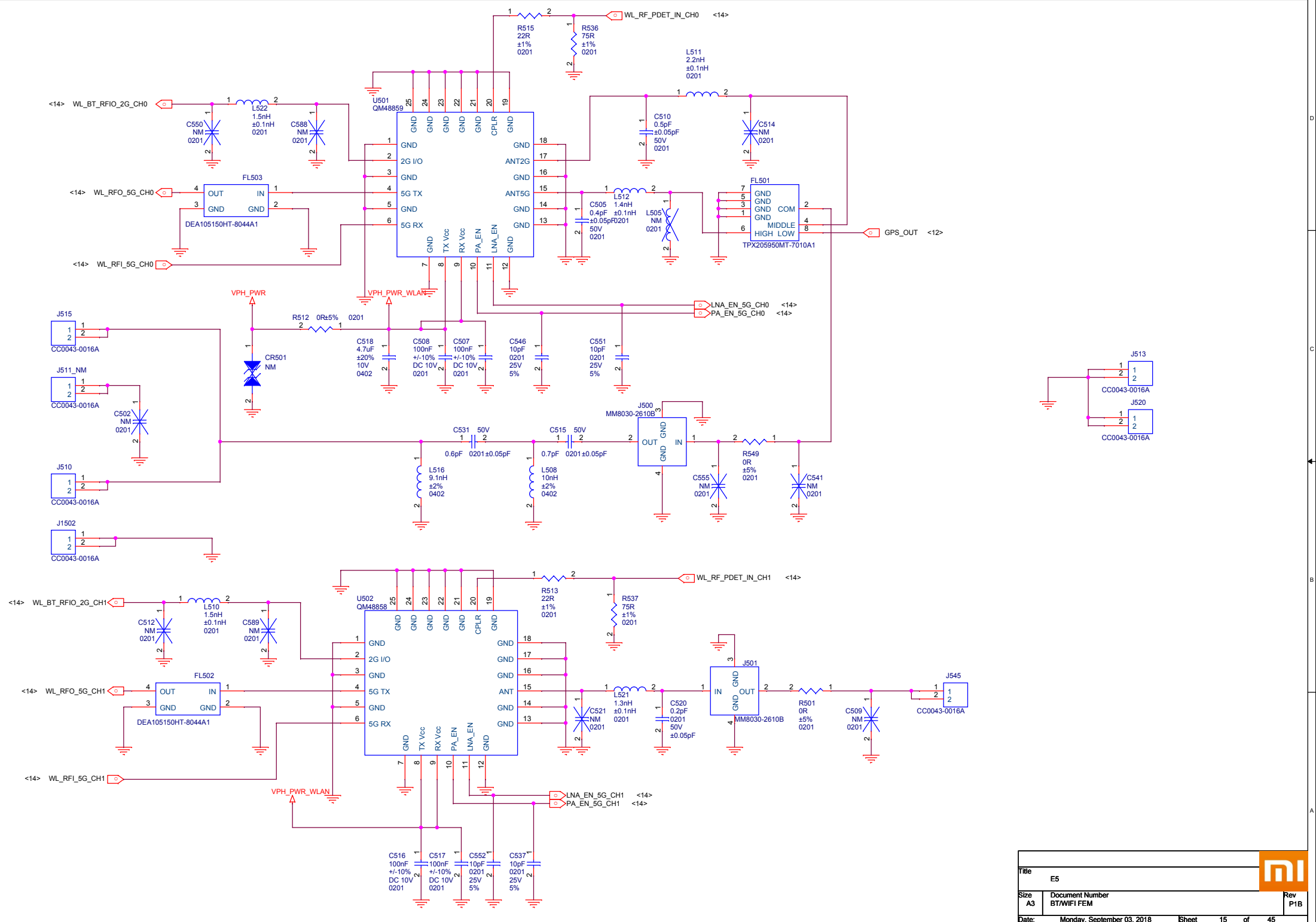

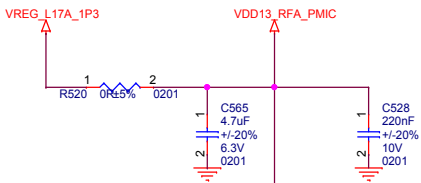

**1.3V\_RFA**

PIN 27

PIN 84

PIN 33

PIN 90

PIN 12

PIN 66

PIN 8

PIN 11,18

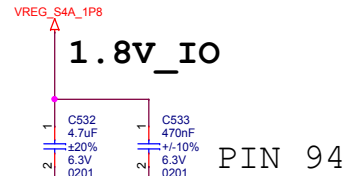

**1.8V\_IO**

PIN 94

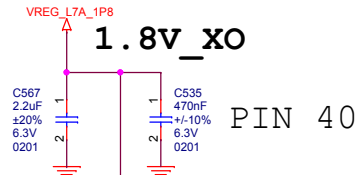

**1.8V\_XO**

PIN 40

PIN 91

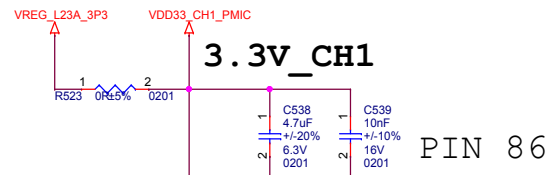

**3.3V\_CH1**

PIN 86

PIN 92

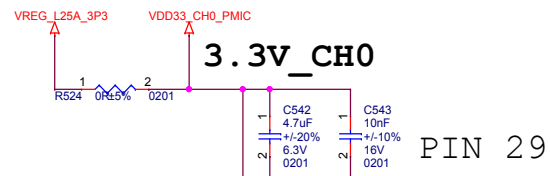

**3.3V\_CHO**

PIN 29

PIN 35

PIN 6

PIN 9

PIN 23,30

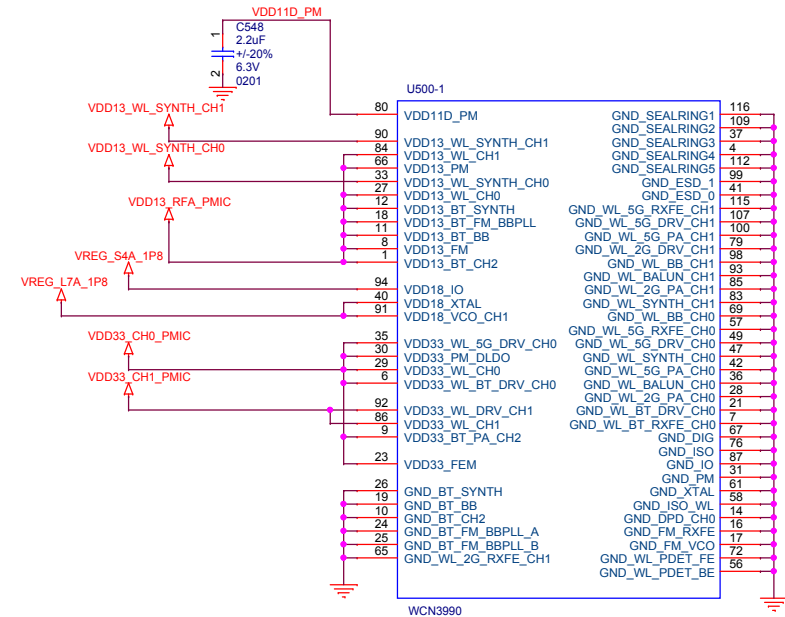

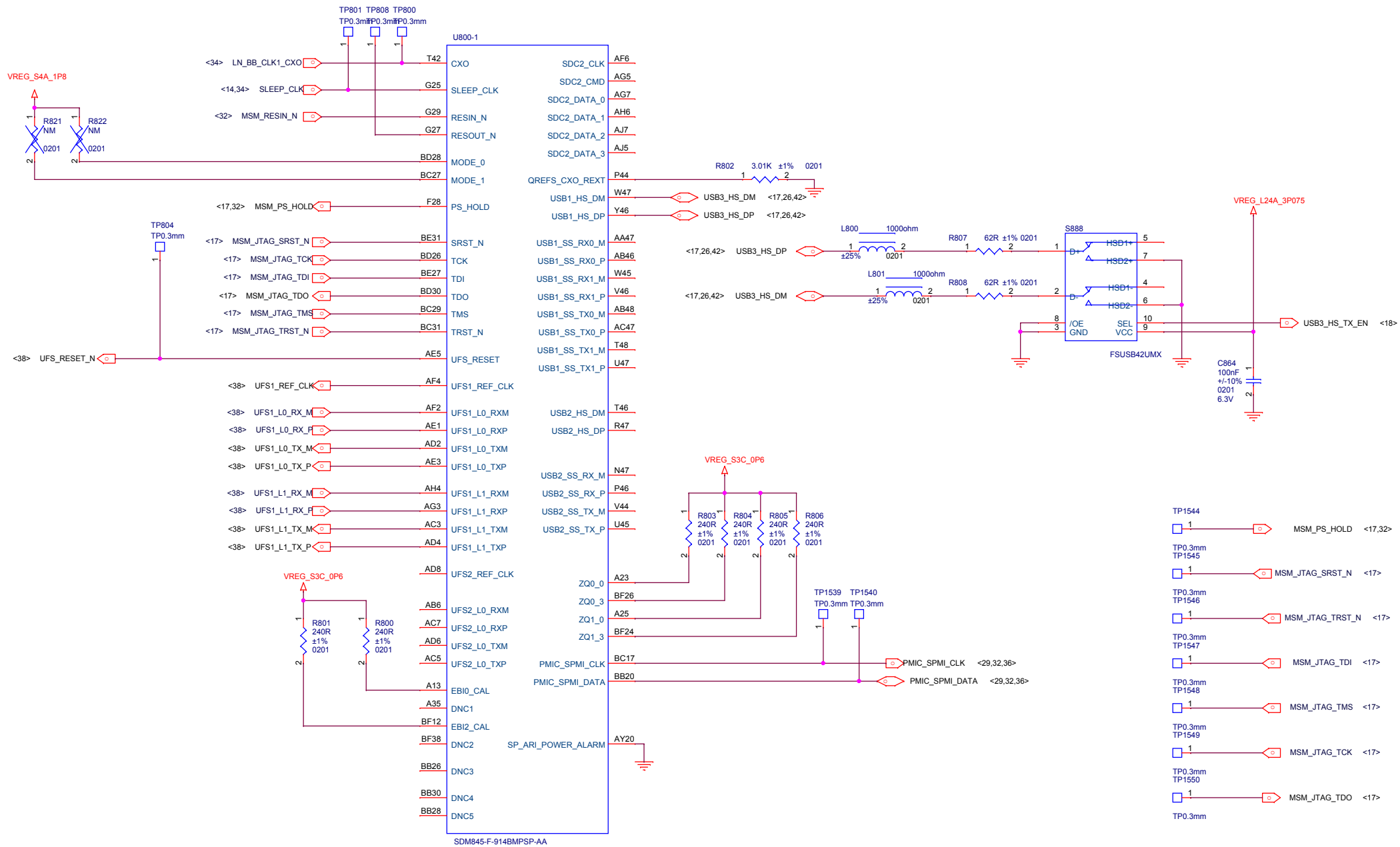

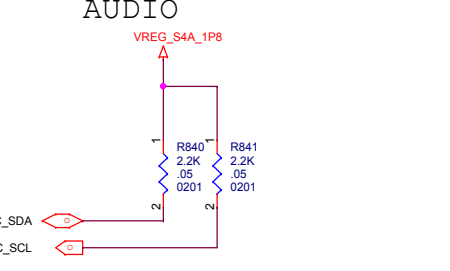
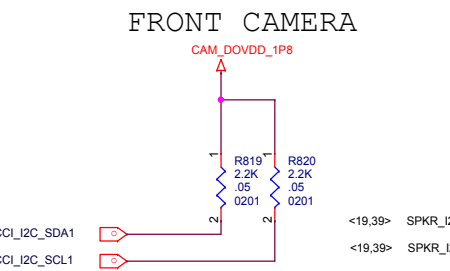
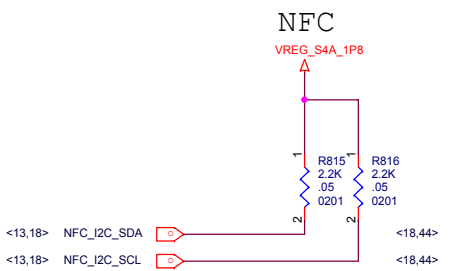
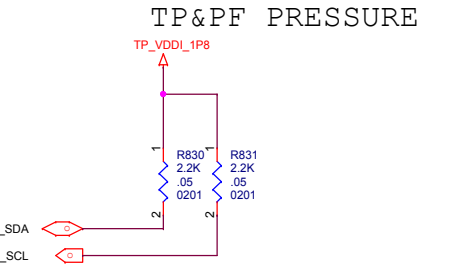
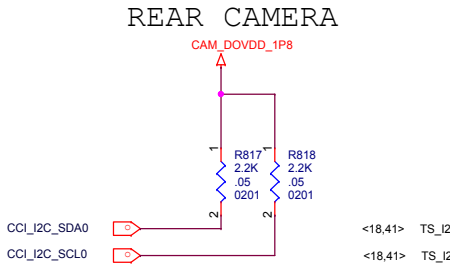
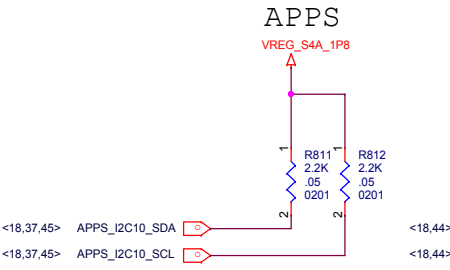
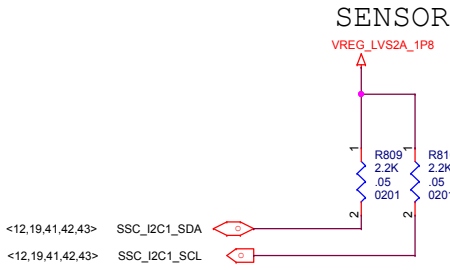
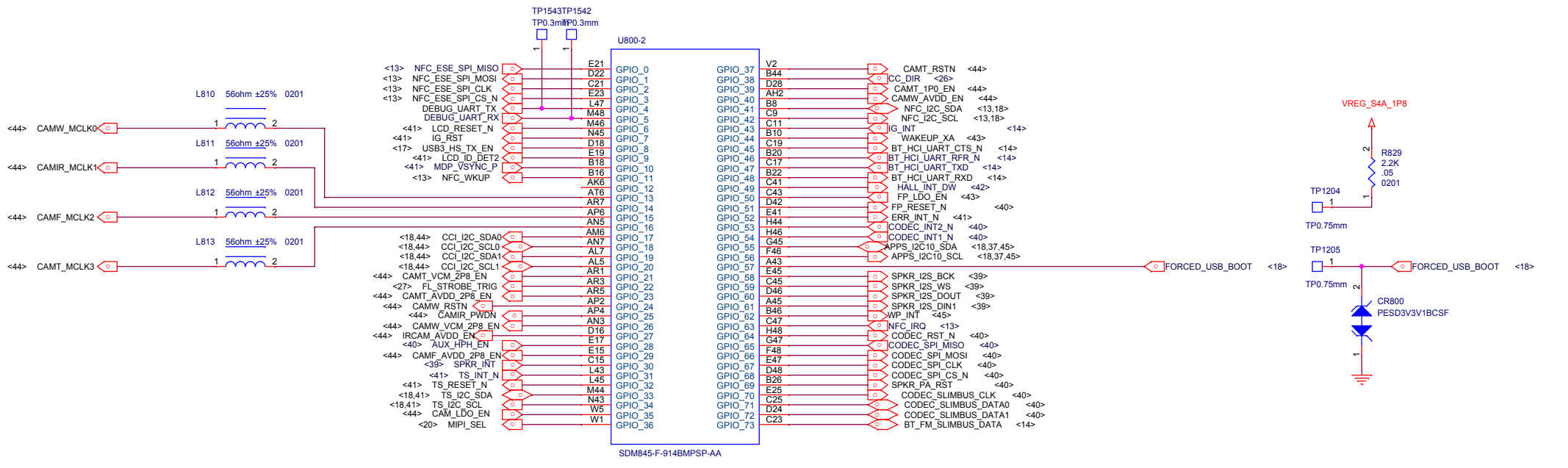

Title		E5	
Size	Document Number	SDM845 GPIO1	
Date:	Monday, September 03, 2018	Sheet	18 of 45

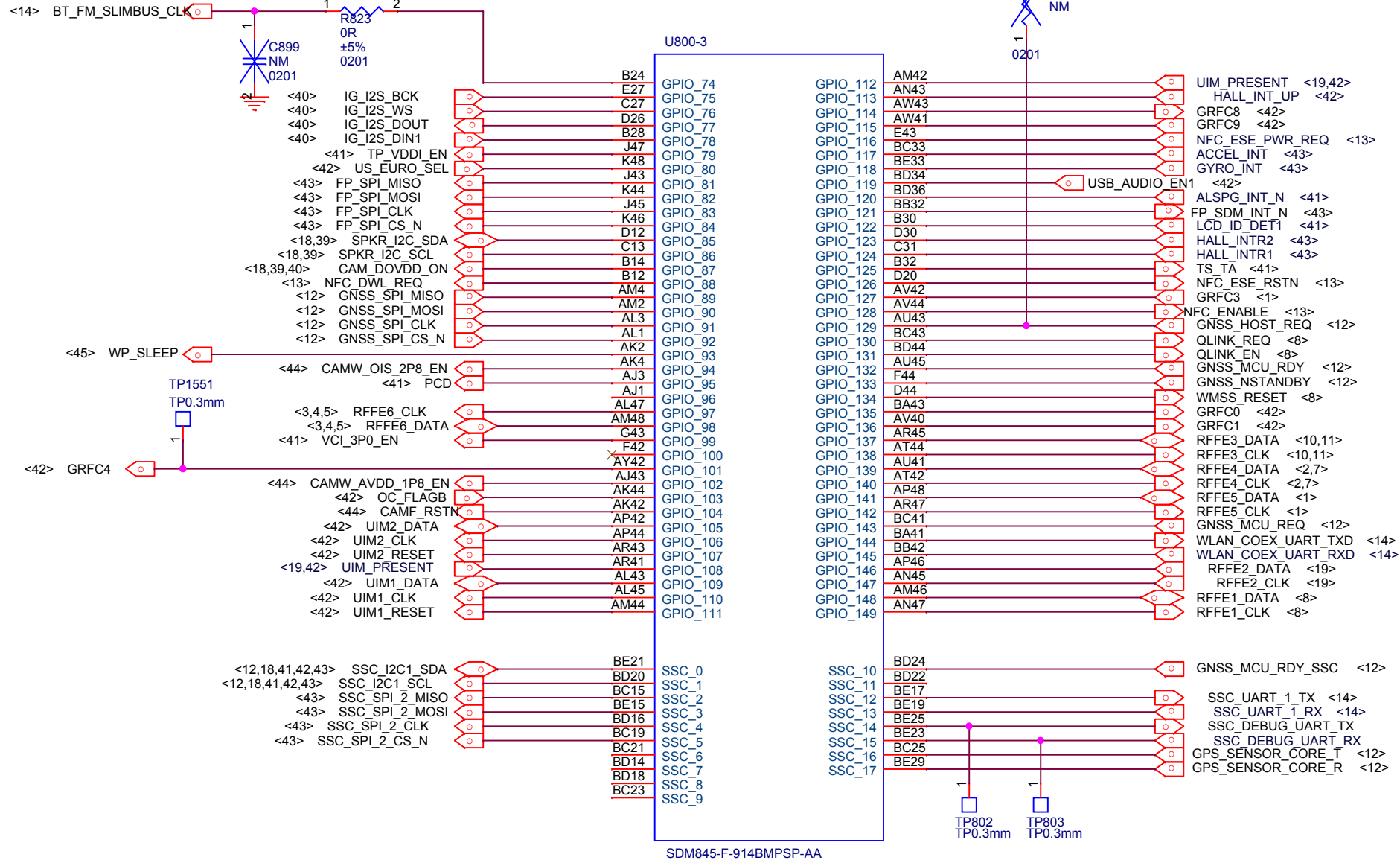

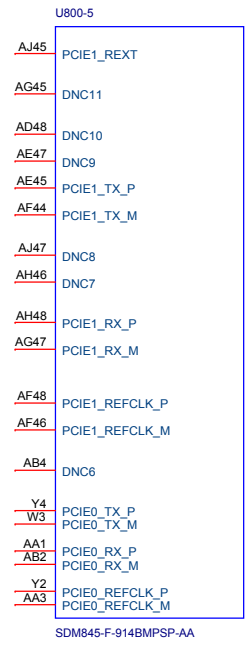
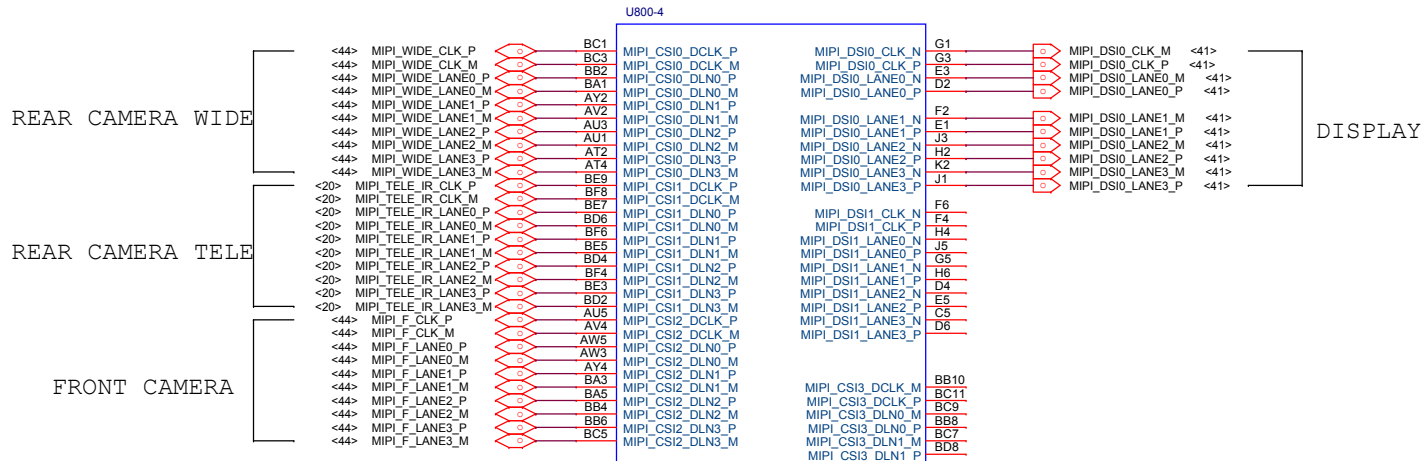

TELE-IR SWITCH

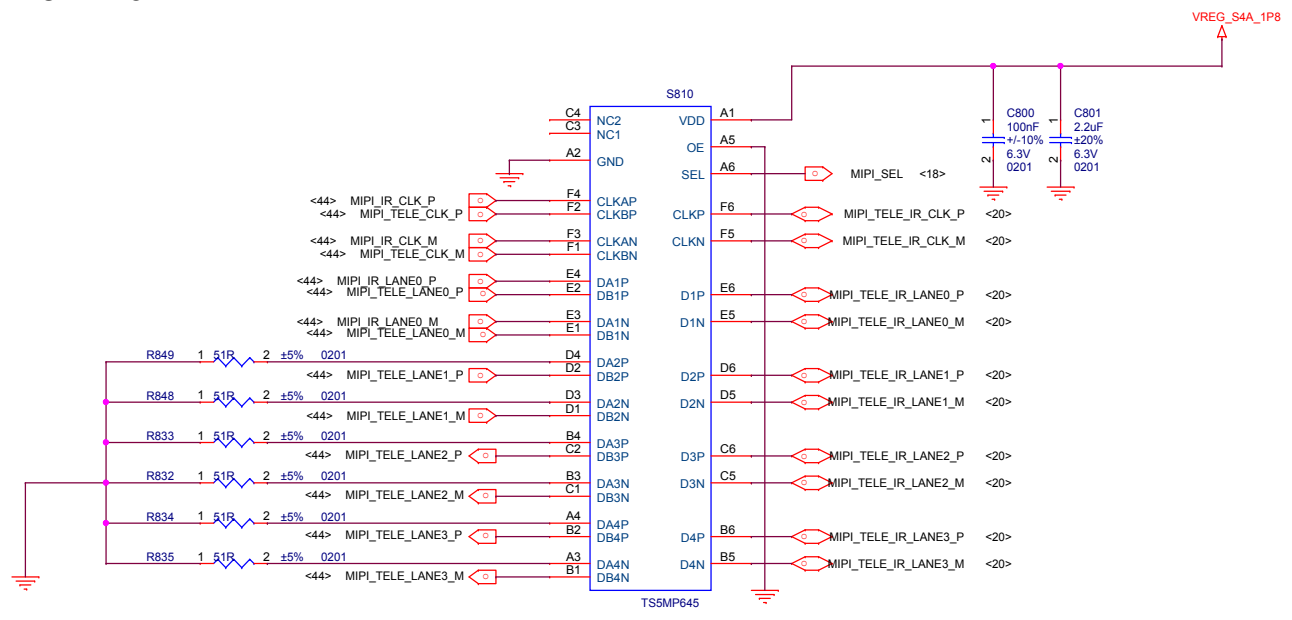

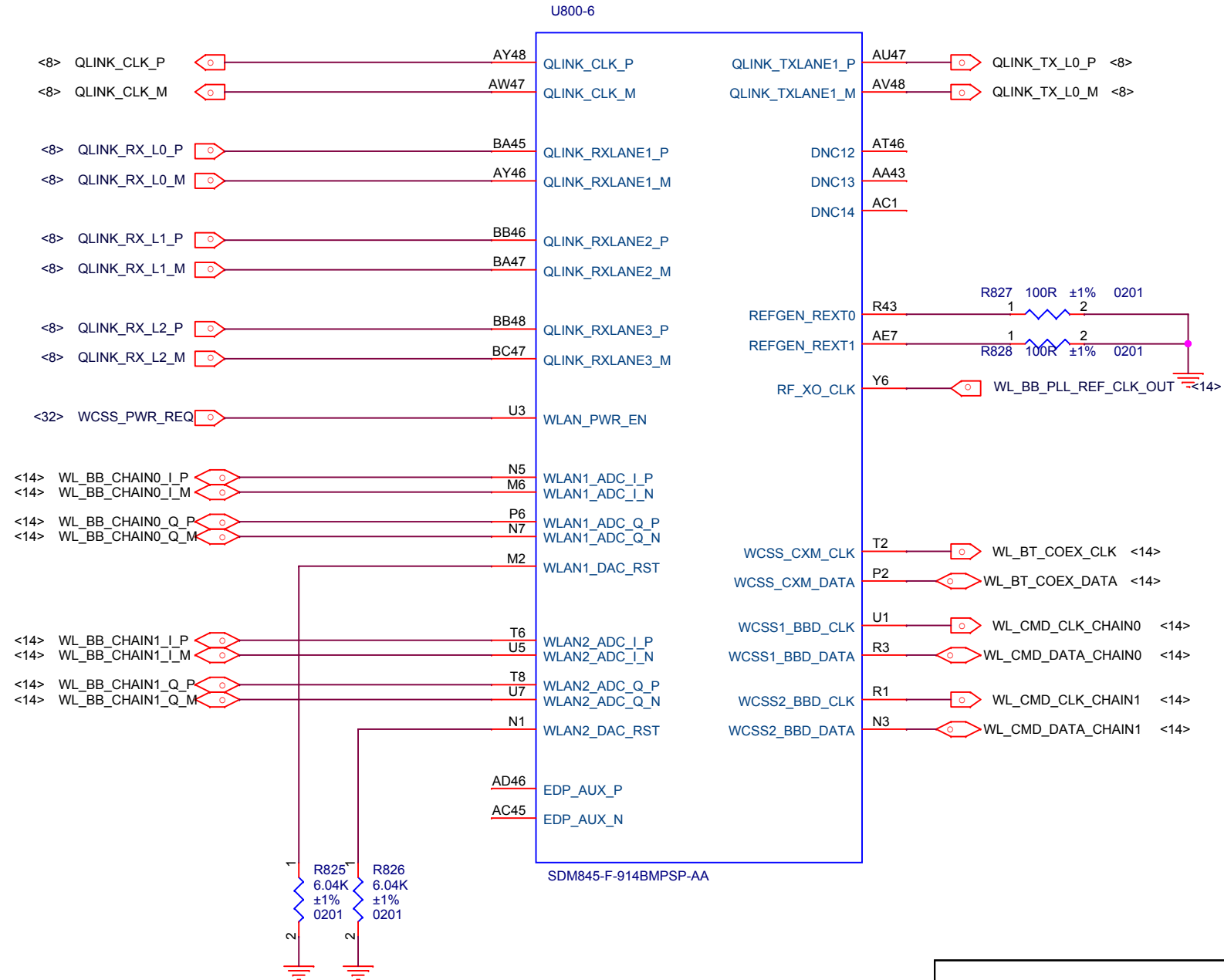

Title			
E5			
Size	Document Number	Rev	
A4	SDM845 RF INTF	P1B	
Date:	Monday, September 03, 2018	Sheet	21 of 45

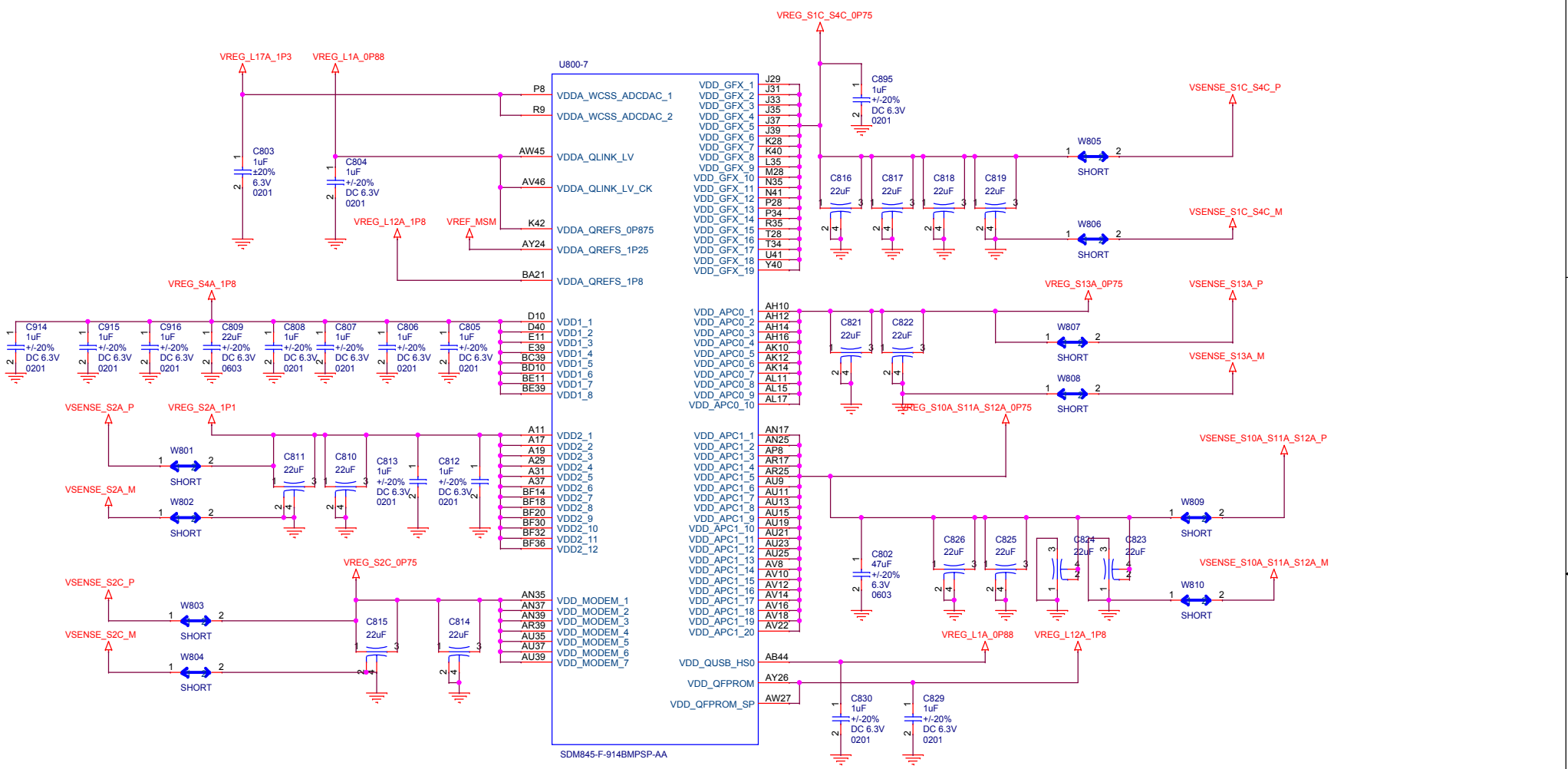



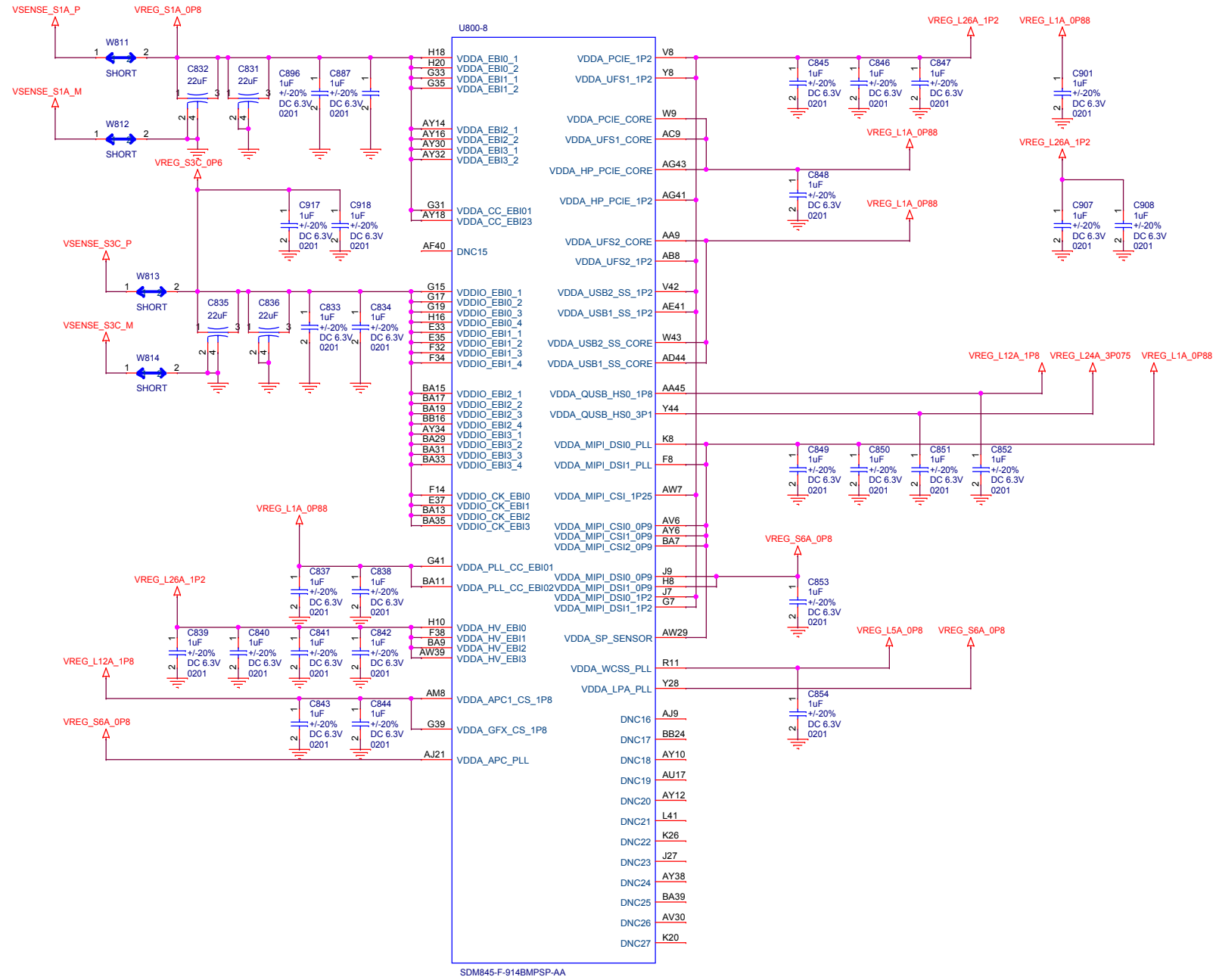

SDM845-F-914BMPSP-AA

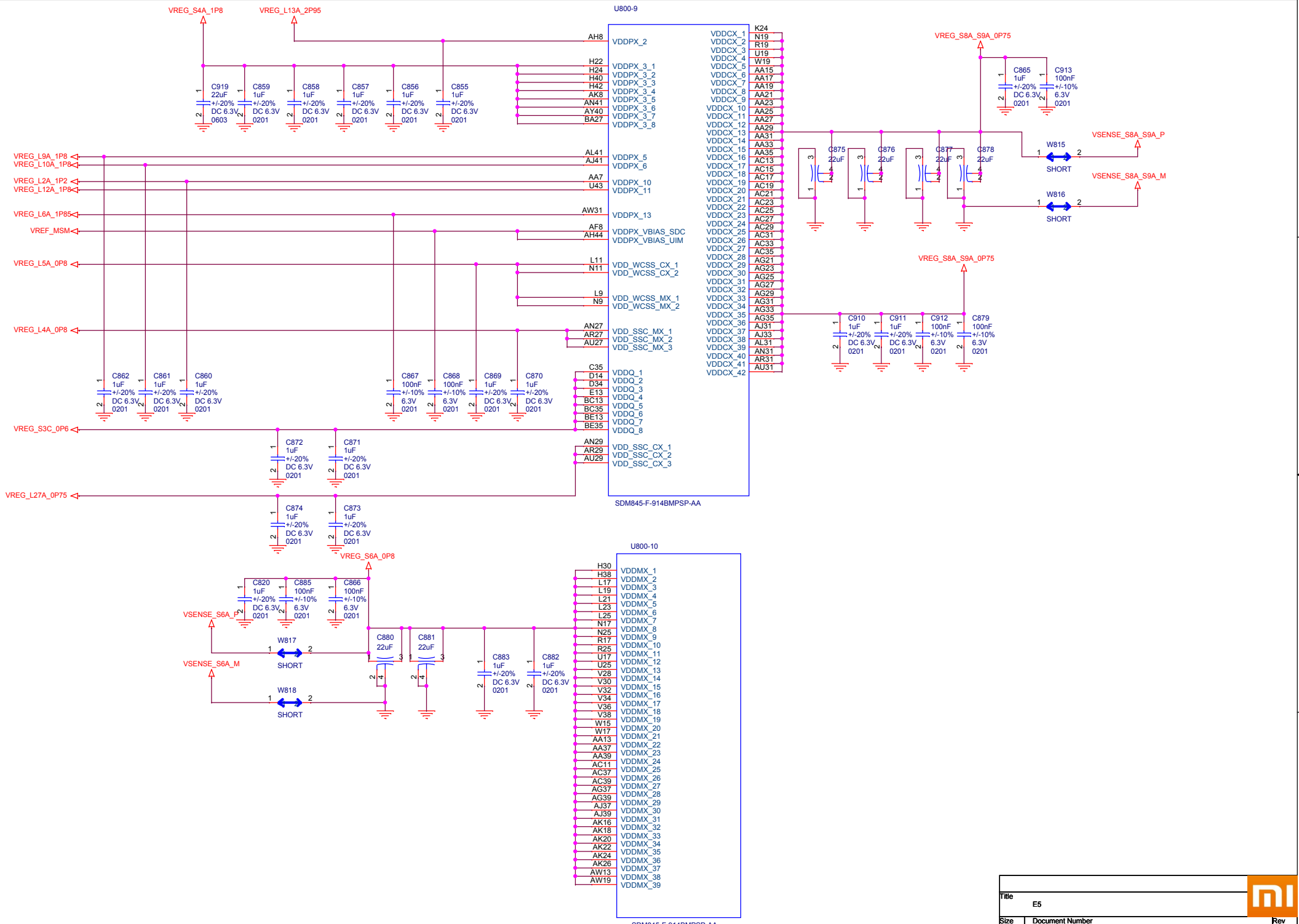

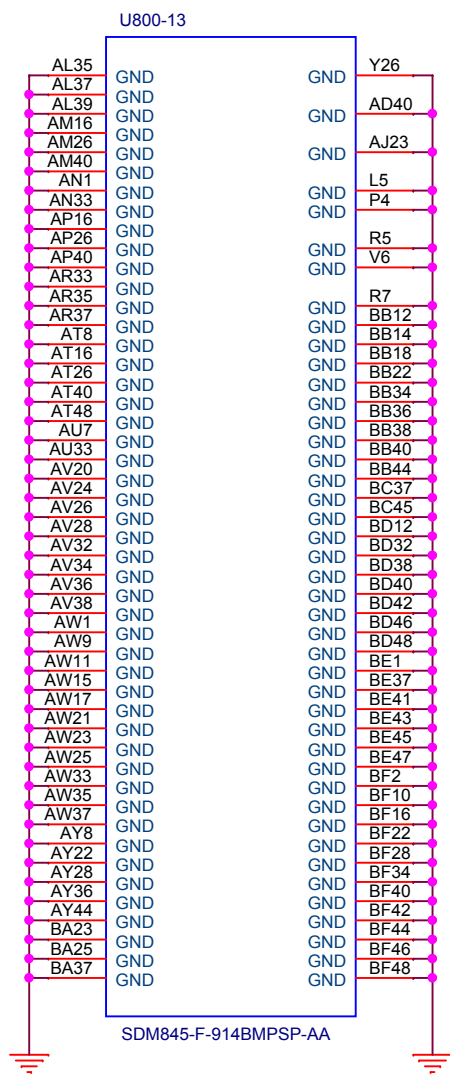
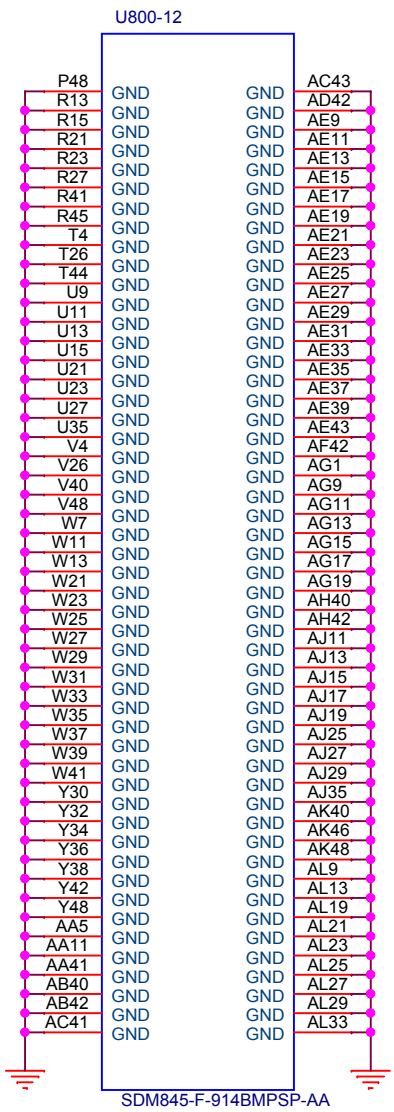
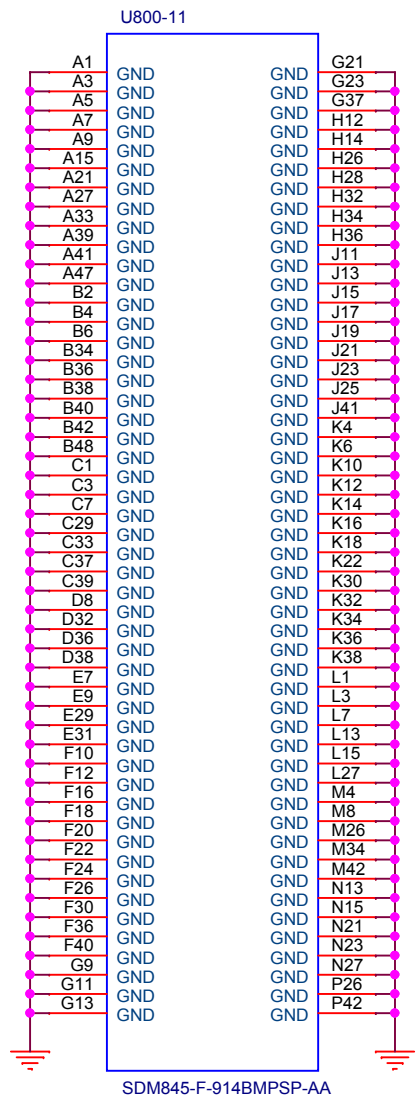

# PMI8998

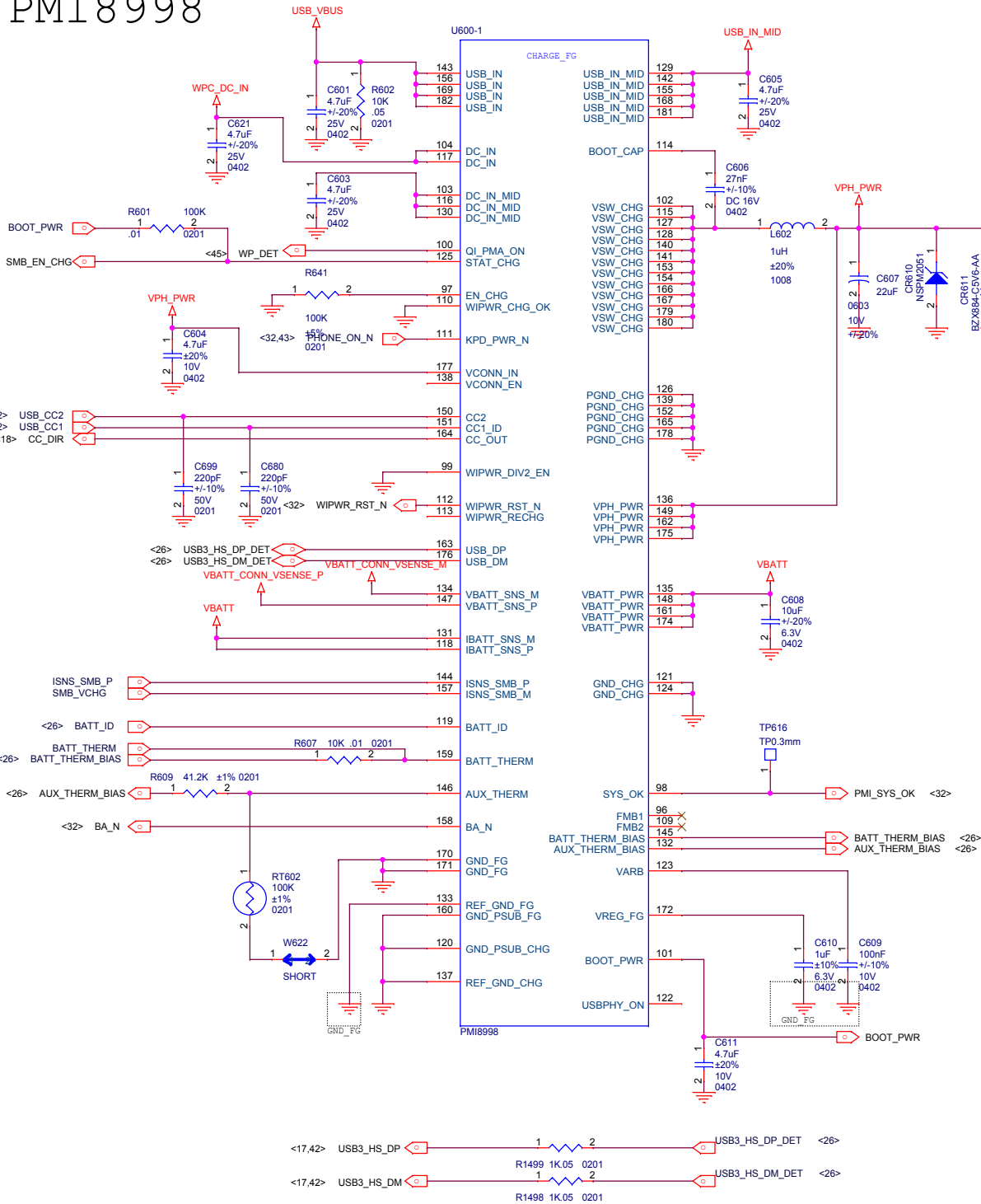

## BATTERY

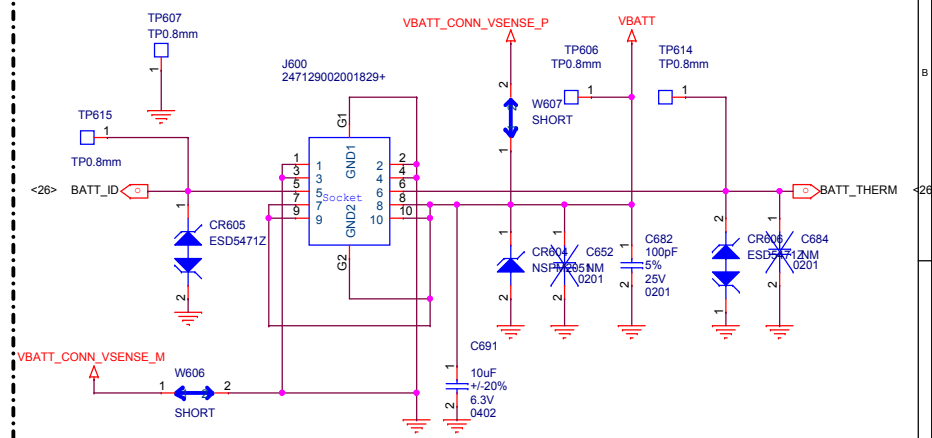

Title		E5	
Size	Document Number	PMI8998 CHARGE	
Date:	Monday, September 03, 2018	Sheet	26 of 45

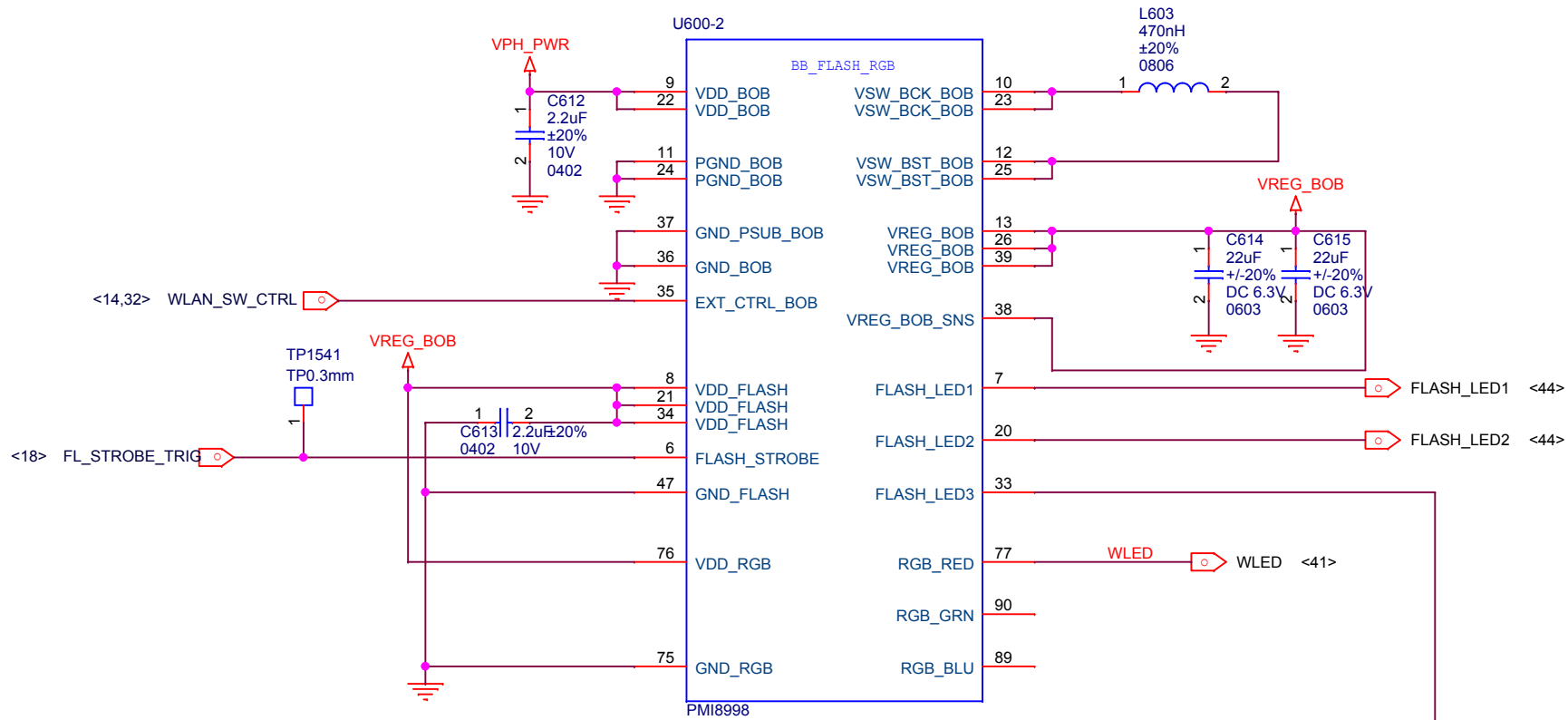

Title			mi
E5			
Size	Document Number	Rev	P1B
A4	PMI8998 FLASH RGB		
Date:	Monday, September 03, 2018	Sheet	27 of 45

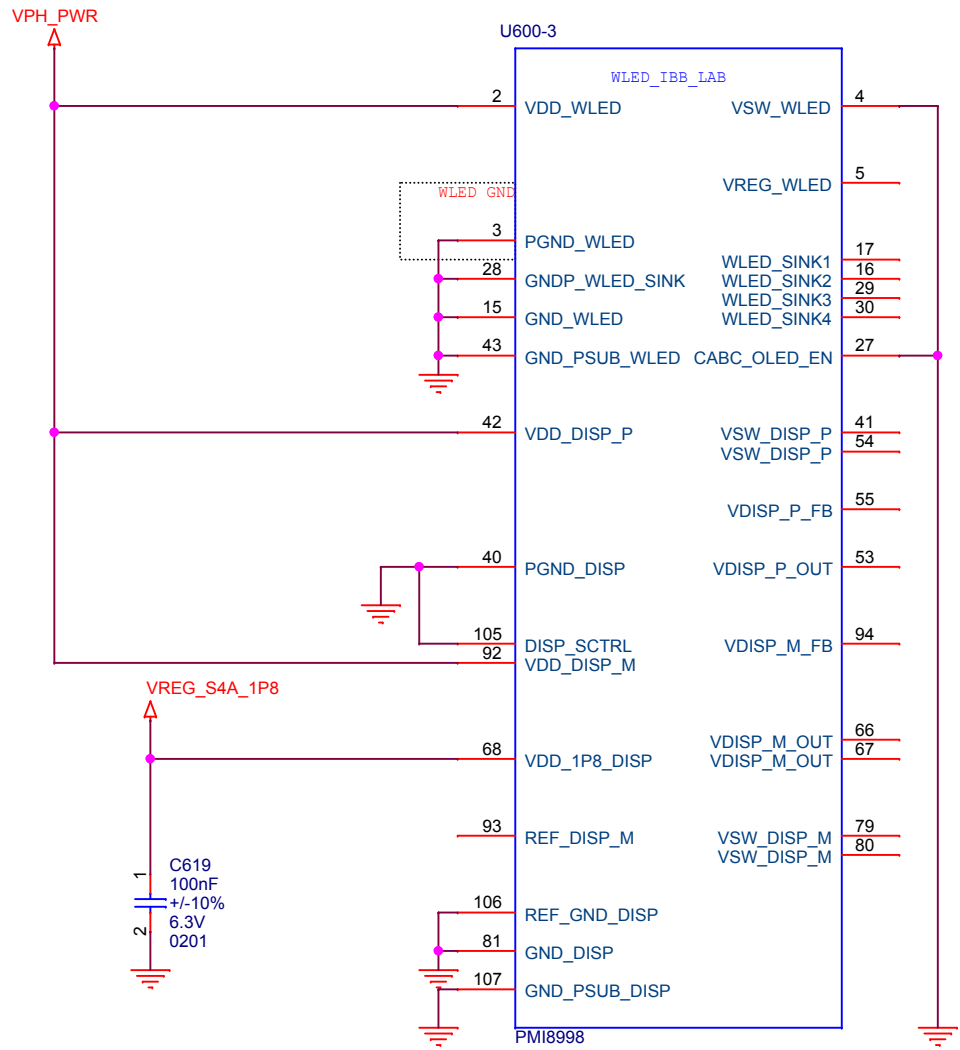

Title		E5		
Size	Document Number		Rev	
A4	PMI8998 WLED IBB LAB		P1B	
Date:	Monday, September 03, 2018	Sheet	28 of 45	

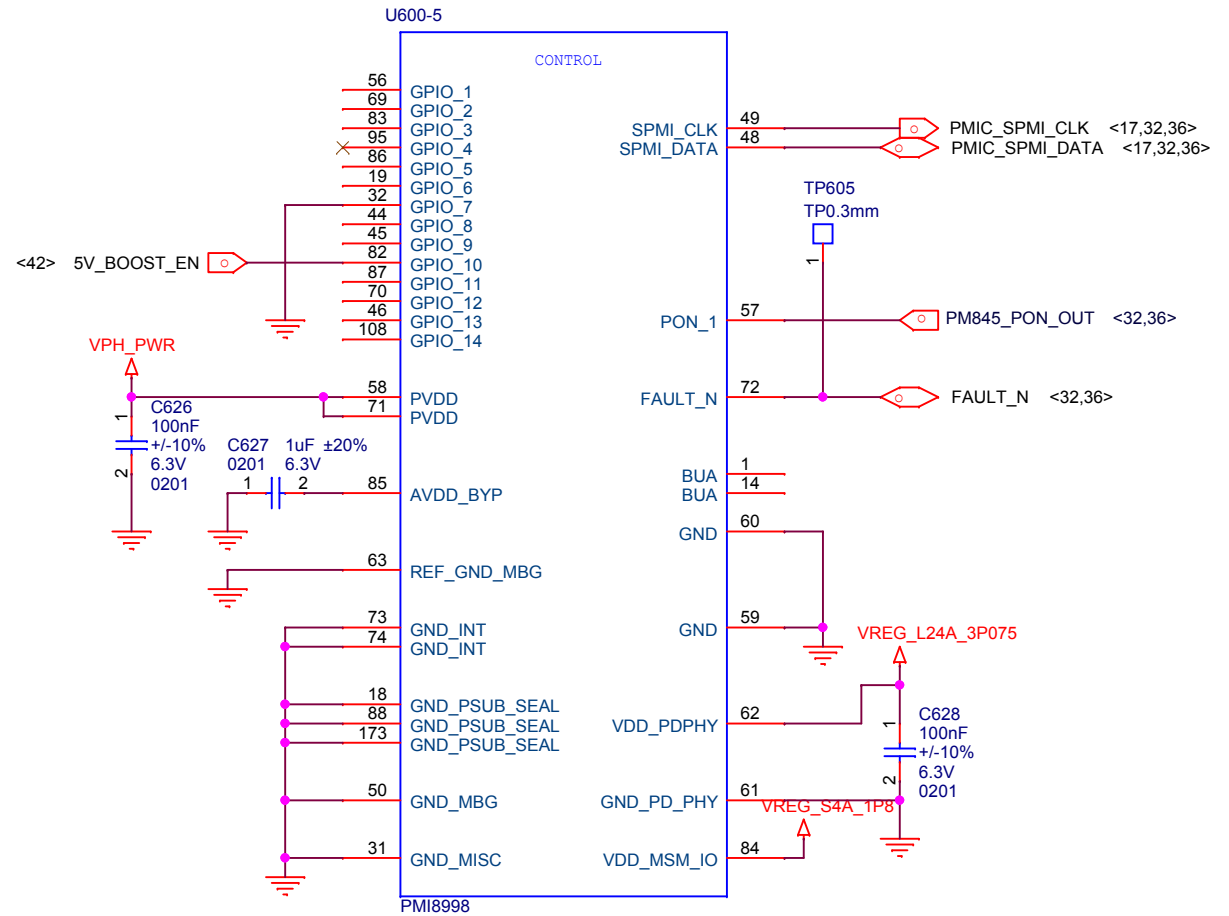
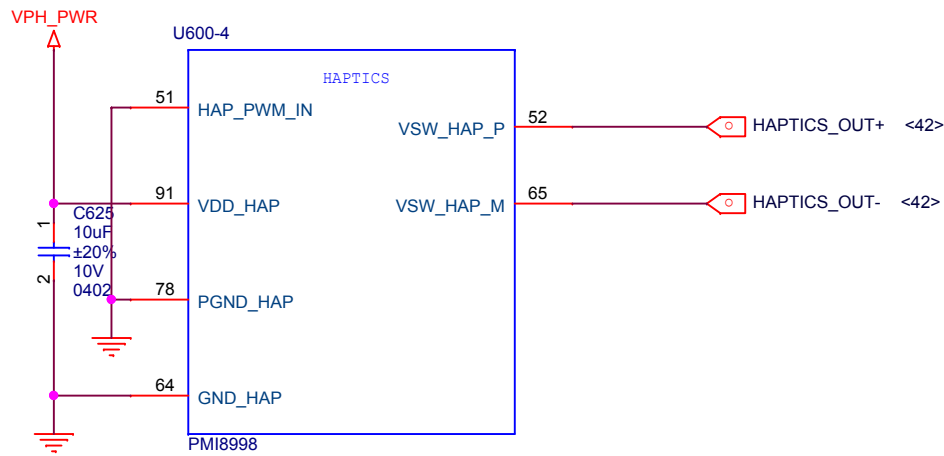

Title		E5				
Size	A4	Document Number	PMI8998 HAPTICS&SIDEKEY		Rev	P1B
Date:	Monday, September 03, 2018		Sheet	29	of	45

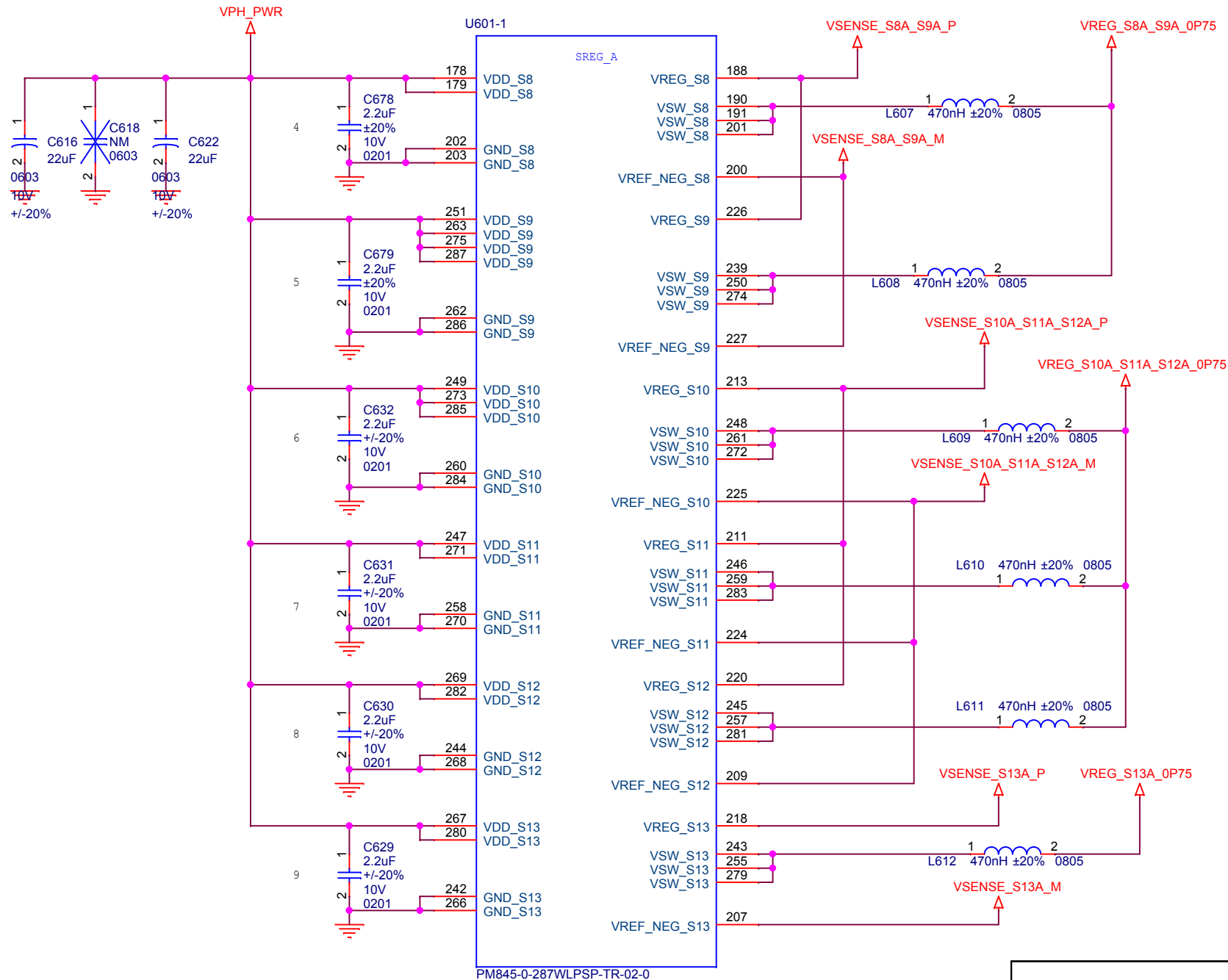

PM845-0-287WLPSP-TR-02-0

Title		E5				
Size	A4	Document Number	PM845 SREG A		Rev	P1B
Date:	Monday, September 03, 2018		Sheet	30	of	45



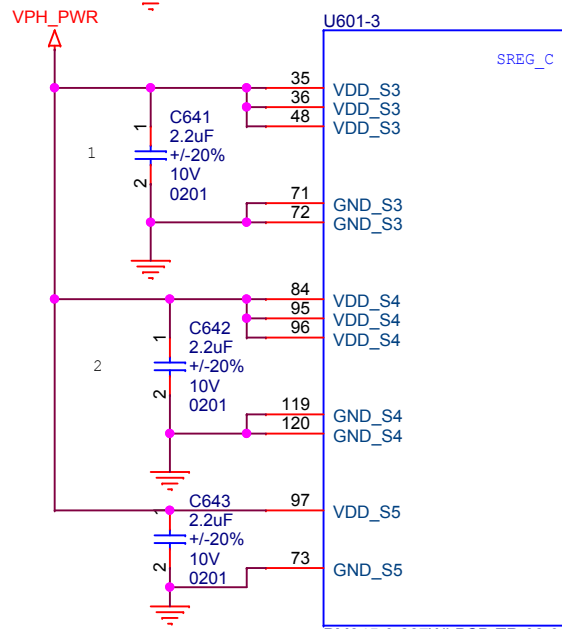
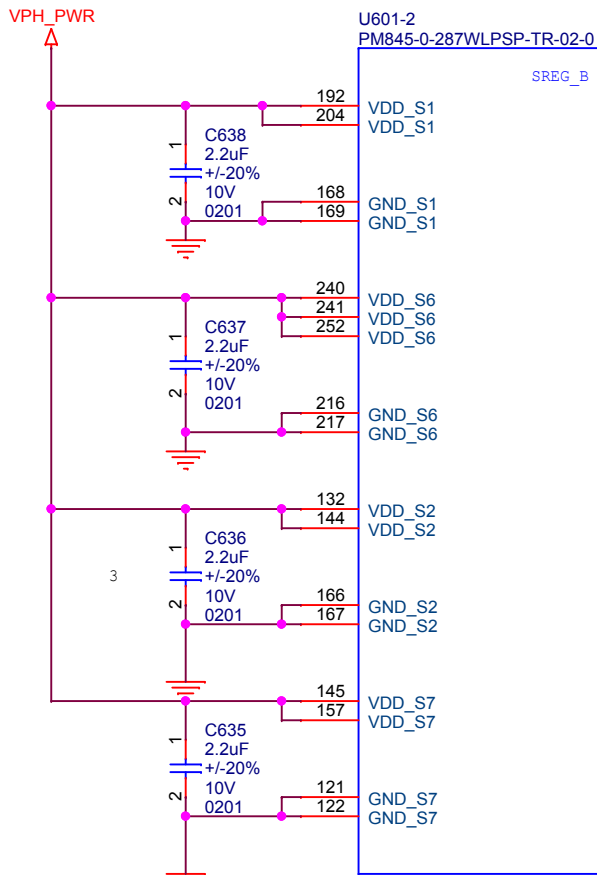

Title		E5				
Size	A4	Document Number	PM845 SREG B&C		Rev	P1B
Date:	Monday, September 03, 2018		Sheet	31	of	45

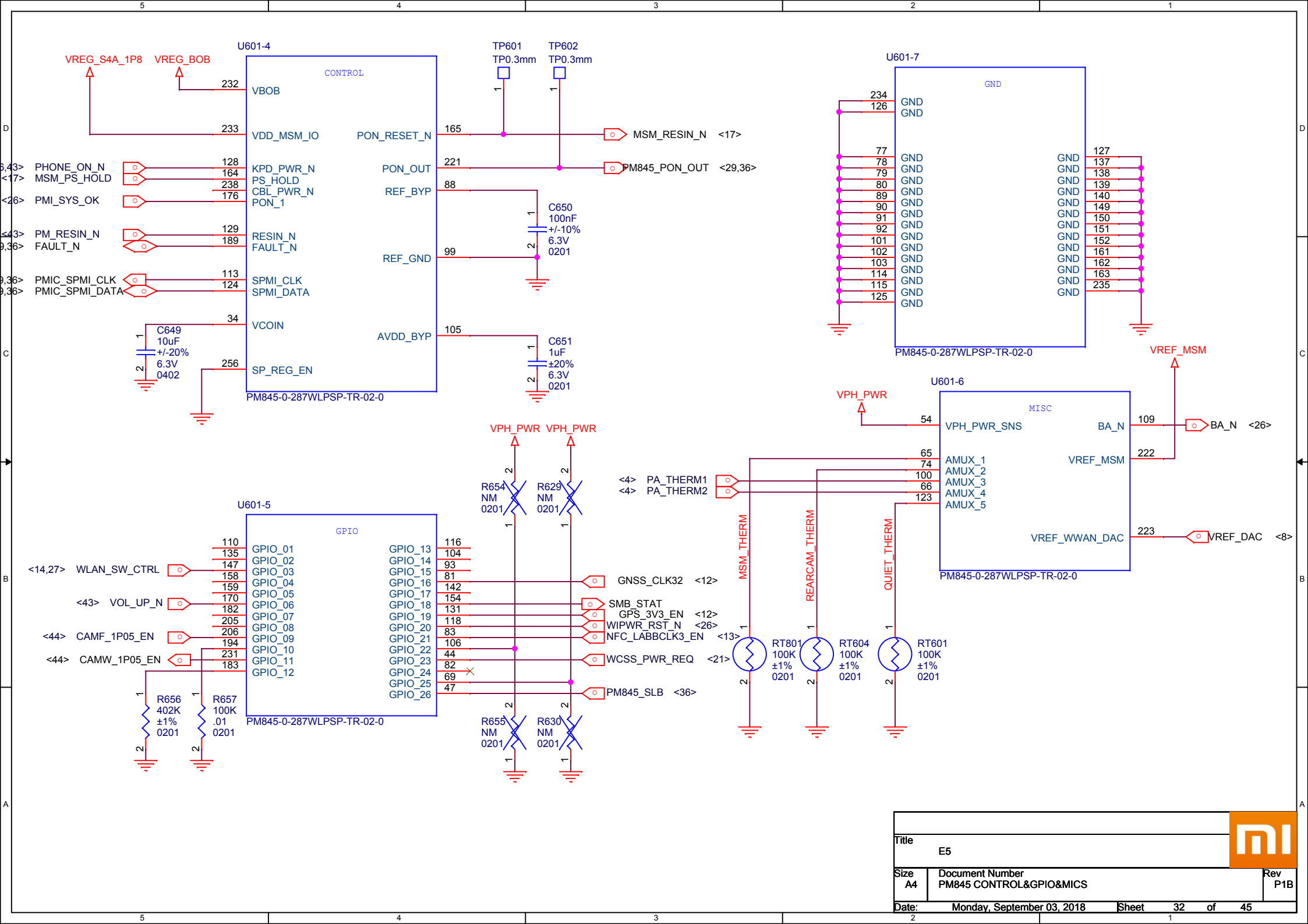

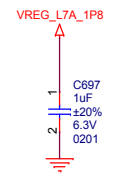
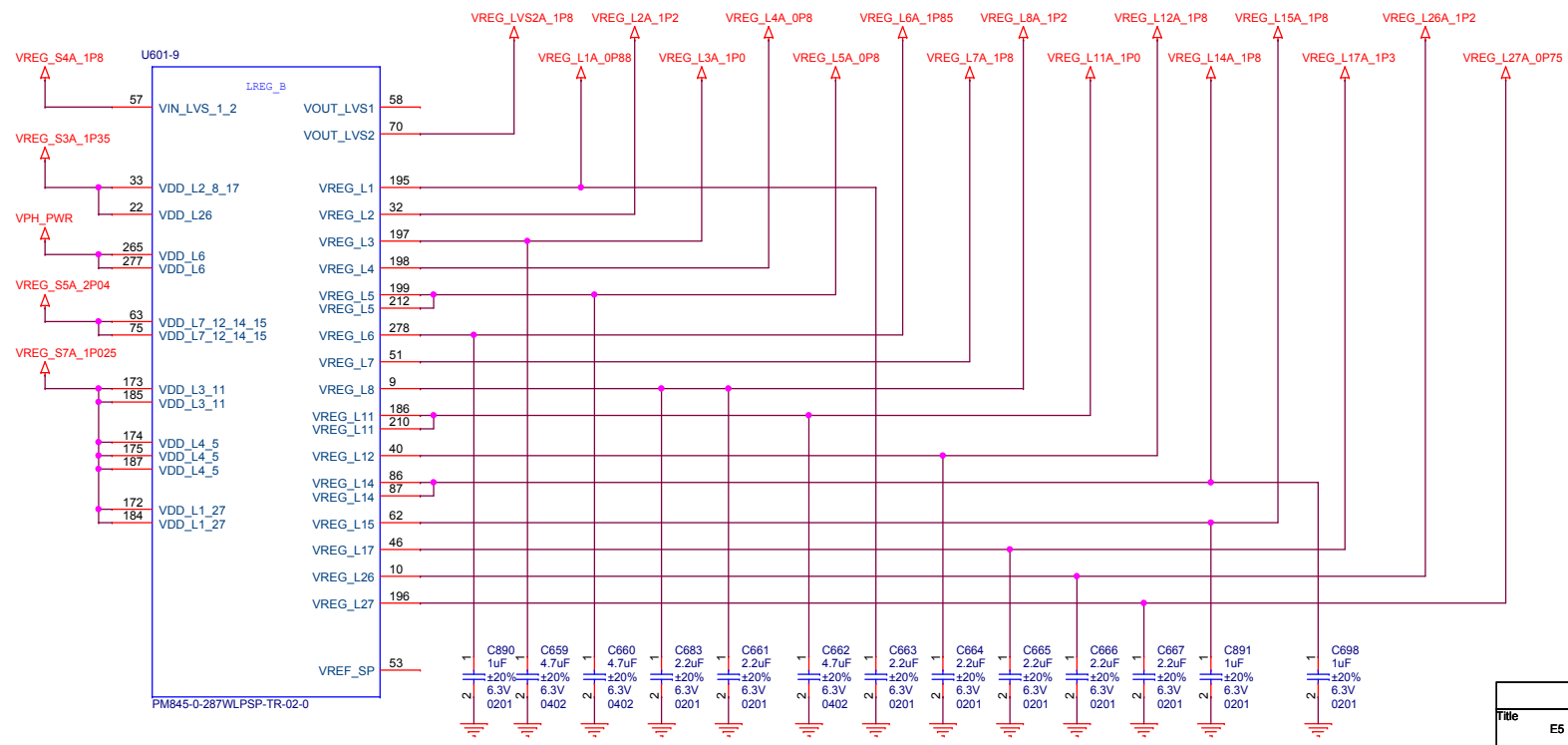
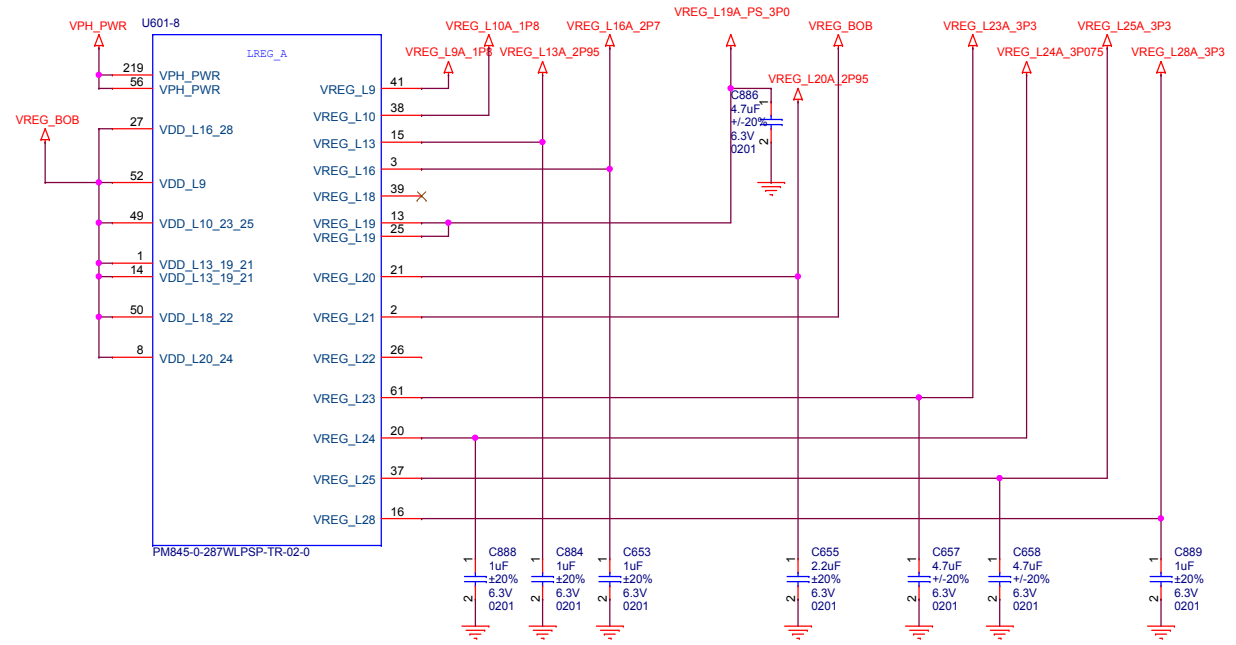

Title		E5				
Size	A4	Document Number	PM845 CONTROL&GPIO&MICS		Rev	P1B
Date:	Monday, September 03, 2018		Sheet	32	of	45

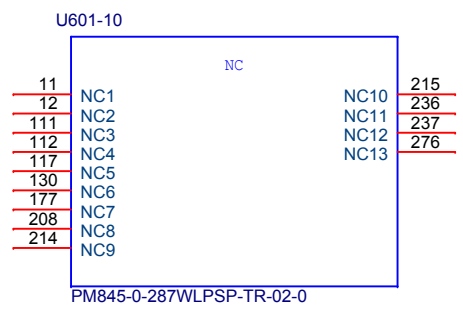
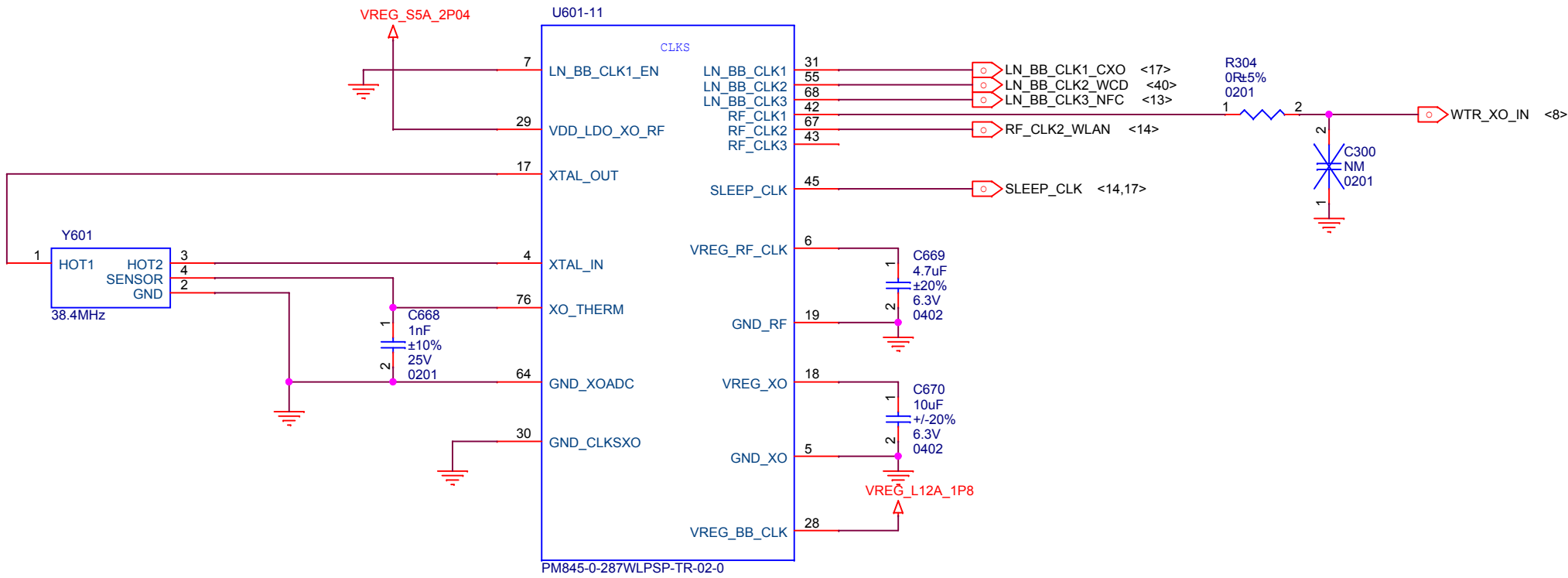

Title		E5	
Size	Document Number	PM845 LREG A&B	
A3	Date:	Monday, September 03, 2018	Rev P1B
Sheet		33	of 45

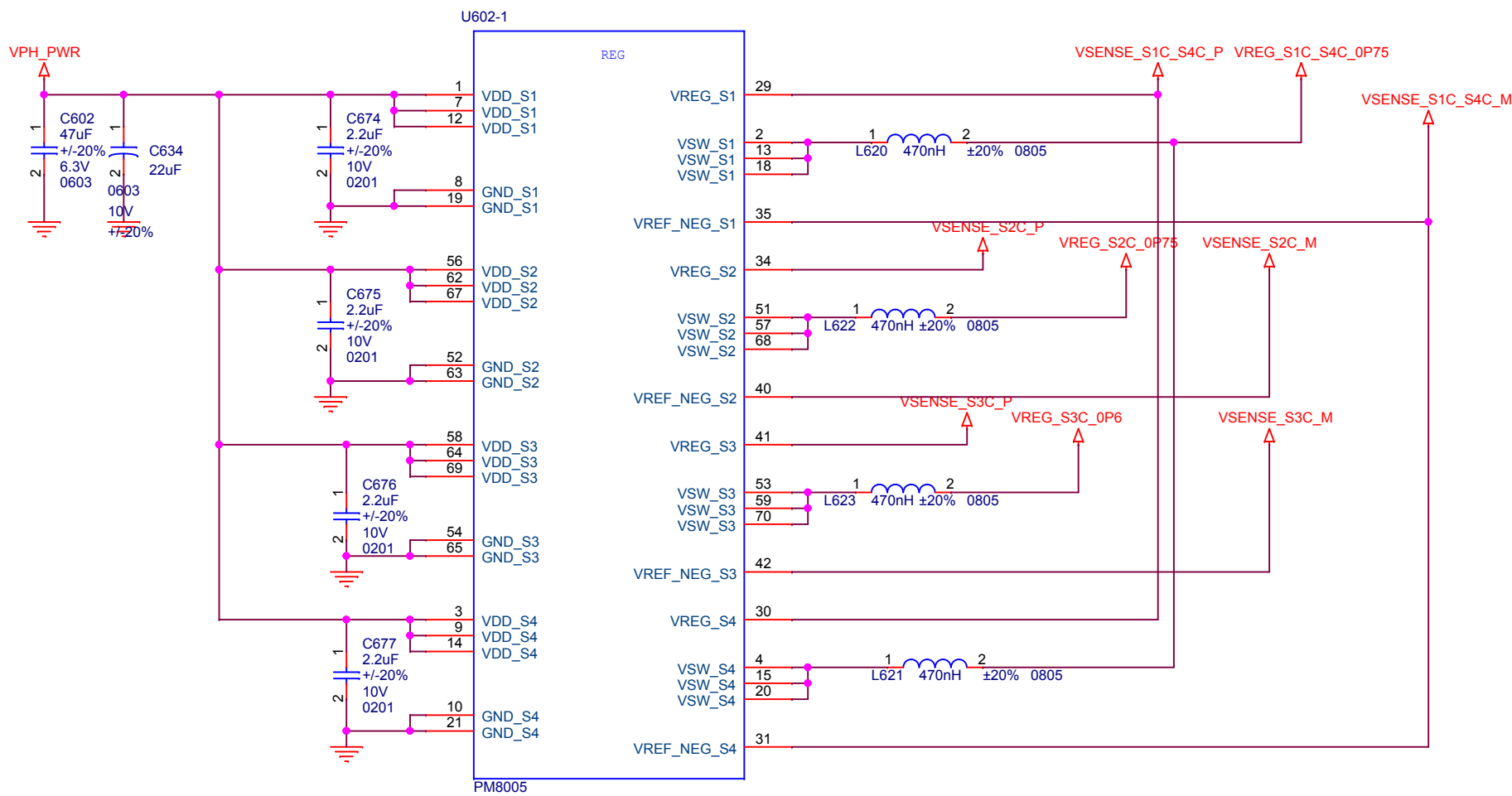



Title		E5	
Size	Document Number	PM8005 REG	
A4			P1B
Date:	Monday, September 03, 2018	Sheet	35 of 45

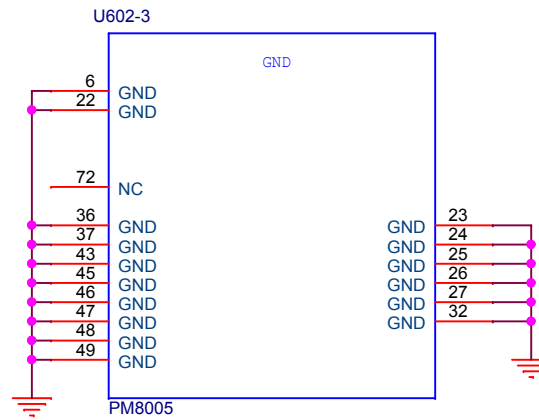
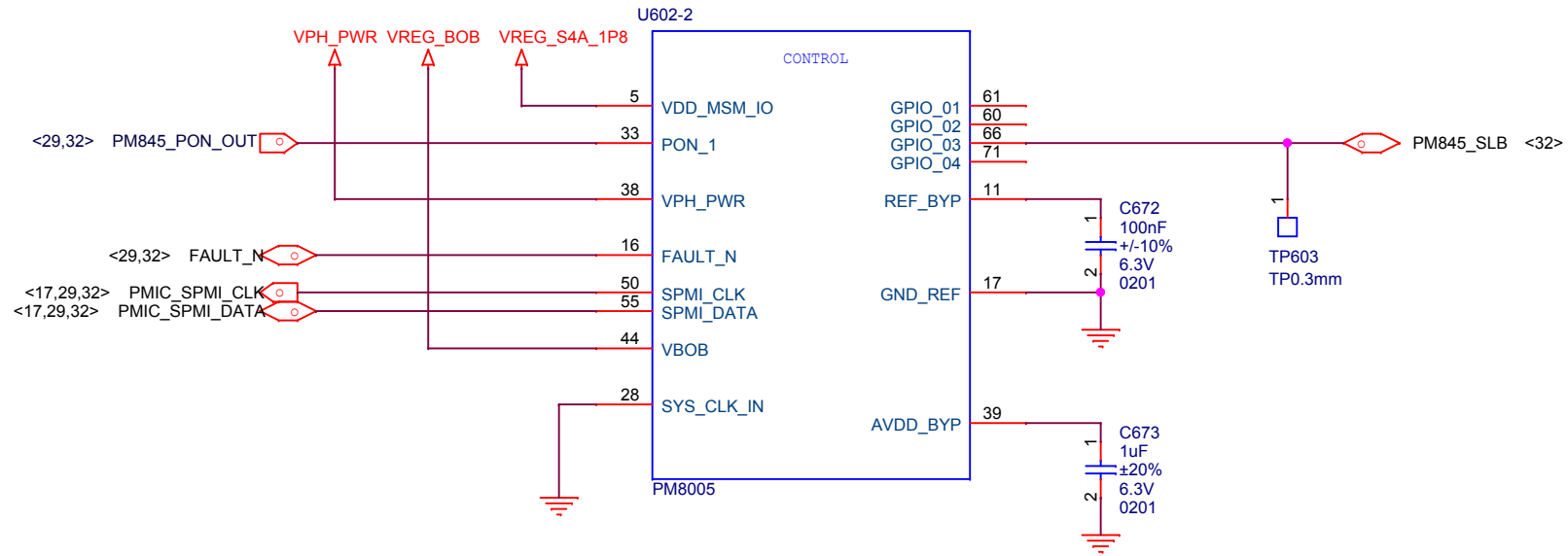

Title		E5	
Size	Document Number	PM8005 CONTROL&GND	
A4			P1B
Date:	Monday, September 03, 2018	Sheet	36 of 45

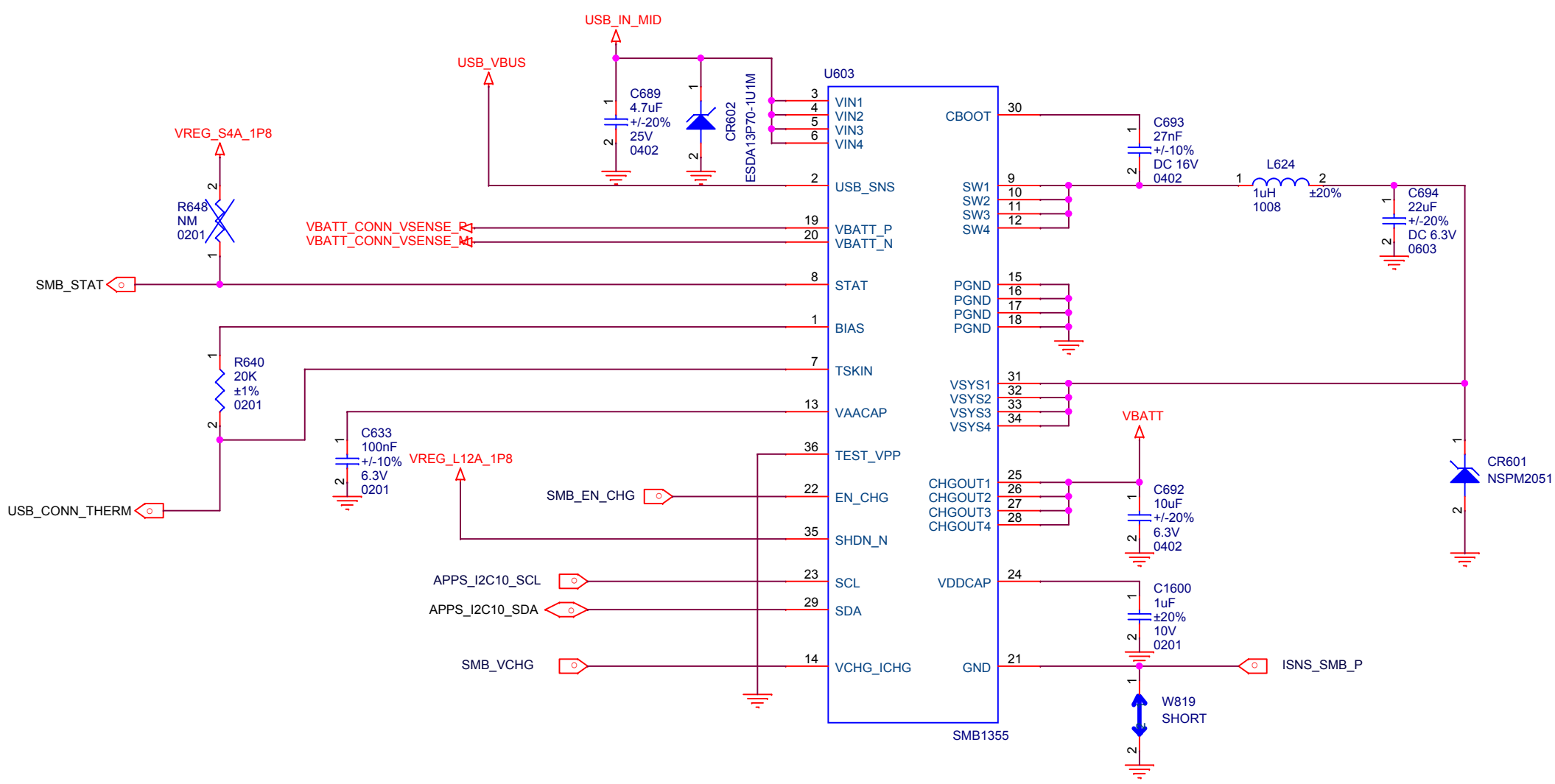

Title		E5			
Size	A4	Document Number	SMB1355		Rev
Date:	Monday, September 03, 2018	Sheet	37	of	45
				Rev	P1B

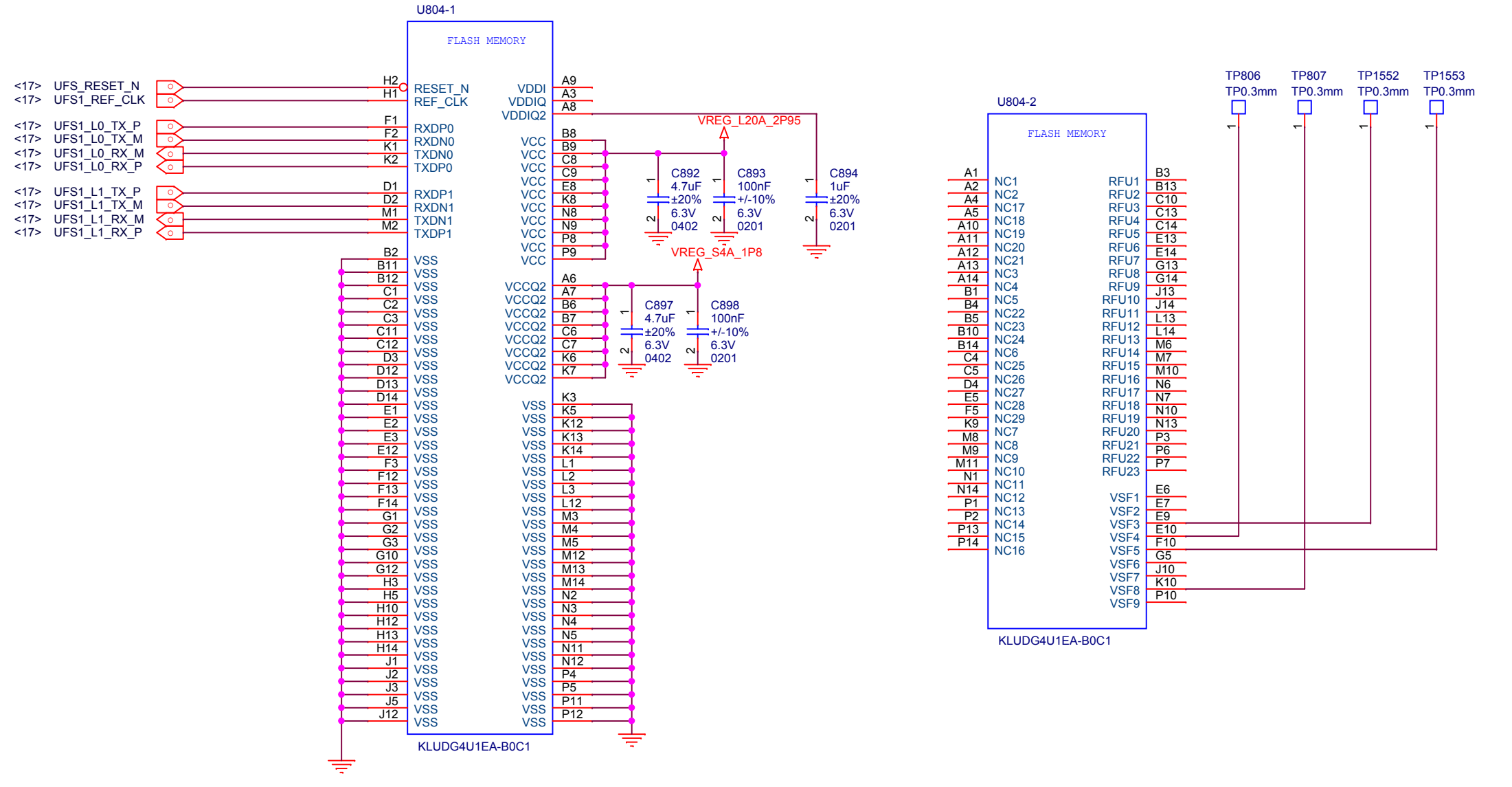

D  
C  
B  
A



# Speaker PA

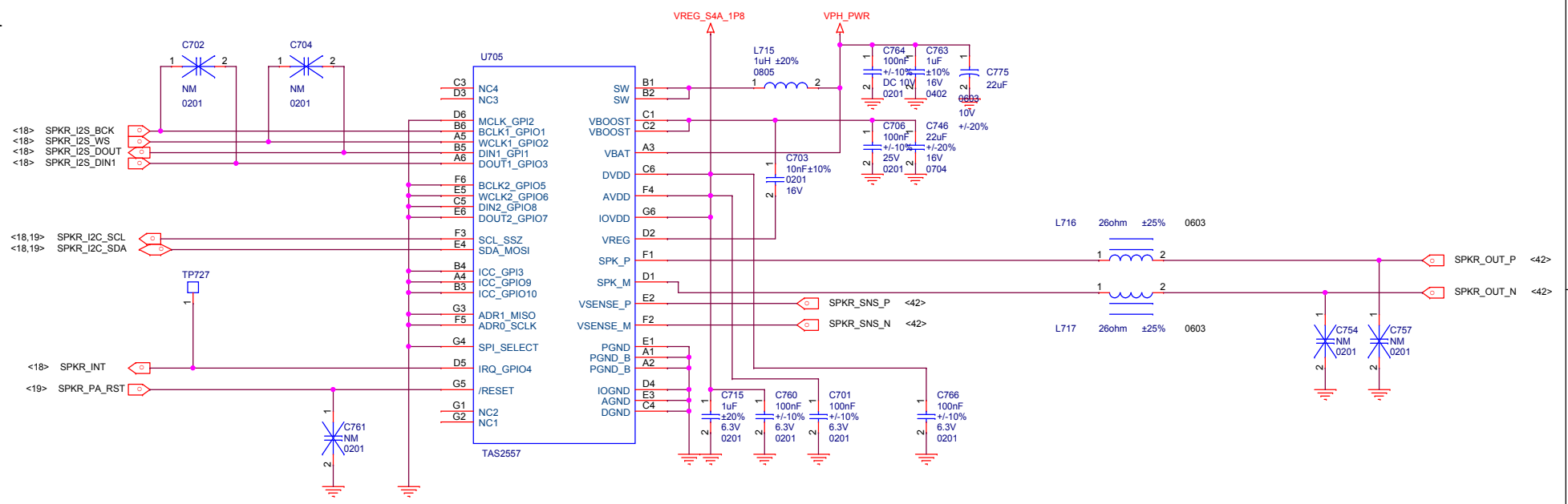

# AUX Mic

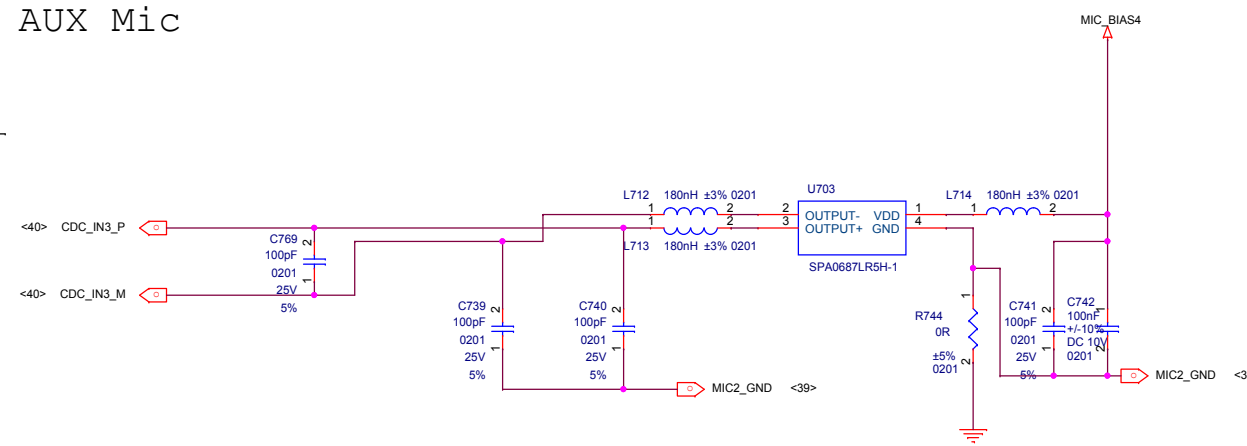

# Receiver

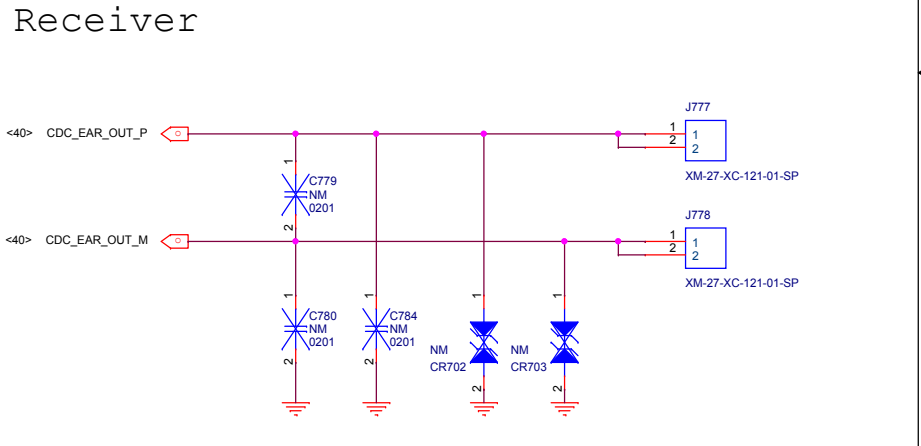

# HEADSET

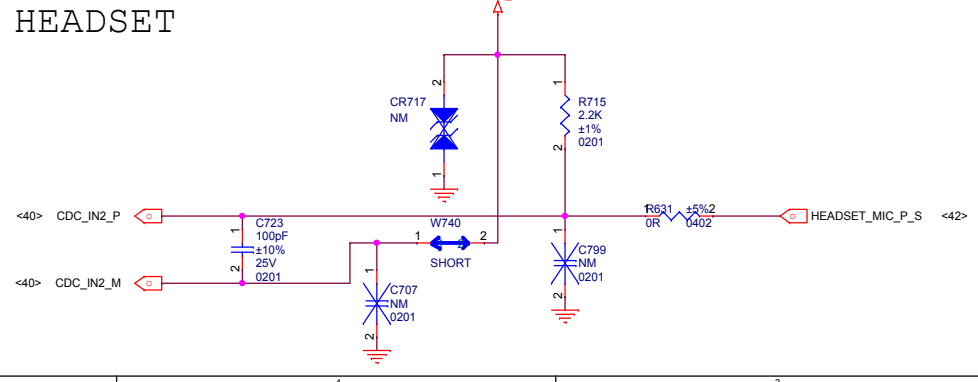

Title		E5	
Size	Document Number	A3	
Date:	Monday, September 03, 2018	Sheet	39 of 45

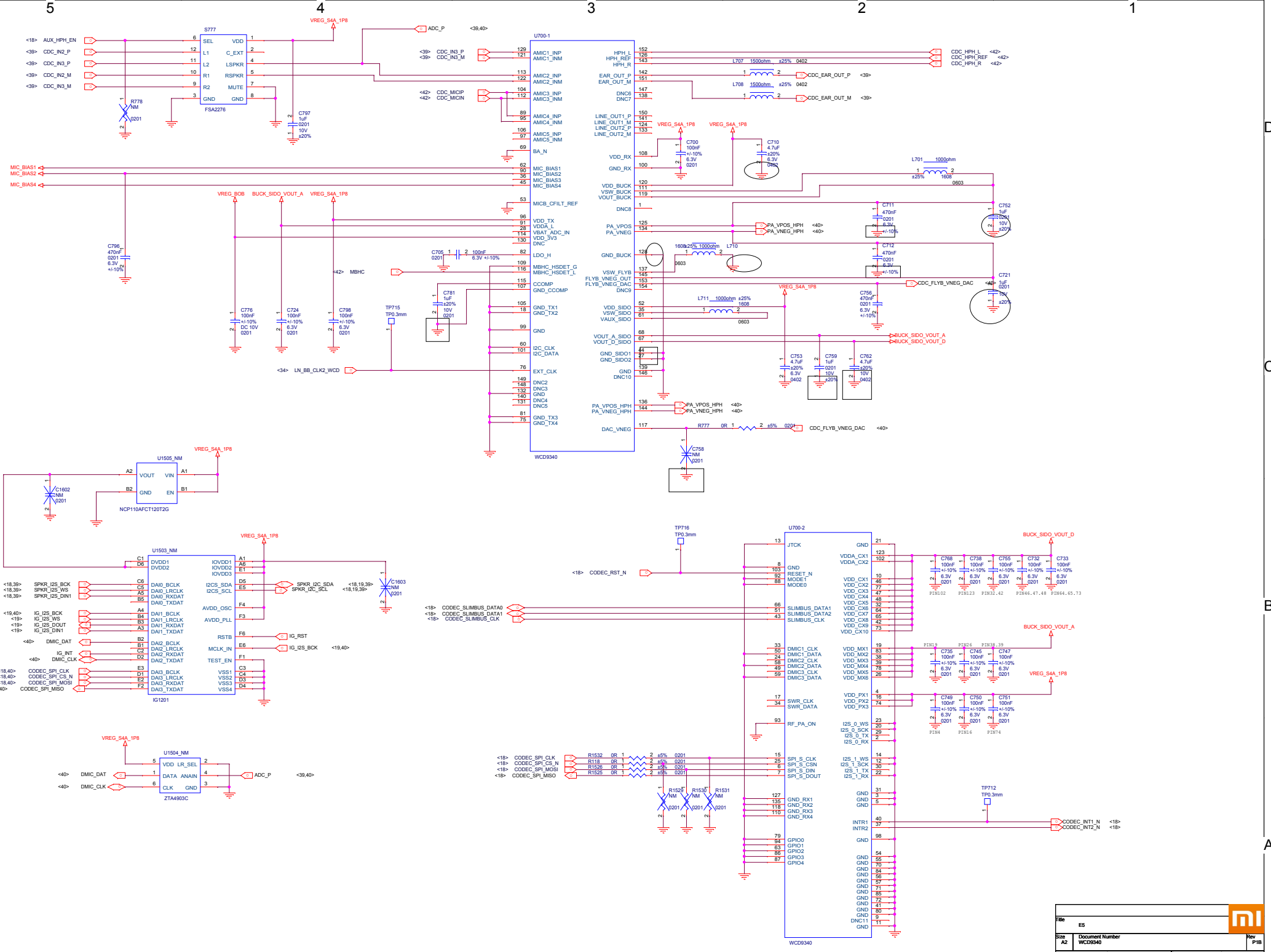

File	E5	
Size	A2	Document Number
Date	Monday, September 03, 2018	WCD9340
		Rev
		P1B
		Sheet
		40 of 45

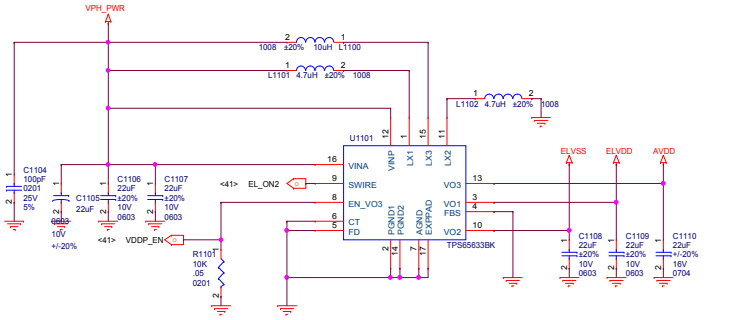
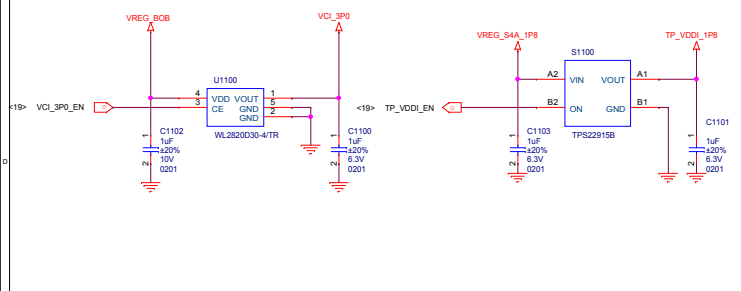

LCD Connector PIN MAP!!!

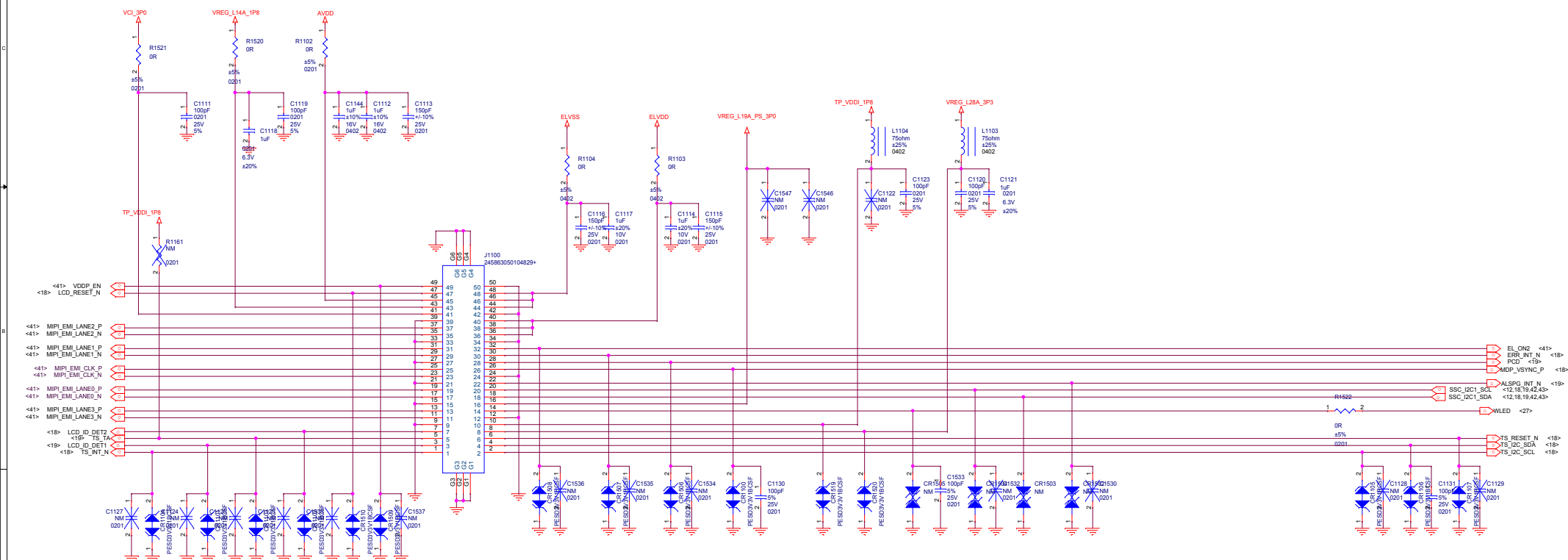
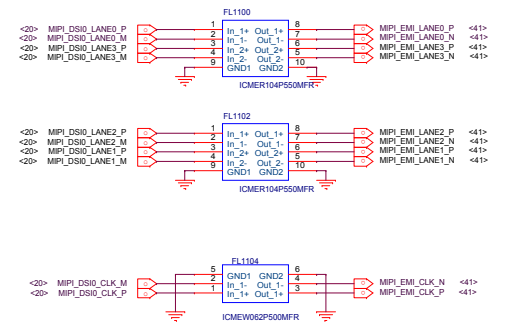

# SIM CONNECTOR

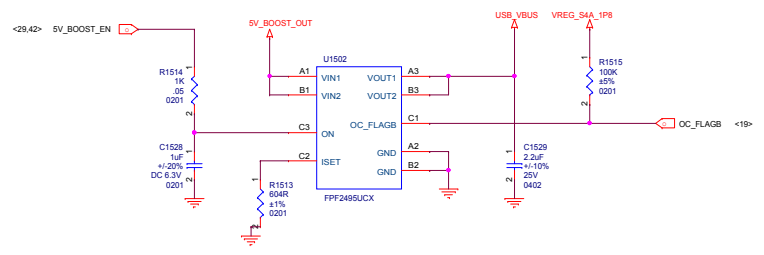
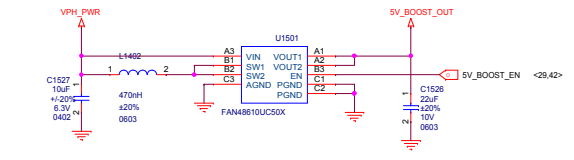
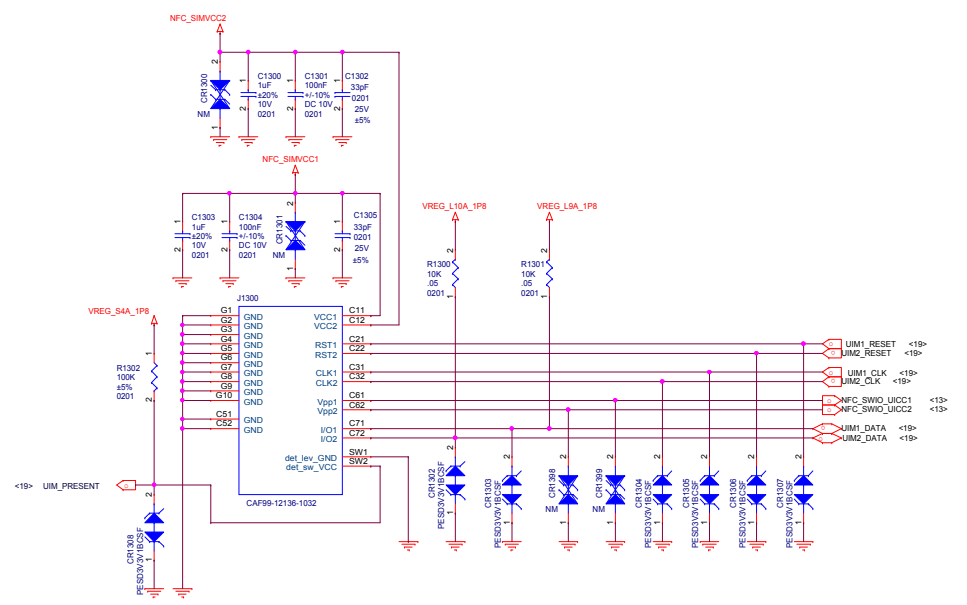

# BTB Connector

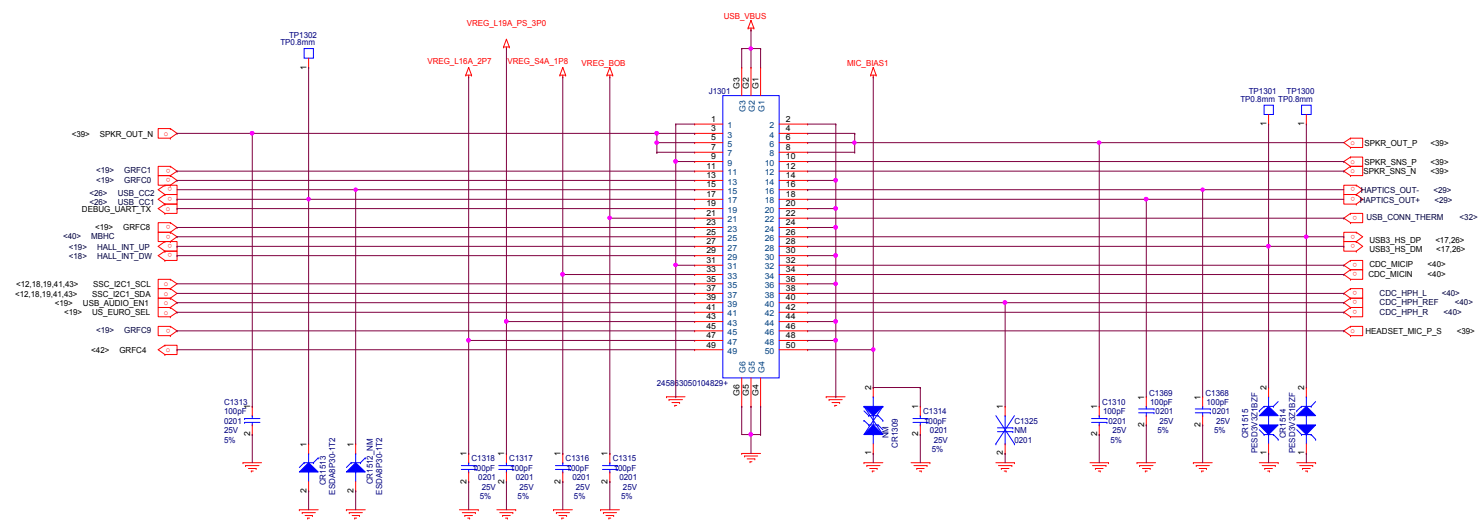
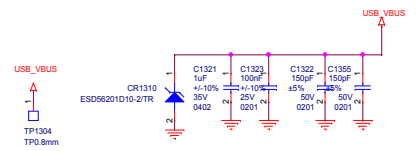

# Fingerprint

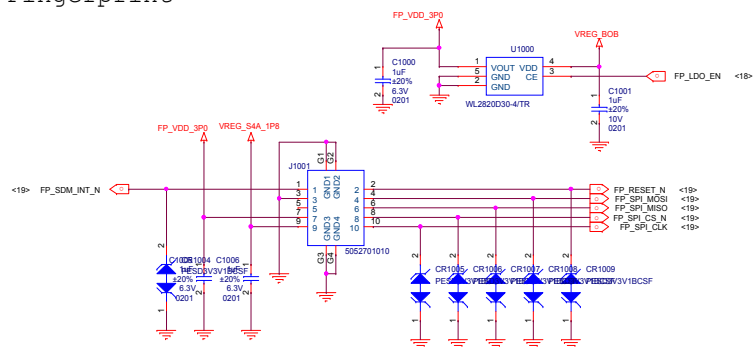

# Side Key

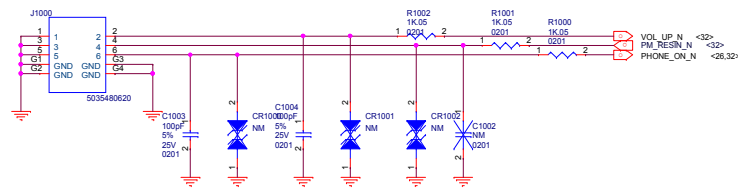

# A+G

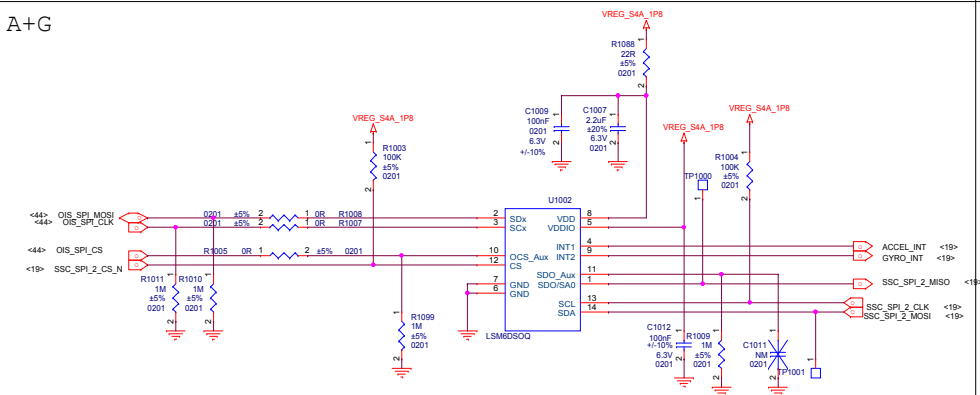

# COMPASS

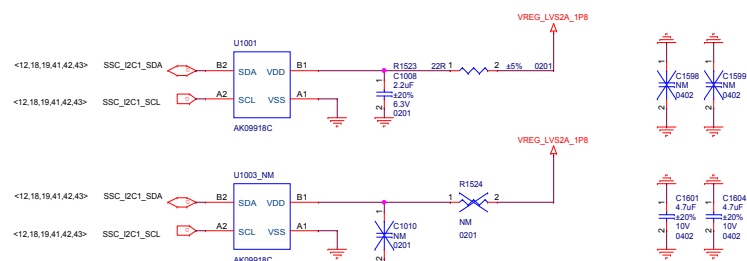

# PRESSURE

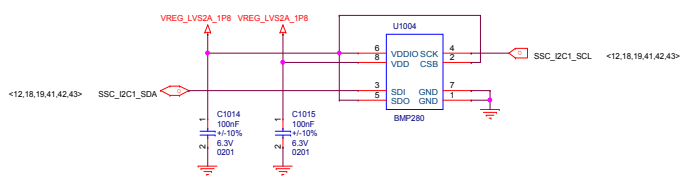

# HALL

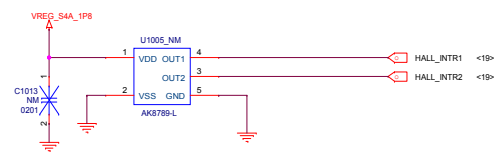

# 小爱唤醒按键

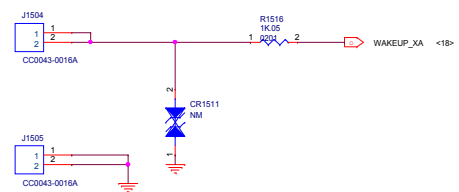

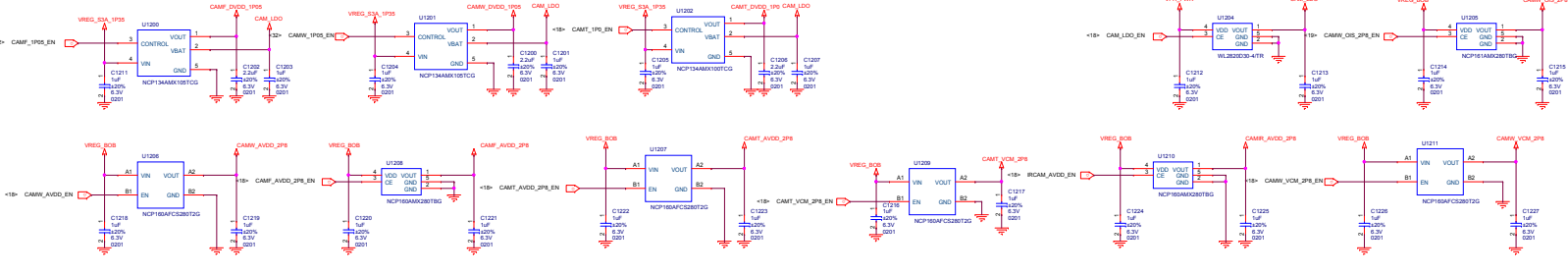

FLASH

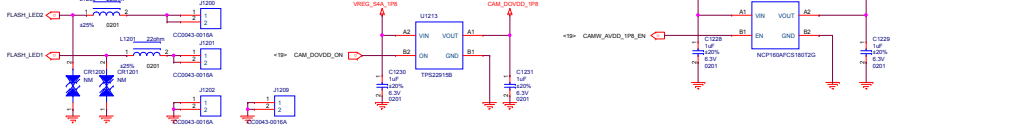

REAR CAMERA

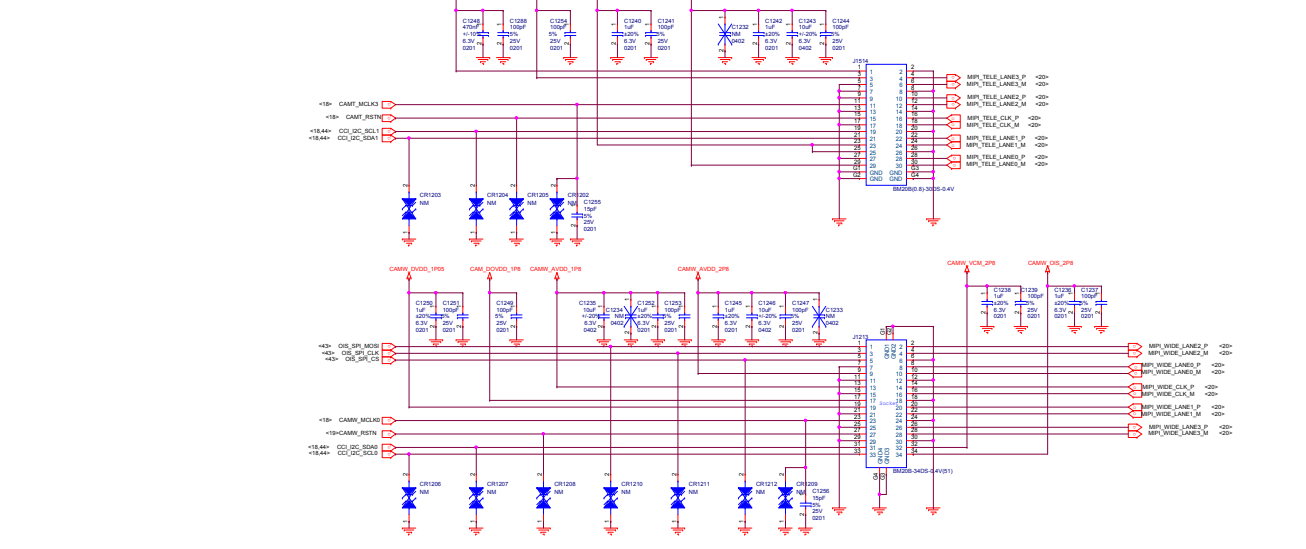

REAR EMI

FRONT CAMERA

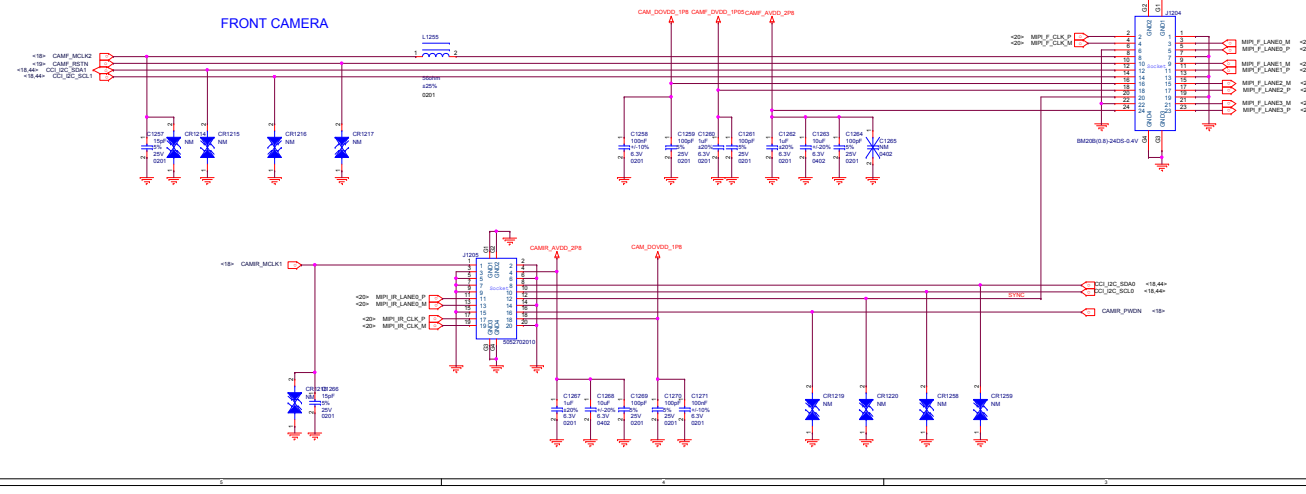

FRONT EMI

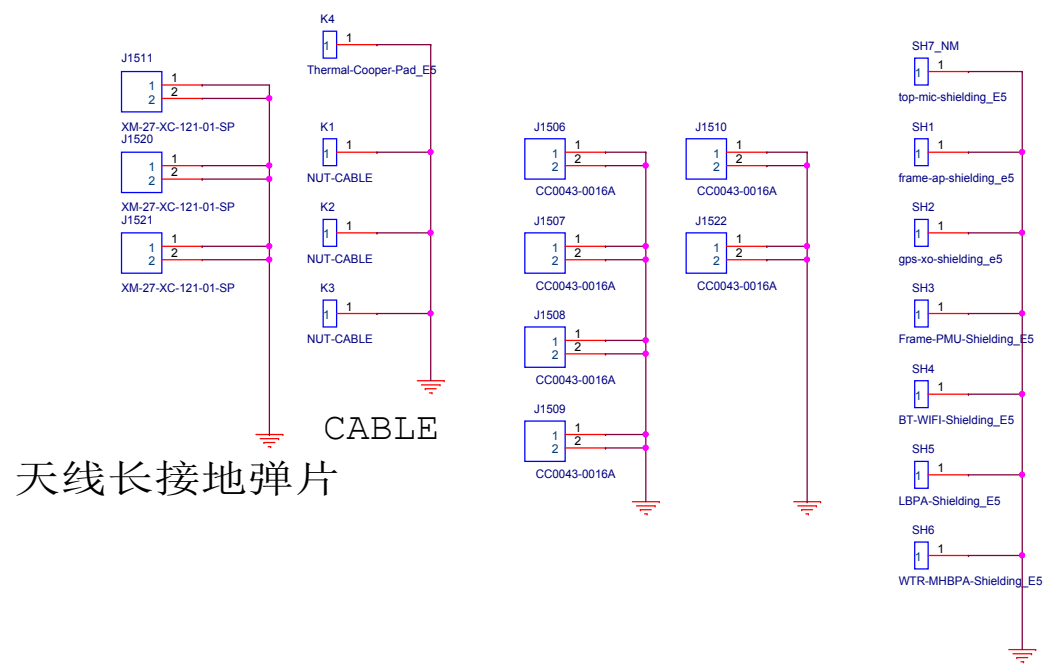
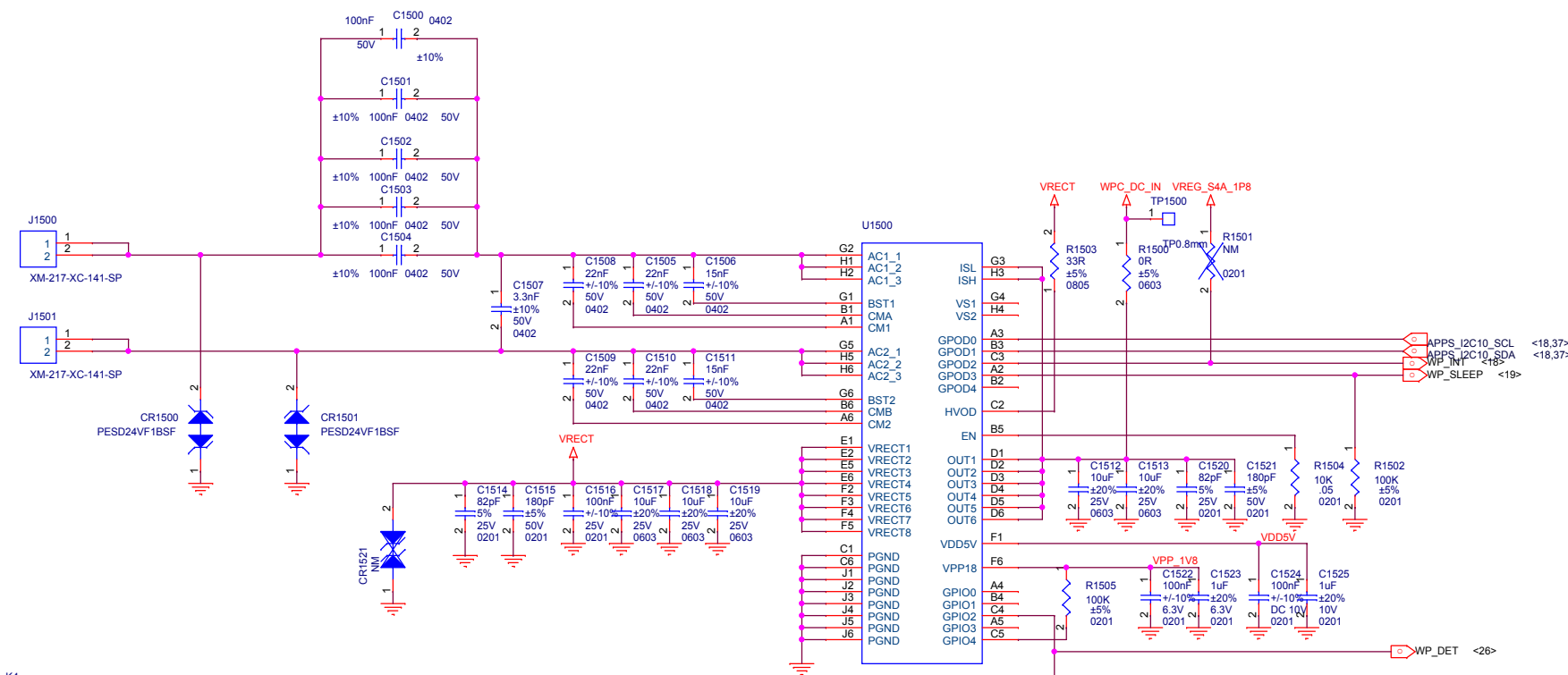

天线上接地弹片

CABLE

VIETMOBILE.VN

Title		E5
Size	Document Number	Rev
A3	P9229_WIPOWER	P1B
Date:	Monday, September 03, 2018	Sheet 45 of 45