

Top-level Diagram

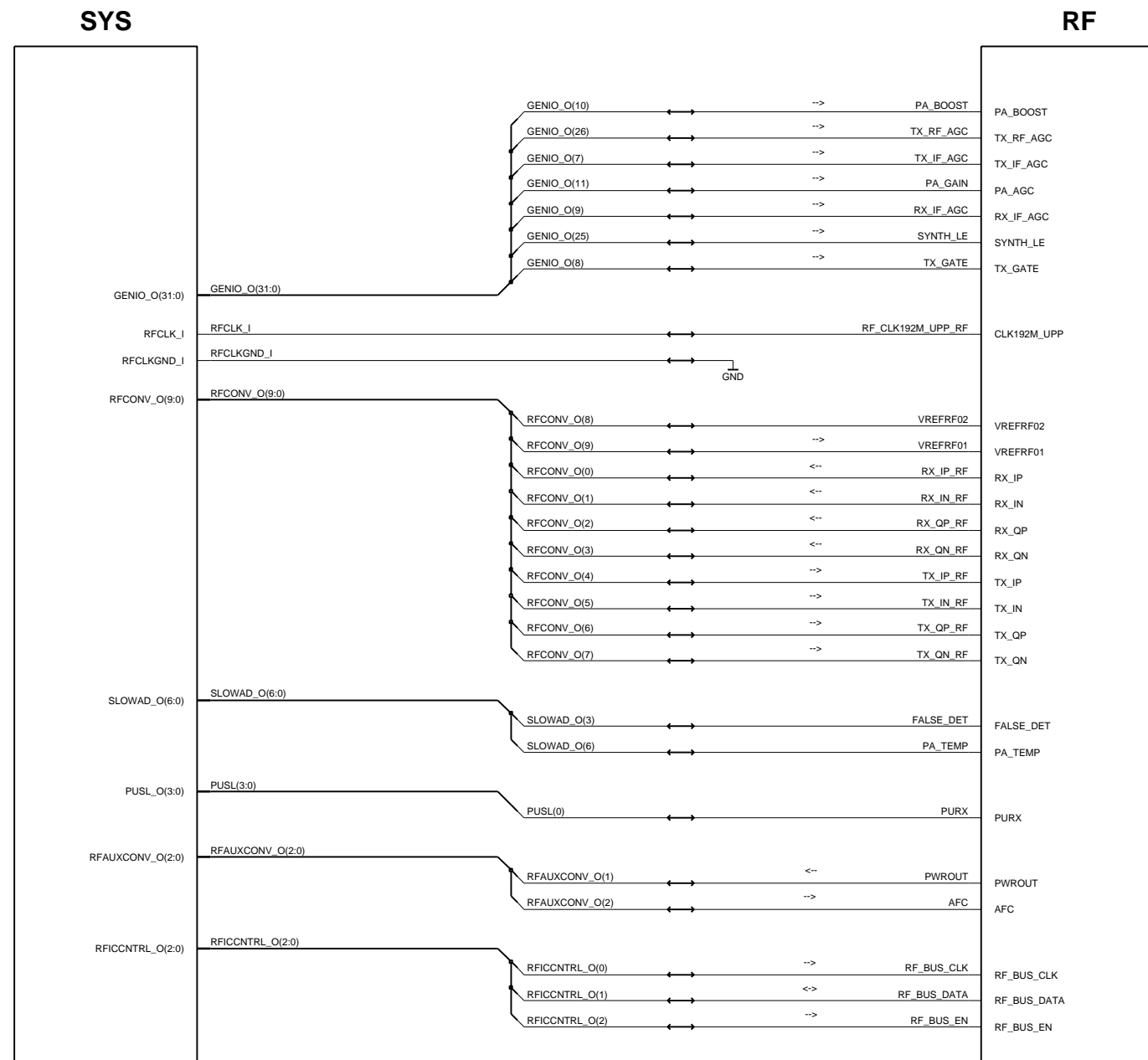

RF Top-level Diagram

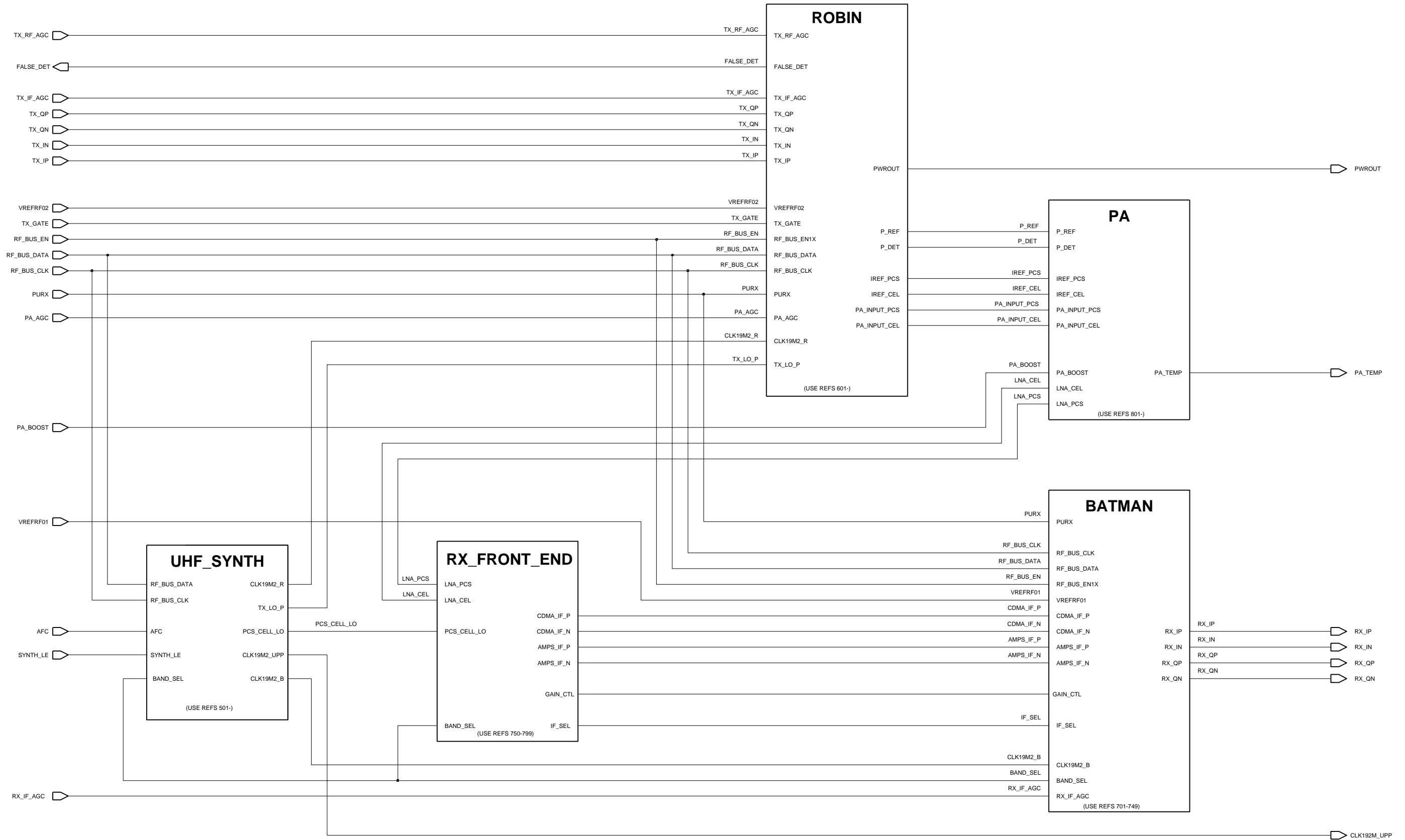

PA

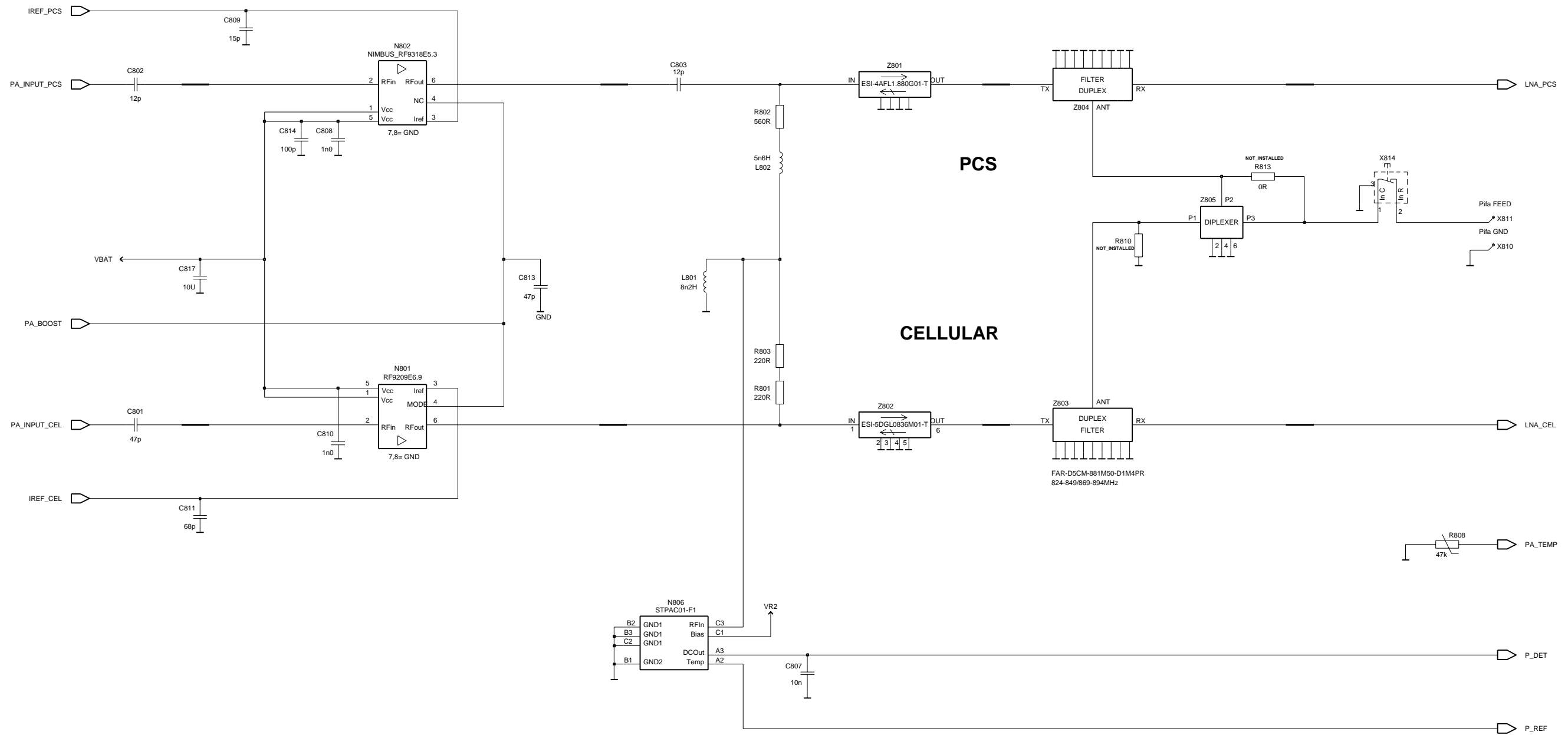

Robin

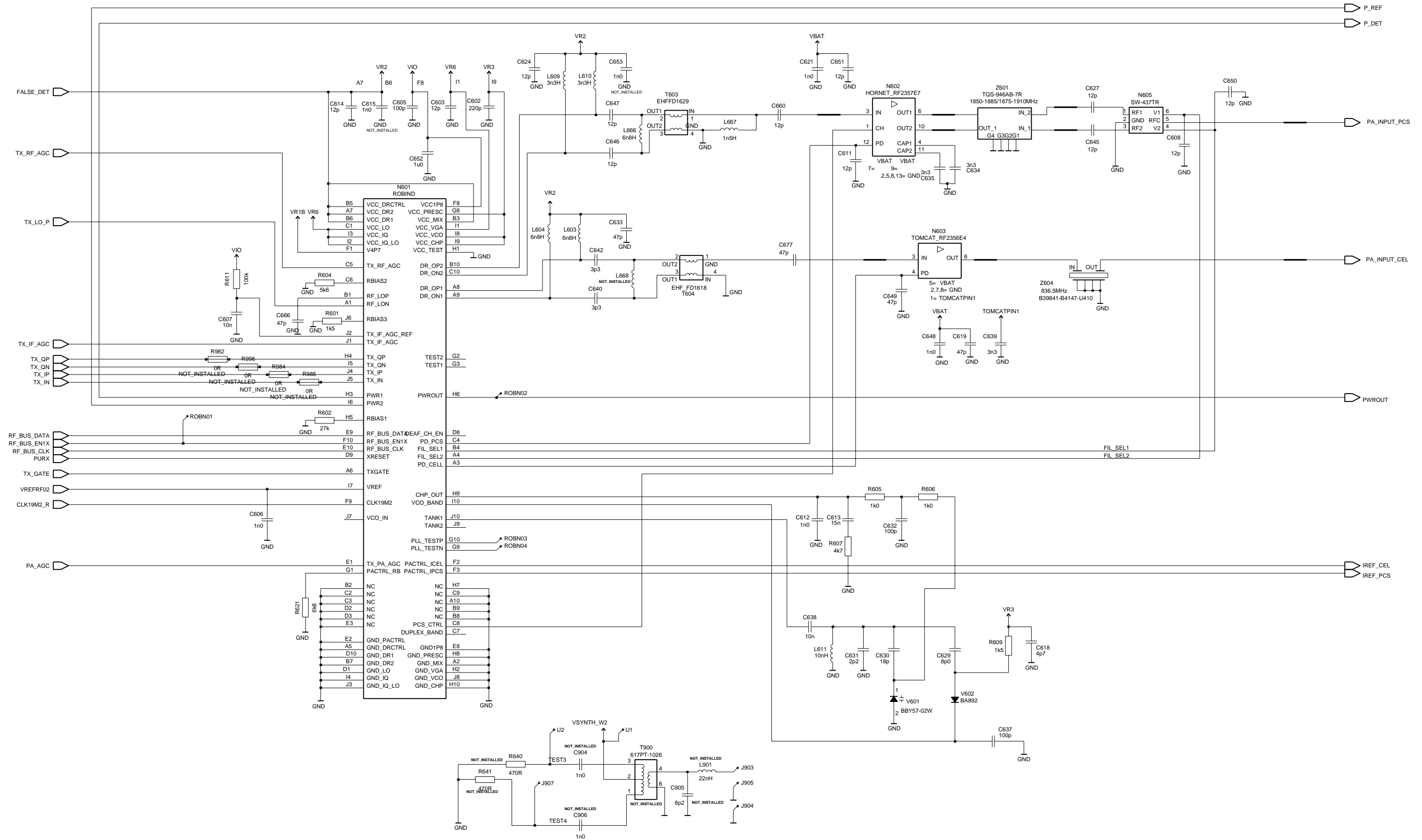

Truth Table for Split Band Filter DATA

Front End

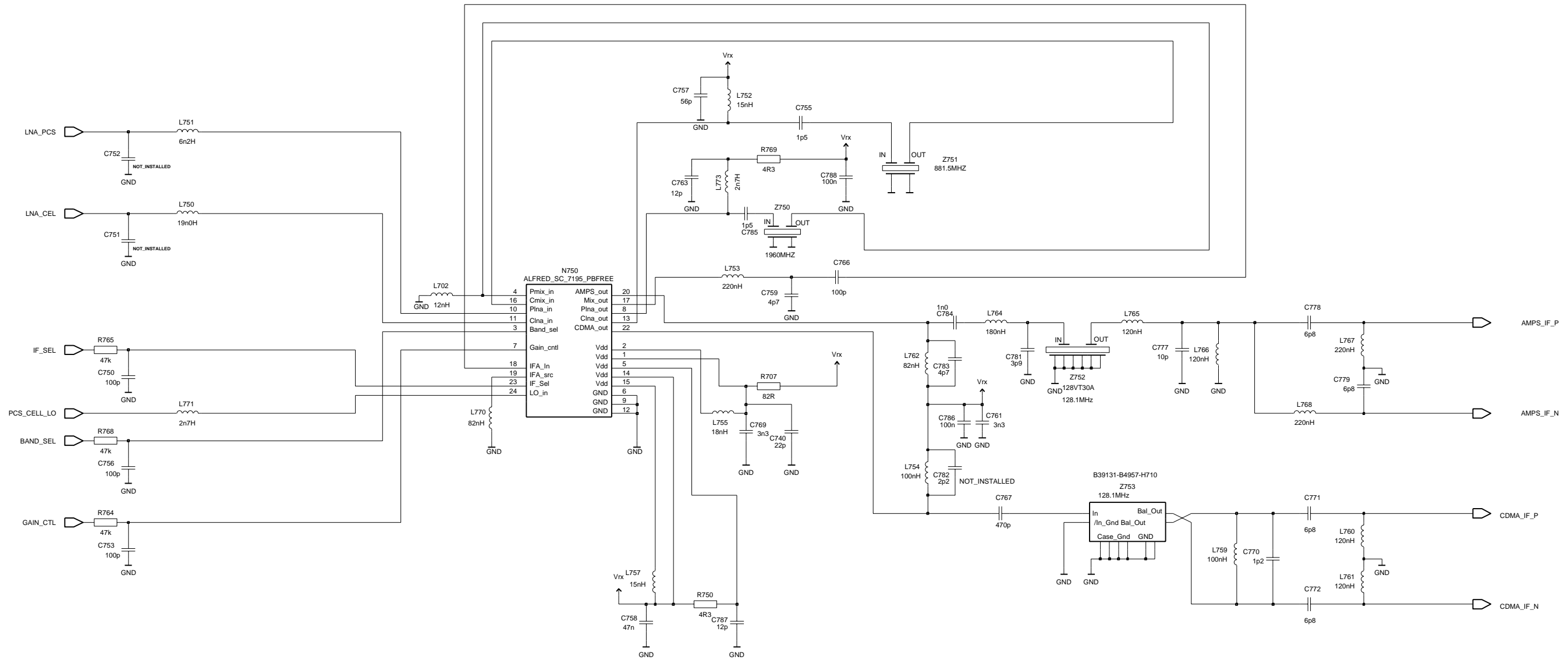
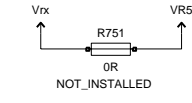

MODES	LOGIC INPUTS		
	BAND	GAIN_CTL	IF_SEL
CEL CDMA Hi Gain	0	1	0
CEL CDMA Lo Gain	0	0	0
PCS CDMA Hi Gain	1	1	0
PCS CDMA Lo Gain	1	0	0
AMPS Hi Gain	0	1	1
AMPS Lo Gain	0	0	1

UHF Synthesizer

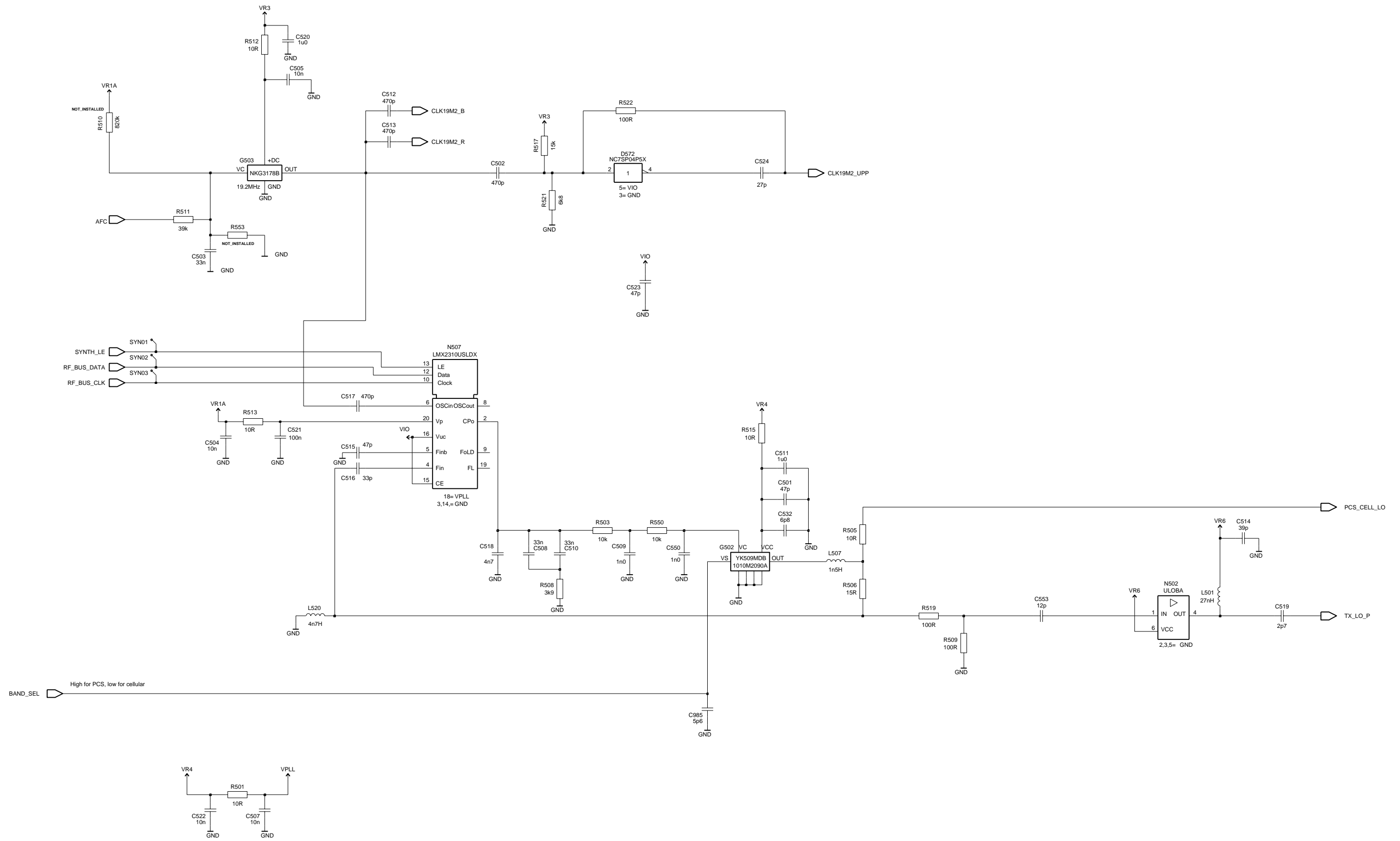

Batman

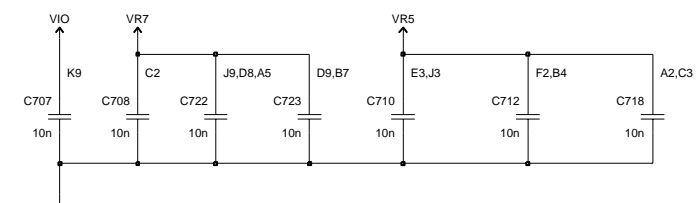
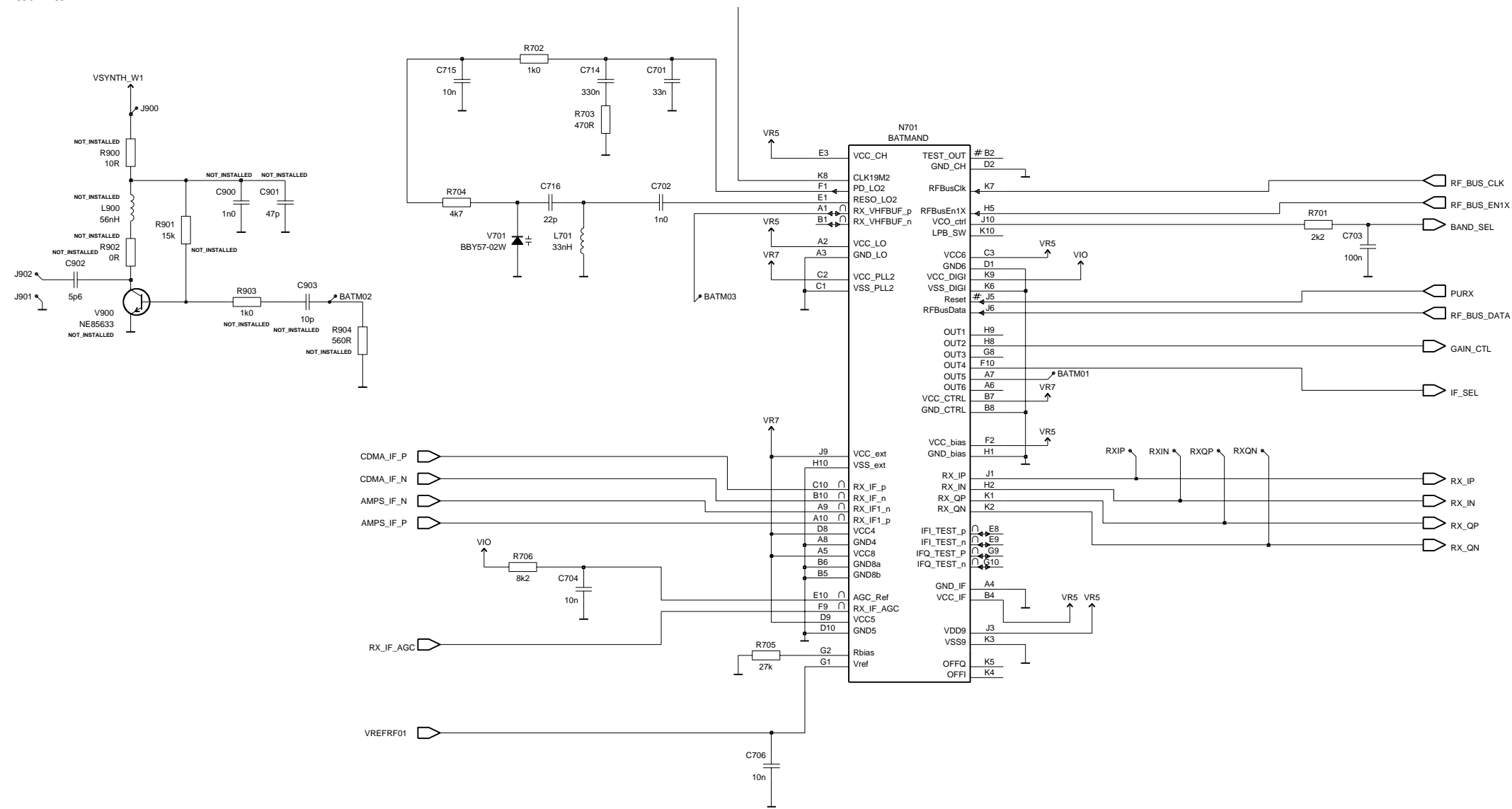

System Module

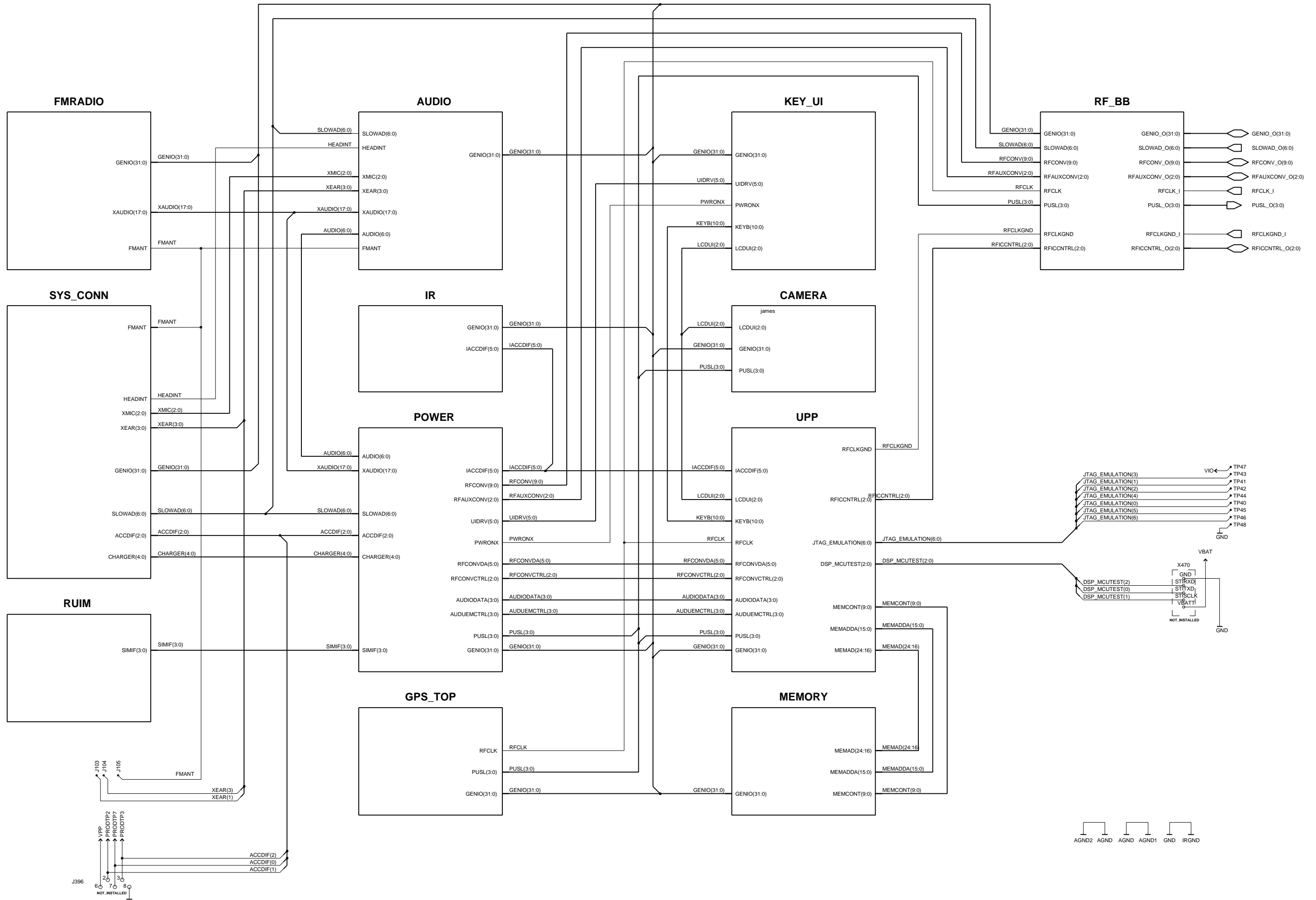



IR Module 1.8V

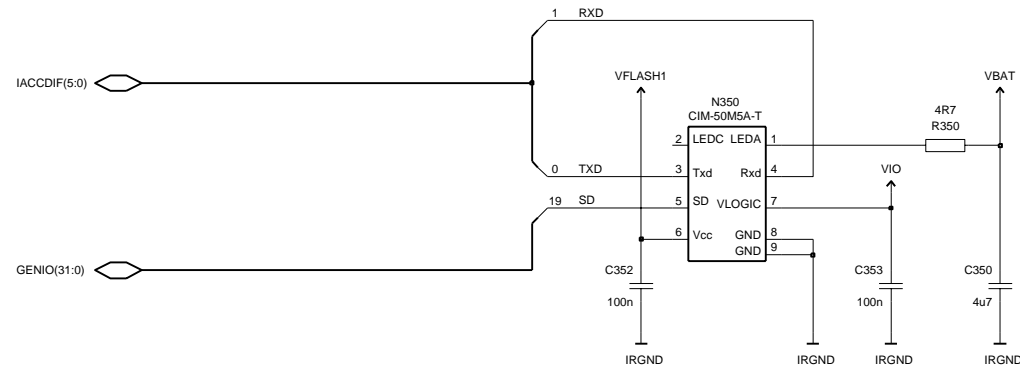

Camera

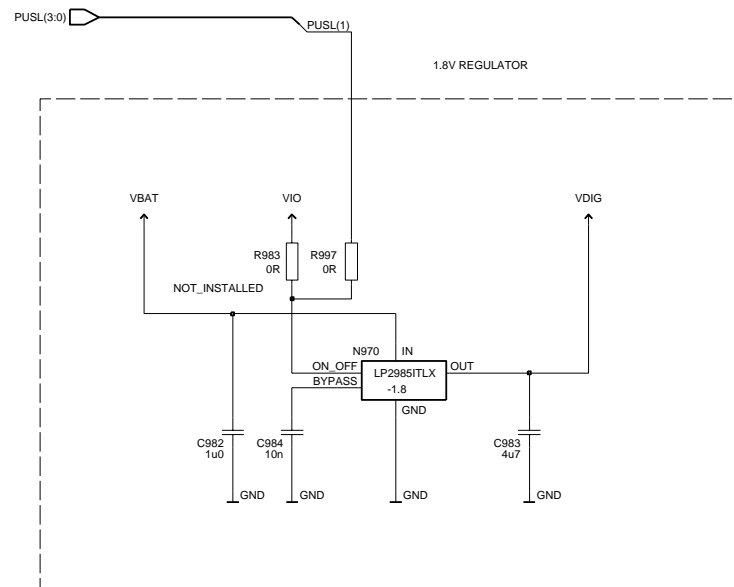
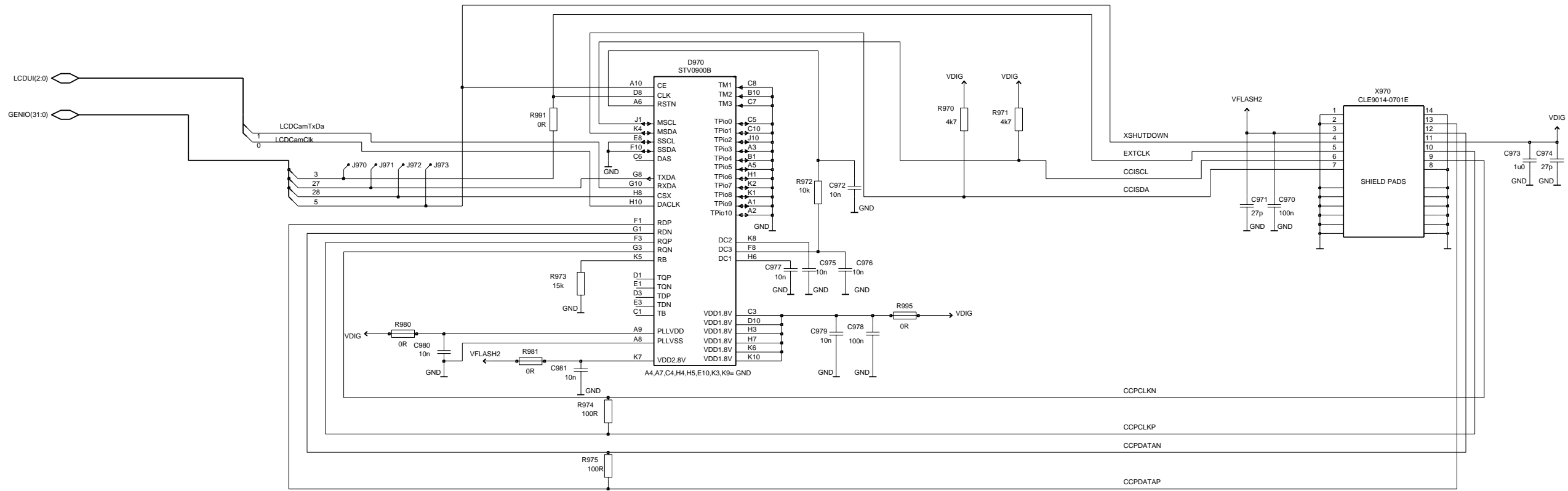

AMD 64 Mbit (Burst Read/Write)

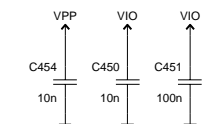
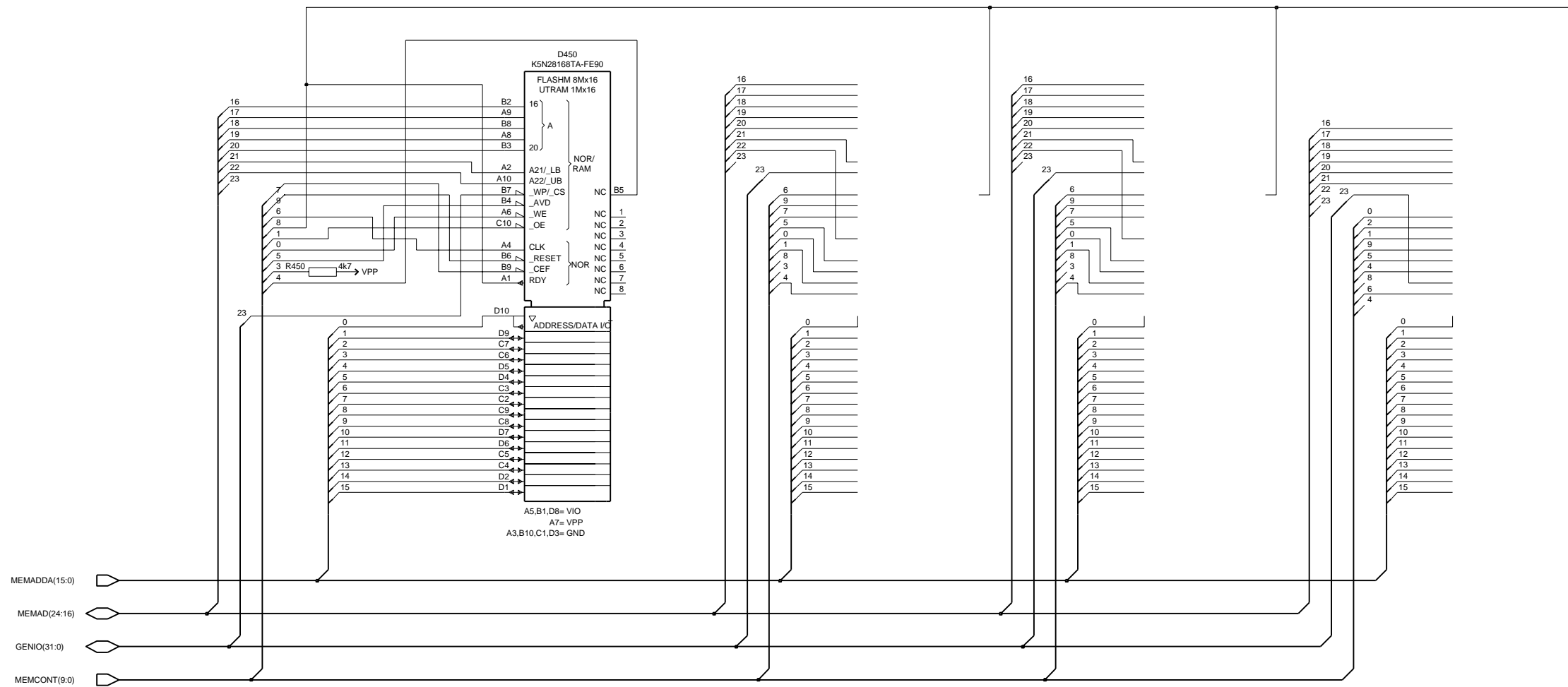

User Interface

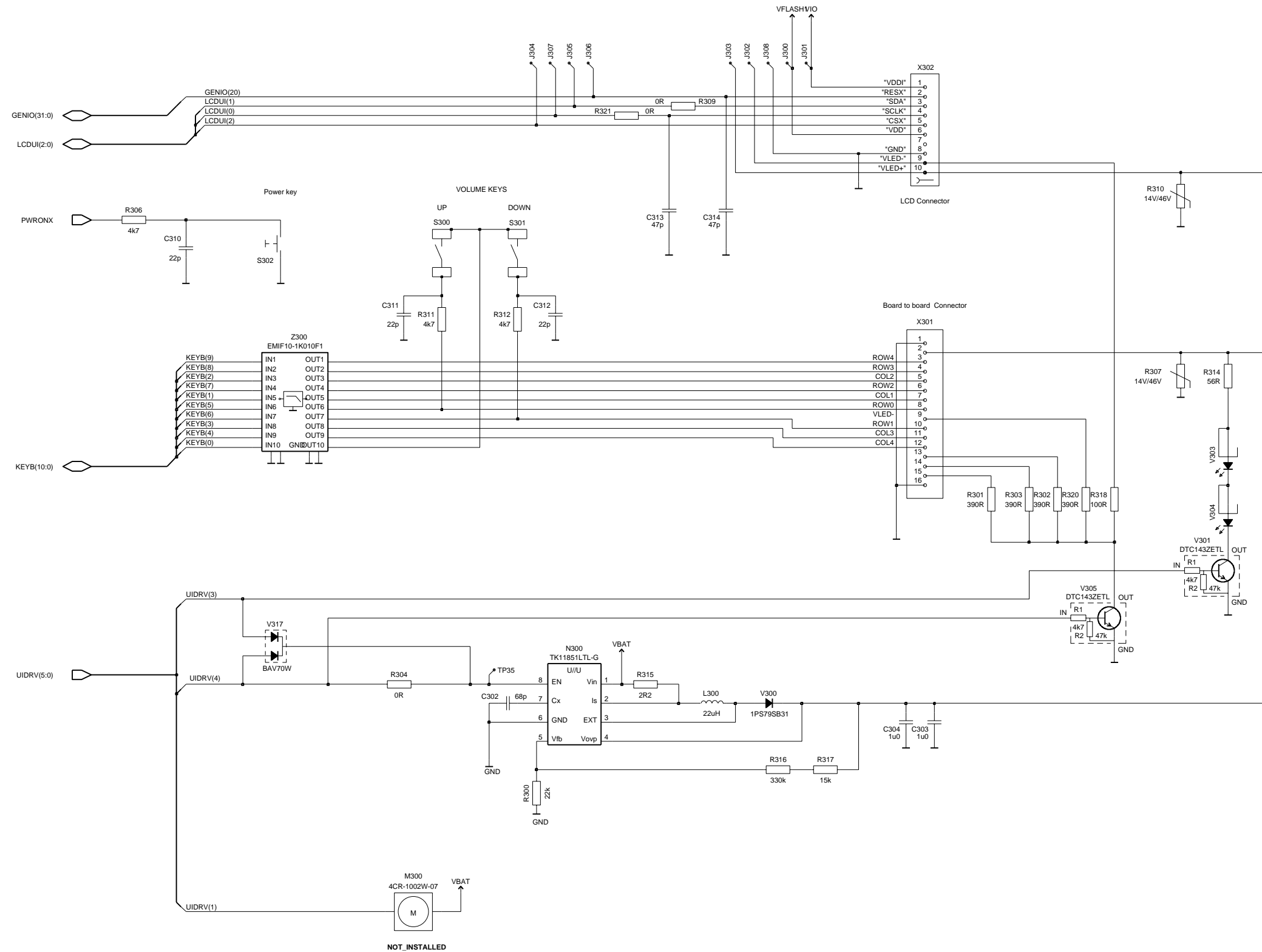

System Connector

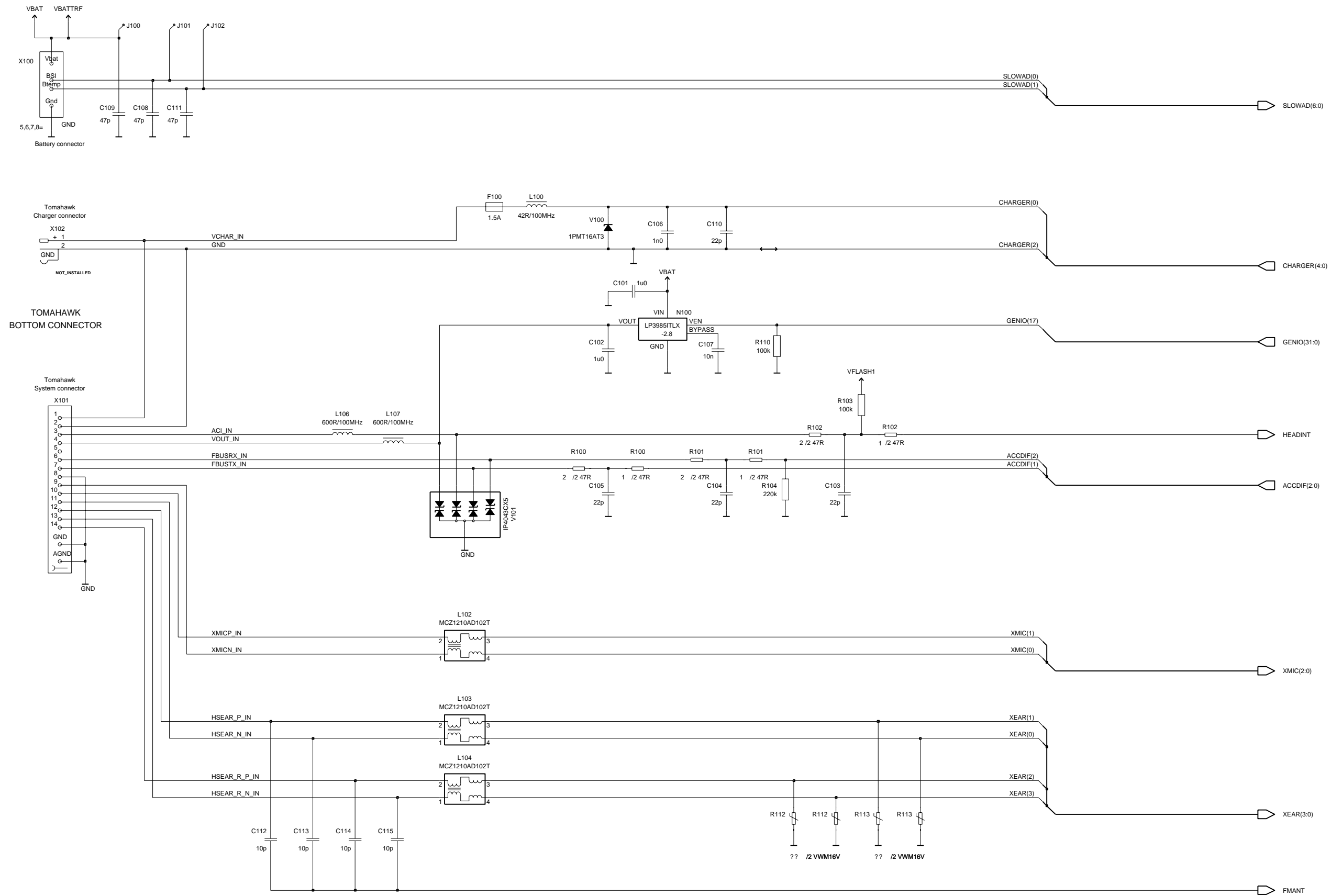

High-Density 1.8V

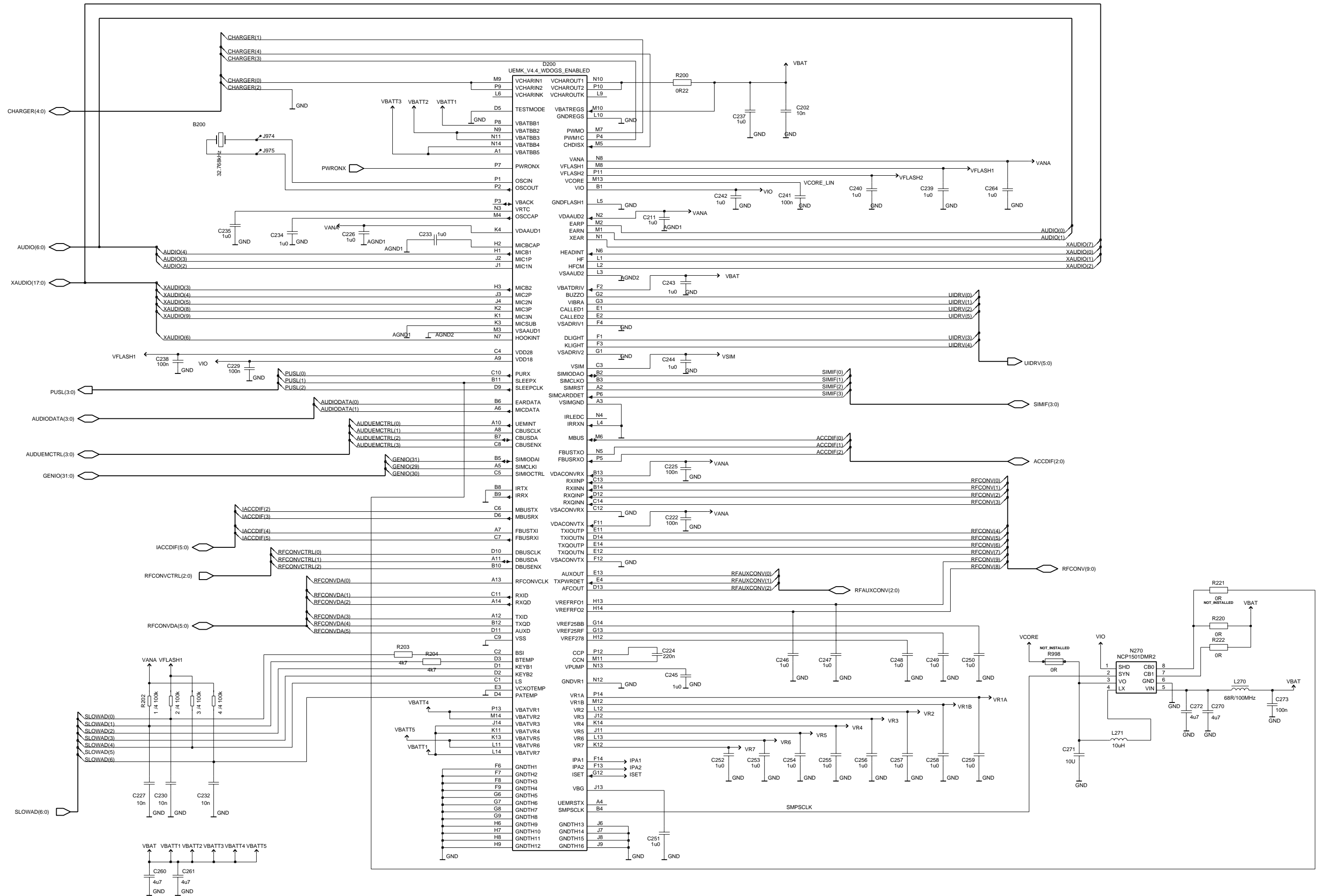

**SIM Reader**

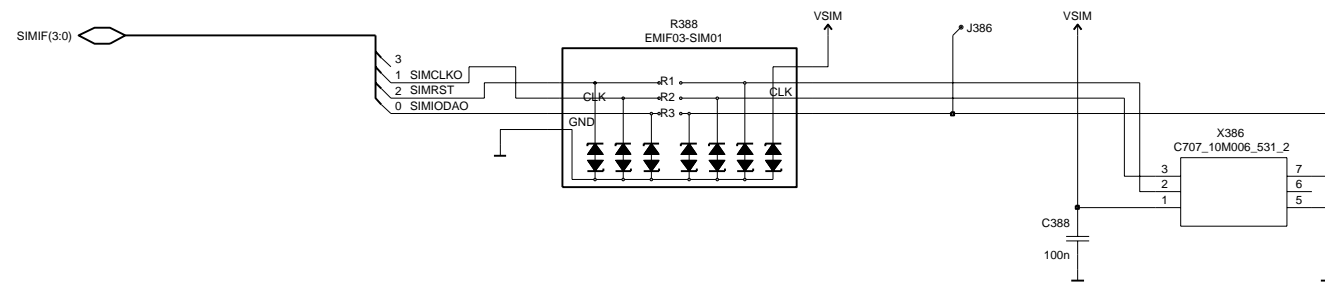

**GPS RF BB Interface**

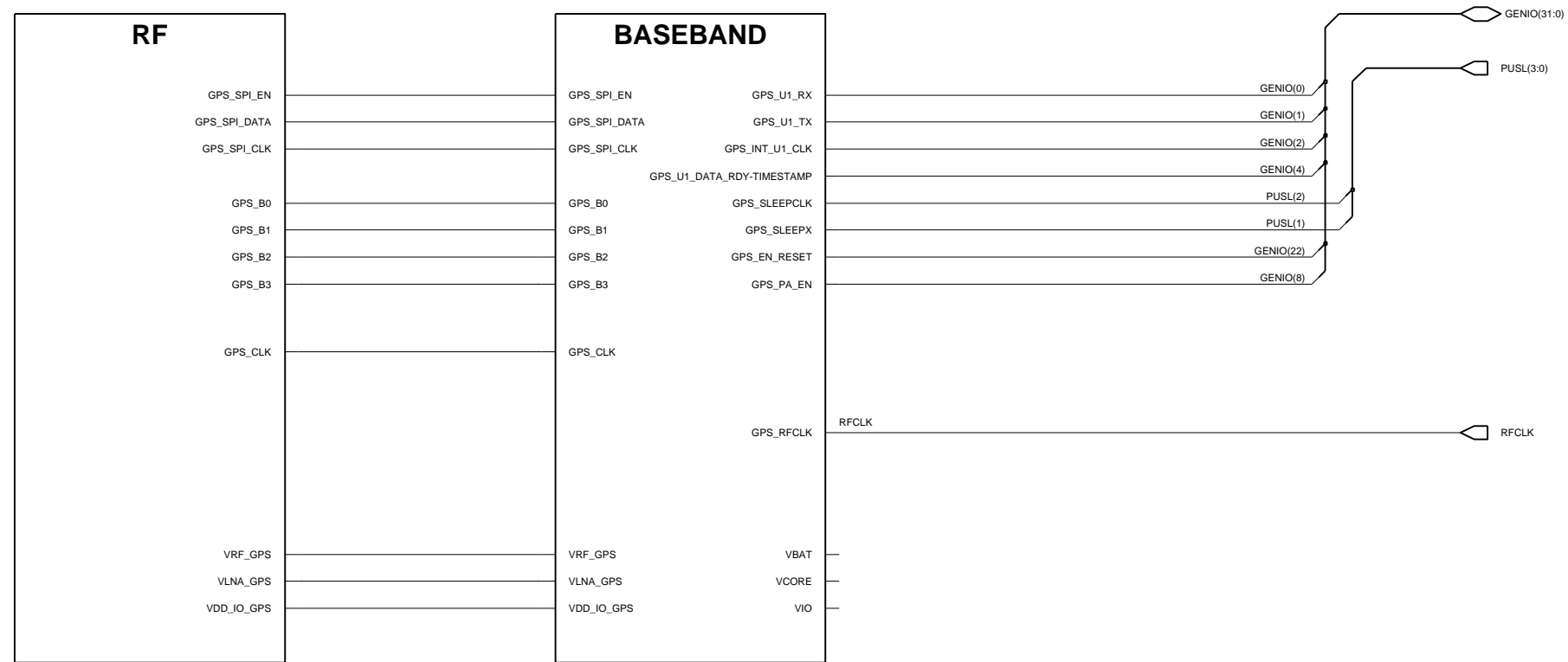

Audio

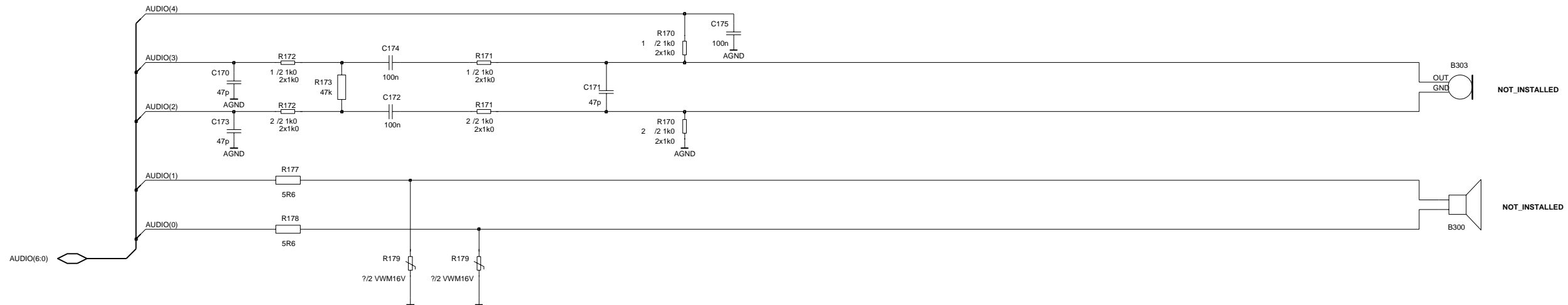
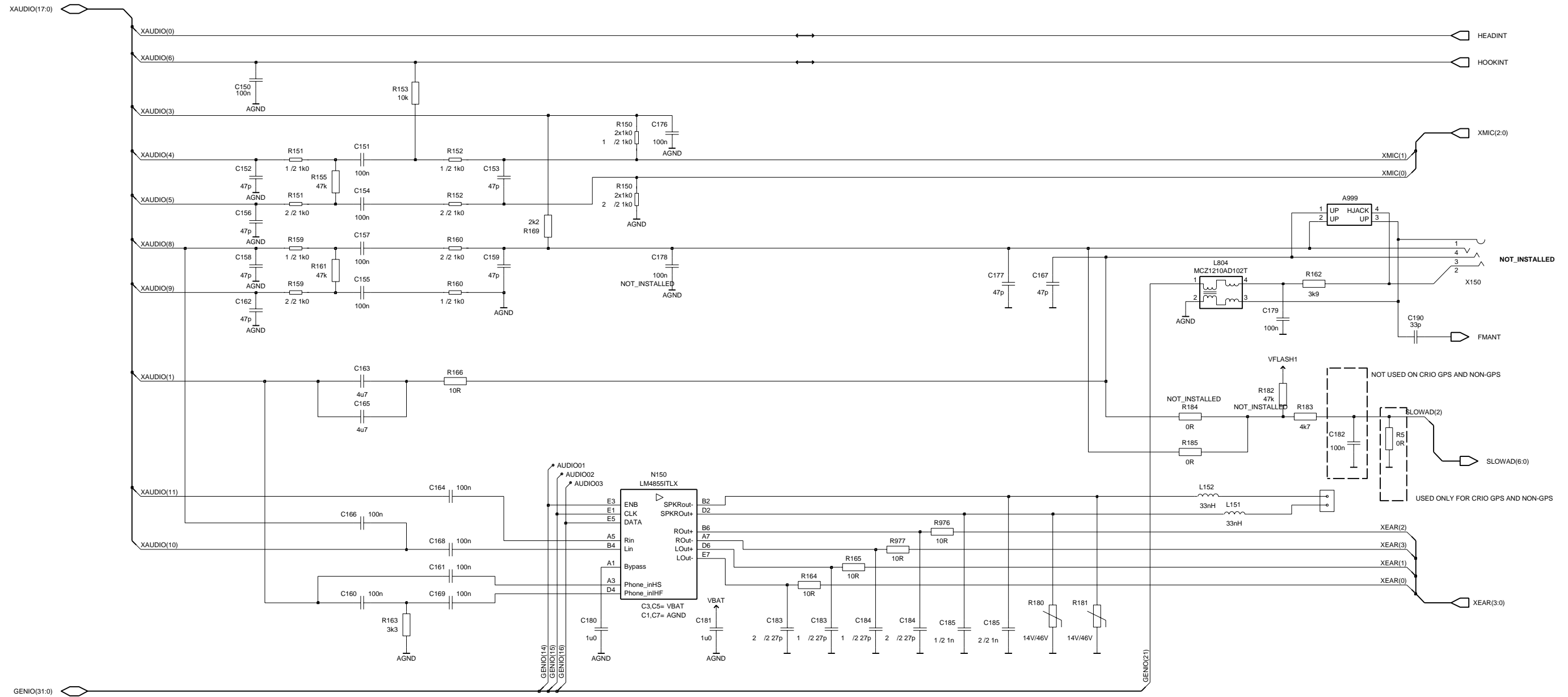

GPS Baseband Circuit Diagram

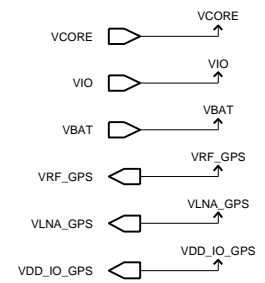
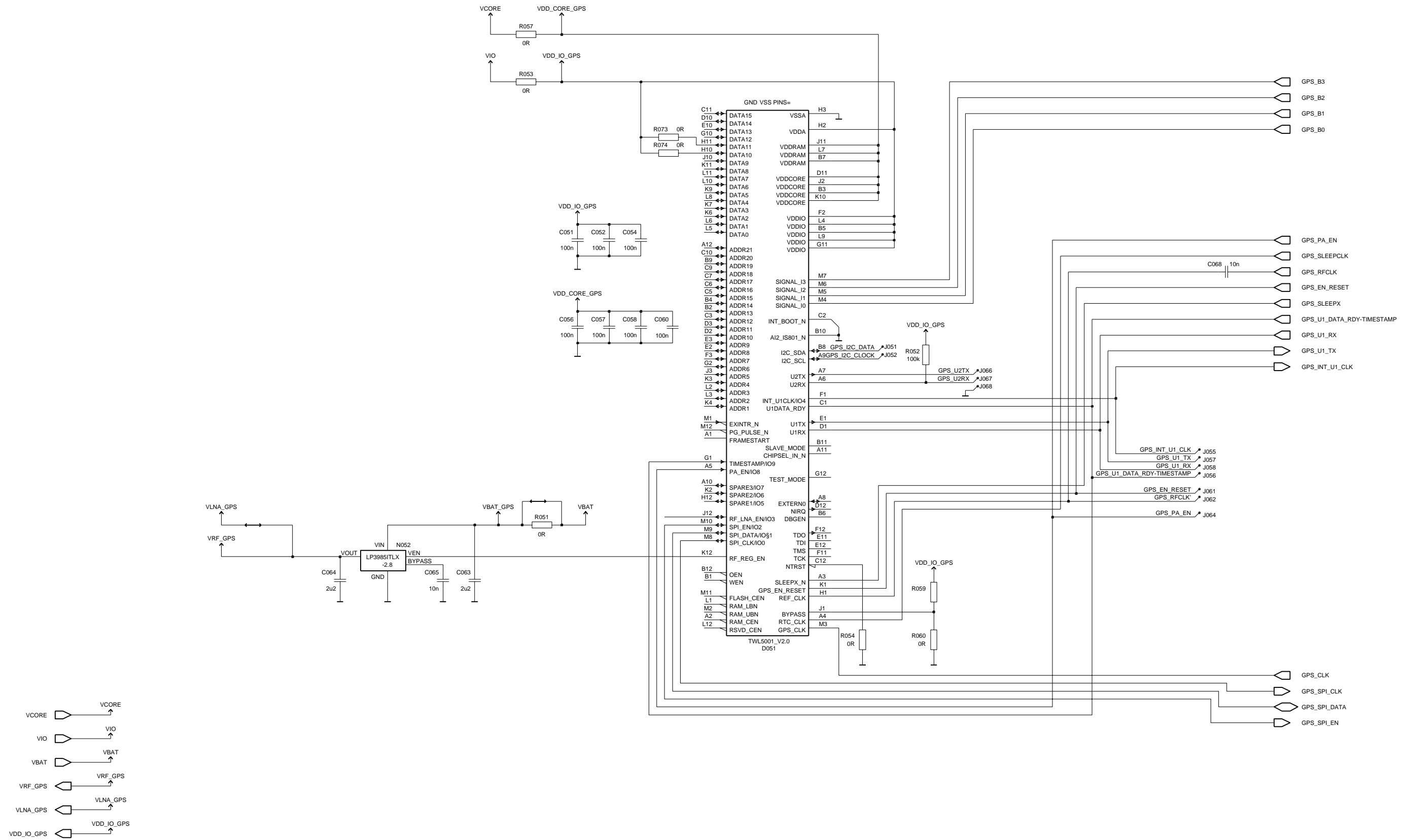



GPS RF Circuit Diagram

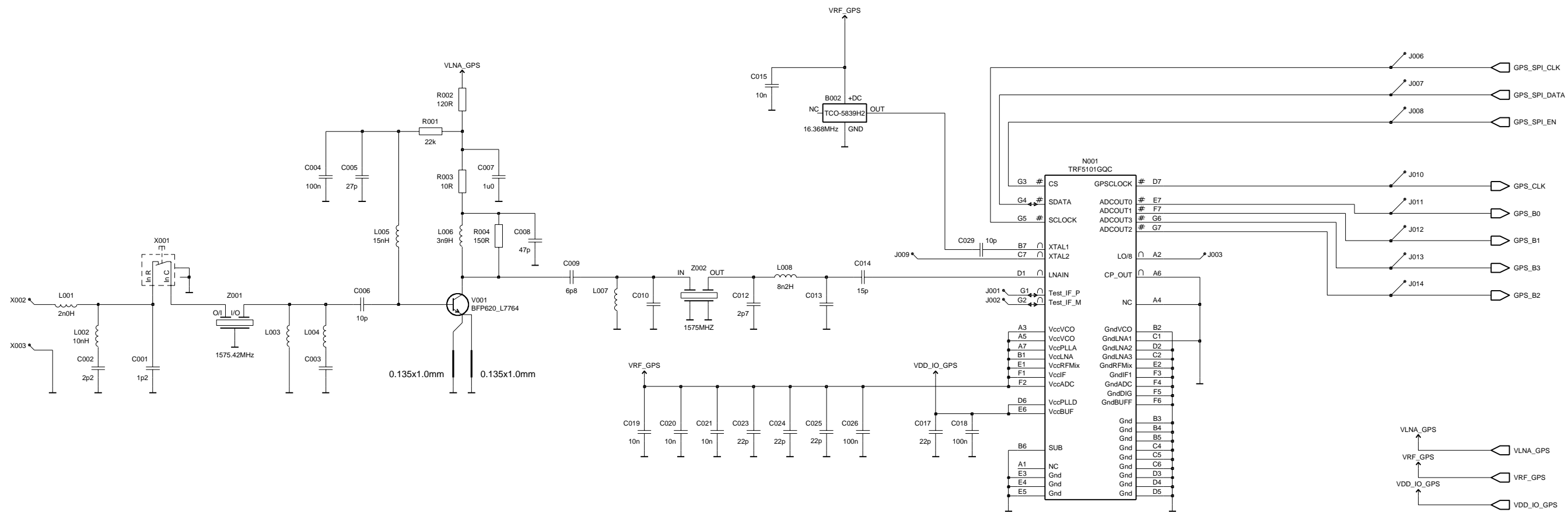

TEA5767 FM Radio Unit

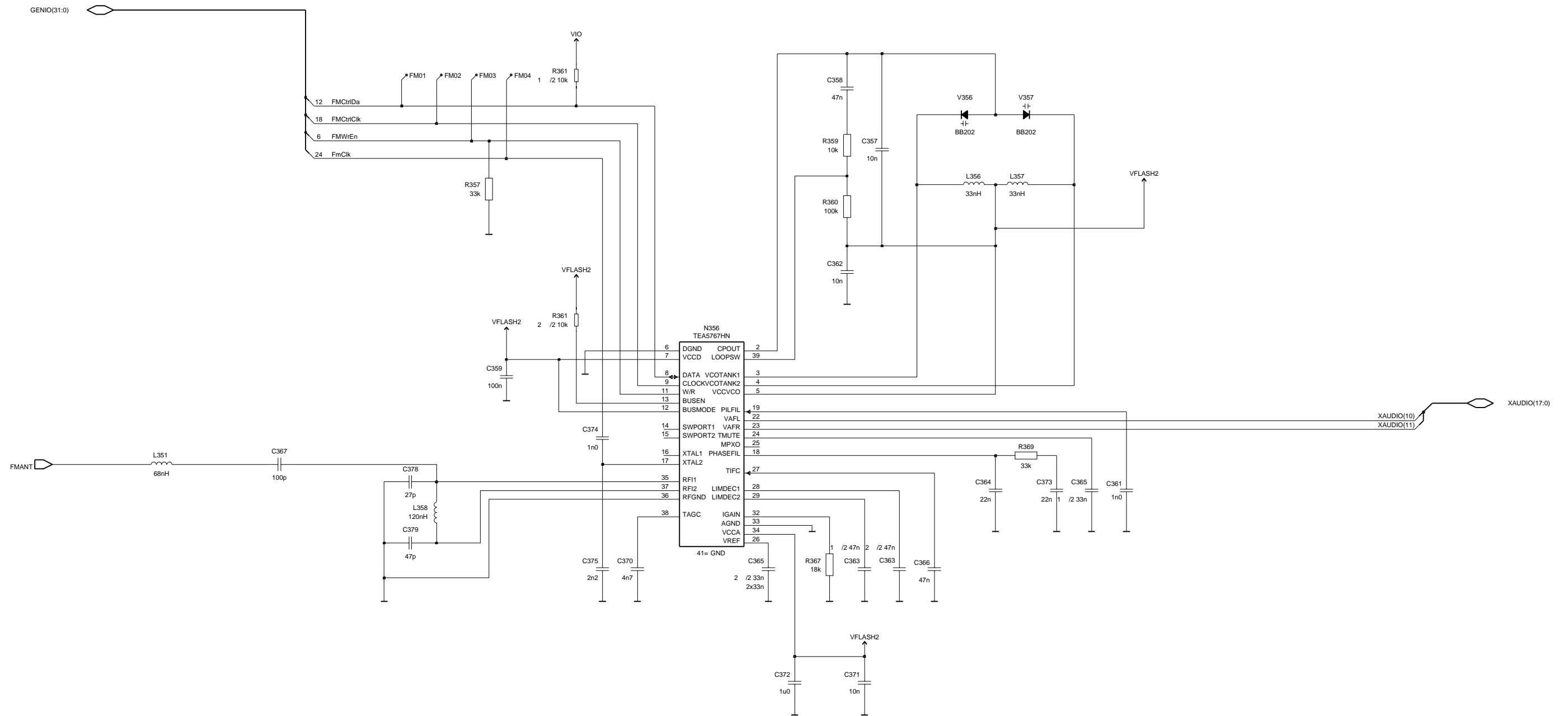

Notice:  
 C374 (1n0) and C375 (2n2) are configured for 32kHz reference clock  
 If reference clock is 6.5MHz, use C374 (3p9) and C375 (10p)

BB-RF Interface

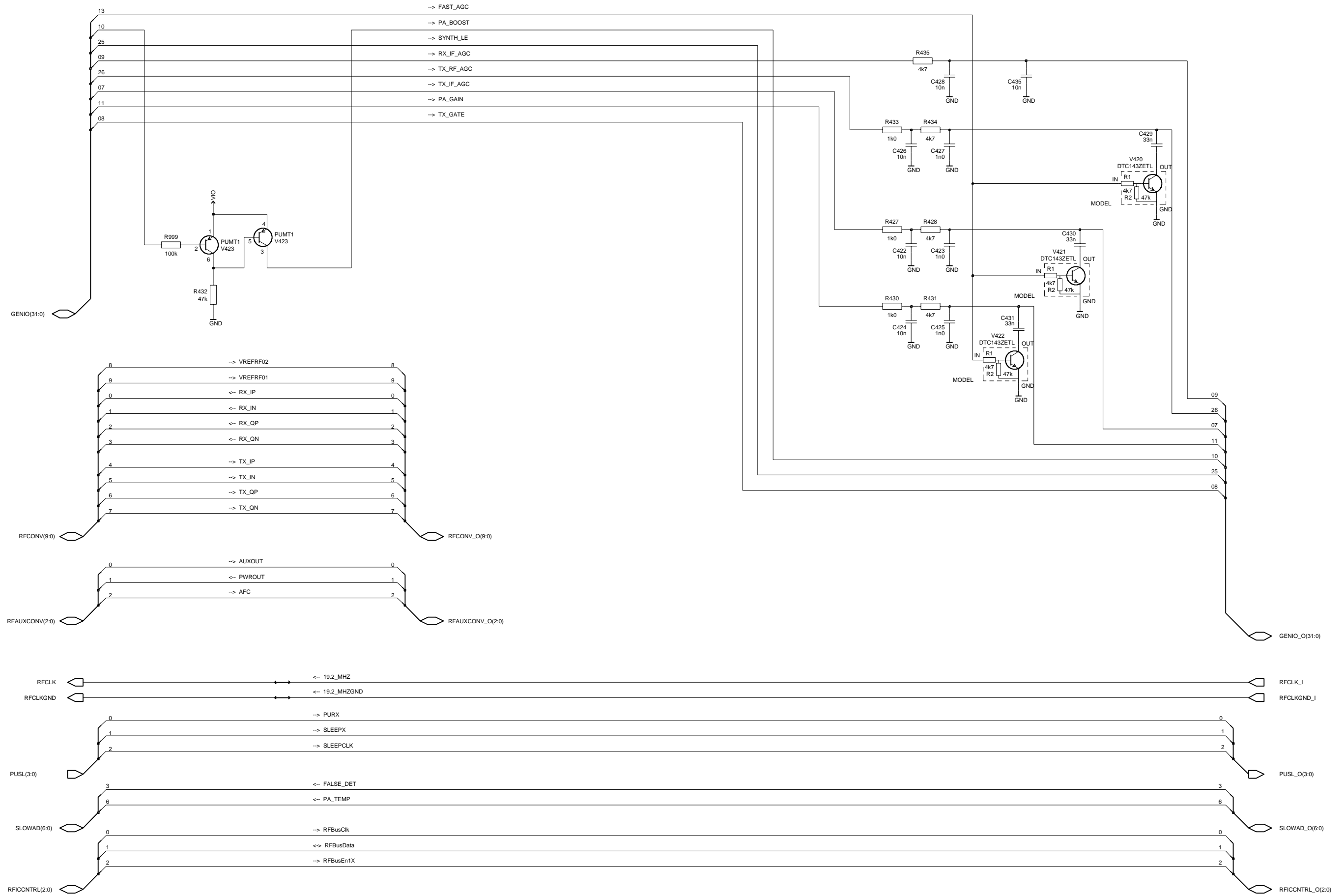

UPP 8M Implementation

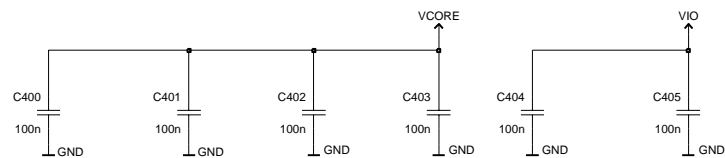
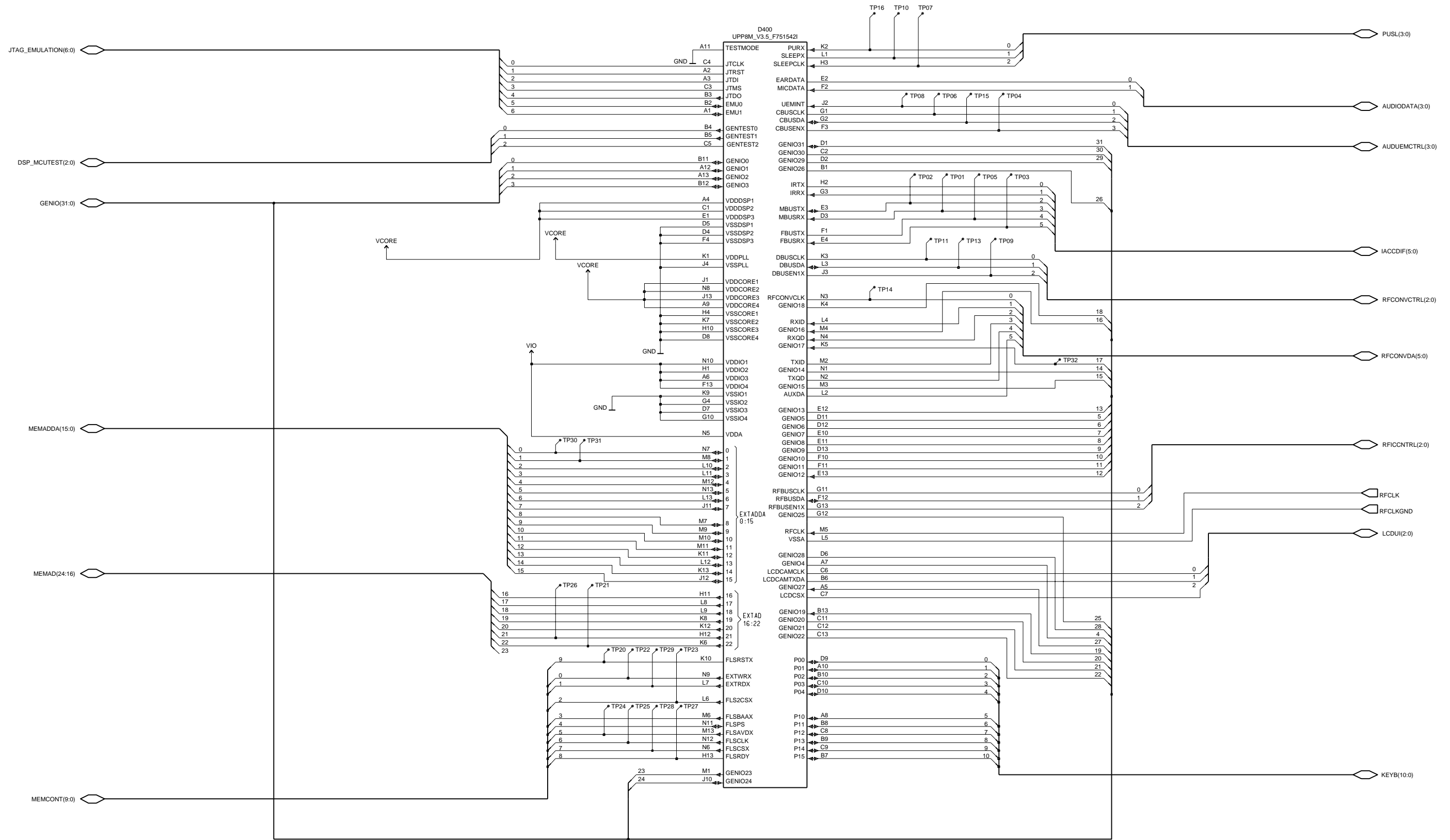

Component Layout — Top View

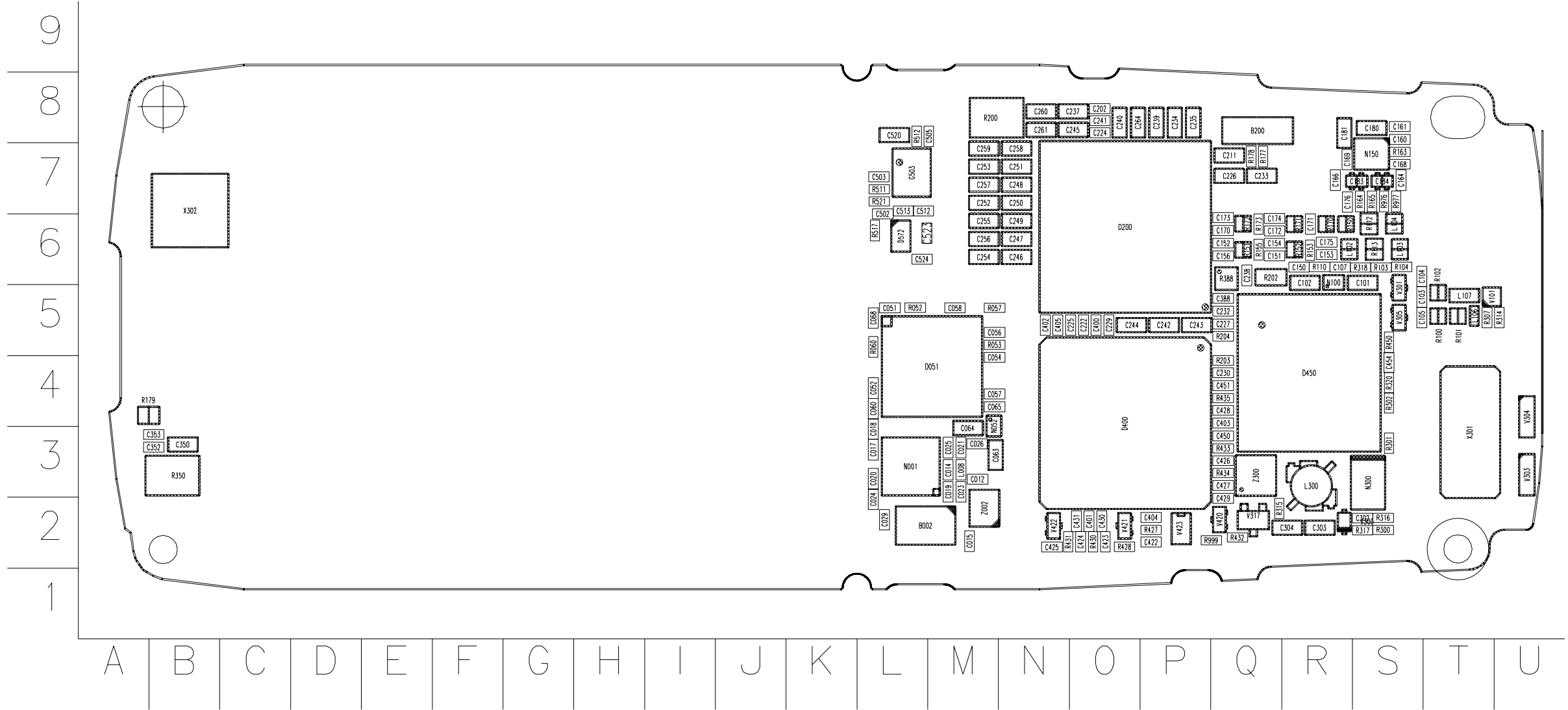

Component Layout — Bottom View

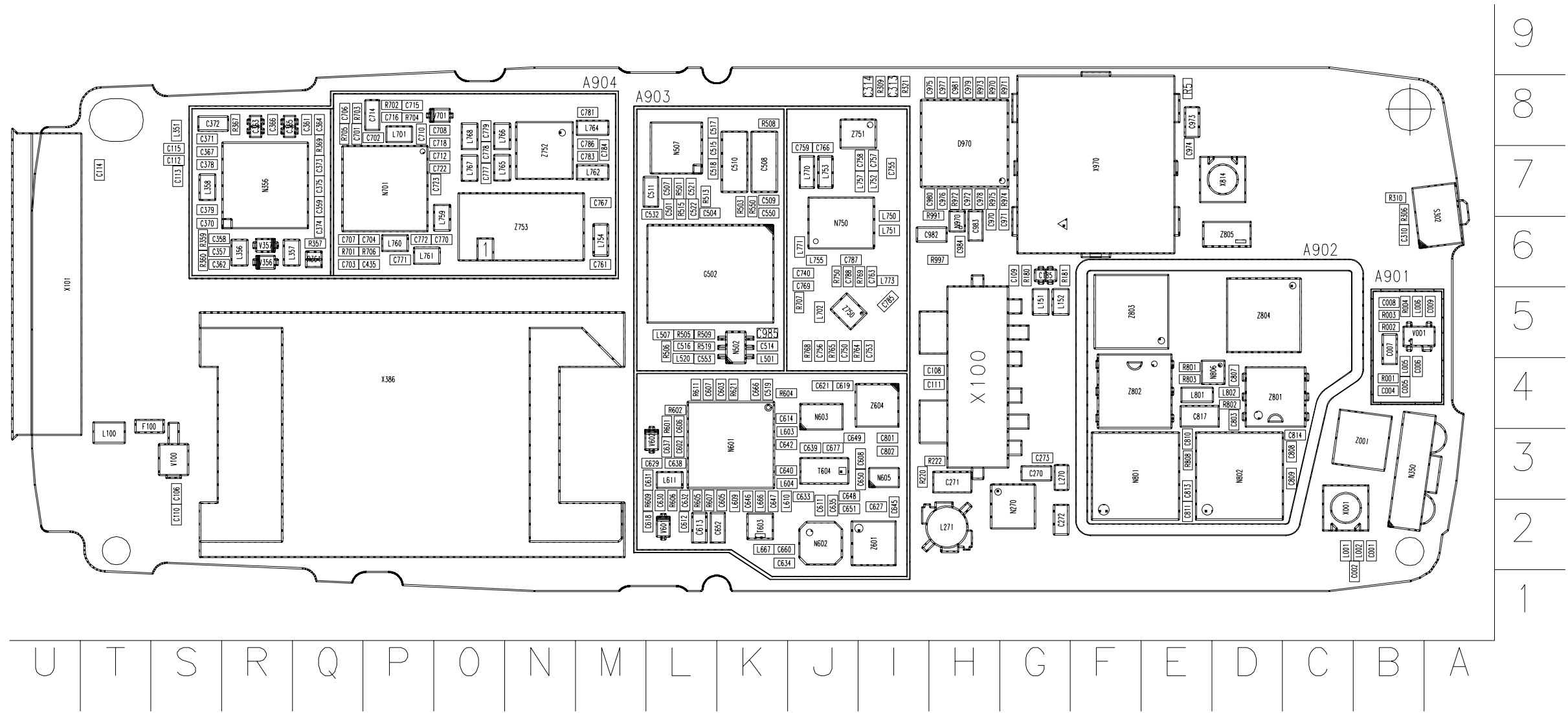

Component Values — Top

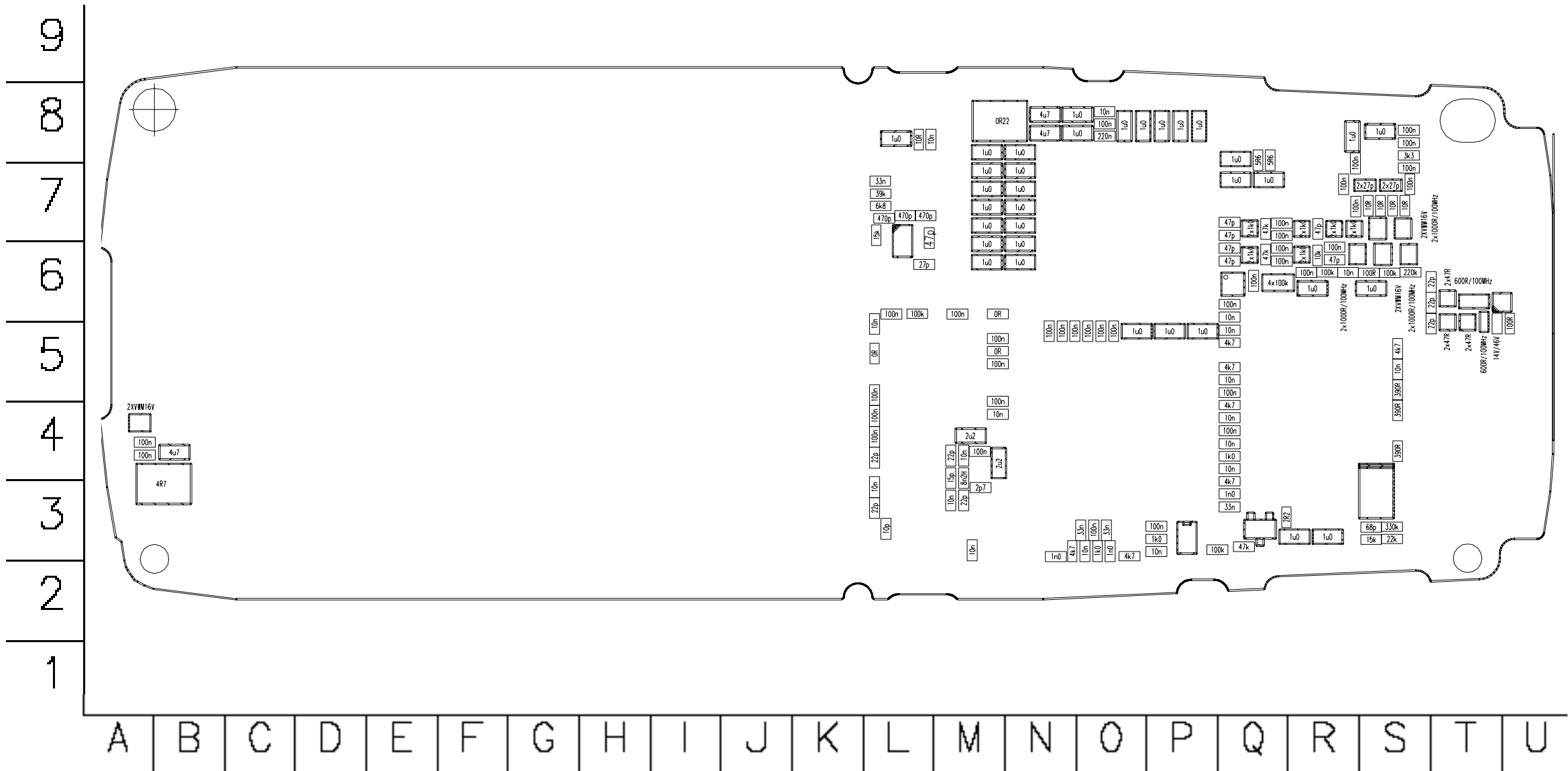

Component Values — Bottom

