

Appendix B: Schematic Diagrams

This appendix has circuit diagrams of the *W760S/W765S* notebook's PCB's. The following table indicates where to find the appropriate schematic diagram.

Diagram - Page	Diagram - Page	Diagram - Page
<i>System Block Diagram - Page B - 2</i>	<i>968 PCI, IDE, MuTIOL, SPI 1/4 - Page B - 15</i>	<i>LED, PC Beep, TP, FP - Page B - 28</i>
<i>Penryn (Socket-P) 1/2 - Page B - 3</i>	<i>968 PCIE, LAN, GPIO 2/4 - Page B - 16</i>	<i>System/Ext-VGA Power - Page B - 29</i>
<i>Penryn (Socket-P) 2/2 - Page B - 4</i>	<i>968 USB SATA 3/4 - Page B - 17</i>	<i>AC-IN, Charger - Page B - 30</i>
<i>SiSM672 Host, PCIE 1/5 - Page B - 5</i>	<i>968 PWR, GND 4/4 - Page B - 18</i>	<i>VCORE - Page B - 31</i>
<i>SiSM672 DRAM 2/5 - Page B - 6</i>	<i>Clock Generator & Clock Buffer - Page B - 19</i>	<i>VDD3, VDD5) - Page B - 32</i>
<i>SiSM672 MuTIOL VGA 3/5 - Page B - 7</i>	<i>PHY Realtek 8201CL - Page B - 20</i>	<i>1.05VS, 1.2V, 1.5V - Page B - 33</i>
<i>SiSM672 PWR 4/5 - Page B - 8</i>	<i>KBC ITE8512E - Page B - 21</i>	<i>1.8V, 0.9VS - Page B - 34</i>
<i>SiSM672 GND 5/5 - Page B - 9</i>	<i>JMB385, Card Reader - Page B - 22</i>	<i>Click BD, Finger BD for M76 - Page B - 35</i>
<i>DDRII SO-DIMM - 1 - Page B - 10</i>	<i>Audio Codec ALC662 - Page B - 23</i>	<i>Multi Function Board - Page B - 36</i>
<i>DDRII SO-DIMM - 2 - Page B - 11</i>	<i>Audio AMP - Page B - 24</i>	<i>Audio Board - Page B - 37</i>
<i>SiS307ELV - Page B - 12</i>	<i>SATA HDD, PWR, LID - Page B - 25</i>	<i>Power Switch Board for M74 - Page B - 38</i>
<i>Panel, CRT - Page B - 13</i>	<i>Multi I/O, ODD, 3G, Click BD for M74 - Page B - 26</i>	<i>External ODD Board for W76 - Page B - 39</i>
<i>Inverter, Bluetooth, Fan - Page B - 14</i>	<i>New Card, Mini PCIE, USB - Page B - 27</i>	

Table B - 1
**Schematic
Diagrams**



Version Note

The schematic diagrams in this chapter are based upon version 6-7P-M74SA-001. If your mainboard (or other boards) are a later version, please check with the Service Center for updated diagrams (if required).

System Block Diagram

Sheet 1 of 38
System Block
Diagram

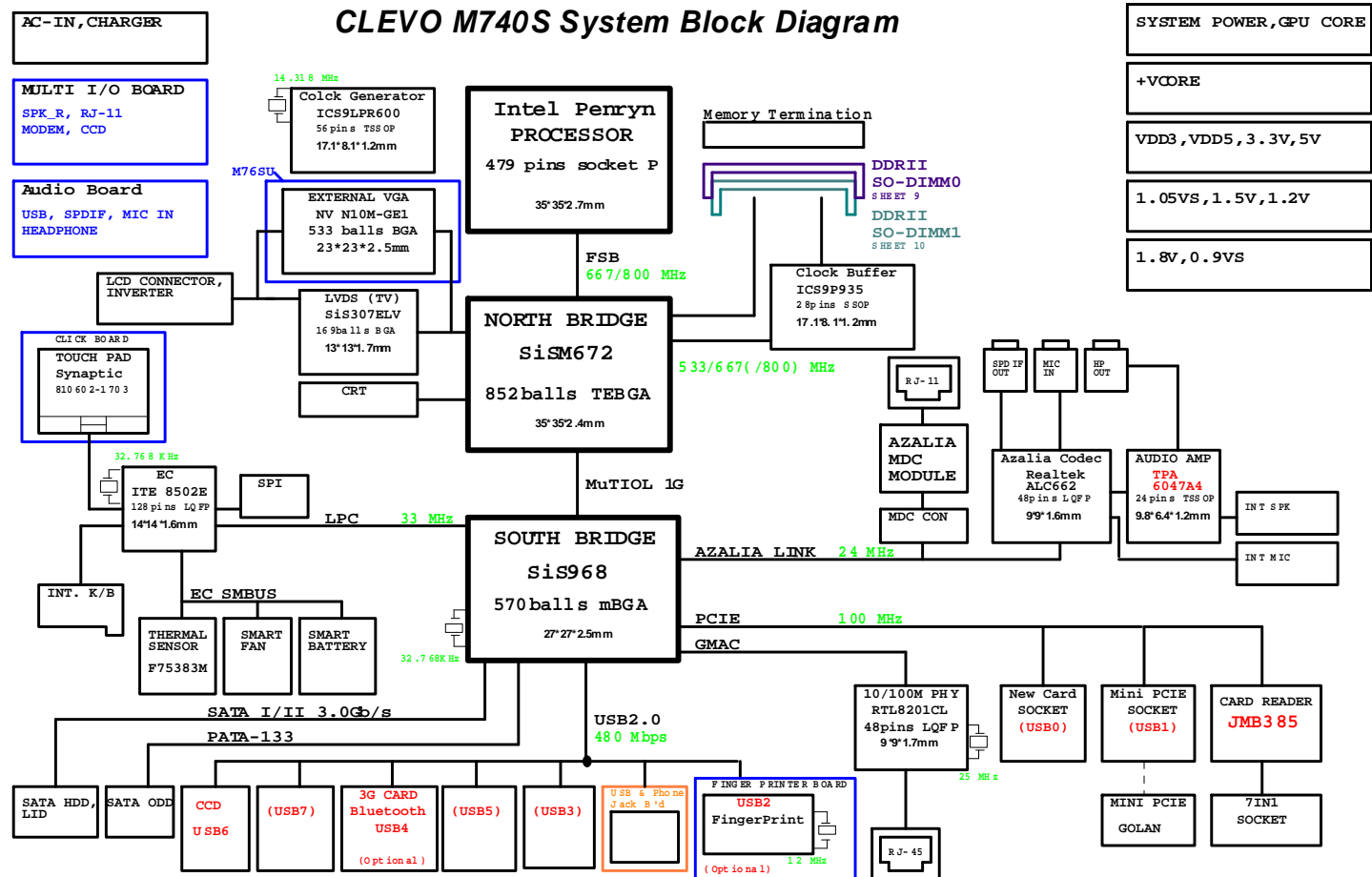

Penryn (Socket-P) 1/2

Sheet 2 of 38
Penryn (Socket-P)
1/2

B.Schematic Diagrams

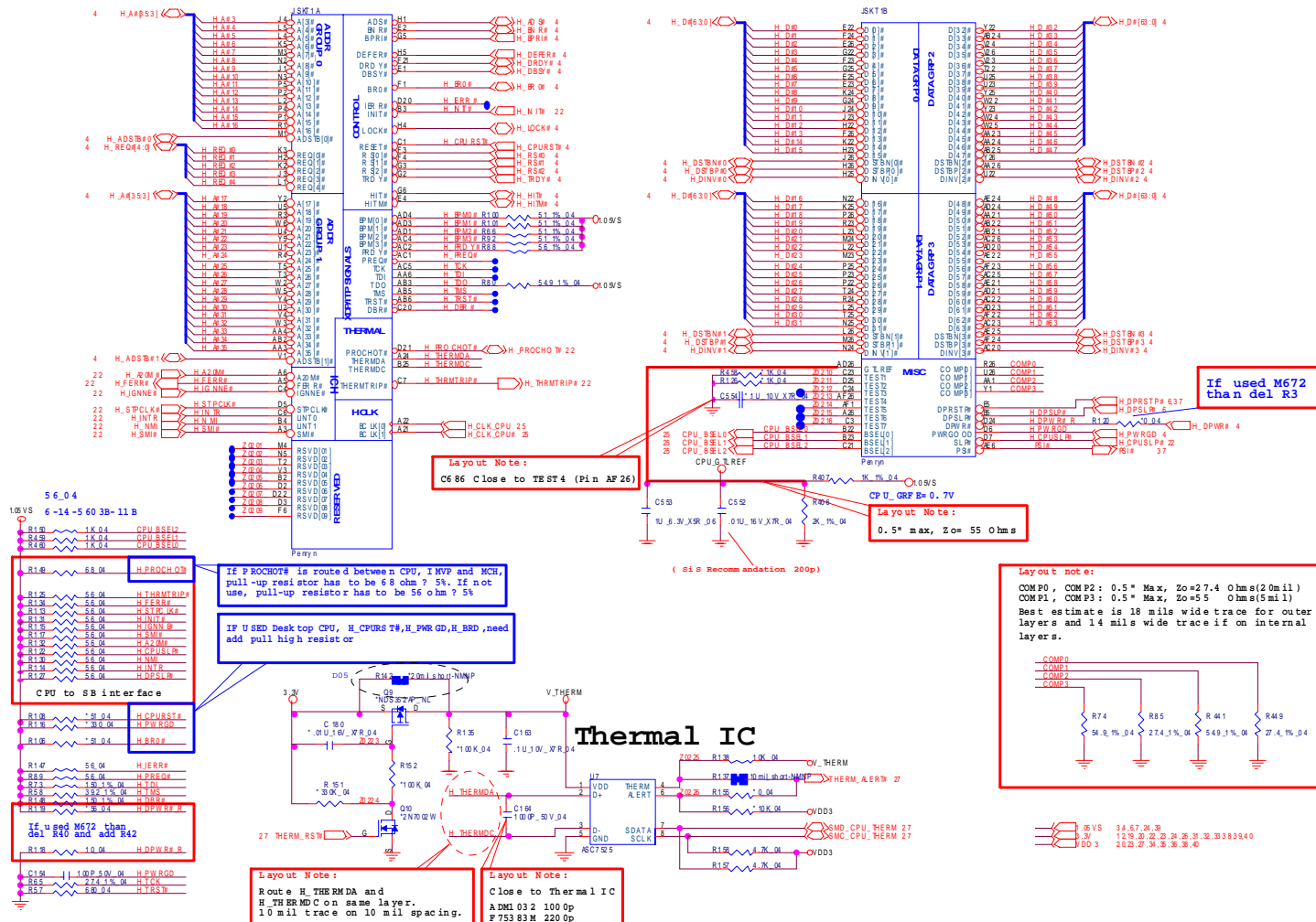

If used M672 than del R3

Layout Note :
0686 Close to TEST4 (Pin AF26)

Layout Note :
CPU_GRP = 0.7V
0.5" max, Zo = 55 Ohms

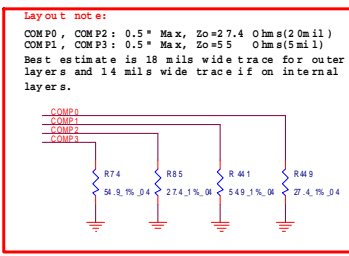

Layout note:
COM0, COM2 : 0.5" Max, Zo = 27.4 Ohms (20mil)
COM1, COM3 : 0.5" Max, Zo = 55 Ohms (5mil)
Best estimate is 18 mils wide trace for outer layers and 14 mils wide trace if on internal layers.

0.5V	34.67, 26.30
3.3V	12.90, 22.25, 24.26, 31.32, 33.83, 38.40
VDD3	20.23, 27.34, 35.36, 38.40

Layout Note :
Route H_THERMDA and H_THERMDC on same layer.
1.0 mil trace on 10 mil spacing.

Layout Note :
Close to Thermal IC
ADM1032 1000p
P75383M 2200p

56.04
6-14-5603B-11B

R18	1K.04	CPU_BSEL2
R19	12.04	CPU_BSEL4
R20	12.04	CPU_BSEL5
R18	56.04	H_PROCHOT
R19	56.04	H_THERMTRIP
R20	56.04	H_FERR0
R21	56.04	H_FERR1
R22	56.04	H_FERR2
R23	56.04	H_FERR3
R24	56.04	H_FERR4
R25	56.04	H_FERR5
R26	56.04	H_FERR6
R27	56.04	H_FERR7
R28	56.04	H_FERR8
R29	56.04	H_FERR9
R30	56.04	H_FERR10
R31	56.04	H_FERR11
R32	56.04	H_FERR12
R33	56.04	H_FERR13
R34	56.04	H_FERR14
R35	56.04	H_FERR15
R36	56.04	H_FERR16
R37	56.04	H_FERR17
R38	56.04	H_FERR18
R39	56.04	H_FERR19
R40	56.04	H_FERR20
R41	56.04	H_FERR21
R42	56.04	H_FERR22
R43	56.04	H_FERR23
R44	56.04	H_FERR24
R45	56.04	H_FERR25
R46	56.04	H_FERR26
R47	56.04	H_FERR27
R48	56.04	H_FERR28
R49	56.04	H_FERR29
R50	56.04	H_FERR30
R51	56.04	H_FERR31
R52	56.04	H_FERR32
R53	56.04	H_FERR33
R54	56.04	H_FERR34
R55	56.04	H_FERR35
R56	56.04	H_FERR36
R57	56.04	H_FERR37
R58	56.04	H_FERR38
R59	56.04	H_FERR39
R60	56.04	H_FERR40
R61	56.04	H_FERR41
R62	56.04	H_FERR42
R63	56.04	H_FERR43
R64	56.04	H_FERR44
R65	56.04	H_FERR45
R66	56.04	H_FERR46
R67	56.04	H_FERR47
R68	56.04	H_FERR48
R69	56.04	H_FERR49
R70	56.04	H_FERR50
R71	56.04	H_FERR51
R72	56.04	H_FERR52
R73	56.04	H_FERR53
R74	56.04	H_FERR54
R75	56.04	H_FERR55
R76	56.04	H_FERR56
R77	56.04	H_FERR57
R78	56.04	H_FERR58
R79	56.04	H_FERR59
R80	56.04	H_FERR60
R81	56.04	H_FERR61
R82	56.04	H_FERR62
R83	56.04	H_FERR63
R84	56.04	H_FERR64
R85	56.04	H_FERR65
R86	56.04	H_FERR66
R87	56.04	H_FERR67
R88	56.04	H_FERR68
R89	56.04	H_FERR69
R90	56.04	H_FERR70
R91	56.04	H_FERR71
R92	56.04	H_FERR72
R93	56.04	H_FERR73
R94	56.04	H_FERR74
R95	56.04	H_FERR75
R96	56.04	H_FERR76
R97	56.04	H_FERR77
R98	56.04	H_FERR78
R99	56.04	H_FERR79
R100	56.04	H_FERR80
R101	56.04	H_FERR81
R102	56.04	H_FERR82
R103	56.04	H_FERR83
R104	56.04	H_FERR84
R105	56.04	H_FERR85
R106	56.04	H_FERR86
R107	56.04	H_FERR87
R108	56.04	H_FERR88
R109	56.04	H_FERR89
R110	56.04	H_FERR90
R111	56.04	H_FERR91
R112	56.04	H_FERR92
R113	56.04	H_FERR93
R114	56.04	H_FERR94
R115	56.04	H_FERR95
R116	56.04	H_FERR96
R117	56.04	H_FERR97
R118	56.04	H_FERR98
R119	56.04	H_FERR99
R120	56.04	H_FERR100

Penryn (Socket-P) 2/2

Sheet 3 of 38
Penryn (Socket-P)
2/2

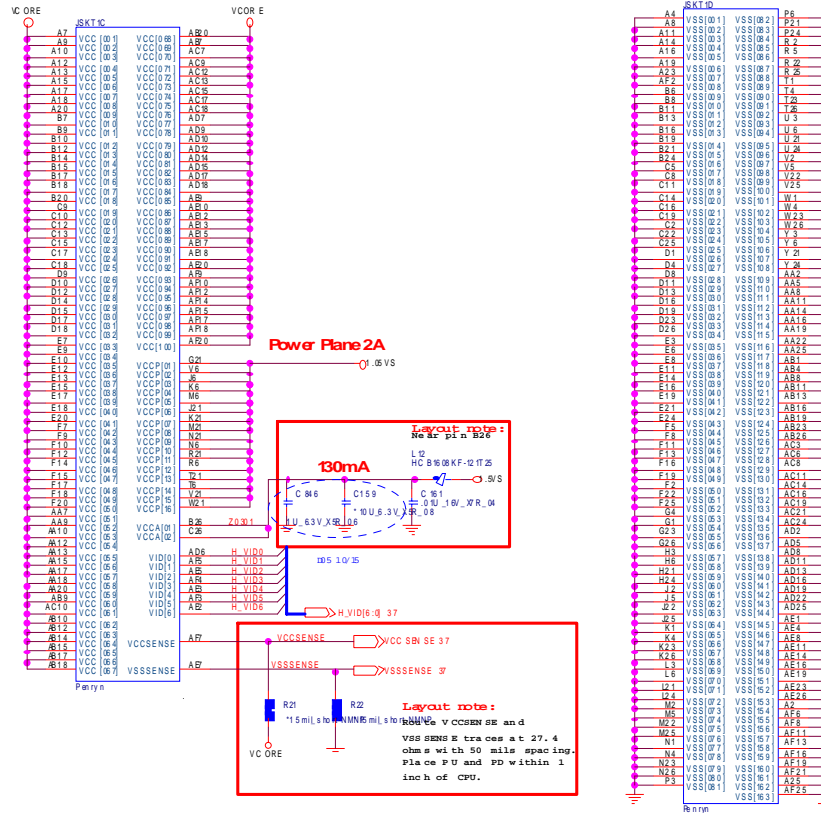

Check cap for santa rosa platform

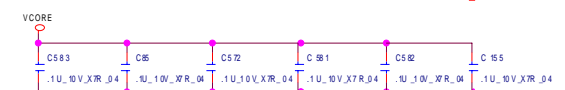
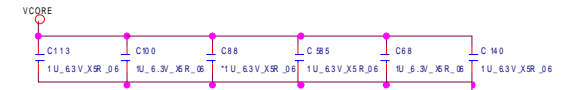
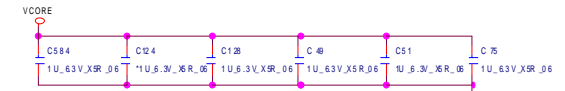
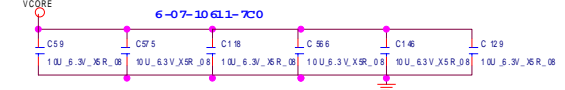
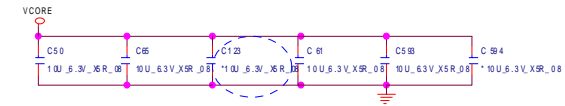
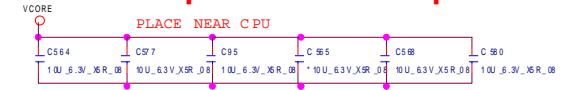

PLACE NEAR CPU

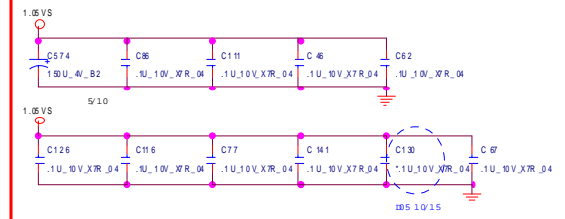

SiSM672 Host, PCIE 1/5

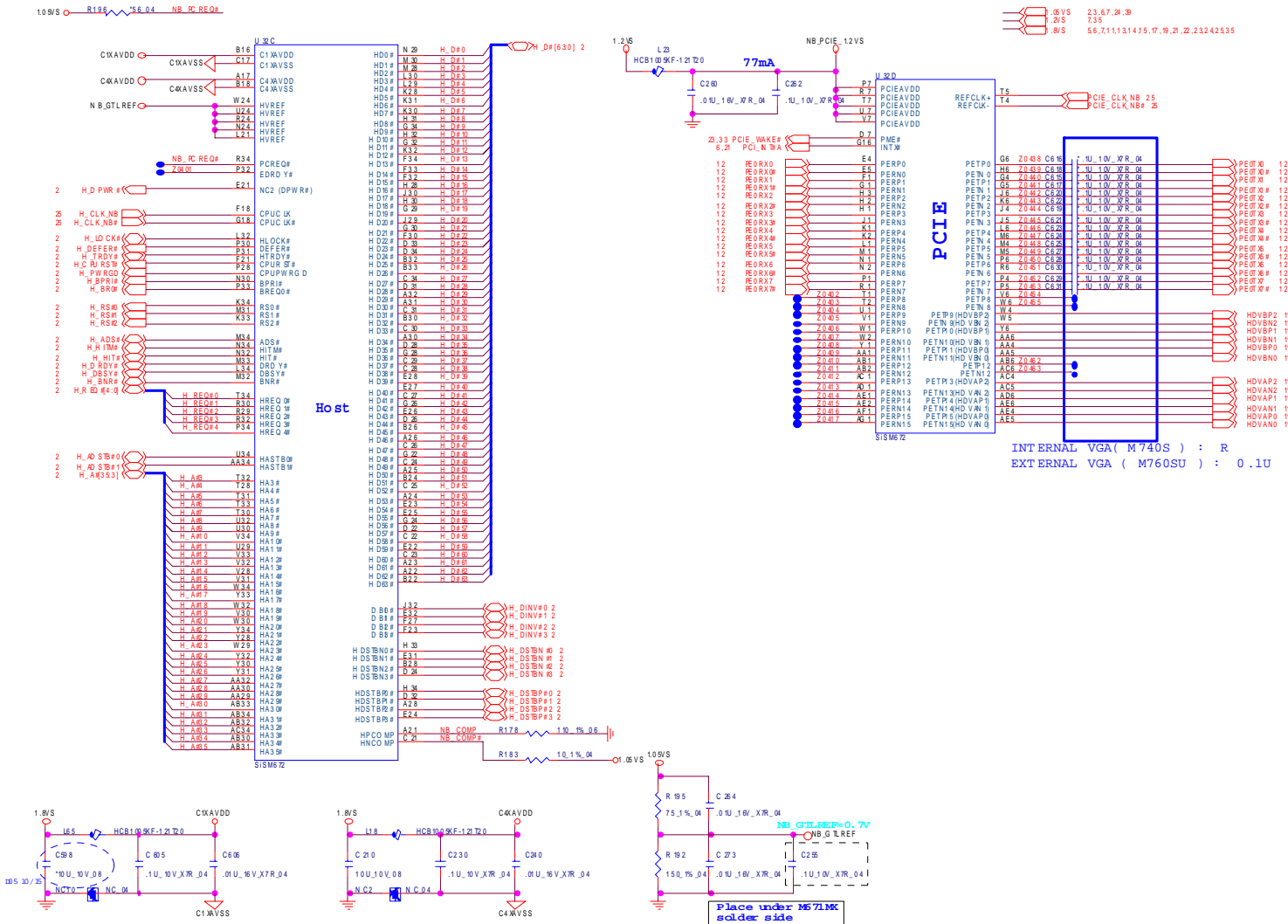

Sheet 4 of 38
SiSM672 Host,
PCIE 1/5

B. Schematic Diagrams

SiSM672 DRAM 2/5

Sheet 5 of 38
SiSM672 DRAM 2/5

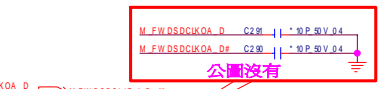
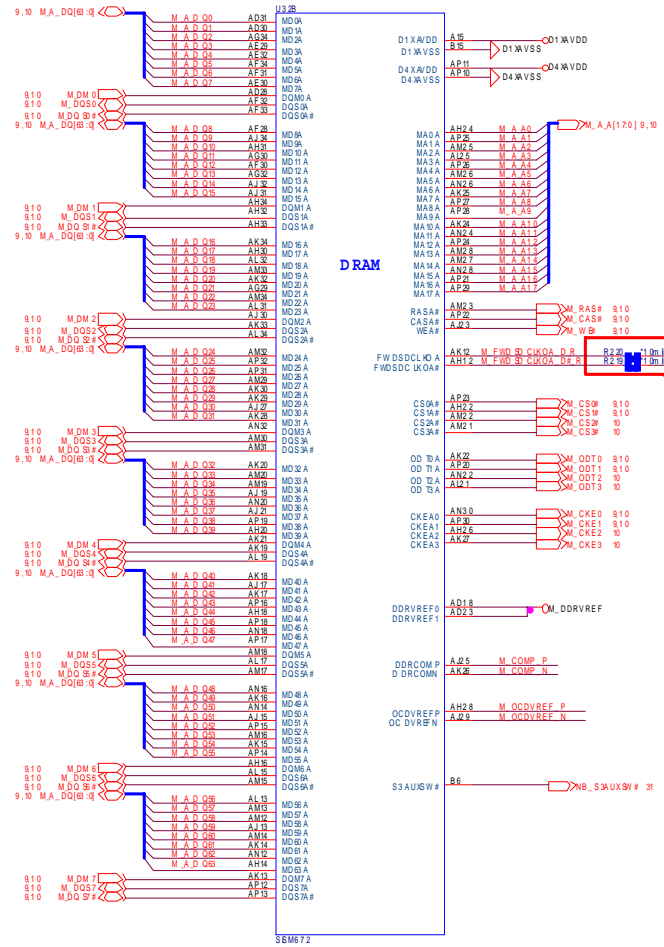
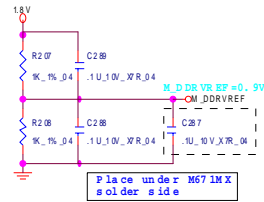
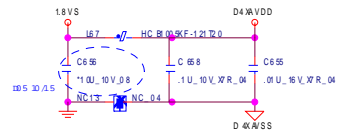
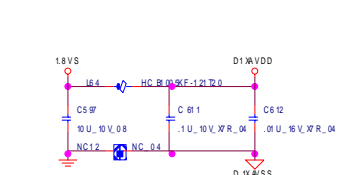

Place close to M67 1Mx

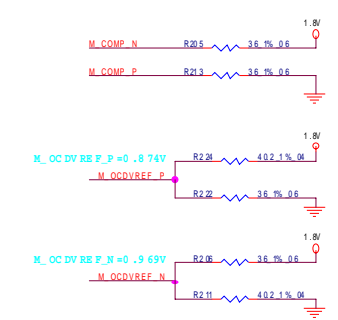

1.8V 7.910222324353840
1.8V 4.67111314151719202122242535

SiSM672 MuTIOL VGA 3/5

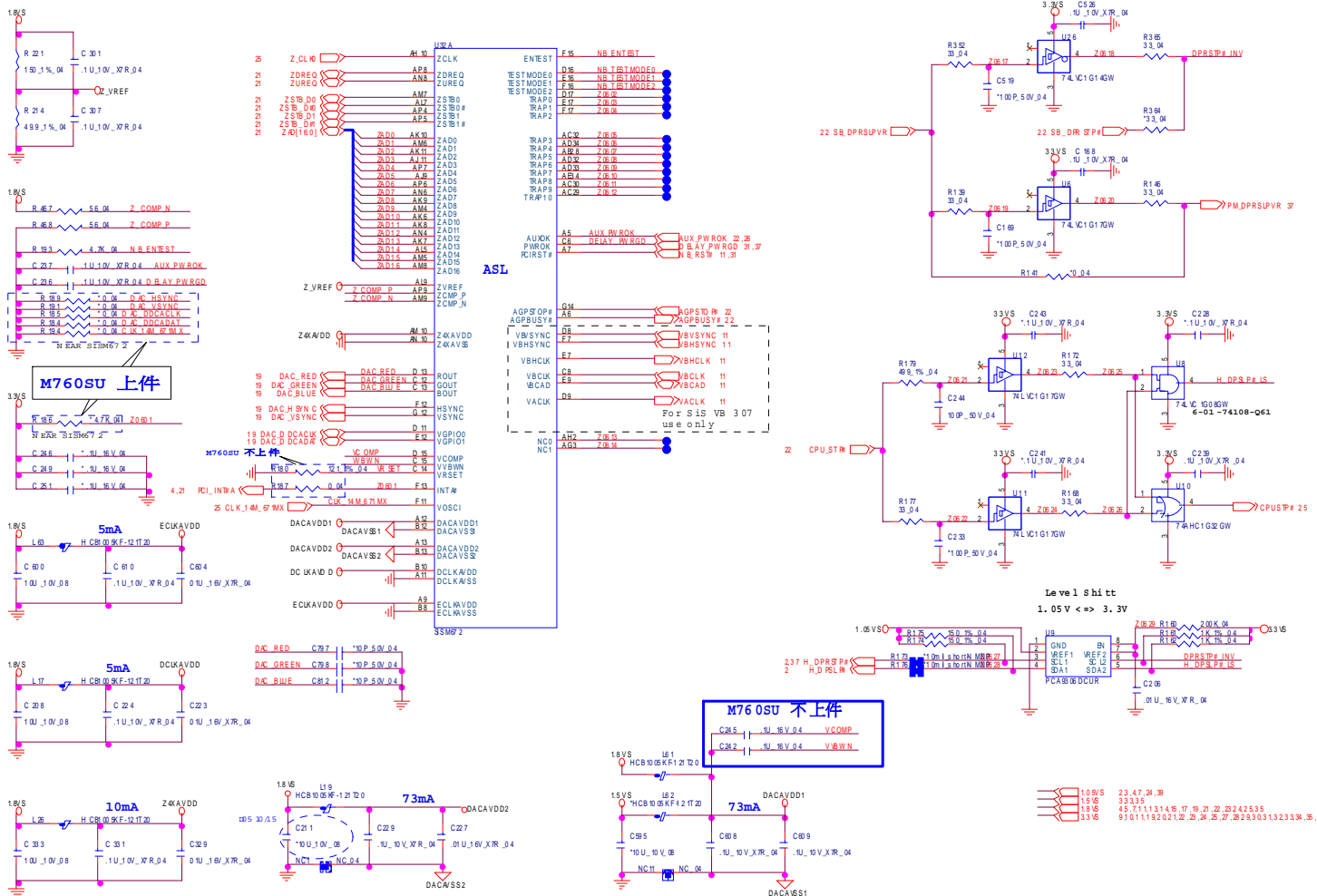

Sheet 6 of 38
SiSM672 MuTIOL
VGA 3/5

B. Schematic Diagrams

Schematic Diagrams

SiSM672 PWR 4/5

Sheet 7 of 38
SiSM672 PWR 4/5

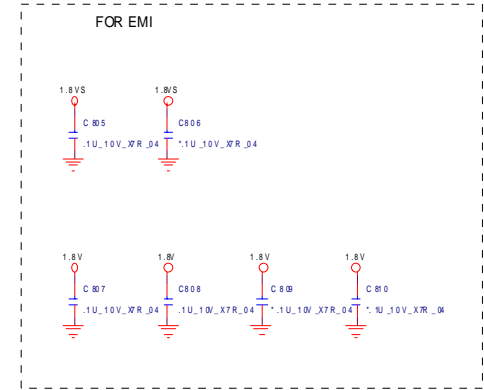
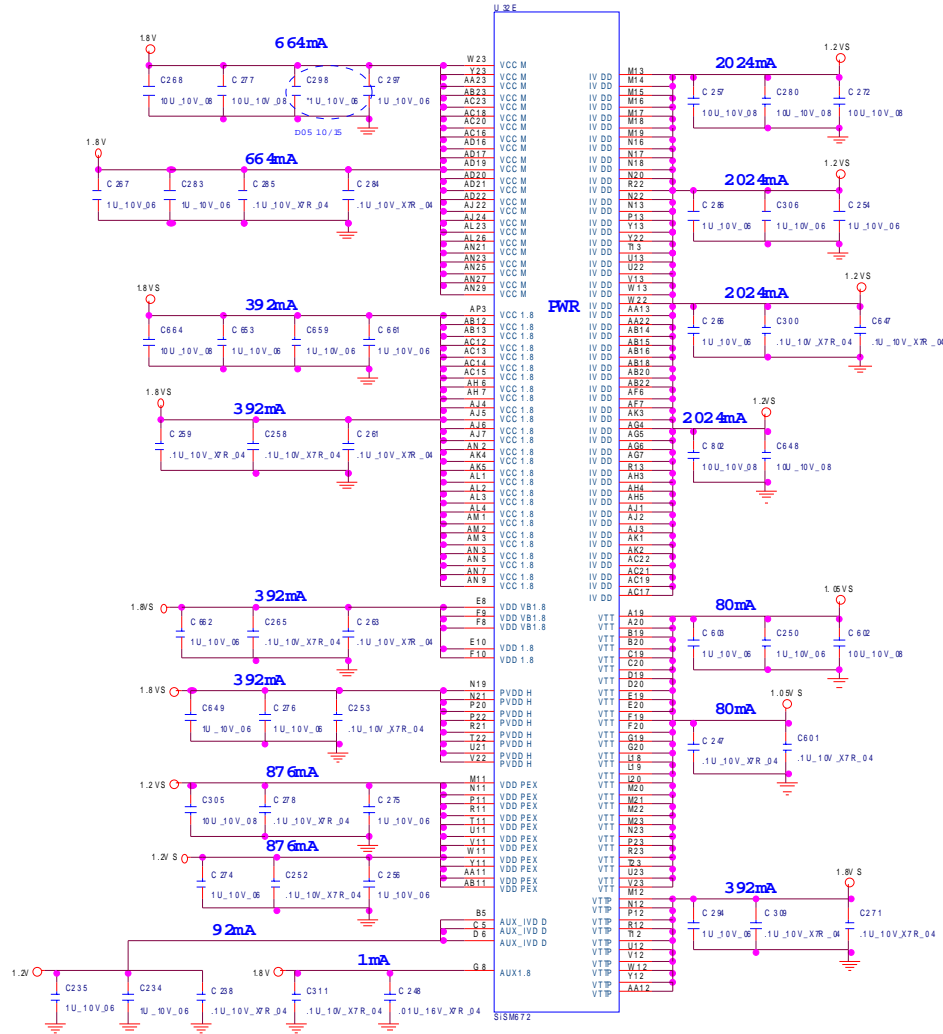

1.0V S	2,3,46,24,39
1.2V	35,39
1.2V S	4,35
1.8V	5,9,10,22,25,24,35,39,40
1.8V S	4,5,6,11,13,14,15,17,19,21,22,23,24,25,35

SiSM672 GND 5/5

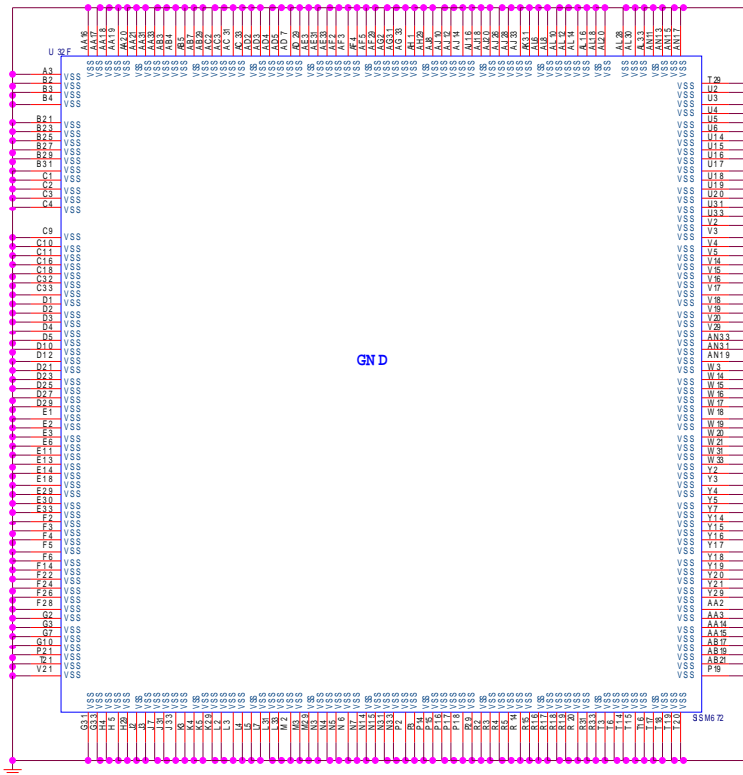

GND

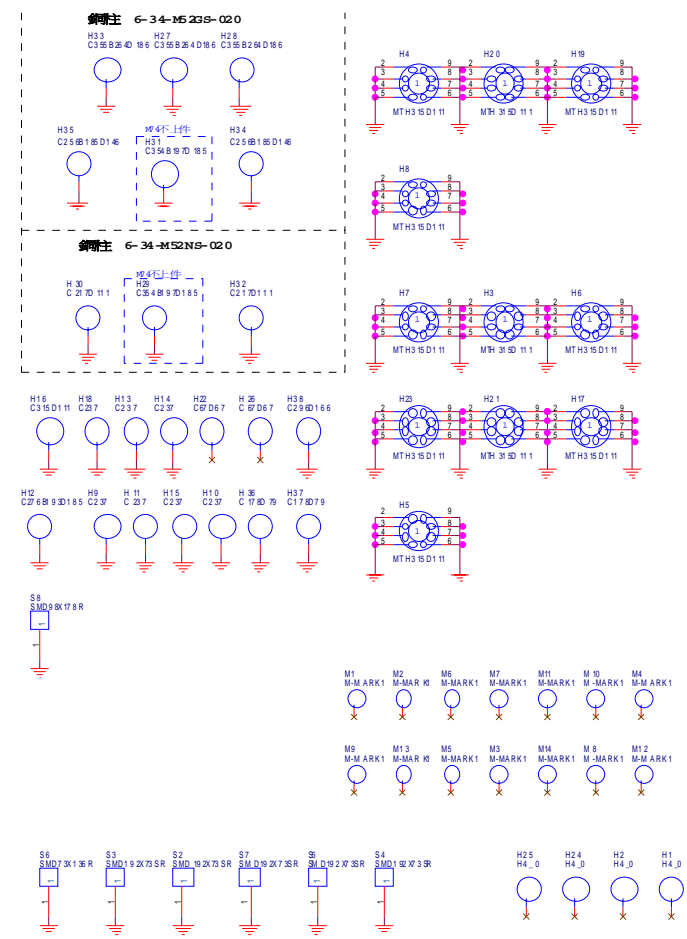

Sheet 8 of 38
SiSM672 GND 5/5

B. Schematic Diagrams

DDRII SO-DIMM - 1

SO-DIMM 1

Sheet 9 of 38
DDRII SO-DIMM - 1

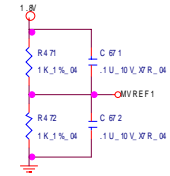
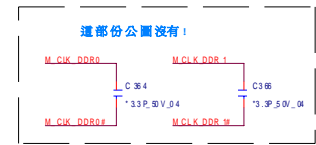
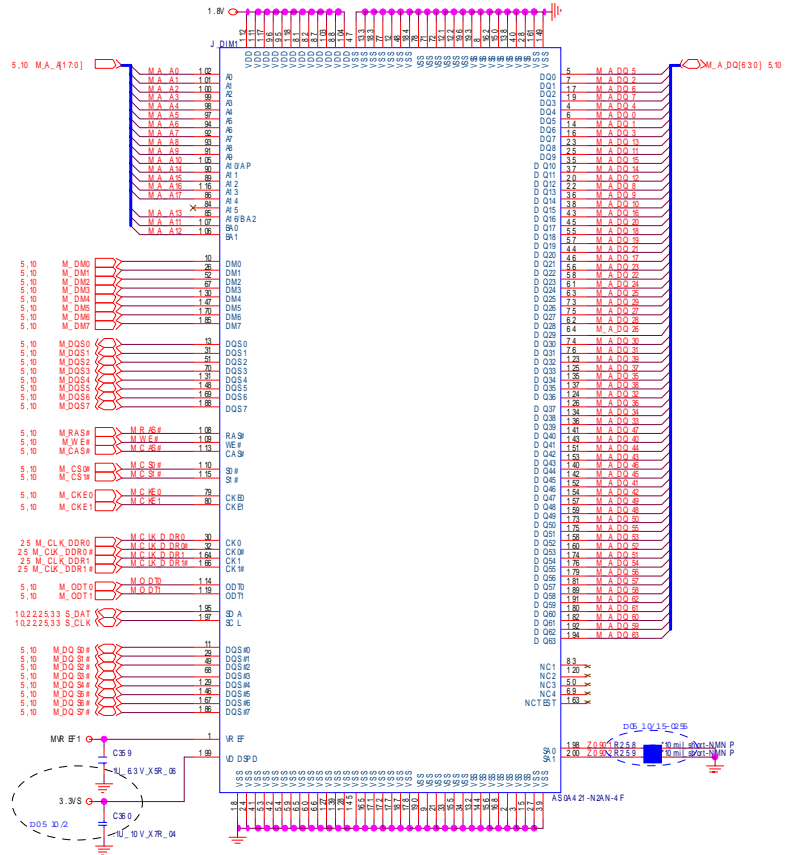

1.8V 5.7102223243539_40
3.3VS 6,10,11,19,20,21,22,23,24,25,27,28,29,30,31,32,33,34,35,37

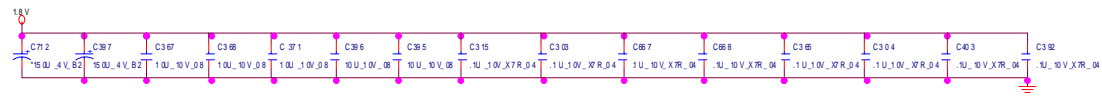

DDR2 SO-DIMM - 2

SO-DIMM 2

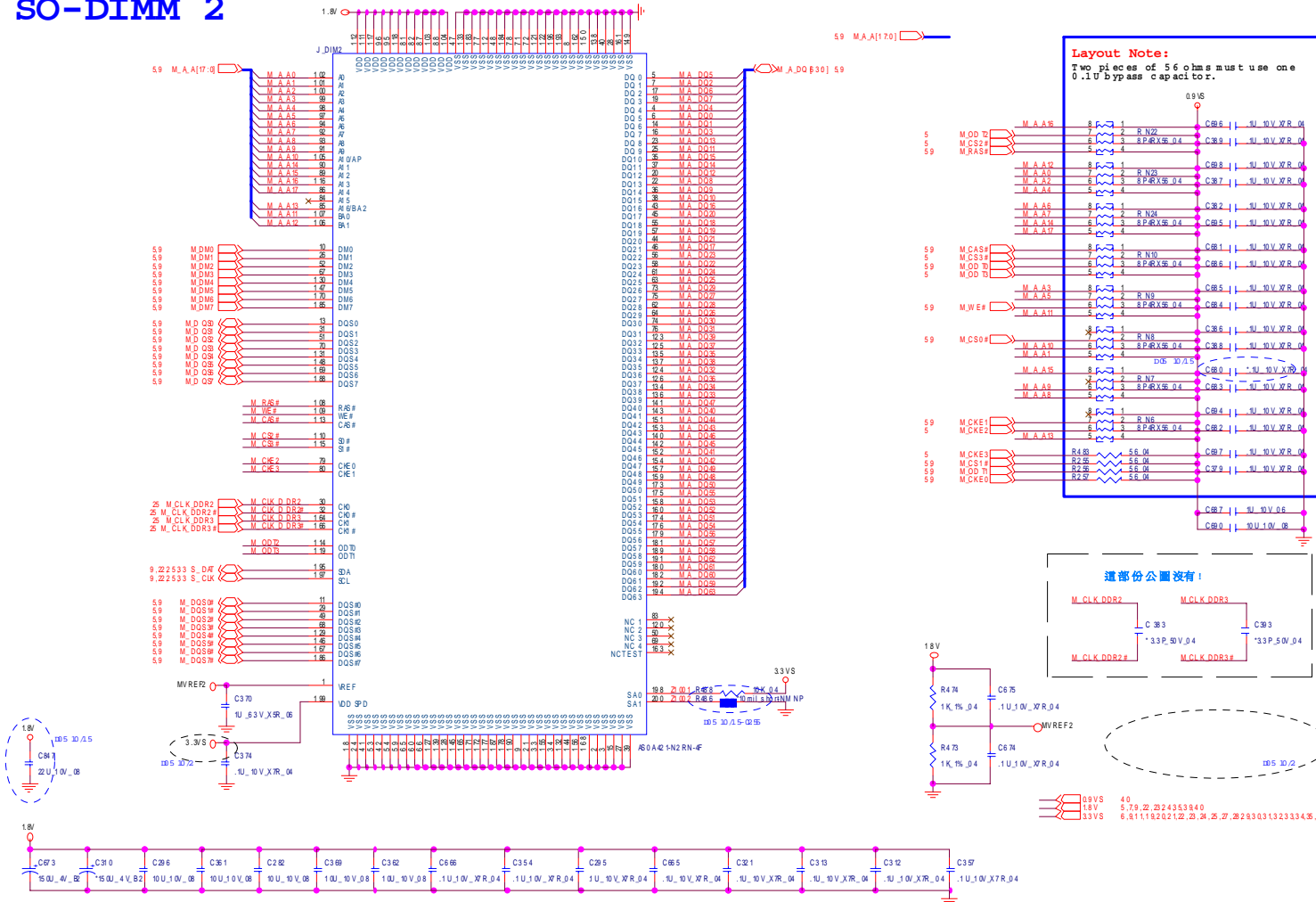

B.Schematic Diagrams

Sheet 10 of 38
DDR2 SO-DIMM - 2

SiS307ELV

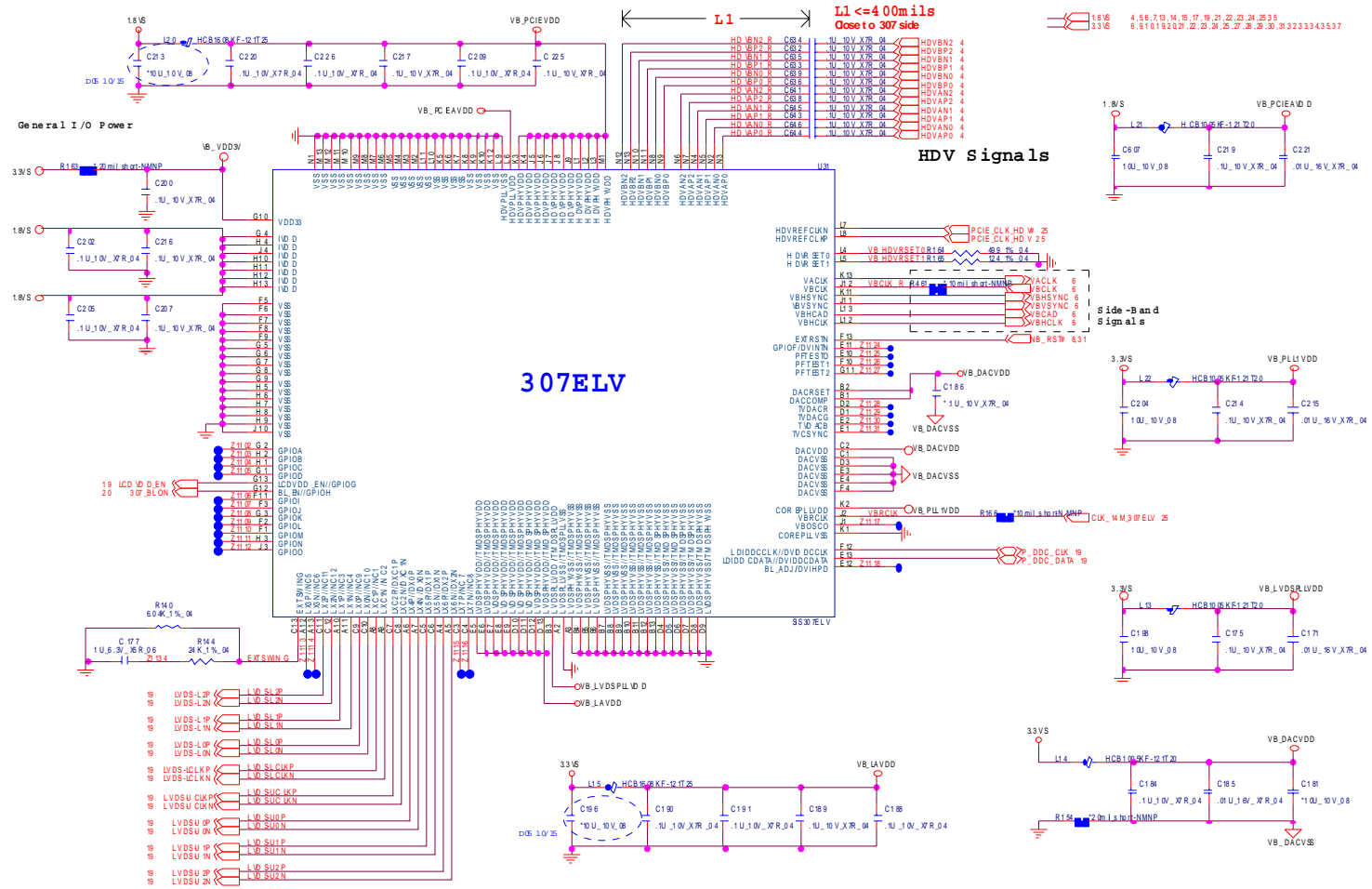

Panel, CRT

CRT

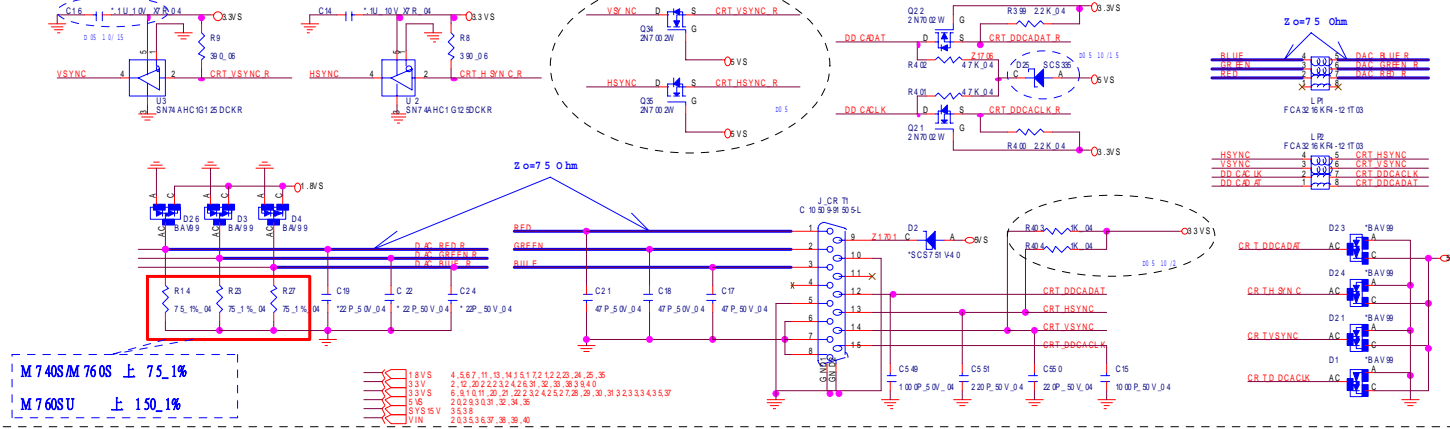

PANEL

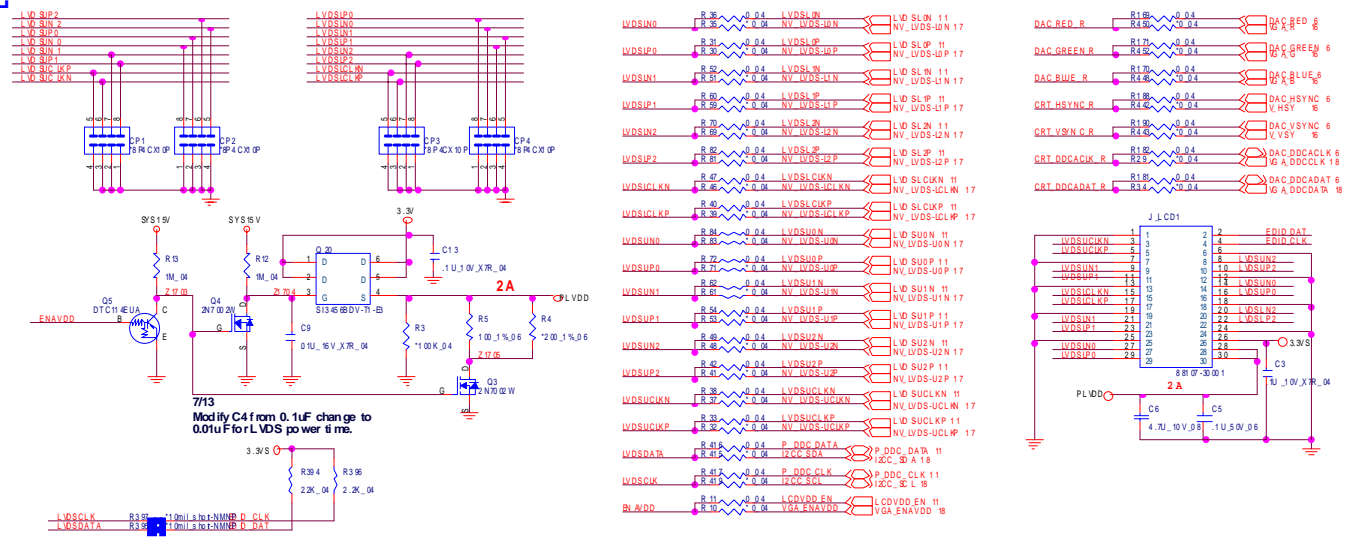

Sheet 12 of 38
Panel, CRT

B.Schematic Diagrams

968 PCIE, LAN, GPIO 2/4

Sheet 15 of 38
968 PCIE, LAN,
GPIO 2/4

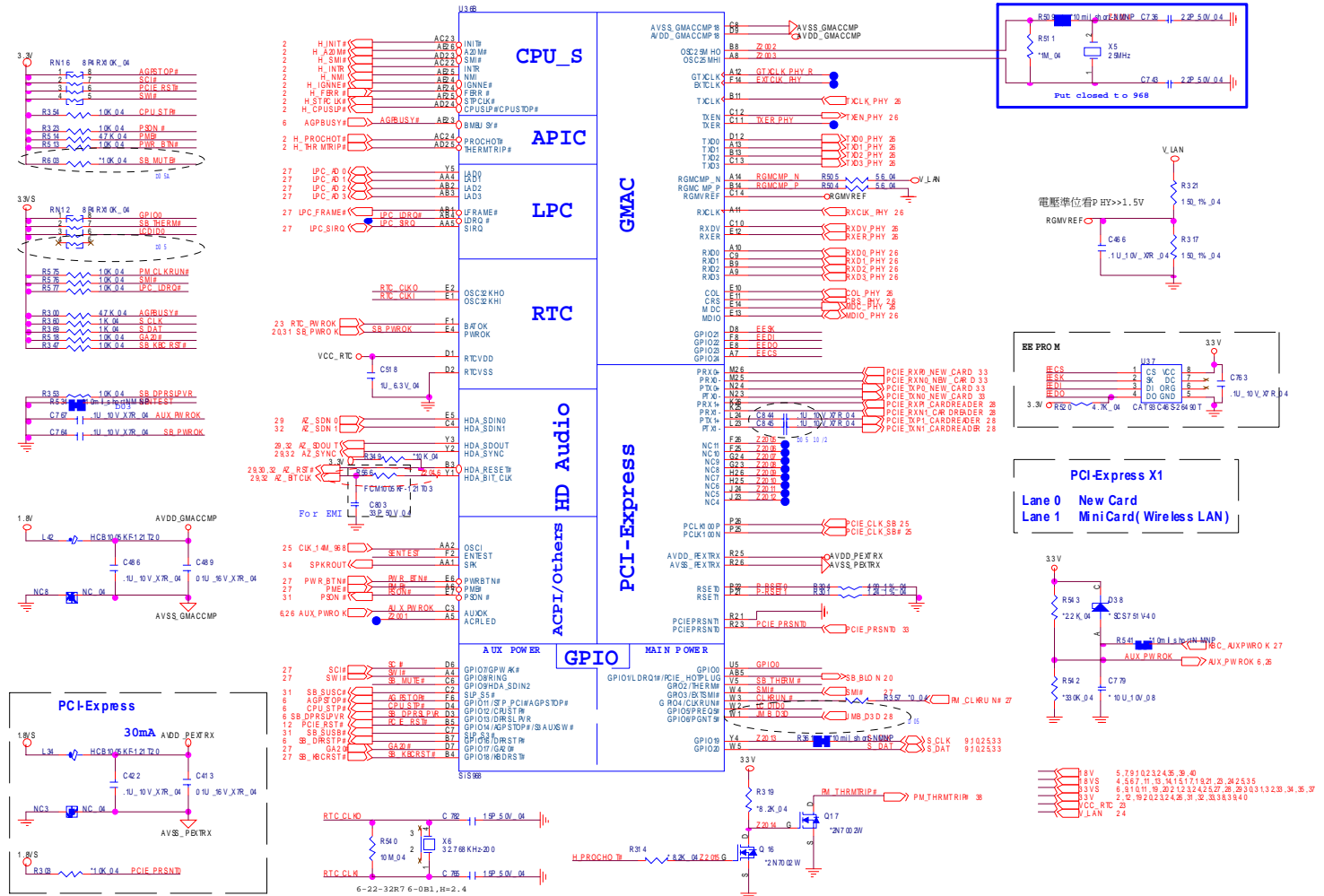

968 USB SATA 3/4

- USB 0: NEW CARD
- USB 1: MINI CARD
- USB 2: FINGER PRINTER
- USB 3: PORT0
- USB 4: BLUETOOTH OR 3G
- USB 5: PORT1
- USB 6: CCD
- USB 7: PORT2

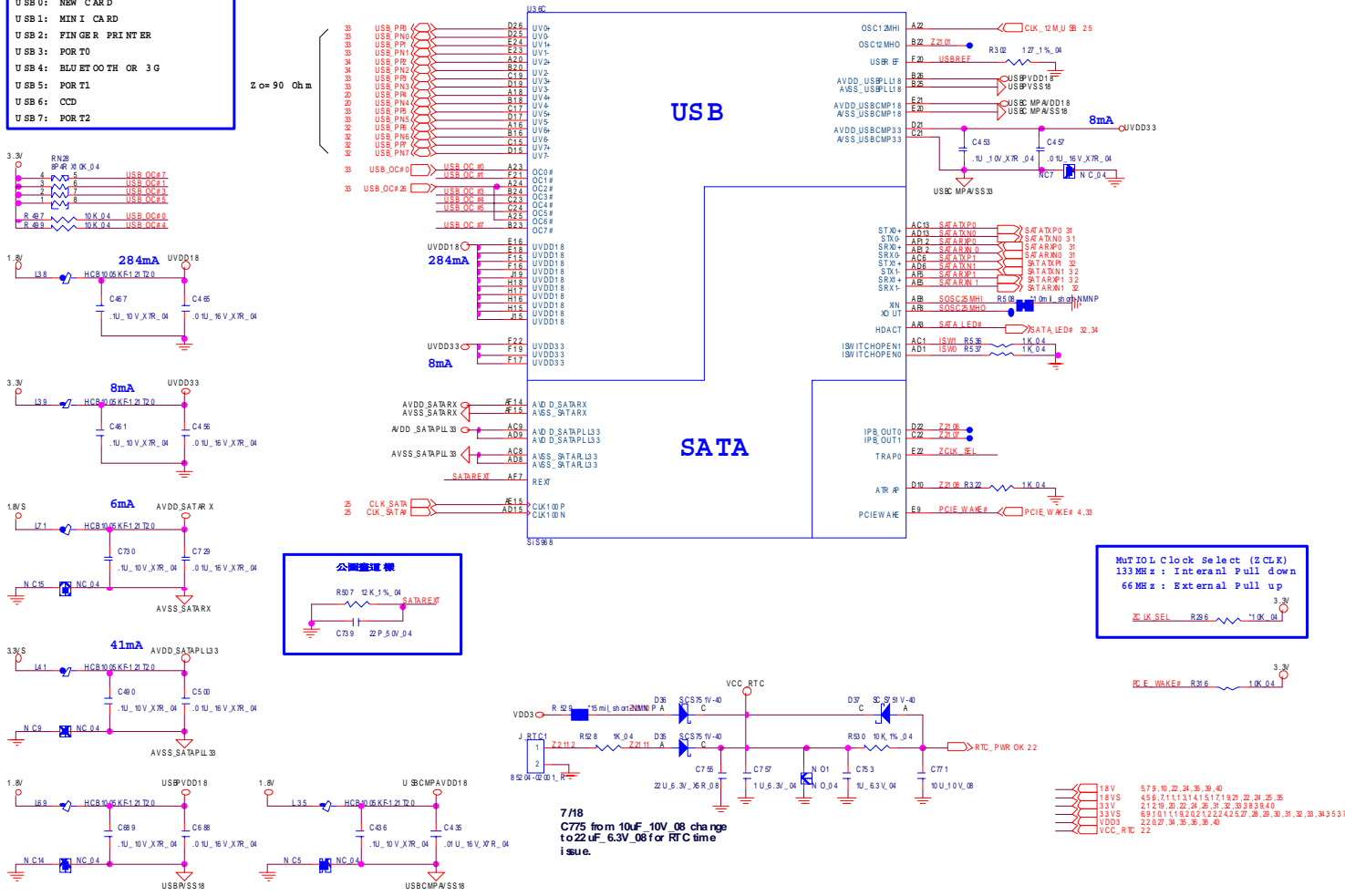

Z0 = 90 Ohm

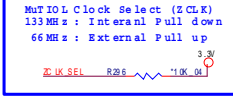
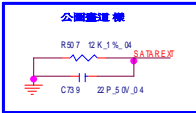

7/18
C775 from 10uF 10V_08 change to 22uF_6.3V_08 for RTC time issue.

- 1.8V 579, 10, 22, 31, 35, 38, 40
- 1.8VS 458, 711, 1131, 1415, 1719, 21, 24, 25, 35
- 3.3V 212, 19, 20, 22, 24, 26, 31, 32, 33, 38, 84, 0
- 3.3VS 891, 11, 150, 204, 222, 425, 7, 29, 30, 31, 32, 33, 34, 35, 37
- VDD3 22, 27, 34, 35, 38, 40
- VCC_RTC 22

Sheet 16 of 38
968 USB SATA 3/4

B. Schematic Diagrams

968 PWR, GND 4/4

Sheet 17 of 38
968 PWR, GND 4/4

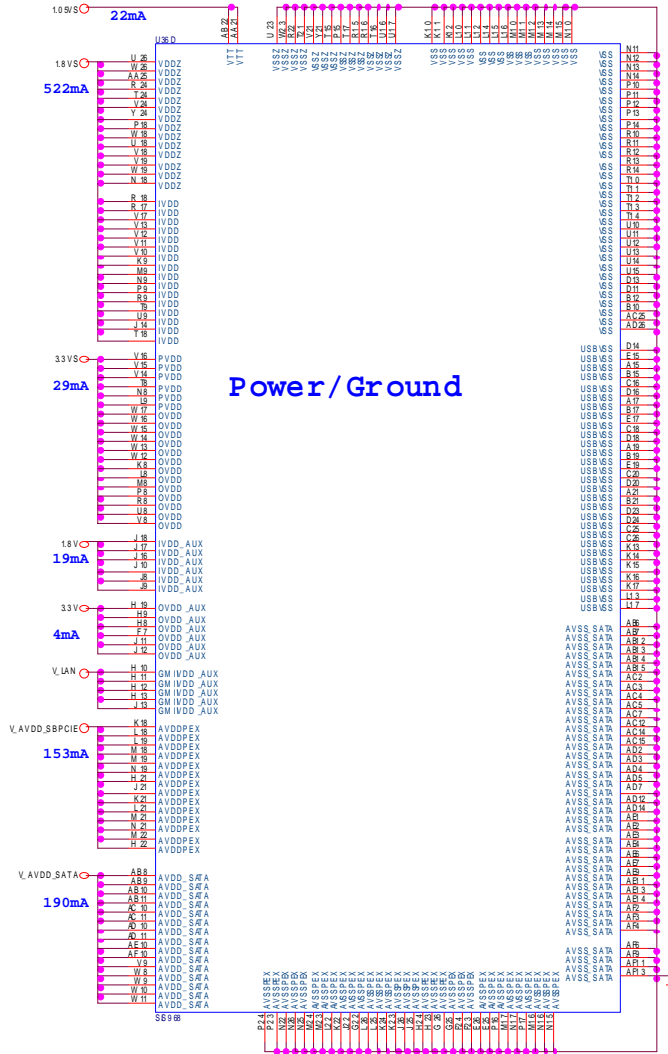

Power / Ground

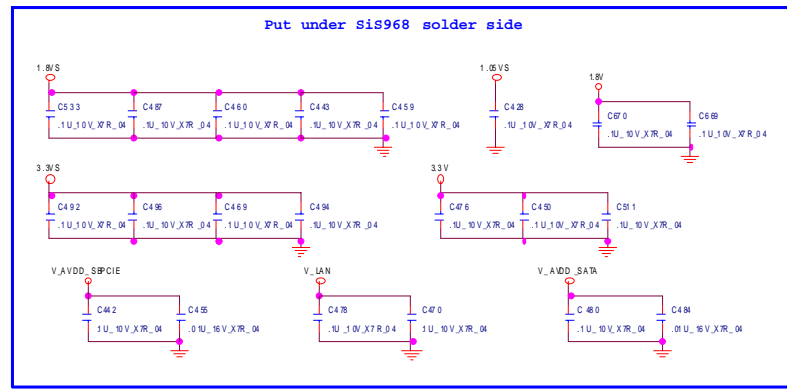
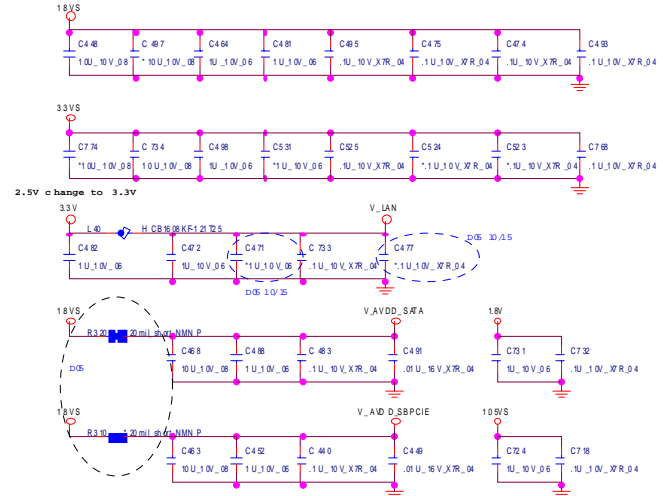

1.8V/S	2,348,739
1.8V	5,791,022,233,538,840
3V/S	4,667,11,33,34,35,37,39,21,22,23,25,35
3.3V	2,12,19,20,22,23,26,31,32,33,33,38,340
3.3V/S	6,11,11,19,20,21,22,23,25,27,28,29,30,31,32,33,34,35,37
V.LAN	22

Clock Generator & Clock Buffer

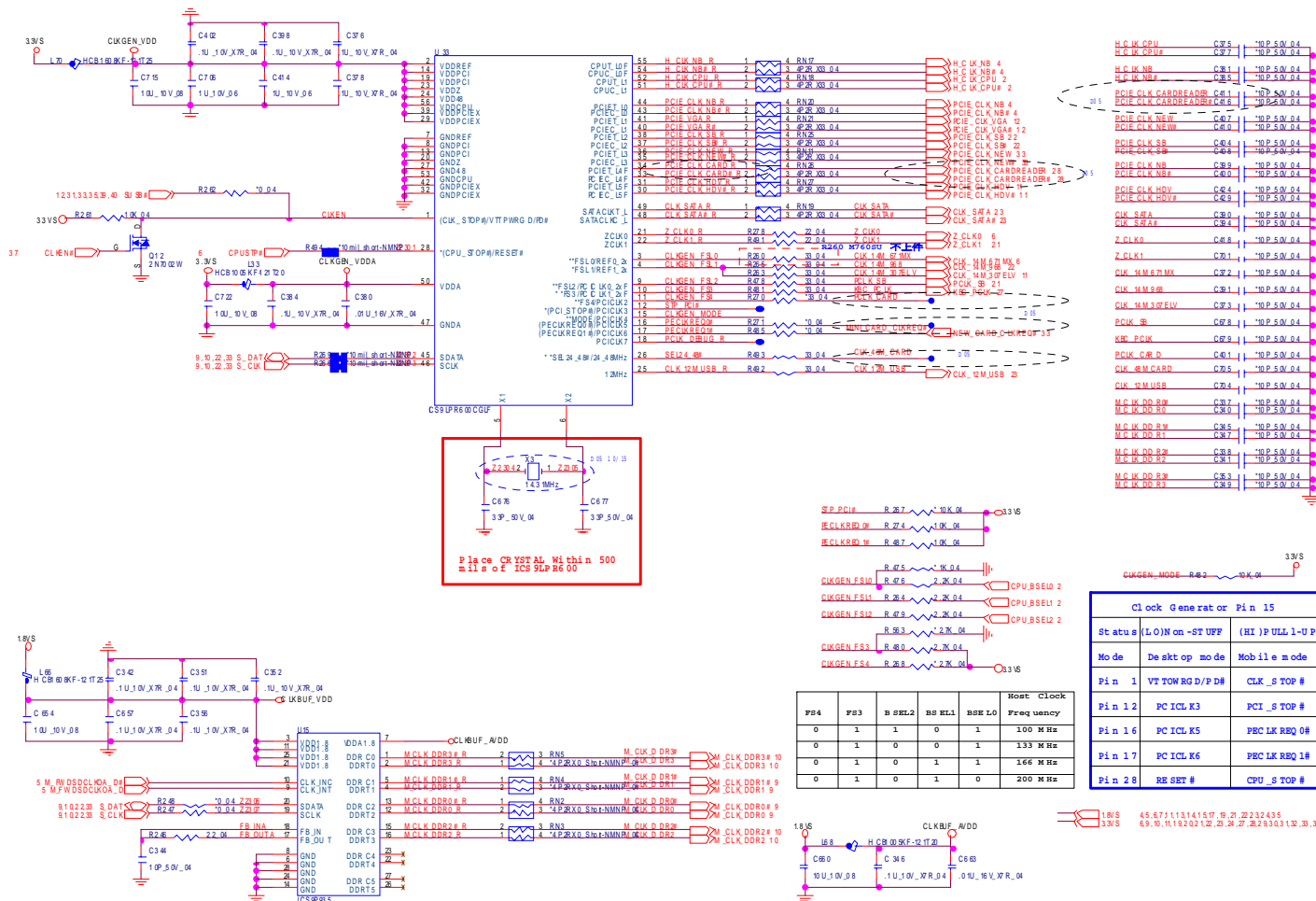

Sheet 18 of 38
Clock Generator &
Clock Buffer

Schematic Diagrams

PHY Realtek 8201CL

Sheet 19 of 38
PHY Realtek
8201CL

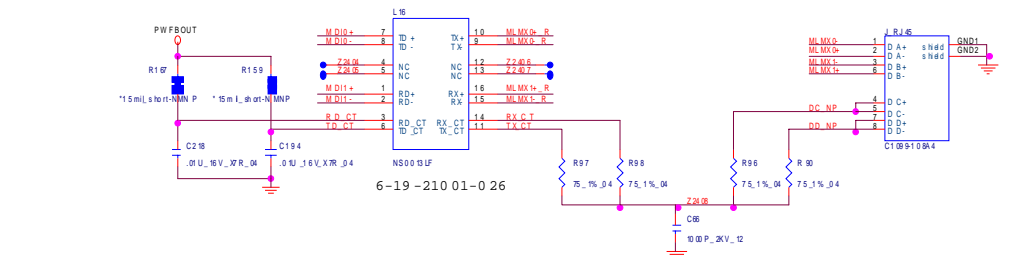
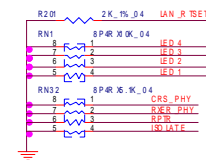
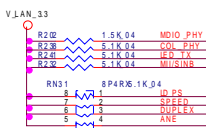
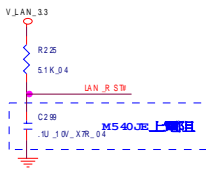
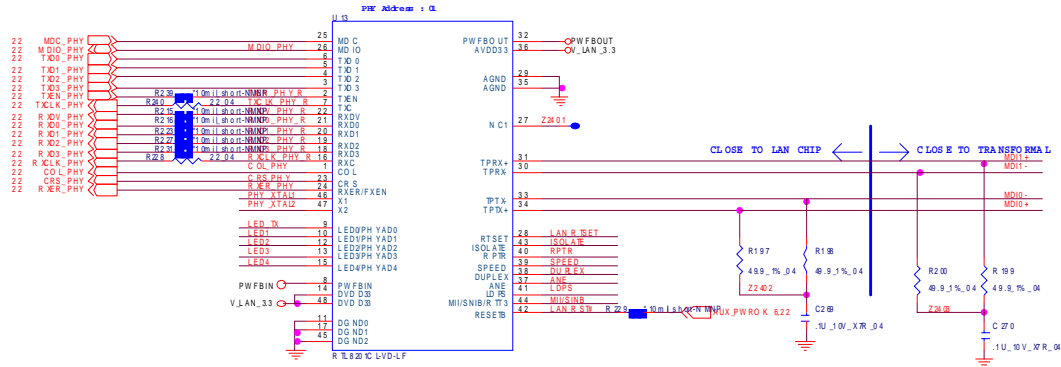
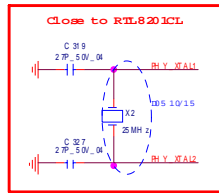

KBC ITE8512E

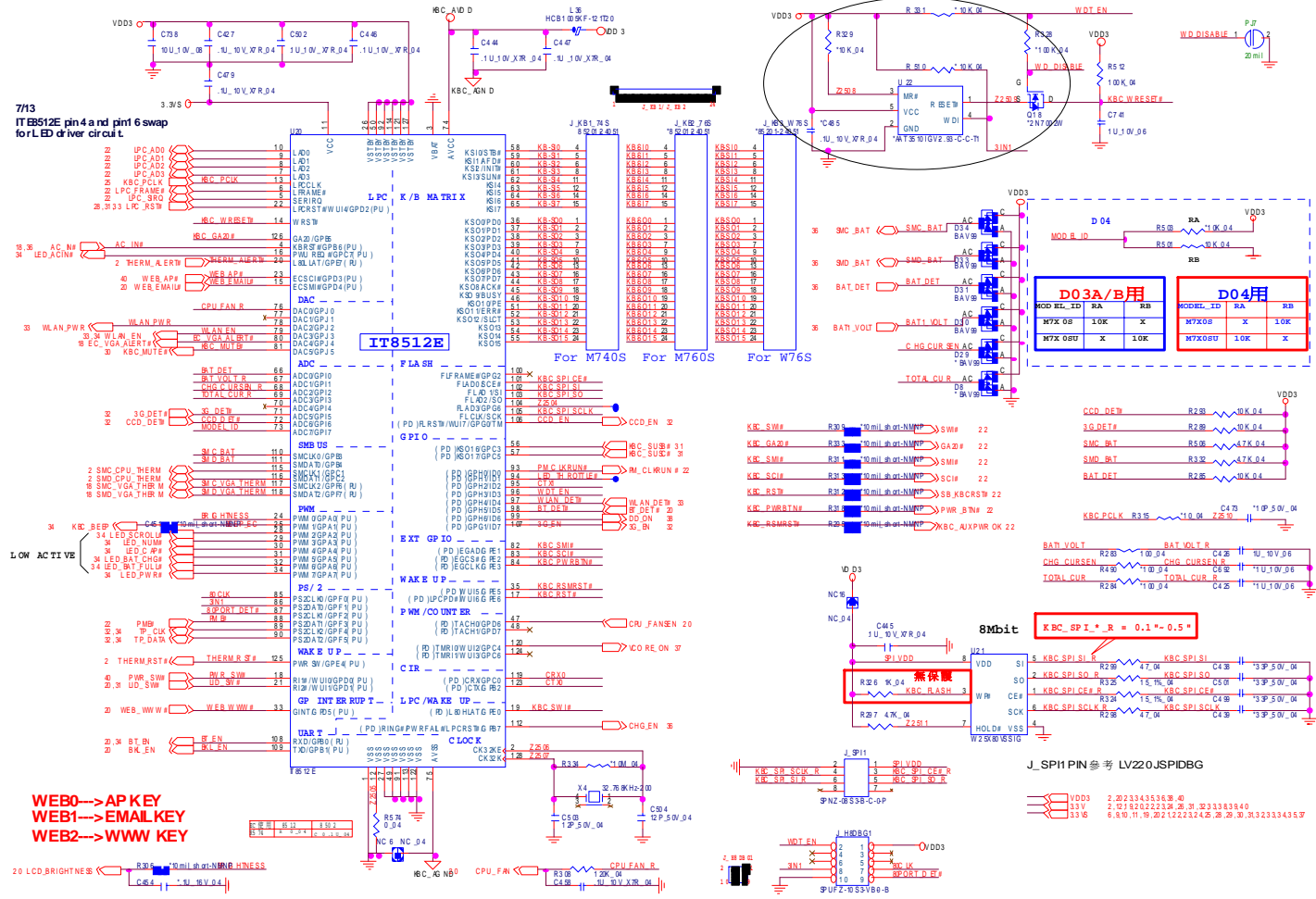

Sheet 20 of 38
KBC ITE8512E

B. Schematic Diagrams

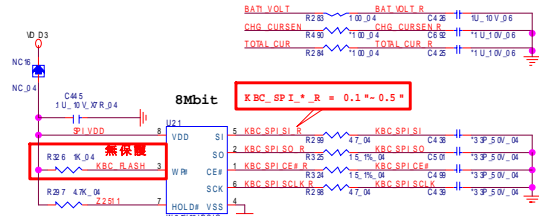
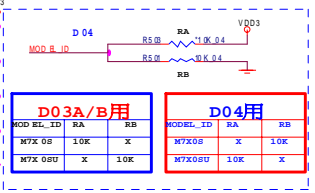

JMB385, Card Reader

Sheet 21 of 38
JMB385,
Card Reader

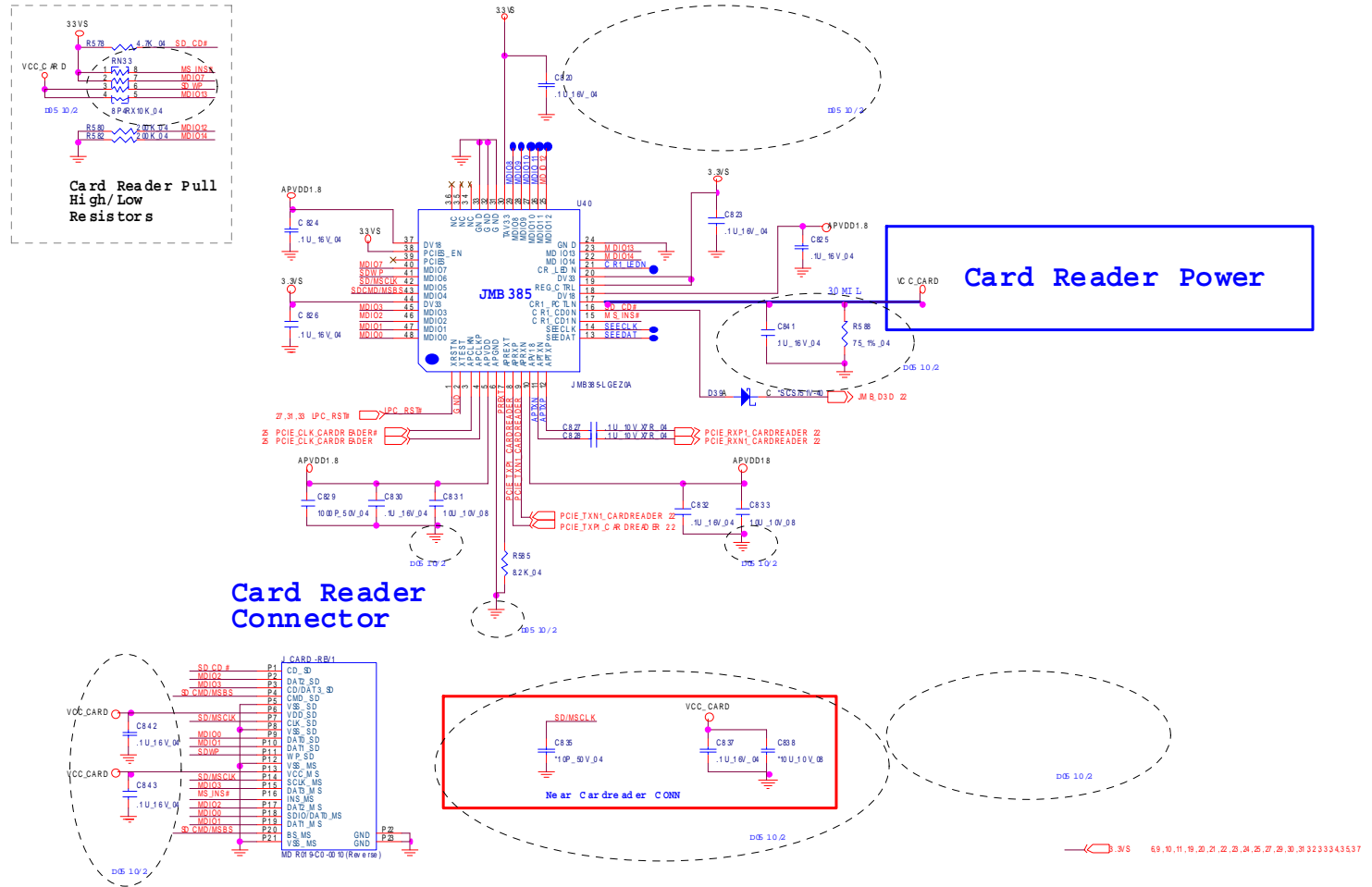

Audio Codec ALC662

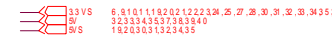
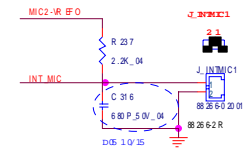
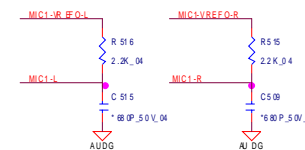
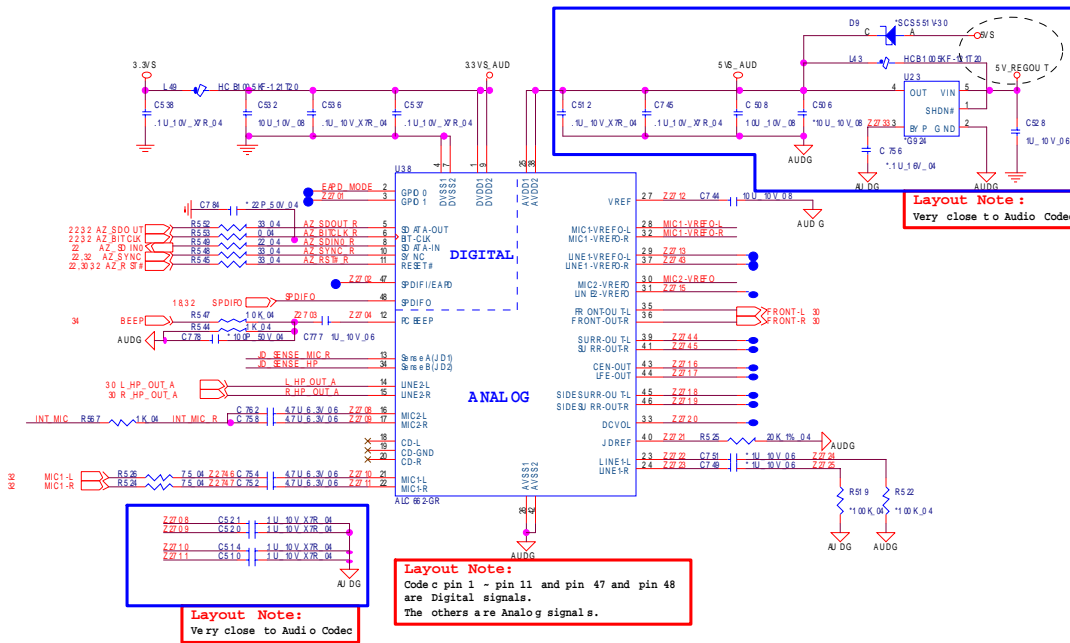

Sheet 22 of 38
Audio Codec
ALC662

New Card, Mini PCIE, USB

NEW CARD

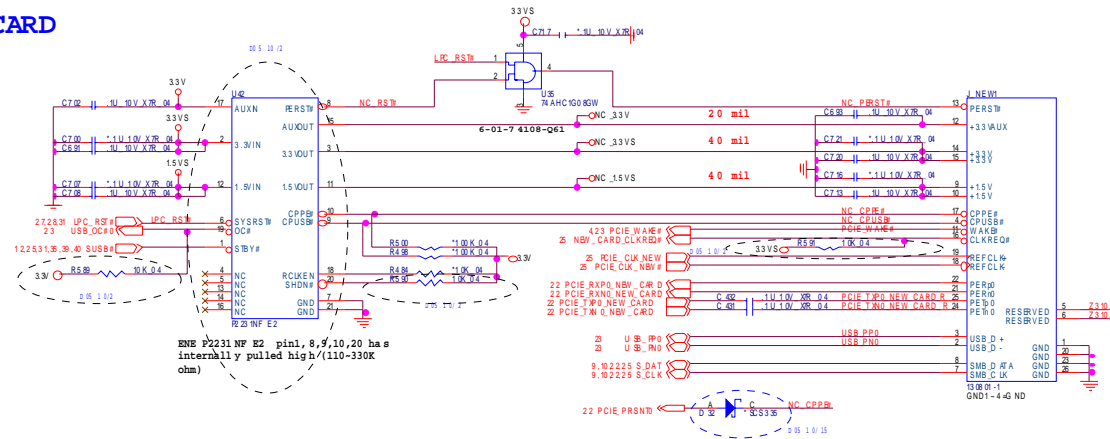

USB PORT

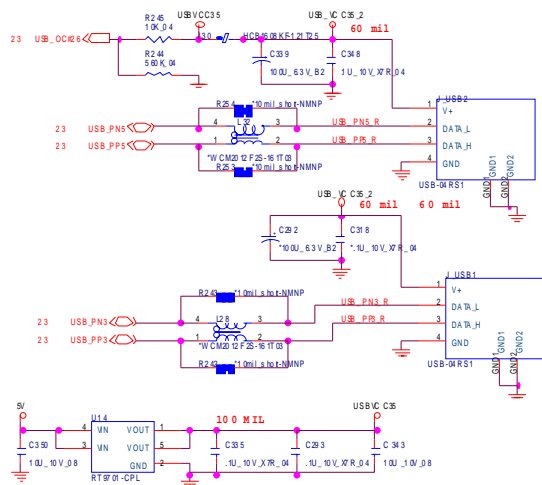

MINI CARD

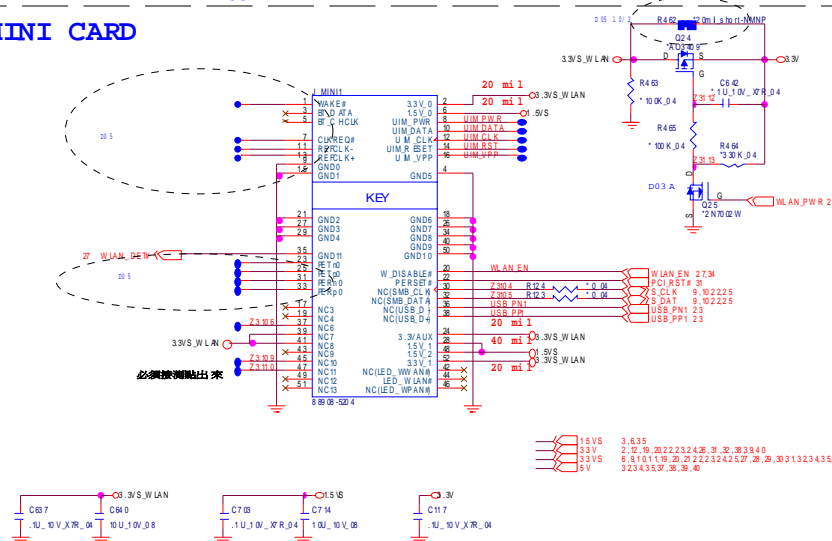

Sheet 26 of 38
New Card,
Mini PCIE, USB

B. Schematic Diagrams

LED, PC Beep, TP, FP

LED

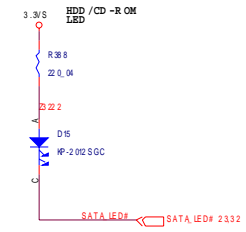
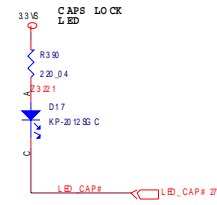
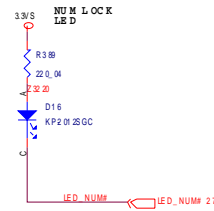
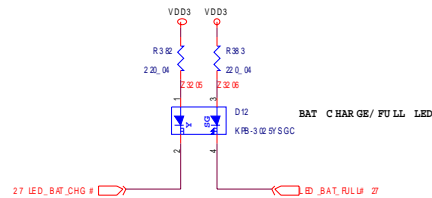
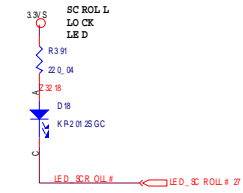
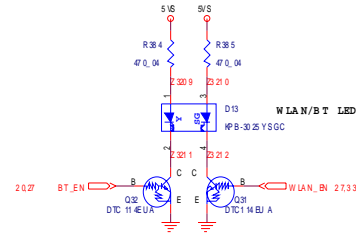
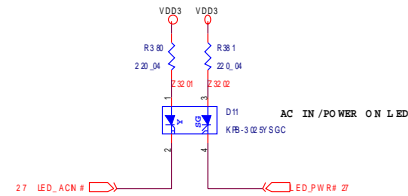

PC BEEP

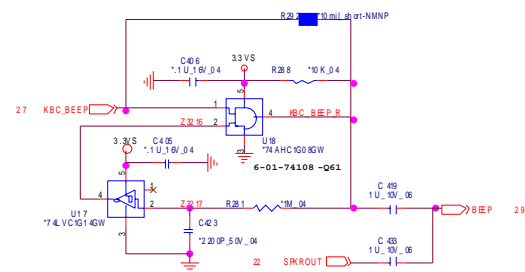

FP CONN

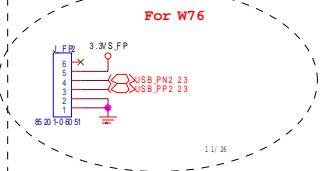
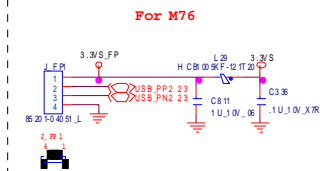

CLICK CONN For M76

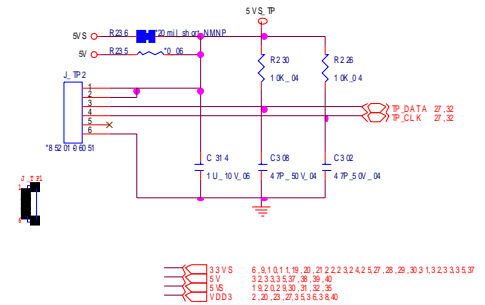

B.Schematic Diagrams

Sheet 27 of 38
 LED, PC Beep, TP, FP

System/Ext-VGA Power

1. 2VS, 1.5VS, 1.8VS, 3.3VS, 5VS

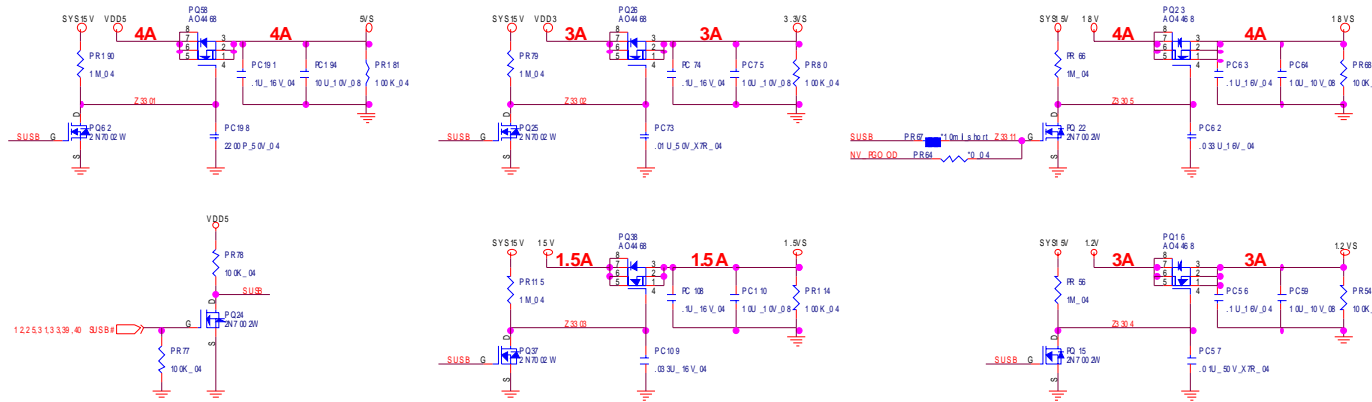

Sheet 28 of 38
System/Ext-VGA
Power

B. Schematic Diagrams

M760US 要上件

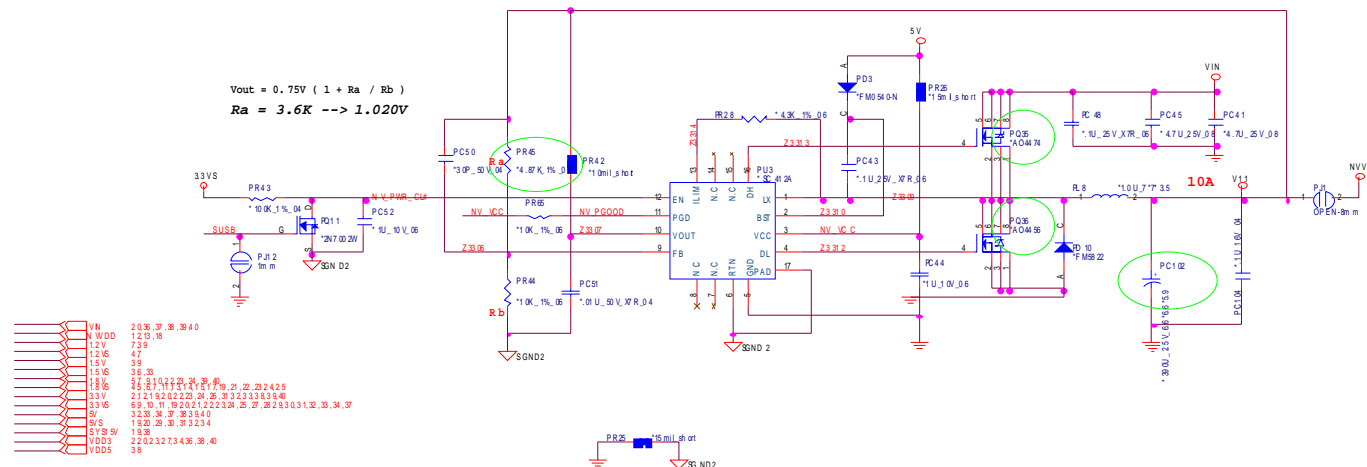

AC-IN, Charger

Sheet 29 of 38
AC-IN, Charger

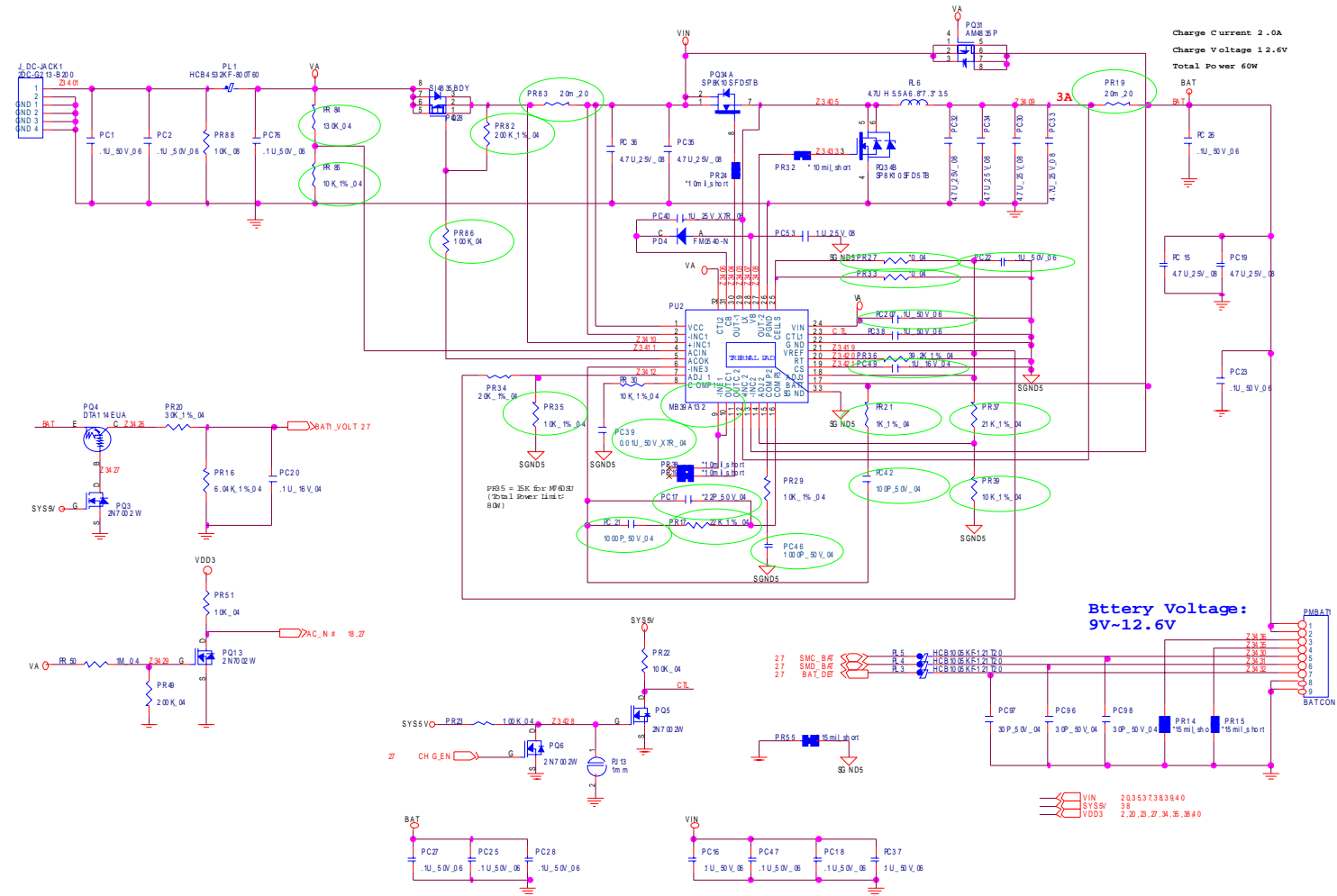

Charge Current 2.0A
Charge Voltage 12.6V
Total Power 60W

Battery Voltage:
9V-12.6V

VCORE

VCORE FOR PENRYN CPU

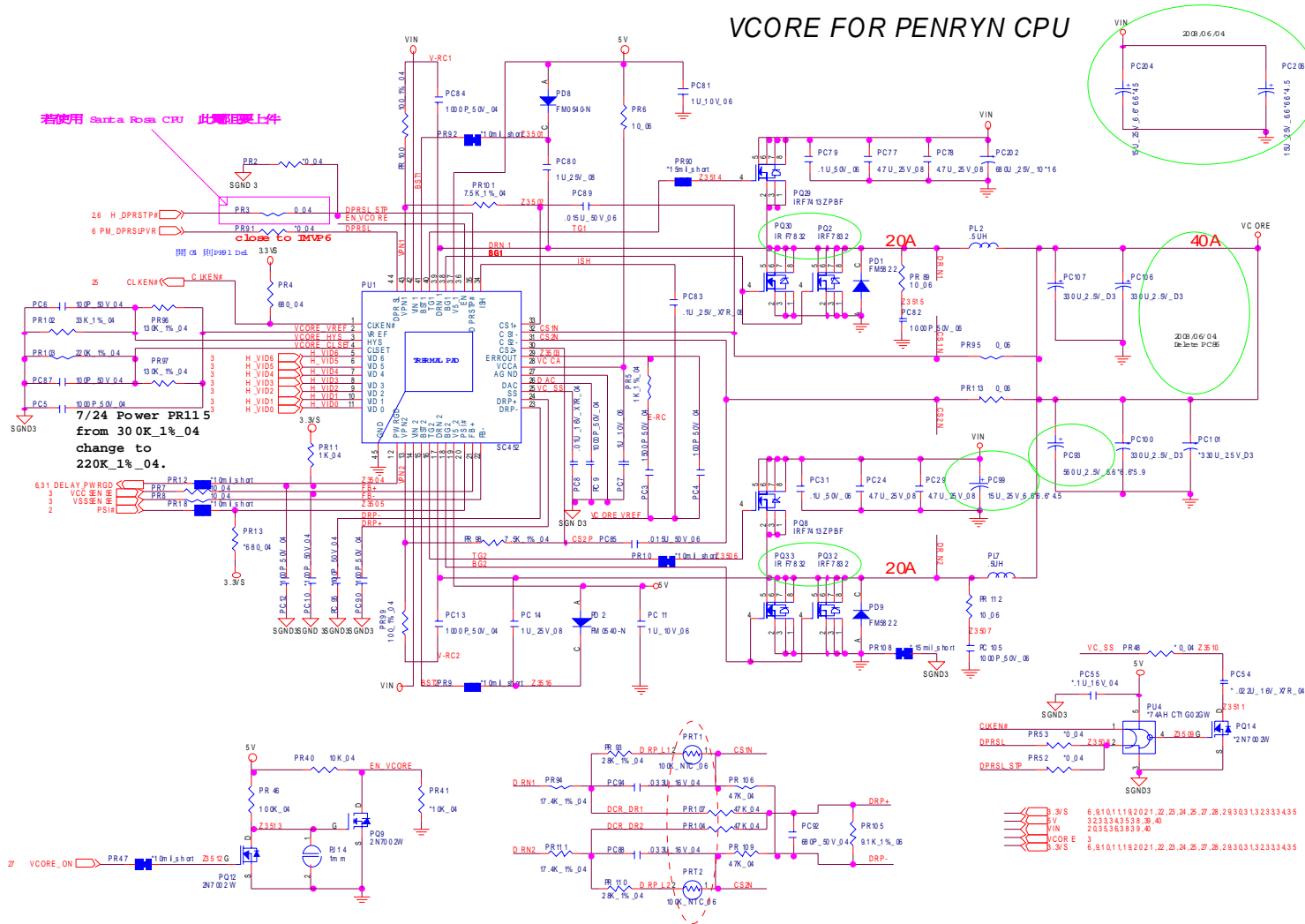

Sheet 30 of 38
VCORE

Schematic Diagrams

VDD3, VDD5)

Sheet 31 of 38
VDD3, VDD5

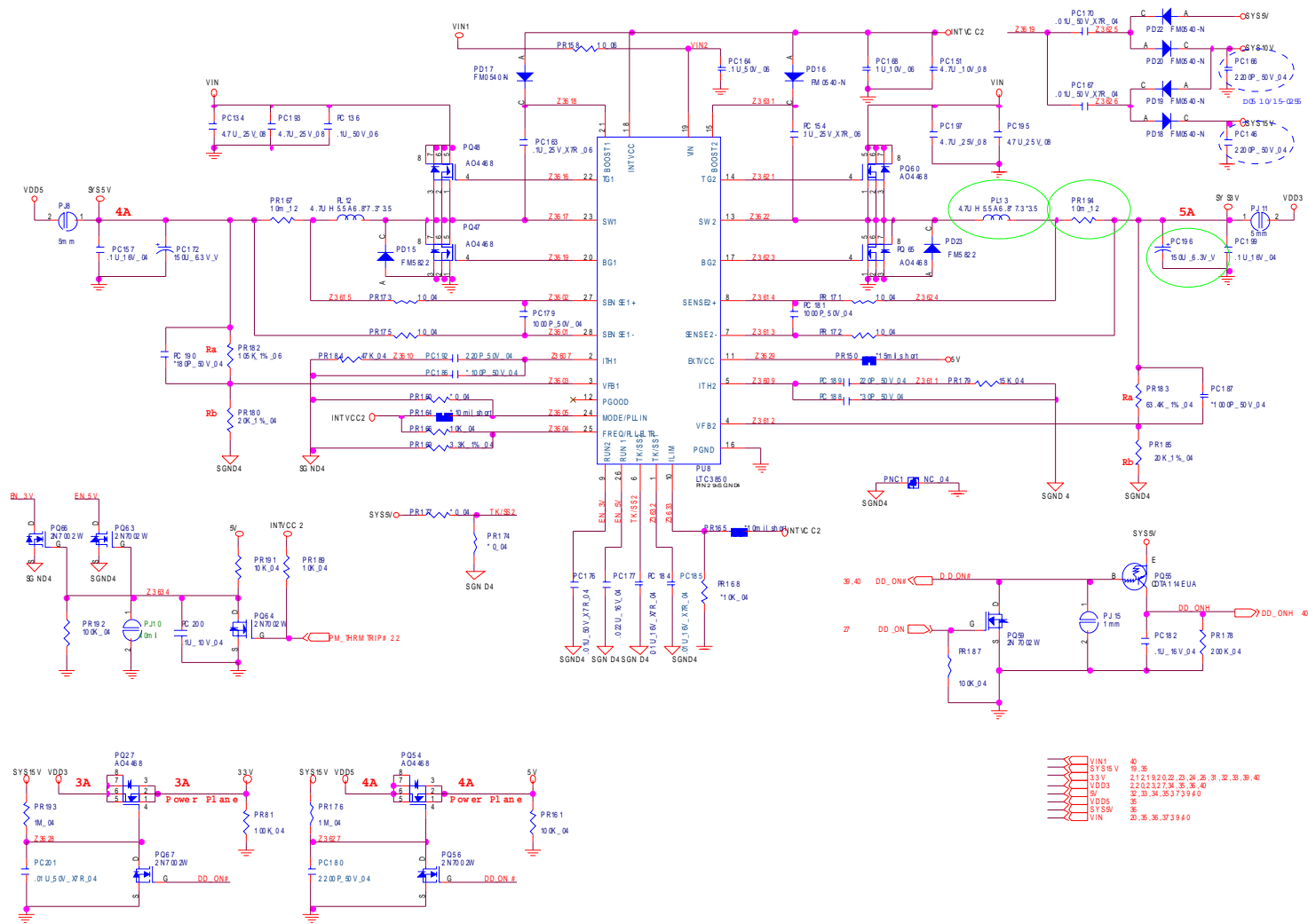

1.05VS, 1.2V, 1.5V

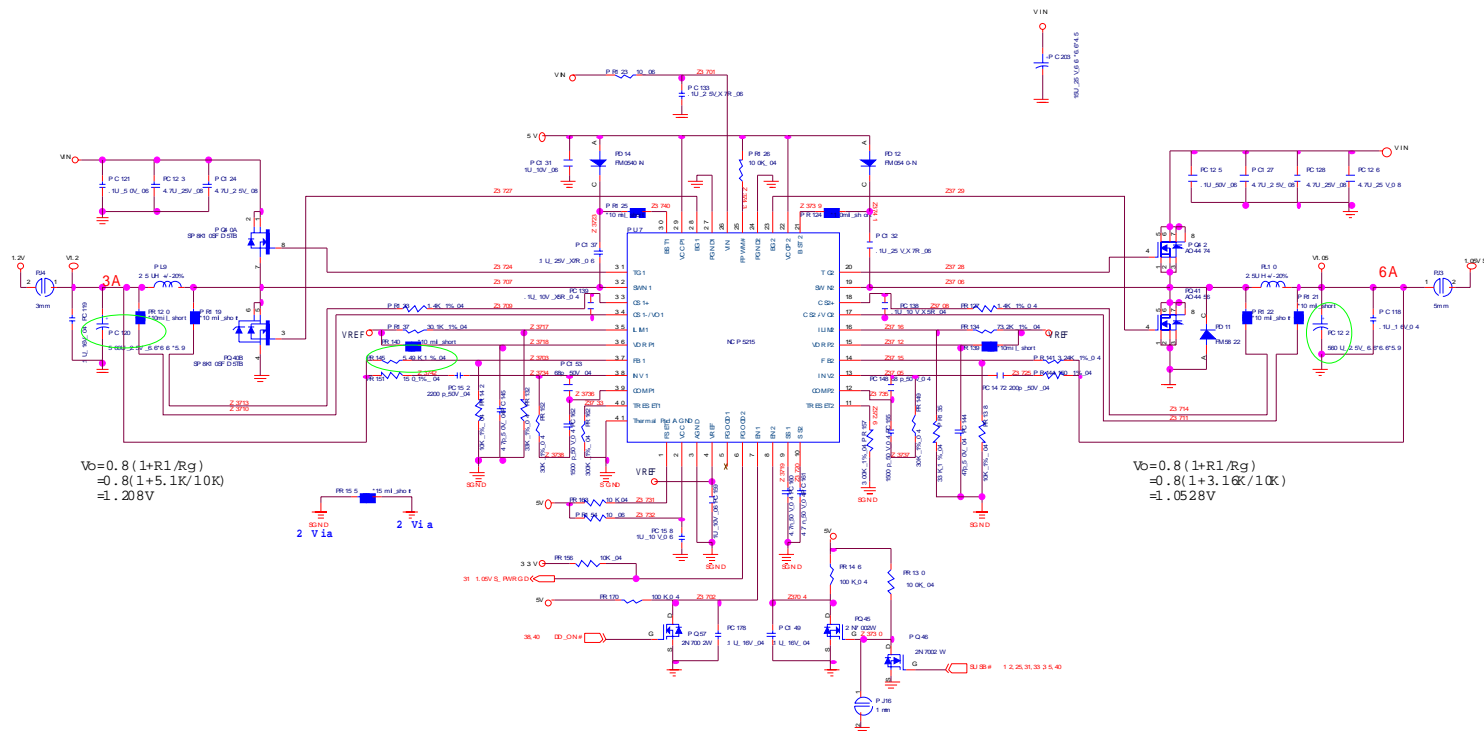

$$V_o = 0.8 \left(1 + \frac{R_1}{R_g} \right) = 0.8 \left(1 + \frac{5.1K}{10K} \right) = 1.208V$$

$$V_o = 0.8 \left(1 + \frac{R_1}{R_g} \right) = 0.8 \left(1 + \frac{3.16K}{10K} \right) = 1.0528V$$

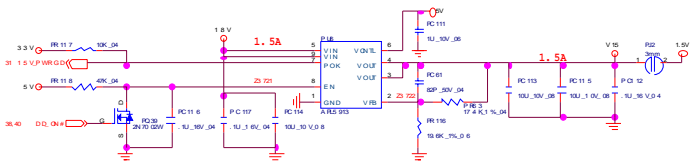

- 1.5V 2.5, 5, 6, 7, 8, 9, 10, 11, 12, 13, 14, 15, 16, 17, 18, 19, 20, 21, 22, 23, 24, 25, 26, 27, 28, 29, 30, 31, 32, 33, 34, 35, 36, 37, 38, 39, 40
- 1.2V 2.5, 5, 6, 7, 8, 9, 10, 11, 12, 13, 14, 15, 16, 17, 18, 19, 20, 21, 22, 23, 24, 25, 26, 27, 28, 29, 30, 31, 32, 33, 34, 35, 36, 37, 38, 39, 40
- 1.05V 2.5, 5, 6, 7, 8, 9, 10, 11, 12, 13, 14, 15, 16, 17, 18, 19, 20, 21, 22, 23, 24, 25, 26, 27, 28, 29, 30, 31, 32, 33, 34, 35, 36, 37, 38, 39, 40

Sheet 32 of 38
1.05VS, 1.2V, 1.5V

B. Schematic Diagrams

Schematic Diagrams

1.8V, 0.9VS

B.Schematic Diagrams

Sheet 33 of 38
1.8V, 0.9VS

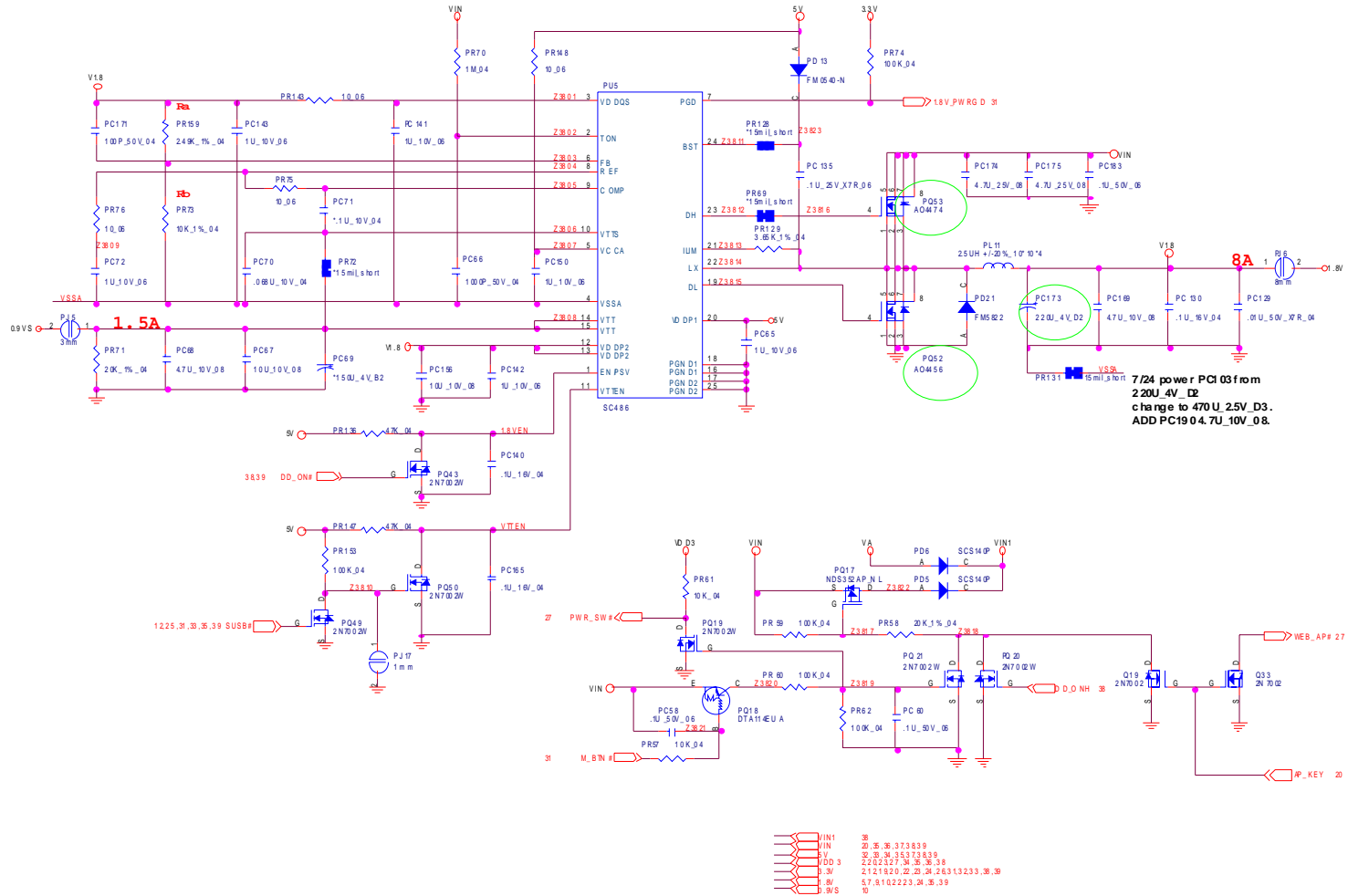

Click BD, Finger BD for M76

CLICK BOARD

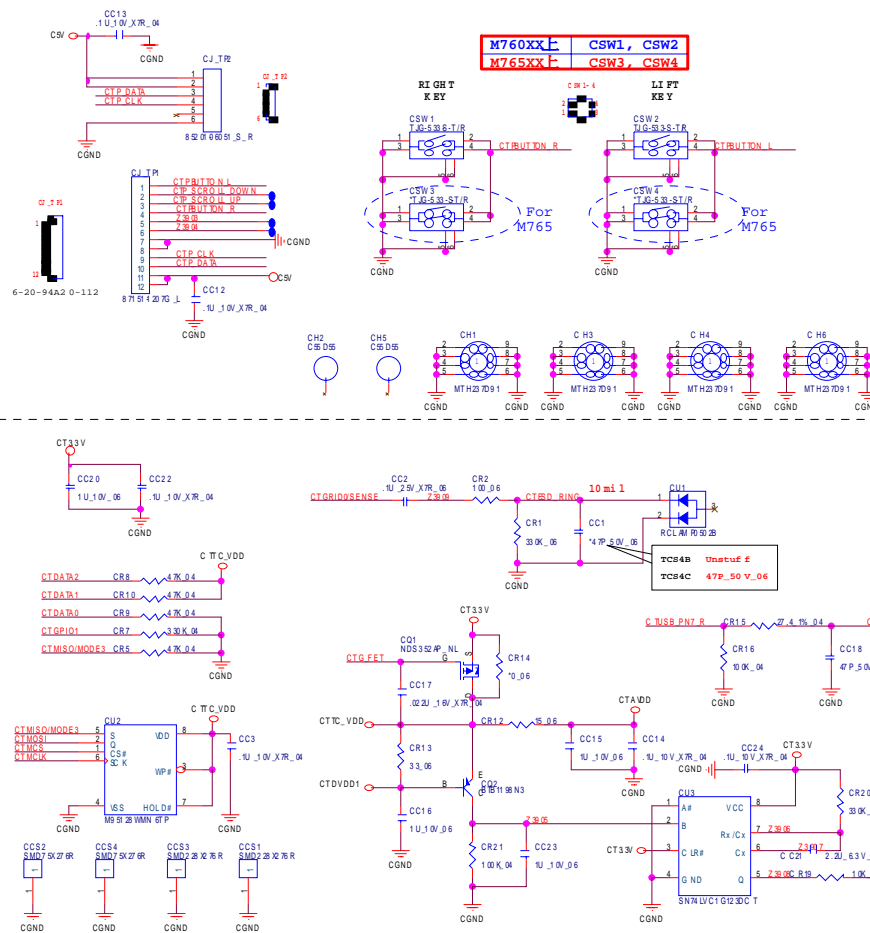

FINGER BOARD

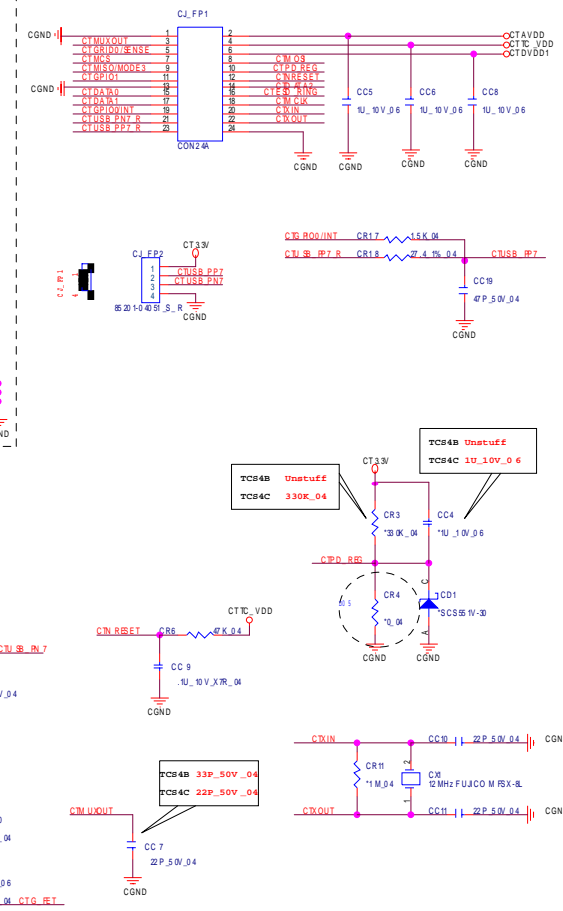

Sheet 34 of 38
Click BD, Finger BD
for M76

Multi Function Board

SPEAKER CONNECTOR

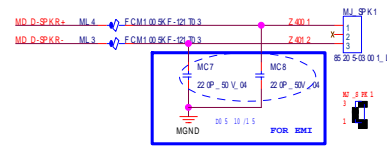

MULTI I/O CONN

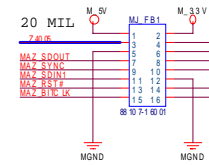

CCD

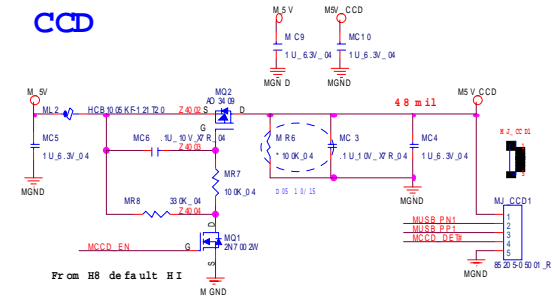

Sheet 35 of 38
Multi Function
Board

RJ-11

須與其他零件或線路
淨空 2.5mm 以上



MDC MODULE

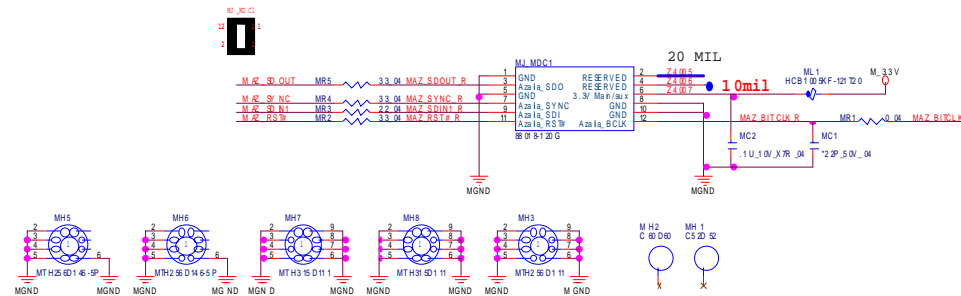

Audio Board

USB PORT

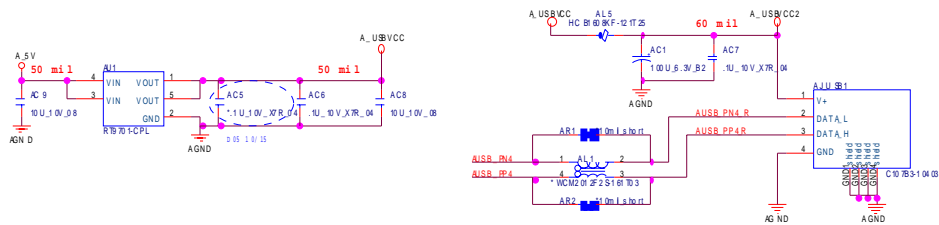

Sheet 36 of 38
Audio Board

AUDIO JACK

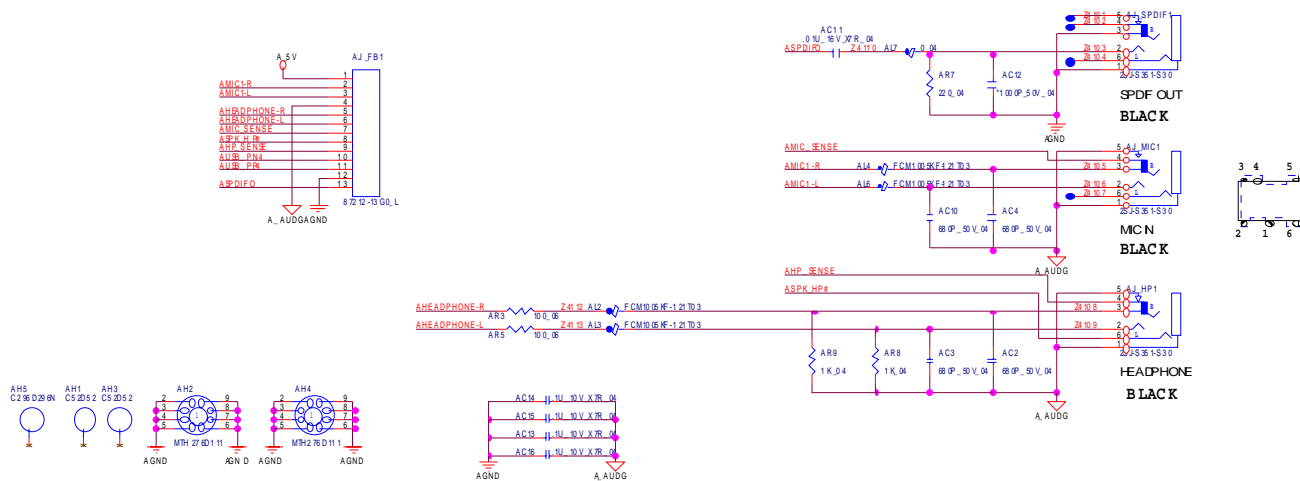

Power Switch Board for M74

POWER SW & POWER LED FOR M74

Sheet 37 of 38
Power Switch
Board for M74

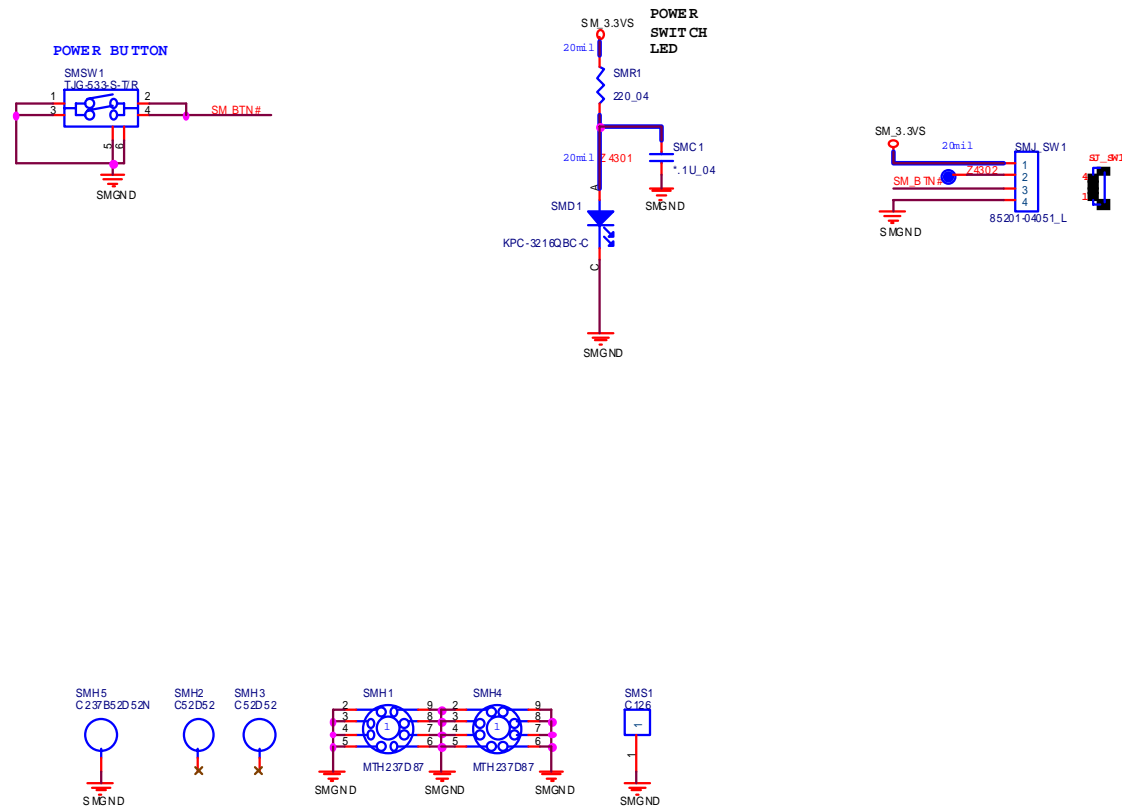

External ODD Board for W76

ODD BOARD FOR W76

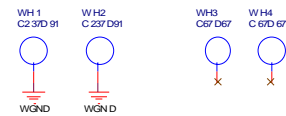
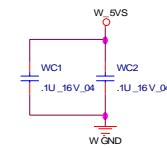
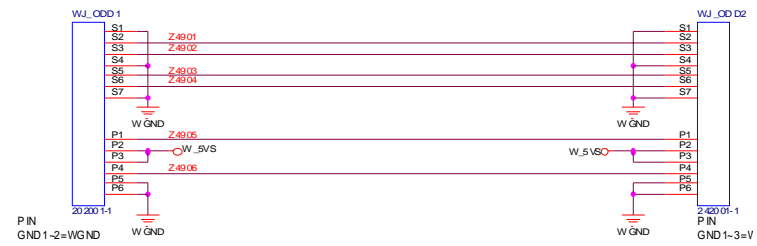

Sheet 38 of 38
External ODD
Board for W76