

Lindbergh Schematic Document

uFCPGA Northwood

2002-10-23

Rev:X025

Compal Electronics, Inc.		
Title	Cover Sheet	
Size	Document Number	Rev
	ADQ00/LA-1351	X025
Date:	Wednesday, October 23, 2002	
	Sheet	1 of 50

Block Diagram

ADQ00(Lindbergh) ↔ Inspiron
 ADQ10(Baekland) ↔ Latitude

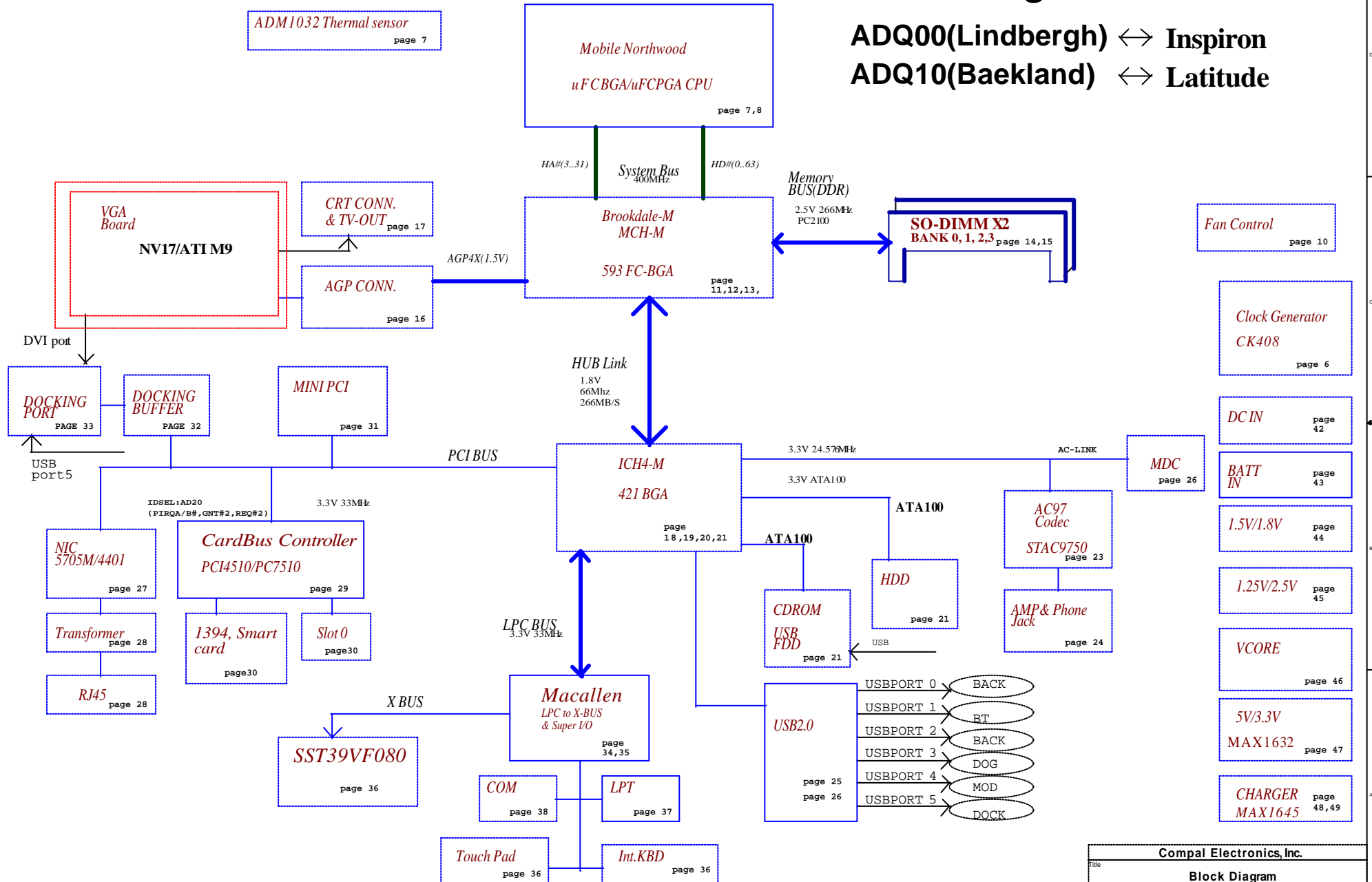

PM TABLE

power plane State	+3VALW +5VALW	+3VSRC +3VSUS +5VSUS +2.5VSUS +1.8VSUS +1.5VSUS +12V	+3VRUN +5VRUN +1.8VRUN +1.5VRUN +VCC_CORE
s0	ON	ON	ON
s1	ON	ON	ON
s3	ON	ON	OFF
s5 s4/AC	ON	OFF	OFF
s5 s4/AC don't exist	OFF	OFF	OFF

PCI TABLE

PCIDEVICE	IDSEL	REQ#/GNT#
CARDBUS	AD17	1
LAN	AD16	4
DOCK	AD24	0
MINIPCI	AD19	3

USB TABLE

USB PORT#	DESTINATION
0	BACK
1	BLUETOOTH
2	BACK
3	DOG
4	MOD
5	DOCK

BOM Structure:

Backland- 43122231001, with 1@

Lindbergh- 43122231002, with 2@

Note: "@" means all model depop
 "?" means Kapalua pop only (ie Lindbergh depop)
 "#" means Lindbergh pop only (ie baekland depop)

Configuration List

BOM Structure		
Function	Lindbergh	Kapalua \ Baekland

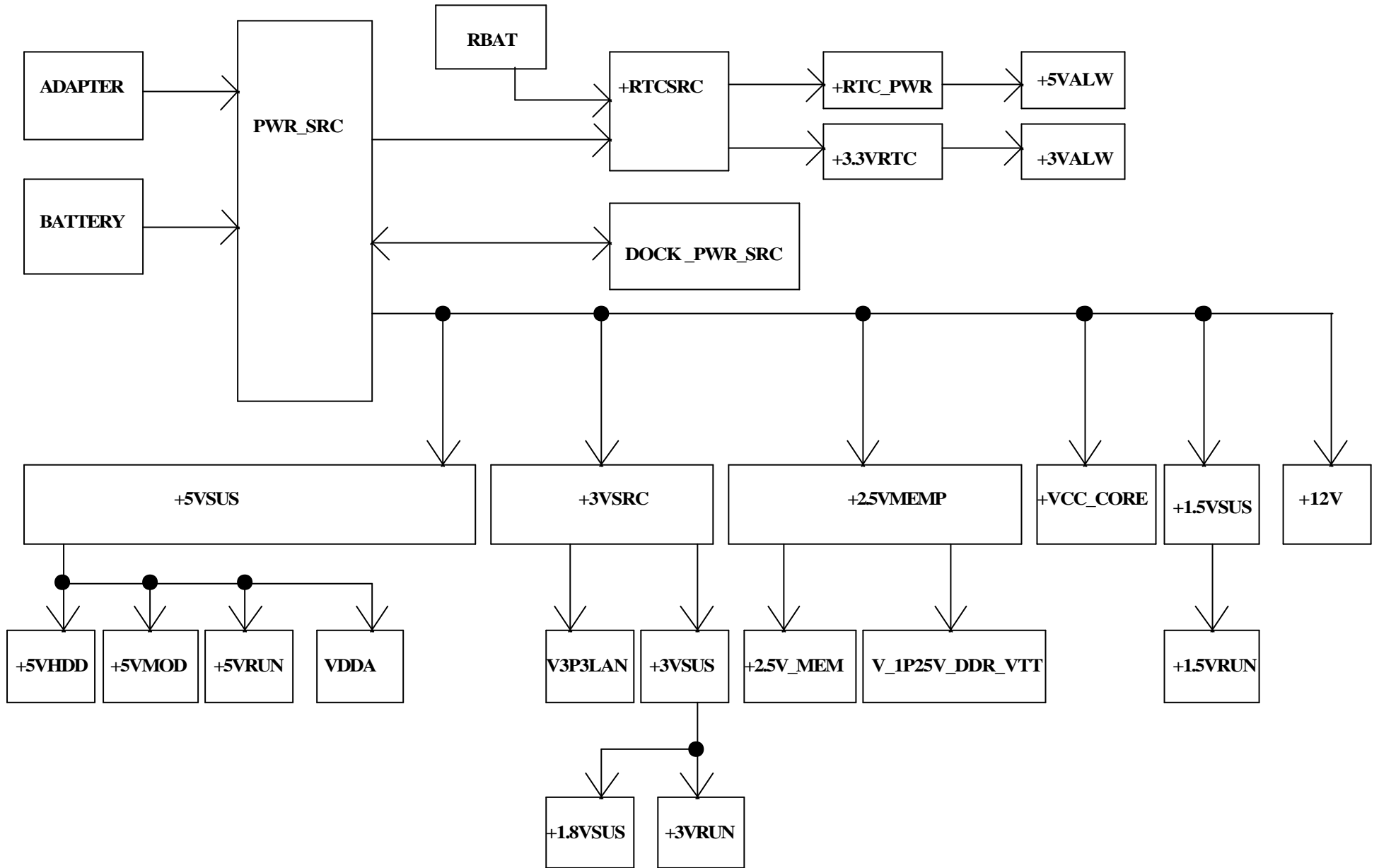

Compal Electronics, Inc.			
Title			
Power Rail			
Size	Document Number	Rev	X023
ADQ00/LA-1351			
Date	Wednesday, October 23, 2008	Page	4 of 50

ICH4-M

ICH_SMBCLK

ICH_SMBDATA

DIMM0

DIMM1

+3VRUN

CK_SCLK

CLK GEN.

CK_SDATA

V_3P3_LAN

LAN_SMBCLK

NIC

LAN_SMBDATA

MPCI

SIO
Macallen

CLK_SMB

DAT_SMB

24C05

ADM1032

DH PORT

DOCK_SMB_CLK

DOCK_SMB_DAT

DOCKING

SBAT_SMBCLK

SBAT_SMBDAT

2'nd BATTERY

VGA
Inverter & ADM1032

PBAT_SMBCLK

PBAT_SMBDAT

1'nd BATTERY

CHARGER

+3VALW

+5VALW

+5VALW

+5VALW

+3VSUS

7002

7002

7002

7002

7002

7002

7002

7002

Compal Electronics, Inc.

Title			SMBUS TOPOLOGY		
Size	Document Number	Rev			
	ADQ00/LA-1351	X025			
Date:	Wednesday, October 23, 2008	5	of	50	

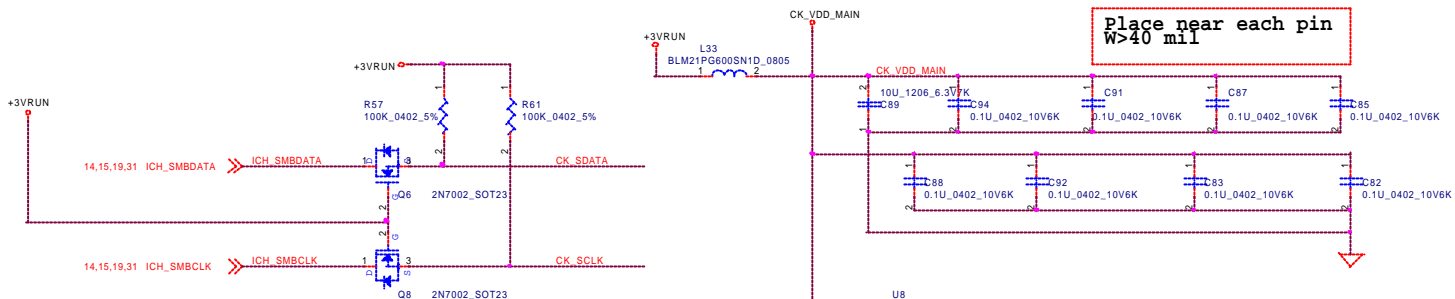

Place near each pin
W>40 mil

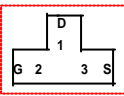

2N7002

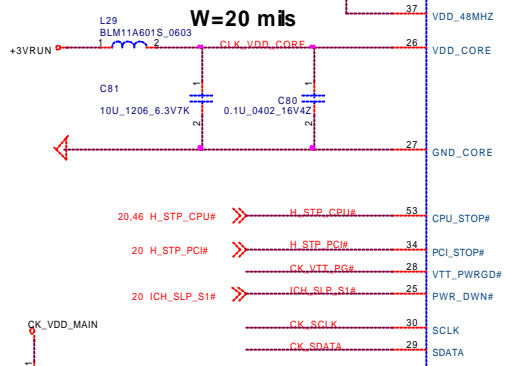
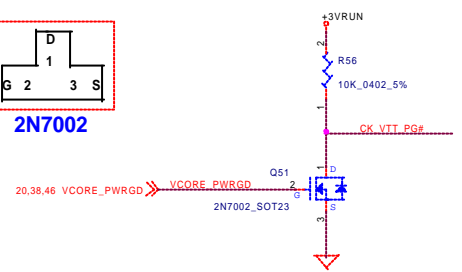

W=20 mils

CK408

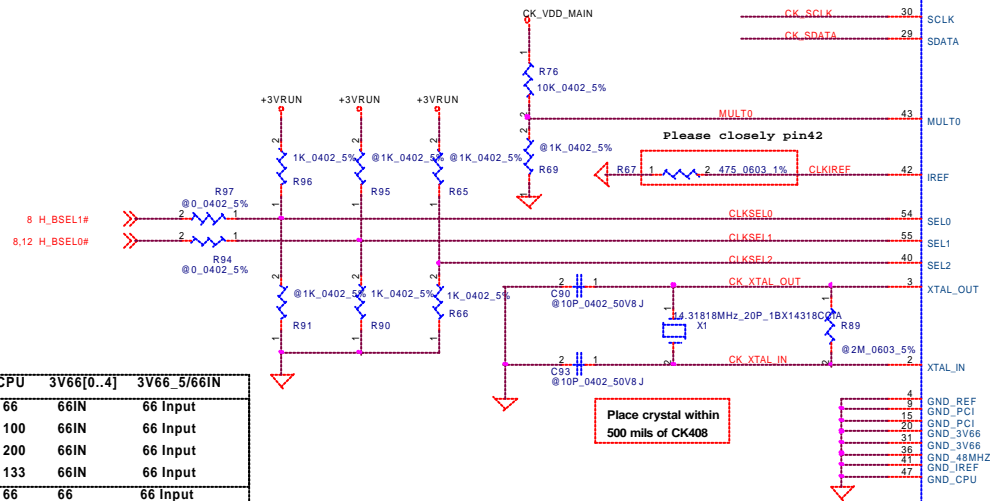

Please closely pin42

Place crystal within
500 mils of CK408

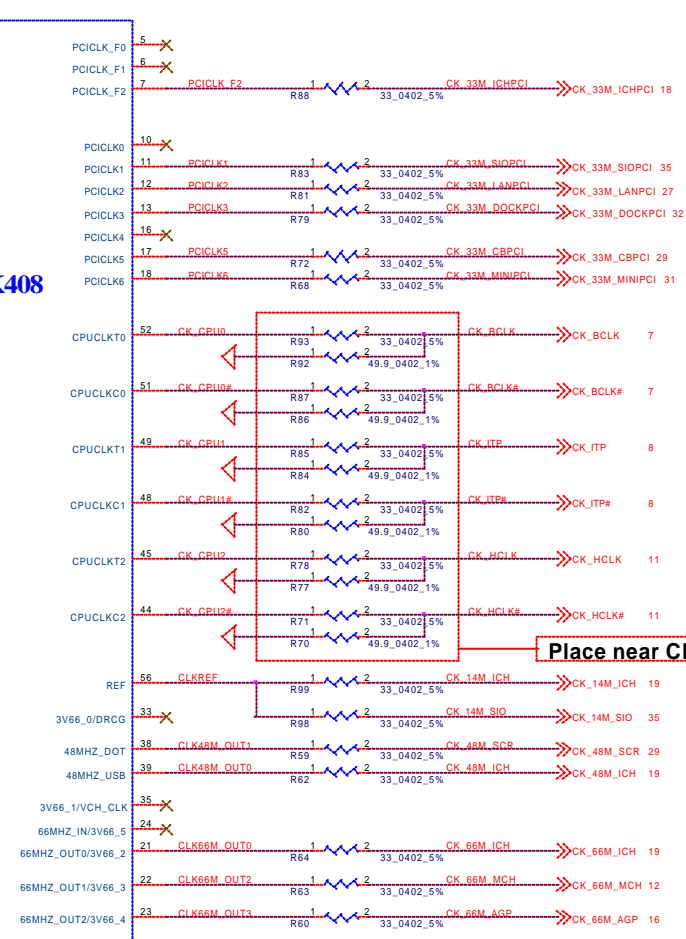

Place near CK408

S2	S1	S0	CPU	3V66[0..4]	3V66_5/66IN
1	0	0	66	66IN	66 Input
1	0	1	100	66IN	66 Input
1	1	0	200	66IN	66 Input
1	1	1	133	66IN	66 Input
0	0	0	66	66	66 Input
0	0	1	100	66	66 Input
0	1	0	200	66	66 Input
0	1	1	133	66	66 Input
Mid	0	0	Hi-z	Hi-z	Hi-z
Mid	0	1	TCLK/2	TCLK/2	TCLK/2
Mid	1	0	Reserve	Reserve	Reserve
Mid	1	1	Reserve	Reserve	Reserve

Compal Electronics, Inc.

Clock Generator

ADQ00/LA-1351

Date: **Wednesday, October 23, 2002** 6 of 50

Mobile NorthWood

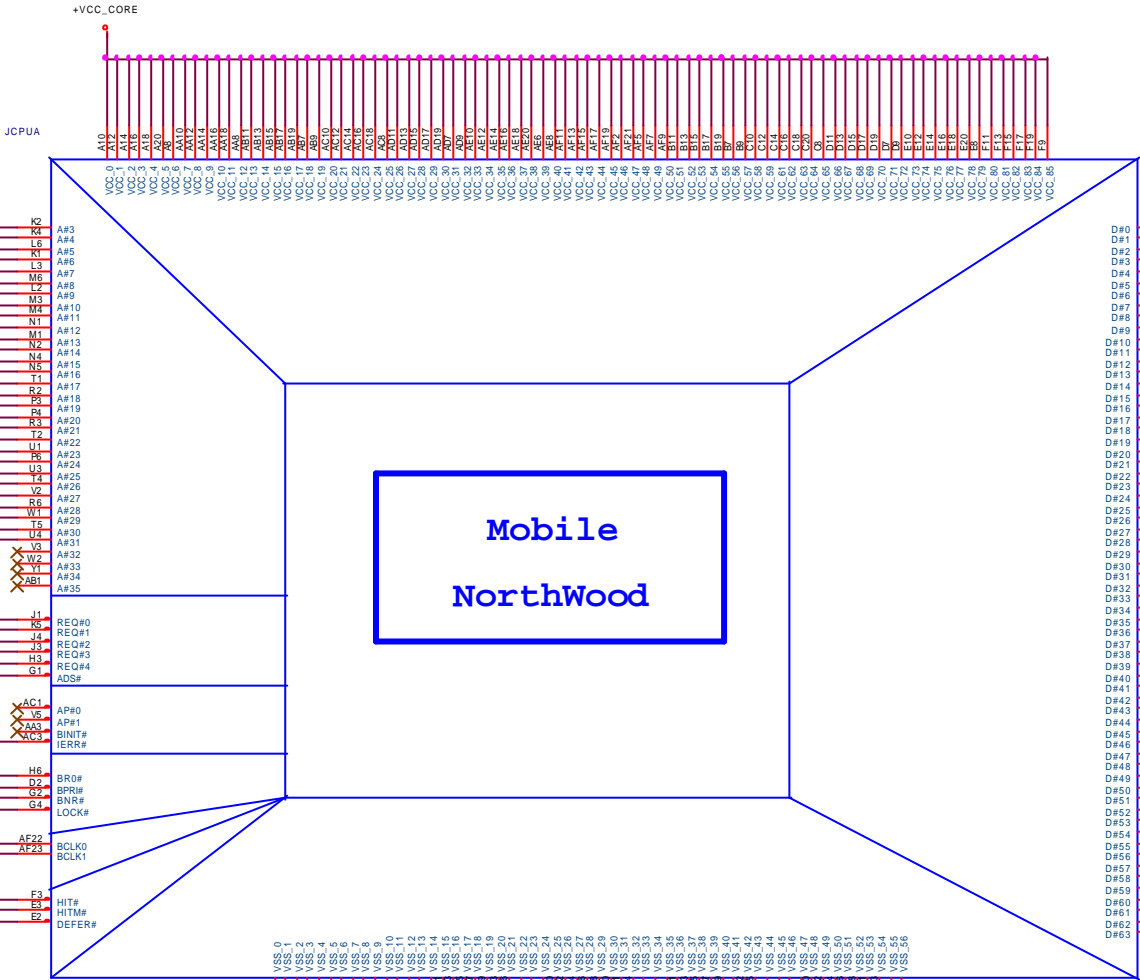

AMP_1565030-1_478P

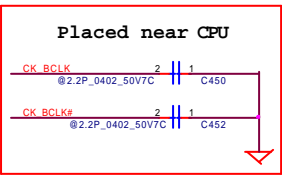

JCPU DELL P/N changed to IM568(mobil socket)

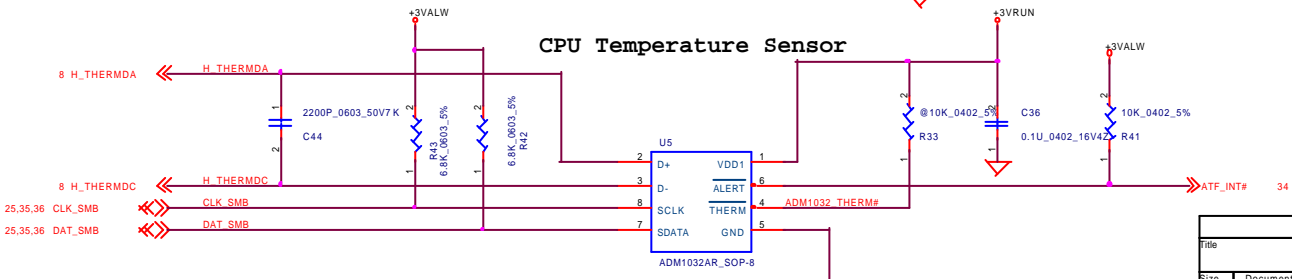

Mobile NorthWood

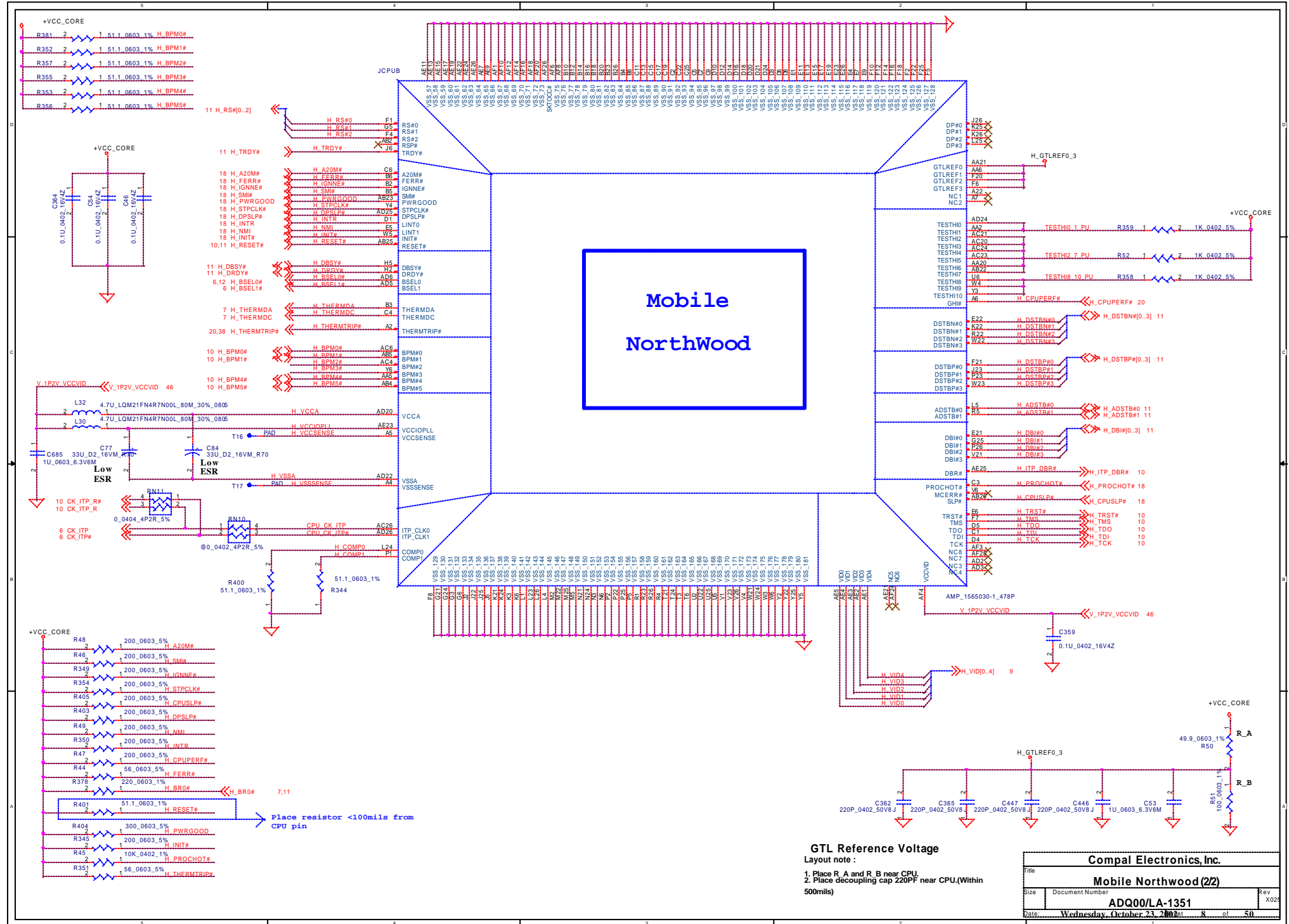

11 H_RS#[0..2]

11 H_TRDY#

18 H_A20M#
18 H_FERR#
18 H_IGNNE#
18 H_SM#
18 H_PWRGOOD
18 H_STPCLK#
18 H_DPSP#
18 H_INTR#
18 H_NMI#
18 H_INIT#
10,11 H_RESET#

11 H_DBSY#
11 H_DRDY#
6,12 H_BSEL0#
6 H_BSEL1#

7 H_THERMDA
7 H_THERMDC
20,38 H_THERMTRIP#

10 H_BPM0#
10 H_BPM1#
10 H_BPM4#
10 H_BPM5#

10 CK_ITP_R#
10 CK_ITP_R

6 CK_ITP#
6 CK_ITP#

0_0404_4P2R_5%

51.1_0603_1%

51.1_0603_1%

200_0603_5%

200_0603_5%

200_0603_5%

200_0603_5%

200_0603_5%

200_0603_5%

200_0603_5%

200_0603_5%

10K_0402_1%

156_0603_5%

Place resistor <100mils from CPU pin

GTL Reference Voltage

- Layout note:
1. Place R_A and R_B near CPU.
 2. Place decoupling cap 220PF near CPU.(Within 500mils)

Compal Electronics, Inc.		
Mobile NorthWood(2/2)		
ADQ00/LA-1351		
Size	Document Number	Rev
		X023
Date	Wednesday, October 23, 2002	8 of 50

Layout note :
 Place close to CPU. Use 2-3 vias per PAD.
 Place 22uF caps underneath balls on solder side.
 Place 10uF caps on the peripheral near balls.
 Use 2-3 vias per PAD.

Layout note :
 Place close to CPU power and ground pin as possible (<1inch)

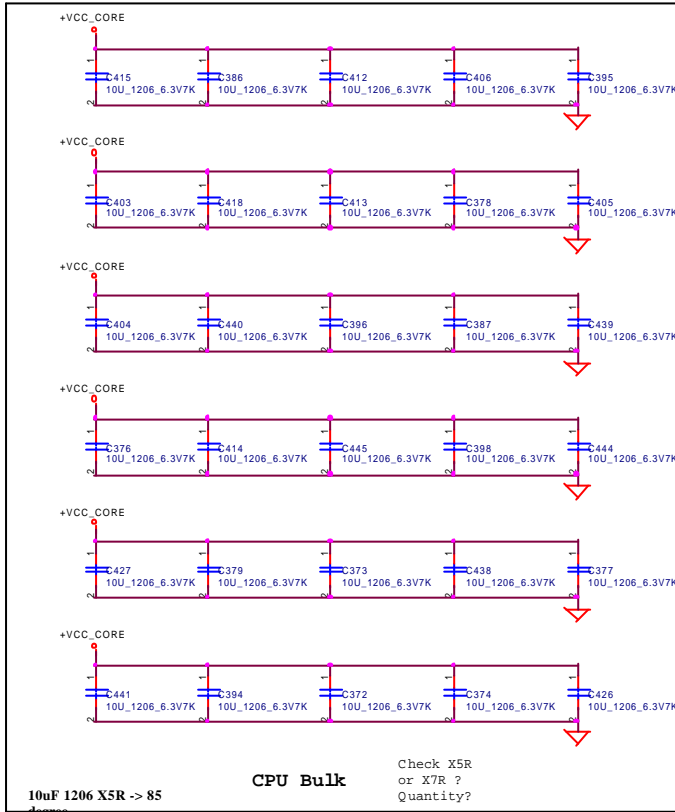

High Frequency Decoupling

To find 2V BULK CAP.

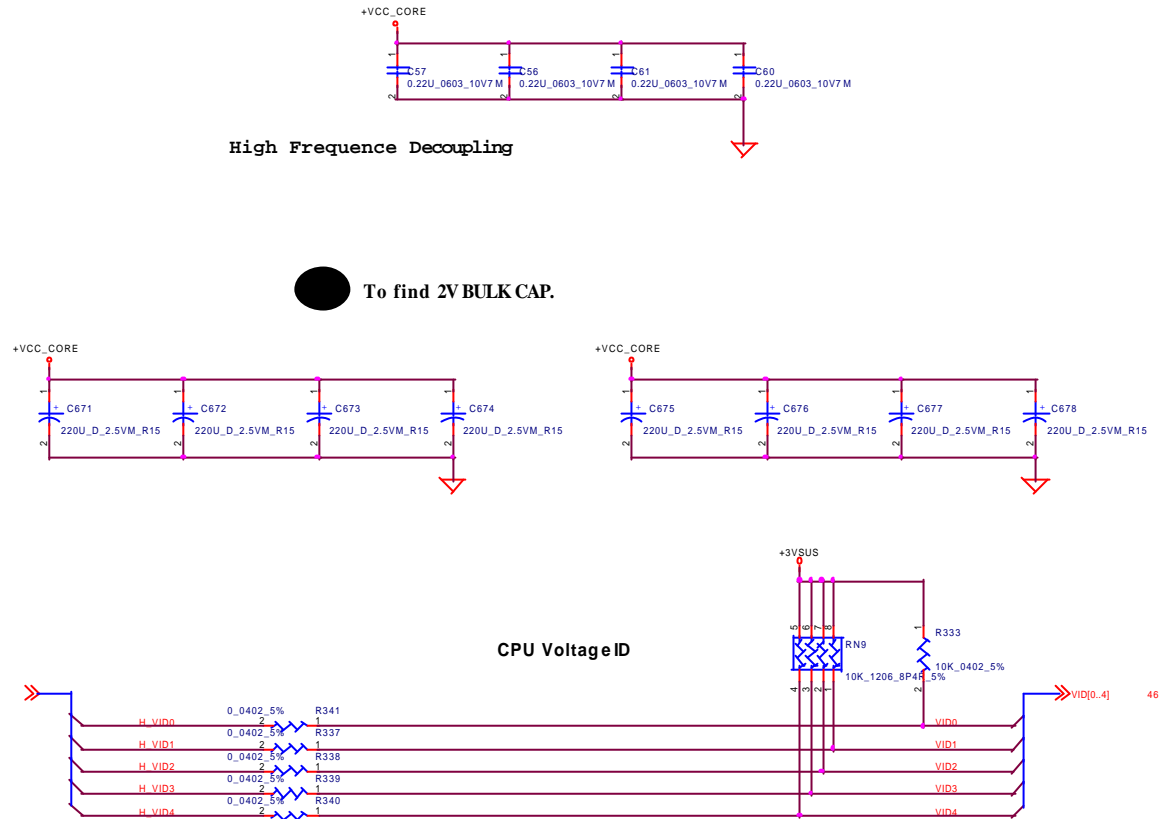

V I D					Vcore
VID4	VID3	VID2	VID1	VID0	V
0	1	0	0	0	1.350
0	1	0	0	1	1.300
0	1	0	1	0	1.250
0	1	0	1	1	1.200
0	1	1	0	0	1.150
0	1	1	0	1	1.100
0	1	1	1	0	1.050
0	1	1	1	1	1.000
1	0	0	0	0	0.975
1	0	0	0	1	0.950

FAN1 Control and Tachometer

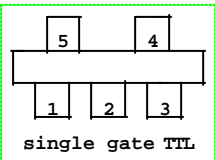
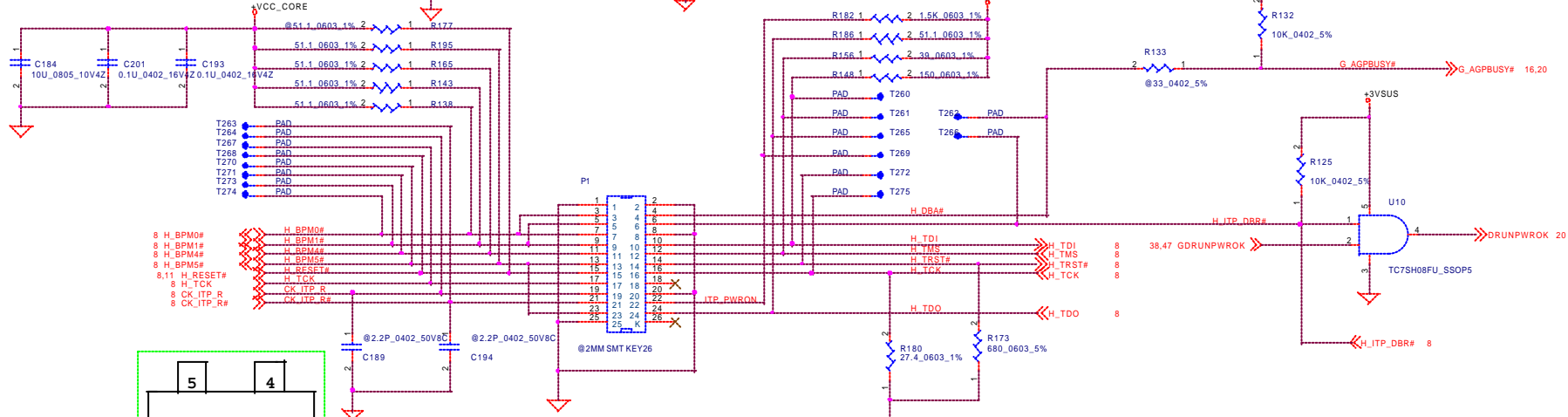
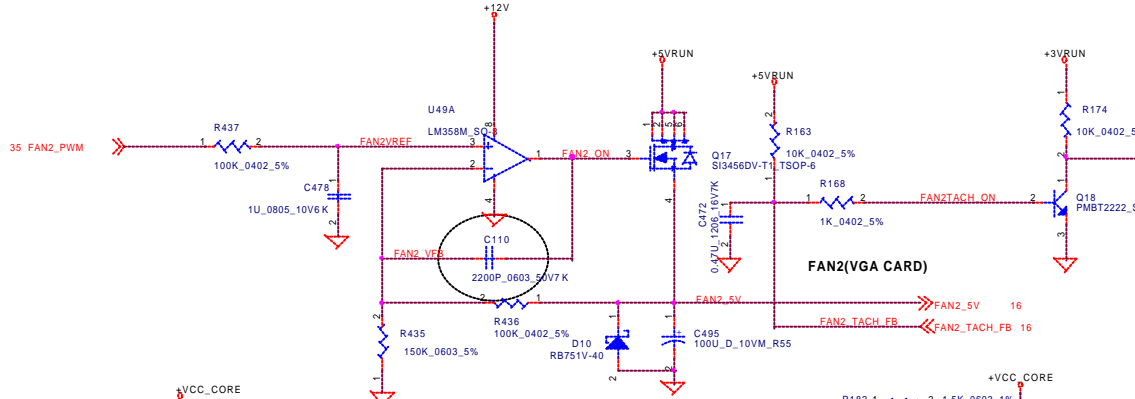
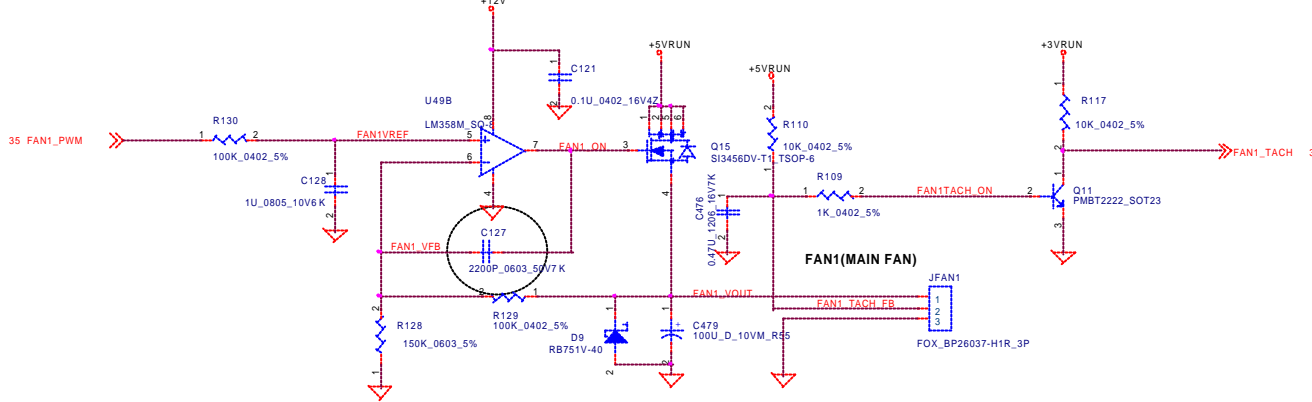
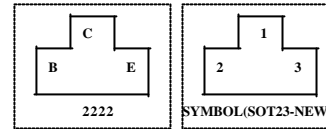

ITP Debug Connector

Compal Electronics, Inc.		
Title: ITP Debug CONN. & FAN		
Size	Document Number	Rev
	ADQ00/LA-1351	X025
Date:	Wednesday, October 23, 2002	10 of 50

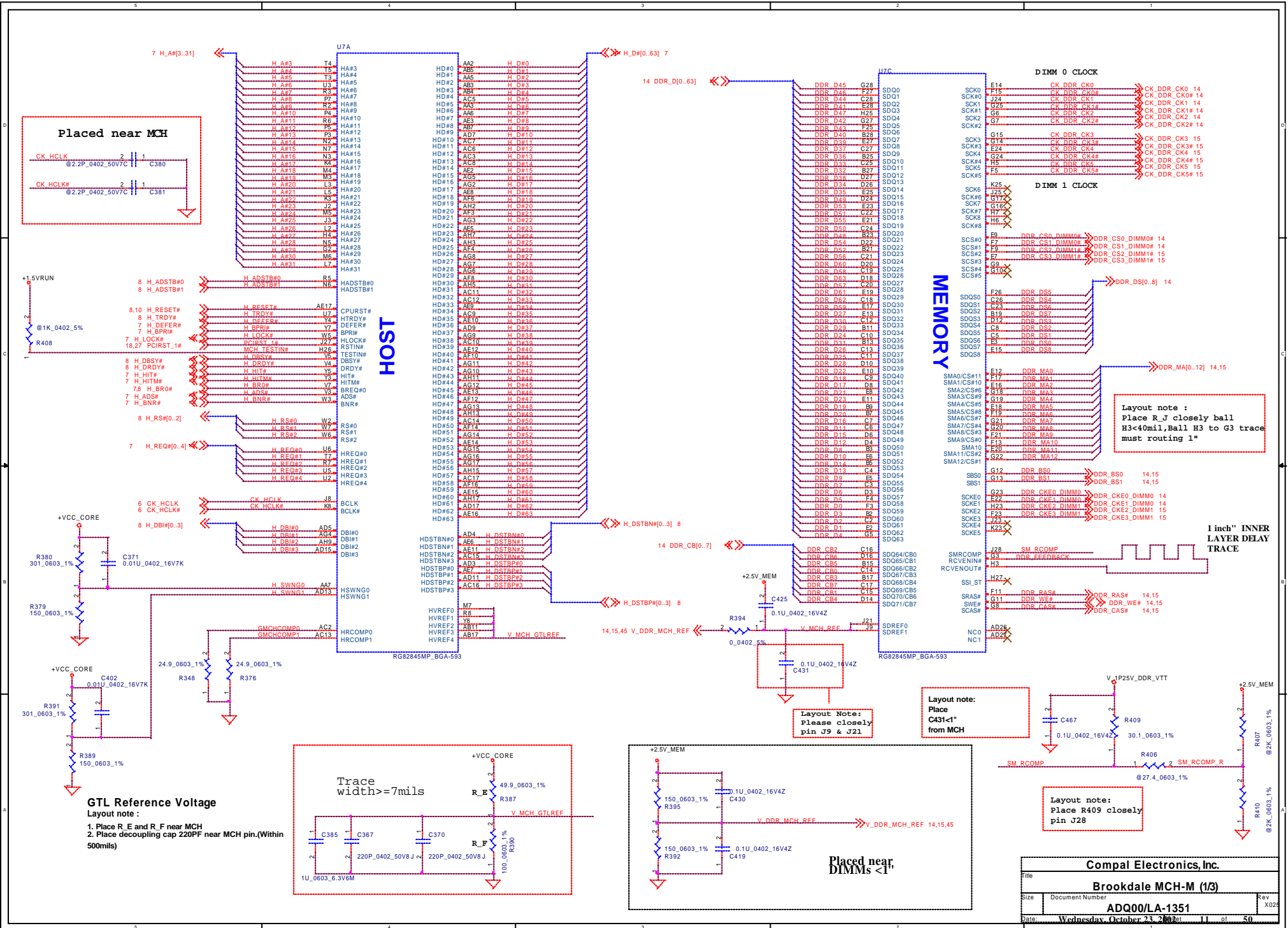

Placed near MCH

CK_HCLK @2.2P_0402_50V7C C380

CK_HCLK# @2.2P_0402_50V7C C381

HOST

MEMORY

Layout note :
Place R_J closely ball
H3<40mil, Ball H3 to G3 trace
must routing 1"

**1 inch" INNER
LAYER DELAY
TRACE**

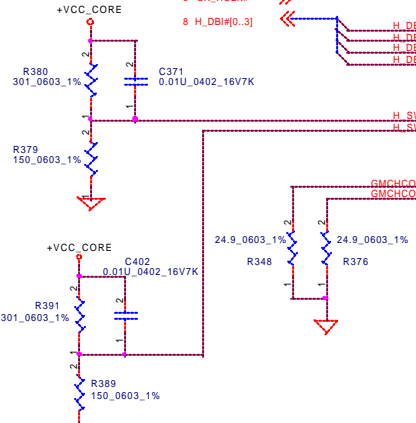

GTL Reference Voltage
Layout note :
1. Place R_E and R_F near MCH
2. Place decoupling cap 220PF near MCH pin.(Within 500mils)

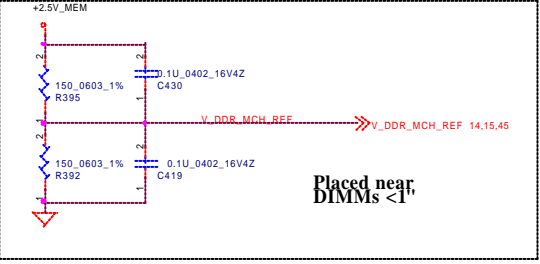
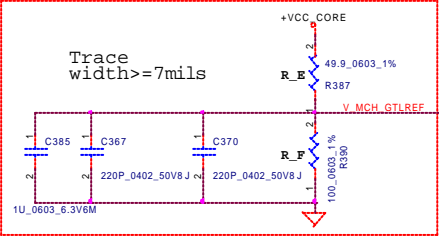

Layout note:
Place C431<1" from MCH

Layout note:
Place R409 closely pin J28

HUB Interface Reference

Layout note :

- 1. Place R_C and R_D in middle of Bus.
- 2. Place capacitors near MCH.

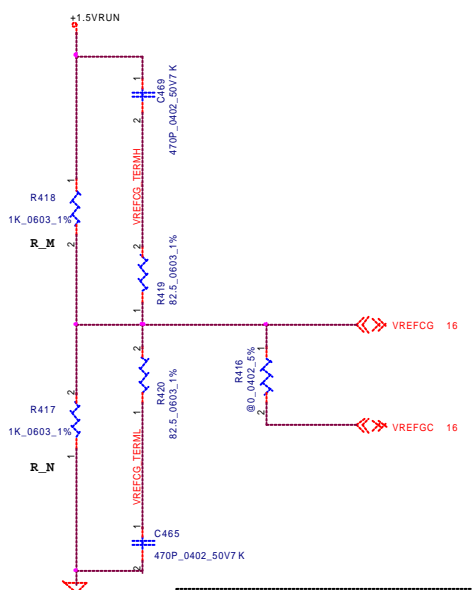
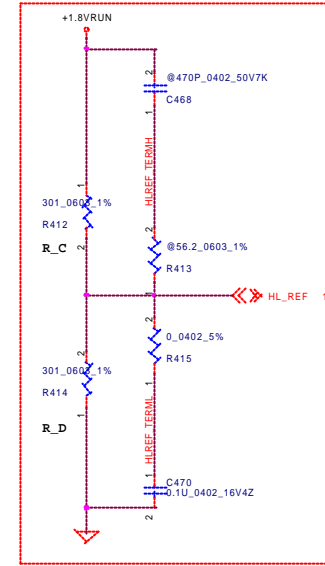

AGP Interface Reference

Place close to MCH-M

Compal Electronics, Inc.		
Brookdale MCH-M (2/3)		
Size	Document Number	Rev
	ADQ00/LA-1351	X023
Date	Wednesday, October 23, 2002 12 of 50	

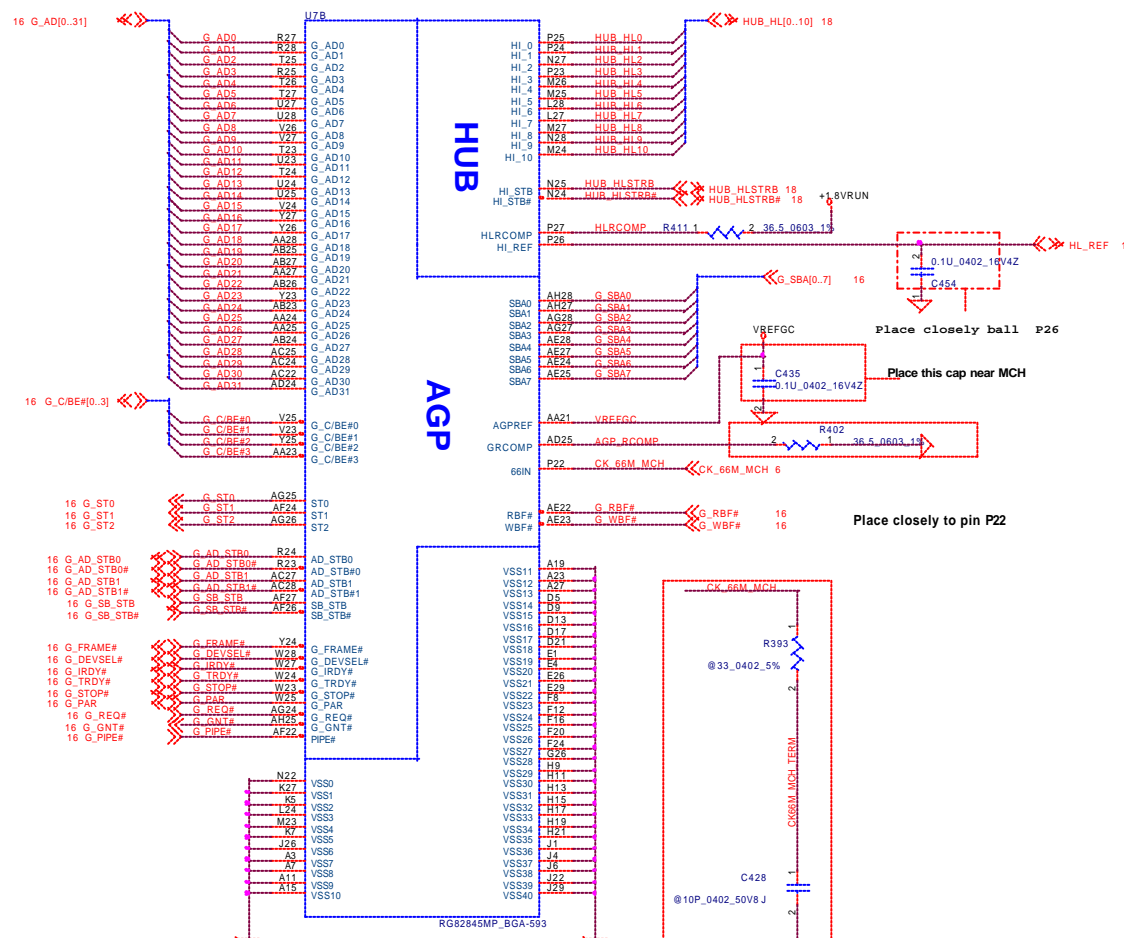

G_ST0
 0=System memory is DDR
 1=System memory is SDR

G_ST1
 0=533Mhz
 1=400Mhz

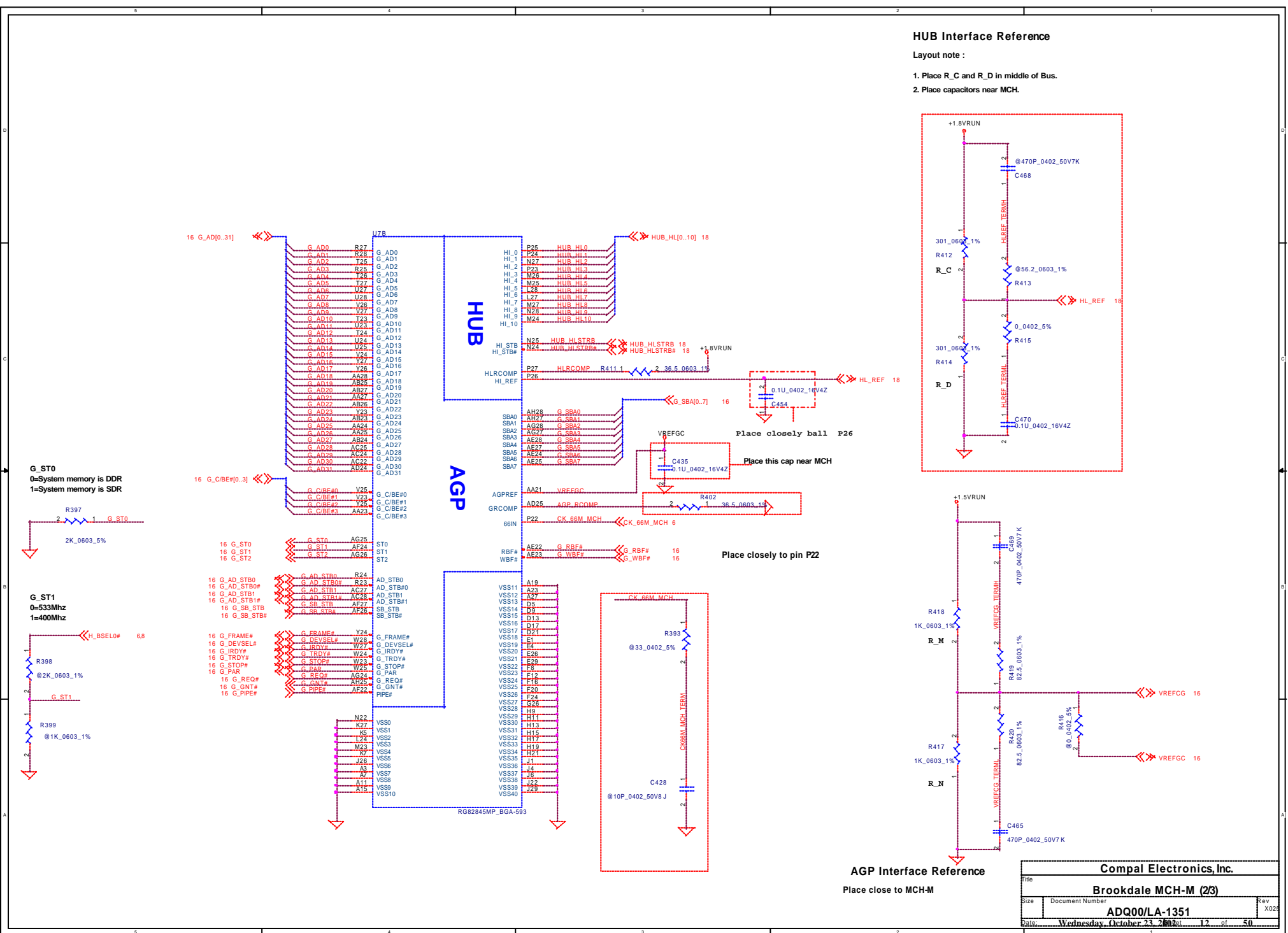
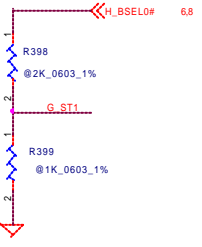

POWER/GND

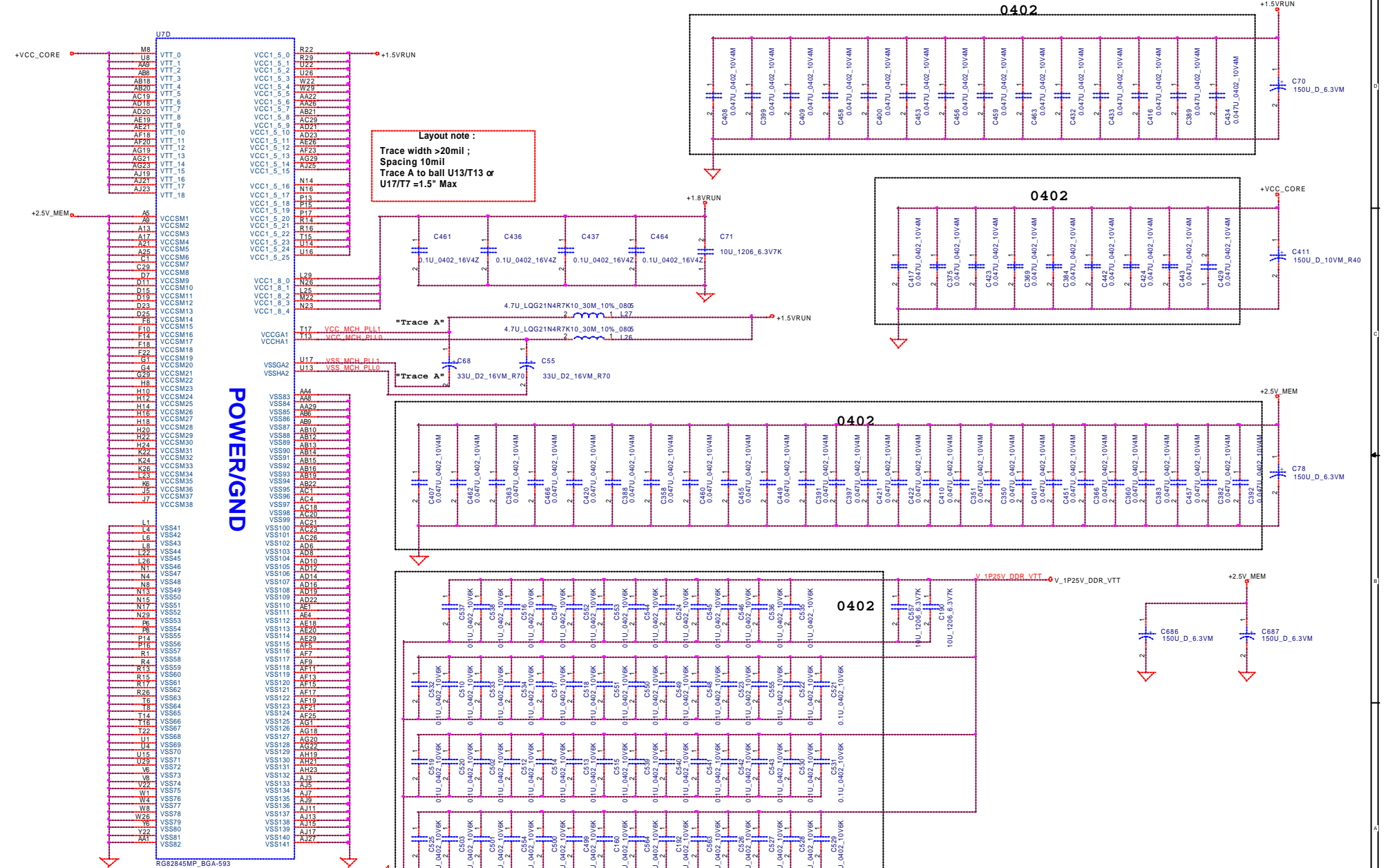

Layout note:
 Trace width >20mil ;
 Spacing 10mil
 Trace A to ball U13/T13 or
 U17/T7 =1.5" Max

Title		Compal Electronics, Inc.	
Size		Brookdale MCH-M (3/3)	
Document Number		ADQ00/LA-1351	
Date	Wednesday, October 23, 2002	Rev	X025
Page		13 of 50	

- 11 DDR_D[0..63]
- 11 DDR_CB[0..7]
- 11 DDR_DS[0..8]

Layout Note:
Place these resistor
closely DIMM0,all
trace length<750 mil

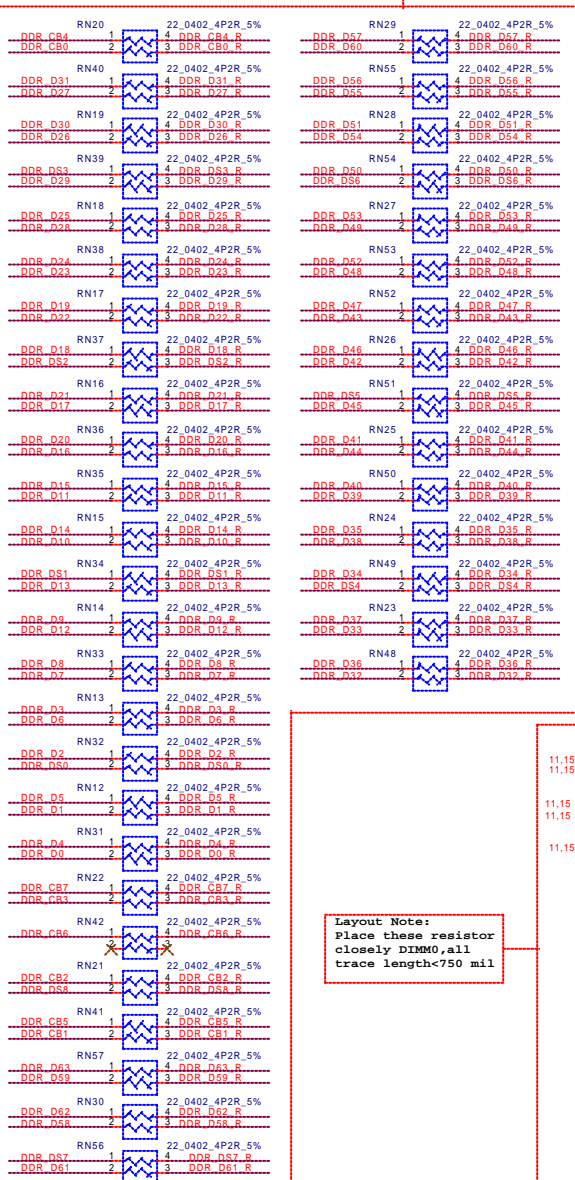

Layout Note:
Place these resistor
closely DIMM0,all
trace length
Max=1.3"

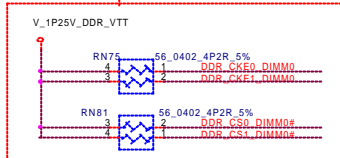

11.15 DDR_MA[0..12]

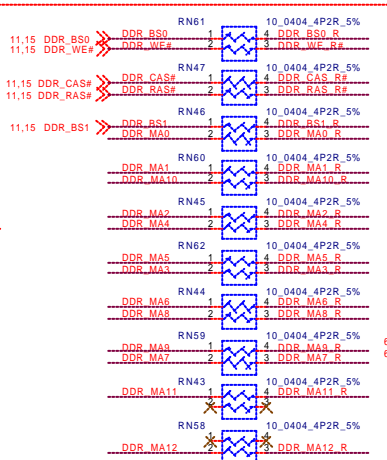

Layout Note:
Place these resistor
closely DIMM0,all
trace length<750 mil

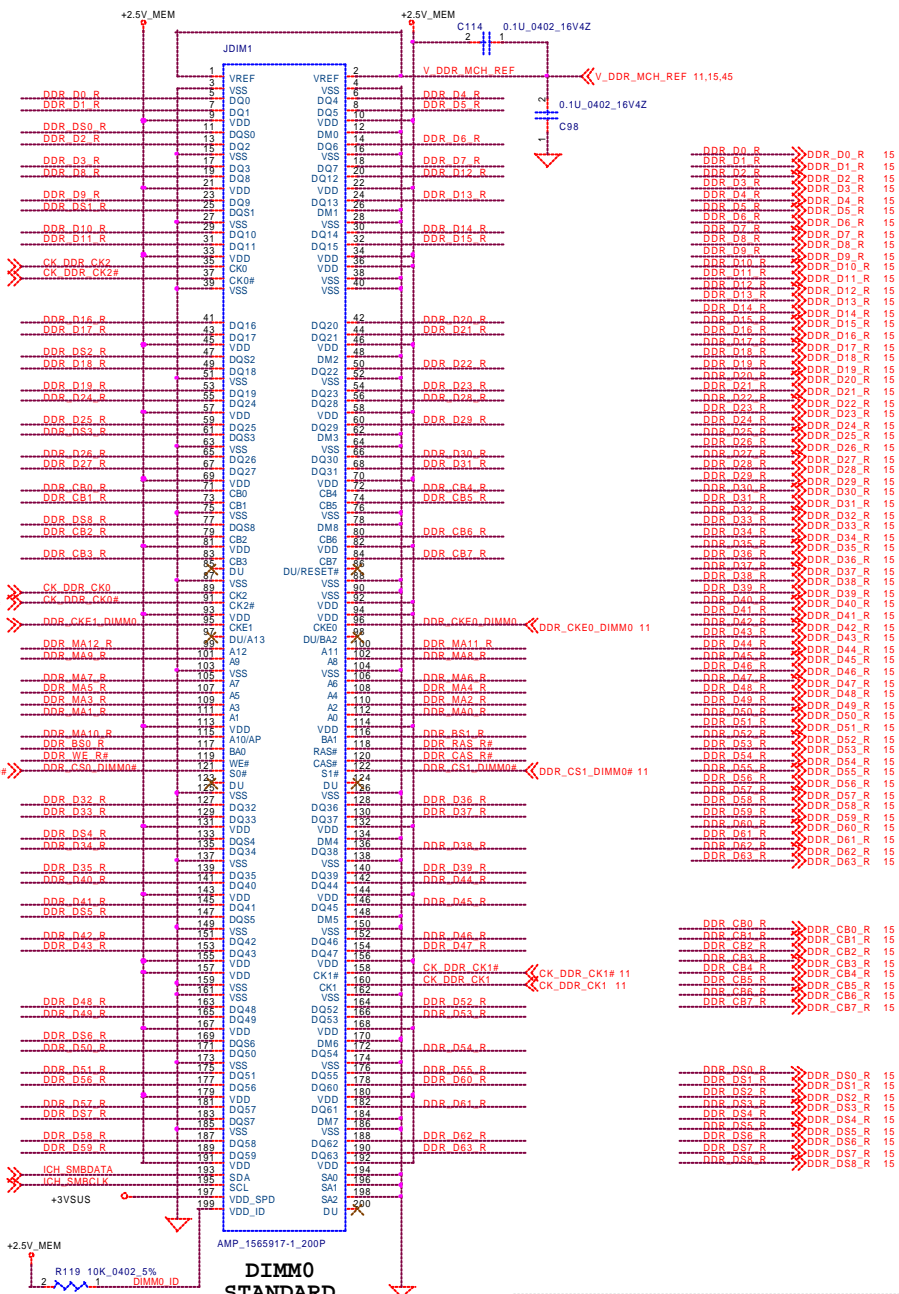

Layout Note:
Place these resistors
closely DIMM1, all
trace length<=800 mll

Layout Note:
Place CAP
near SODIMM
One .1uF cap per power pin.
Place each cap close to
pin.

11,14 DDR_MA0[.12]

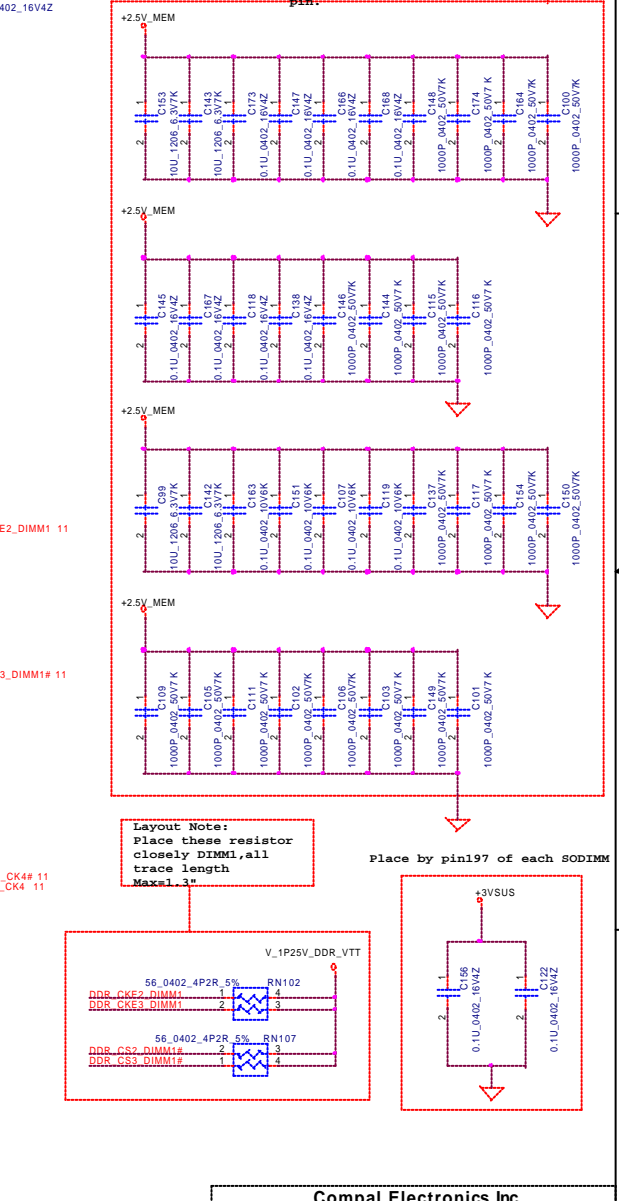
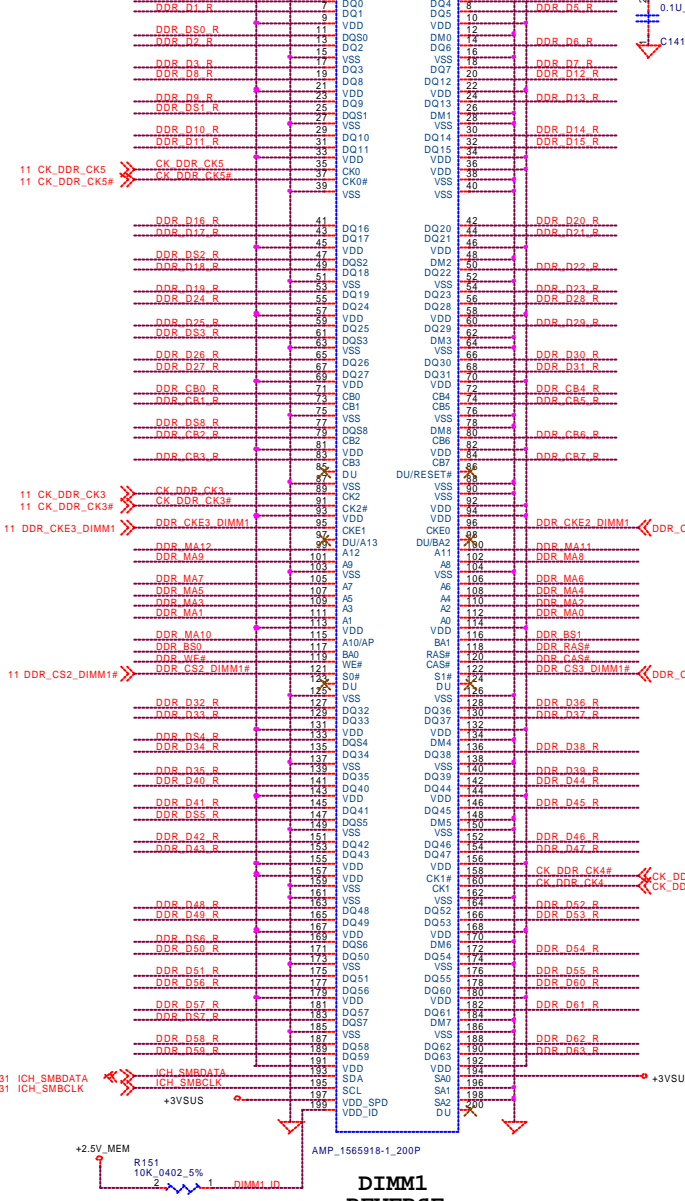
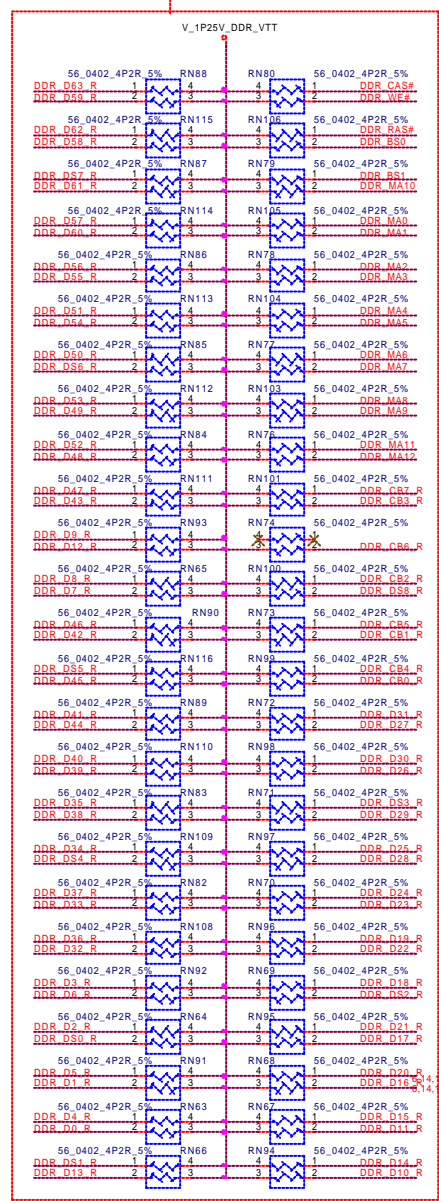

14 DDR_C80_R DDR_C80_R
14 DDR_C81_R DDR_C81_R
14 DDR_C82_R DDR_C82_R
14 DDR_C83_R DDR_C83_R
14 DDR_C84_R DDR_C84_R
14 DDR_C85_R DDR_C85_R
14 DDR_C86_R DDR_C86_R
14 DDR_C87_R DDR_C87_R

14 DDR_D50_R DDR_D50_R
14 DDR_D51_R DDR_D51_R
14 DDR_D52_R DDR_D52_R
14 DDR_D53_R DDR_D53_R
14 DDR_D54_R DDR_D54_R
14 DDR_D55_R DDR_D55_R
14 DDR_D56_R DDR_D56_R
14 DDR_D57_R DDR_D57_R
14 DDR_D58_R DDR_D58_R

11,14 DDR_B50 DDR_B50
11,14 DDR_B51 DDR_B51
11,14 DDR_WE# DDR_WE#
11,14 DDR_CAS# DDR_CAS#
11,14 DDR_RAS# DDR_RAS#

4,9,31 ICH_SMBDATA
4,9,31 ICH_SMBCLK

+2.5V_MEM R151
10K_0402.5% DIMM1_ID

**DIMM1
REVERSE**

Layout Note:
Place these resistor
closely DIMM1, all
trace length
Max<1.3"

Place by pin197 of each SODIMM

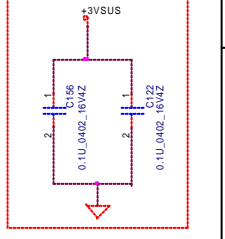
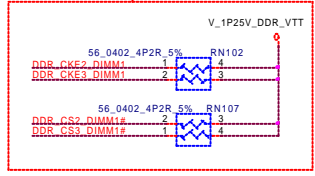

Compal Electronics, Inc.

DDR-SODIMM SLOT2

ADQ00/LA-1351

Date: Wednesday, October 23, 2002 15 of 50

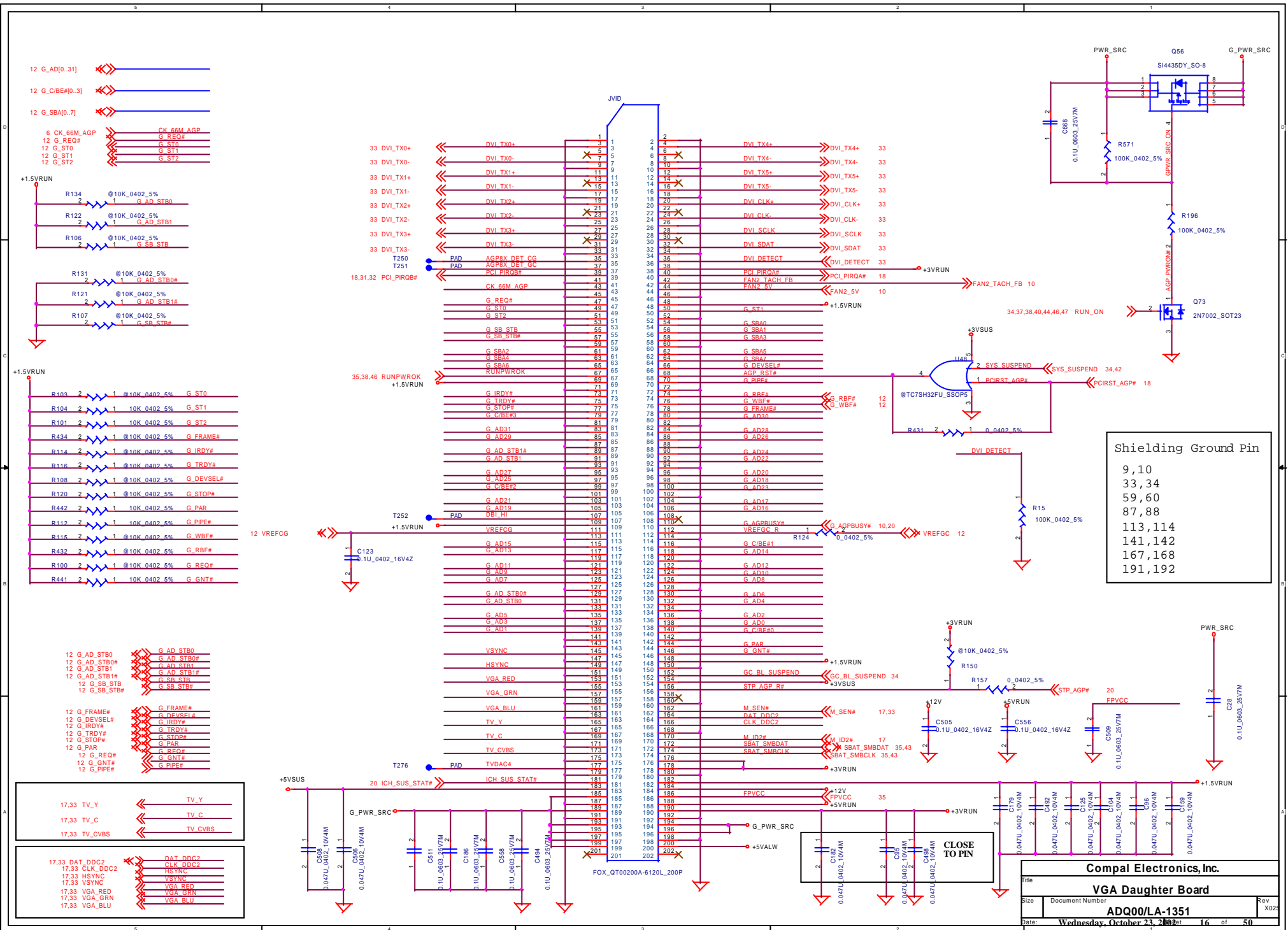

Shielding Ground Pin

9,10
33,34
59,60
87,88
113,114
141,142
167,168
191,192

Compal Electronics, Inc.

VGA Daughter Board

ADQ00/LA-1351

Date: Wednesday, October 23, 2002 16 of 50

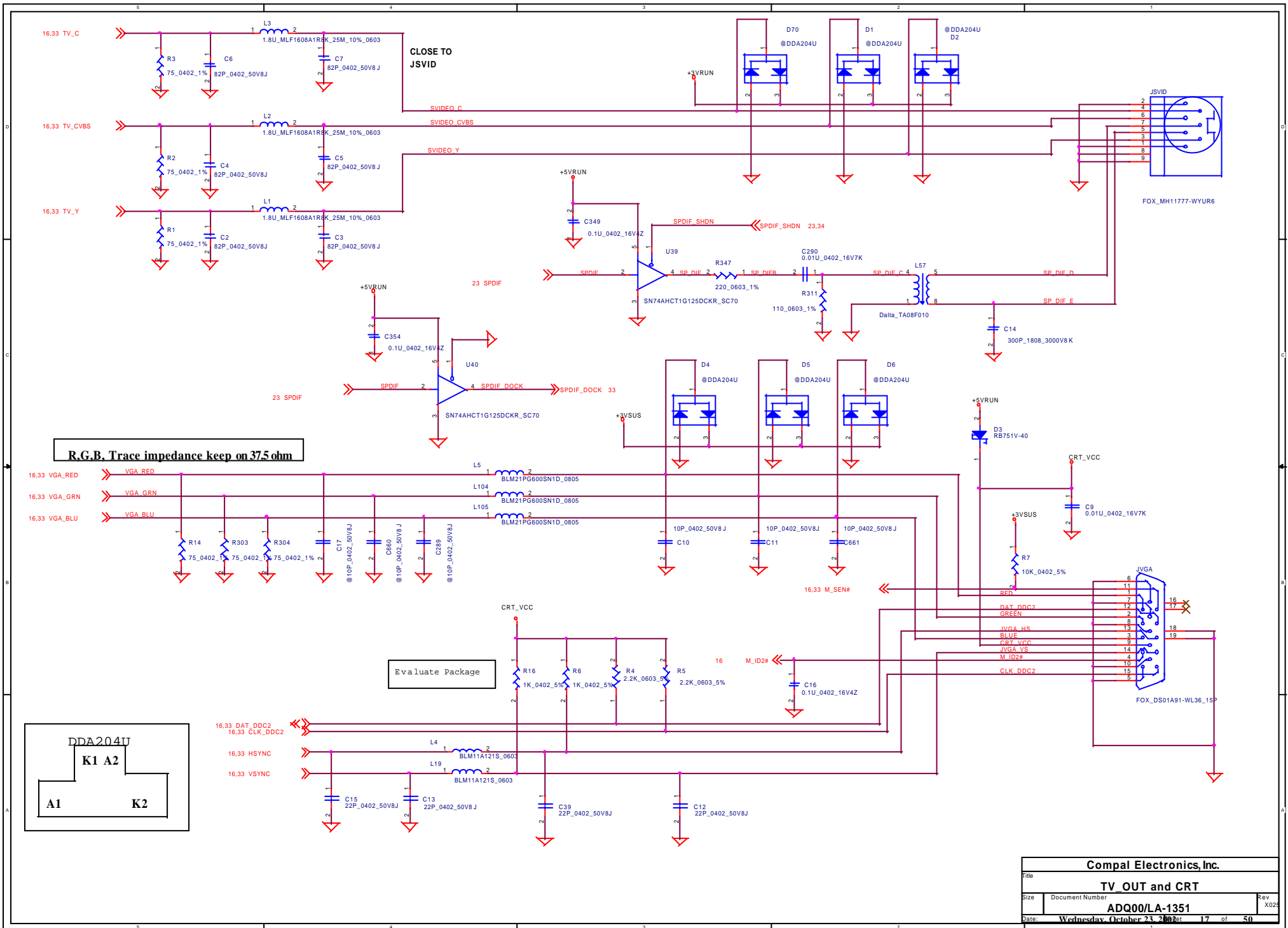

R.G.B. Trace impedance keep on 37.5 ohm

Evaluate Package

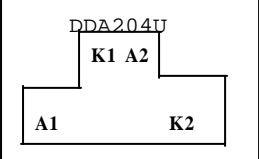

Compal Electronics, Inc.		
TV_OUT and CRT		
Size	Document Number	Rev
	ADQ00/LA-1351	X025
Date:	Wednesday, October 23, 2008	17 of 50

Hub interface Layout:
 Route signal with 5/15
 trace/space, < 8 inches
 Signal must match +/- 0.1" of HL_STB/STB# signals.

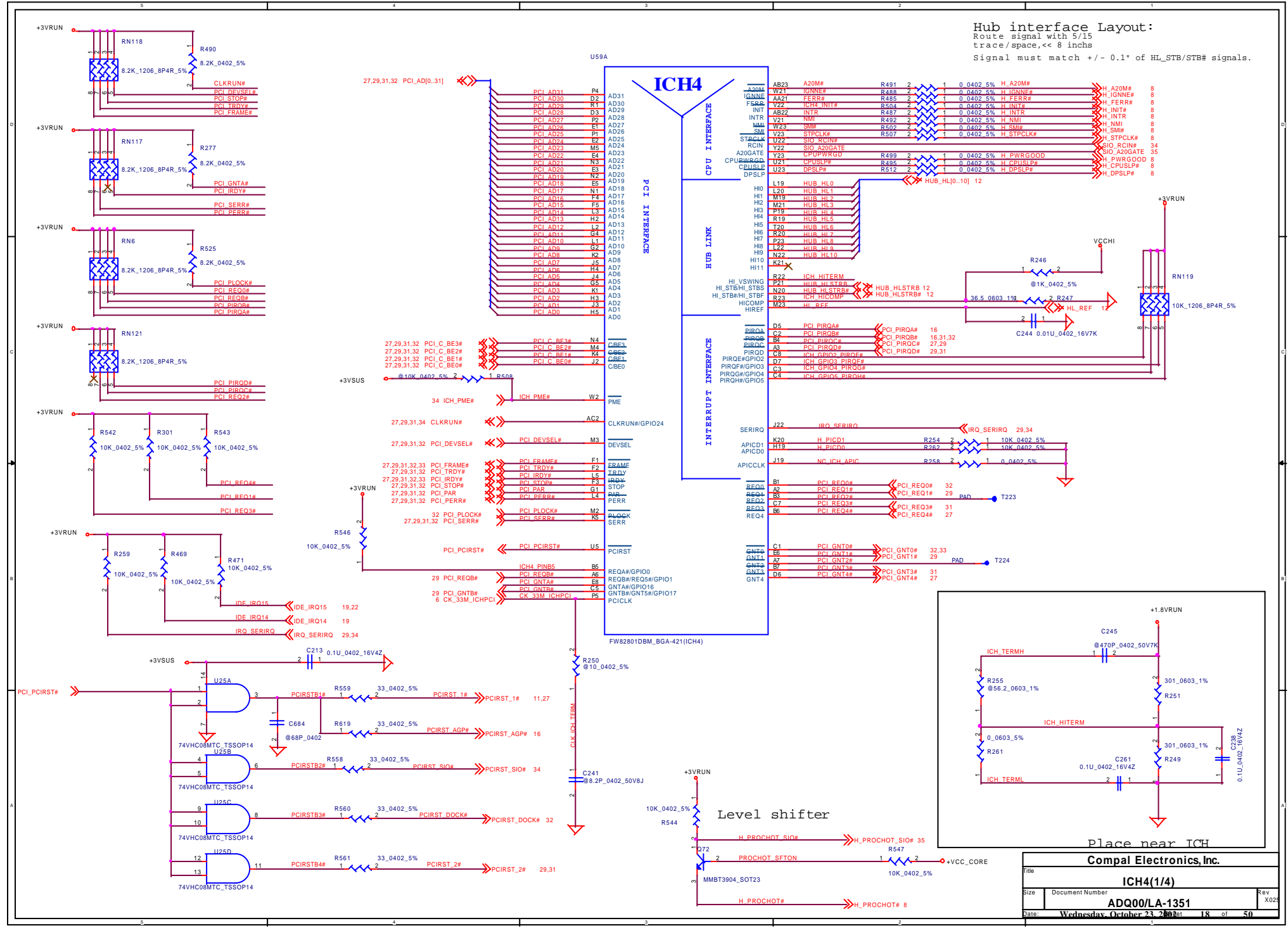

Title		ICH4(1/4)	
Size	Document Number	Rev X025	
ADQ00/LA-1351			
Date	Wednesday, October 23, 2002		18 of 50

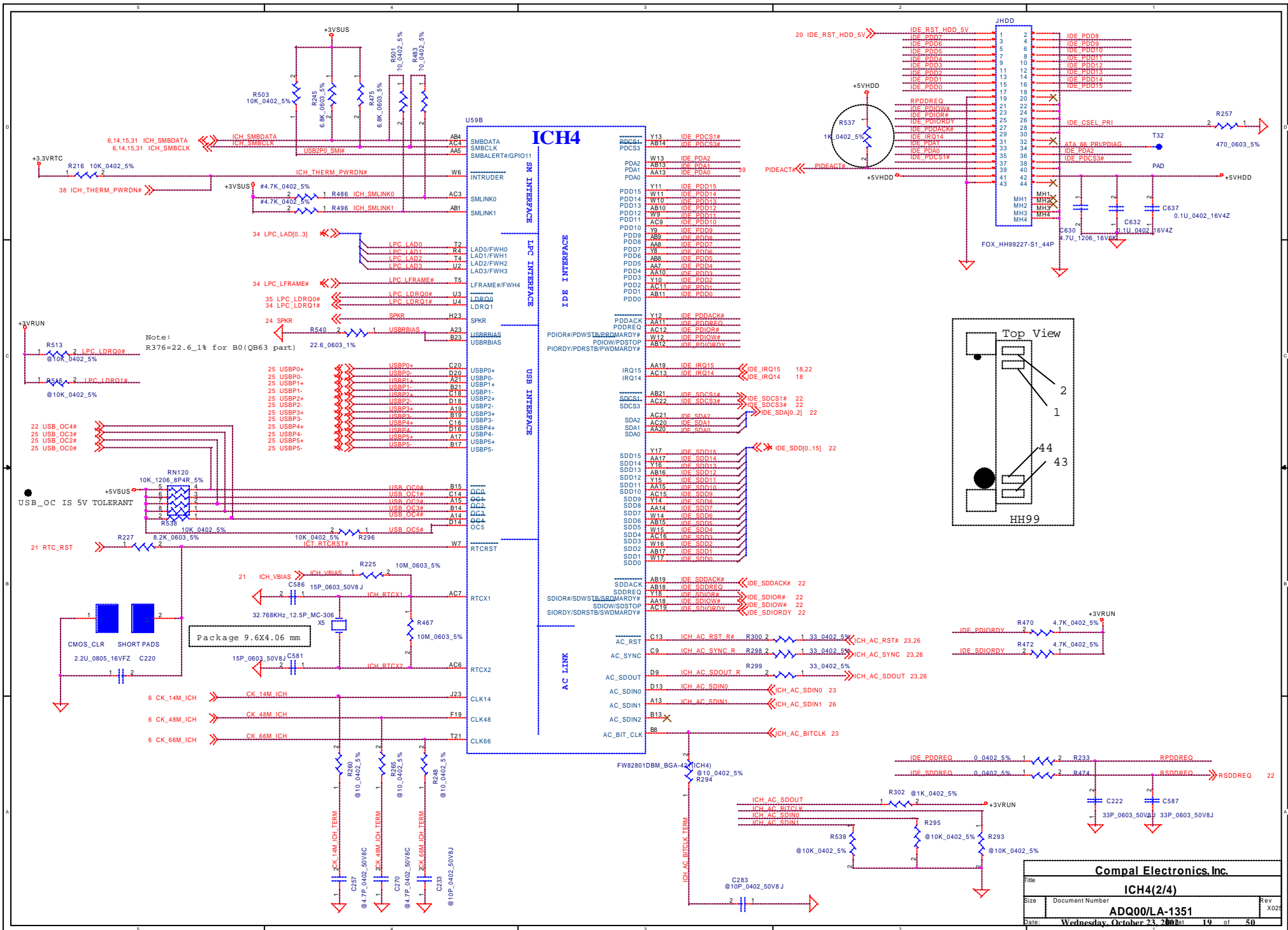

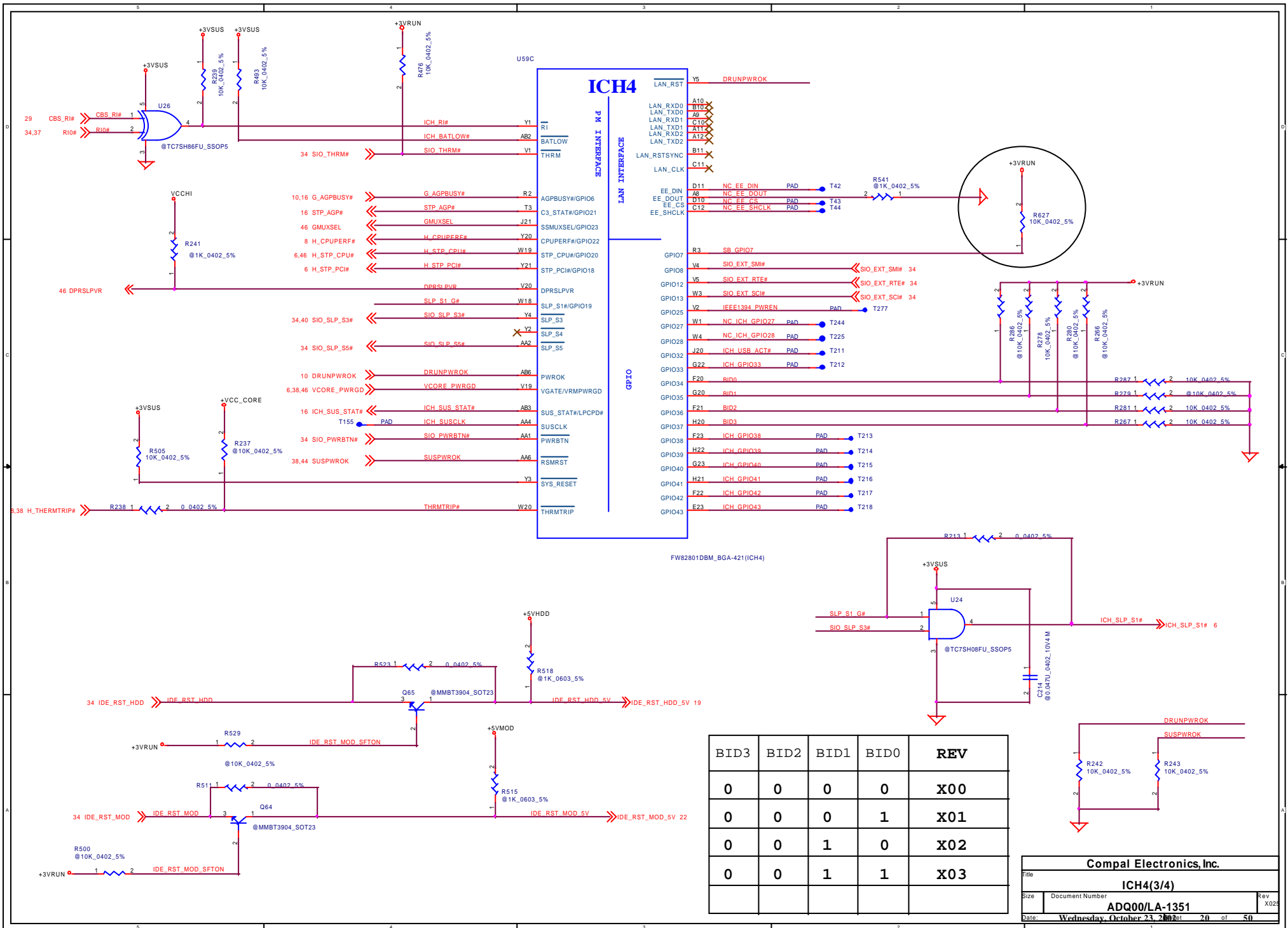

BID3	BID2	BID1	BID0	REV
0	0	0	0	X00
0	0	0	1	X01
0	0	1	0	X02
0	0	1	1	X03

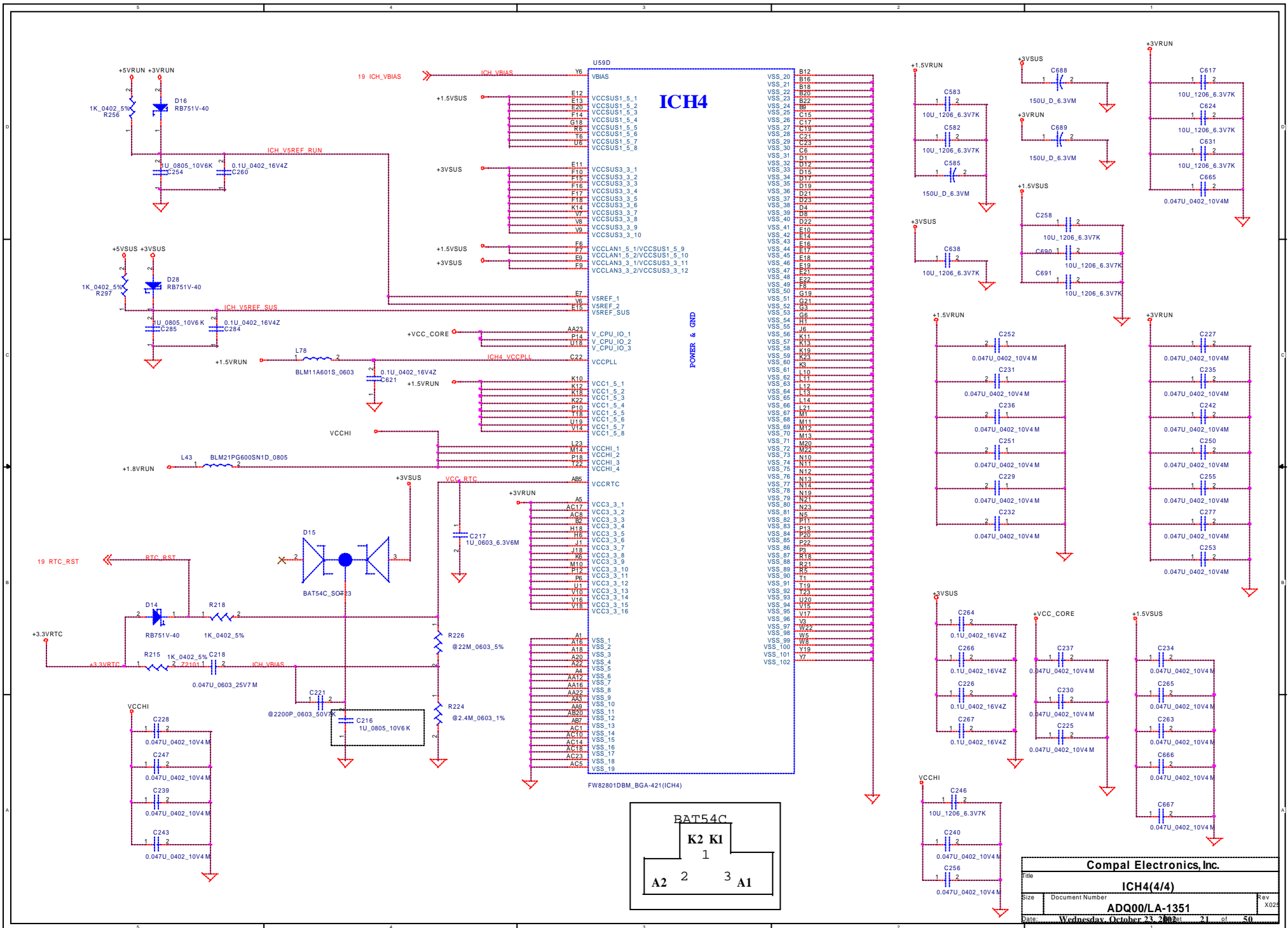

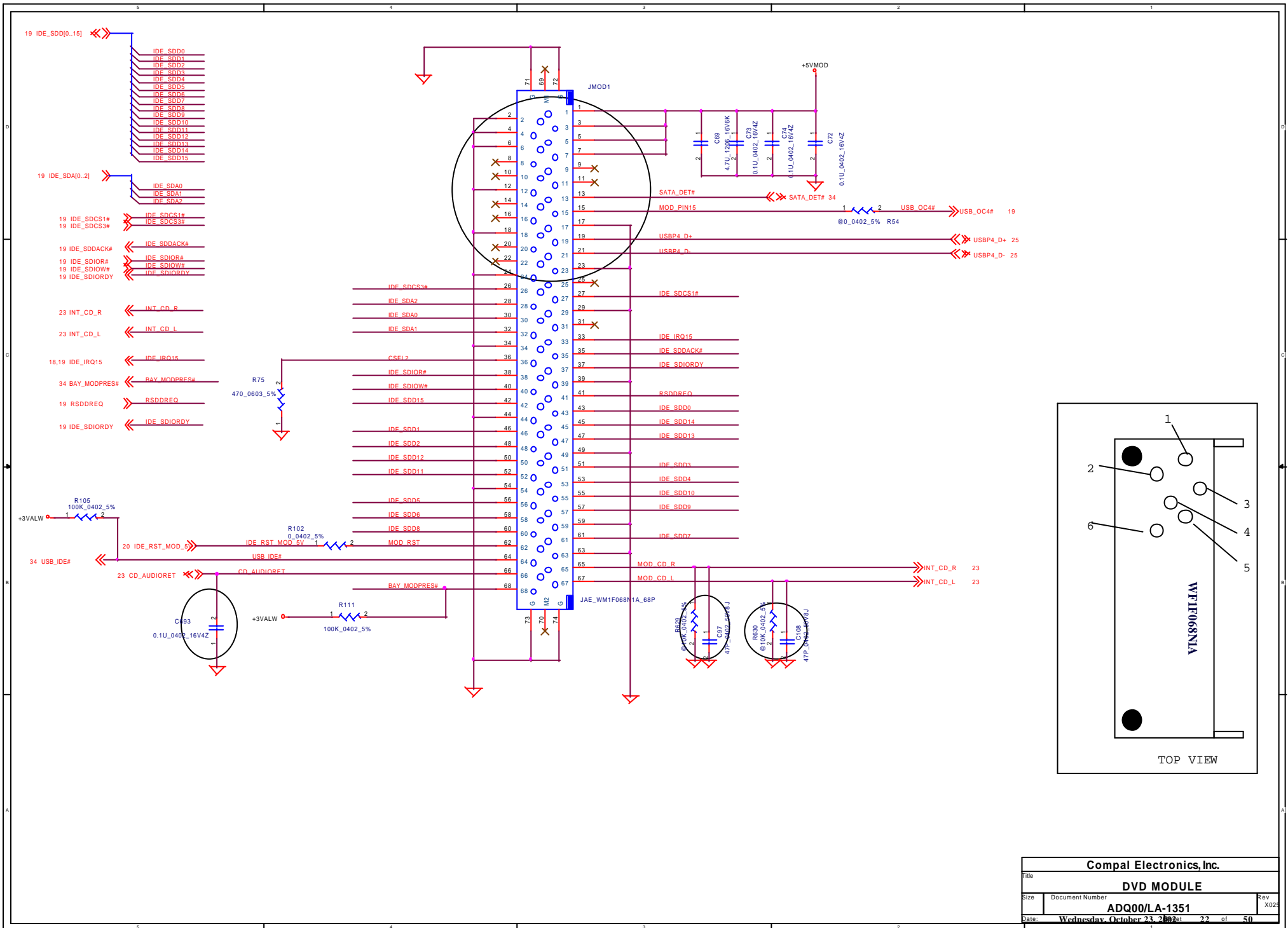

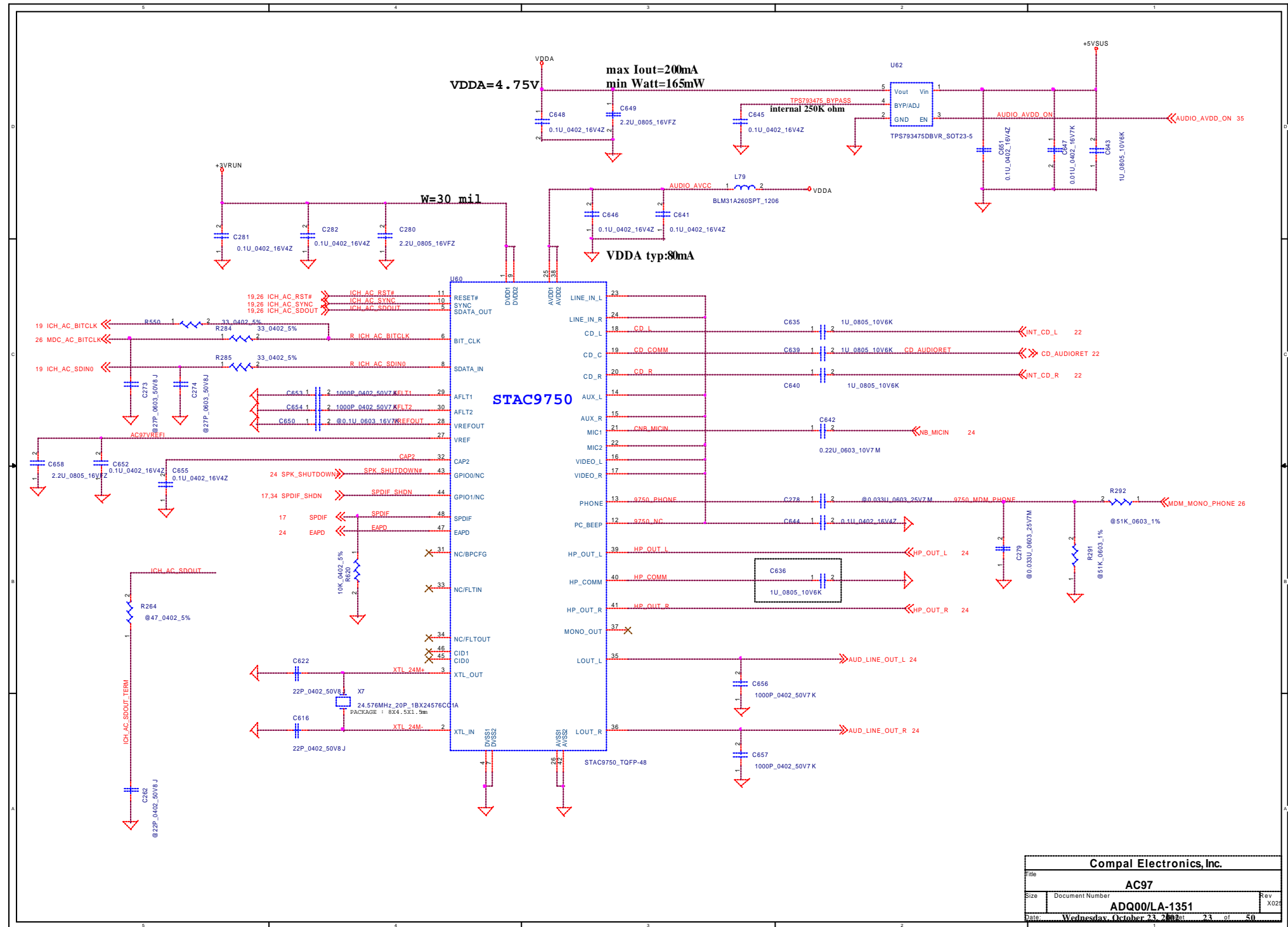

Compal Electronics, Inc.		
AC97		
Size	Document Number	Rev
	ADQ00/LA-1351	X025
Date	Wednesday, October 23, 2002	23 of 50

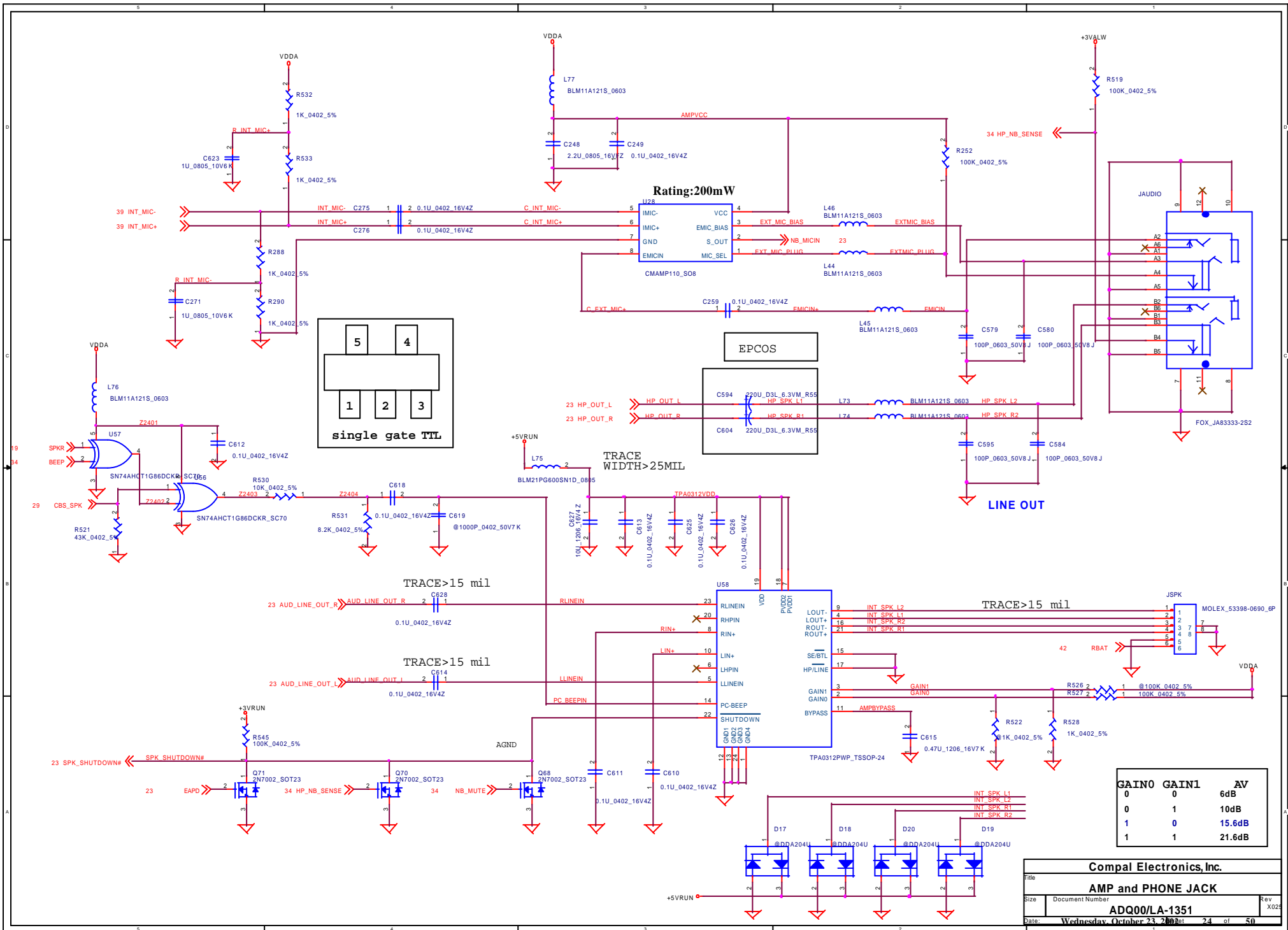

Rating:200mW

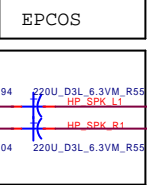
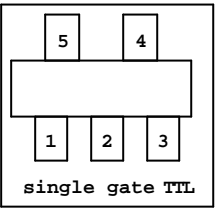

TRACE WIDTH > 25MIL

TRACE > 15 mil

TRACE > 15 mil

TRACE > 15 mil

GAIN	GAIN1	AV
0	0	6dB
0	1	10dB
1	0	15.6dB
1	1	21.6dB

Compal Electronics, Inc.

AMP and PHONE JACK

ADQ00/LA-1351

Title: _____
 Size: _____ Document Number: _____ Rev: X025
 Date: Wednesday, October 23, 2008 24 of 50

USB PORT#	DESTINATION
0	BACK
1	BT
2	BACK
3	DOG
4	MOD
5	DOCK

PLACE CHOKE
NEAR
CONNECTOR

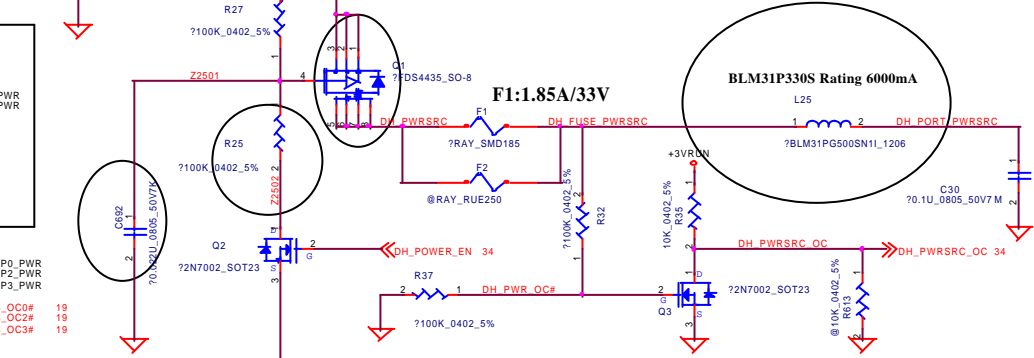
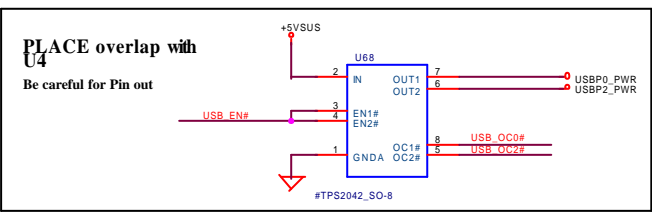
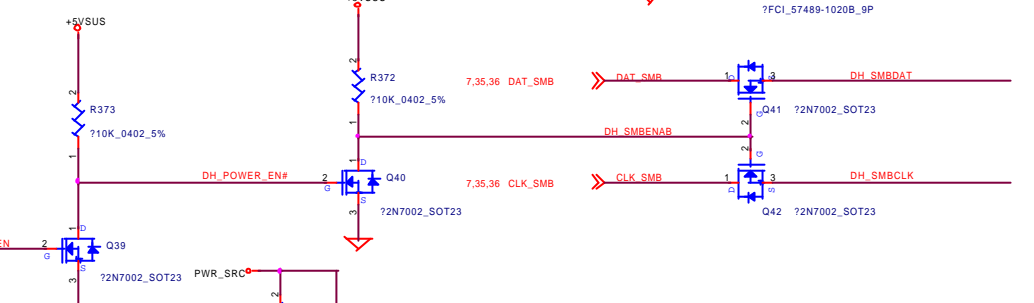
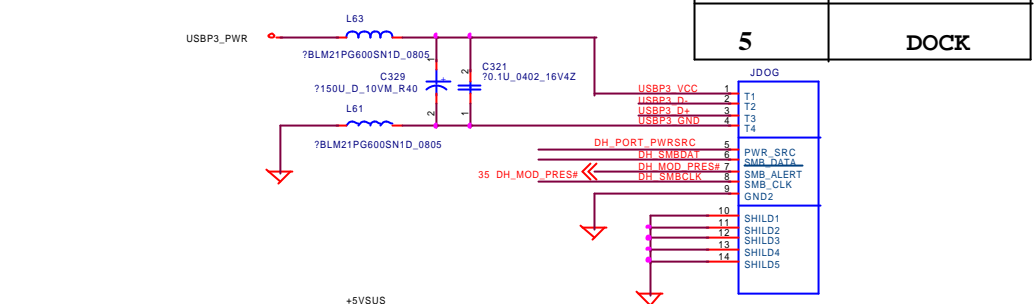
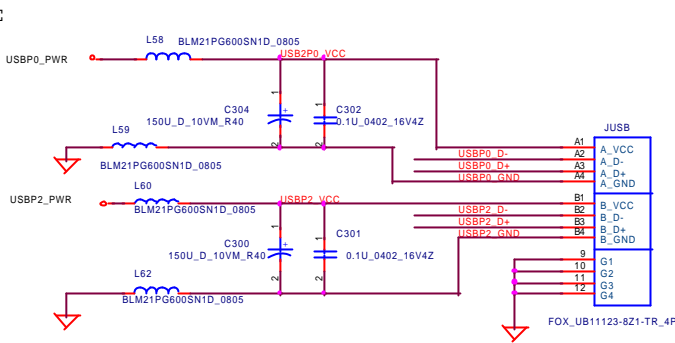
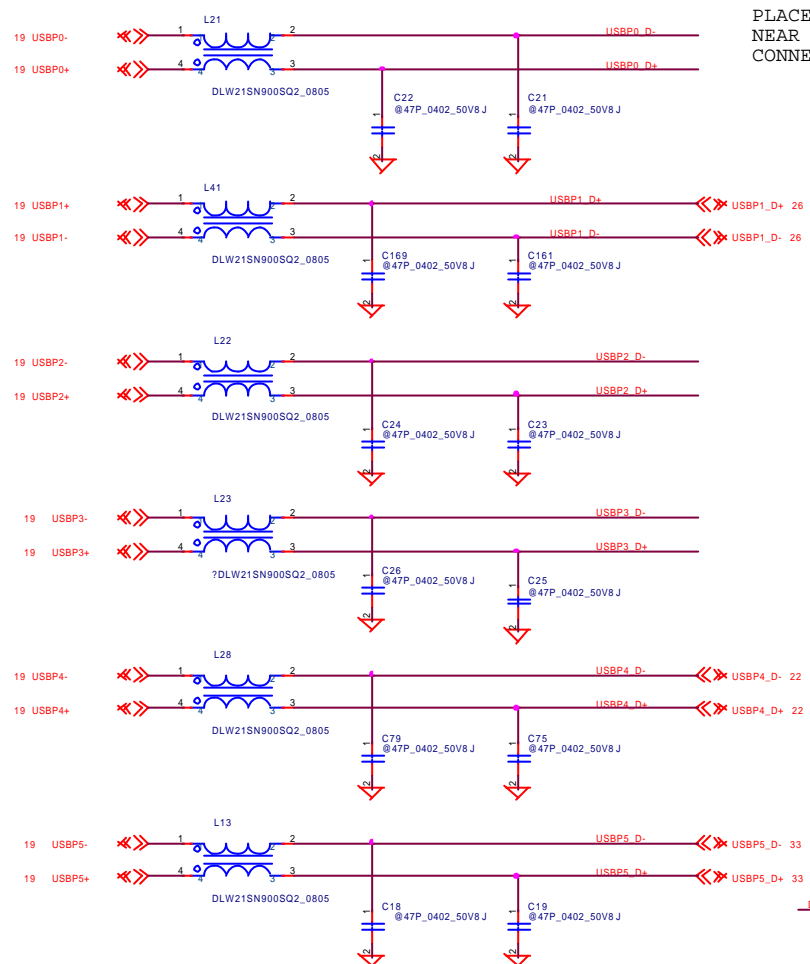

Compal Electronics, Inc.

USB/Doghouse

ADQ00/LA-1351

Wednesday, October 23, 2002 25 of 50

TOP view

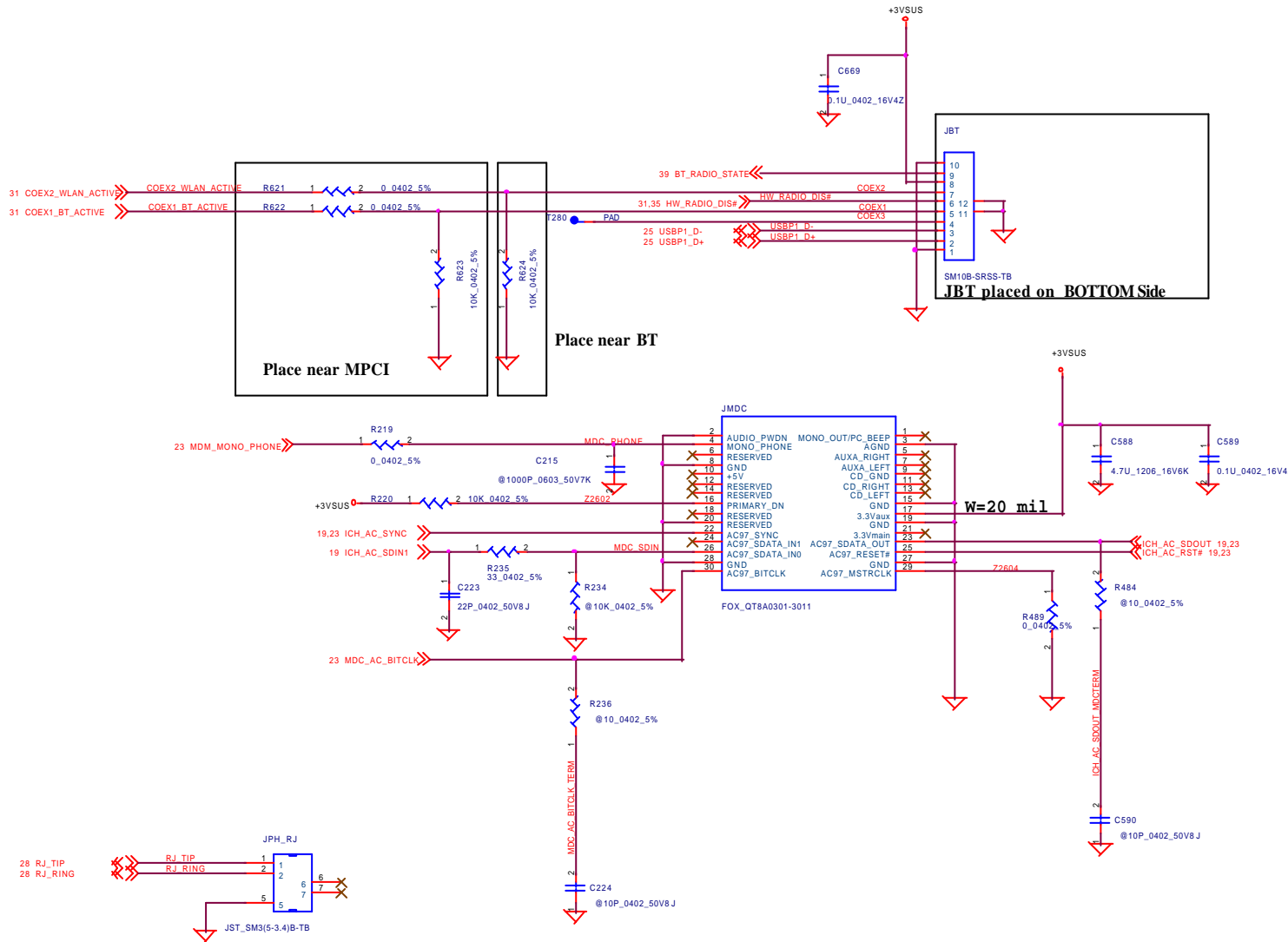
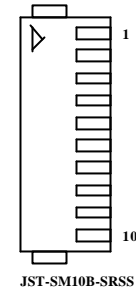

Compal Electronics, Inc.		
Title		
BT PORT and MDC		
Size	Document Number	Rev
	ADQ00/LA-1351	X025
Date	Wednesday, October 23, 2008	26 of 50

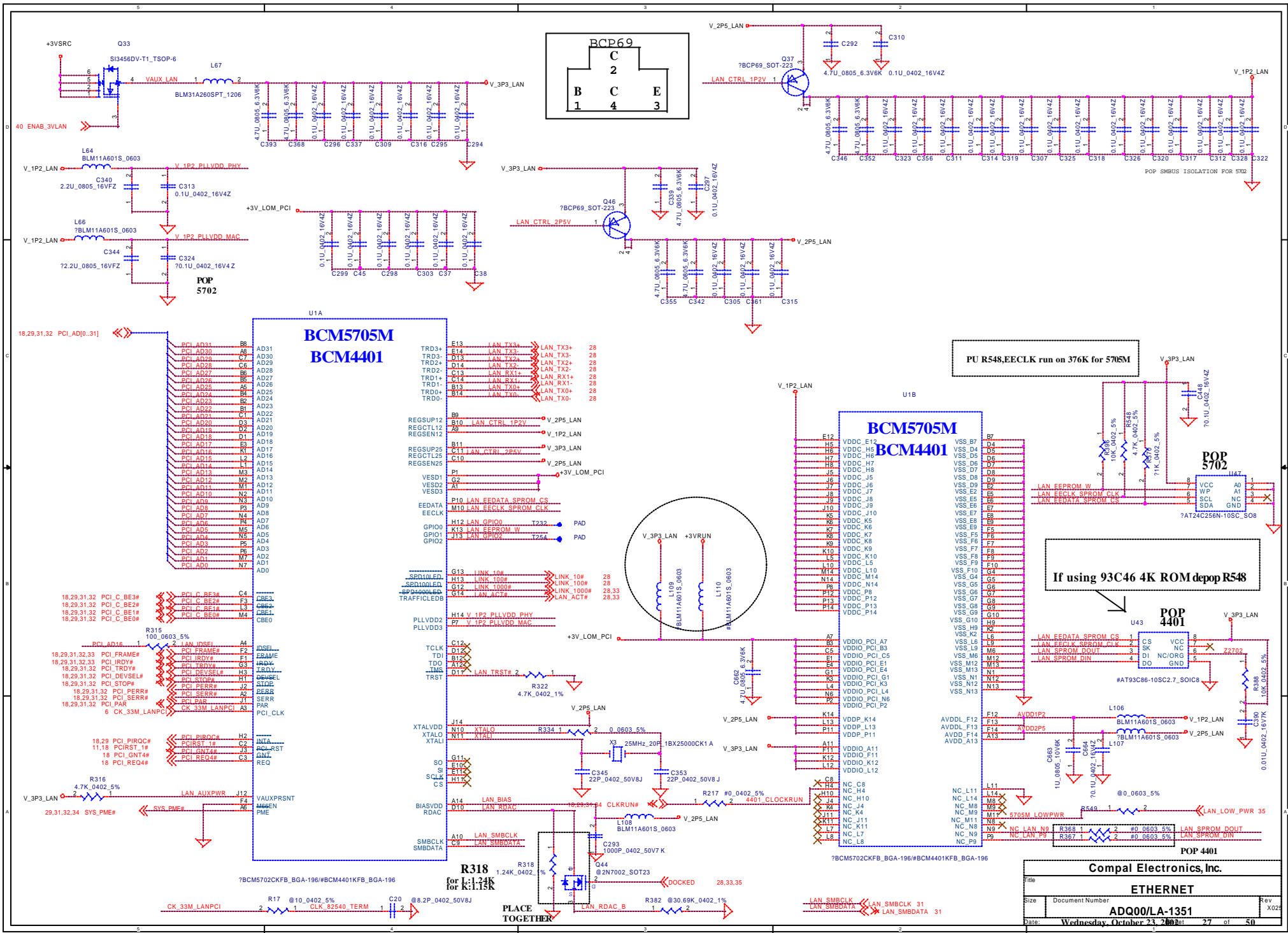

PU R548,EECLK run on 376K for 5705M

If using 93C46 4K ROM depop R548

POP 4401

Compal Electronics, Inc.		
ETHERNET		
Size	Document Number	Rev
	ADQ00/LA-1351	X02
Date	Wednesday, October 23, 2002	27 of 50

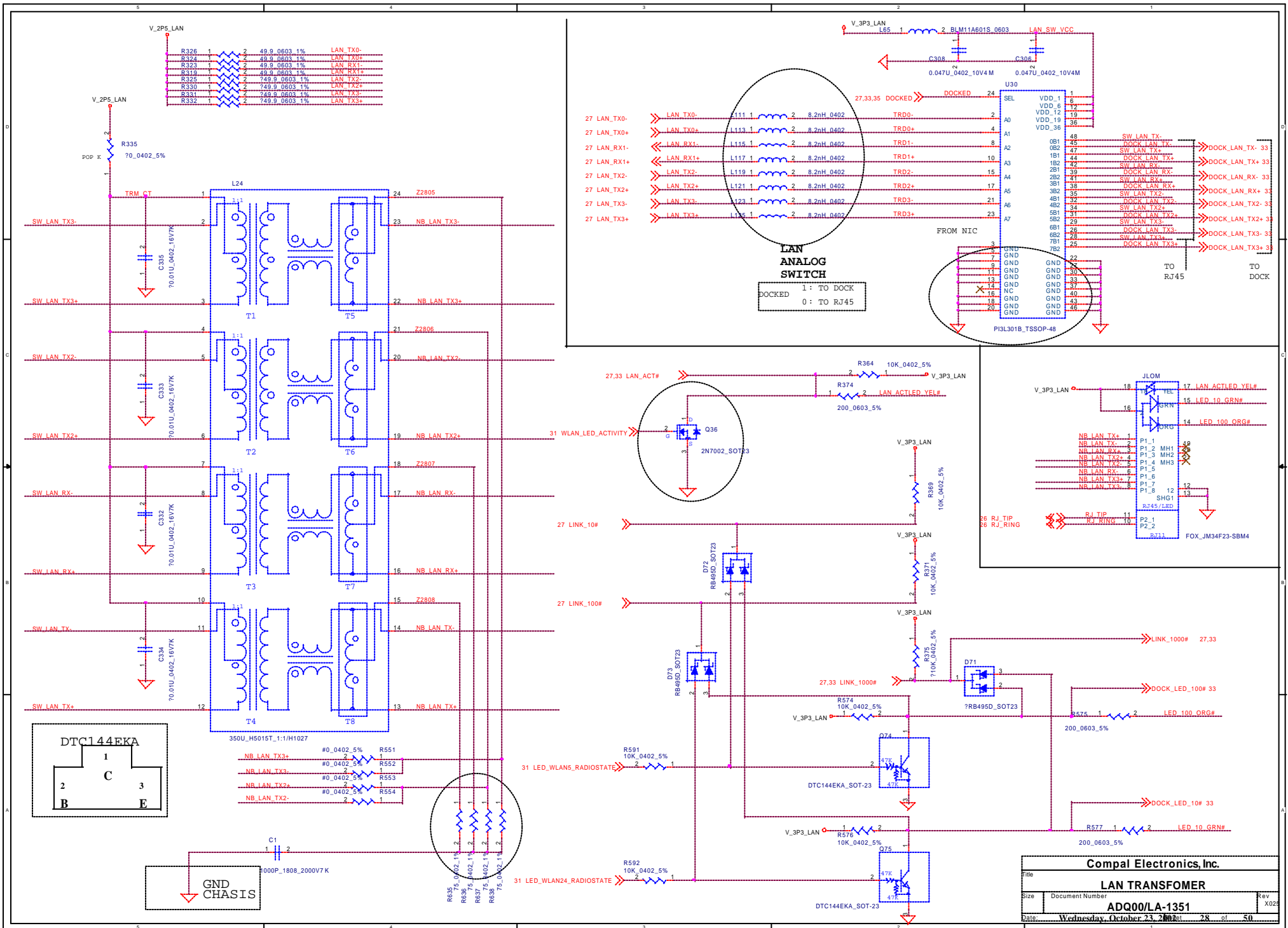

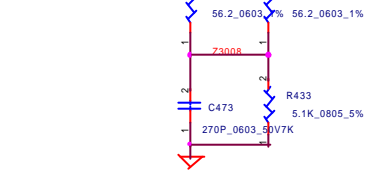
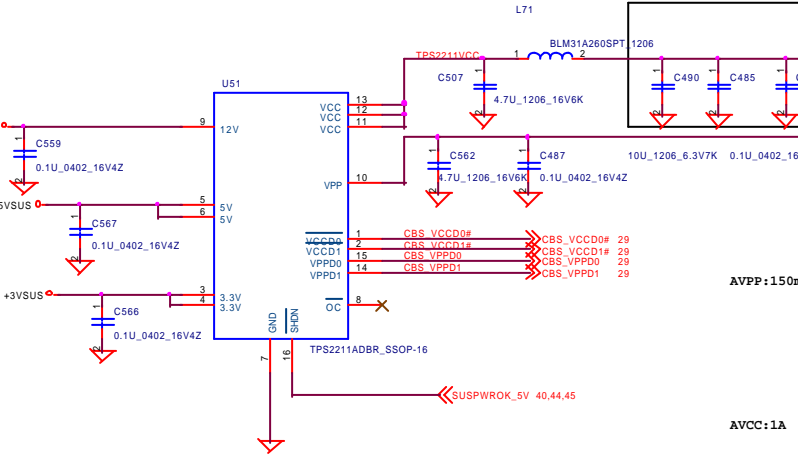
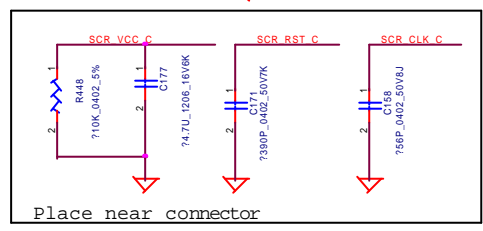
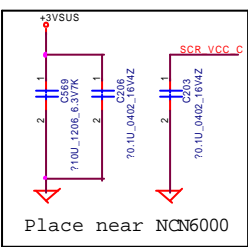
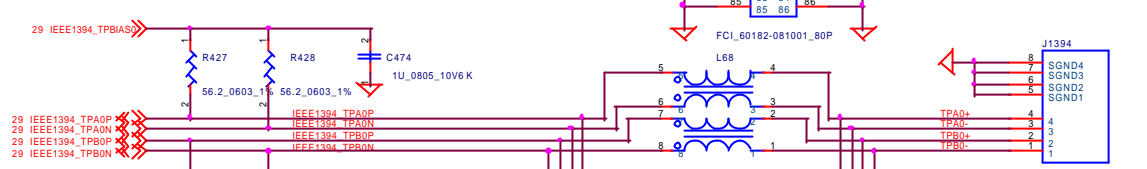
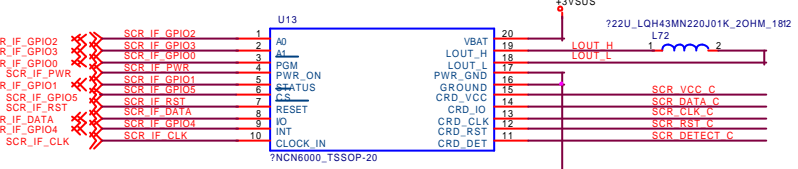
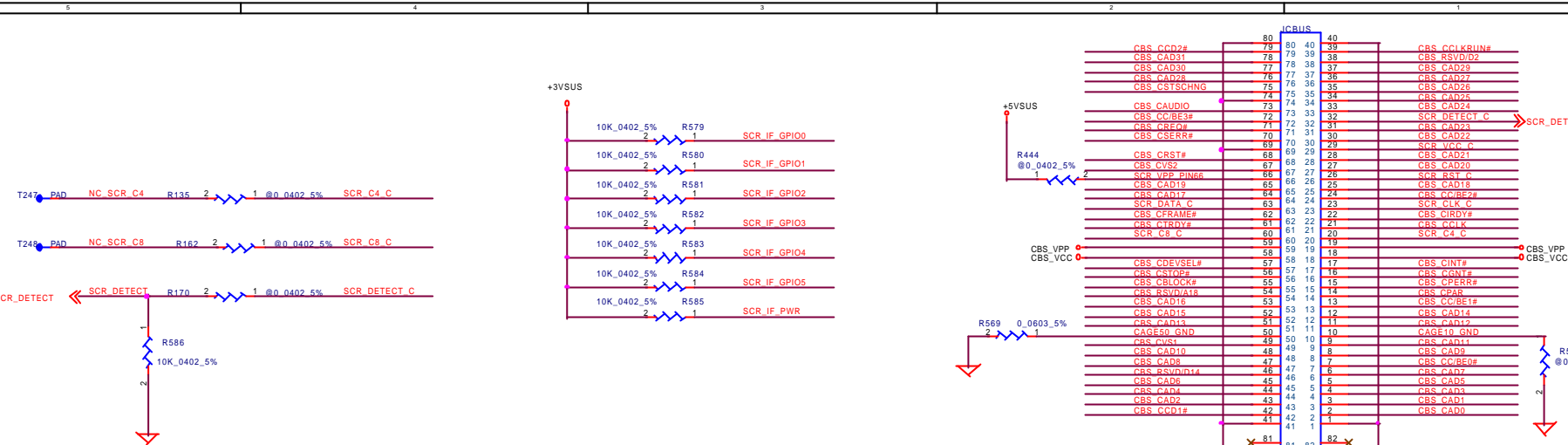

SHDN#	VPPD1	VPPD0	CBS_VPP
1	0	0	0V
1	0	1	CBS_VCC
1	1	0	12V
1	1	1	Hi-Z
0	X	X	Hi-Z

SHDN#	VCCD1#	VCCD0#	CBS_VCC
1	0	0	0V
1	0	1	3.3V
1	1	0	5V
1	1	1	0V
0	X	X	Hi-Z

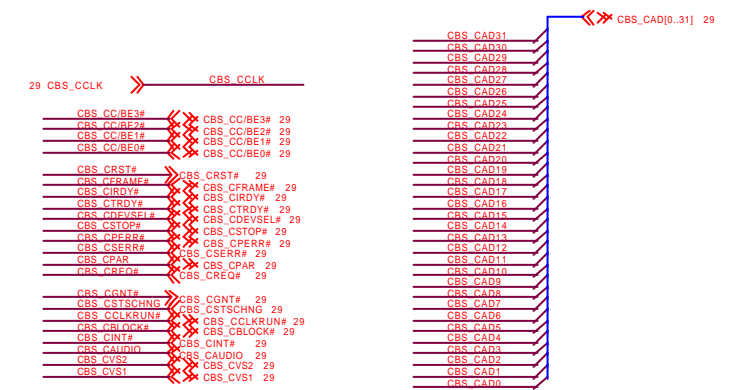
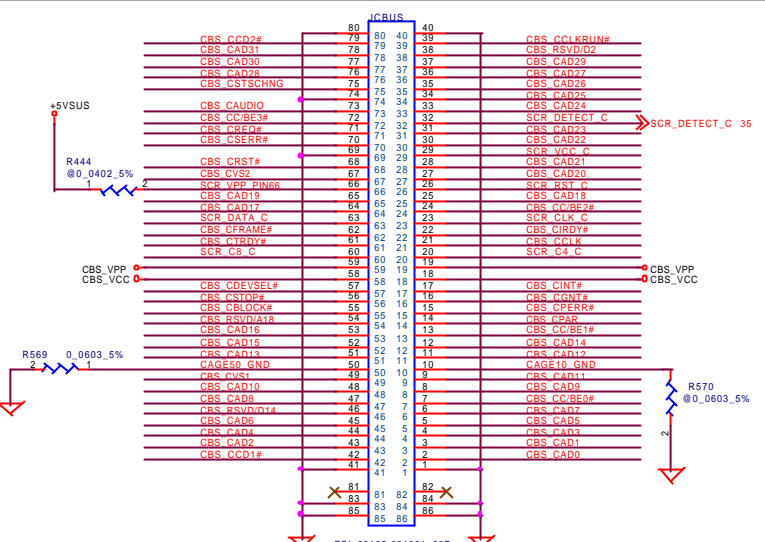

Compal Electronics, Inc.

CardBus Socket

ADQ00/LA-1351

File: _____
 Size: _____ Document Number: _____ Rev: X025
 Date: Wednesday, October 23, 2002 30 of 50

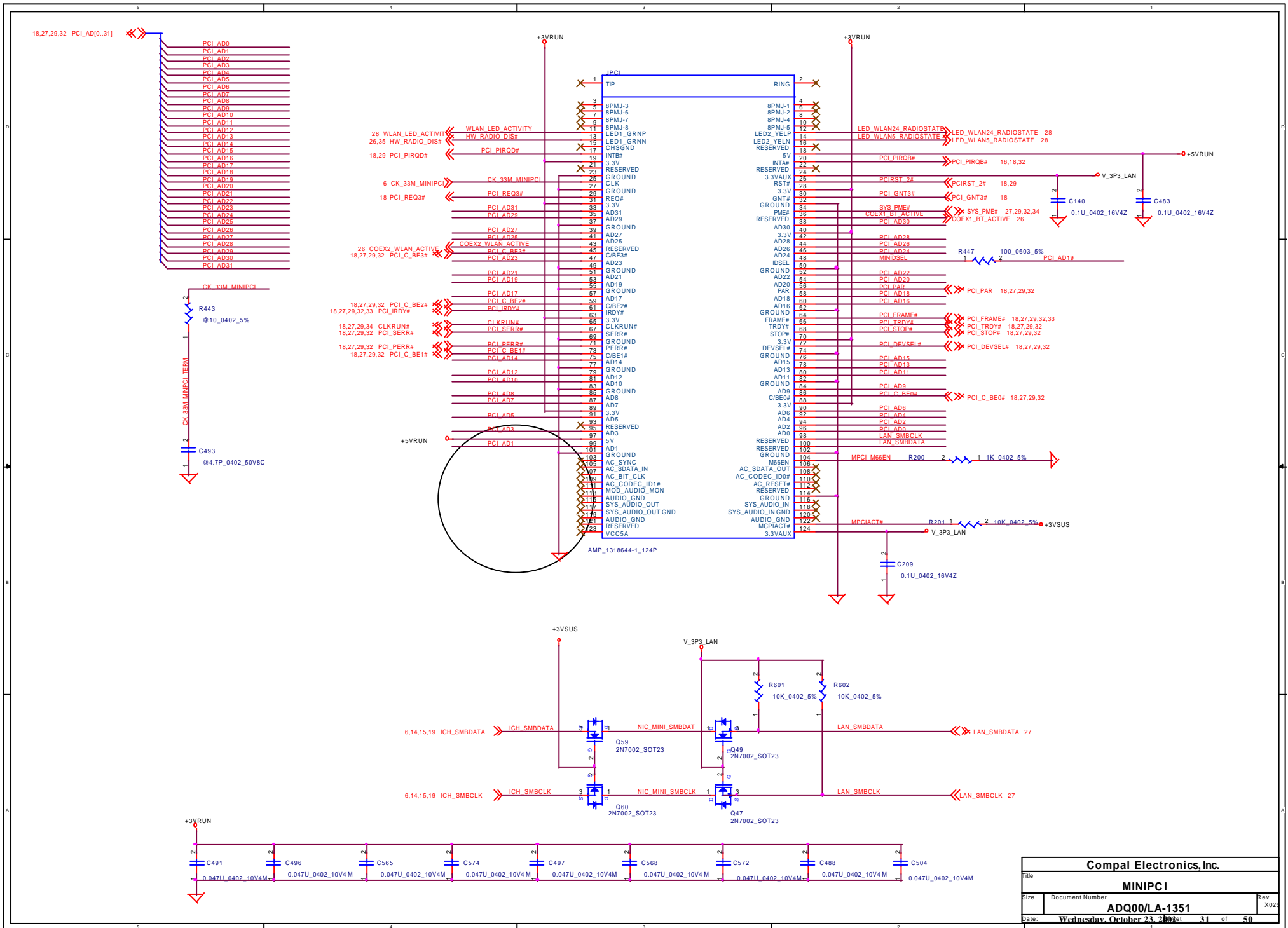

Compal Electronics, Inc.		
MINIPCI		
Size	Document Number	Rev
	ADQ00/LA-1351	X025
Date:	Wednesday, October 23, 2008	31 of 50

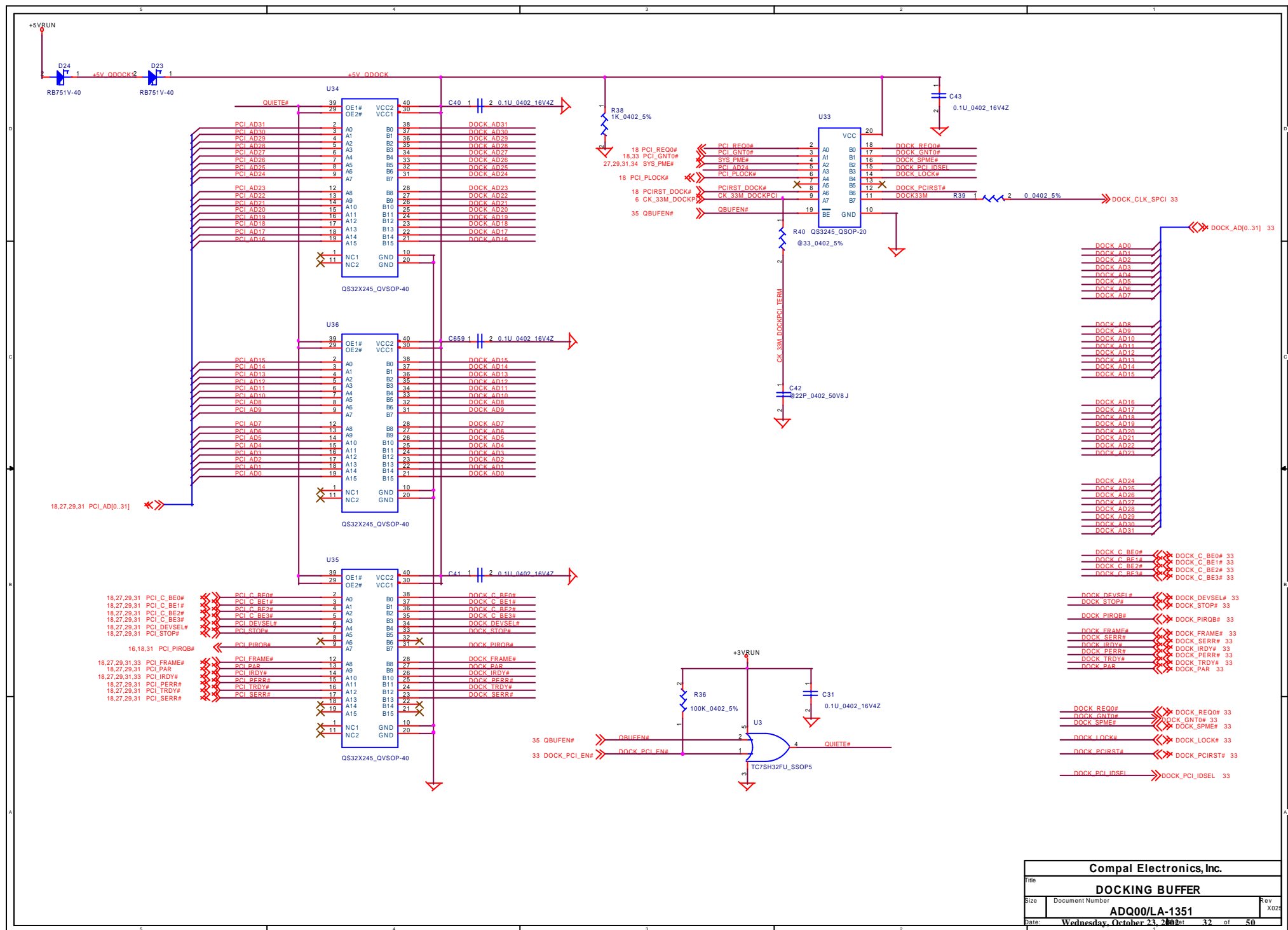

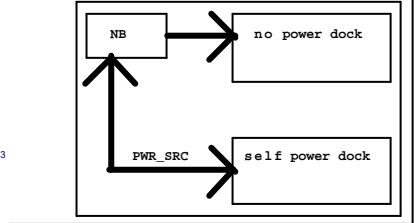
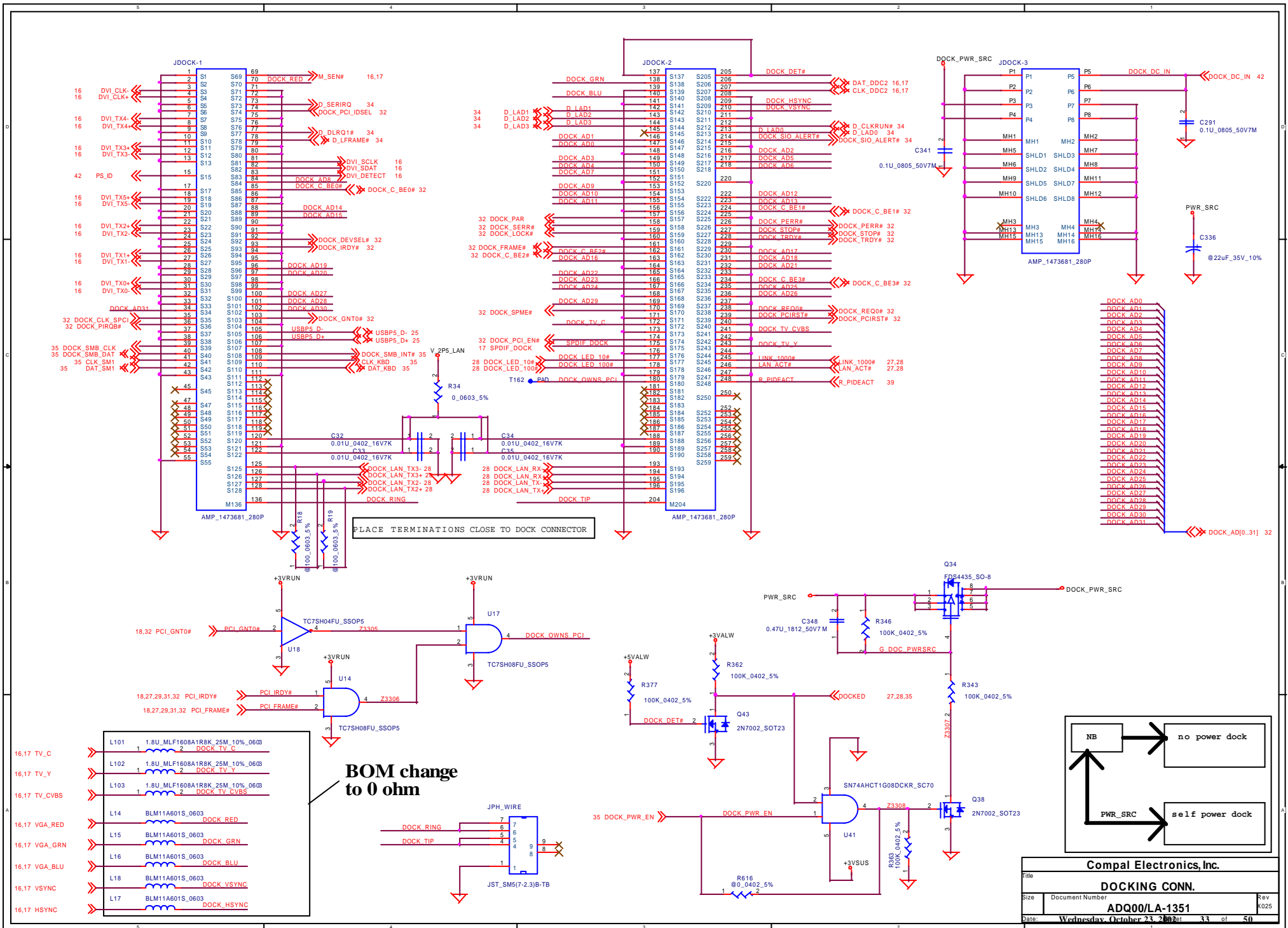

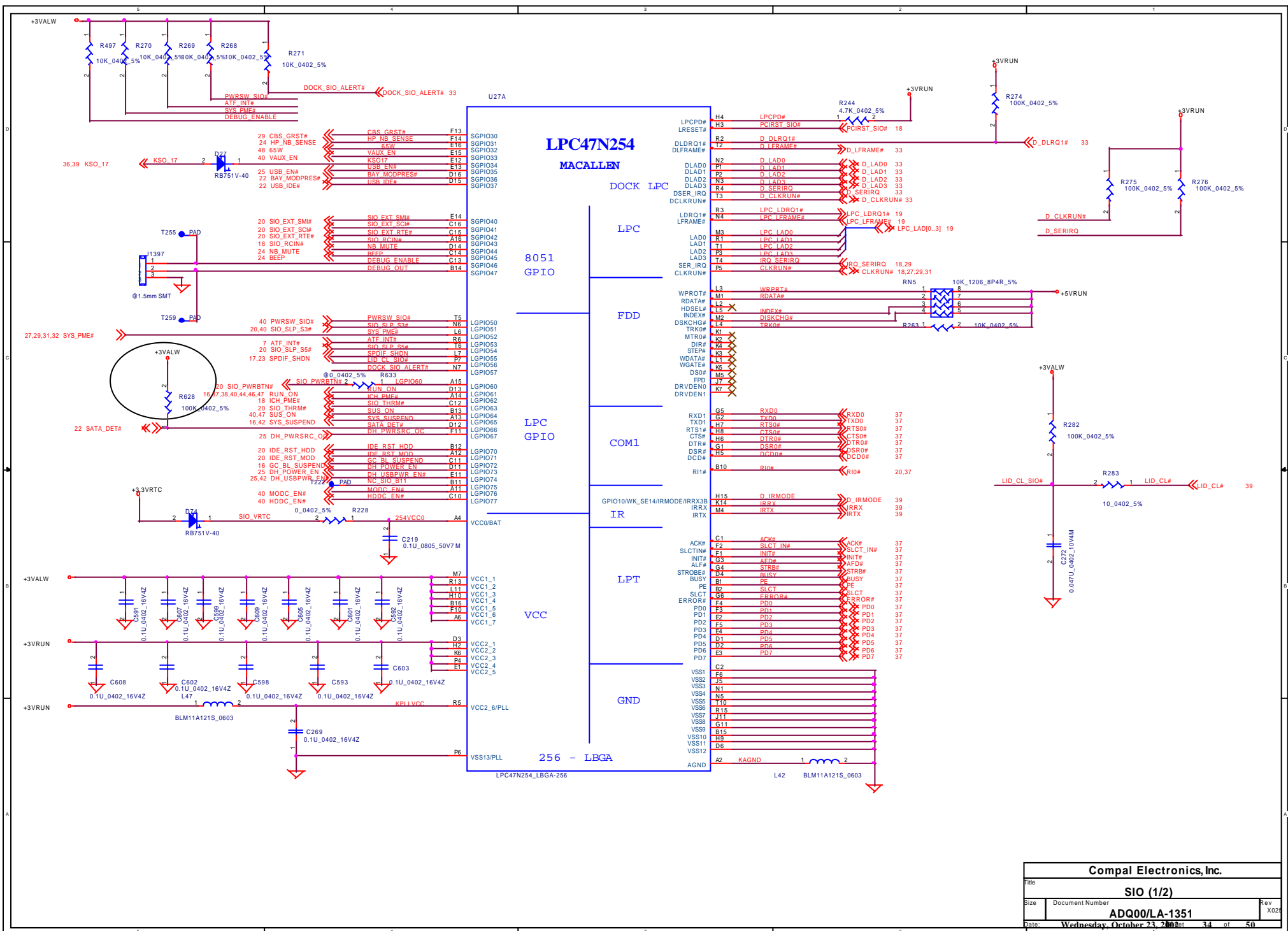

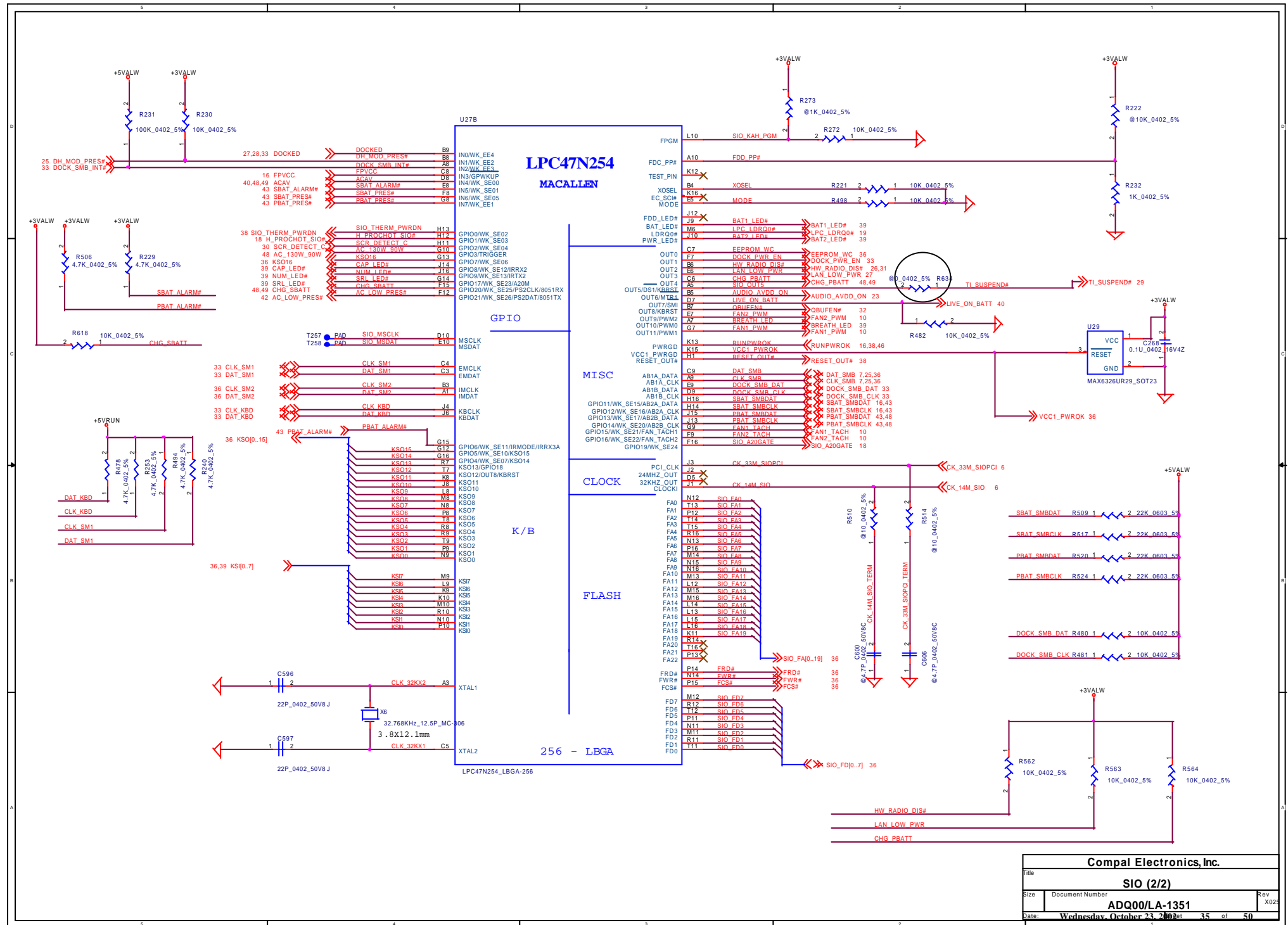

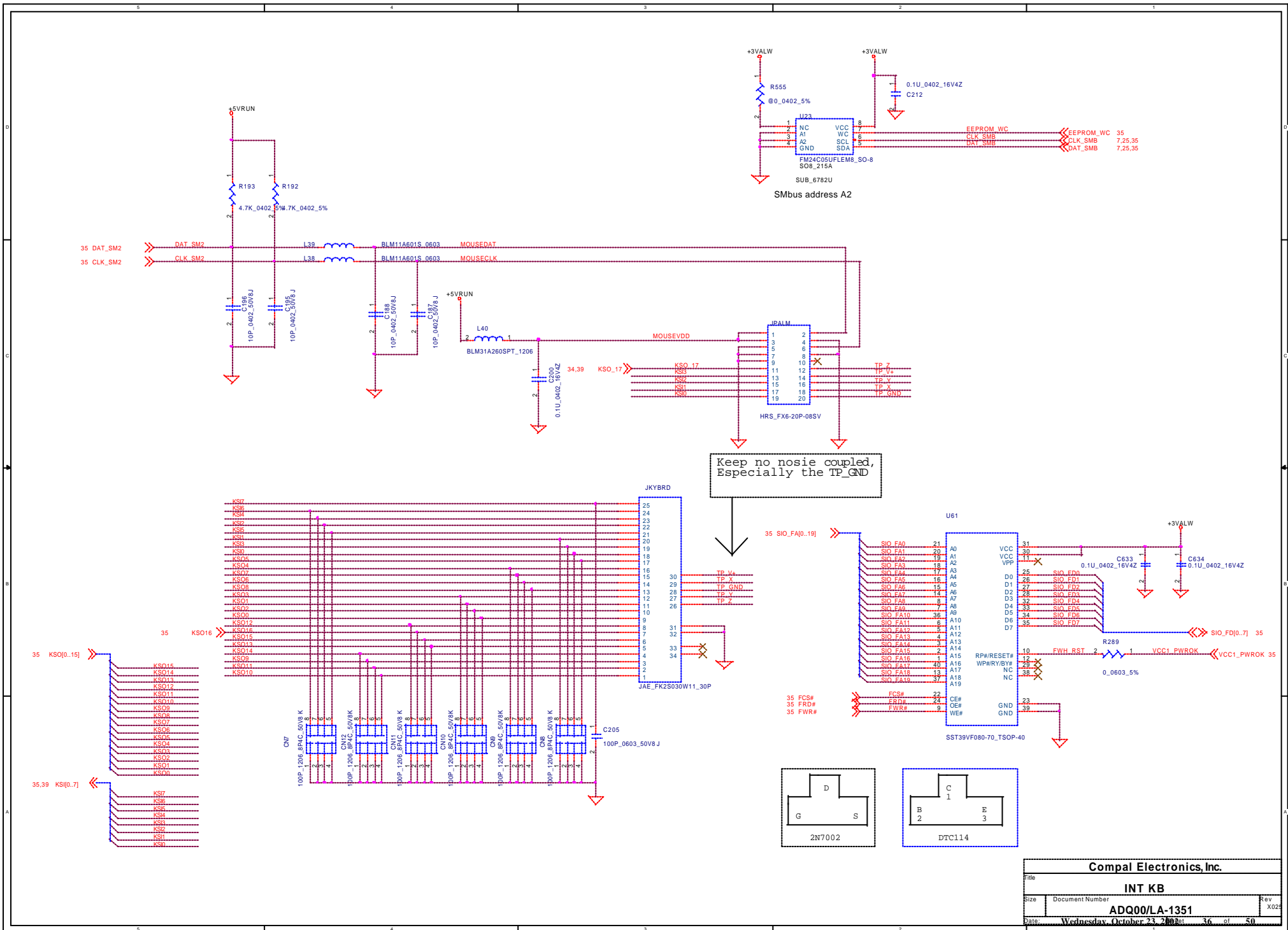

Parallel Port

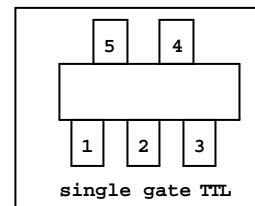
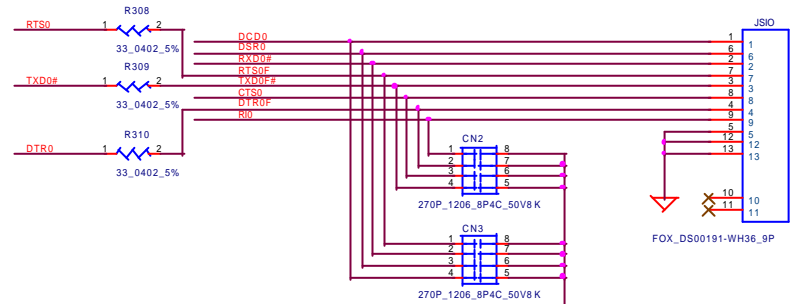
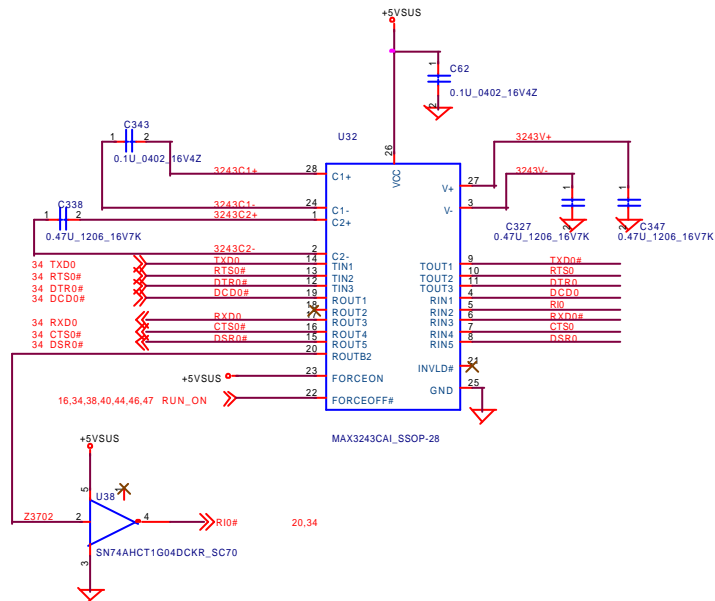
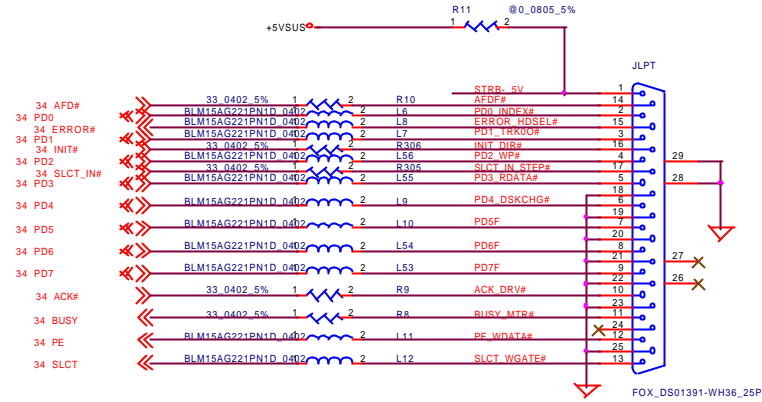
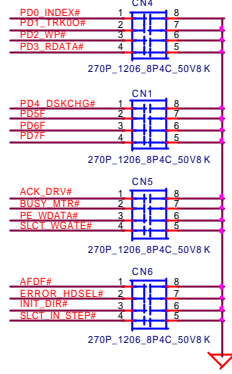
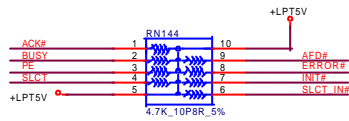
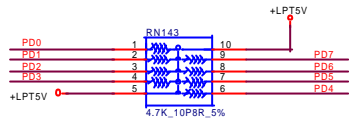
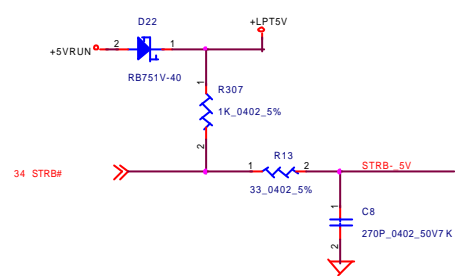

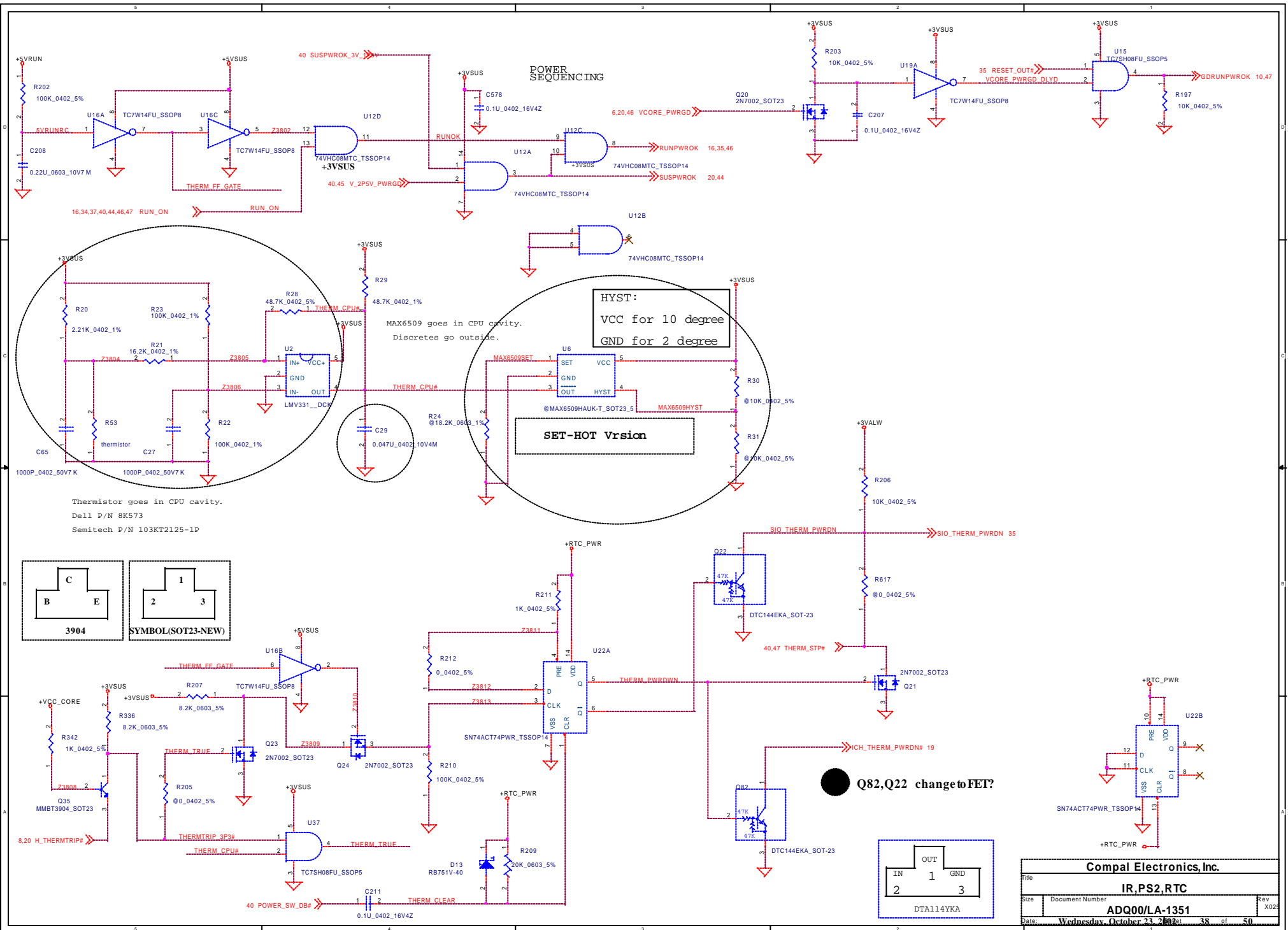

Thermistor goes in CPU cavity.
 Dell P/N 8K573
 Semitech P/N 103KT2125-1P

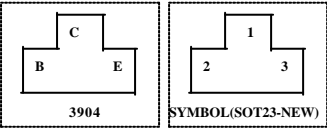

Q82, Q22 change to FET?

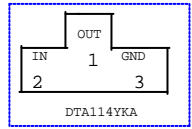

Compal Electronics, Inc.		
IR, PS2, RTC		
Size	Document Number	Rev
	ADQ00/LA-1351	X025
Date:	Wednesday, October 23, 2002	38 of 50

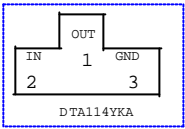
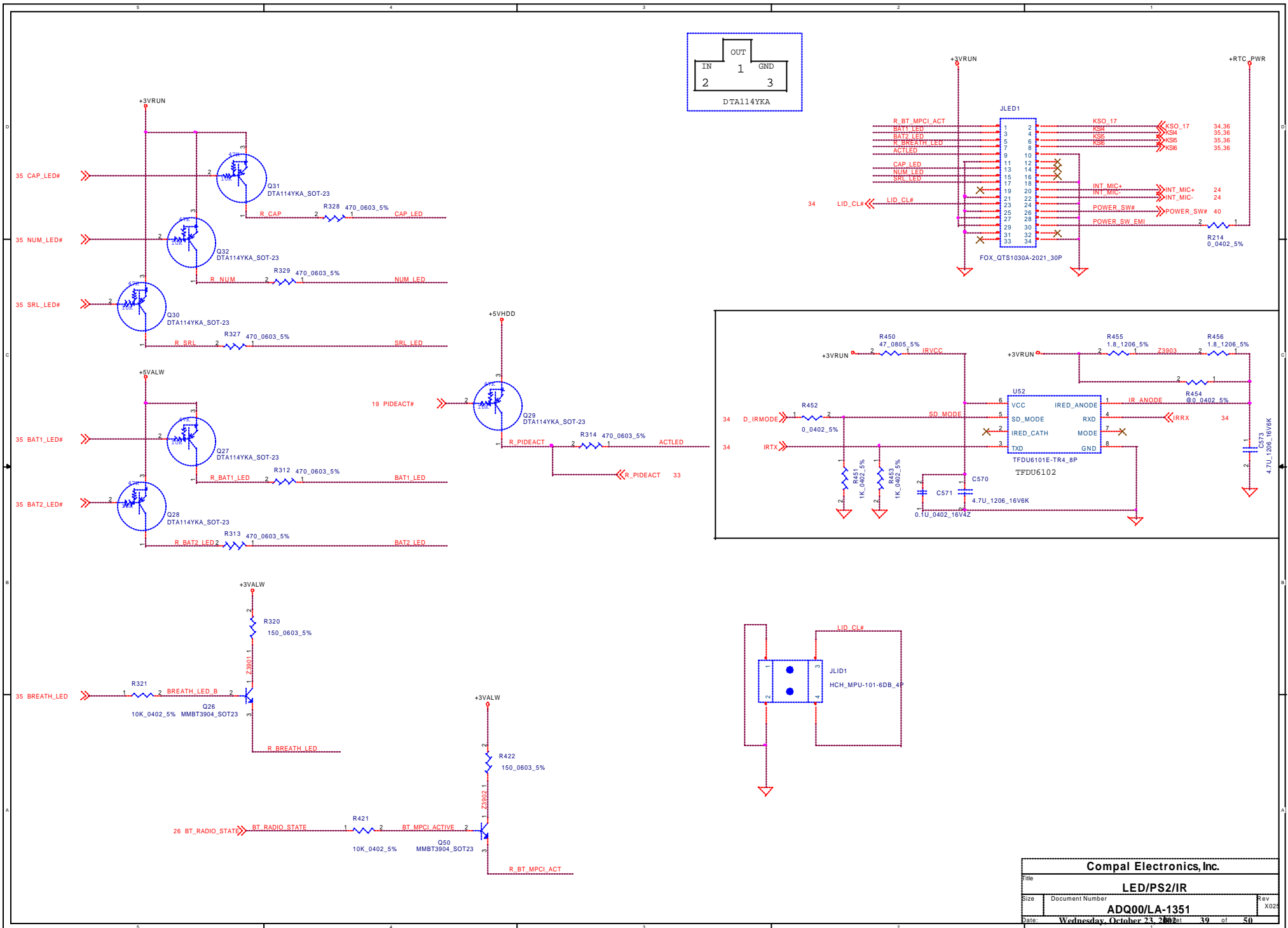

Compal Electronics, Inc.		
Title		
LED/PS2/IR		
Size	Document Number	Rev
	ADQ00/LA-1351	X025
Date:	Wednesday, October 23, 2002	39 of 50

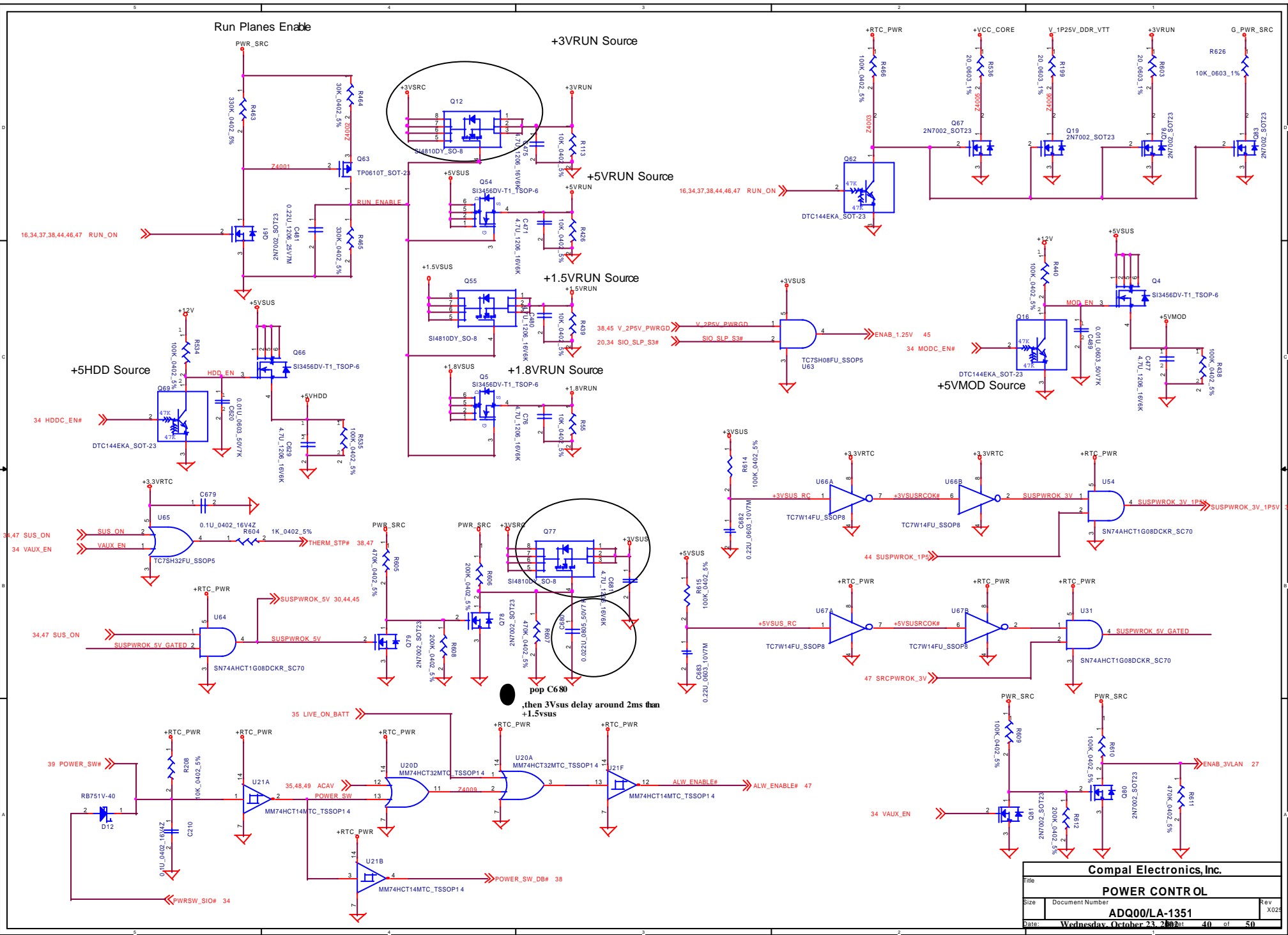

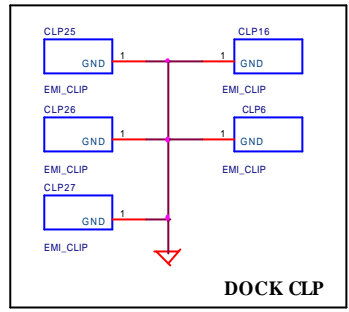
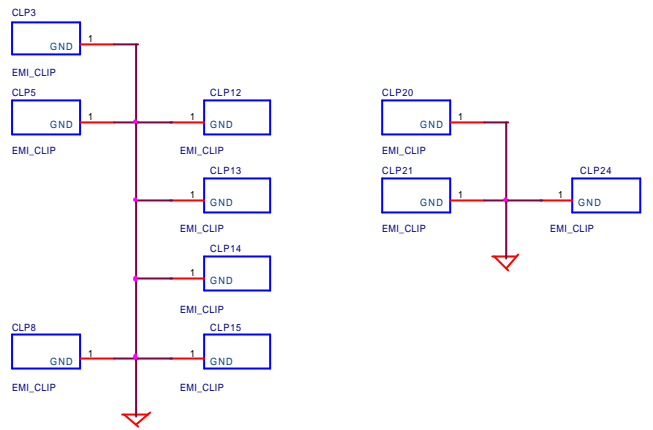

DOCK CLP

Fiducial Mark

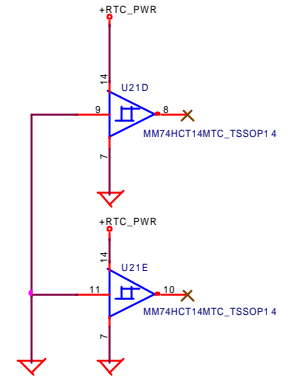
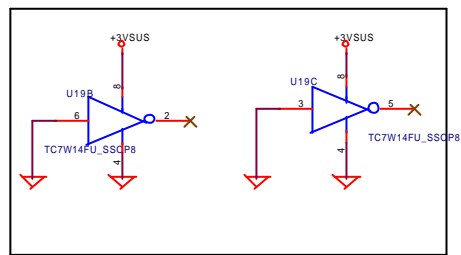
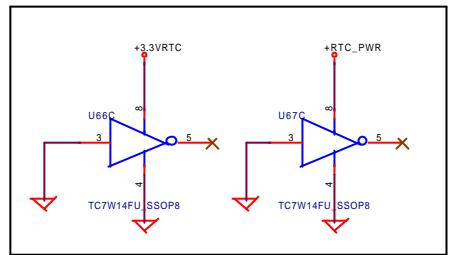
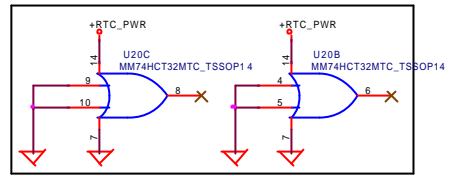
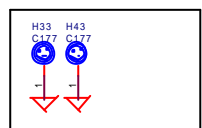
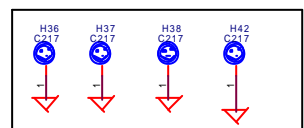
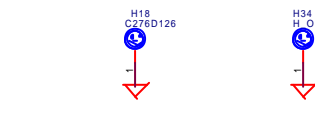
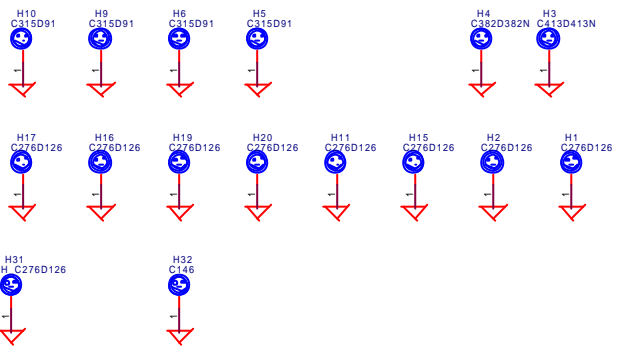
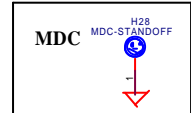
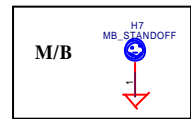
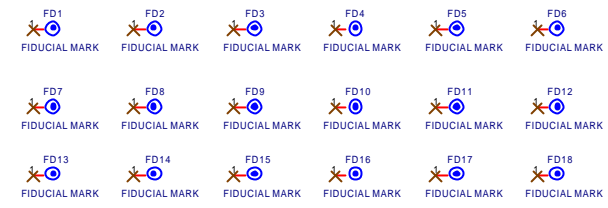

Compal Electronics, Inc.		
PAD and Standoff		
Title		
Size	Document Number	Rev
	ADQ00/LA-1351	X025
Date	Wednesday, October 23, 2002 4:11 of 50	

Rbat to PWR_SRC Enable

+RTCSRC Source

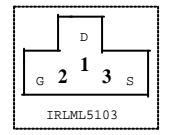
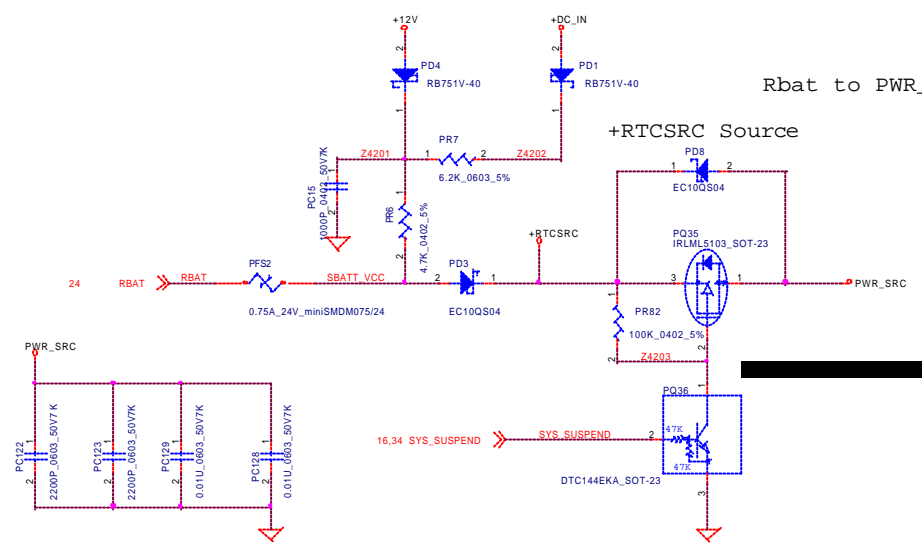

Z-series AC Adaptor Connector

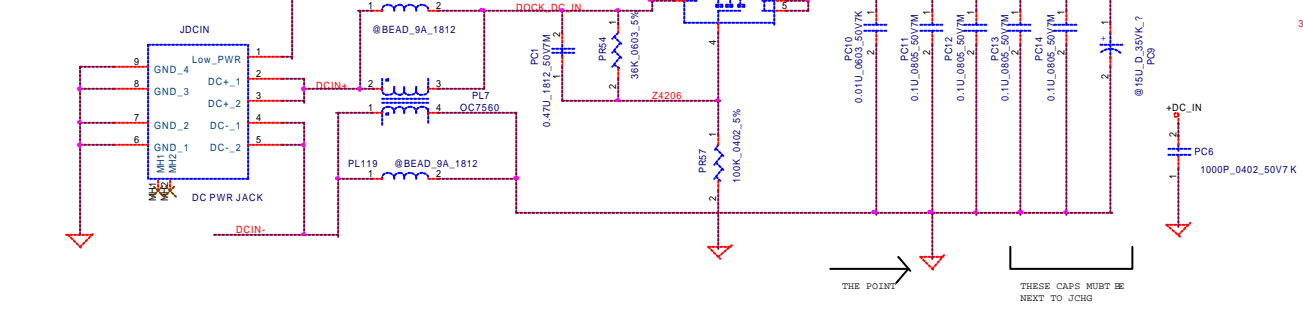

NOTE: *THE POINT LOCKED AT PS MODULE

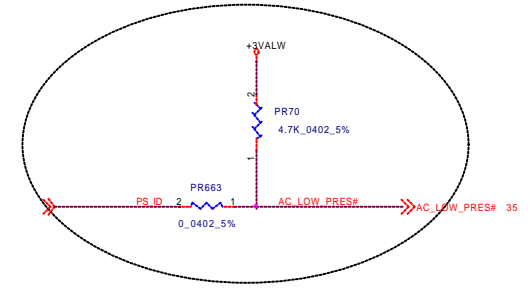
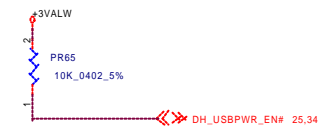

Old Low-Power Adapter Detection

Compal Electronics, Inc.		
Title DC-IN		
Size	Document Number	Rev
	ADQ00/LA-1351	X025
Date	Wednesday, October 23, 2002	42 of 50

Secondary Battery Connector

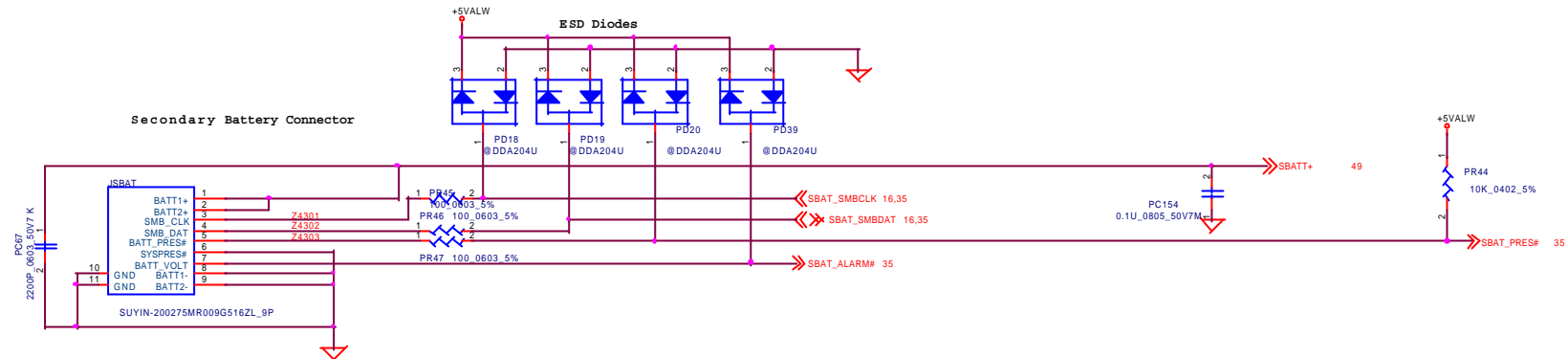

SUYIN_20175A-09G1

TRACE →
THE POINT →

Primary Battery Connector

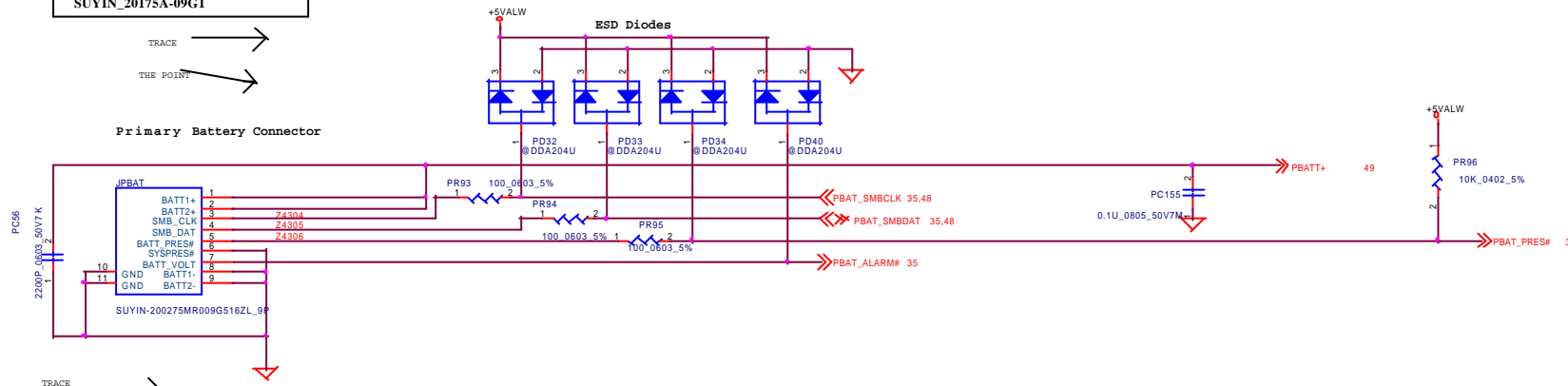

TRACE →
THE POINT →

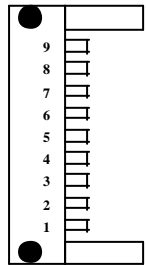

SUYIN_20175A-09G1
TOP view

Compal Electronics, Inc.		
Title Battery CONN.		
Size	Document Number ADQ00/LA-1351	Rev X025
Date	Wednesday, October 23, 2008 4:43 of 50	

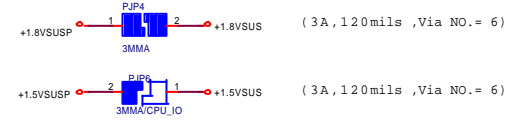
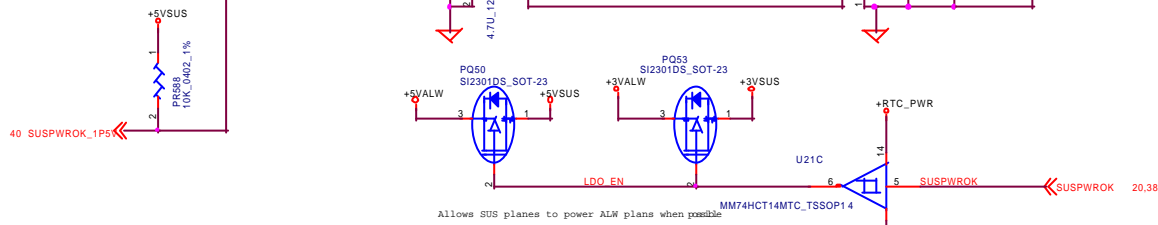
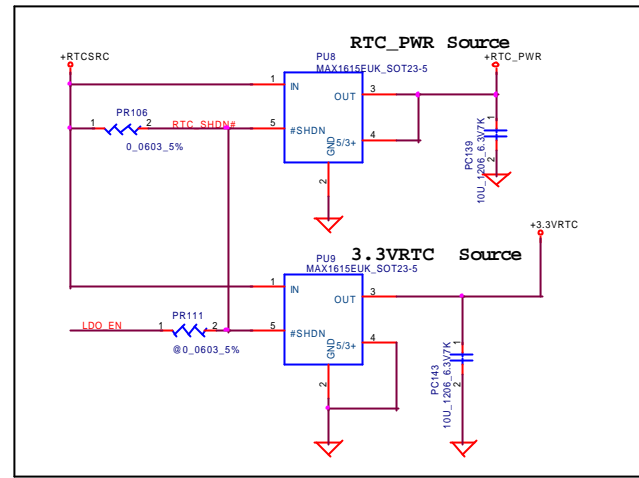
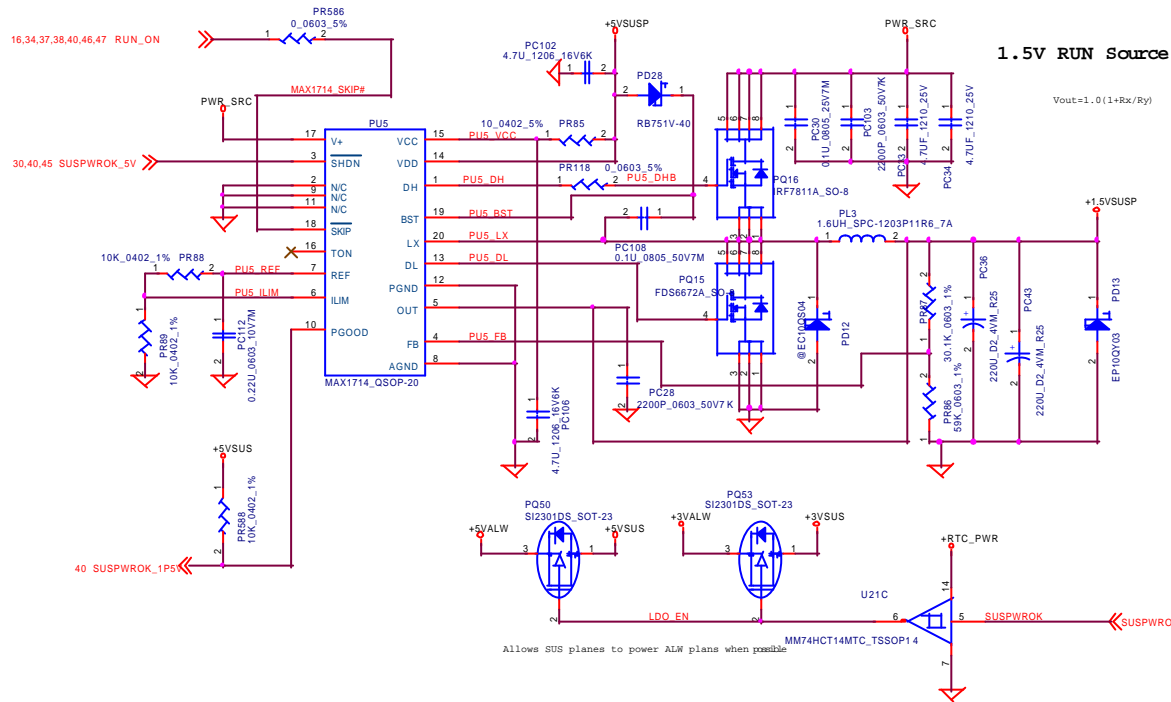

Compal Electronics, Inc.		
Title 1.5V/1.8V		
Size	Document Number ADQ00/LA-1351	Rev X023
Date	Wednesday, October 23, 2008	44 of 50

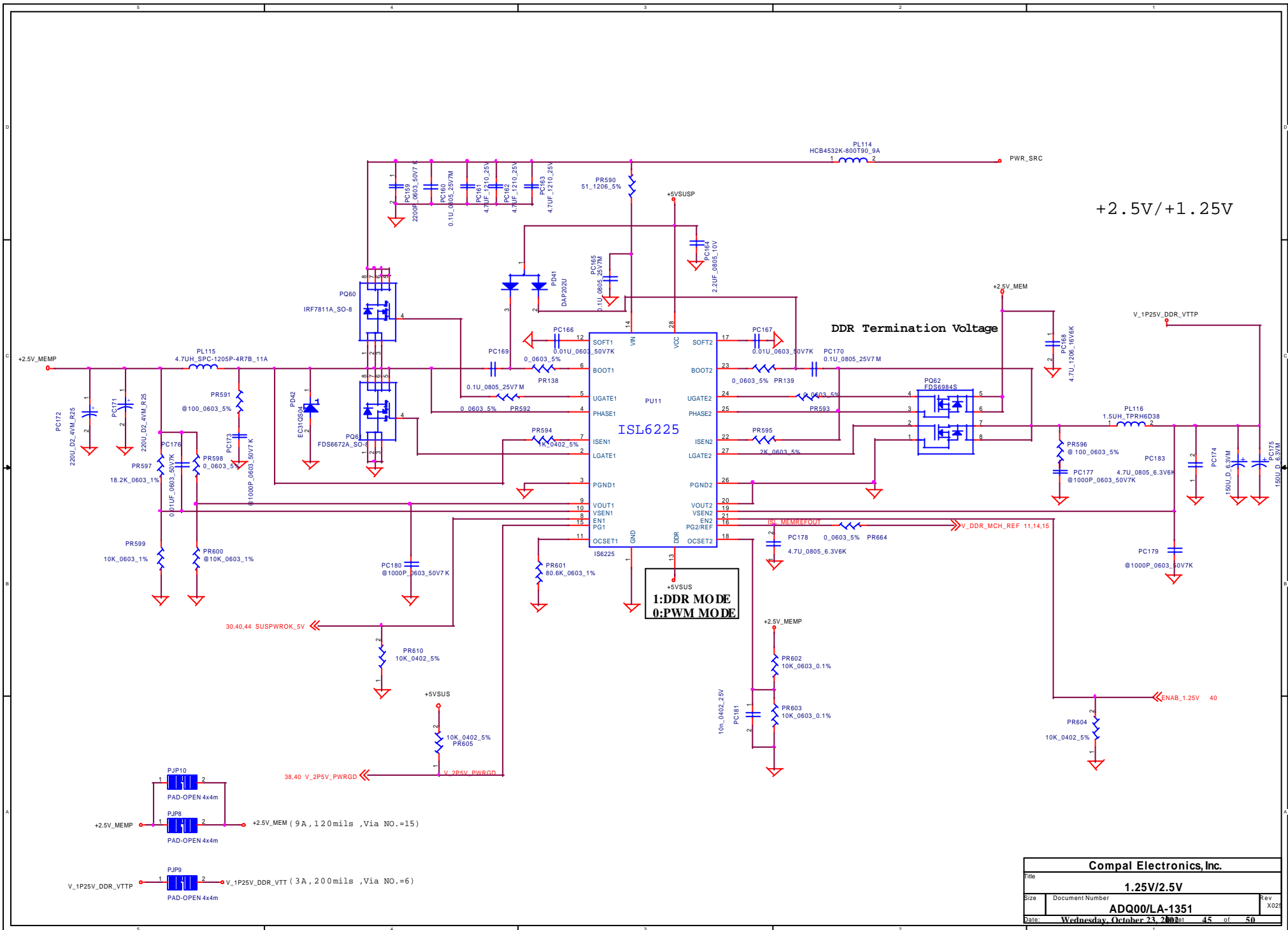

+2.5V/+1.25V

DDR Termination Voltage

1:DDR MODE
0:PWM MODE

Compal Electronics, Inc.		
Title 1.25V/2.5V		
Size	Document Number	Rev
	ADQ00/LA-1351	X023
Date	Wednesday, October 23, 2008	45 of 50

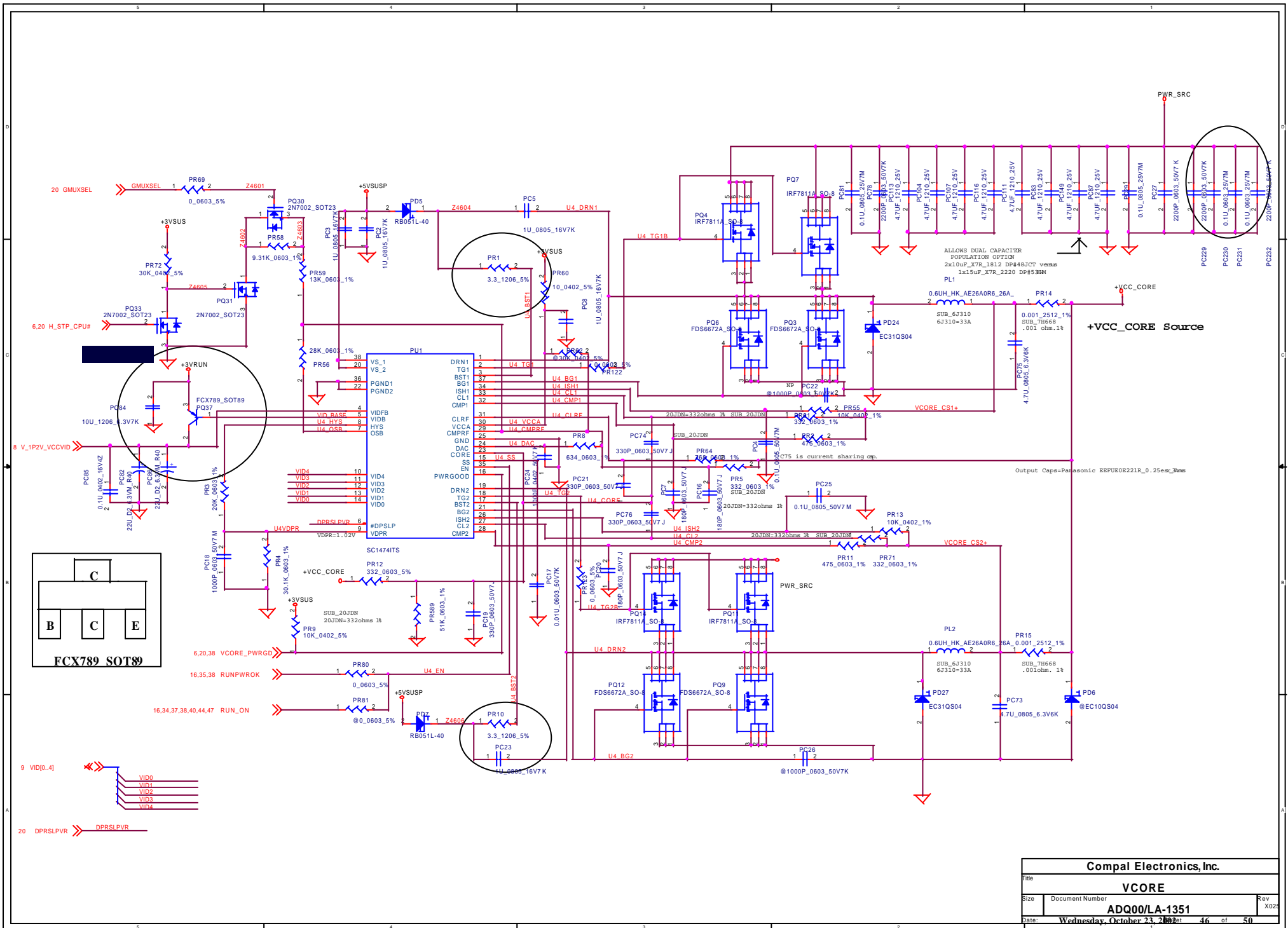

Compal Electronics, Inc.		
VCORE		
File	Document Number	Rev
	ADQ00/LA-1351	X025
Date	Wednesday, October 23, 2002	46 of 50

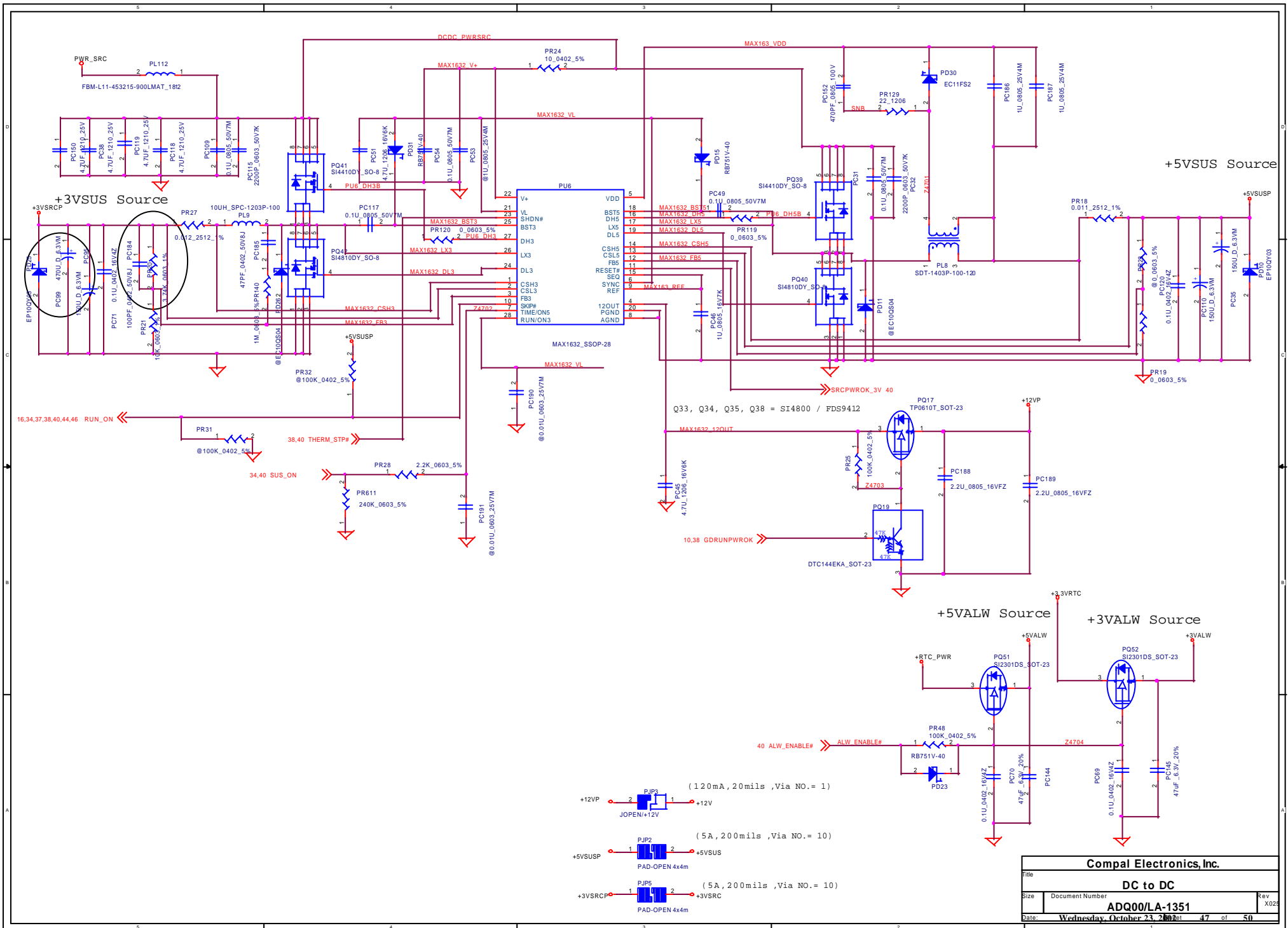

Compal Electronics, Inc.		
DC to DC		
ADQ00/LA-1351		
File	Document Number	Rev
Size		X023
Date	Wednesday, October 23, 2008	47 of 50

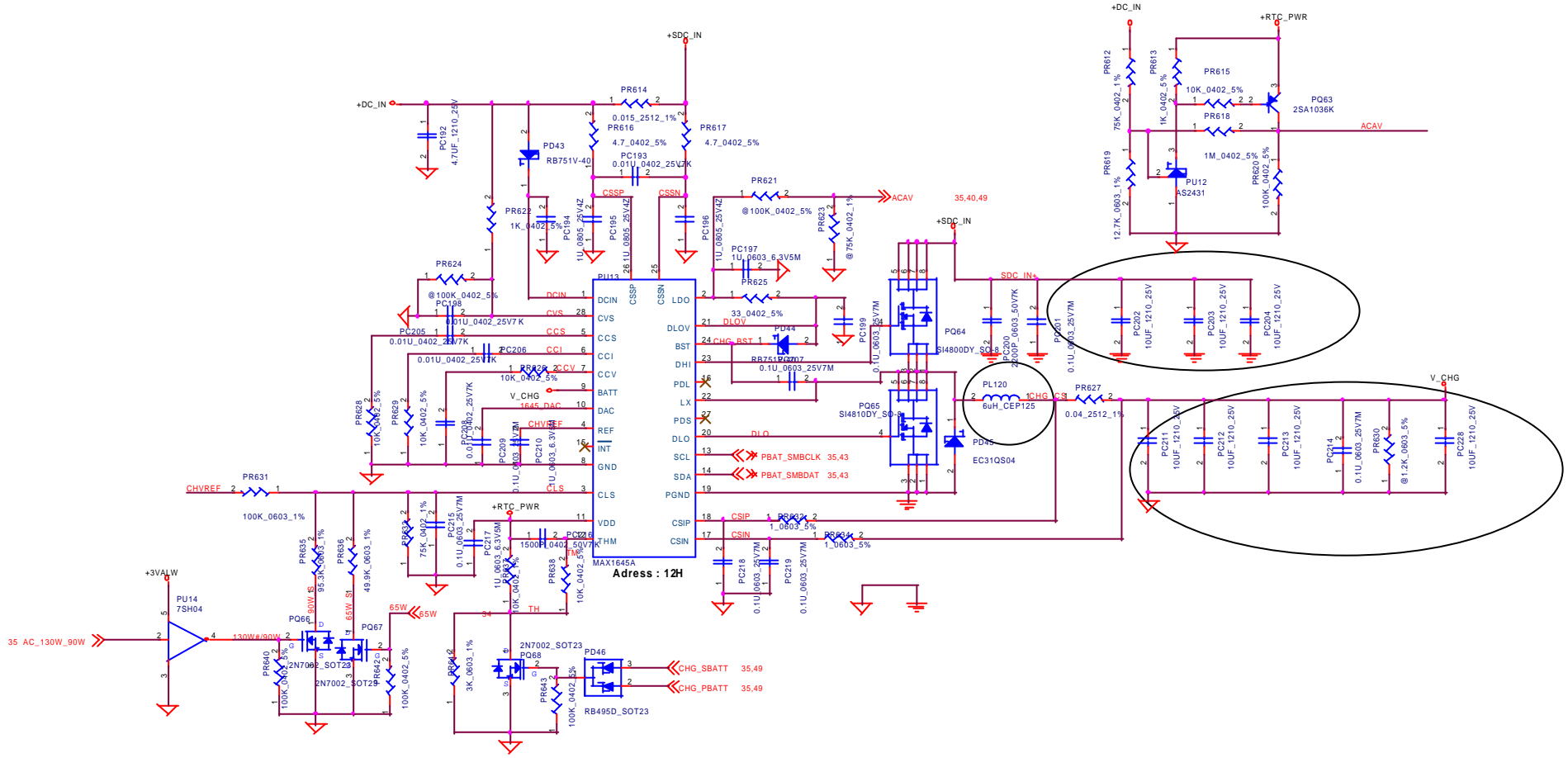

	65W (2.53A)	90W (4.03A)	130W (5.85A)
65W	H	L	L
130W#/90W	H	H	L

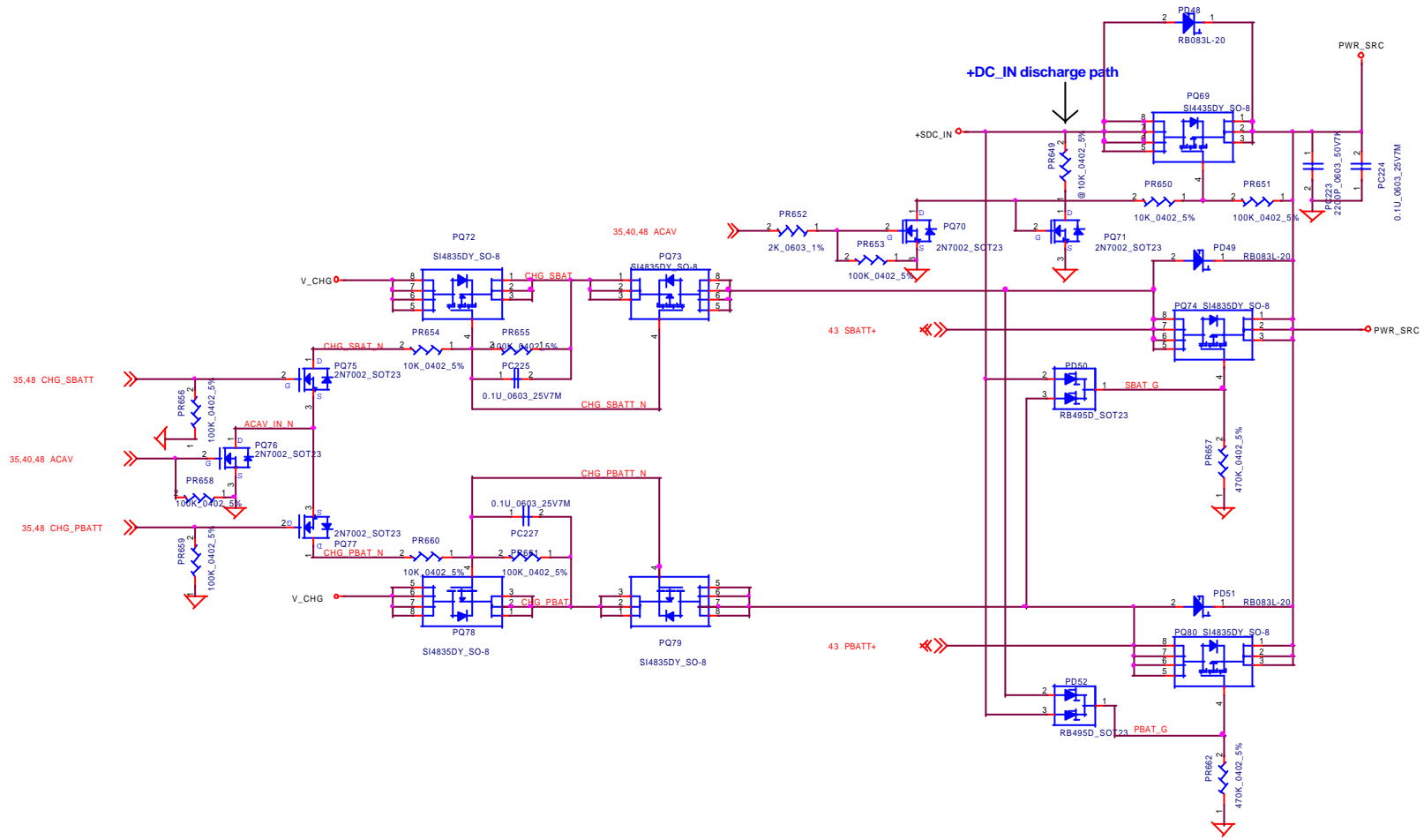

Compal Electronics, Inc.		
CHARGER		
Title	Document Number	Rev
	ADQ00/LA-1351	X025
Date	Wednesday, October 23, 2008	49 of 50

**THIS PAGE IS ONLY FOR
B.O.M. INFORMATION**

PIR

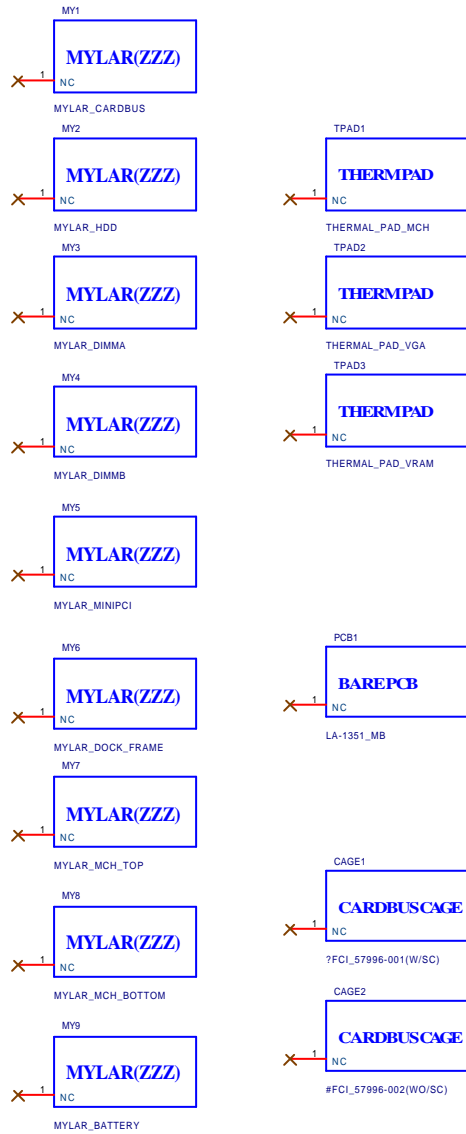

ITEM	PAGE	REV.	NOTE		
1	9	X025	remove CPU VCCID jumper		
2	19	X025	Change R537 to 1K for PIDEACT# PU		
3	20	X025	remove SIO_LID_EC# signal ,PU 1CH4GPIO to +3VRUN		
4	21	X025	change JMOD1 pin8,10,14,16,9,11, to NC,conect SATA_DET# to pin13	reserve C693,R629,R630 for CD AUDIO termination	
5	25	X025	change Q1,F1,F2,L25 part to meet Doghouse power current requirement	add R639 for USB port 3 power enable, reserve R640	
6	27	X025	add L109, L110 for BCM4401 PCI power for WOL issue		
7	28	X025	add eight 8.2uH inductor to TX/RX line	seperate RN1 to 4 small resistors	Change Q36 to 2N7002
8	29	X025	remove D11 for TI_SUSPEND#		
9	31	X025	Change JPC11 pin109 and pin 123 to NC and remove R457,C576		
10	34	X025	add R628 PU to U27 pin D12		
11	35	X025	reserve R634 for TI_SUSPEND#		
12	38	X025	change OTP to discrete solution		
13	40	X025	change Q12 and Q77 to SI4810		
14	42	X025	remove AC LOW PRES circuit		
15	46	X025	change PQ37 to FCX789	remove PC147 change PR1,PR10 to 3.3ohm	add PC229,PC230,PC231,PC232
16	47	X025	change PR20 to 3.74K		
17	48	X025	addPC228,change C202,PC203, PC204,PC211,PC212,PC213,PC214 to 10uF/25V	Change PL120 to 6uH	