

SEL_SRC0 (Pin 17,18) (R4)
 0: LCDCCLK Pair
 1: SRCCLK0 pair

SEL_SATA (Pin 26, 27) (R44)
 0: Clock from SRC PLL
 1: Clock from SATA PLL

SEL_LCD (Pin 17,18) (R6)
 0: 27MHzSS/27MHzSS# pair (M24/M26)
 1: LCDCCLK pair (915GM)

ITP_EN Function (Pin 35,36) (R15)
 0: SRC_7 Pair (Pin 35,36)
 1: CPU_2_ITP Pair (Pin 35,36)

IREF (Pin 39) :
 475_1% : Sets the IREF current to 2.32mA

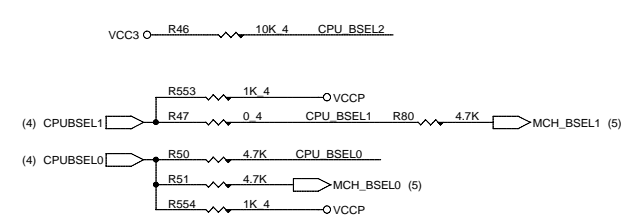

FSC BSEL0	FSB BSEL1	FSA BSEL2	CPU	SRC	PCI	REF	USB	DOT	Spread %
0	0	0	266.66	100	33.33	14.318	48	96	0.5 Down
* 0	0	1	133.33	100	33.33	14.318	48	96	0.5 Down
0	1	0	200.00	100	33.33	14.318	48	96	0.5 Down
0	1	1	166.66	100	33.33	14.318	48	96	0.5 Down
1	0	0	333.33	100	33.33	14.318	48	96	0.5 Down
* 1	0	1	100.00	100	33.33	14.318	48	96	0.5 Down
1	1	0	400.00	100	33.33	14.318	48	96	0.5 Down
1	1	1	200.00	100	33.33	14.318	48	96	0.5 Down

LCDCCLK Spread and Frequency Selection Table (SEL_LCD) :

SEL_LCD	SS3	SS2	SS1	SS0	VCO MHZ	17,18 MHZ	Spread %	SEL_LCD	SS3	SS2	SS1	SS0	VCO MHZ	17,18 MHZ	Spread %
1	0	0	0	0	500	100	+/-1.5	0	0	0	0	0	864	27	+/-0.25
1	0	0	0	1	500	100	+/-1.25	0	0	0	0	1	864	27	+/-0.5
1	0	0	1	0	500	100	+/-1.0	0	0	0	1	0	864	27	+/-0.75
1	0	0	1	1	500	100	+/-0.8	0	0	0	1	1	864	27	+/-1
1	0	1	0	0	500	100	+/-0.6	0	0	1	0	0	864	27	+/-1.25
1	0	1	0	1	500	100	+/-0.5	0	0	1	0	1	864	27	+/-1.5
1	0	1	1	0	500	100	+/-0.4	0	0	1	1	0	864	27	+/-1.75
1	0	1	1	1	500	100	+/-0.3	0	0	1	1	1	864	27	+/-2
1	1	0	0	0	500	100	3	0	1	0	0	0	864	27	-0.5
1	1	0	0	1	500	100	2.5	0	1	0	0	1	864	27	-1
1	1	0	1	0	500	100	2	0	1	0	1	0	864	27	-1.25
1	1	0	1	1	500	100	1.75	0	1	0	1	1	864	27	-1.5
1	1	1	0	0	500	100	1.5	0	1	1	0	0	864	27	-1.75
1	1	1	0	1	500	100	1.25	0	1	1	0	1	864	27	-2
1	1	1	1	0	500	100	1	0	1	1	1	0	864	27	-2.5
1	1	1	1	1	500	100	0.8	0	1	1	1	1	864	27	-3

SATA Spread and Frequency Selection Table (SEL_SATA) :

SEL_SATA	SS3	SS2	VCO MHZ	27,26 MHZ	Spread %
1	0	0	tbd	100	-0.2 Down
1	0	1	tbd	100	-0.3 Down
1	1	0	tbd	100	-0.4 Down
1	1	1	tbd	100	-0.5 Down

Signal		915GM	915PM
CLK_PCIE_M24	RP32	NI	33X2
	RP45	NI	49.9/Fx2_4
DREFSSCLK	RP36	33X2	NI
	RP48	49.9/Fx2_4	NI
DREFCLK	RP37	33X2	NI
	RP49	49.9/Fx2_4	NI
DREFSSCLK	R528	NI	121/F
	R529	NI	33
R_PCLK_ICh6	R6	NI	10K_4

QUANTA COMPUTER

Title: **CLOCK GENERATOR**

Size: _____ Document Number: _____ Rev 1A

RJ5 Main Board

Date: Tuesday, May 10, 2005 Sheet 2 of 36

1. This part should not contain any substances which are specified in SS-00259-1
 2. Purchase ink, paint, wire rods and molding resins only from the business partners that Sony approves as Green Partners.

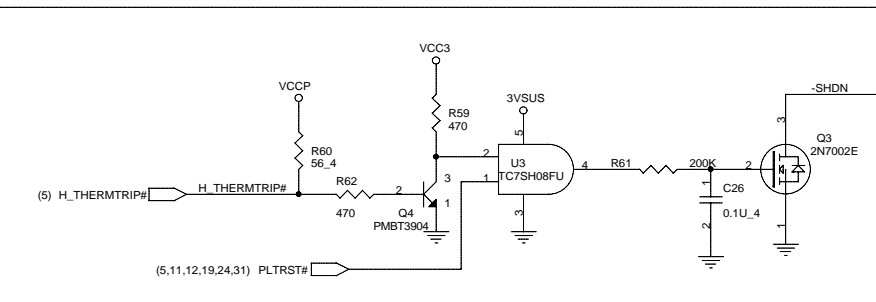
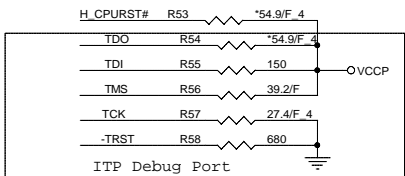
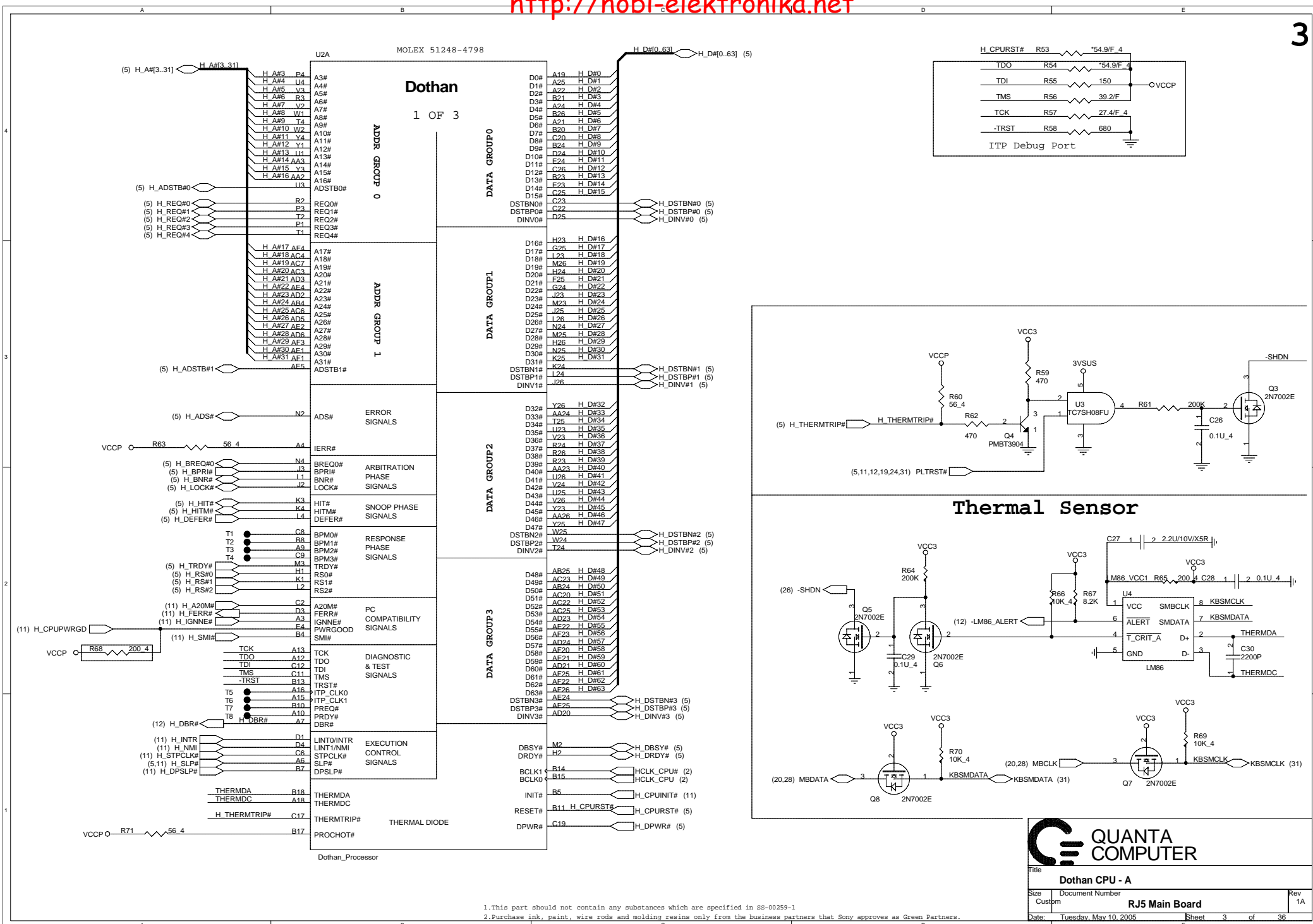

Thermal Sensor

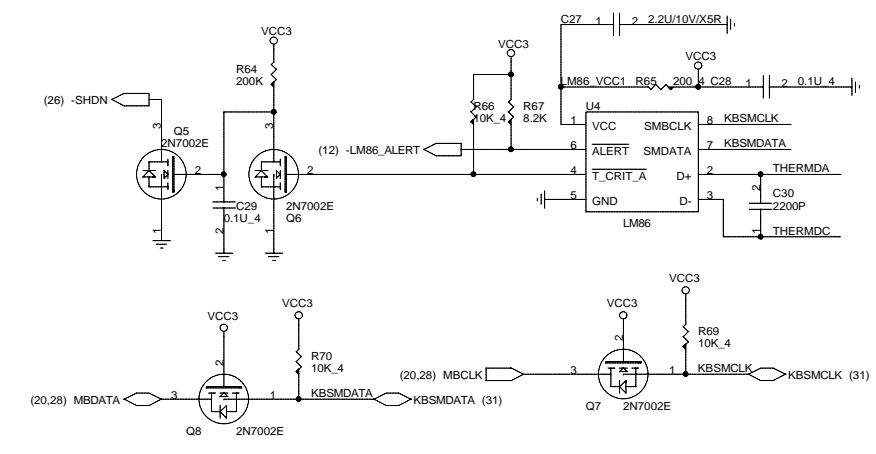

QUANTA COMPUTER

Title: **Dothan CPU - A**

Size: Document Number
 Custom: **RJ5 Main Board**
 Date: Tuesday, May 10, 2005 Sheet 3 of 36 Rev 1A

1. This part should not contain any substances which are specified in SS-00259-1
 2. Purchase ink, paint, wire rods and molding resins only from the business partners that Sony approves as Green Partners.

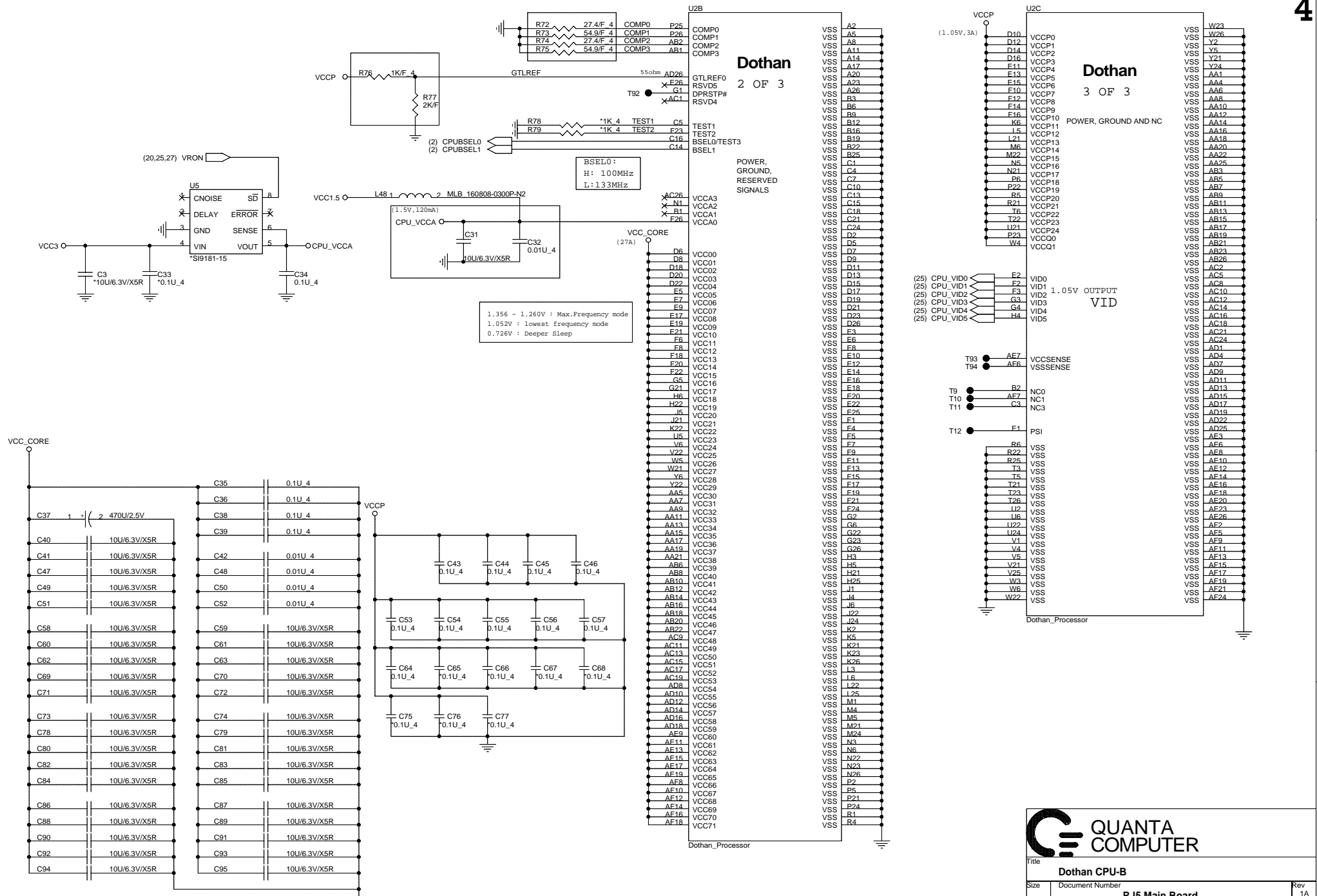

Title		Dothan CPU-B	
Size	Document Number	Rev 1A	
RJ5 Main Board		Date:	Tuesday, May 10, 2005
		Sheet	4 of 36

1. This part should not contain any substances which are specified in SS-00259-1
 2. Purchase ink, paint, wire rods and molding resins only from the business partners that Sony approves as Green Partners.

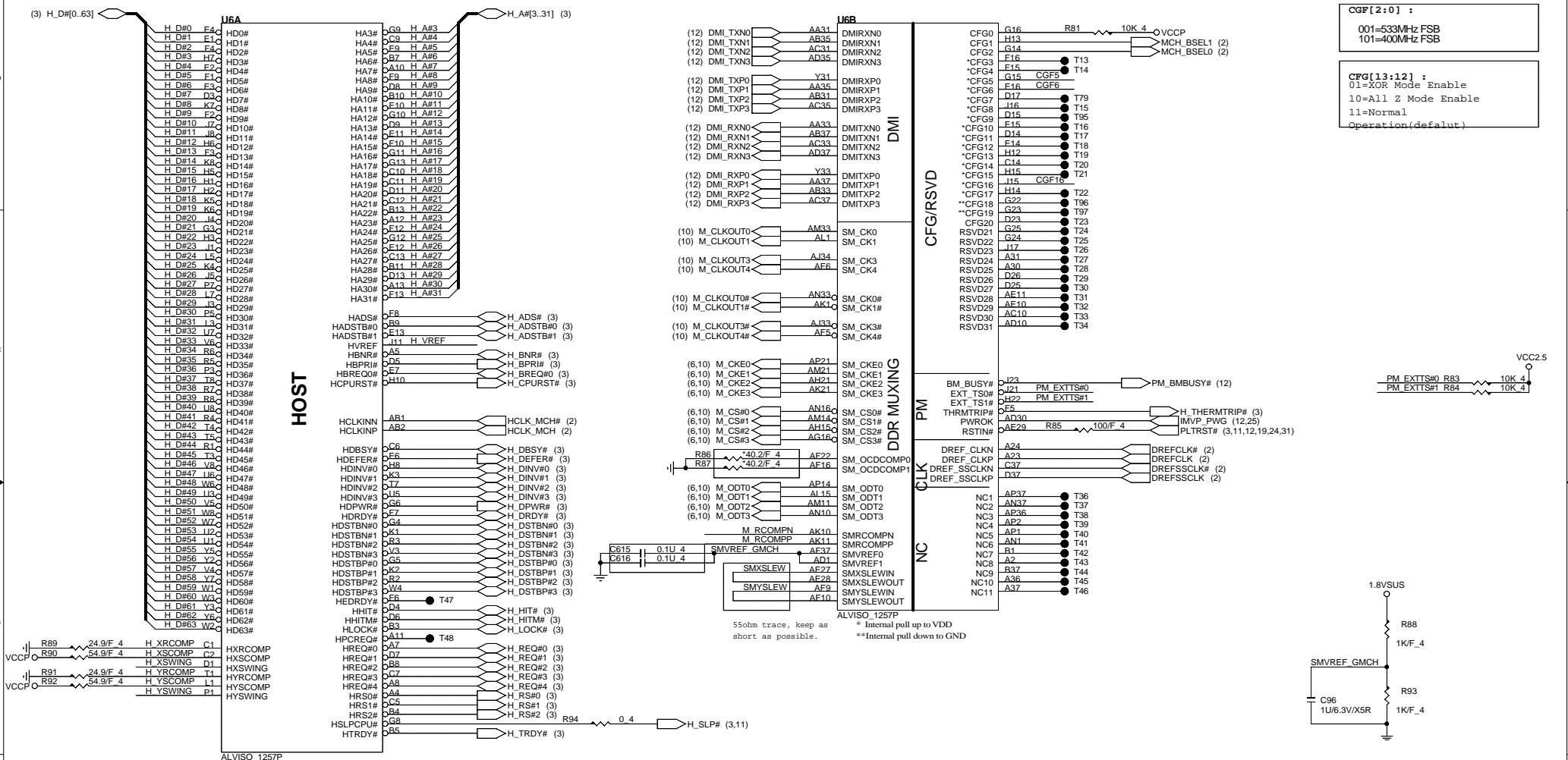

CGF[2:0] :
 001=533MHz FSB
 101=400MHz FSB

CFG[13:12] :
 01=XOR Mode Enable
 10=All Z Mode Enable
 11=Normal
 Operation (default)

VCC2.5

PM_EXTT#0 R83 10K 4
 PM_EXTT#1 R84 10K 4

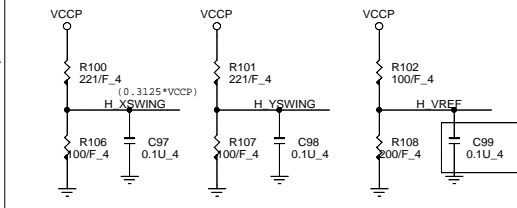
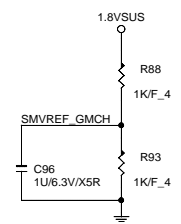

	Low	High
CGF5	DMi2	DMi4
CGF6	DDR II	DDR
CGF7	CPU type: DT/Transportable	CPU type: Mobile CPU
CGF9	PCIe Graphics lan : Reverse Lane	PCIe Graphics lan : Normal operation
CGF16	Dynamic ODT Disabled	Dynamic ODT Enabled
CGF18	Alviso GMCH core: 1.05V	Alviso GMCH core: 1.5V
CGF19	VPP Voltage : 1.05V	VPP Voltage : 1.2V

Note:
 CFG[17:3] have internal pullup resistors.
 CFG[19:18] have internal pulldown resistors.

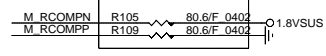
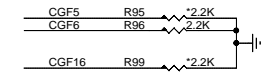

	H_SLP#
For Doathan A-X step	* 0
* For Doathan B-X step & later	0

SDVOCRTL_DATA :
 * 0 : No SDVO Device Present (default)
 1 : SDVO Device Present

QUANTA COMPUTER

Title: **Alviso**

Size: Document Number: **RJ5 Main Board** Rev: **1A**

Date: Tuesday, May 10, 2005 Sheet 5 of 36

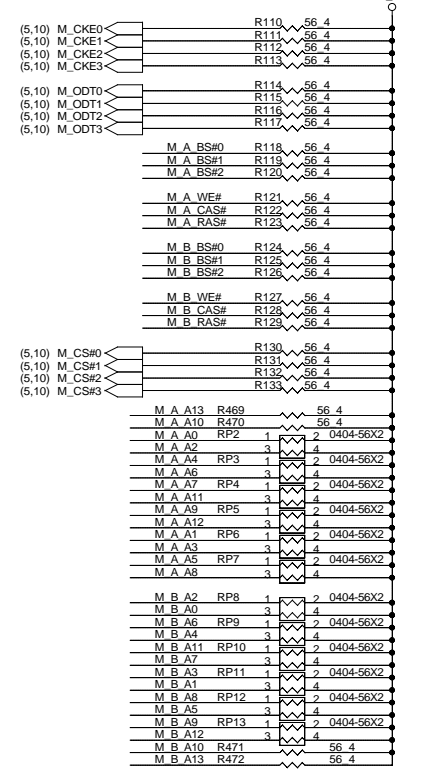
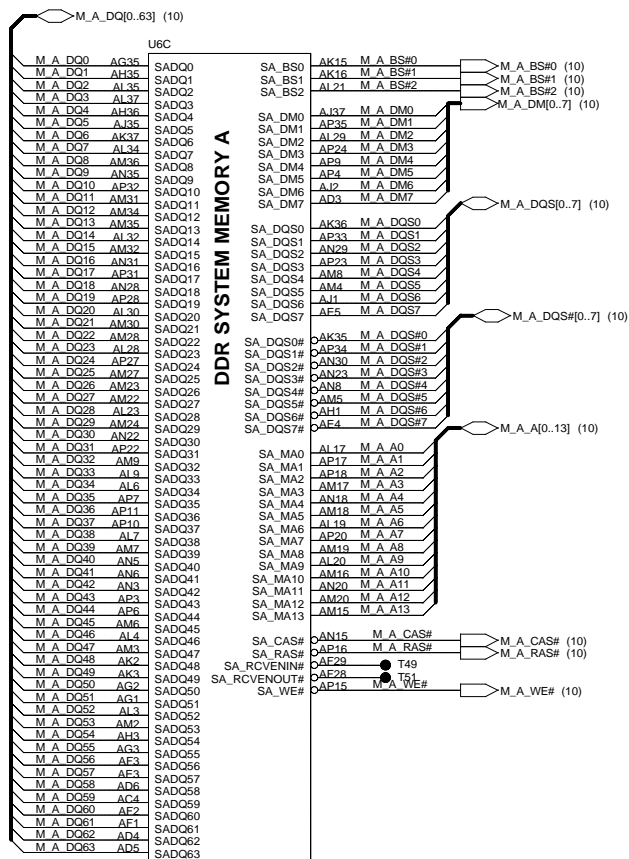

ALVISO_125P7

ALVISO_125P7

VTT_MEM	Value	Pin
C100	*10U/6.3V/X5R	56 4
C101	*10U/6.3V/X5R	56 4
C102	0.1U 4	56 4
C103	0.1U 4	56 4
C104	0.1U 4	56 4
C105	0.1U 4	56 4
C106	0.1U 4	56 4
C107	0.1U 4	56 4
C108	0.1U 4	56 4
C109	0.1U 4	56 4
C110	0.1U 4	56 4
C111	*0.1U 4	56 4
C112	*0.1U 4	56 4
C113	0.1U 4	56 4
C114	0.1U 4	56 4
C115	0.1U 4	56 4
C117	0.1U 4	56 4
C118	0.1U 4	56 4
C119	*0.1U 4	56 4
C121	0.1U 4	56 4
C122	0.1U 4	56 4
C123	0.1U 4	56 4
C124	*0.1U 4	56 4
C125	0.1U 4	56 4
C126	0.1U 4	56 4
C127	0.1U 4	56 4
C128	*0.1U 4	56 4
C129	0.1U 4	56 4

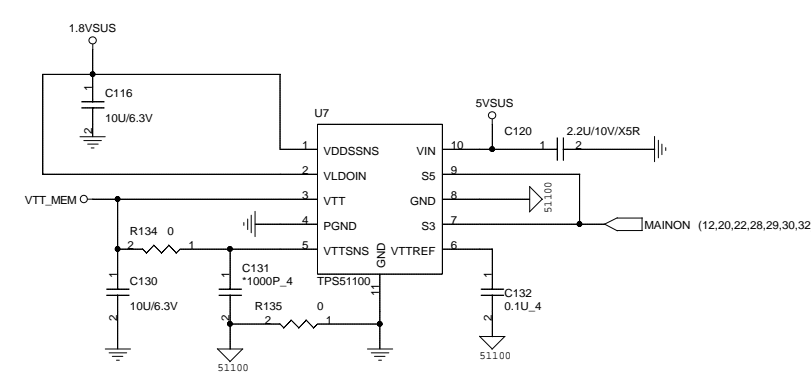

QUANTA COMPUTER

Title: **Alviso-DDRII**

Size: _____ Document Number: _____ Rev: 1A

RJ5 Main Board

Date: Tuesday, May 10, 2005 Sheet 6 of 36

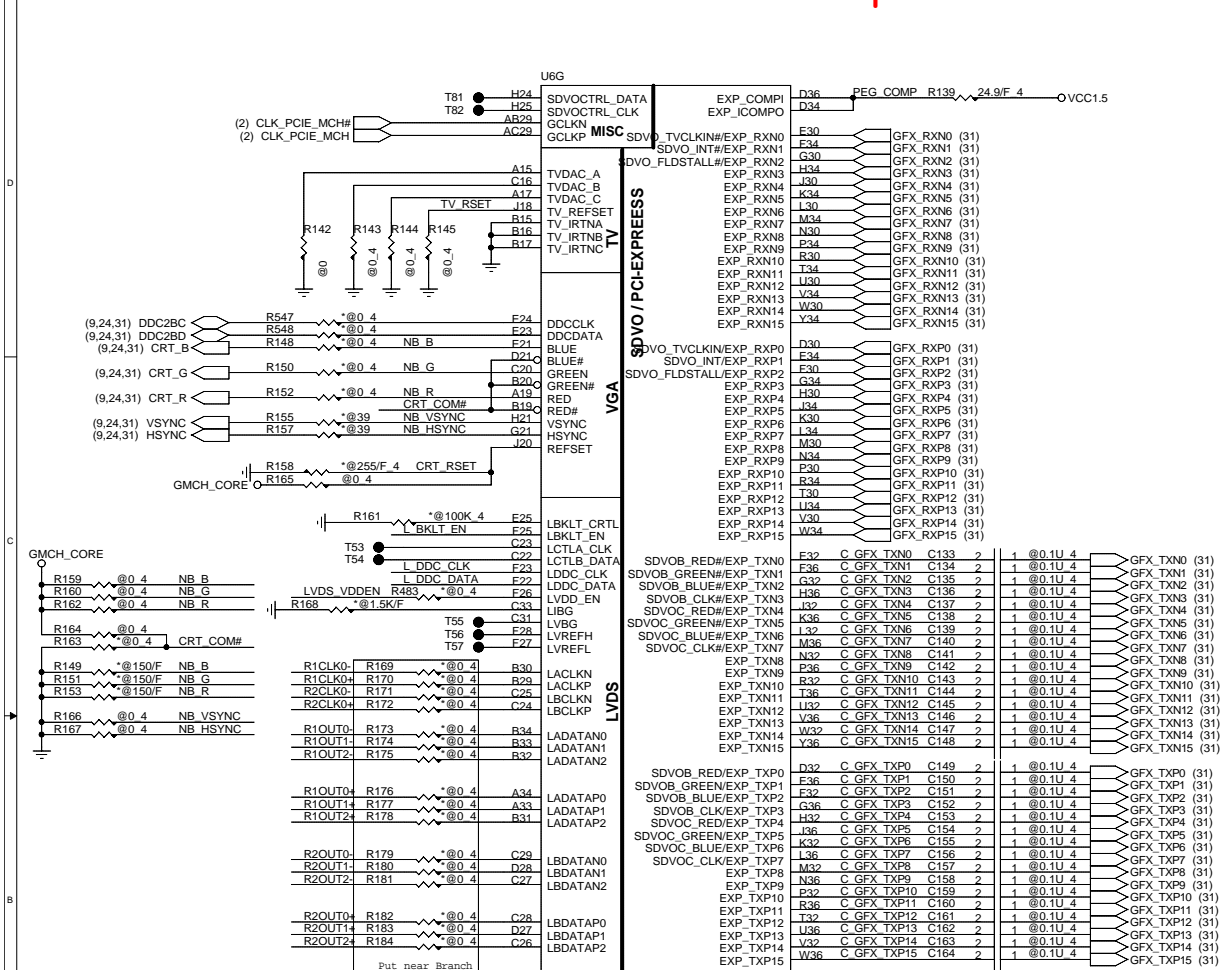

Signal	915GM	915PM
TV_RSET	R145 4.99K/F_0402	0_0402
TV_COMP	R142 150/F	0_0603
	R143 75/F 4	0_0402
	R144 75/F 4	0_0402
VSYNC	R155 39	NI
	R156 NI	0_0402
HSYNC	R157 39	NI
	R161 100K	NI
L_BKLT_CRTL	R140 100K	NI
	R168 1.5K	NI
L_BKLT_EN	O10 NI	NI
LVDS_CLK	R146 2.2K	NI
	O11 NI	NI
LVDS_DATA	R154 2.2K	NI
	R153 150/F	NI
NB_R	R152 0_0402	NI
	R151 150/F	NI
	R162 NI	0_0402
NB_G	R150 0_0402	NI
	R160 NI	0_0402
NB_B	R148 0_0402	NI
	R149 150/F	NI
	R159 NI	0_0402
CRT_COM#	R163 0_0402	NI
	R164 NI	0_0402
CRT_RSET	R158 255/F 0402	NI
	R165 NI	0_0402
LVDS	R169 0_0402	NI
	R170 0_0402	NI
	R171 0_0402	NI
	R172 0_0402	NI
	R173 0_0402	NI
	R174 0_0402	NI
	R175 0_0402	NI
	R176 0_0402	NI
	R177 0_0402	NI
	R178 0_0402	NI
	R179 0_0402	NI
	R180 0_0402	NI
	R181 0_0402	NI
	R182 0_0402	NI
	R183 0_0402	NI
	R184 0_0402	NI
LVDS_VDDEN	R483 0_0402	NI
GFX	C133 NI	0.1u_4
	-C164	
L_BKLT_EN	Q9 2N7002E	NI
	R138 2.2K	NI
	R547 0_0402	NI
	R548 0_0402	NI

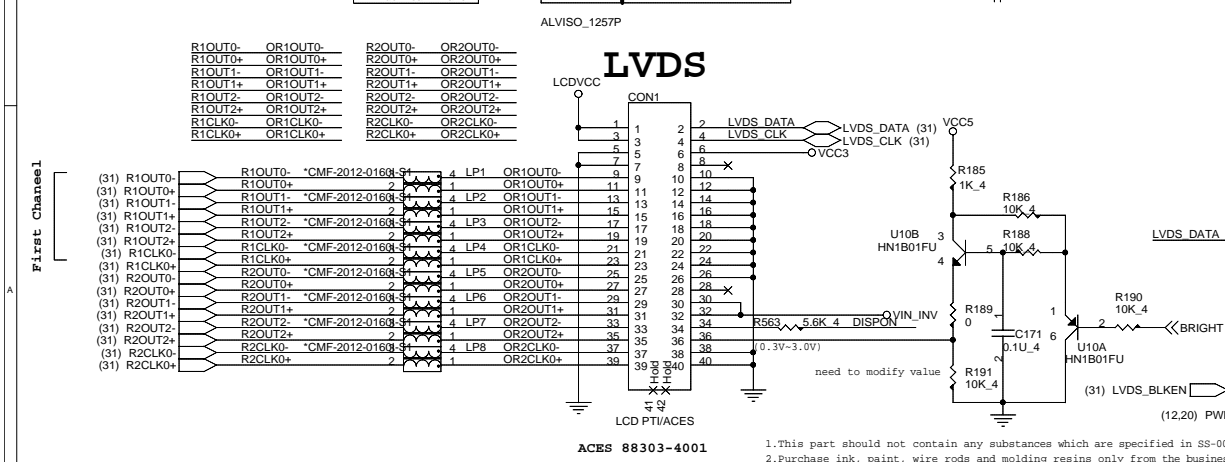
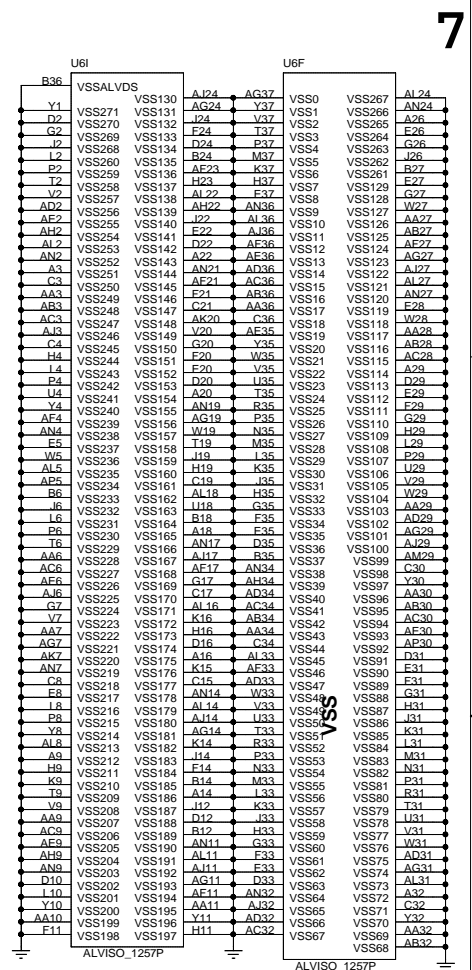

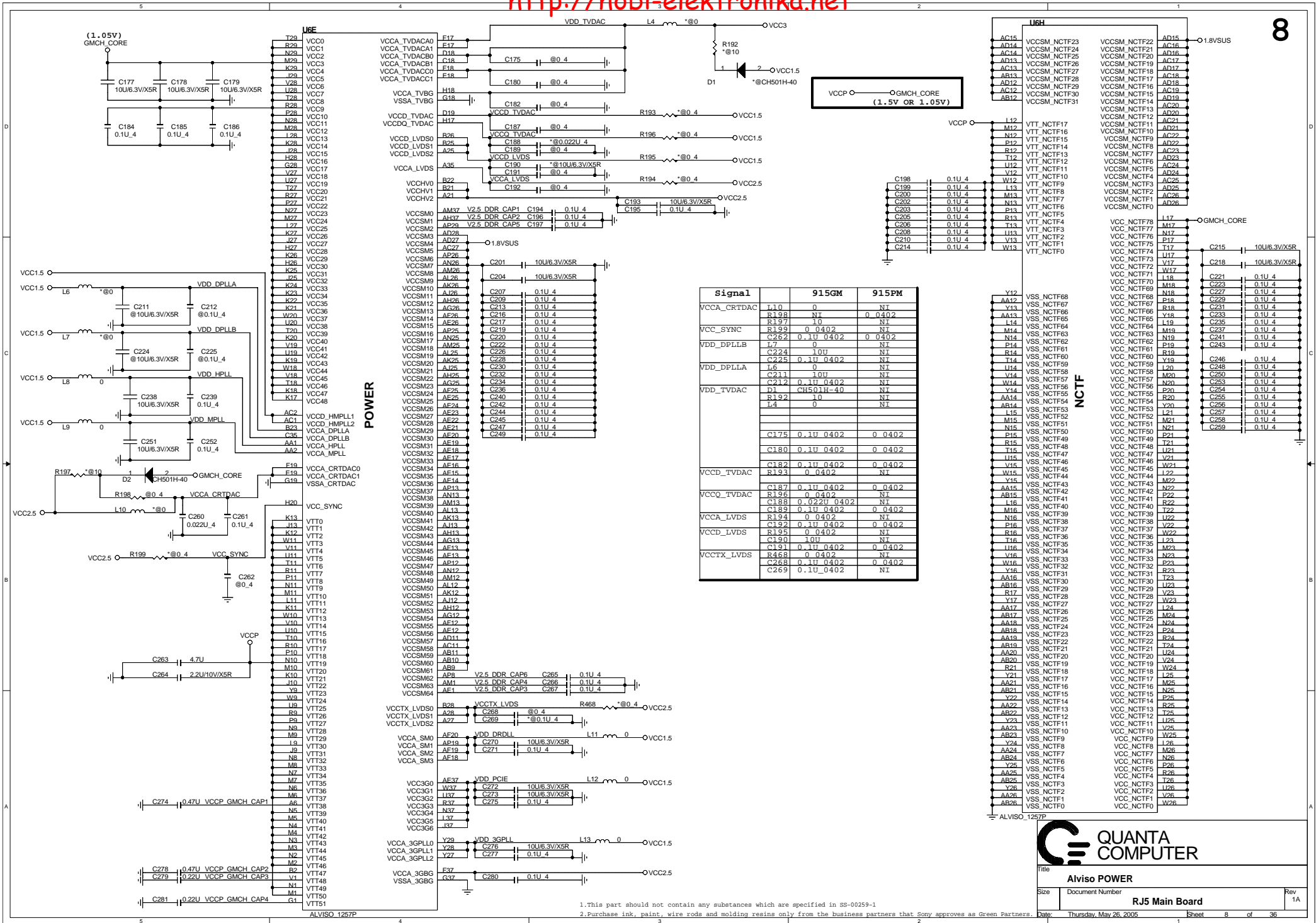

QUANTA COMPUTER

ALVISO POWER

RJ5 Main Board

Rev 1A

Date: Thursday, May 26, 2005

Sheet 8 of 36

1. This part should not contain any substances which are specified in SS-00259-1
 2. Purchase ink, paint, wire rods and molding resins only from the business partners that Sony approves as Green Partners.

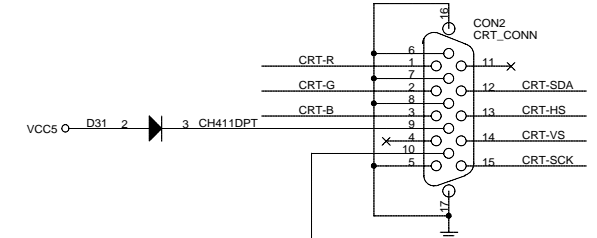
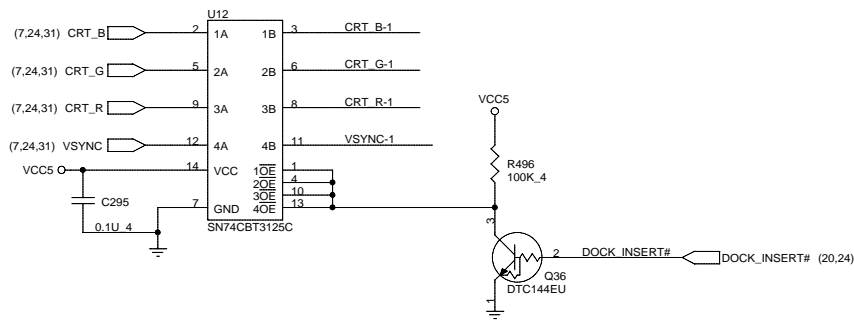
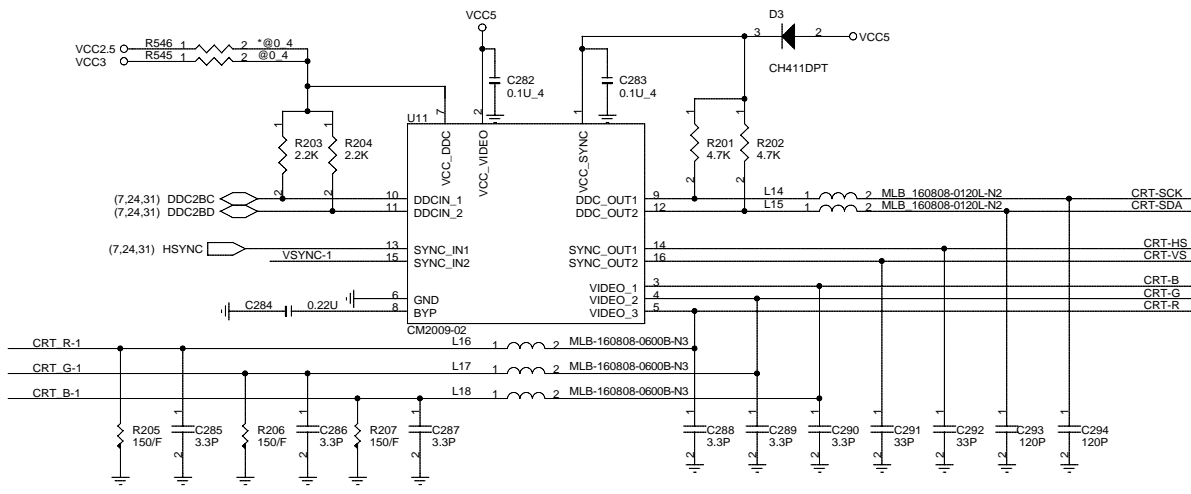

	SENSE_EN#	MB CRT	DOCK CRT	DOCK DVI	CRT_SENSE
All no Plug	L	H	H	L	L
MB CRT Plug	L	L	H	L	H
DOCK CRT Plug	L	H	L	L	H
DOCK DVI Plug	L	H	H	H	H
SENSE EN	H	X	X	X	L
DOCK CRT/DVI Plug	L	H	L	H	L
DOCK CRT/MB CRT Plug	L	L	L	L	L

7SET86FU

A	B	Y
H	H	L
H	L	H
L	H	H
L	L	L

Signal		915GM	915PM
VCC_DDC	R545	NI	0_4
	R546	0_4	NI

QUANTA COMPUTER

Title: CRT

Size: Document Number: Rev 1A

Part Number: RJ5 Main Board

Date: Tuesday, May 10, 2005 Sheet 9 of 36

1. This part should not contain any substances which are specified in SS-00259-1
 2. Purchase ink, paint, wire rods and molding resins only from the business partners that Sony approves as Green Partners.

	H_DPRSTP#	H_SLP#
For Dothan A-X step	*0	0
*For Dothan B-X step & later	0	*0

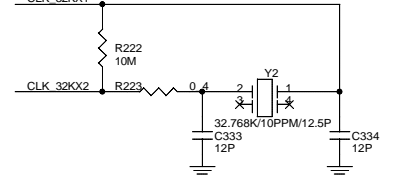
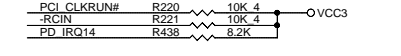
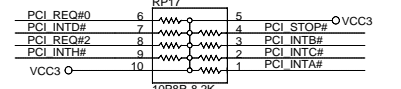
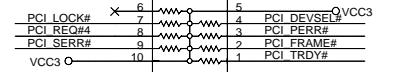
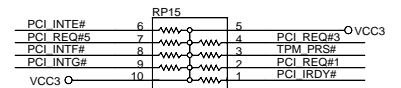

- PCI_REQ0 : TI-7411
- PCI_REQ1 : VT6212
- PCI_REQ2 : SATA(s11 3512)
- PCI_REQ3 : MINI PCI
- PCI_REQ4 : X
- PCI_REQ5 : X
- PCI_REQ6 : X
- IDSEL: (AD16 ~ 29)
- AD24 : SATA(s11 3512)
- AD25 : TI-7411
- AD26 : MINI PCI
- AD27 : VT6212

- PCI_INTA# : VT6212
- PCI_INTB# : SATA(s11 3512)
- PCI_INTC# : MINI PCI
- PCI_INTD# : VT6212
- PCI_INTE# : TI-7411
- PCI_INTF# : TI-7411
- PCI_INTG# : TI-7411, VT6212
- PCI_INTH# : MINI PCI

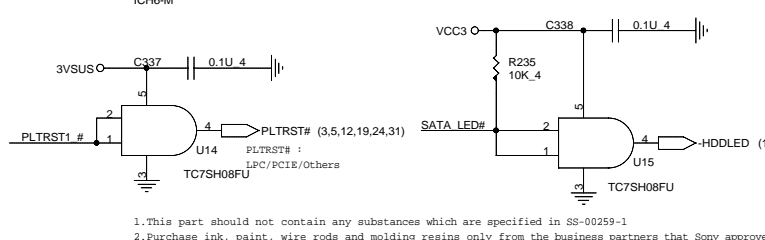
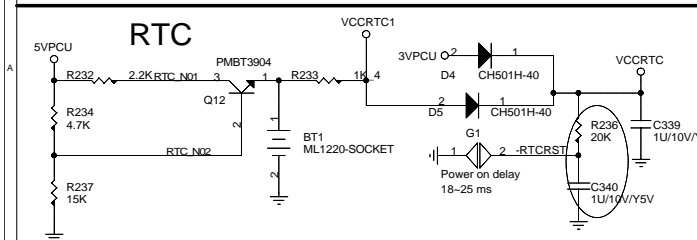
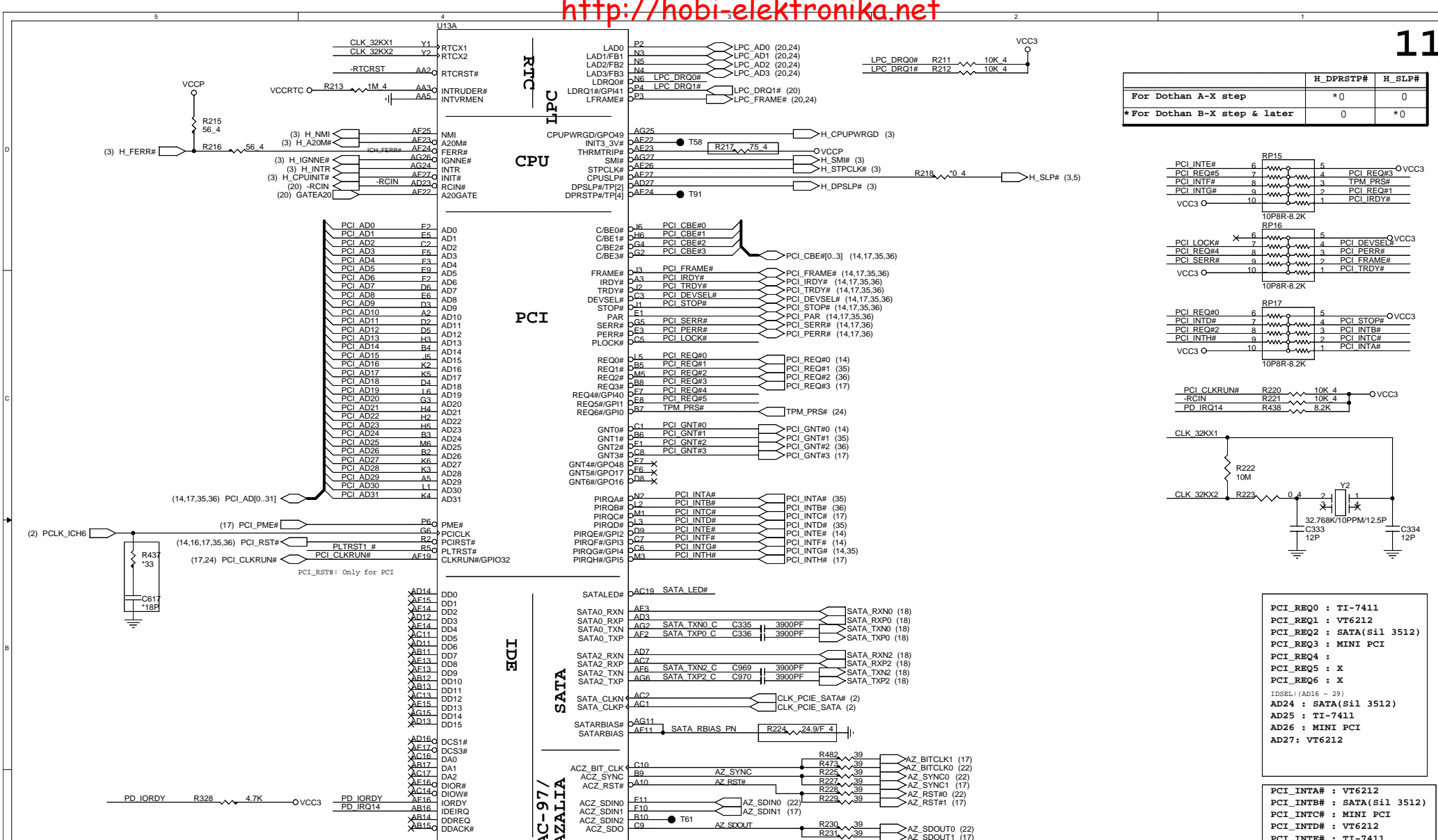

1. This part should not contain any substances which are specified in SS-00259-1
 2. Purchase ink, paint, wire rods and molding resins only from the business partners that Sony approves as Green Partners.

QUANTA COMPUTER

Title: ICH6-M

Size: Document Number

Rev: 1A

Sheet: 11 of 36

Date: Tuesday, May 10, 2005

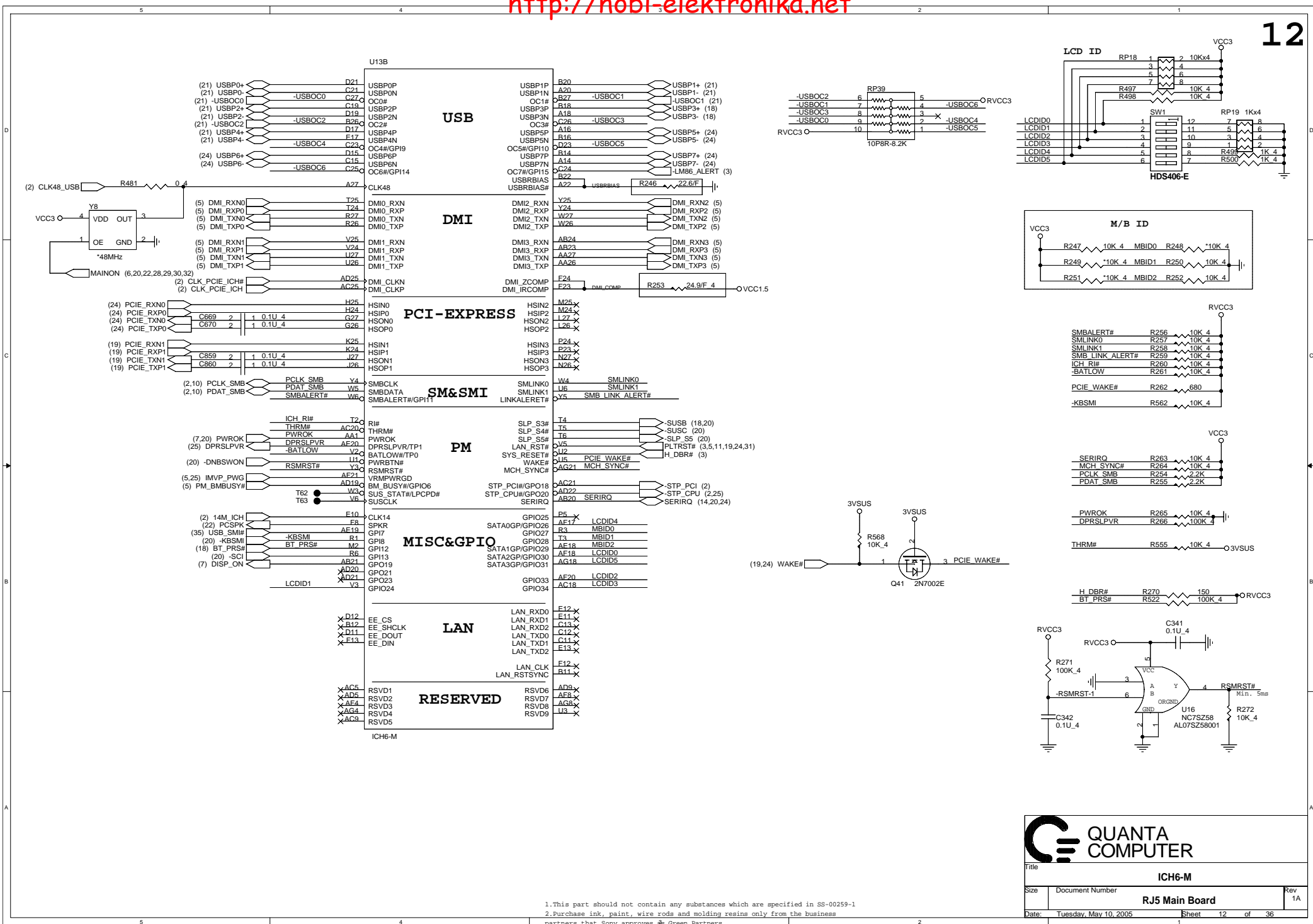

QUANTA COMPUTER

Title: **ICH6-M**

Size: Document Number: Rev 1A

Date: Tuesday, May 10, 2005 Sheet 12 of 36

1. This part should not contain any substances which are specified in SS-00259-1
 2. Purchase ink, paint, wire rods and molding resins only from the business partners that Sony approves & Green Partners.

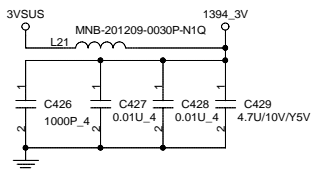
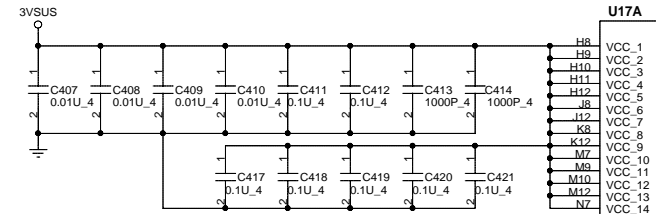

PCI AD31 U2	AD31
PCI AD30 V4	AD30
PCI AD29 V2	AD29
PCI AD28 U5	AD28
PCI AD27 W2	AD27
PCI AD26 V3	AD26
PCI AD25 U4	AD25
PCI AD24 V4	AD24
PCI AD23 V5	AD23
PCI AD22 U5	AD22
PCI AD21 R6	AD21
PCI AD20 R6	AD20
PCI AD19 W6	AD19
PCI AD18 V6	AD18
PCI AD17 U6	AD17
PCI AD16 R7	AD16
PCI AD15 V2	AD15
PCI AD14 U9	AD14
PCI AD13 R9	AD13
PCI AD12 N9	AD12
PCI AD11 V10	AD11
PCI AD10 U10	AD10
PCI AD9 R10	AD9
PCI AD8 N10	AD8
PCI AD7 V11	AD7
PCI AD6 U11	AD6
PCI AD5 R11	AD5
PCI AD4 W12	AD4
PCI AD3 V12	AD3
PCI AD2 U12	AD2
PCI AD1 U14	AD1
PCI AD0 W13	AD0

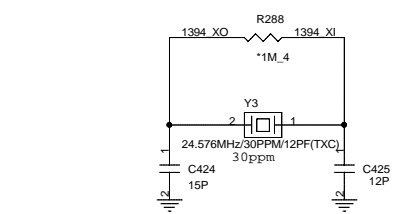
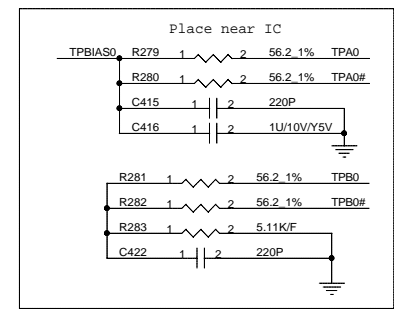
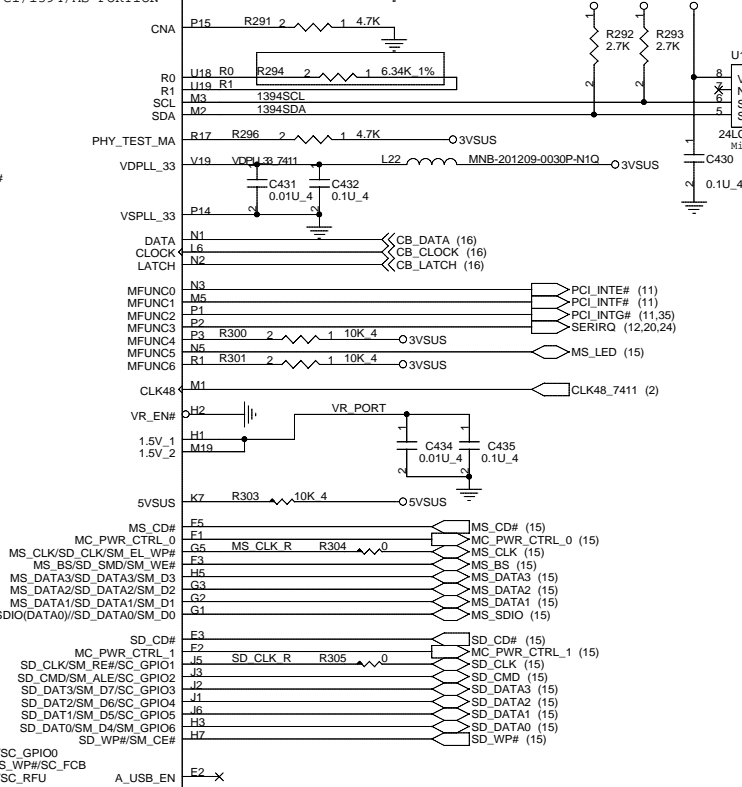
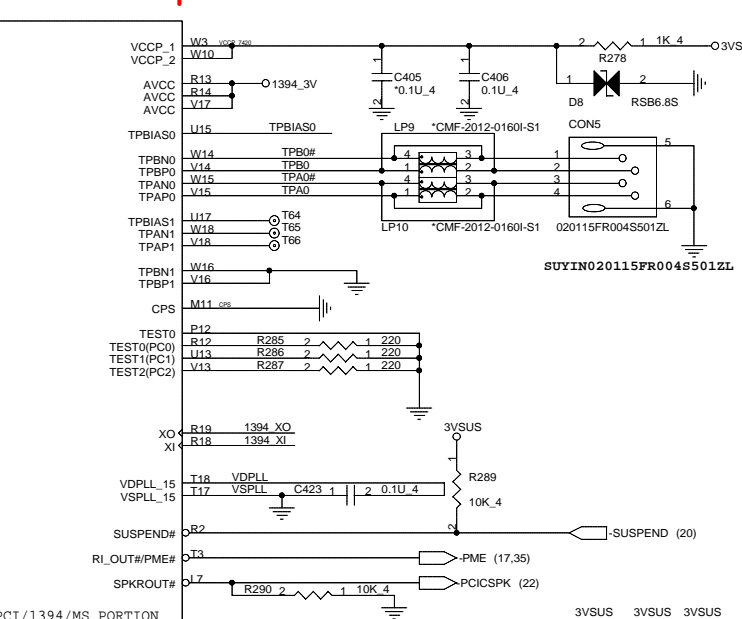
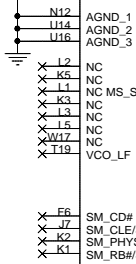
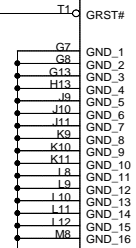
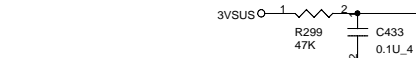
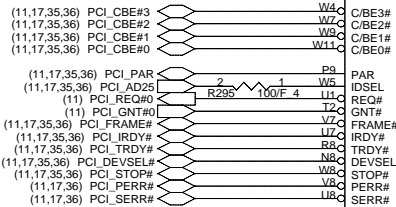

QUANTA COMPUTER

Title: **TI-7411 CardBus Control -- A**

Size: Document Number

Date: Thursday, May 26, 2005

Sheet 14 of 36

Rev 1A

1. This part should not contain any substances which are specified in SS-00259-1
 2. Purchase ink, paint, wire rods and molding resins only from the business partners that Sony approves as Green Partners.

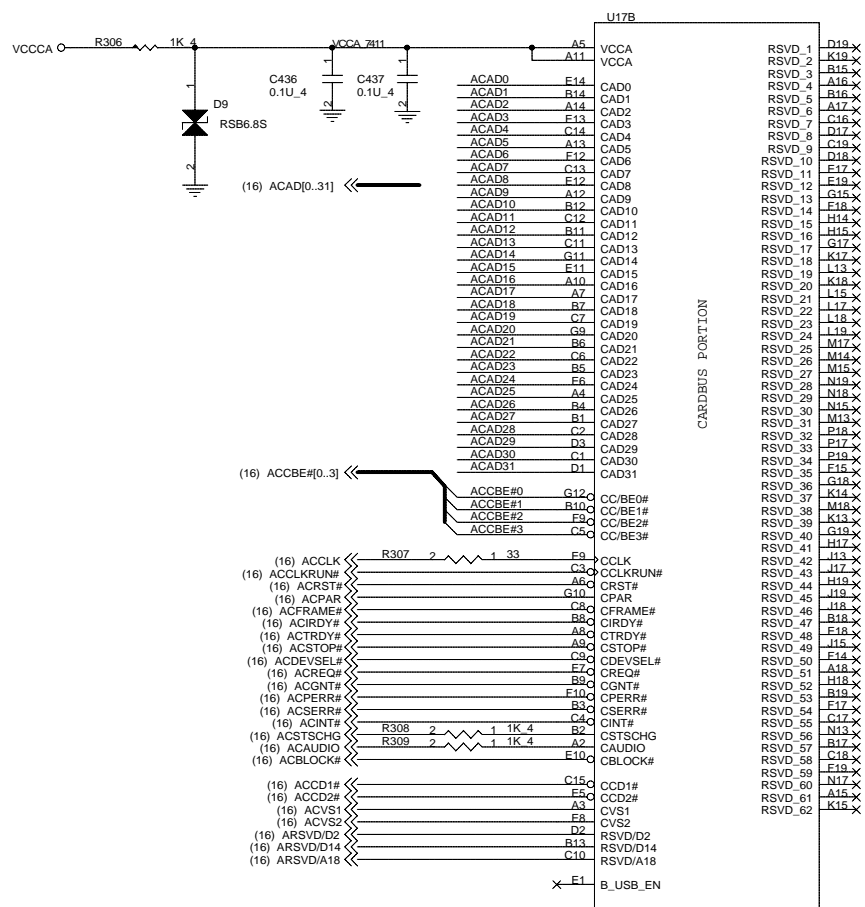

CARDBUS PORTION

TL_7411

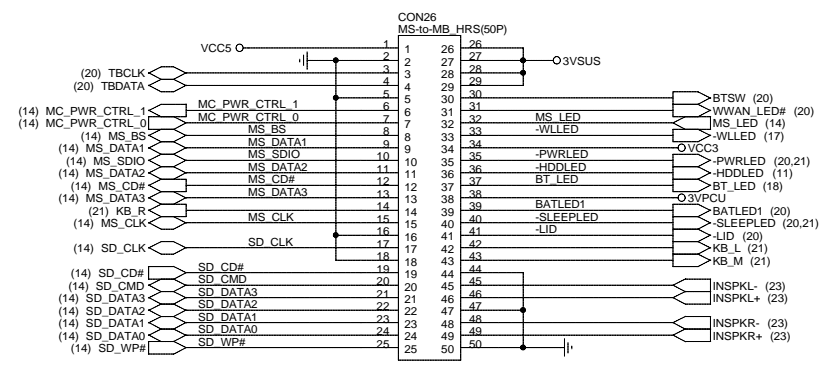

Hiros

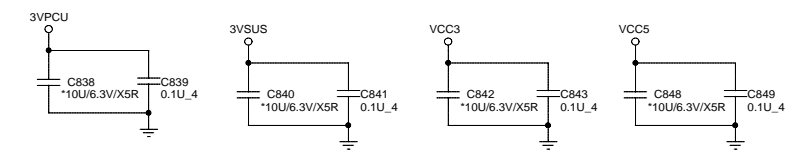

1. This part should not contain any substances which are specified in SS-00259-1
 2. Purchase ink, paint, wire rods and molding resins only from the business partners that Sony approves as Green Partners.

QUANTA COMPUTER

Title: **TI-7411 CardBus Control -- B**

Size: Document Number Rev 1A

Date: Thursday, May 26, 2005 Sheet 15 of 36

(15) ACAD[0..31] <<<
(15) ACCBE#[0..3] <<<

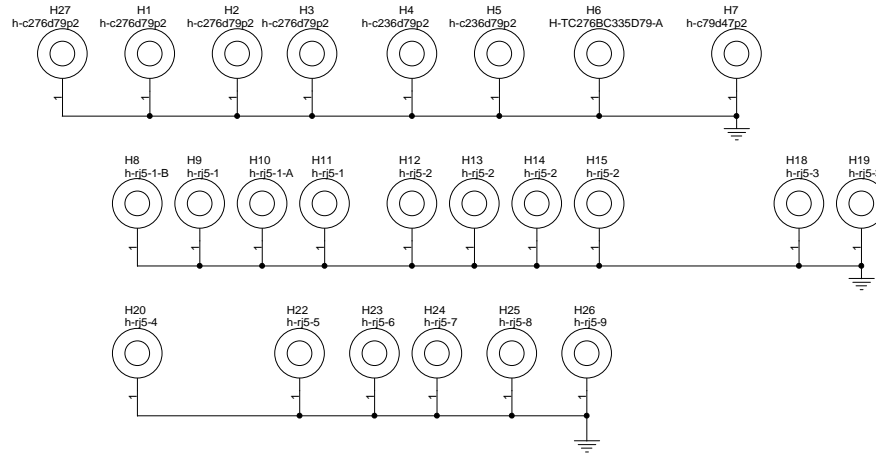
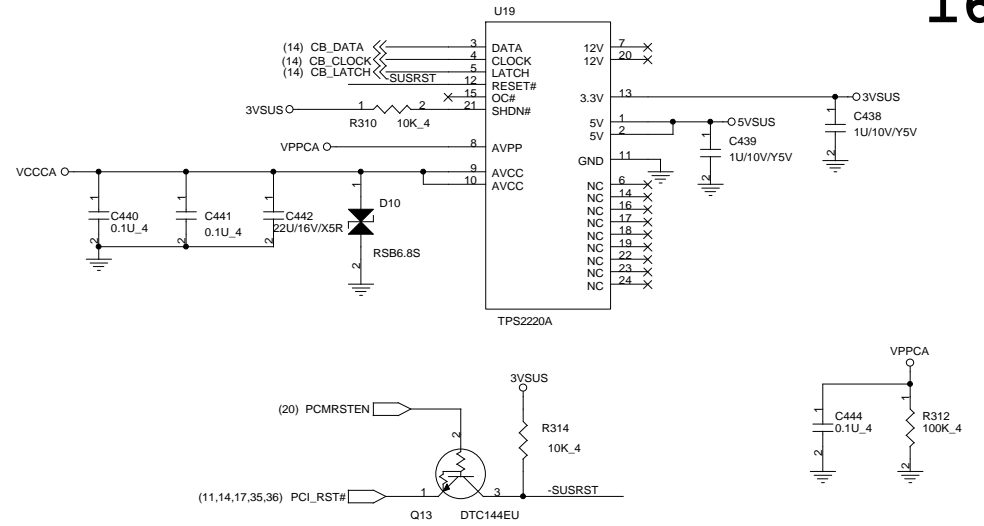
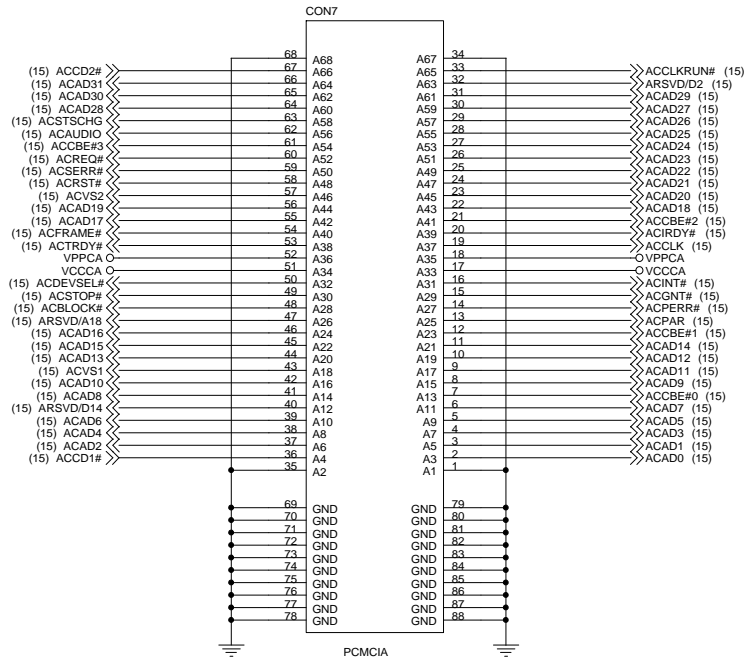

QUANTA COMPUTER logo and title block containing: Title: CARDBUS SLOT, Size: Document Number, Rev: 1A, Date: Thursday, May 26, 2005, Sheet: 16 of 36.

1. This part should not contain any substances which are specified in SS-00259-1
2. Purchase ink, paint, wire rods and molding resins only from the business partners that Sony approves as Green Partners.

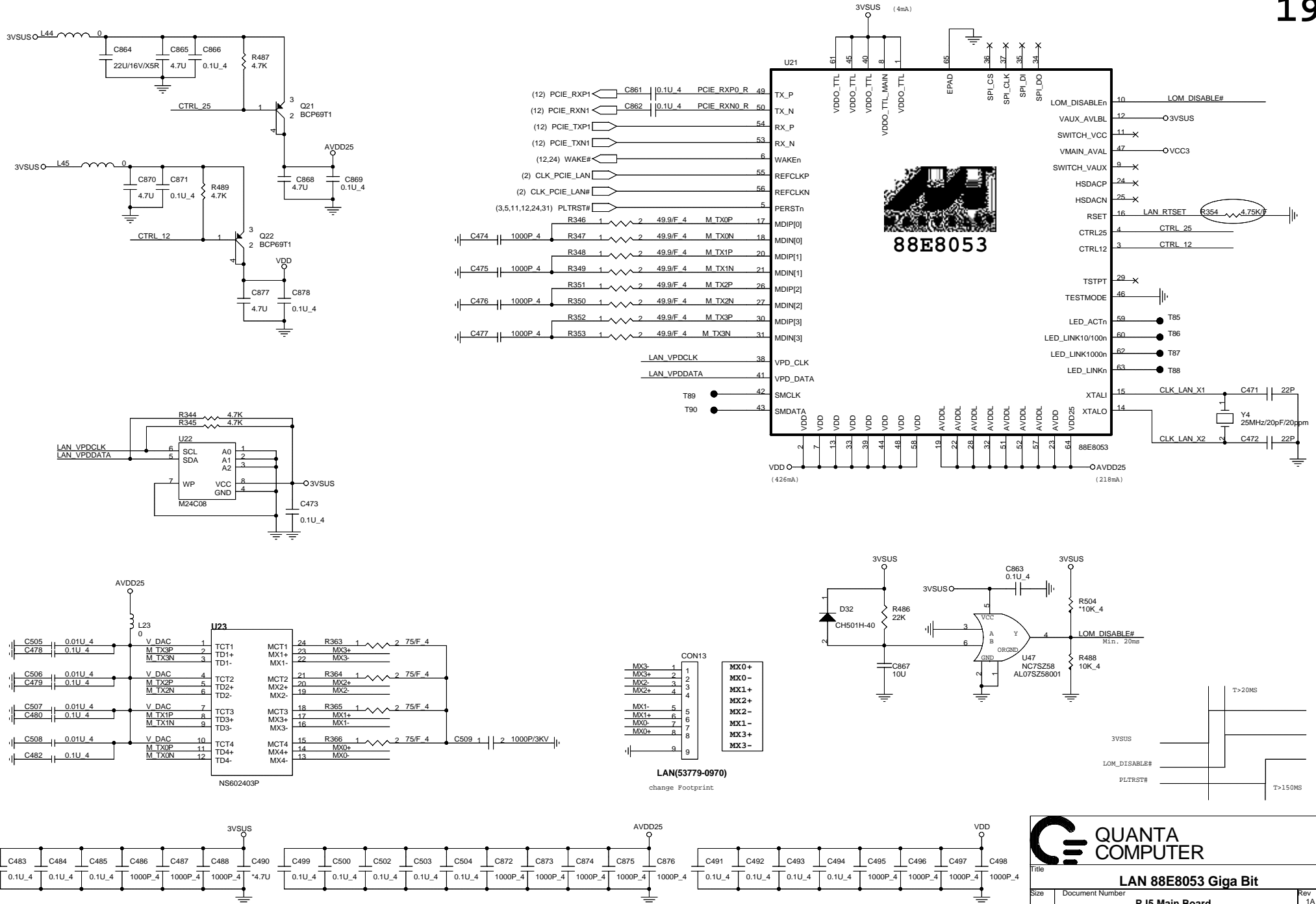

QUANTA COMPUTER

Title: **LAN 88E8053 Giga Bit**

Size: Document Number

Rev: **1A**

Date: Thursday, May 26, 2005

Sheet: 19 of 36

1. This part should not contain any substances which are specified in SS-00259-1
 2. Purchase ink, paint, wire rods and molding resins only from the business partners that Sony approves as Green Partners.

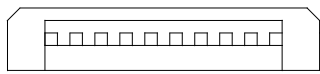

KEYBOARD

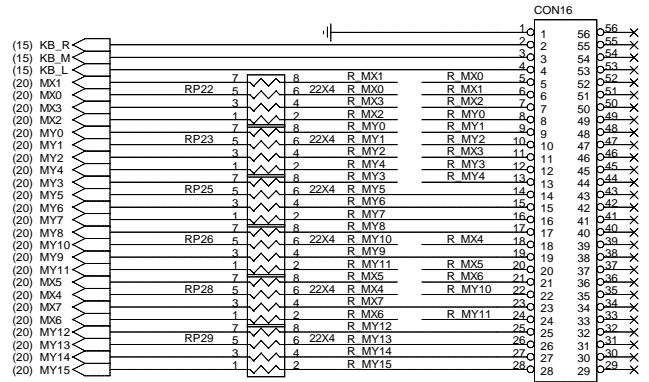

MOLEX(52610-2871)

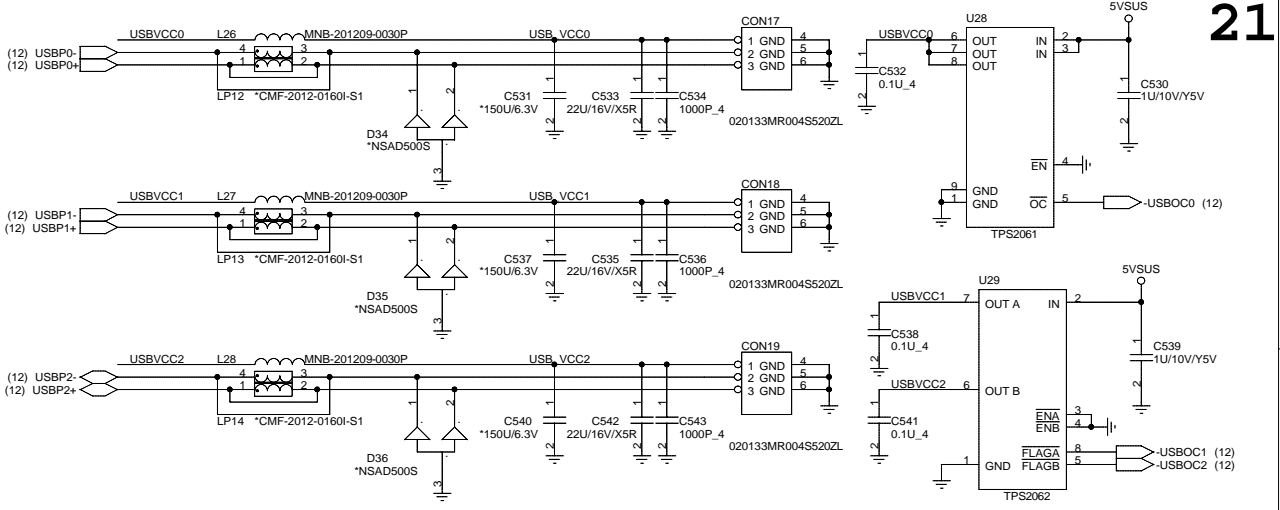

POWER SW BOARD

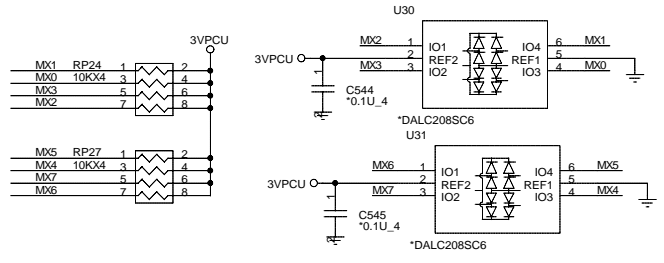

USB Camera

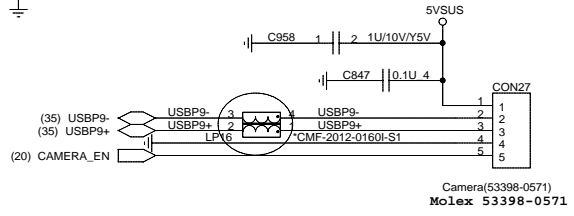

Camera(53398-0571)
Molex 53398-0571

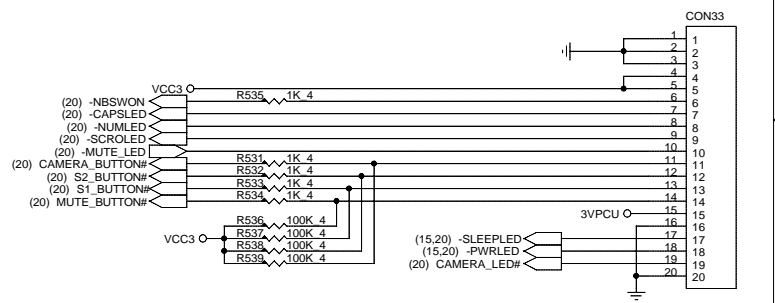

PS CON(52559-2070)
Molex_52559-2070

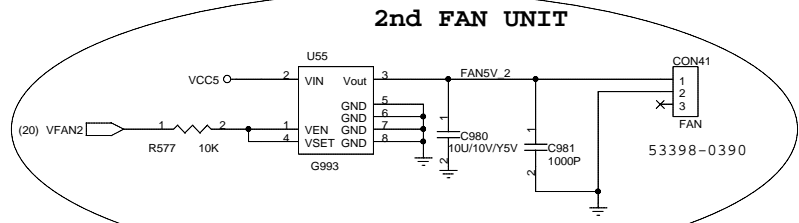

2nd FAN UNIT

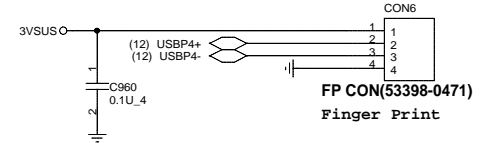

FP CON(53398-0471)
Finger Print



1. This part should not contain any substances which are specified in SS-00259-1
 2. Purchase ink, paint, wire rods and molding resins only from the business partners that Sony approves as Green Partners.

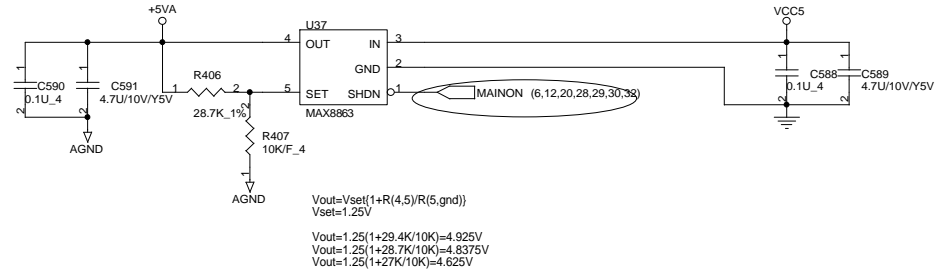
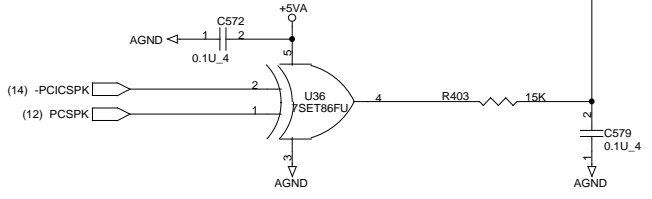
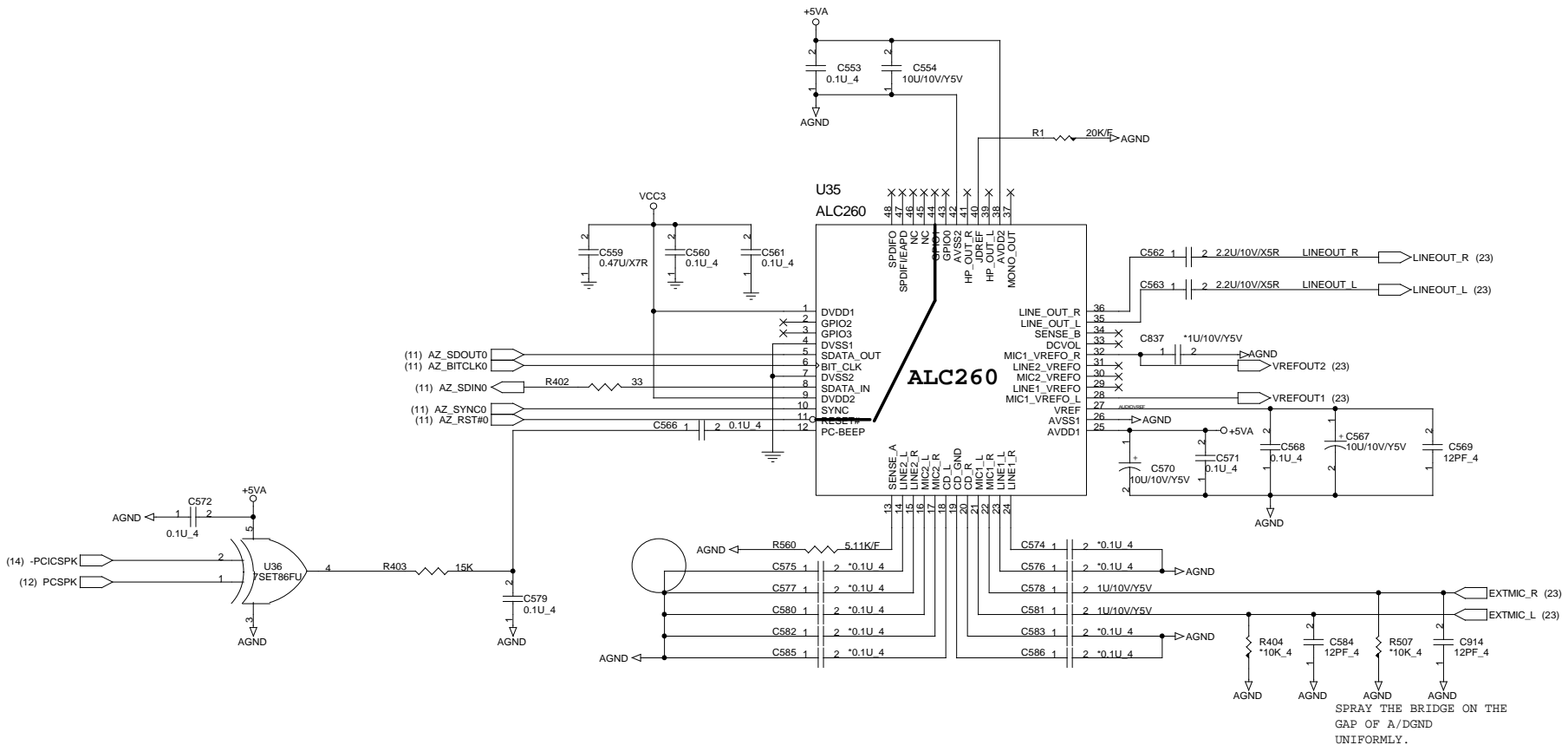

SPRAY THE BRIDGE ON THE GAP OF A/DGND UNIFORMLY.

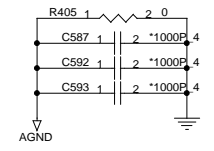

Title		
Audio ALC260		
Size	Document Number	Rev
	RJ5 Audio Board	1A

Audio amplifier

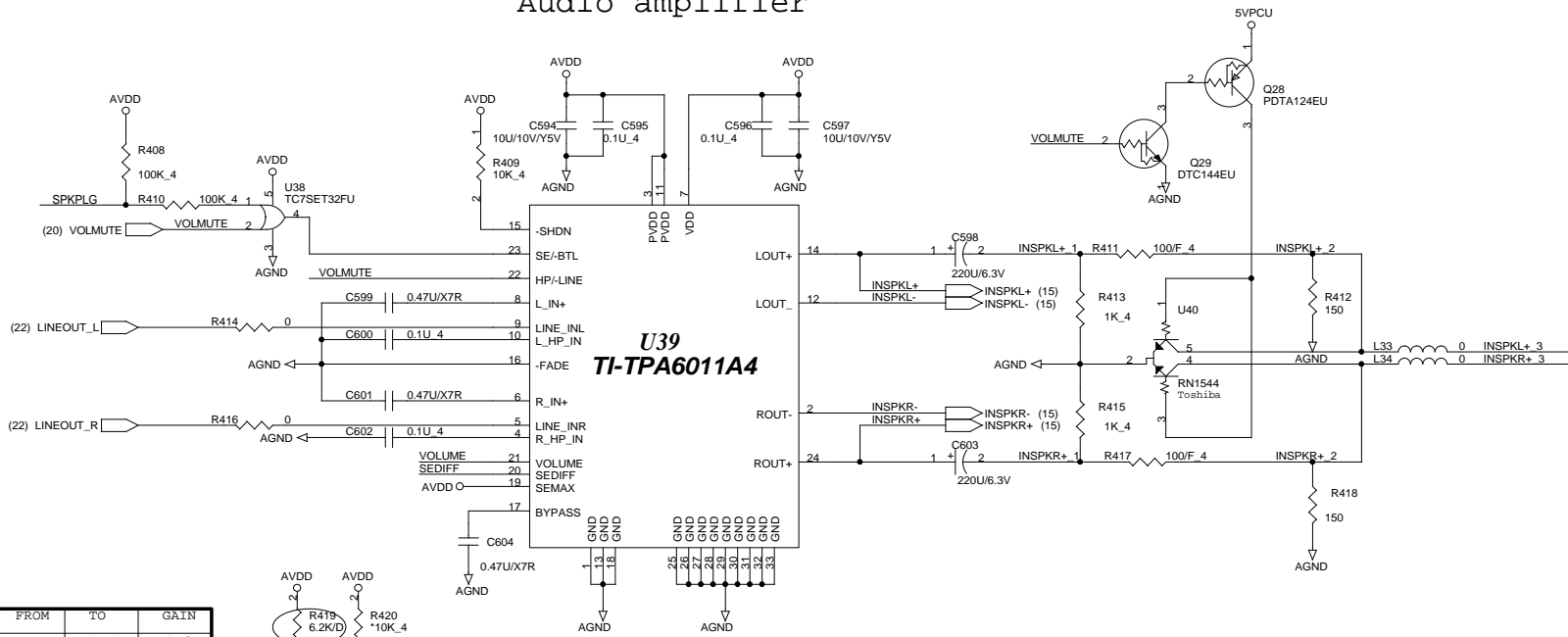

FROM	TO	GAIN
2.92	2.95	6 dB
3.04	3.06	8 dB
3.15	3.17	10 dB
3.26	3.29	12 dB

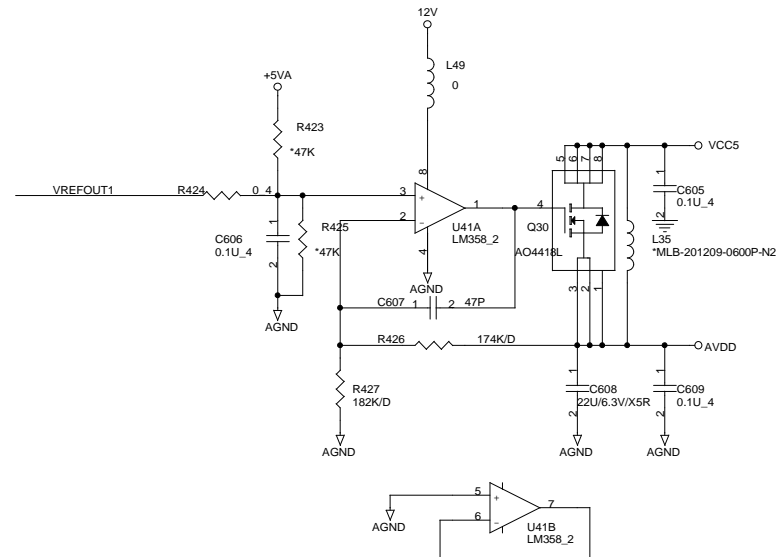
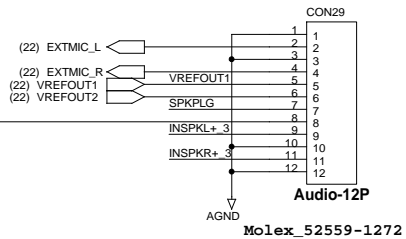
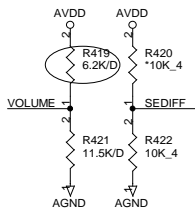

QUANTA COMPUTER

Title: **AUDIO AMP**

Size: _____ Document Number: **RJ5 Audio Board** Rev 1A

Date: Thursday, May 26, 2005 Sheet 23 of 36

1. This part should not contain any substances which are specified in SS-00259-1
 2. Purchase ink, paint, wire rods and molding resins only from the business partners that Sony approves as Green Partners.

Docking

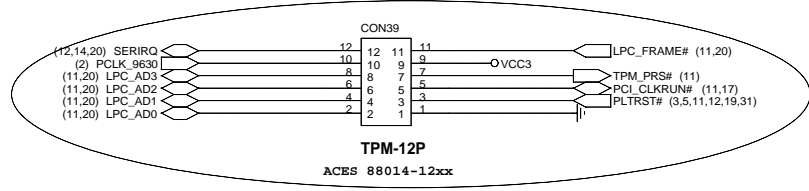
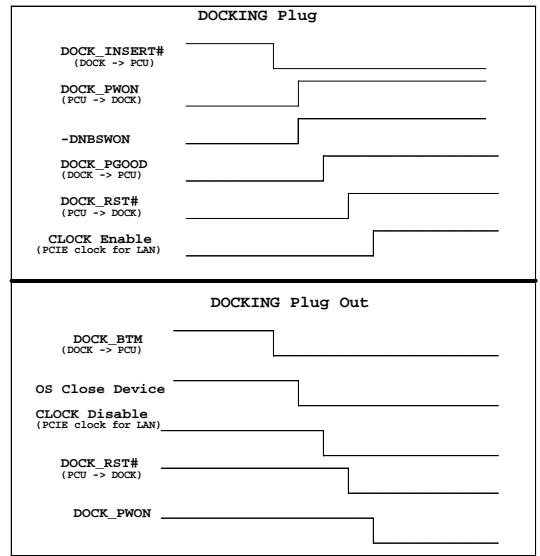
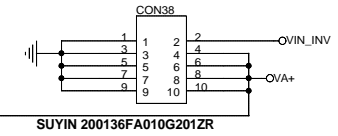
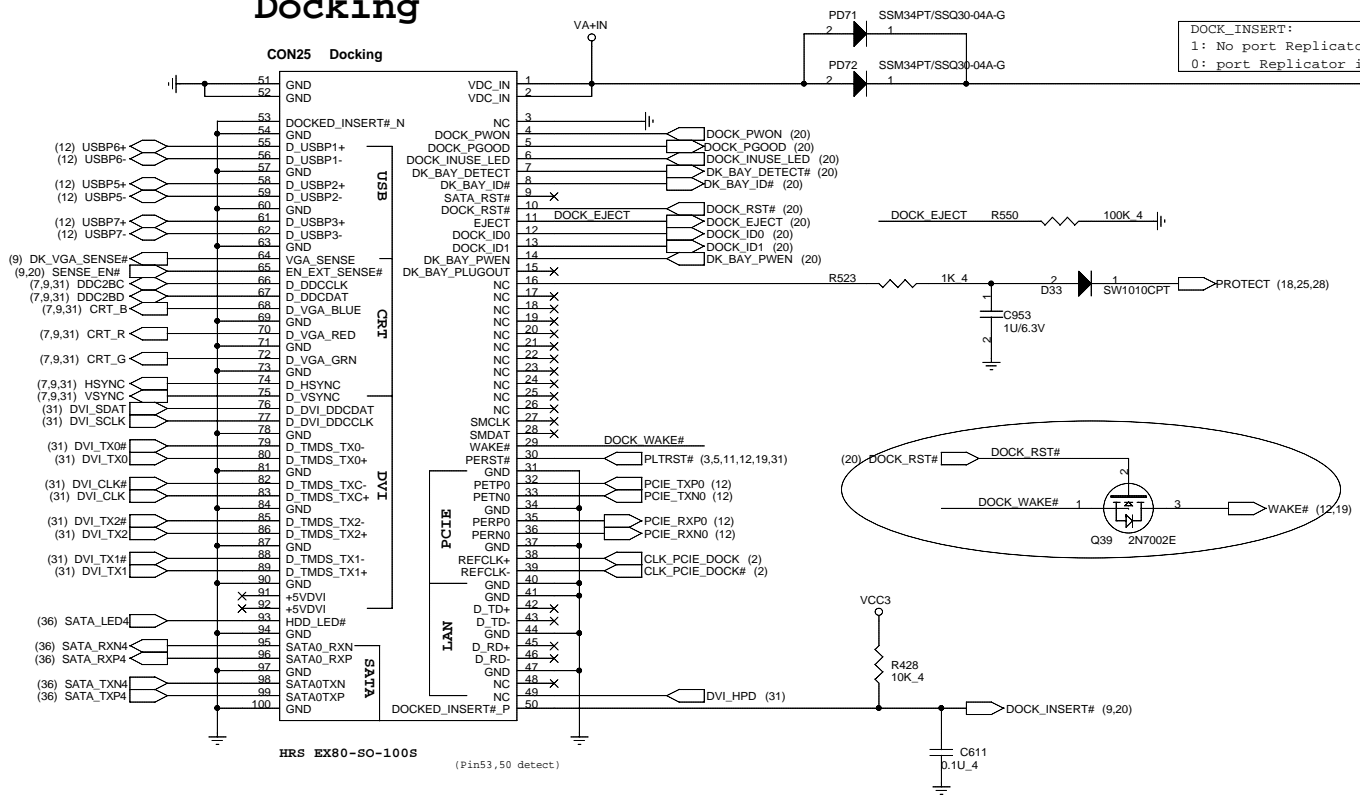

1. This part should not contain any substances which are specified in SS-00259-1
 2. Purchase ink, paint, wire rods and molding resins only from the business partners that Sony approves as Green Partners.

QUANTA COMPUTER

Title: **Docking/TPM**

Size: Document Number: **RJ5 Main Board** Rev 1A

Date: Tuesday, May 10, 2005 Sheet 24 of 36

CPU CORE

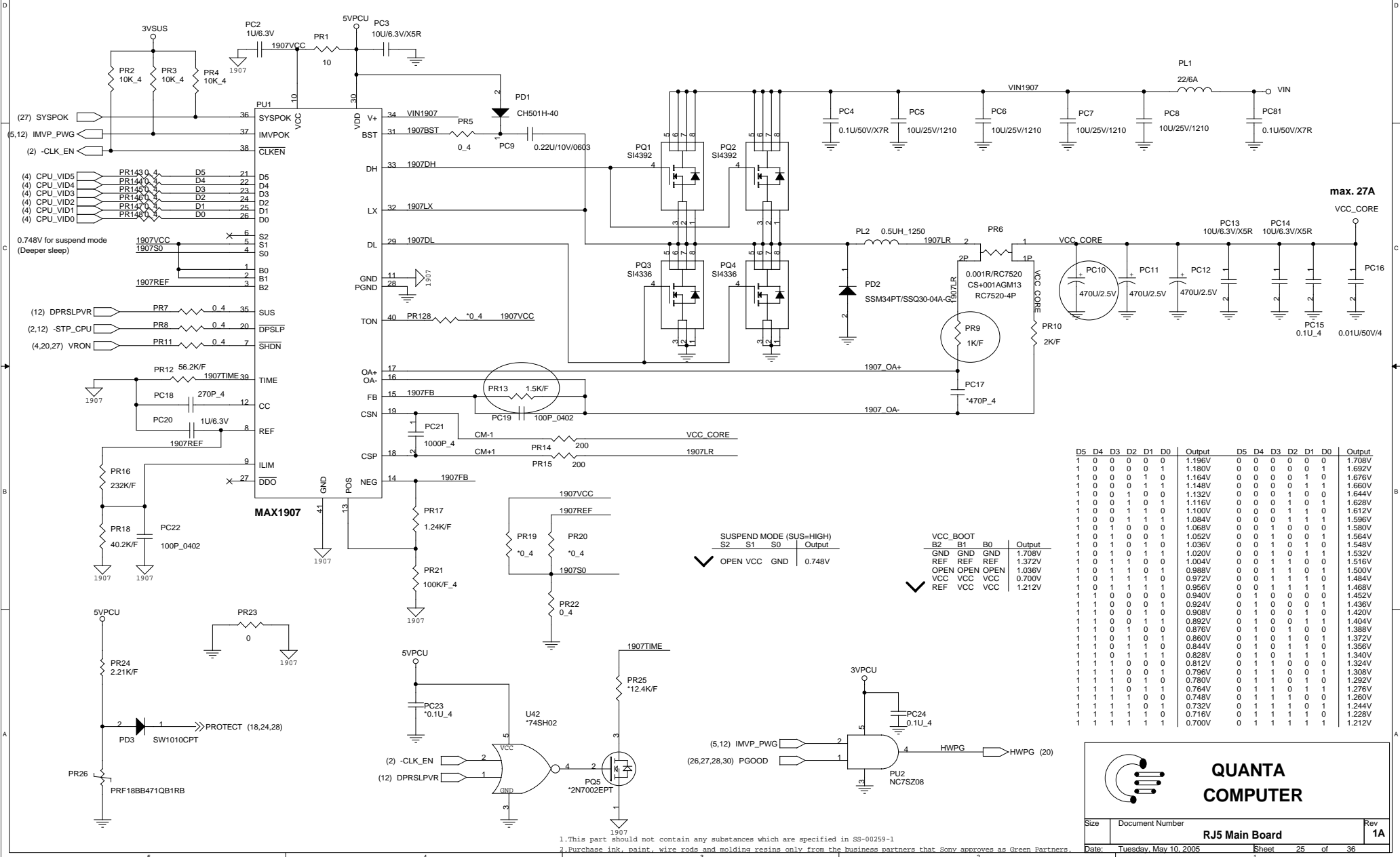

D5	D4	D3	D2	D1	D0	Output	D5	D4	D3	D2	D1	D0	Output
1	0	0	0	0	0	1.196V	0	0	0	0	0	0	1.708V
1	0	0	0	0	1	1.180V	0	0	0	0	0	1	1.692V
1	0	0	0	1	0	1.164V	0	0	0	0	1	0	1.676V
1	0	0	0	1	1	1.148V	0	0	0	0	1	1	1.660V
1	0	0	1	0	0	1.132V	0	0	0	1	0	0	1.644V
1	0	0	1	0	1	1.116V	0	0	0	1	0	1	1.628V
1	0	0	1	1	0	1.100V	0	0	0	1	1	0	1.612V
1	0	0	1	1	1	1.084V	0	0	0	1	1	1	1.596V
1	0	1	0	0	0	1.068V	0	0	1	0	0	0	1.580V
1	0	1	0	0	1	1.052V	0	0	1	0	0	1	1.564V
1	0	1	0	1	0	1.036V	0	0	1	0	1	0	1.548V
1	0	1	0	1	1	1.020V	0	0	1	0	1	1	1.532V
1	0	1	1	0	0	1.004V	0	0	1	1	0	0	1.516V
1	0	1	1	0	1	0.988V	0	0	1	1	0	1	1.500V
1	0	1	1	1	0	0.972V	0	0	1	1	1	0	1.484V
1	0	1	1	1	1	0.956V	0	0	1	1	1	1	1.468V
1	1	0	0	0	0	0.940V	0	1	0	0	0	0	1.452V
1	1	0	0	0	1	0.924V	0	1	0	0	1	0	1.436V
1	1	0	0	1	0	0.908V	0	1	0	0	1	1	1.420V
1	1	0	0	1	1	0.892V	0	1	0	0	1	1	1.404V
1	1	0	1	0	0	0.876V	0	1	0	1	0	0	1.388V
1	1	0	1	0	1	0.860V	0	1	0	1	0	1	1.372V
1	1	0	1	1	0	0.844V	0	1	0	1	1	0	1.356V
1	1	0	1	1	1	0.828V	0	1	0	1	1	1	1.340V
1	1	1	0	0	0	0.812V	0	1	1	0	0	0	1.324V
1	1	1	0	0	1	0.796V	0	1	1	0	0	1	1.308V
1	1	1	0	1	0	0.780V	0	1	1	0	1	0	1.292V
1	1	1	0	1	1	0.764V	0	1	1	0	1	1	1.276V
1	1	1	1	0	0	0.748V	0	1	1	1	0	0	1.260V
1	1	1	1	0	1	0.732V	0	1	1	1	0	1	1.244V
1	1	1	1	1	0	0.716V	0	1	1	1	1	0	1.228V
1	1	1	1	1	1	0.700V	0	1	1	1	1	1	1.212V

QUANTA COMPUTER

Size: _____ Document Number: **RJ5 Main Board** Rev: **1A**

Date: Tuesday, May 10, 2005 Sheet 25 of 36

1. This part should not contain any substances which are specified in SS-00259-1
 2. Purchase ink, paint, wire rods and molding resins only from the business partners that Sony approves as Green Partners.

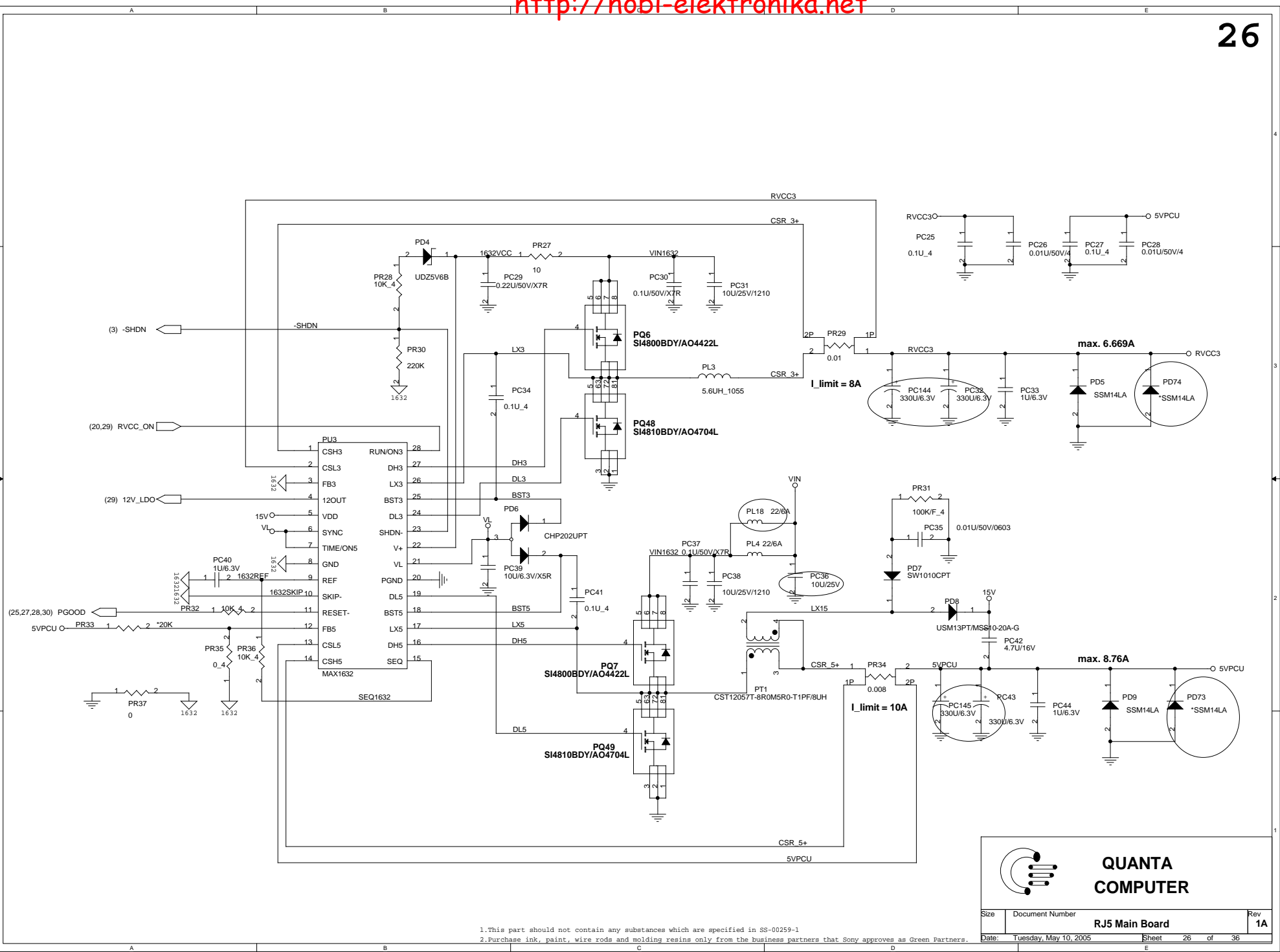

**QUANTA
COMPUTER**

Size	Document Number	RJ5 Main Board	Rev
			1A
Date:	Tuesday, May 10, 2005	Sheet	26 of 36

1. This part should not contain any substances which are specified in SS-00259-1
 2. Purchase ink, paint, wire rods and molding resins only from the business partners that Sony approves as Green Partners.

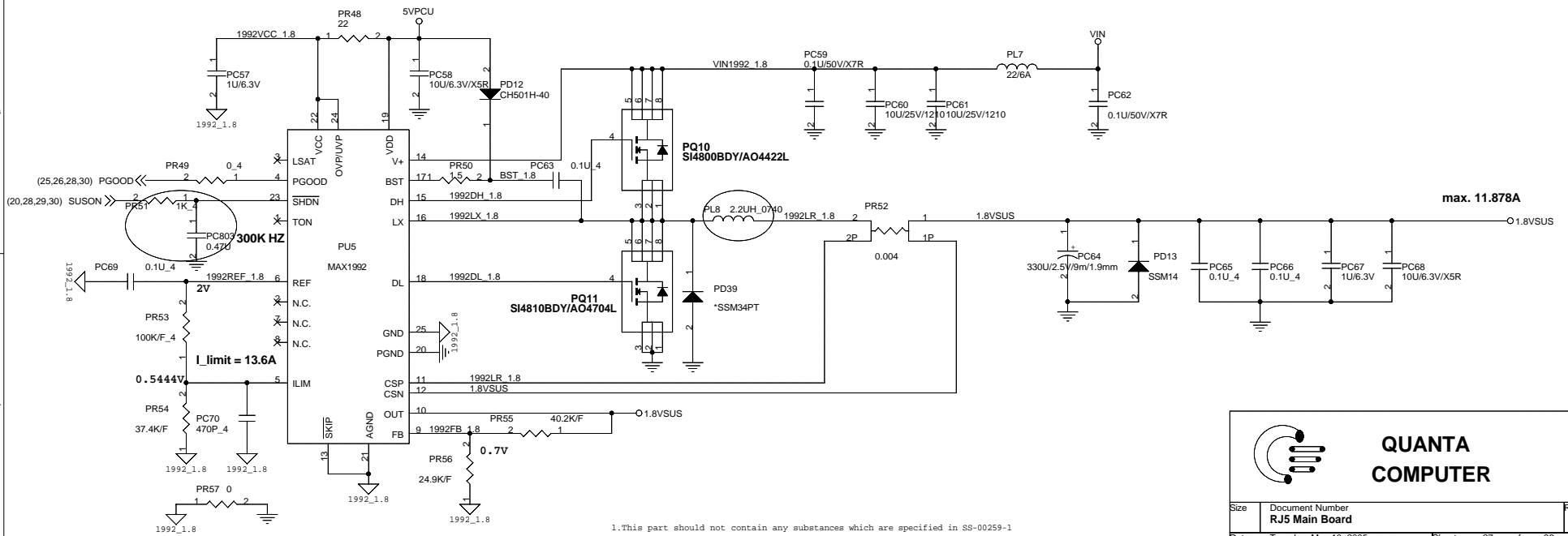
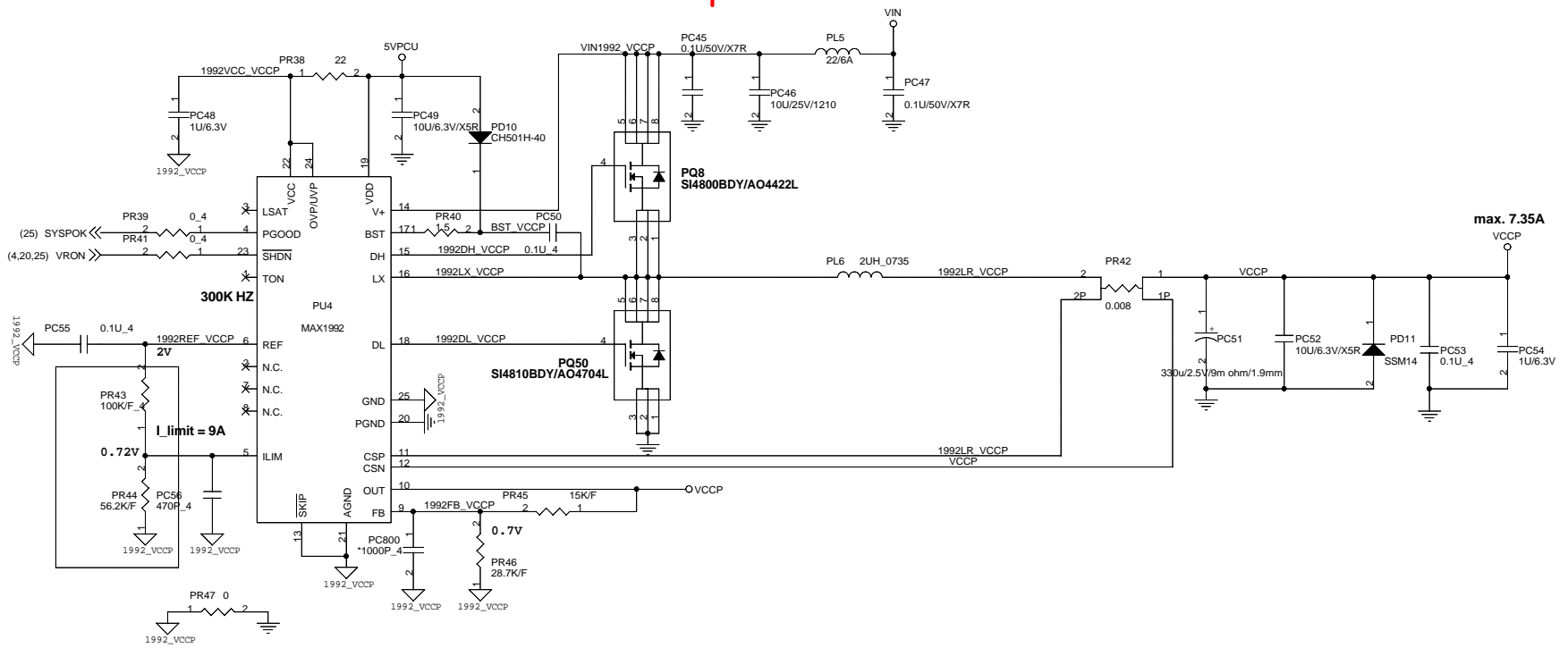

QUANTA COMPUTER

Size	Document Number	Rev
	RJ5 Main Board	1A
Date:	Tuesday, May 10, 2005	Sheet 27 of 36

1. This part should not contain any substances which are specified in SS-00259-1
 2. Purchase ink, paint, wire rods and molding resins only from the business partners that Sony approves as Green Partners.

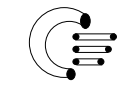
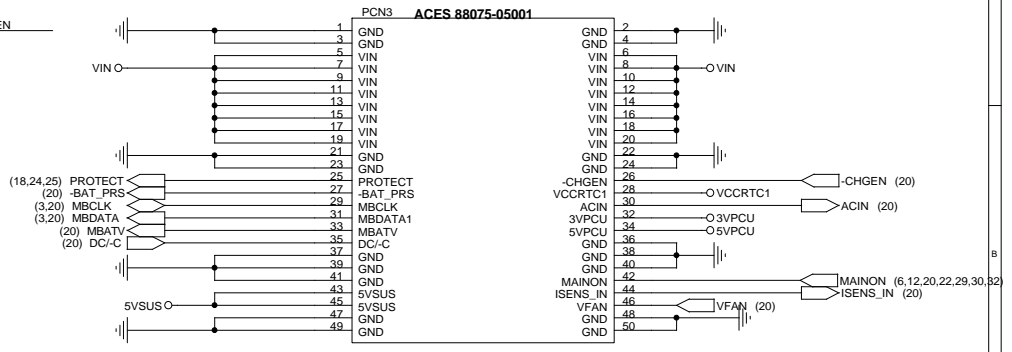
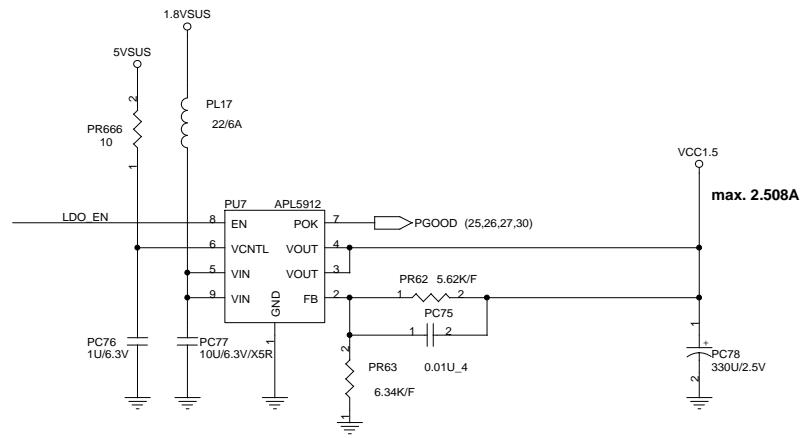
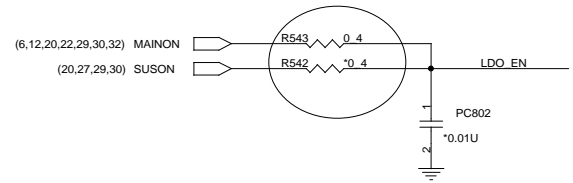
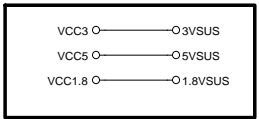
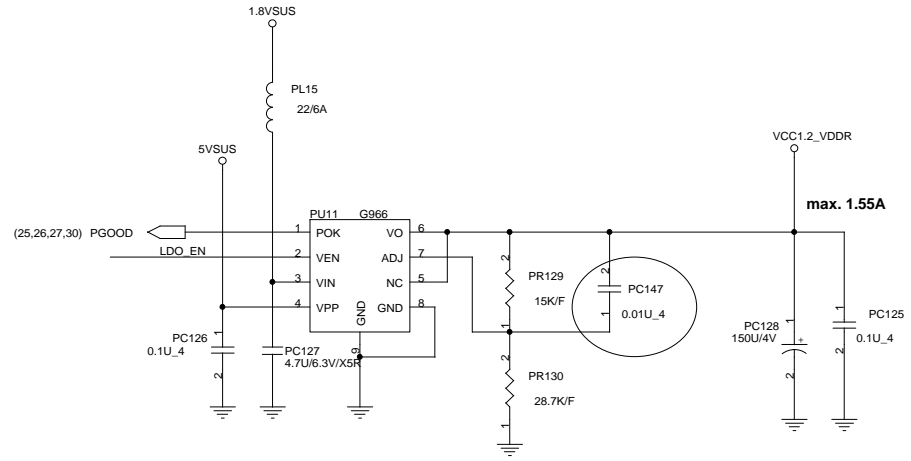
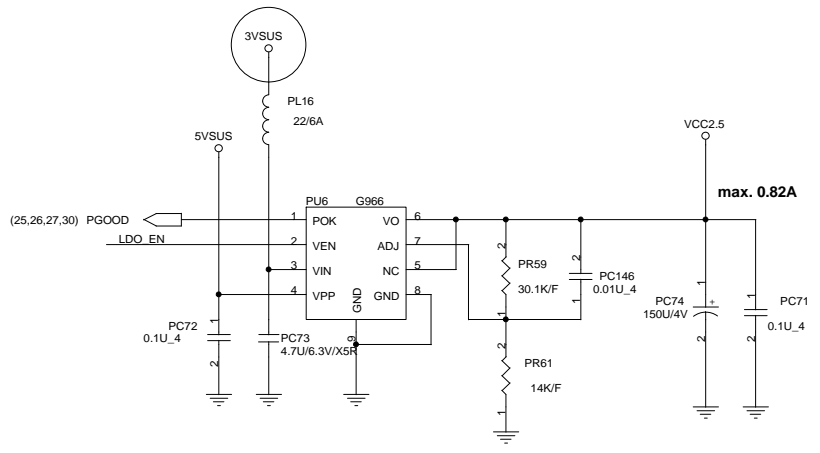

**QUANTA
COMPUTER**

Size	Document Number	Rev
	RJ5 Main Board	1A
Date:	Tuesday, May 10, 2005	Sheet 28 of 36

1. This part should not contain any substances which are specified in SS-00259-1
 2. Purchase ink, paint, wire rods and molding resins only from the business partners that Sony approves as Green Partners.

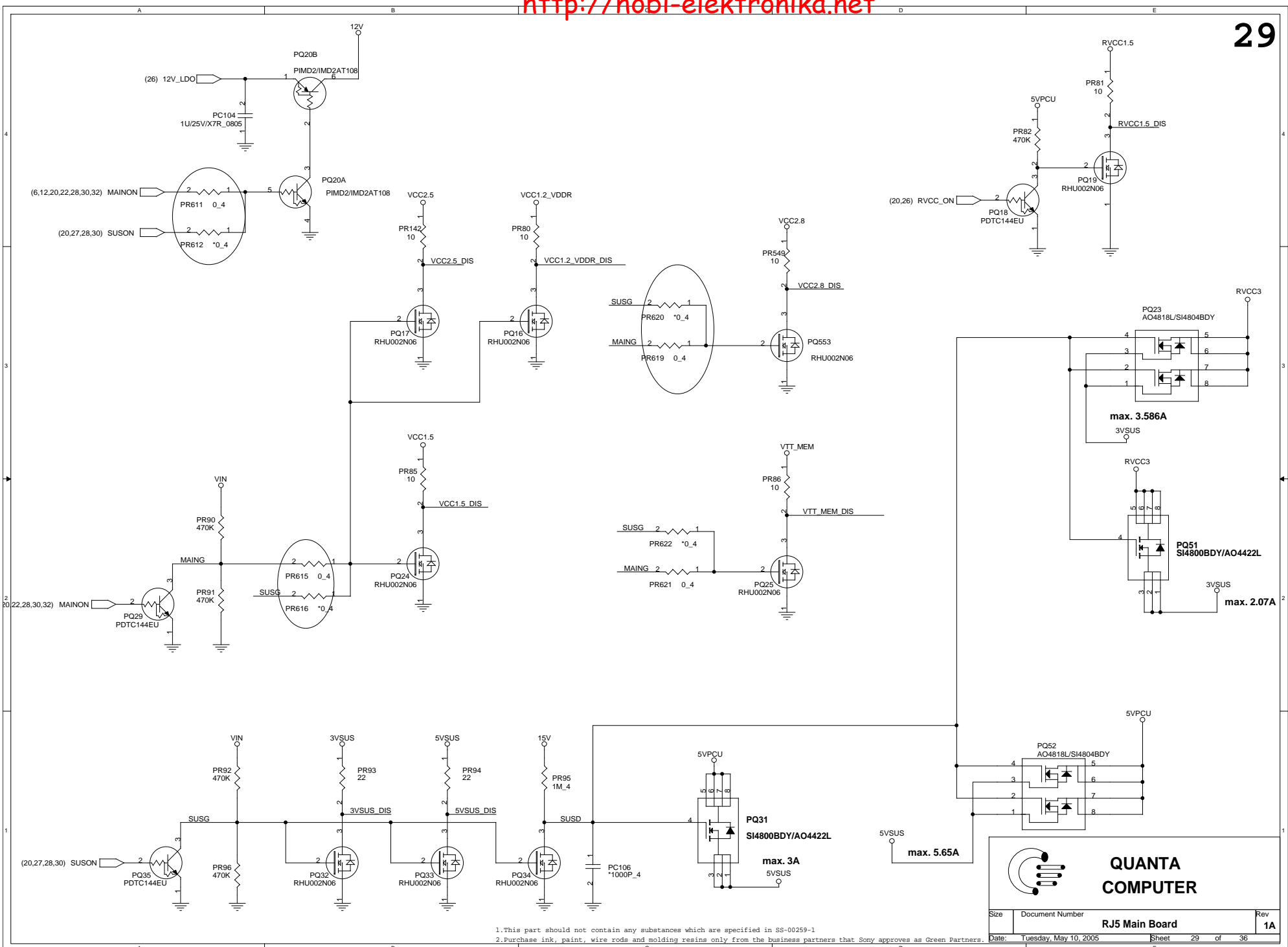

QUANTA COMPUTER

Size: Document Number: **RJ5 Main Board** Rev: **1A**

Date: Tuesday, May 10, 2005 Sheet 29 of 36

1. This part should not contain any substances which are specified in SS-00259-1
 2. Purchase ink, paint, wire rods and molding resins only from the business partners that Sony approves as Green Partners.

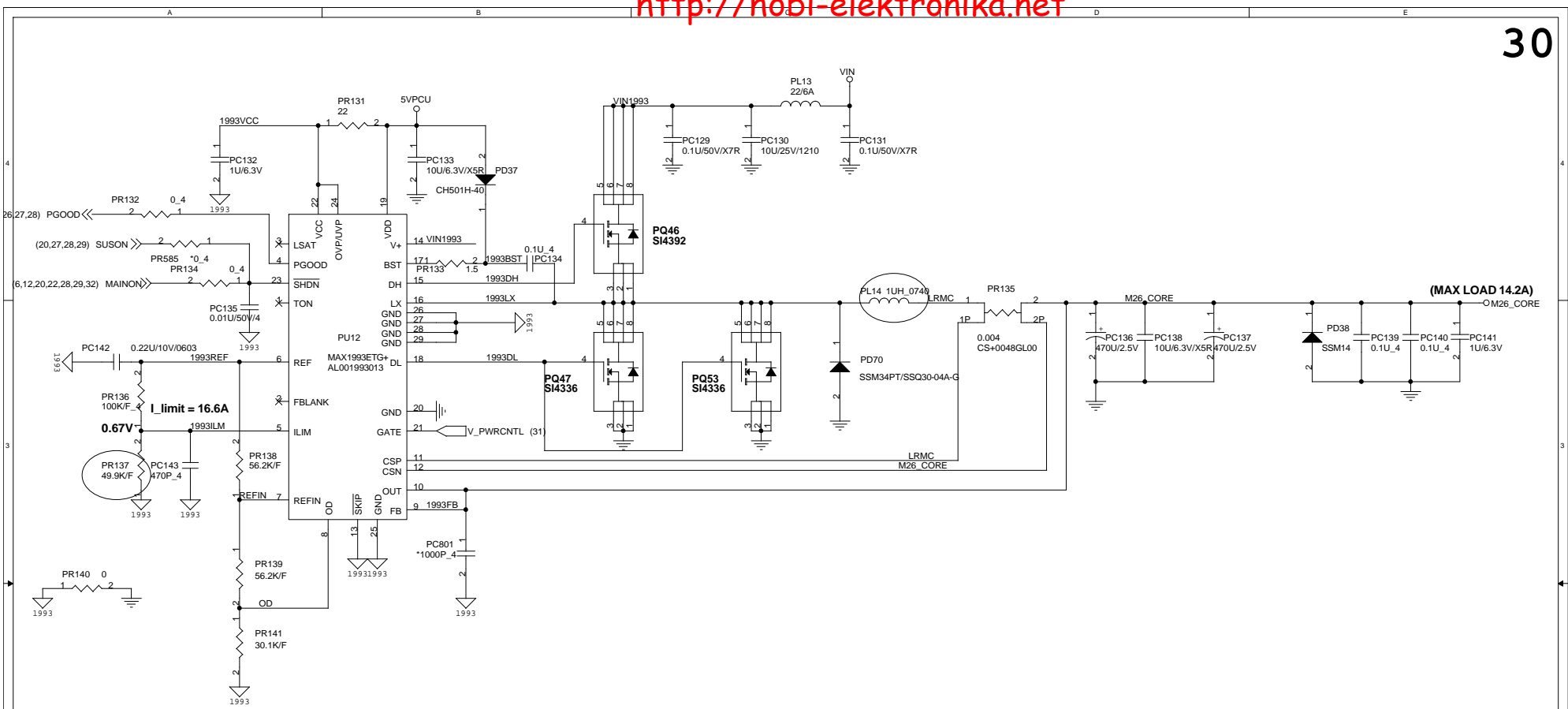

M24_CORE voltage setting:

	PR138 Value	PR139 Value	PR141 Value	V_PWRCNTL	
				Low	High
M24	49.9 K/F	49.9 K/F	27.4 K/F	1.215V	1V
	56.2 K/F	56.2 K/F	30.1 K/F	1.211V	1V

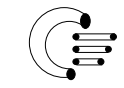

**QUANTA
COMPUTER**

1.This part should not contain any substances which are specified in SS-00259-1.
2.Purchase ink, paint, wire rods and molding resins only from the business partners that Sony approves as Green Partners.

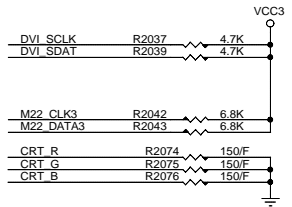
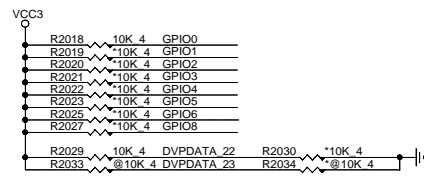
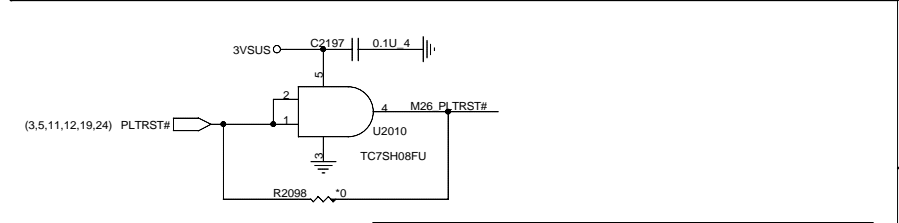
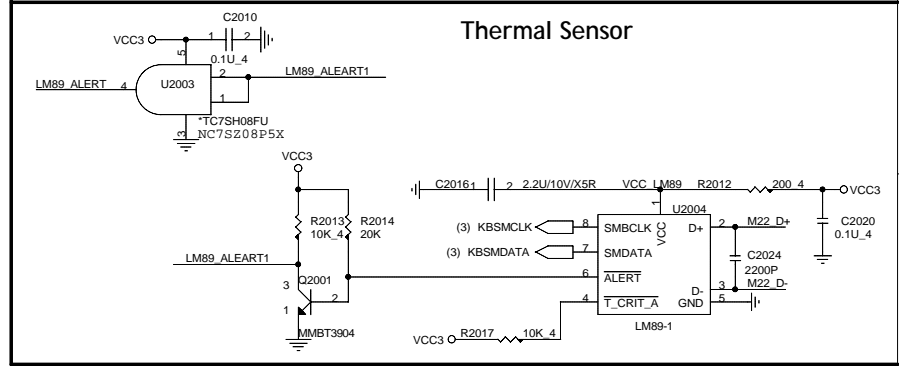
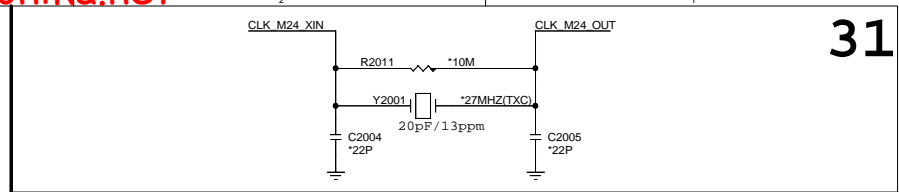
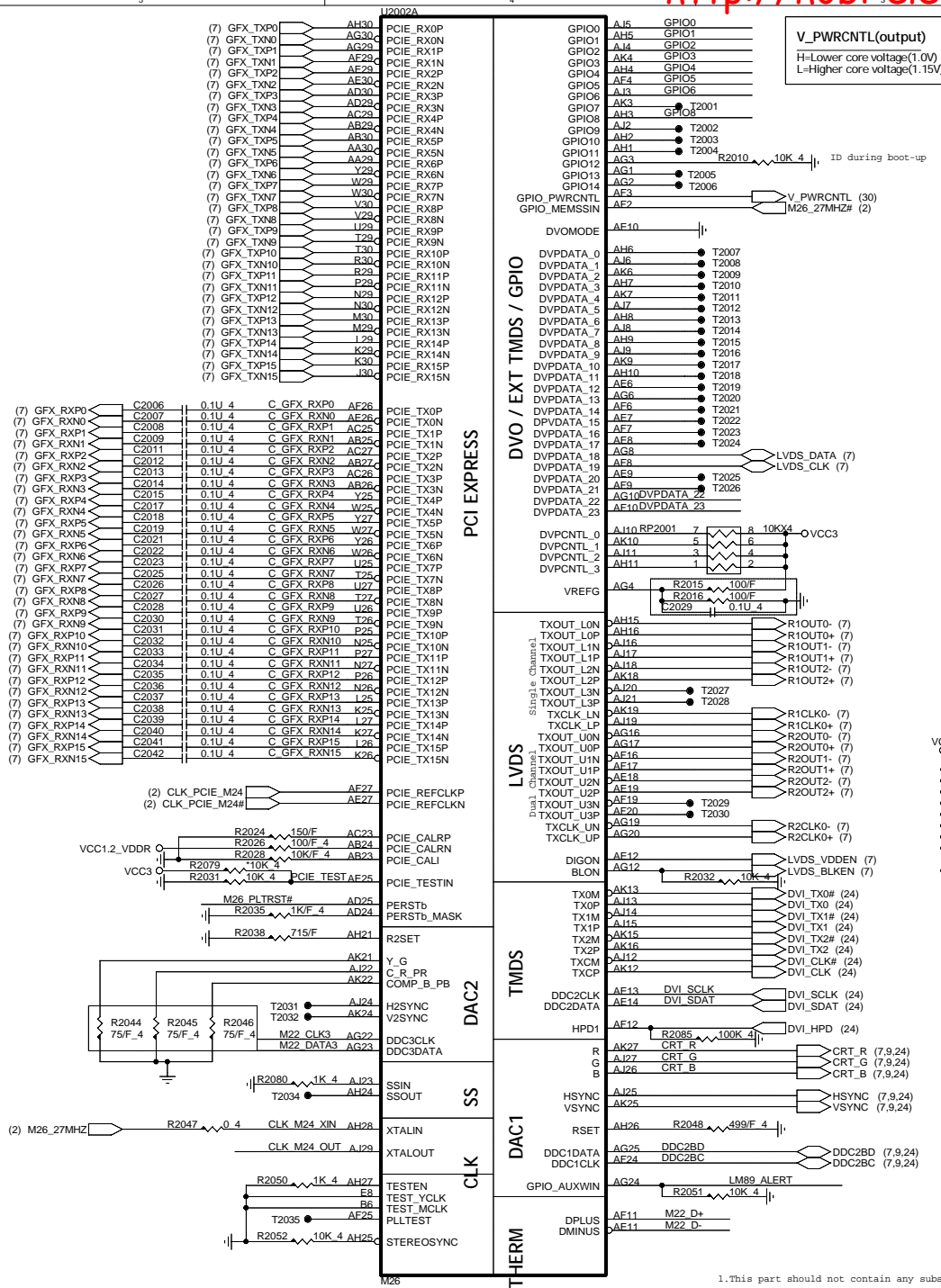

DVPDATA 22-23	DATA23 Vendor	DATA22 Vendor	MEM SIZE
0	0	Hynix	64M
0	1	Hynix	128M
MEM TYPE	+ 1	0	Samsung 64M
		1	Samsung 128M

PCI_TEST	ATI Internal USE 0: Default
GPIO_0	Transmitter Power Savings Enable 0: 50% Tx output swing for mobile mode 1: full Tx output swing
GPIO_1	Transmitter De-emphasis Enable 0: Tx de-emphasis disabled for mobile mode 1: Tx de-emphasis enabled
GPIO_(3,2)	00: PCI Express 1.0 mode 01: Kyrene-compatible mode 10: PCI Express 1.0 mode 11: PCI Express 1.0A mode and short-circuit internal loopback mode (Rx connected directly to Tx of PHY)
GPIO_4	0: NON REVERSED LANES IN LAYOUT 1: REVERSED LANES IN LAYOUT
GPIO_5	DO NOT FORCE COMPLIANCE STATE QUICKLY
GPIO_6	COMMON MODE RANGE 0: Default
GPIO_8	DEBUG SIGNALS NOT BROUGHT OUT
GPIO(9,13;11)	NO USE:0000 (ID[1:4] = GPIO[11,12,13,9]) 0x0x: No ROM, CHG_ID=0 0x1x: No ROM, CHG_ID=1 1011 - Serial M25P10 ROM (ST), chip ID is from ROM 1100 - Serial M25P05 ROM (ST), chip ID is from ROM

QUANTA COMPUTER

Size Document Number Rev
 RJS ATI M26 1A

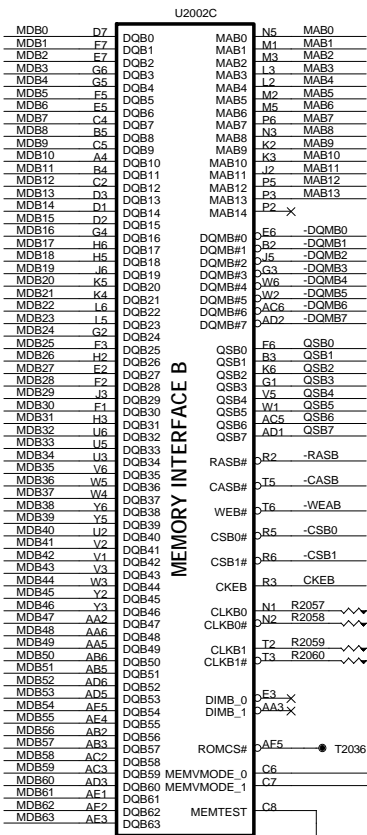

MEMORY INTERFACE B

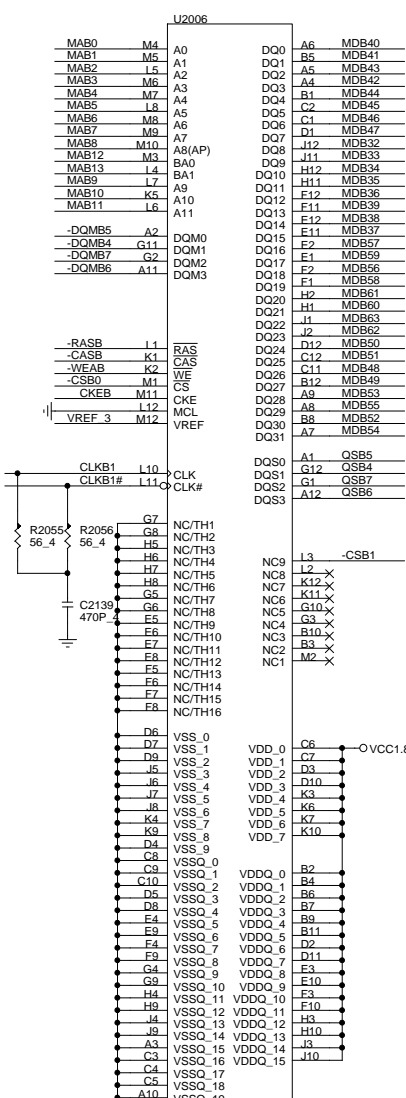
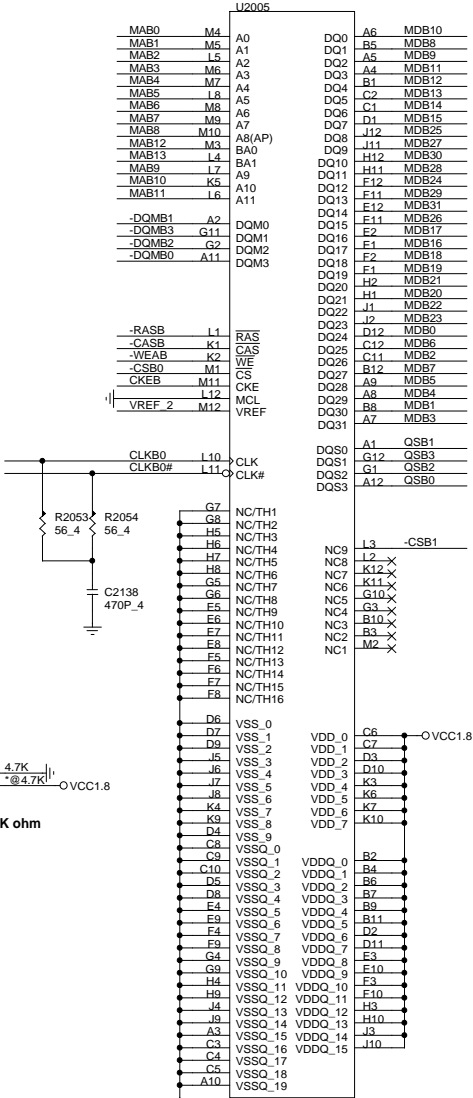

VDDR1	MEMVMODE_0	MEMVMODE_1
1.8V	GND	VCC1.8
2.5V	VCC1.8	GND

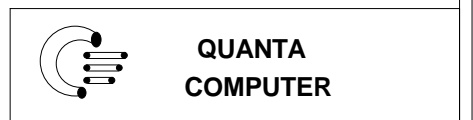
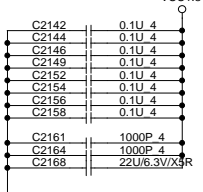
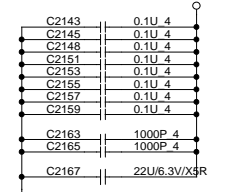
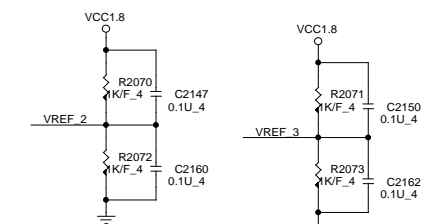

1. This part should not contain any substances which are specified in SS-00259-1
2. Purchase ink, paint, wire rods and molding resins only from the business partners that Sony approves as Green Partners.

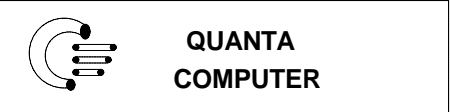
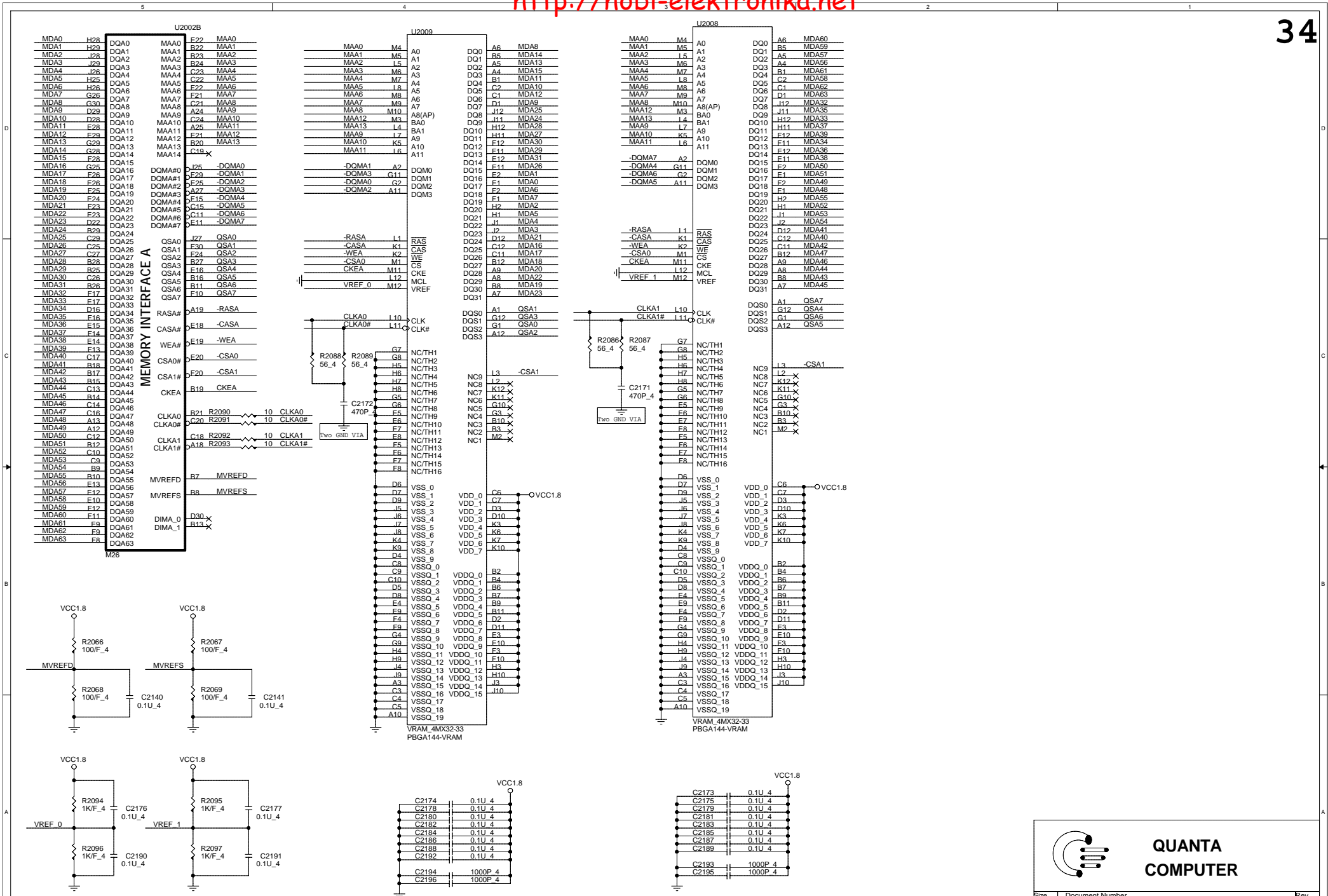

Size	Document Number	Rev
	RJ5 ATI M26	1A
Date:	Friday, April 22, 2005	Sheet 34 of 36

1. This part should not contain any substances which are specified in SS-00259-1
 2. Purchase ink, paint, wire rods and molding resins only from the business partners that Sony approves as G&E Partners.

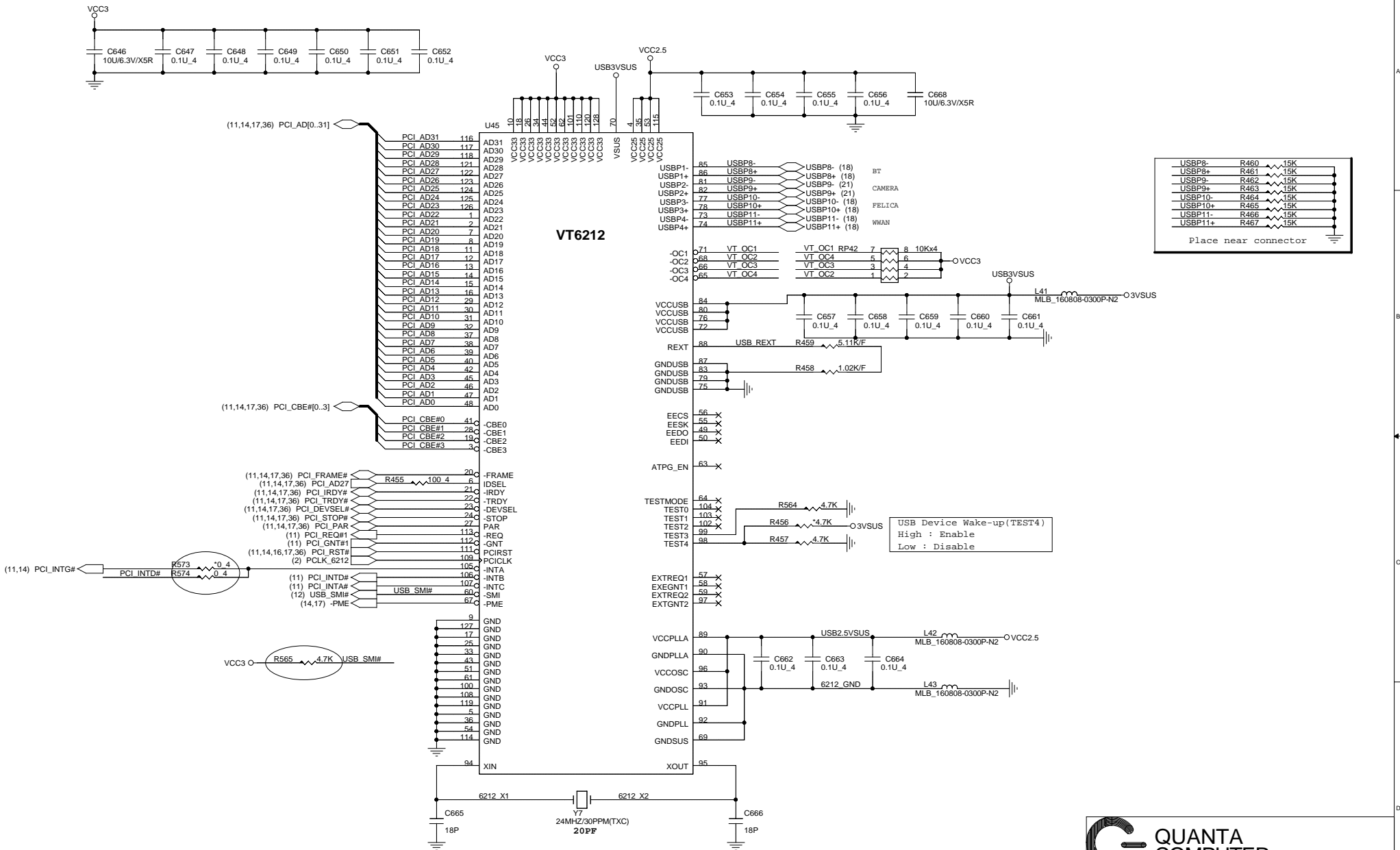

QUANTA COMPUTER

Title: **USB Controller VT6212**

Size: Document Number: **RJ5 Main Board** Rev: 2A

Date: Thursday, May 26, 2005 Sheet: 35 of 36

1. This part should not contain any substances which are specified in SS-00259-1
 2. Purchase ink, paint, wire rods and molding resins only from the business partners that Sony approves as Green Partners.

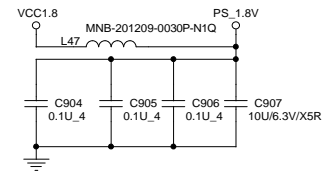
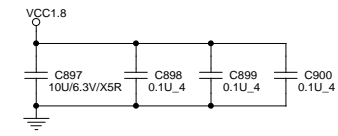
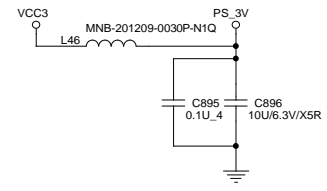
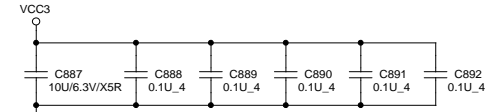
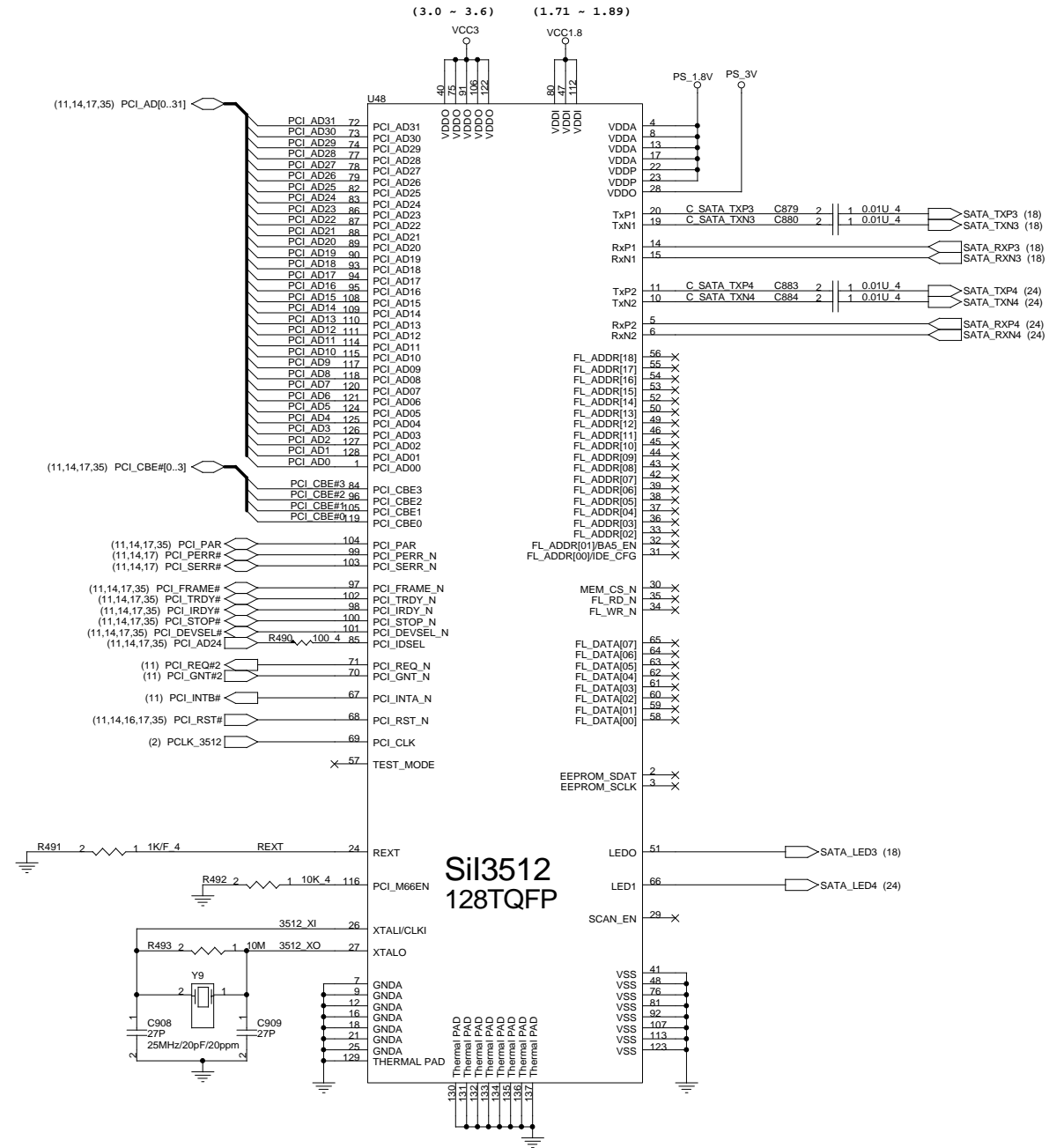

**Si3512
128TQFP**

QUANTA COMPUTER

Title: **PCI-SATA Si3512**

Size	Document Number	Rev
Custom	RJ5 Main Board	1A
Date:	Thursday, May 26, 2005	Sheet 36 of 36

1. This part should not contain any substances which are specified in SS-00259-1
 2. Purchase ink, paint, wire rods and holding resins only from the business partners that Sony approves as Green Partners.