

CD RECEIVER

KDC-W237AY/W237GY
 KDC-W3037AY/W3037GY
 KDC-W311AY/W311GY
 KDC-W3537AY/W3537GY/W4037Y
SERVICE MANUAL

KENWOOD

Kenwood Corporation

© 2006-12 PRINTED IN JAPAN
 B53-0483-00 (N) 229

Panel assy
 KDC-W237AY/W237GY (A64-4058-02)

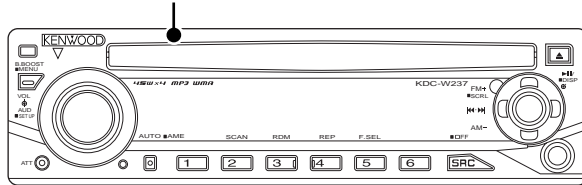

Panel assy
 KDC-W3037AY/W3037GY (A64-4056-12)

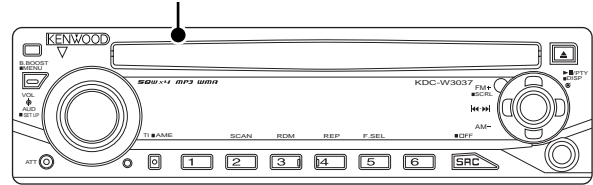

Panel assy
 KDC-W311AY/W311GY (A64-4057-12)

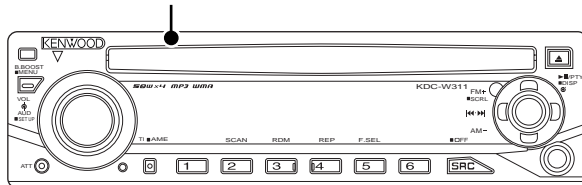

Panel assy
 KDC-W3537AY/W3537GY (A64-4042-12)

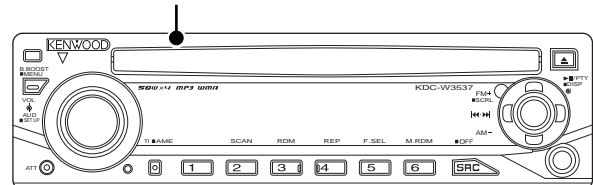

Panel assy
 KDC-W4037Y (A64-4038-12)

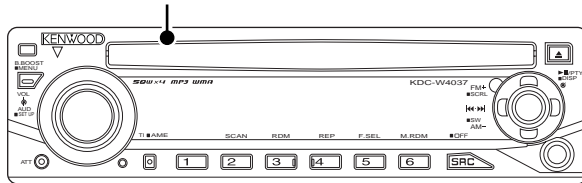

SPARE TDF PANEL

MAIN UNIT NAME	TDF PARTS No.	TDF NAME
KDC-W237AY	Y33-2660-60	TDF-W237A
KDC-W237GY	Y33-2660-61	TDF-W237G
KDC-W3037AY	Y33-2650-63	TDF-W3037A
KDC-W3037GY	Y33-2650-64	TDF-W3037G
KDC-W311AY	Y33-2650-65	TDF-W311A
KDC-W311GY	Y33-2650-66	TDF-W311G
KDC-W3537AY	Y33-2650-61	TDF-W3537A
KDC-W3537GY	Y33-2650-62	TDF-W3537G
KDC-W4037Y	Y33-2650-60	TDF-W4037

Lever
 (D10-4589-04) x2

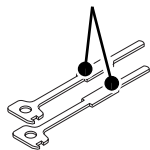

DC cord
 (E30-6427-05)

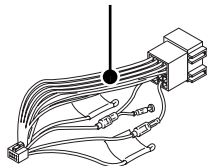

Carrying case
 (W01-1685-05)

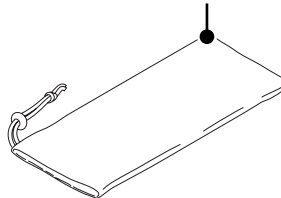

* Remote controller assy (RC-557)
 (A70-2087-05)

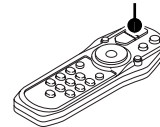

Battery
 (Not supplied)

Antenna adaptor
 (T90-0523-05)



* Escutcheon
 (B07-xxxx-xx)

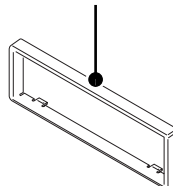

Mounting hardware assy
 (J21-9716-03)

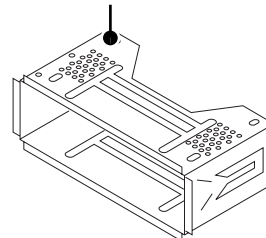

* Depends on the model. Refer to the parts list.



BLOCK DIAGRAM

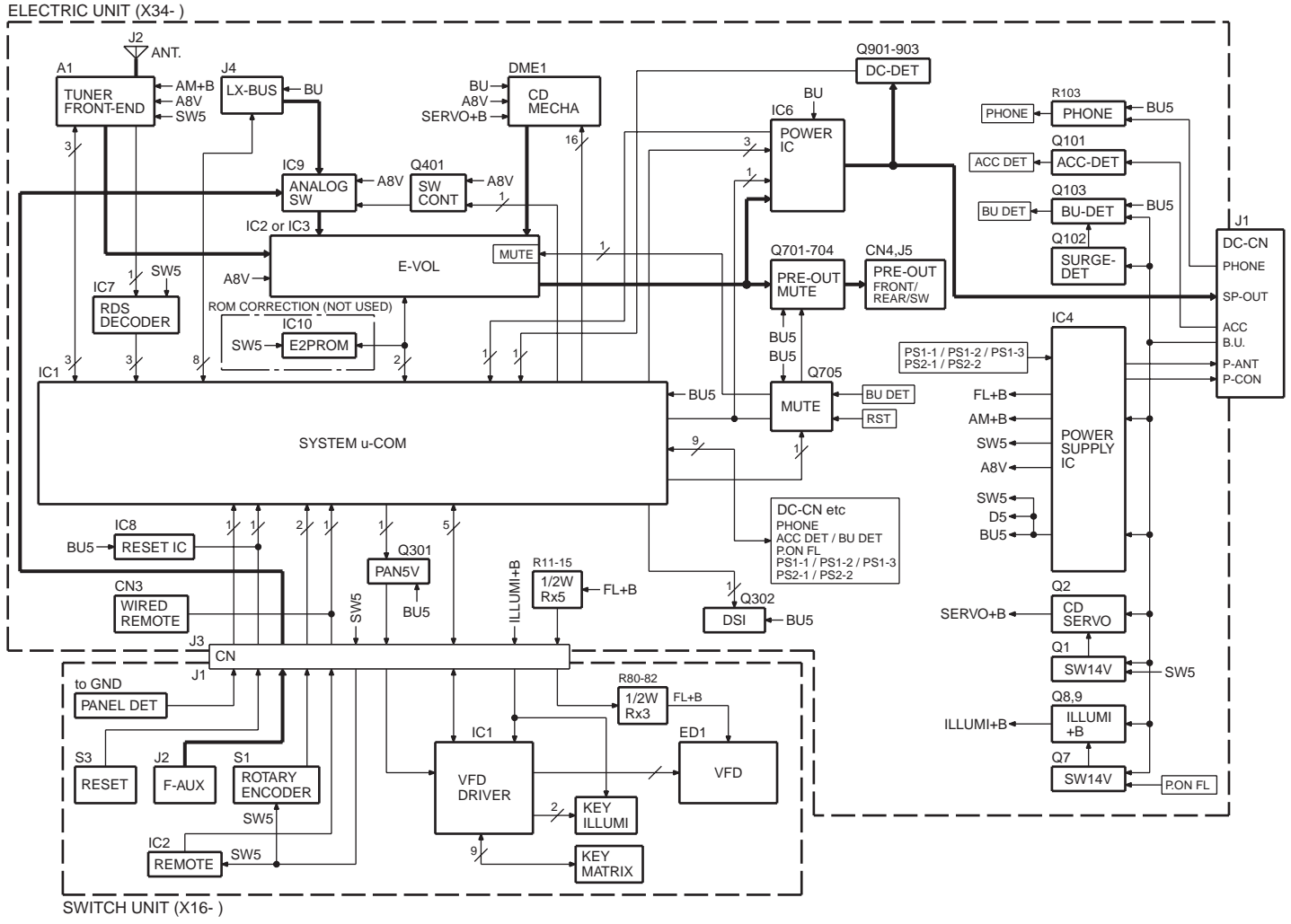

BLOCK DIAGRAM

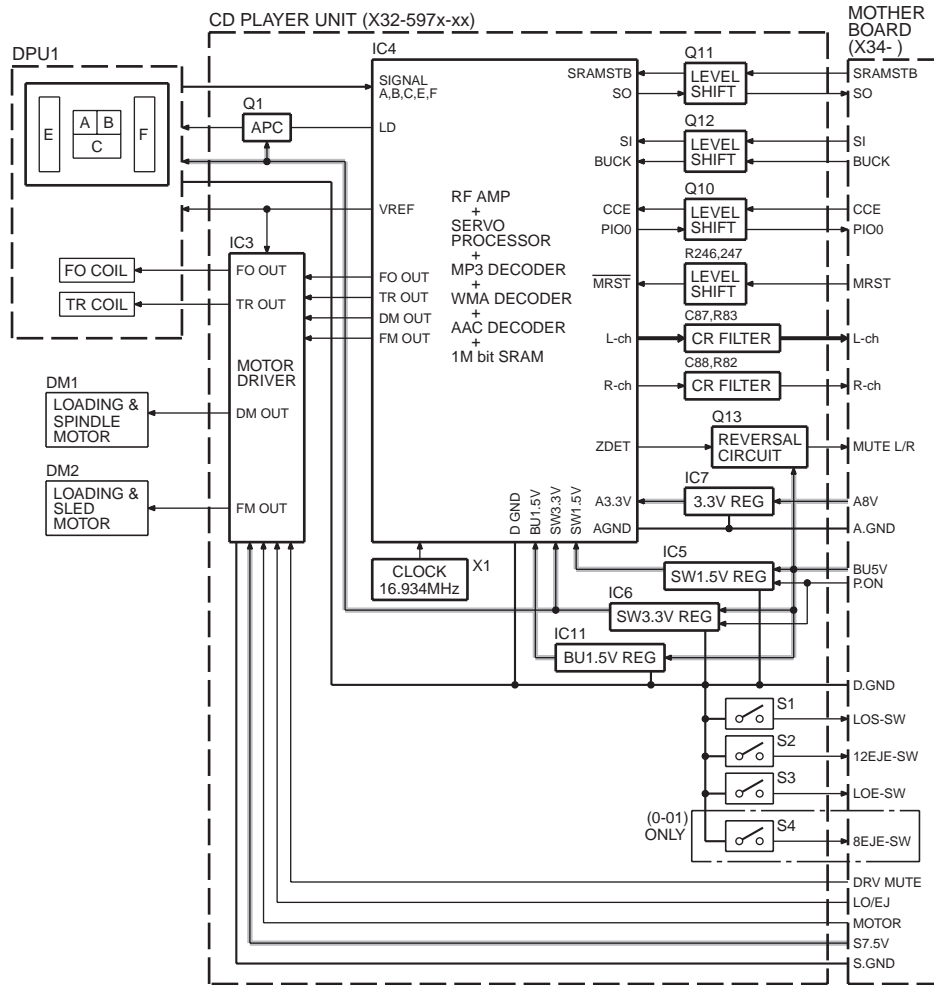

COMPONENTS DESCRIPTION

● ELECTRIC UNIT (X34-467x-xx)

Ref. No.	Application / Function	Operation / Condition / Compatibility
IC1	System μ -COM	Controls FM/AM tuner, the changer, CD mechanism, panel, volume and tone.
IC2,3	E-VOL	Controls the source, volume and tone.
IC4	Power Supply IC	Outputs 5Vx2, 8.1Vx2, 10.2V, P-CON and P-ANT.
IC6	Power IC	Amplifies the front L/R and the rear L/R to 50W or 45W maximum.
IC7	RDS IC	RDS decoder.
IC8	Reset IC	Lo when detection voltage goes below 3.6V.
IC9	Analog SW	Multiplex triple 2-channel analog SW.
Q1	SW14V	ON when the base goes Hi.
Q2	Servo+B AVR	When Q3's base goes Hi, Servo+B AVR outputs 7.5V.
Q3	Control SW for Servo+B	ON when the base goes Hi.
Q7	VFD+B SW	ON when the base goes Hi.
Q8	VFD+B AVR	When Q9's base goes Hi, Servo+B AVR outputs 10.5V.
Q9	Control SW for VFD+B	ON when the base goes Hi.
Q101	ACC DET	ON when the base goes Hi during ACC is applied.
Q102	Serge DET	When the base goes Hi, surge voltage is detected.
Q103	BU DET	ON when the base goes Hi during BU is applied.
Q104,105	Mute Control	ON when the base goes Hi.
Q301	Panel 5V SW	ON when the base goes Lo.
Q302	DSI ILLUMI SW	ON when the base goes Hi.
Q401	IC9 Control SW	Switches to AUX when the base goes Hi, and switches to LX-BUS (CD-CH) when the base goes Lo.
Q402	Quick Charge Voltage SW	Charges voltage quickly when the base goes Hi.
Q701,702	Pre-out Mute SW	When a base of the 4 transistors goes Hi, pre-out is muted.
Q705	Mute Driver for Pre-out	ON when the base goes Lo.
Q901	DC Offset DET	ON when the base goes Hi after Q902's and Q903's outputs are separated.
Q902,903	DC Offset DET SW	ON when the bases go Lo after IC6's SP-OUTs (DC) are separated.

● SWITCH UNIT (X16-386x-xx)

Ref. No.	Application / Function	Operation / Condition / Compatibility
IC1	VFD Driver	
IC3	Remote Control Sensor	
Q1	GREEN LED SW	ON when the base goes Hi.
Q2	RED LED SW	ON when the base goes Hi.

● CD PLAYER UNIT (X32-5970-00)

Ref. No.	Application / Function	Operation / Condition / Compatibility
IC3	4ch BTL Driver	Driver for focusing & tracking coil, driver for sled & spindle motor, and operation for disc loading & ejection.
IC4	Servo DSP with built-in Audio DAC	With built-in MP3/WMA/AAC decoder and 1M-bit-SRAM.
IC5	D1.5V REG.	Power supply for digital 1.5V.

COMPONENTS DESCRIPTION

Ref. No.	Application / Function	Operation / Condition / Compatibility
IC6	D3.3V REG.	Power supply for digital 3.3V.
IC7	A3.3V REG.	Power supply for audio 3.3V.
IC11	BU1.5V REG.	Power supply for back-up 1.5V.
Q1	APC (Auto Power Control)	Drives LD (Laser Diode).
Q10~12	5V~3.3V Level Shift	Converts signal from 5V to 3.3V, or from 3.3V to 5V.
Q13	Inverter	Inverts ZDET signal.
D1	Level Down	Lowers signal level by about 1.2V so that Lo level signal that turns the regulator ON/OFF surely becomes Lo judgment level of the regulator SW.
D2	Laser Diode Protection	Prevents reverse bias which is applied to laser. Laser destruction prevention.
D3,4	Static Electricity Countermeasure	Prevents malfunction by static electricity.

MICROCOMPUTER'S TERMINAL DESCRIPTION

● SYSTEM μ -COM: IC1 on X34- (ELECTRIC UNIT)

Pin No.	Pin Name	I/O	Application	Truth Value Table	Processing Operation Description
1	LX DATA M	I/O	Data to slave unit		Pull-down (GND)
2	LX CLK	I/O	LX-BUS clock		125k~65kHz
3~5	NC	-	Not used		Output Lo fixed
6	REMO	I	Remote control signal input		Detects pulse width
7	NC	-	Not used		Output L fixed
8	BYTE	I	Memory extended bus width setting		Connects to VSS
9	CNVSS	-			Connects to VSS
10	XCIN	-	32.768kHz		
11	XCOU	-	32.768kHz		
12	$\overline{\text{RESET}}$	-			L: Reset
13	XOUT	-	10.0MHz		
14	VSS	-			
15	XIN	-	10.0MHz		
16	VCC1	-			
17	NMI	I			Connects to VSS
18	$\overline{\text{PANEL DET}}$	I	Panel communication detection		H: Panel detached, L: Panel attached
19,20	NC	-	Not used		Output L fixed
21	ROMCOR DET	I	E2PROM writing request		H: Writing
22,23	NC	-	Not used		Output L fixed

MICROCOMPUTER'S TERMINAL DESCRIPTION

Pin No.	Pin Name	I/O	Application	Truth Value Table	Processing Operation Description
24	PON FL	O	Key illumination power supply control		ON: H, OFF: L
25	NC	-	Not used		
26	$\overline{\text{PON PANEL}}$	I/O	Panel 5V control		ON: L, Momentary power down/Panel detached : Hi-Z, 11 minutes after ACC OFF: Hi-Z
27	NC	-	Not used		Output L fixed
28	PWIC BEEP	O	Beep output		
29	AUD SCL	I/O	E-VOL clock output		
30	AUD SDA	I/O	E-VOL data input/output		
31	VFD SYS DATA	O	VFD data output		
32	VFD PAN DATA	I	VFD data input		
33	VFD CLK	O	VFD clock output		125kHz
34	VFD BLK	O	VFD data blanking output		H: Reset cancelled, L: Reset, Momentary power down /Panel detached: L, 11 minutes after ACC OFF: L
35	CD SI	O	CD mechanism serial output		
36	CD SO	I	CD mechanism serial input		
37	CD CLK	O	Serial clock output		1MHz
38	CD LOS SW	I	CD loading detection		
39	PIO0	I	Communication request from mechanism DSP		H: Data request
40	CD SRAMSTB	O	1M-bit SRAM standby		H: SRAM standby
41	EPM	I	Flash EPM input		Connects to VSS
42	CD LOE LIM SW	I	CD detection (Chucking SW)		H: Loading completed, L: No disc
43	PON CD	O	CD mechanism power supply control		H: Power ON
44	CD LOEJ	I/O	CD motor control	①	Refer to the truth value table
45	CD MOTOR	I/O	CD motor control	①	Refer to the truth value table
46	VFD CE	O	VFD control request		
47	CD DRIVEMUTE	O	Motor driver mute output		
48	CD CCE	O	CD mechanism chip enable		
49	CD DISC8 SW	I	8cm disc detection		Pull-up (B.U.)
50	CD MRST	O	CD mechanism μ -com reset		H: Normal, L: Reset
51~53	NC	-	Not used		Output L fixed
54	CD MUTE	I	CD mute request		L: Mute request
55	CD DISC12 SW	I	12cm disc detection		Pull-up (B.U.)
56	ROTARY CCW	I	VOL key input		Detects pulse width
57	ROTARY CW	I	VOL key input		Detects pulse width
58	NC	-	Not used		Output L fixed
59	DSI	I/O	DSI control		OFF: Hi-z, Panel detached: Pulse drives, ON: H
60	RDS DATA	I	RDS decoder data input		
61	RDS QUAL	I	RDS decoder QUAL input		
62	VCC2	-			

MICROCOMPUTER'S TERMINAL DESCRIPTION

Pin No.	Pin Name	I/O	Application	Truth Value Table	Processing Operation Description
63	NC	-	Not used		Output L fixed
64	VSS	-			
65	RDS AFS M	I/O	Noise detection time constant switching	②	Refer to the truth value table
66	TUN IFC OUT	I	Front-end IFC-OUT input		H: Station found, L: No station
67	PON EXT GND	I/O	IC2 external input quick charge control		L: OFF, Hi-Z: Quick charge, When IC2 is in source select: Hi-Z, Mute L: L, Momentary power down/Power OFF: L
68	MUTE	I/O	Mute		L: Mute OFF, Hi-Z: Mute ON
69	ANALOG CON	O	AUX/LX audio switching		AUX: H (Switches after 100ms after first-out mute begins to work), LX/Other source: L
70	LX RST	O	Forced reset to slave unit		H: Reset, L: Normal
71	LX CON	O	Start-up request to slave unit		H: Slave unit ON, L: Slave unit OFF
72	LX MUTE	I	Mute request from slave unit		H: Mute ON, L: Mute OFF
73	LX REQ M	O	Communication request to slave unit		
74	RDS CLK	I	RDS decoder clock input		
75	LX REQ S	I	Communication request from slave unit		Pull-down (GND)
76	PWIC SVR	O	SVR discharging circuit		During 500ms after momentary power down: H, Since then: L
77	PWIC STBY	O	Power IC standby control		Power ON: H, Power OFF: L
78	PWIC MUTE	O	Power IC mute		STANDBY source/Momentary power down: L, TEL mute: L
79	$\overline{\text{ACC DET}}$	I	ACC power supply detection		ACC found: L, No ACC: H
80	$\overline{\text{BU DET}}$	I	Detection of momentary power down		BU found: L, No BU/Momentary power down: H (Operates after less than 4ms after momentary power down is detected)
81,82	NC	O	Not used		Output L fixed
83	RDS NOISE	I	FM noise detection		
84	TUN SMETER	I	S-meter input		
85	TYPE1	I	Destination switching	③	Refer to the truth value table
86	TYPE2	I	Destination switching	③	Refer to the truth value table
87	PWIC DC DET	I	DC offset detection		If DC offset is found 20 times in 100ms with condition of over 1.0V, it will be judged as DC offset detected.
88	LINE MUTE	I	Line mute selection		TEL mute: Below 1V, NAVI mue: Over 2.5V
89	OFFSET DET	I	Power IC offset detection		
90	PS2 2	O	Power supply IC control	④	Refer to the truth value table
91	PS2 1	O	Power supply IC control	④	Refer to the truth value table
92	PS1 1	O	Power supply IC control	④	Refer to the truth value table
93	PS1 2	O	Power supply IC control	④	Refer to the truth value table
94	PS1 3	O	Power supply IC control	④	Refer to the truth value table
95	PON	-	Not used		POWER ON: H, POWER OFF: L

MICROCOMPUTER'S TERMINAL DESCRIPTION

Pin No.	Pin Name	I/O	Application	Truth Value Table	Processing Operation Description
96	AVSS	-			
97	REF CON	O	VREF control		Connects to VREF
98	VREF	-			
99	AVCC	-			
100	LX DATA S	I	Data from slave unit		Pull-down (GND)

• Truth value table

① CD motor control

	CD motor	CD loading/eject
Stop	L	L
Load	H	L
Eject	H	H
Brake	H	Hi-z

② AFS control

	RDS AFS M	Condition
AFS MID	L	Except AF search, seeking or tuner source
AFS HIGH	Hi-Z	Normal reception

③ Destination switching

TYPE 2 (Pin 86)	TYPE 1 (Pin 85)	Model
3.6V	0V	KDC-W3037AY/W3037GY/ W311AY/W311GY/W4037Y
3.6V	1.2V	KDC-W3537AY/W3537GY
3.6V	2.4V	KDC-W237AY/W237GY

④ Power supply IC (IC4) control

SEL1 (Pin 10)

PS1-2	PS1-3	PS2-1	ILLUMI	P-CON	P-ANT
L	L	L	OFF	OFF	OFF
L	L	H	ON	OFF	OFF
H	L	H	ON	ON	OFF
H	H	H	ON	ON	ON

SEL2 (Pin 11)

PS1-1	PS2-2	AUDIO/SW5	AM
L	L	OFF	OFF
H	L	ON	OFF
H	H	ON	ON

TEST MODE

■ Example

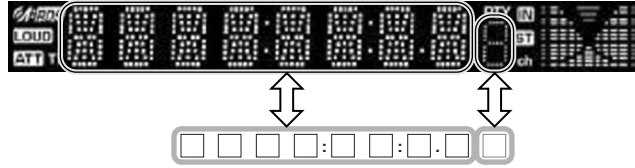

Key	Description of display	Description
5	Disc EJECT times display	Disc EJECT times display. MAX 65535 (times)
■5		While disc EJECT times is displayed, press and hold for 2 seconds or longer to clear disc EJECT times.

A symbol "■" in the key column indicates that the key should be pressed and held for 1 second or longer.

■ How to enter the test mode

Procedure	Note
Press and hold the [1] key and [3] key and reset.	While "---" is displayed, power can be turned ON for only 30 minutes. (KDC-W3537AY/W3537GY/W4037Y only)

All lamps blink when it is detected that the sub-clock resonator is disconnected.

Do not display "CODE_OFF", "CODE_ON" or "CODE_NG" when Power is ON.

When having started up in the test mode, change the LINE MUTE inhibition time from 10 seconds to 1 second.

When operating in the test mode, even if a DC offset error occurs, detection information is not written in the E2PROM.

When operating in the test mode, CD mechanism error log information clear mode, and DC offset error detection information clear mode, do not perform DEMO mode operations.

Also, do not display DEMO ON/OFF option items in the MENU in STANDBY source in the above modes.

Forced disc ejection is prohibited in the test mode.

■ How to clear the test mode

Procedure	Note
Reset, momentary power down, ACC OFF, Power OFF, Panel detached.	Clearing the test mode

■ Test mode default condition

Description	Default values
Source	STANDBY
Display	Display lights are all turned on.
Volume	-10dB ("30" is displayed.)
Bass Boost	OFF
CRSC	OFF regardless of having/not having the switching function.
AUX	ON
System Q	NATURAL (FLAT)
Beep	Sound on with a key pressed regardless of any settings.
Preout	Sub Woofer

TEST MODE

■ Special displays when all lights are on in STANDBY source

Key	Description of display	Description
Common	All lights ON. <input type="checkbox"/> <input type="checkbox"/> <input type="checkbox"/> <input type="checkbox"/> <input type="checkbox"/> <input type="checkbox"/> <input type="checkbox"/> <input type="checkbox"/> <input type="checkbox"/> <input type="checkbox"/>	All lights ON.
1	Destination terminal condition indication <input type="checkbox"/> T <input type="checkbox"/> Y <input type="checkbox"/> P <input type="checkbox"/> E : <input type="checkbox"/> 1 <input type="checkbox"/> 1 <input type="checkbox"/> <input type="checkbox"/> <input type="checkbox"/> <input type="checkbox"/> <input type="checkbox"/>	"TYPE" indicates system μ -com (IC1) destination, and shows real-time condition of the destination terminal.
	Development ID condition indication <input type="checkbox"/> 6 <input type="checkbox"/> 1 <input type="checkbox"/> 1 <input type="checkbox"/> A <input type="checkbox"/> 2 <input type="checkbox"/> - <input type="checkbox"/> 3 <input type="checkbox"/> . <input type="checkbox"/> 0 <input type="checkbox"/> 0	Development ID – Version (system μ -com: IC1)
2	Serial No. display <input type="checkbox"/> 0 <input type="checkbox"/> 0 <input type="checkbox"/> 0 <input type="checkbox"/> 0 <input type="checkbox"/> 0 <input type="checkbox"/> 0 <input type="checkbox"/> 0 <input type="checkbox"/> <input type="checkbox"/>	Serial No. is displayed (8 digits)
3	Power ON time display <input type="checkbox"/> P <input type="checkbox"/> O <input type="checkbox"/> N <input type="checkbox"/> <input type="checkbox"/> 0 <input type="checkbox"/> H <input type="checkbox"/> X <input type="checkbox"/> X <input type="checkbox"/> <input type="checkbox"/>	00~50 is displayed for "XX". When less than 1 hour, displayed by increments of 10 minutes.
	<input type="checkbox"/> P <input type="checkbox"/> O <input type="checkbox"/> N <input type="checkbox"/> X <input type="checkbox"/> X <input type="checkbox"/> X <input type="checkbox"/> X <input type="checkbox"/> X <input type="checkbox"/> <input type="checkbox"/>	00001~10922 is displayed for "XXXXX". MAX 10922 (hours)
■3		When Power ON time is displayed, press and hold for 2 seconds or longer to clear Power ON time.
4	Disc operation time display <input type="checkbox"/> C <input type="checkbox"/> D <input type="checkbox"/> T <input type="checkbox"/> <input type="checkbox"/> 0 <input type="checkbox"/> H <input type="checkbox"/> X <input type="checkbox"/> X <input type="checkbox"/> <input type="checkbox"/>	00~50 is displayed for "XX". When less than 1 hour, displayed by increments of 10 minutes.
	<input type="checkbox"/> C <input type="checkbox"/> D <input type="checkbox"/> T <input type="checkbox"/> X <input type="checkbox"/> X <input type="checkbox"/> X <input type="checkbox"/> X <input type="checkbox"/> X <input type="checkbox"/> <input type="checkbox"/>	00001~10922 is displayed for "XXXXX". MAX 10922 (hours)
■4		While the disc operation time is displayed, press and hold for 2 seconds or longer to clear the disc operation time. (Cleared only for displayed media.)
5	Disc EJECT times display <input type="checkbox"/> E <input type="checkbox"/> J <input type="checkbox"/> C <input type="checkbox"/> X <input type="checkbox"/> X <input type="checkbox"/> X <input type="checkbox"/> X <input type="checkbox"/> X <input type="checkbox"/> <input type="checkbox"/>	Disc EJECT times display. MAX 65535 (times)
	■5	
6	Panel open/close times display <input type="checkbox"/> P <input type="checkbox"/> C <input type="checkbox"/> <input type="checkbox"/> X <input type="checkbox"/> X <input type="checkbox"/> X <input type="checkbox"/> X <input type="checkbox"/> X <input type="checkbox"/> <input type="checkbox"/>	PANEL open/close times display. MAX 65535 (times)
	■6	
FM	ROM correction version display <input type="checkbox"/> R <input type="checkbox"/> O <input type="checkbox"/> 1 <input type="checkbox"/> 2 <input type="checkbox"/> 3 <input type="checkbox"/> <input type="checkbox"/> <input type="checkbox"/> <input type="checkbox"/> <input type="checkbox"/> <input type="checkbox"/>	The number is the ROM correction version number.
	<input type="checkbox"/> E <input type="checkbox"/> R <input type="checkbox"/> R <input type="checkbox"/> <input type="checkbox"/> <input type="checkbox"/> <input type="checkbox"/> <input type="checkbox"/> <input type="checkbox"/> <input type="checkbox"/> <input type="checkbox"/>	When E2PROM is not installed.
	<input type="checkbox"/> R <input type="checkbox"/> - <input type="checkbox"/> - <input type="checkbox"/> - <input type="checkbox"/> - <input type="checkbox"/> <input type="checkbox"/> <input type="checkbox"/> <input type="checkbox"/> <input type="checkbox"/> <input type="checkbox"/>	When not written in yet.
	<input type="checkbox"/> R <input type="checkbox"/> * <input type="checkbox"/> * <input type="checkbox"/> * <input type="checkbox"/> * <input type="checkbox"/> <input type="checkbox"/> <input type="checkbox"/> <input type="checkbox"/> <input type="checkbox"/> <input type="checkbox"/>	When data not matched. (due to the difference in versions)
■AM	ROM data transfer <input type="checkbox"/> <input type="checkbox"/> <input type="checkbox"/> <input type="checkbox"/> <input type="checkbox"/> <input type="checkbox"/> <input type="checkbox"/> <input type="checkbox"/> <input type="checkbox"/> <input type="checkbox"/>	
▶▶	Audio data initialization <input type="checkbox"/> A <input type="checkbox"/> U <input type="checkbox"/> D <input type="checkbox"/> <input type="checkbox"/> I <input type="checkbox"/> N <input type="checkbox"/> I <input type="checkbox"/> T <input type="checkbox"/> <input type="checkbox"/>	AUDIO setting value is re-set to the test mode default value.
◀◀	Forced Power OFF information display <input type="checkbox"/> P <input type="checkbox"/> O <input type="checkbox"/> F <input type="checkbox"/> F <input type="checkbox"/> <input type="checkbox"/> - <input type="checkbox"/> - <input type="checkbox"/> - <input type="checkbox"/> <input type="checkbox"/>	No forced power OFF
	<input type="checkbox"/> P <input type="checkbox"/> O <input type="checkbox"/> F <input type="checkbox"/> F <input type="checkbox"/> <input type="checkbox"/> S <input type="checkbox"/> E <input type="checkbox"/> C <input type="checkbox"/> <input type="checkbox"/>	Forced power OFF because of missing Security Code. (Code security supporting model)
	<input type="checkbox"/> P <input type="checkbox"/> O <input type="checkbox"/> F <input type="checkbox"/> F <input type="checkbox"/> <input type="checkbox"/> P <input type="checkbox"/> N <input type="checkbox"/> L <input type="checkbox"/> <input type="checkbox"/>	Forced power OFF by communication error between system μ -com and panel.
■◀◀		While the forced power OFF data is displayed, press and hold for 2 seconds to clear the data.
▶▶	CD information display mode ON/OFF <input type="checkbox"/> <input type="checkbox"/> <input type="checkbox"/> <input type="checkbox"/> <input type="checkbox"/> <input type="checkbox"/> <input type="checkbox"/> <input type="checkbox"/> <input type="checkbox"/> <input type="checkbox"/>	For the display contents, refer to "CD information display mode" in the next section.
	■▶▶	

TEST MODE

• CD information display mode

Key	Description of display	Description	
FM (forward rotation) AM (reverse rotation)	CD mechanism error log display	M C E R R 1 : X X <input type="checkbox"/>	Mechanism error log 1 (Latest) XX: Error number. “- -” is displayed in case there is no error.
		M C E R R 2 : X X <input type="checkbox"/>	Mechanism error log 2 (Latest) XX: Error number. “- -” is displayed in case there is no error.
		M C E R R 3 : X X <input type="checkbox"/>	Mechanism error log 3 (Latest) XX: Error number. “- -” is displayed in case there is no error.
◀◀ / ▶▶	CD Load error information display	L D E R R 1 : X X <input type="checkbox"/>	Load error switch 1 XX: Number of errors. “- -” is displayed in case there is no error.
		L D E R R 2 : X X <input type="checkbox"/>	Load error switch 2 XX: Number of errors. “- -” is displayed in case there is no error.
◀◀ / ▶▶	CD Ejection error information display	E J E R R 1 : X X <input type="checkbox"/>	Ejection error switch 1 XX: Number of errors. “- -” is displayed in case there is no error.
		E J E R R 2 : X X <input type="checkbox"/>	Ejection error switch 2 XX: Number of errors. “- -” is displayed in case there is no error.
		E J E R R 3 : X X <input type="checkbox"/>	Ejection error switch 3 XX: Number of errors. “- -” is displayed in case there is no error.
		E J E R R 4 : X X <input type="checkbox"/>	Ejection error switch 4 XX: Number of errors. “- -” is displayed in case there is no error.
◀◀ / ▶▶	CD time code error count data display (Missing counts)	C N T <input type="checkbox"/> L O S E <input type="checkbox"/>	CD time code error count data (Missing counts) mode display.
		C D D A <input type="checkbox"/> : X X <input type="checkbox"/>	Number of CD-DA count errors XX: Number of errors. “- -” is displayed in case there is no error.
		C D R O M <input type="checkbox"/> : X X <input type="checkbox"/>	CD-ROM (Compressed file) number of count errors XX: Number of errors. “- -” is displayed in case there is no error.
◀◀ / ▶▶	CD time code error count data display (count not updated)	C N T <input type="checkbox"/> S T A Y <input type="checkbox"/>	CD time code error count data (count not updated) mode display.
		C D D A <input type="checkbox"/> : X X <input type="checkbox"/>	Number of CD-DA count errors XX: Number of errors. “- -” is displayed in case there is no error.
		C D R O M <input type="checkbox"/> : X X <input type="checkbox"/>	CD-ROM (Compressed file) Number of count errors XX: Number of errors. “- -” is displayed in case there is no error.

TEST MODE

■ Test mode specifications in TUNER source

Error is found in front-end (A1), etc. if indications below is displayed while in tuner source.

Status	Display	Description
Front-end (A1) E2PROM data error	T N E 2 P □ N G □	Front-end (A1) E2PROM is still the default (unspecified) value.
Front-end (A1) communication error	T N C O N □ N G □	Communication with front-end (A1) is not possible.

• TUNER preset operation

Key	Description of display	Description
4	Preset function F M 1 □ 9 8 . 3 A 4	Change to 98.3MHz with the preset key [4].

• K3I forced switching

Every time when [6] key is pressed in tuner FM source, switched in the following order: AUTO → Forced WIDE → Forced MIDDLE → Forced NARROW → AUTO. Default status is AUTO, and displayed as shown below.

Key	Description of display	Description
6	K3I Forced switching F M 1 □ 9 8 . 1 A □	AUTO
	F M 1 □ 9 8 . 1 W □	Forced WIDE
	F M 1 □ 9 8 . 1 M □	Forced MIDDLE
	F M 1 □ 9 8 . 1 N □	Forced NARROW

• RDS auto measurement

Add the process to replace the visual inspection of PS display previously done in the production line.

Status	Display	Description
PS data reception	R D S □ T E S T □	If displayed as shown at the left, force to OFF. P-CON is recovered by Power OFF/ON.

• FST adjustment mode

Perform FST soft-mute adjustment.

Key	Note
■▶	Enter the FST adjustment mode. (Press for 1 second or longer.)

Operations in the FST adjustment mode are as follows:

Key	Description of display	Description
FM (UP) AM (DOWN)	Soft-mute adjustment S M D - F □ □ □ □	18dBμ (0) ↔ 36dBμ (F)
■▶	Adjustment value memory E P □ W R I T E □	Displays the data that has been written in the E2PROM when pressing the key for 2 seconds or longer.
▶	Mode clear F M 1 □ 9 8 . 3 A 4	Clear the FST adjustment mode. (Returns to normal display and the test mode is retained.)

After completing the FST adjustment, if You wish to clear the test mode, You can do this using the reset button.

TEST MODE

■ Test mode specifications in CD source

Display mode default: P-Time

• Procedure in CD-DA media (KTD-02A)

Key	Description of display		Description
▶▶	Track up procedure		Every time pressed, jumps to the track shown below. No.9 → No.15 → No.10 → No.11 → No.12 → No.13 → No.22 → No.14 → No.9 (recursive) But in case the disc has 8 tracks or less, playback starts with track No.1. (For both CD-DA and compressed file discs)
◀◀	Track down procedure		Goes down by 1 track from the currently played track.
1	Jump procedure		Jump to No. 28 (Scratch 0.7mm for MUSIC line vibration testing)
2	Jump procedure		Jump to No. 14 (Blurring surface disc TCD-731RA Tr14)
3	Information display Mechanism model name Mechanism version	6 E 0 0 : □ □ □ □ □	Display of Mechanism model name and Mechanism version. (When key is pressed while the display in the left is being shown, returns to normal display.)
6	Jump procedure		Jump to No. 15. Set the volume value to "25". (For 20Hz 0dB DC protection false-operation FCT checking)

Used media: For CD, KTD-02A

■ Audio-related test mode

Procedure	Note
Press the [AUD] key (main unit) Press the [AUD] and [*] keys (Remote control)	Enter audio adjustment mode (the initial item should be Fader, and then, Balance → Bass Level → Middle Level → Treble Level → (SW Level →) System Q → V-Offset → (LPF Sub Woofer.). () means KDC-W4037Y only.

About audio adjustment items (include both Audio Function Mode and Audio Setup Mode)

Procedure	Item	Procedure	Description
For item forwarding procedure, press [AUD] key and [FM] key	Fader	[VOL] knob and [◀◀ / ▶▶] key	Adjust to 3 steps of R15 ↔ 0 ↔ F15. (Default value: 0)
	Balance	[VOL] knob and [◀◀ / ▶▶] key	Adjust to 3 steps of L15 ↔ 0 ↔ R15. (Default value: 0)
	Bass Level	[VOL] knob and [◀◀ / ▶▶] key	Adjust to 3 steps of -8 ↔ 0 ↔ +8. (Default value 0)
	Middle Level	[VOL] knob and [◀◀ / ▶▶] key	Adjust to 3 steps of -8 ↔ 0 ↔ +8. (Default value 0)
	Treble Level	[VOL] knob and [◀◀ / ▶▶] key	Adjust to 3 steps of -8 ↔ 0 ↔ +8. (Default value 0)
	LPF Sub woofer	[VOL] knob and [◀◀ / ▶▶] key	Adjust to 2 steps of 80Hz ↔ Through. (Default value: Through) (Only in models with Sub Woofer output)
	Volume Offset	[VOL] knob and [◀◀ / ▶▶] key	Adjust to 3 steps of -8 ↔ 0 ↔ +8. (Default value 0)

Procedure	Note
Press the [B.BOOST] key for 1 second or longer	Switch Bass Boost (Note: Front key functions as MENU.)

TEST MODE

■ MENU-related test mode

Procedure	Note
Press the [B.BOOST] key (main unit) Press the [DNPP/SBF] and [DIRECT] keys (Remote control)	Continuous forwarding by remote control is prohibited

■ Backup current measurement

Procedure	Note
While ACC OFF (Back Up ON), Reset	MUTE terminal is OFF after 2 seconds, not after 15 seconds. (During this time, the CD mechanism does not function.)

■ PREOUT switching (KDC-W4037Y only)

Procedure	Note
In the STANDBY source, press and hold [TI] key for 1 second or longer	Switches PREOUT

■ Key illumination switching

Procedure	Note
In STANDBY source press [AUTO] or [TI] key	Switches the key illumination GREEN / RED.

■ Fluorescent indicator tube (ED1) short check

Procedure	Note
In the STANDBY source, press [ATT] key	All lights are off → Turns on odd and even terminals alternatively every 125ms (terminals that have a maximum number of grids) → Turns on only the odd terminals → Turn on only the even terminals →

■ Clearing CD mechanism information / Service information / DC offset error information (Clearing E2PROM data)

Status	Display	Description
While pressing and holding [B.BOOST] key and [ATT] key, reset-start.	[C] [D] [] [O] [] [] [] [] []	At normal termination
	[C] [D] [] [X] [] [] [] [] []	At abnormal termination

While “- - - -” is displayed, power can be ON for 30 minutes. This mode is cancelled by resetting. (The last screen will not be retained.)

Data to be cleared is shown below.

CD mechanism information	I2C communication status display
	CD mechanism error log display
	Displays CD loading error data
	Displays CD EJECT error data
	Displays CD time code count error data (missing count)
	Displays CD time code count error data (count not updated)
Service Information	Power ON time display
	CD operation time display
	CD EJECT times display
	PANEL open/close times display
	Forced Power OFF information display
DC offset error information	DC offset error 1 display (Provides information on whether there is an improper connection or another error)
	DC offset error 2 display (Provides information on the number of capacitor leaks)

TEST MODE

■ Clearing DC offset error detection data (E2PROM data clearing)

Procedure	Note
While pressing and holding [3] key and [6] key, reset-start.	Entering DC offset error display mode.

Procedure	Display	Description
Press and hold the [3] and [6] keys, and reset-start	D C □ □ E R R □ □	When DC offset error is detected (when either one of capacitors is leaking, or an improper connection or another error is detected)
	D C □ □ O K □ □ □	When DC offset error is not detected (when none of capacitors leak, no improper connection or other error is detected)
1	D C 1 □ E R R □ □	When improper connection or other DC offset errors are detected.
	D C 1 □ O K □ □ □	When improper connection or other DC offset errors are not detected.
■1	D C 1 □ O K □ □ □	When detecting improper connection or other DC offset errors, clears detection data. (Clear E2PROM)
2	D C 2 □ 4 □ □ □ □	When detecting capacitor leak, provides information on the number of capacitor leaks. (0~4)
■2	D C 2 □ 0 □ □ □ □	When detecting capacitor leak, clears the number of capacitor leaks. (Clear E2PROM)

This mode is cancelled by resetting. (The last screen will not be retained.)

■ Security (KDC-W3537AY/W3537GY/W4037GY only)

• Forced Power ON mode

Procedure	Note
While pressing and holding [B.BOOST] key and [4] key, reset-start.	While "----" is displayed, power can be turned ON for only 30 minutes. After 30 minutes, can only be recovered by resetting.

• How to register the security code on the "Car Audio Passport" after replacement of the FRONT-END (A1) with E2PROM

Procedure	Description
While pressing and holding [1] key and [3] key, reset-start	Enters the test mode
Press the [B.BOOST] key	Enters the MENU mode.
Press and hold [▶▶] key for 1 second or longer	Enters the security registration mode.
[FM] / [AM] / [◀◀] / [▶▶] key	Inputs the code. FM: Number up / AM: Number down / ◀◀ ▶▶ Cursor to the left / ▶▶ ▶▶ Cursor to the right
Press and hold [▶▶] key for 3 seconds or longer	"RE-ENTER" is displayed.
[FM] / [AM] / [◀◀] / [▶▶] key	Inputs the code again. FM: Number up / AM: Number down / ◀◀ ▶▶ Cursor to the left / ▶▶ ▶▶ Cursor to the right
Press and hold [▶▶] key for 3 seconds or longer	"APPROVED" is displayed.
Reset, momentary power down, ACC OFF, Power OFF, panel removed	Cancels the test mode.

Note: The security code in this model cannot be all-clear.

TEST MODE

■ ROM data transfer

When replacing front-end (A1), this function is used to transfer E2PROM data (ROM correction, security and other data) to front-end (A1) to E2PROM of to mother unit (X34-), used for saving data, and, after completing replacement of front-end (A1), to recover data from the E2PROM of the mother unit (X34-), and for saving data to the new front-end (A1). Refer to "ROM data transfer processes" on the next page for details on front-end (A1) replacement procedures and on the data to be transferred.

Procedure	Display	Description
While pressing and holding [1] key and [3] keys, reset-start	<input type="checkbox"/> <input type="checkbox"/> <input type="checkbox"/> <input type="checkbox"/> : <input type="checkbox"/> <input type="checkbox"/> <input type="checkbox"/> <input type="checkbox"/> <input type="checkbox"/> <input type="checkbox"/>	All lights ON.
Press [B.BOOST] key (MENU)	R O M <input type="checkbox"/> R E A D <input type="checkbox"/>	MENU mode
Press [◀◀] key or [▶▶] key	R O M <input type="checkbox"/> R E A D <input type="checkbox"/>	Front-end (A1) → Mother unit (X34-). Data transfer processing.
	R O M <input type="checkbox"/> W R T <input type="checkbox"/>	Mother unit (X34-) → Front-end (A1). Data transfer processing.
(In the above ROM READ status), ■[▶▶] key for 2 seconds or longer	R E A D <input type="checkbox"/> <input type="checkbox"/> <input type="checkbox"/> <input type="checkbox"/>	Front-end (A1) → Mother unit (X34-). ROM data is being transferred.
	R E A D <input type="checkbox"/> O K <input type="checkbox"/>	Front-end (A1) → Mother unit (X34-). ROM correction transfer, security and other data is OK.
	R E A D <input type="checkbox"/> O K 2 <input type="checkbox"/>	Front-end (A1) → Mother unit (X34-). Transfer of security and other data is OK.
	R E A D <input type="checkbox"/> N G <input type="checkbox"/>	Front-end (A1) → Mother unit (X34-). ROM data transfer is NG.
(In the above ROM WRT status), ■[▶▶] key for 2 seconds or longer	W R T <input type="checkbox"/> <input type="checkbox"/> <input type="checkbox"/> <input type="checkbox"/>	Mother unit (X34-) → Front -end (A1). ROM data is being transferred.
	W R T <input type="checkbox"/> <input type="checkbox"/> O K <input type="checkbox"/>	Mother unit (X34-) → Front-end (A1). ROM correction, security and other data transfer is OK.
	W R T <input type="checkbox"/> <input type="checkbox"/> O K 1 <input type="checkbox"/>	Mother unit (X34-) → Front-end (A1). ROM correction data transfer is OK.
	W R T <input type="checkbox"/> <input type="checkbox"/> O K 2 <input type="checkbox"/>	Mother unit (X34-) → Front-end (A1). Transfer of security and other data is OK.
	W R T <input type="checkbox"/> <input type="checkbox"/> N G <input type="checkbox"/>	Mother unit (X34-) → Front-end (A1). ROM data transfer is NG
(In every status of ROM data [▶▶] transfer processing)	<input type="checkbox"/> <input type="checkbox"/> <input type="checkbox"/> <input type="checkbox"/> : <input type="checkbox"/> <input type="checkbox"/> <input type="checkbox"/> <input type="checkbox"/> <input type="checkbox"/> <input type="checkbox"/>	Clear from ROM correction data transfer processing

ROM DATA TRANSFER PROCESSES

When replacing front-end (A1) of mother unit (X34-), or when adding or replacing ROM correction (program correction with ROM IC (IC10)), the following activities are required.

■ Overview

When replacing front-end (A1) in the model where ROM correction and security data have been written into E2PROM, included in the front-end (A1) pack, the transfer function of the E2PROM data itself in the replaced front-end (A1) is required. This function in the above system configuration is used to allow for complete replacement of the front-end at any service center.

■ Overview of specifications

Procedures for replacement are as follows: To install the E2PROM to the mother unit (X34-), and replace front-end (A1) with new front-end after copying the data in the E2PROM (such as ROM correction data and other data) in the front-end (A1) to the mother unit (X34-) by operating the system, and then copy the data (such as ROM correction data and other data) into the mother unit to the E2PROM of the front-end (A1), operating the main body.

Tuner adjustment data was inserted during the tuner pack manufacturing, and data will not be transferred because front-end (A1) is built-in.

In addition, tuner adjustment data for new front-end (A1) is supplied as a service part in which data was inserted.

■ Data to be copied

- ROM correction data
- Other data
 - Security data
 - DEMO MODE ON/OFF status
 - POWER ON time (For maintenance)
 - Playback time (For maintenance)
 - EJECT count (For maintenance)
 - Panel open/close count (For maintenance)
 - CD I2C status (For maintenance)
 - CD offset error code (For maintenance)
 - CD sound skips count (For maintenance)
 - CD time code not updated count (For maintenance)
 - CD load switch errors count (For maintenance)
 - CD ejection errors count (For maintenance)
 - DC offset error (For maintenance)
 - Forced Power OFF information (For maintenance)
 - Serial number (For maintenance)
 - E2PROM data check data (For internal check)

■ Operation procedure

Operation procedure is different depending on the conditions. Proceed with the appropriate operation procedure depending on the specific condition.

1. In case of replacing front-end (A1) without an applicable ROM correction.
2. In case of replacing front-end (A1) with an applicable ROM correction.
3. In case of applying new ROM correction at the same time when front-end (A1) is replaced. (No ROM correction has been carried out.)

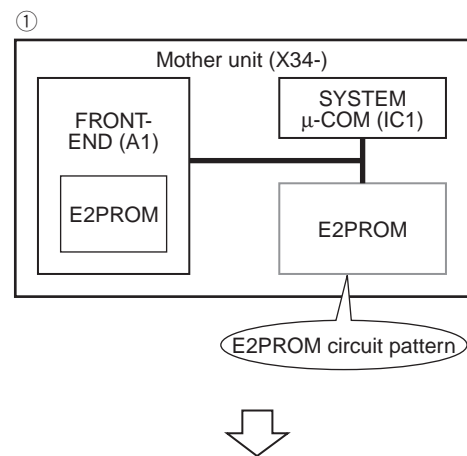

Install new E2PROM.

Install E2PROM containing no data, in case of [1] and [2].

In case of [3], install maintenance E2PROM with an applicable ROM correction program.

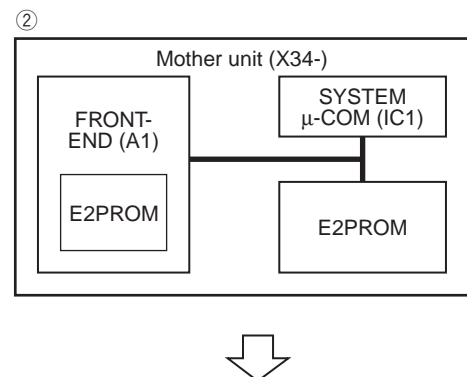

ROM DATA TRANSFER PROCESSES

Turn power on.

Press and hold the [1] and [3] keys and press reset button.
(Enter the system in the test mode.)

Press [B.BOOST] key. (ROM data System enters data transfer mode.)

Press [◀◀] (or ▶▶). (Select READ)

Press [▶▶] key for 1 second or longer. (Data transfer)

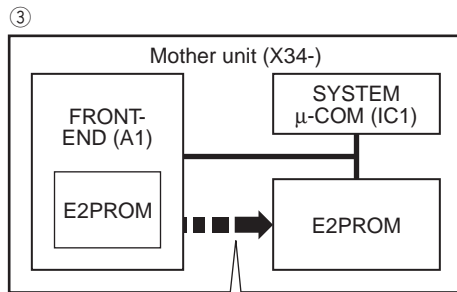

The system μ-COM (IC1) copies the data in the front-end (A1) in the E2PROM on the mother unit (X34-)

In case of [2]

READ OK R-OK

In case of [1] or [3]

READ OK2 R-O2



Press [▶▶] key. (Exit ROM data transfer mode.)

Turn power off.

Remove front-end (A1).

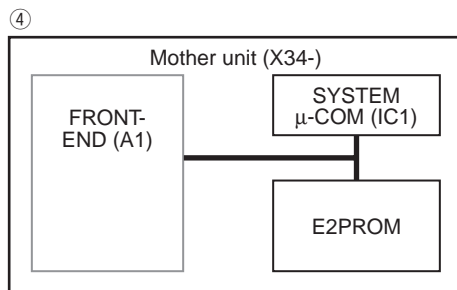

Install new front-end (A1).

No ROM correction or other data status.

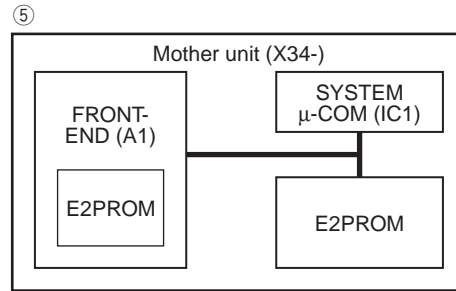

Turn power on.

Press and hold the [1] and [3] keys and press reset button.
(Enter the system in the test mode.)

Press [B.BOOST] key. (Start transferring ROM data.)

Press [◀◀] (or ▶▶). (Select WRT)

Press [▶▶] key for 1 second or longer. (Data transfer)

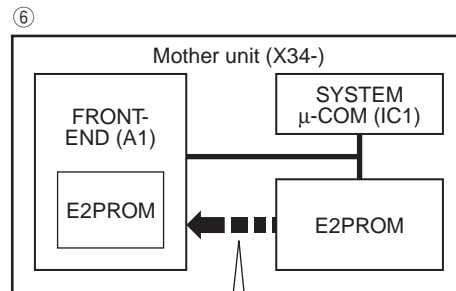

System μ-COM (IC1) copies data on the mother unit (X34-) into E2PROM in the front-end (A1)

In case of [2] or [3]

WRT OK W-OK

In case of [1]

WRT OK2 W-O2

Press [▶▶] key. (Exit ROM data transfer mode.)

ROM DATA TRANSFER PROCESSES

4. In case of applying a new ROM correction when front-end (A1) is replaced (There is ROM correction data.)
5. In case of applying a new ROM correction even when front-end (A1) is not replaced.

Turn power on.

Press and hold the [1] and [3] keys, press reset button. (Enter the system in the test mode.)

Press [B.BOOST] key. (ROM data System enters data transfer mode.)

Press [◀◀] (or ▶▶). (Select WRT)

Press [▶▶] key for 1 second or longer. (Data transfer)

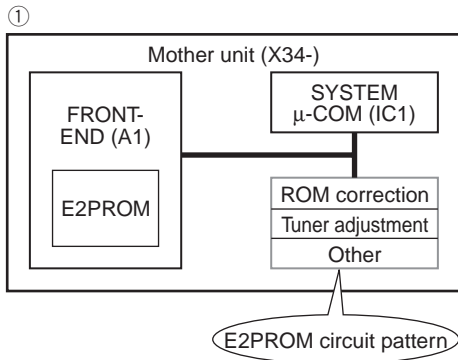

Install new E2PROM. (E2PROM that has been updated with ROM correction)

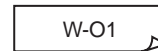
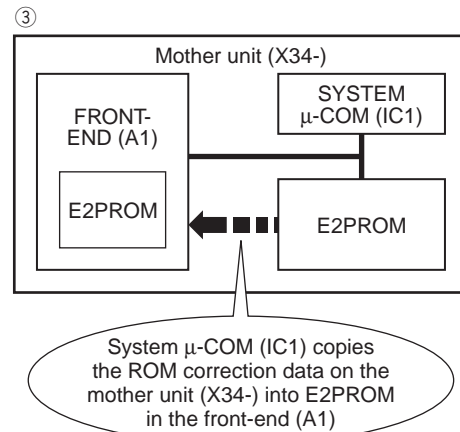
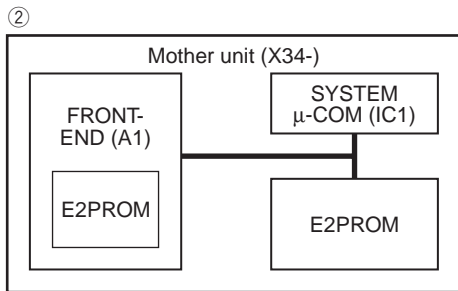

In case of [4]

In case of [5]

Press [▶▶] key. (Exit ROM data transfer mode.)

Press [◀◀] (or ▶▶). (Select READ)

Press [▶▶] key for 1 second or longer. (Data transfer)

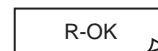
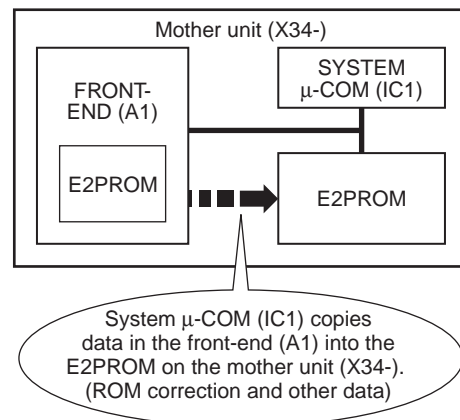

ROM DATA TRANSFER PROCESSES

Press [▶||] key. (Exit ROM data transfer mode.)
Turn power off.

Remove front-end (A1).

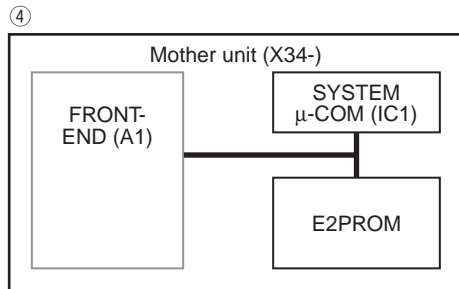

Install new front-end (A1).
No ROM correction or other data status.

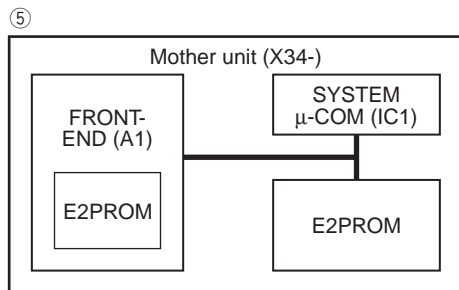

Turn power on.

Press and hold the [1] and [3] keys press reset button. (Enter the system in the test mode.)

Press [B.BOOST] key. (Enter the system in ROM data transfer mode.)

Press [◀◀] (or ▶▶.) (Select WRT)

Press [▶||] key for 1 second or longer. (Data transfer)

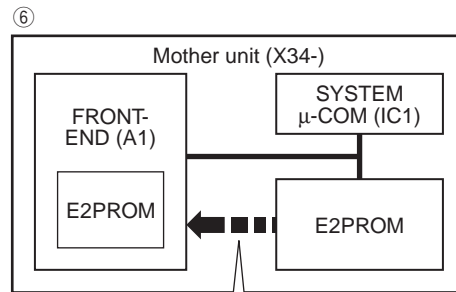

System μ-COM (IC1) copies data on the mother unit (X34-) into E2PROM in the front-end (A1)

WRT OK

W-OK

Press [▶||] key. (Exit ROM data transfer mode.)

PC BOARD (COMPONENT SIDE VIEW)

SWITCH UNIT

X16-386x-xx (J76-0360-02)

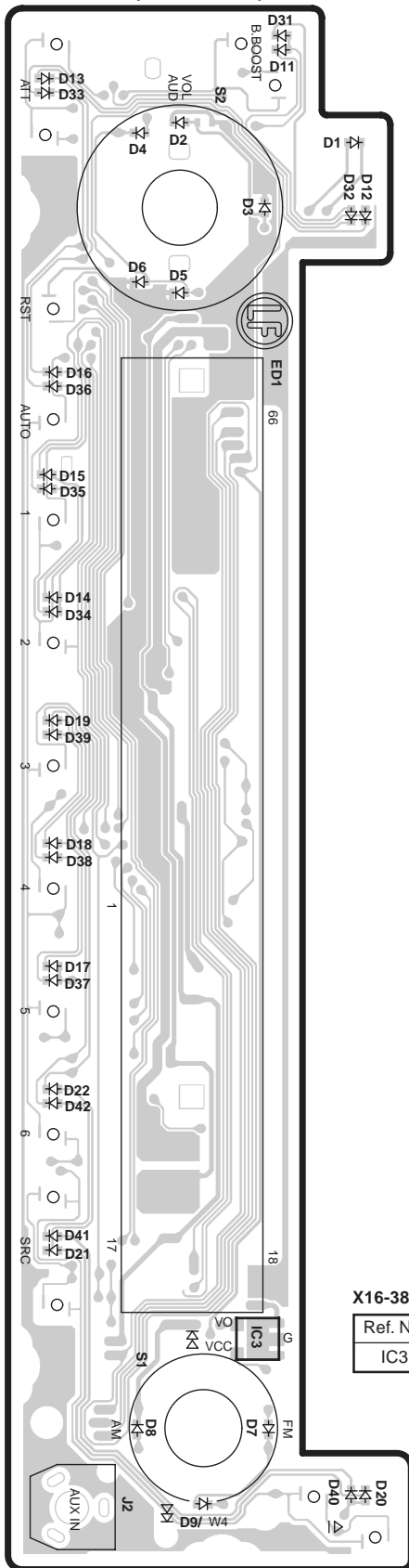

X16-386x-xx

Ref. No.	Address
IC3	6A

(FOIL SIDE VIEW)

SWITCH UNIT

X16-386x-xx (J76-0360-02)

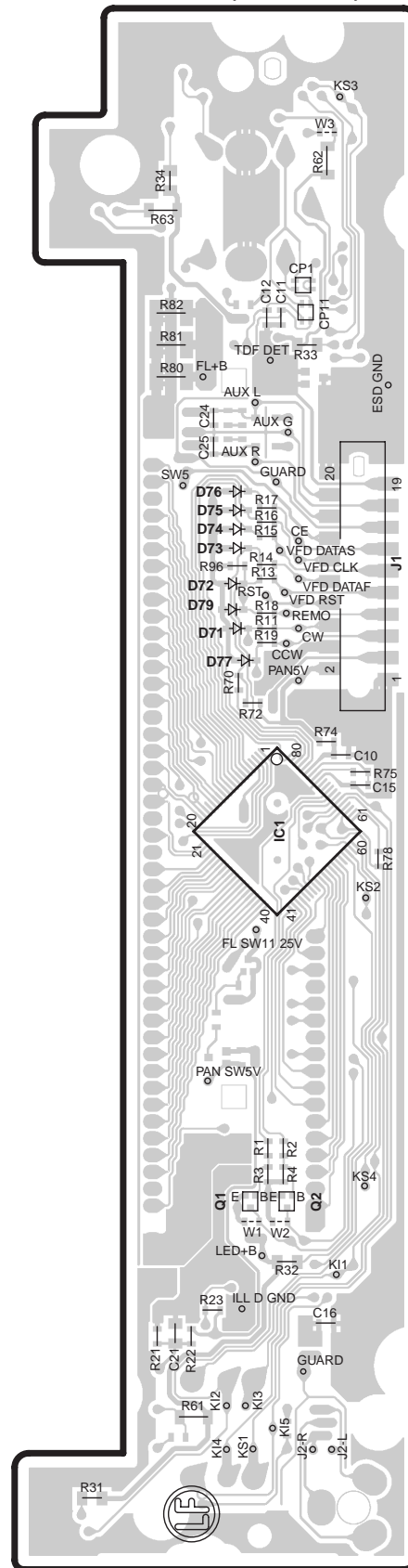

X16-386x-xx

Ref. No.	Address
IC1	4D
Q1	6D
Q2	6D

Refer to the schematic diagram for the values of resistors and capacitors.

PC BOARD (FOIL SIDE VIEW)

ELECTRIC UNIT X34-467x-xx (J76-0358-02)

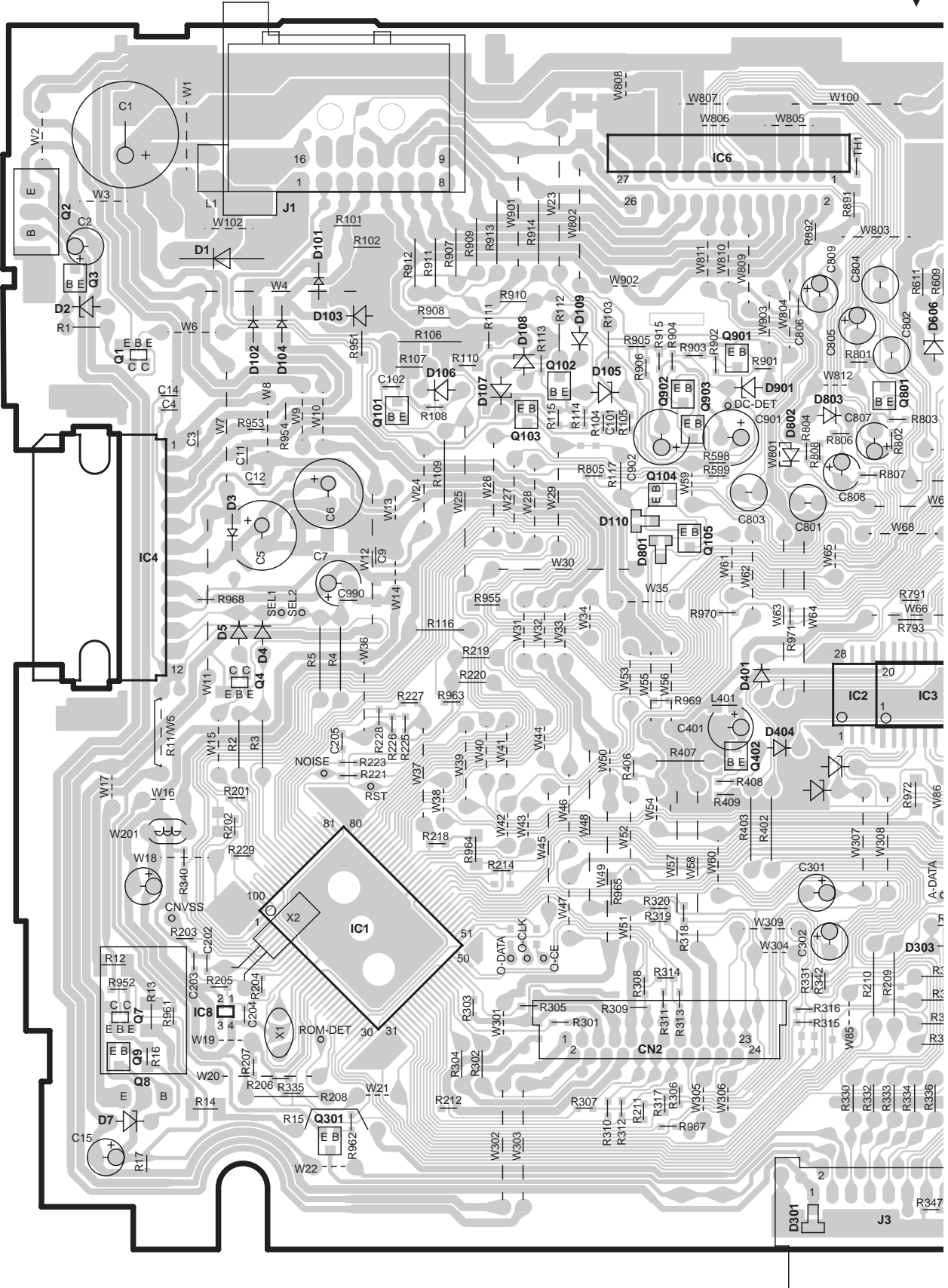

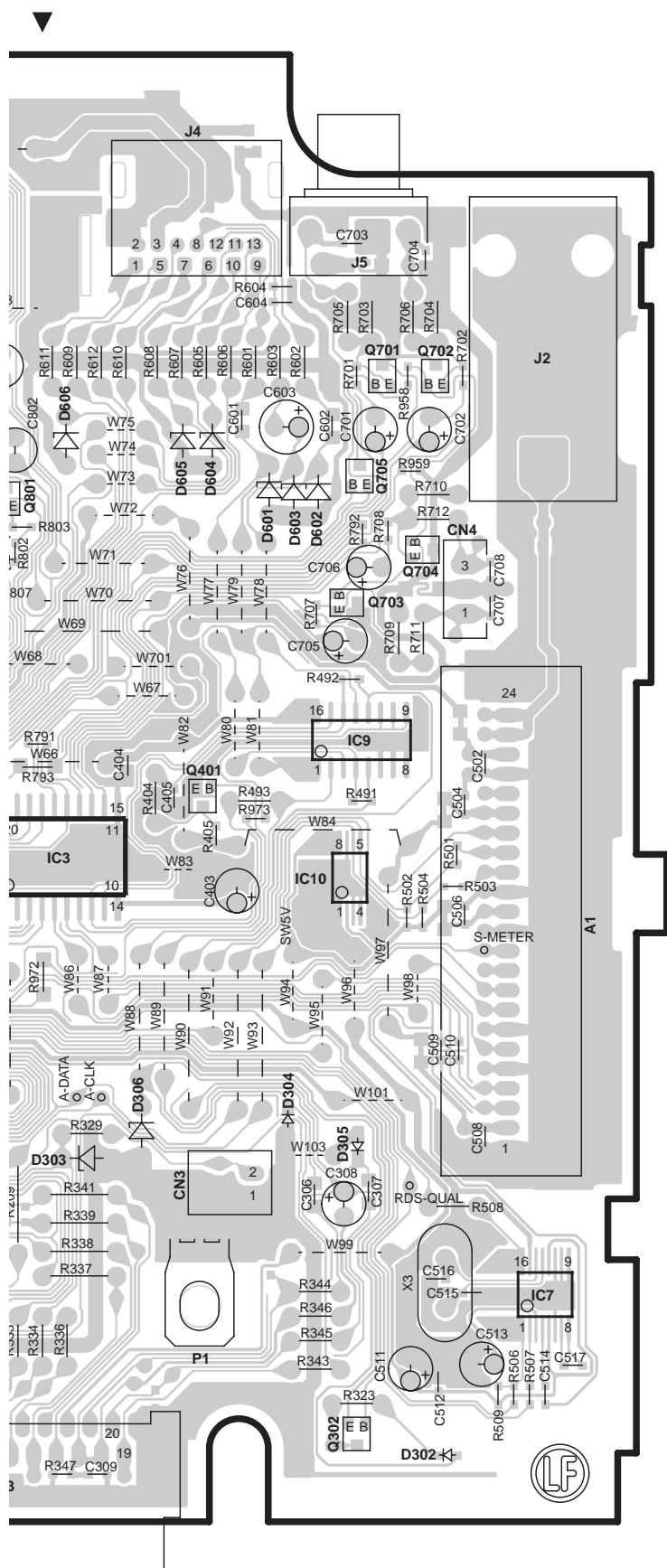

X34-467x-xx

Ref. No.	Address
IC1	5H
IC2	4J
IC3	4K
IC4	4G
IC6	2J
IC7	6M
IC8	6G
IC9	4L
Q1	3G
Q2	2G
Q3	3G
Q7	6G
Q8	6G
Q9	6G
Q101	3H
Q102	3I
Q103	3I
Q104	3I
Q105	4I
Q301	6H
Q302	7L
Q401	4K
Q402	5J
Q701	3L
Q702	3L
Q705	3L
Q901	3J
Q902	3I
Q903	3I

Refer to the schematic diagram for the values of resistors and capacitors.

KDC-W237AY/W237GY/W3037AY/W3037GY/
W311AY/W311GY/W3537AY/W3537GY/W4037Y

PC BOARD (COMPONENT SIDE VIEW)

CD PLAYER UNIT X32-5970-00 (J76-0366-02)

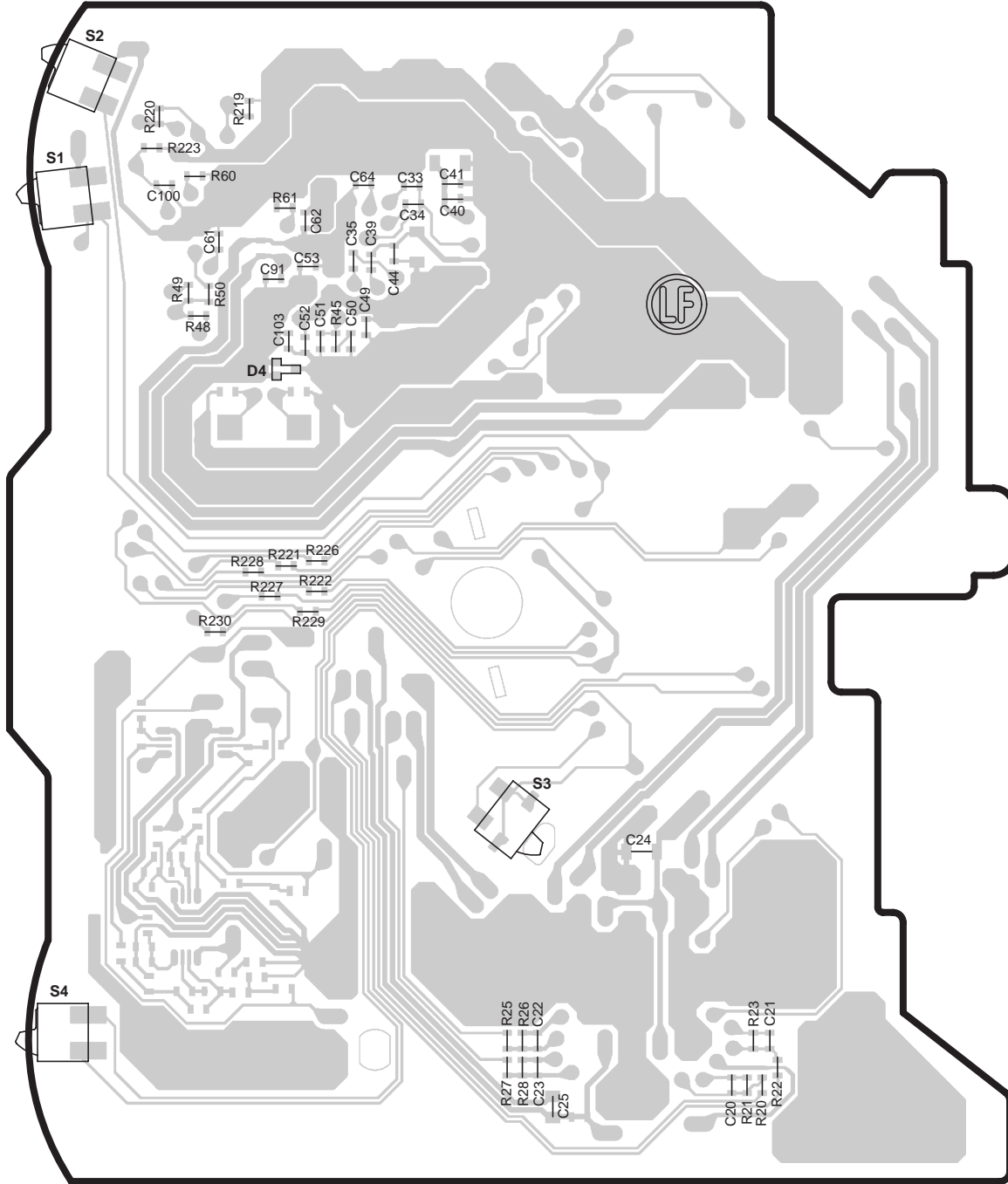

Refer to the schematic diagram for the values of resistors and capacitors.

PC BOARD (FOIL SIDE VIEW)

CD PLAYER UNIT X32-5970-00 (J76-0366-02)

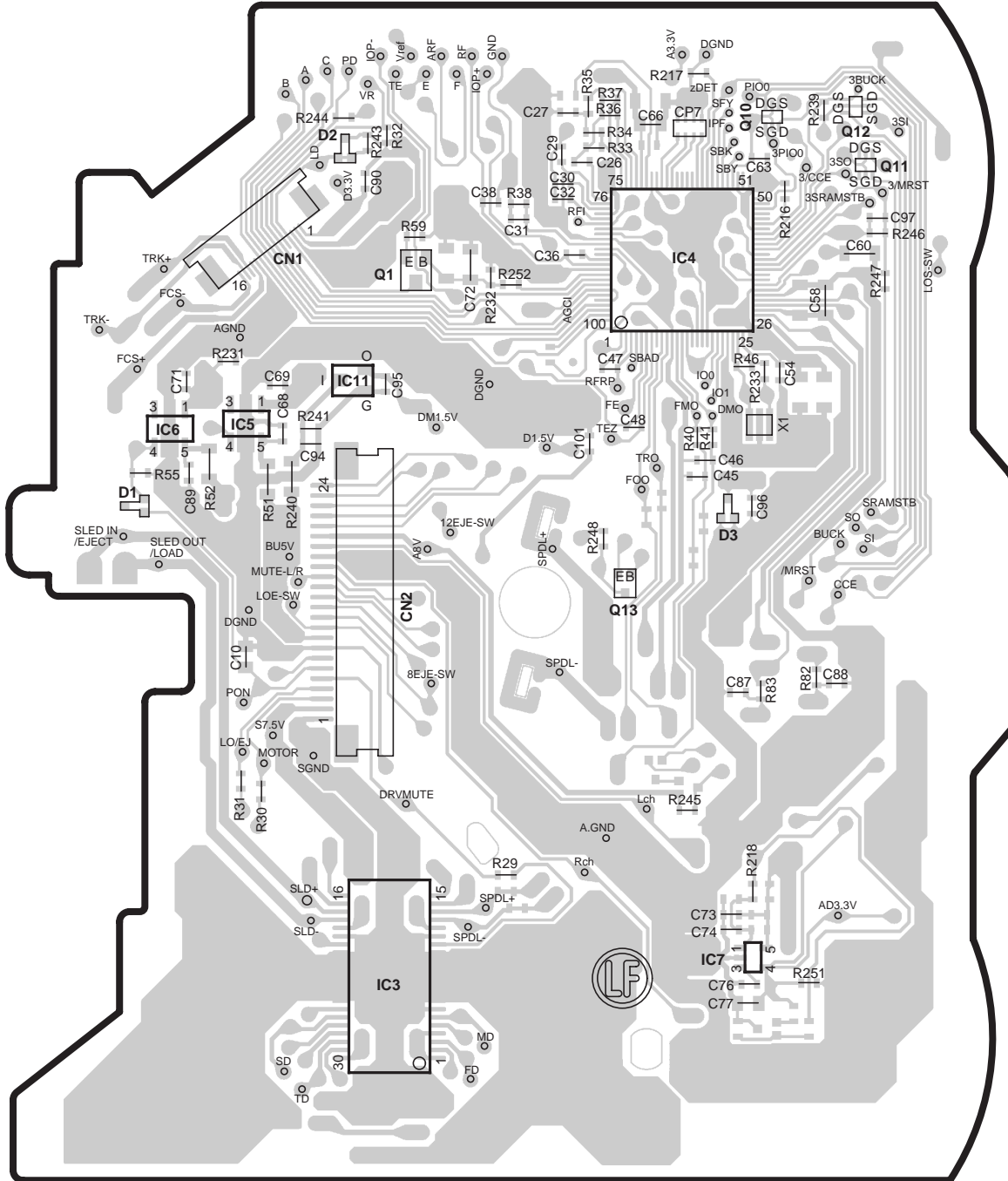

X32-5970-00

Ref. No.	Address	Ref. No.	Address
IC3	5V	Q1	2V
IC4	2W	Q10	2X
IC5	3V	Q11	2X
IC6	3U	Q12	2X
IC7	5X	Q13	4W
IC11	3V		

Refer to the schematic diagram for the values of resistors and capacitors.

ELECTRIC UNIT (X34-46xx-xx)

2SB1565

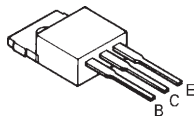

DTC114YUA
 2SA1576A
 2SC4617



2SC4081

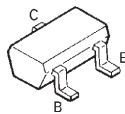

UMC2N

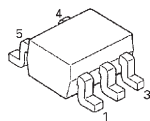

DAP202U
 DA204U

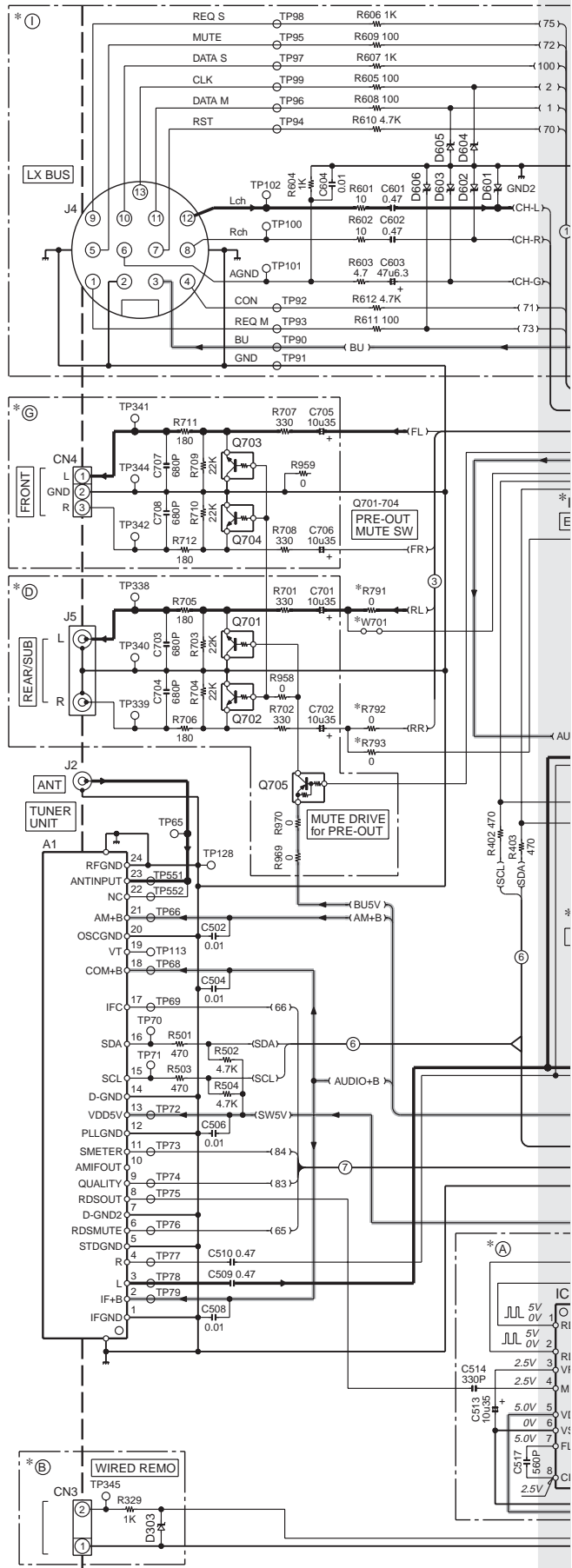

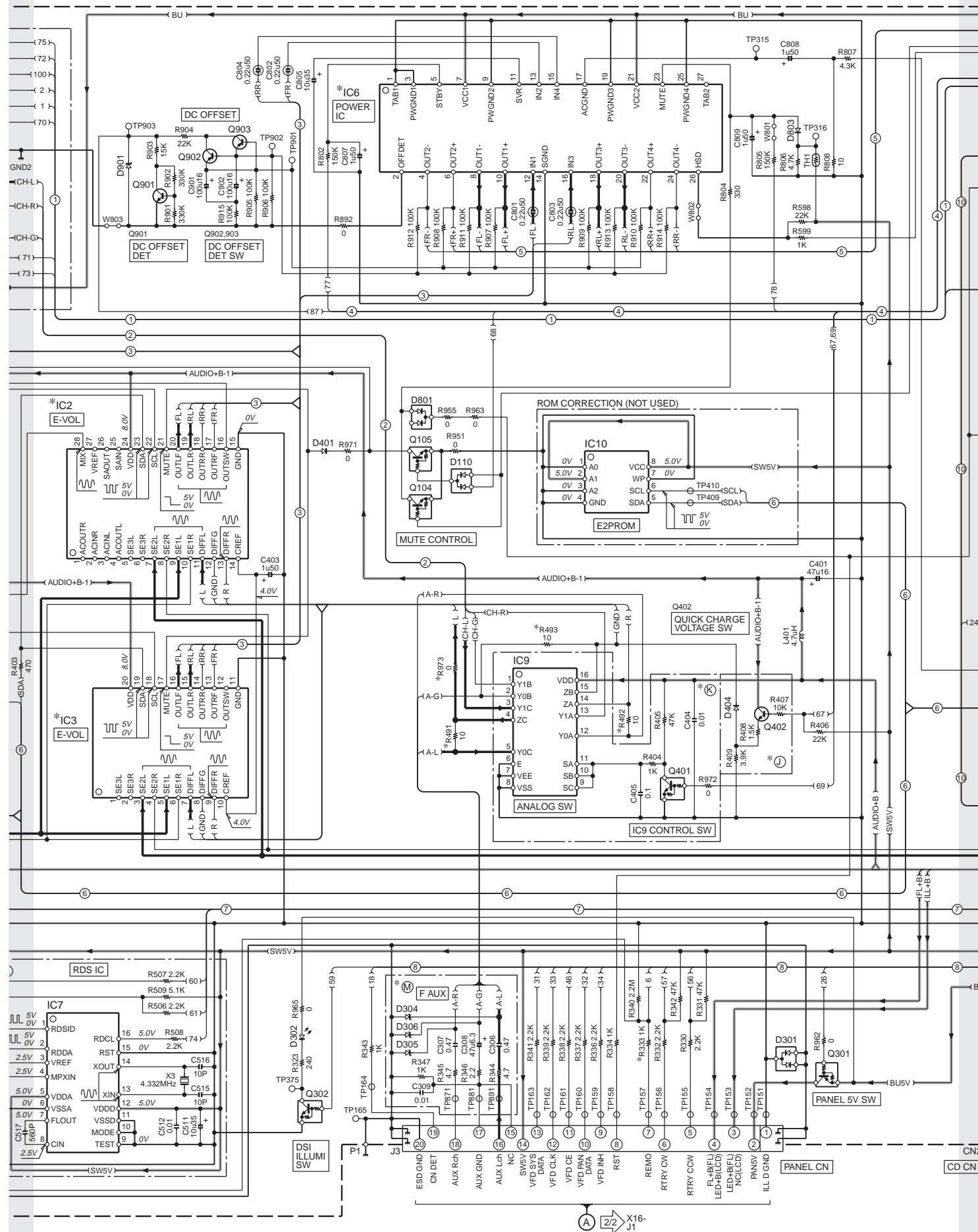

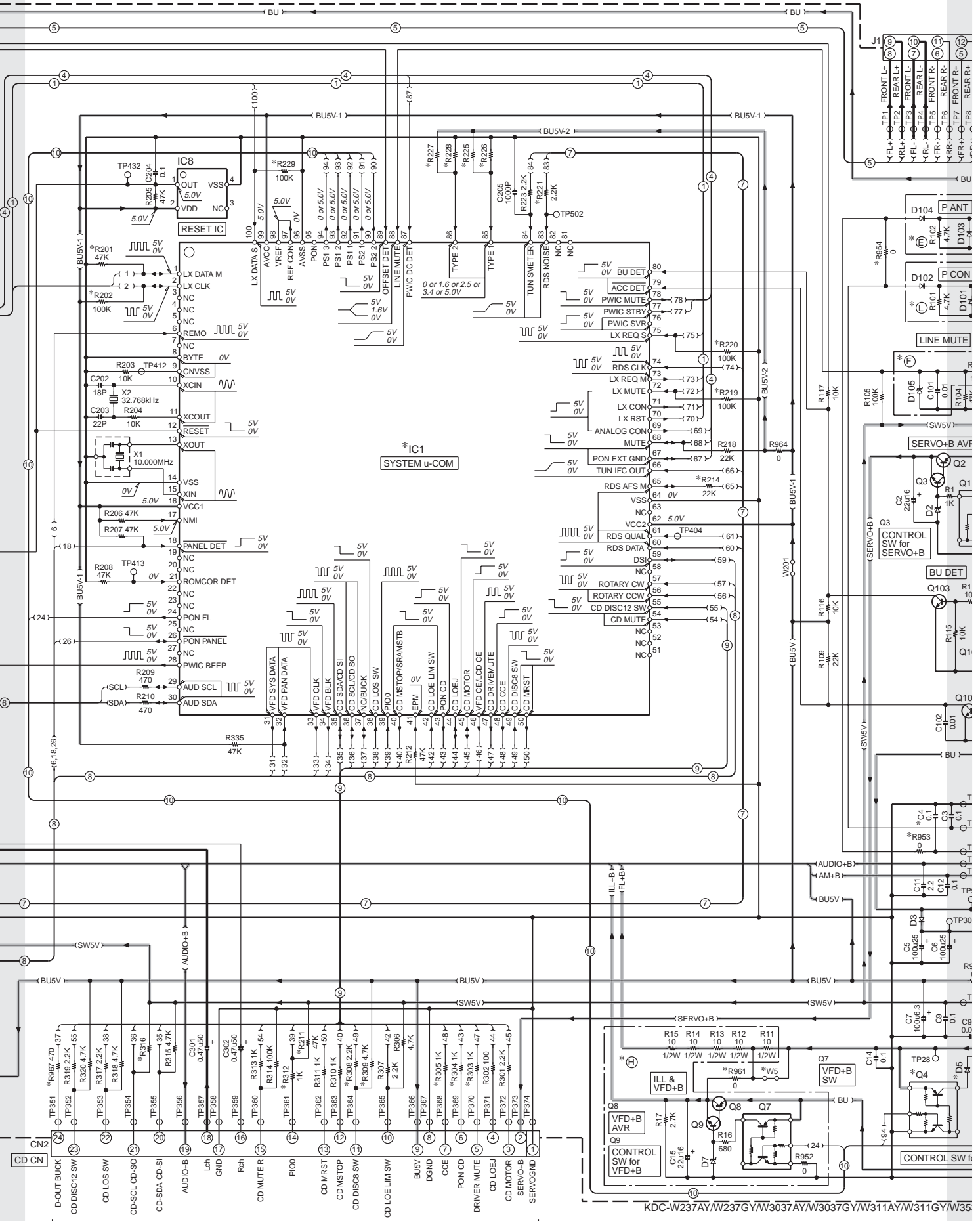

ANODE CONNECTION

PIN NAME	3GA,3GB	2G	1GA,1GB
P1	—	col (Downside)	S1
P2	2d	2d	2d
P3	1d	1d	1d
P4	2n	2n	2n
P5	1n	1n	1n
P6	2p	2p	2p
P7	1p	1p	1p
P8	2r	2r	2r
P9	1r	1r	1r
P10	2e	2e	2e
P11	1e	1e	1e
P12	2c	2c	2c
P13	1c	1c	1c
P14	2g	2g	2g
P15	1g	1g	1g
P16	2m	2m	2m
P17	1m	1m	1m
P18	2f	2f	2f
P19	1f	1f	1f
P20	2a	2a	2a
P21	1a	1a	1a
P22	2h	2h	2h
P23	1h	1h	1h
P24	2j	2j	2j
P25	1j	1j	1j
P26	2k	2k	2k
P27	1k	1k	1k
P28	2b	2b	2b
P29	1b	1b	1b
P30		col (Upside)	S2
P31		—	S3
P32		—	S4
P33		—	S5
P34	—	—	S6
P35	col	Dp	S7
P36	3d	3d	S8
P37	3n	3n	S9
P38	3p	3p	S10
P39	3r	3r	PTY
P40	3e	3e	
P41	3c	3c	
P42	3g	3g	
P43	3m	3m	d
P44	3f	3f	e
P45	3b	3b	c
P46	3k	3k	g
P47	3j	3j	f
P48	3h	3h	b
P49	3a	3a	a

(3GB/1GB/3GA/2G)

(1GA)

SWITCH UNIT (X16-386x-xx)

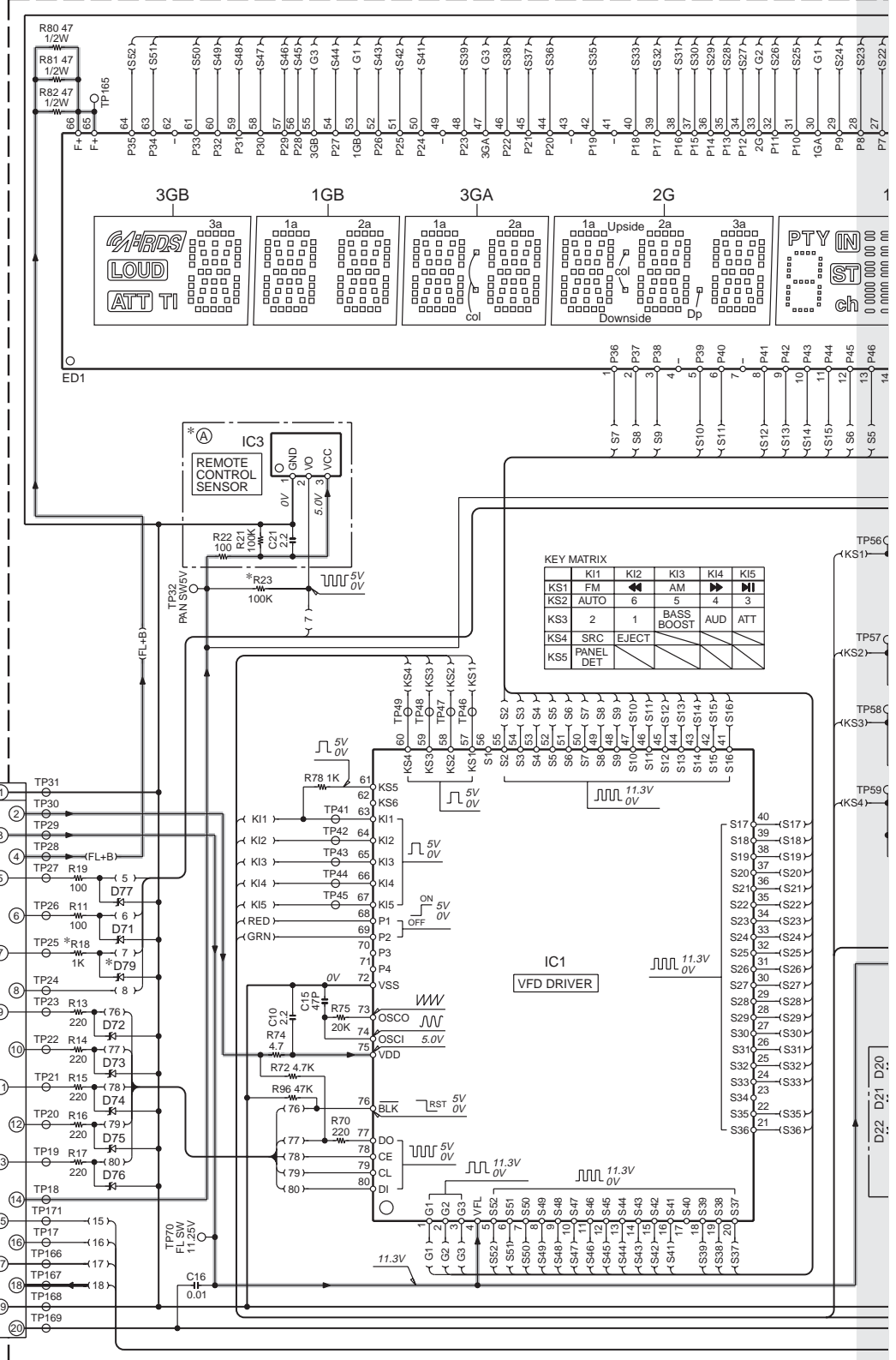

KEY MATRIX

	K11	K12	K13	K14	K15
KS1	FM	◀	AM	▶	MI
KS2	AUTO	6	5	4	3
KS3	2	1	BASS BOOST	AUD	ATT
KS4	SRC	EJECT			
KS5	PANEL DET				

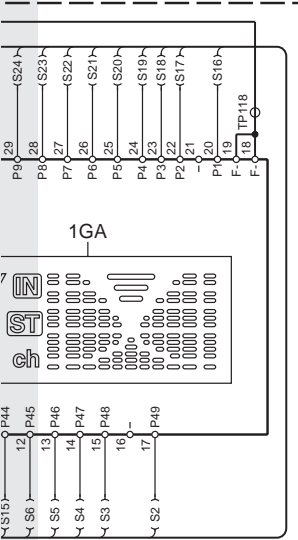
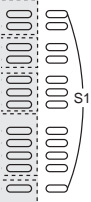

SWITCH UNIT (X16-386x-xx)

MODEL NAME	DESI-TINATION	UNIT No.	(A)	(C)	(D)	C24, 25	D2,5	D3,4,6,9	D7,8	D79	J2	Q1, 2	R1-4	R18	R23	R61	R62	W1	W2	W3, 4
E222/S	J1/J2	X16-3860-01	--	--	B30-1575-05	YES	YES	--	B30-1767-05	--	E11-0650-05	--	--	--	--	560	820	YES	--	YES
E323S	J	X16-3860-01	--	--	B30-1575-05	YES	YES	--	B30-1767-05	--	E11-0650-05	--	--	--	--	560	820	YES	--	YES
KDC-MP2035	K	X16-3860-10	YES	YES	--	YES	YES	--	B30-1767-05	YES	E11-0650-05	--	YES	--	YES	560	820	--	YES	YES
KDC-MP205	K2	X16-3862-73	--	YES	--	YES	--	B30-1566-05	B30-1566-05	YES	E11-0649-05	--	--	YES	YES	470	680	--	YES	--
KDC-MP235	K1	X16-3860-10	YES	YES	--	YES	YES	--	B30-1767-05	YES	E11-0650-05	--	YES	--	YES	560	820	--	YES	YES
KDC-MP235CR	K3	X16-3862-75	YES	YES	B30-1565-05	YES	--	B30-1566-05	B30-1566-05	YES	E11-0649-05	--	YES	--	YES	470	680	--	YES	--
KDC-MP3036	M9	X16-3860-22	YES	--	B30-1565-05	--	--	B30-1565-05	B30-1565-05	YES	--	--	--	YES	YES	470	680	YES	--	--
KDC-MP3036AX	M8	X16-3862-76	YES	--	B30-1565-05	YES	--	B30-1565-05	B30-1565-05	YES	E11-0649-05	--	--	YES	YES	470	680	YES	--	--
KDC-MP336/RC/S	M6/M5/M7	X16-3860-22	YES	--	B30-1565-05	--	--	B30-1565-05	B30-1565-05	YES	--	--	--	YES	YES	470	680	YES	--	--
KDC-MP336AX/AXS	M3/M4	X16-3862-76	YES	--	B30-1565-05	YES	--	B30-1565-05	B30-1565-05	YES	E11-0649-05	--	--	YES	YES	470	680	YES	--	--
KDC-MP4036AX	M1	X16-3860-21	YES	--	B30-1565-05	YES	YES	--	B30-1767-05	YES	E11-0650-05	--	--	YES	YES	560	820	YES	--	YES
KDC-MP436AX	M2	X16-3862-76	YES	--	B30-1565-05	YES	--	B30-1565-05	B30-1565-05	YES	E11-0649-05	--	--	YES	YES	470	680	YES	--	--
KDC-237SA/SAY	E1/E3	X16-3862-73	--	YES	--	YES	--	B30-1566-05	B30-1566-05	YES	E11-0649-05	--	--	YES	YES	470	680	--	YES	--
KDC-237SG/SGY	E2/E4	X16-3862-74	--	--	B30-1565-05	YES	--	B30-1565-05	B30-1565-05	YES	E11-0650-05	--	--	YES	YES	470	680	YES	--	--
KDC-W237A/AY	E7/E7	X16-3862-73	--	YES	--	YES	--	B30-1566-05	B30-1566-05	YES	E11-0649-05	--	--	YES	YES	470	680	--	YES	--
KDC-W237G/GY	E8/E8	X16-3862-74	--	--	B30-1565-05	YES	--	B30-1565-05	B30-1565-05	YES	E11-0650-05	--	--	YES	YES	470	680	YES	--	--
KDC-W3037A/AY	E3/E3	X16-3862-73	--	YES	--	YES	--	B30-1566-05	B30-1566-05	YES	E11-0649-05	--	--	YES	YES	470	680	--	YES	--
KDC-W3037G/GY	E4/E4	X16-3862-74	--	--	B30-1565-05	YES	--	B30-1565-05	B30-1565-05	YES	E11-0650-05	--	--	YES	YES	470	680	YES	--	--
KDC-W311A/AY	E5/E5	X16-3862-73	--	YES	--	YES	--	B30-1566-05	B30-1566-05	YES	E11-0649-05	--	--	YES	YES	470	680	--	YES	--
KDC-W311G/GY	E6/E6	X16-3862-74	--	--	B30-1565-05	YES	--	B30-1565-05	B30-1565-05	YES	E11-0650-05	--	--	YES	YES	470	680	YES	--	--
KDC-W3537A/AY	E1/E1	X16-3862-75	YES	YES	--	YES	--	B30-1566-05	B30-1566-05	YES	E11-0649-05	--	--	YES	YES	470	680	--	YES	--
KDC-W3537G/GY	E2/E2	X16-3862-76	YES	--	B30-1565-05	YES	--	B30-1565-05	B30-1565-05	YES	E11-0649-05	--	--	YES	YES	470	680	YES	--	--
KDC-W4037Y	E/E	X16-3862-72	YES	YES	B30-1565-05	YES	YES	--	B30-1767-05	YES	E11-0649-05	YES	YES	YES	--	560	820	--	--	YES

- ED1 : 3-BT-224N D1,11-22: B30-1566-05
- D3,4,6-9,31-42
- IC1 : LC75756W D2,5 : *
- IC3 : PNA4S22M02KW D71-77,79 : UDZ5S.6B
- Q1,2 : 2SC4617

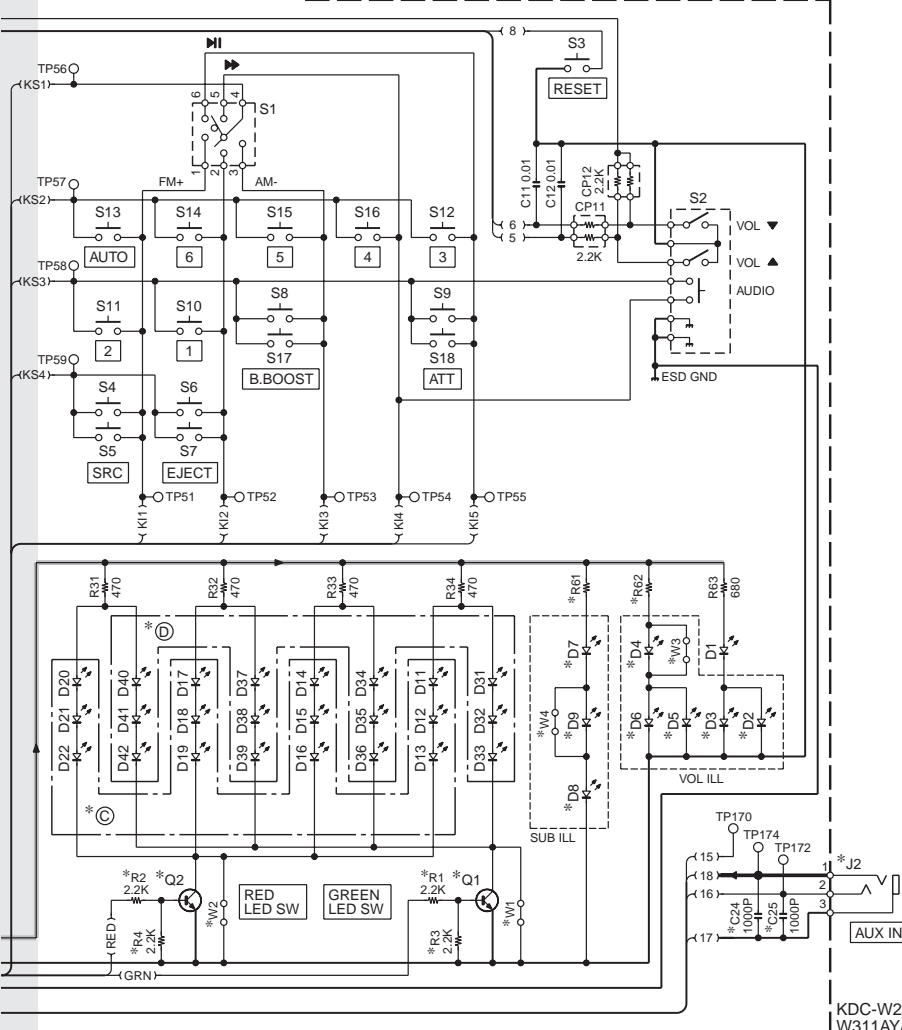

CAUTION : For continued safety, replace safety critical components only with manufacturer's recommended parts (refer to parts list).
 ⚠ Indicates safety critical components. To reduce the risk of electric shock, leakage-current or resistance measurements shall be carried out (exposed parts are acceptably insulated from the supply circuit) before the appliance is returned to the customer.

- DC voltages are as measured with a high impedance voltmeter. Values may vary slightly due to variations between individual instruments or/and units.

KDC-W237AY/W237GY/W3037AY/W3037GY/
W311AY/W311GY/W3537AY/W3537GY/W4037Y (2/2)

KDC-W237AY/W237GY/W3037AY/W3037GY/
W311AY/W311GY/W3537AY/W3537GY/W4037Y

CD PLAYER UNIT (X32-597x-xx)

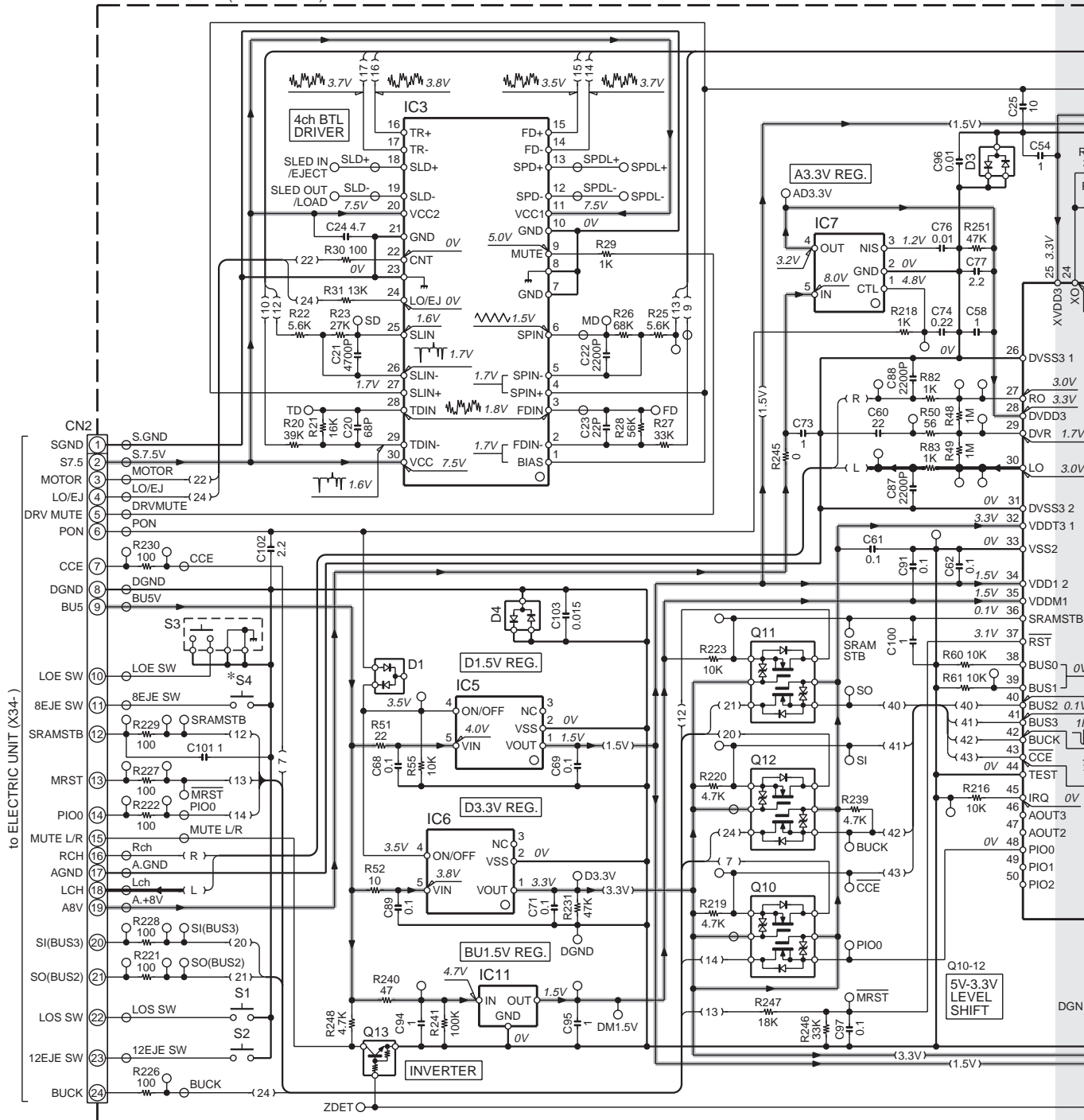

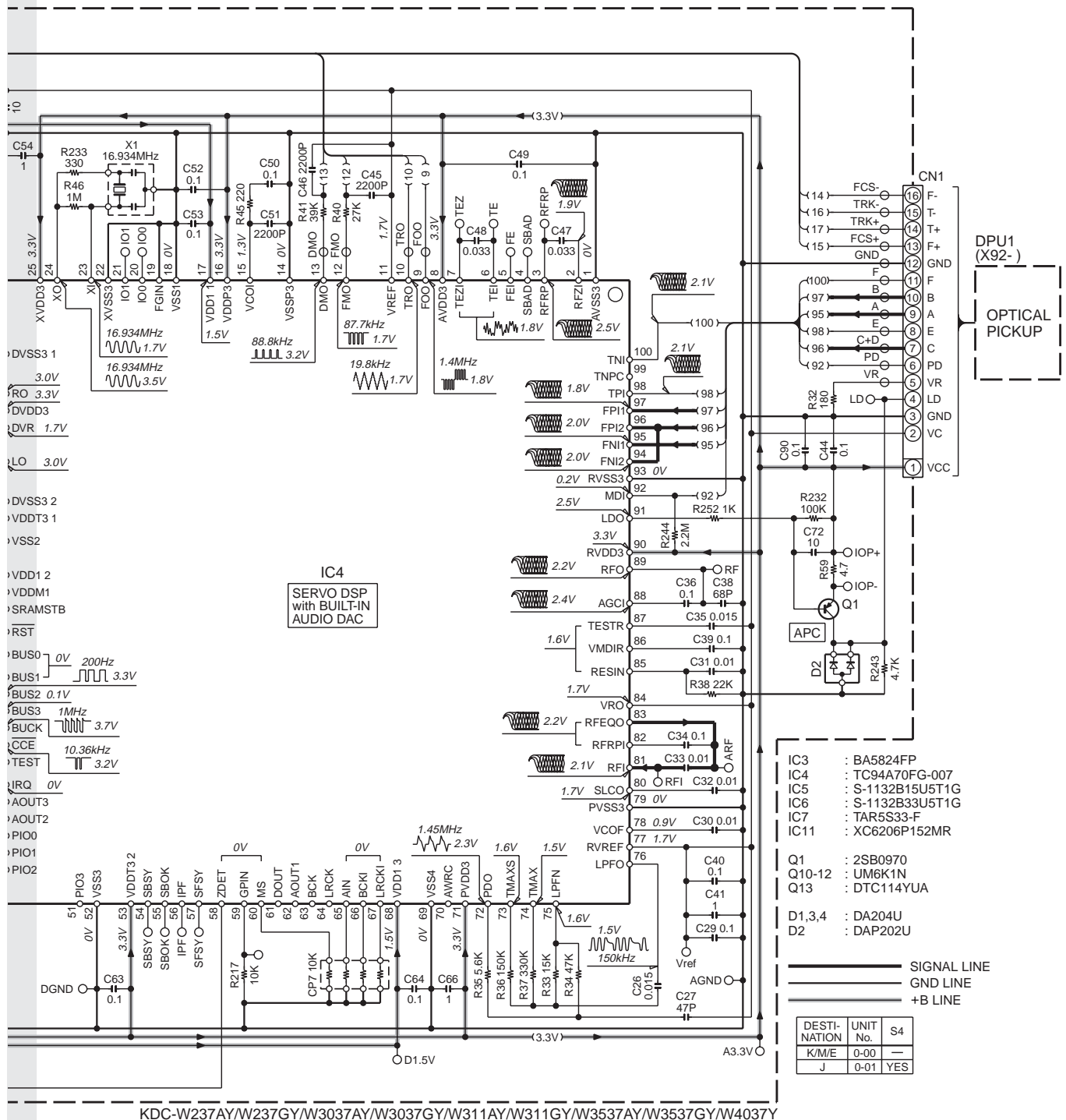

- IC3 : BA5824FP
- IC4 : TC94A70FG-007
- IC5 : S-1132B15U5T1G
- IC6 : S-1132B33U5T1G
- IC7 : TAR5S33-F
- IC11 : XC6206P152MR

- Q1 : 2SB0970
- Q10-12 : UM6K1N
- Q13 : DTC114YUA

- D1,3,4 : DA204U
- D2 : DAP202U

DESTINATION	UNIT No.	S4
K/M/E	0-00	—
J	0-01	YES

KDC-W237AY/W237GY/W3037AY/W3037GY/W311AY/W311GY/W3537AY/W3537GY/W4037Y

CAUTION : For continued safety, replace safety critical components only with manufacturer's recommended parts (refer to parts list).
 ⚠ Indicates safety critical components. To reduce the risk of electric shock, leakage-current or resistance measurements shall be carried out (exposed parts are acceptably insulated from the supply circuit) before the appliance is returned to the customer.

- DC voltages are as measured with a high impedance voltmeter. Values may vary slightly due to variations between individual instruments or/and units.

EXPLODED VIEW (CD MECHANISM)

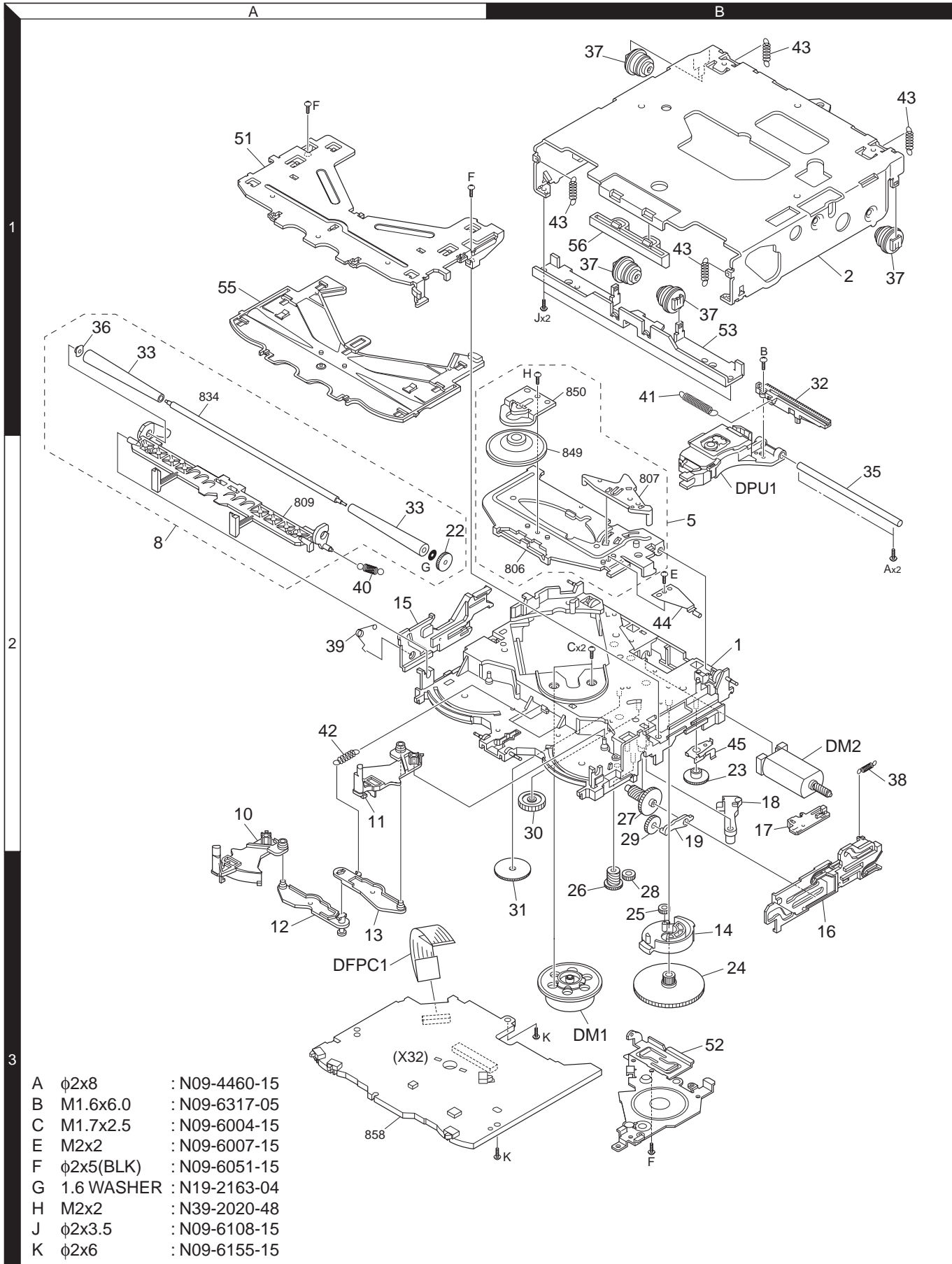

EXPLODED VIEW (UNIT)

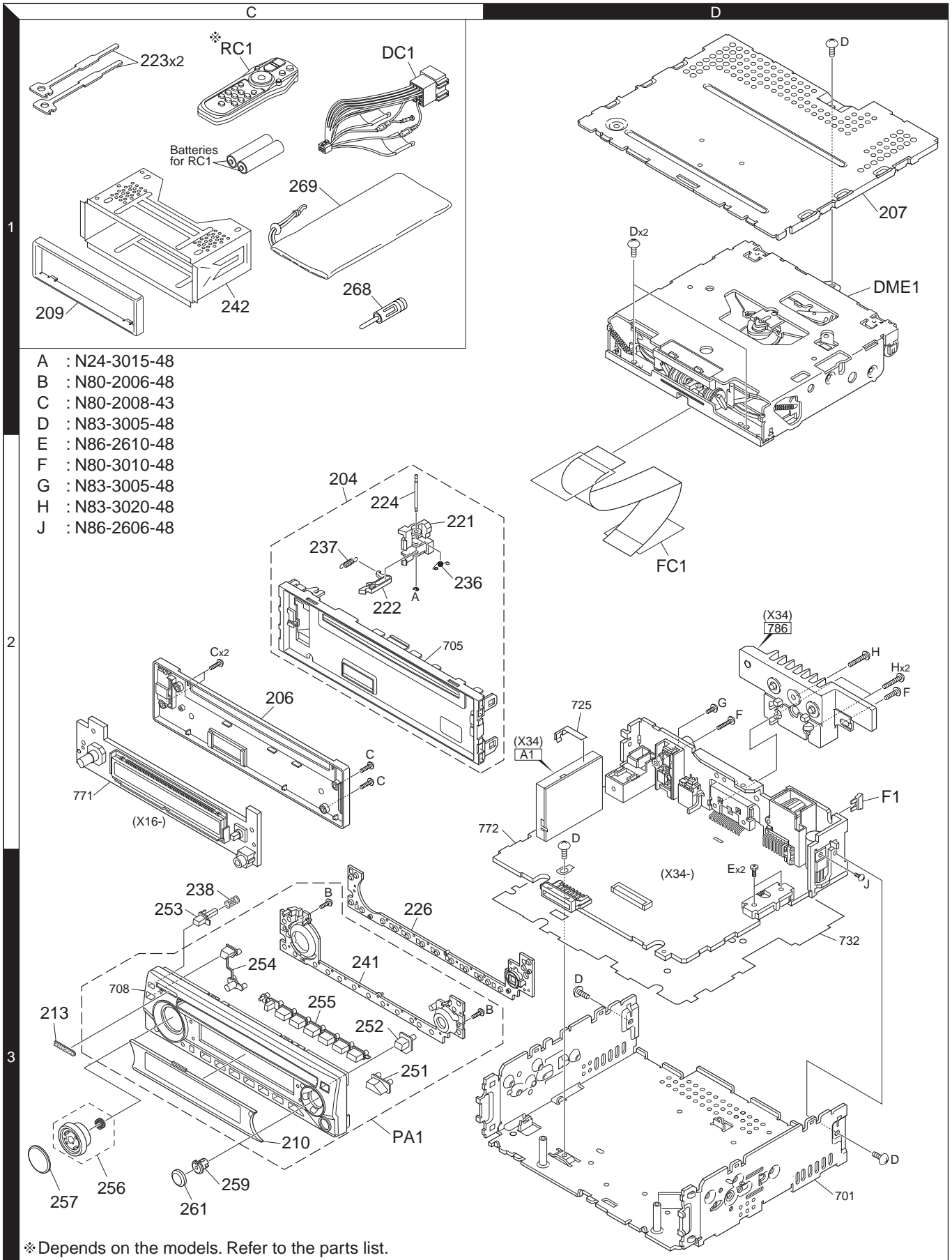

Parts with the exploded numbers larger than 700 are not supplied.

PARTS LIST

* New parts

Parts without **Parts No.** are not supplied.

Les articles non mentionnés dans le **Parts No.** ne sont pas fournis.

Teile ohne **Parts No.** werden nicht geliefert.

Ref. No.	A d d	N e w	Parts No.	Description	Desti- nation
KDC-W237/W3037/W311/W3537/W4037					
204	2C	*	A22-3117-13	SUB PANEL ASSY	
206	2C	*	A46-1846-11	REAR COVER	
207	1D		A52-0804-12	TOP PLATE	
PA1	3C	*	A64-4038-12	PANEL ASSY	E
PA1	3C	*	A64-4042-12	PANEL ASSY	E1E2
PA1	3C	*	A64-4056-12	PANEL ASSY	E3E4
PA1	3C	*	A64-4057-12	PANEL ASSY	E5E6
PA1	3C	*	A64-4058-02	PANEL ASSY	E7E8
RC1	1C	*	A70-2087-05	REMOTE CONTROLLER ASSY (RC-557)	EE1E2
-			B46-0612-14	ID CARD	EE1E2
-			B46-0681-04	ID CARD	E3E4E5
-			B46-0681-04	ID CARD	E6E7E8
-		*	B64-3496-00	INST. MANUAL (ENGLISH)	
-		*	B64-3498-00	INST. MANUAL (RUSSIAN)	
209	1C		B07-3122-01	ESCUTCHEON	EE1E2
209	1C		B07-3122-01	ESCUTCHEON	E3E4E7
209	1C		B07-3122-01	ESCUTCHEON	E8
209	1C		B07-3123-01	ESCUTCHEON	E5E6
210	3C	*	B10-4908-11	FRONT GLASS	E
210	3C	*	B10-4912-11	FRONT GLASS	E1E2
210	3C	*	B10-4924-11	FRONT GLASS	E3E4
210	3C	*	B10-4925-11	FRONT GLASS	E5E6
210	3C	*	B10-4926-01	FRONT GLASS	E7E8
213	3C		B43-1518-04	BADGE	
221	2C		D10-4446-03	LEVER	
222	2C		D10-4447-03	LEVER	
223	1C		D10-4589-04	LEVER	
224	2C		D21-2329-04	SHAFT	
226	3C	*	E29-2089-02	CONDUCTIVE RUBBER	
△ DC1	1C		E30-6427-05	DC CORD	
FC1	2D		E39-0736-05	FLAT CABLE (24-PIN)	
△ F1	2D		F52-0023-05	FUSE (MINI BLADE TYPE) (10A)	
236	2C		G01-2987-04	TORSION COIL SPRING	
237	2C		G01-3096-04	EXTENSION SPRING	
238	3C		G01-3244-04	COMPRESSION SPRING (REL)	
-		*	H54-3935-03	ITEM CARTON CASE	E
-		*	H54-3936-03	ITEM CARTON CASE	E1
-		*	H54-3937-03	ITEM CARTON CASE	E2
-		*	H54-3938-03	ITEM CARTON CASE	E3
-		*	H54-3939-03	ITEM CARTON CASE	E4
-		*	H54-3940-03	ITEM CARTON CASE	E5
-		*	H54-3941-03	ITEM CARTON CASE	E6
-		*	H54-3942-03	ITEM CARTON CASE	E7
-		*	H54-3943-03	ITEM CARTON CASE	E8
241	3C	*	J19-7158-01	HOLDER	
242	1C		J21-9716-03	MOUNTING HARDWARE ASSY	
251	3C	*	K24-4653-04	PUSH KNOB (SRC)	
252	3C	*	K24-4652-04	PUSH KNOB (EJECT)	
253	3C	*	K24-4654-04	PUSH KNOB (RELEASE)	
254	3C	*	K25-1860-03	PUSH KNOB (MENU/ATT)	
255	3C	*	K25-1859-02	PUSH KNOB (PRESET)	

Ref. No.	A d d	N e w	Parts No.	Description	Desti- nation
256	3C	*	K28-0201-03	KNOB ASSY (VOL)	
257	3C	*	K28-0190-03	KEY TOP (VOL)	E
257	3C	*	K28-0191-03	KEY TOP (VOL)	E1E2E3
257	3C	*	K28-0191-03	KEY TOP (VOL)	E4E5E6
257	3C	*	K28-0191-03	KEY TOP (VOL)	E7E8
259	3C		K29-7141-03	KNOB BASE (FM/AM)	
261	3C	*	K28-0195-03	KEY TOP (FM/AM)	E
261	3C	*	K28-0196-03	KEY TOP (FM/AM)	E1E2E3
261	3C	*	K28-0196-03	KEY TOP (FM/AM)	E4E5E6
261	3C	*	K28-0196-03	KEY TOP (FM/AM)	E7E8
A	2C		N24-3015-48	E TYPE RETAINING RING	
B	3C		N80-2006-48	PAN HEAD TAPTITE SCREW	
C	2C		N80-2008-43	PAN HEAD TAPTITE SCREW	
D	1D		N83-3005-48	PAN HEAD TAPTITE SCREW	
E	3D		N86-2610-48	BINDING HEAD TAPTITE SCREW	
268	1C		T90-0523-05	ANTENNA ADAPTOR	
269	1C	*	W01-1685-05	CARRYING CASE	
DME1	1D	*	X92-5880-00	MECHANISM ASSY (DXM-6E00W)	
SWITCH UNIT (X16-386x-xx)					
D1			B30-1566-05	LED (1608,RED)	
D2		*	B30-1767-05	LED	E
D3,4			B30-1565-05	LED (1608,PG)	E2E4E6
D3,4			B30-1565-05	LED (1608,PG)	E8
D3,4			B30-1566-05	LED (1608,RED)	E1E3E5
D3,4			B30-1566-05	LED (1608,RED)	E7
D5		*	B30-1767-05	LED	E
D6-9			B30-1565-05	LED (1608,PG)	E2E4E6
D6-9			B30-1565-05	LED (1608,PG)	E8
D6-9			B30-1566-05	LED (1608,RED)	E1E3E5
D6-9			B30-1566-05	LED (1608,RED)	E7
D7,8		*	B30-1767-05	LED	E
D11-22			B30-1566-05	LED (1608,RED)	EE1E3
D11-22			B30-1566-05	LED (1608,RED)	E5E7
D31-42			B30-1565-05	LED (1608,PG)	EE2E4
D31-42			B30-1565-05	LED (1608,PG)	E6E8
C10			CK73GB0J225K	CHIP C 2.2UF K	
C11,12			CK73GB1H103K	CHIP C 0.010UF K	
C15			CC73GCH1H470J	CHIP C 47PF J	
C16			CK73GB1H103K	CHIP C 0.010UF K	
C21			CK73FB1A225K	CHIP C 2.2UF K	EE1E2
C24,25			CK73GB1H102K	CHIP C 1000PF K	
J1		*	E59-0852-05	RECTANGULAR PLUG	
J2		*	E11-0649-05	3.5D PHONE JACK	EE1E2
J2		*	E11-0649-05	3.5D PHONE JACK	E3E5E7
J2		*	E11-0650-05	3.5D PHONE JACK	E4E6E8
CP11,12			RK74GA1J222J	CHIP-COM 2.2K J 1/16W	
R1-4			RK73GB2A222J	CHIP R 2.2K J 1/10W	E
R11			RK73GB2A101J	CHIP R 100 J 1/10W	
R13-17			RK73GB2A221J	CHIP R 220 J 1/10W	
R18			RK73GB2A102J	CHIP R 1.0K J 1/10W	
R19			RK73GB2A101J	CHIP R 100 J 1/10W	

E : KDC-W4037Y E1 : KDC-W3537AY E2 : KDC-W3537GY E3 : KDC-W3037AY E4 : KDC-W3037GY
E5 : KDC-W311AY E6 : KDC-W311GY E7 : KDC-W237AY E8 : KDC-W237GY

△ Indicates safety critical components.

PARTS LIST

SWITCH UNIT (X16-386x-xx)

Ref. No.	Add	New	Parts No.	Description	Destination	Ref. No.	Add	New	Parts No.	Description	Destination
R21			RK73GB2A104J	CHIP R 100K J 1/10W	EE1E2	C45,46			CK73GB1H222K	CHIP C 2200PF K	
R22			RK73GB2A101J	CHIP R 100 J 1/10W	EE1E2	C47,48			CK73GB1H333K	CHIP C 0.033UF K	
R23			RK73GB2A104J	CHIP R 100K J 1/10W	E3E4E5	C49,50			CK73GB1H104K	CHIP C 0.10UF K	
R23			RK73GB2A104J	CHIP R 100K J 1/10W	E6E7E8	C51			CK73GB1H222K	CHIP C 2200PF K	
R31-34			RK73FB2B471J	CHIP R 470 J 1/8W		C52,53			CK73GB1H104K	CHIP C 0.10UF K	
R61			RK73EB2E471J	CHIP R 470 J 1/4W	E1E2E3	C54			CK73GB1A105K	CHIP C 1.0UF K	
R61			RK73EB2E471J	CHIP R 470 J 1/4W	E4E5E6	C58			CK73EB1E105K	CHIP C 1.0UF K	
R61			RK73EB2E471J	CHIP R 470 J 1/4W	E7E8	C60			CK73EB0J226K	CHIP C 22UF K	
R61			RK73EB2E561J	CHIP R 560 J 1/4W	E	C61-64			CK73GB1H104K	CHIP C 0.10UF K	
R62			RK73EB2E821J	CHIP R 820 J 1/4W	E	C66			CK73FB1C105K	CHIP C 1.0UF K	
R62,63			RK73EB2E681J	CHIP R 680 J 1/4W	E1E2E3	C68,69			CK73GB1H104K	CHIP C 0.10UF K	
R62,63			RK73EB2E681J	CHIP R 680 J 1/4W	E4E5E6	C71			CK73GB1H104K	CHIP C 0.10UF K	
R62,63			RK73EB2E681J	CHIP R 680 J 1/4W	E7E8	C72			CK73EB1A106K	CHIP C 10UF K	
R63			RK73EB2E681J	CHIP R 680 J 1/4W	E	C73			CK73GB1A105K	CHIP C 1.0UF K	
R70			RK73GB2A221J	CHIP R 220 J 1/10W		C74			CK73GB1C224K	CHIP C 0.22UF K	
R72			RK73GB2A472J	CHIP R 4.7K J 1/10W		C76			CK73GB1H103K	CHIP C 0.010UF K	
R74			RK73GB2A4R7J	CHIP R 4.7 J 1/10W		C77			CK73FB1A225K	CHIP C 2.2UF K	
R75			RK73GB2A203J	CHIP R 20K J 1/10W		C87,88			CK73GB1H222K	CHIP C 2200PF K	
R78			RK73GB2A102J	CHIP R 1.0K J 1/10W		C89-91			CK73GB1H104K	CHIP C 0.10UF K	
R80-82			RK73PB2H470J	CHIP R 47 J 1/2W		C94,95			CK73GB1A105K	CHIP C 1.0UF K	
R96			RK73GB2A473J	CHIP R 47K J 1/10W		C96			CK73GB1H103K	CHIP C 0.010UF K	
W1			R92-1252-05	CHIP R 0 OHM J 1/16W	E2E4E6	C97			CK73GB1H104K	CHIP C 0.10UF K	
W1			R92-1252-05	CHIP R 0 OHM J 1/16W	E8	C100,101			CK73GB1A105K	CHIP C 1.0UF K	
W2			R92-1252-05	CHIP R 0 OHM J 1/16W	E1E3E5	C102			CK73FB1A225K	CHIP C 2.2UF K	
W2			R92-1252-05	CHIP R 0 OHM J 1/16W	E7	C103			CK73GB1H153K	CHIP C 0.015UF K	
W3,4			R92-1252-05	CHIP R 0 OHM J 1/16W	E	CN1			E41-2612-05	FLAT CABLE CONNECTOR	
S1			S70-0106-05	TACT SWITCH		CN2			E41-2083-15	FLAT CABLE CONNECTOR	
S2		*	T99-0474-05	ROTARY ENCODER		X1		*	L78-1221-05	RESONATOR (16.93MHZ)	
D71-77			UDZS5.6B	ZENER DIODE		CP7			RK74GB1J103J	CHIP-COM 10K J 1/16W	
D79			UDZS5.6B	ZENER DIODE		R20			RK73GB2A393J	CHIP R 39K J 1/10W	
ED1			3-BT-224N	FLUORESCENT INDICATOR TUBE		R21			RK73GB2A163J	CHIP R 16K J 1/10W	
IC1			LC75756W	MOS-IC		R22			RK73GB2A562J	CHIP R 5.6K J 1/10W	
IC3			PNA4S22M02KW	ANALOGUE IC	EE1E2	R23			RK73GB2A273J	CHIP R 27K J 1/10W	
Q1,2			2SC4617	TRANSISTOR	E	R25			RK73GB2A562J	CHIP R 5.6K J 1/10W	
CD PLAYER UNIT (X32-5970-00) IN CD MECHA						R26			RK73GB2A683J	CHIP R 68K J 1/10W	
C20			CC73GCH1H680J	CHIP C 68PF J		R27			RK73GB2A333J	CHIP R 33K J 1/10W	
C21			CK73GB1H472K	CHIP C 4700PF K		R28			RK73GB2A563J	CHIP R 56K J 1/10W	
C22			CK73GB1H222K	CHIP C 2200PF K		R29			RK73GB2A102J	CHIP R 1.0K J 1/10W	
C23			CC73GCH1H220J	CHIP C 22PF J		R30			RK73GB2A101J	CHIP R 100 J 1/10W	
C24			CK73EB1A475K	CHIP C 4.7UF K		R31			RK73GB2A133J	CHIP R 13K J 1/10W	
C25			CK73FB0J106K	CHIP C 10UF K		R32			RK73GB2A181J	CHIP R 180 J 1/10W	
C26			CK73GB1H153K	CHIP C 0.015UF K		R33			RK73GB2A153J	CHIP R 15K J 1/10W	
C27			CC73GCH1H470J	CHIP C 47PF J		R34			RK73GB2A473J	CHIP R 47K J 1/10W	
C29			CK73GB1H104K	CHIP C 0.10UF K		R35			RK73GB2A562J	CHIP R 5.6K J 1/10W	
C30-33			CK73GB1H103K	CHIP C 0.010UF K		R36			RK73GB2A154J	CHIP R 150K J 1/10W	
C34			CK73GB1H104K	CHIP C 0.10UF K		R37			RK73GB2A334J	CHIP R 330K J 1/10W	
C35			CK73GB1H153K	CHIP C 0.015UF K		R38			RK73GB2A223J	CHIP R 22K J 1/10W	
C36			CK73GB1H104K	CHIP C 0.10UF K		R40			RK73GB2A273J	CHIP R 27K J 1/10W	
C38			CC73GCH1H680J	CHIP C 68PF J		R41			RK73GB2A393J	CHIP R 39K J 1/10W	
C39,40			CK73GB1H104K	CHIP C 0.10UF K		R45			RK73GB2A221J	CHIP R 220 J 1/10W	
C41			CK73GB1A105K	CHIP C 1.0UF K		R46			RK73GB2A105J	CHIP R 1.0M J 1/10W	
C44			CK73GB1H104K	CHIP C 0.10UF K		R48,49			RK73GB2A105J	CHIP R 1.0M J 1/10W	
						R50			RK73GB2A560J	CHIP R 56 J 1/10W	

E : KDC-W4037Y E1 : KDC-W3537AY E2 : KDC-W3537GY E3 : KDC-W3037AY E4 : KDC-W3037GY E5 : KDC-W311AY E6 : KDC-W311GY E7 : KDC-W237AY E8 : KDC-W237GY Δ Indicates safety critical components.

PARTS LIST

CD PLAYER UNIT (X32-5970-00) IN CD MECHA

Ref. No.	A d d	N e w	Parts No.	Description	Desti- nation	Ref. No.	A d d	N e w	Parts No.	Description	Desti- nation
R51			RK73EB2E220J	CHIP R 22 J 1/4W		C101,102			CK73GB1H103K	CHIP C 0.010UF K	
R52			RK73EB2E100J	CHIP R 10 J 1/4W		C202			CC73GCH1H180J	CHIP C 18PF J	
R55			RK73GB2A103J	CHIP R 10K J 1/10W		C203			CC73GCH1H220J	CHIP C 22PF J	
R59			RK73GB2A4R7J	CHIP R 4.7 J 1/10W		C204			CK73GB1H104K	CHIP C 0.10UF K	
R60,61			RK73GB2A103J	CHIP R 10K J 1/10W		C205			CK73GB1H102K	CHIP C 1000PF K	
R82,83			RK73GB2A102J	CHIP R 1.0K J 1/10W		C301,302			CD04AB1HR47M	ELECTRO 0.47UF 50WV	
R216,217			RK73GB2A103J	CHIP R 10K J 1/10W		C306,307			CK73FB1E474K	CHIP C 0.47UF K	
R218			RK73GB2A102J	CHIP R 1.0K J 1/10W		C308			CD04AB0J470M	ELECTRO 47UF 6.3WV	
R219,220			RK73GB2A472J	CHIP R 4.7K J 1/10W		C309			CK73GB1H103K	CHIP C 0.010UF K	
R221,222			RK73GB2A101J	CHIP R 100 J 1/10W		C401			CD04AB1C470M	ELECTRO 47UF 16WV	
R223			RK73GB2A103J	CHIP R 10K J 1/10W		C403			CD04AB1H010M	ELECTRO 1.0UF 50WV	
R226-230			RK73GB2A101J	CHIP R 100 J 1/10W		C404			CK73GB1H103K	CHIP C 0.010UF K	EE1E2
R231			RK73GB2A473J	CHIP R 47K J 1/10W		C405			CK73GB1H104K	CHIP C 0.10UF K	EE1E2
R232			RK73GB2A104J	CHIP R 100K J 1/10W		C502			CK73GB1H103K	CHIP C 0.010UF K	
R233			RK73GB2A331J	CHIP R 330 J 1/10W		C504			CK73GB1H103K	CHIP C 0.010UF K	
R239			RK73GB2A472J	CHIP R 4.7K J 1/10W		C506			CK73GB1H103K	CHIP C 0.010UF K	
R240			RK73EB2E470J	CHIP R 47 J 1/4W		C508			CK73GB1H103K	CHIP C 0.010UF K	
R241			RK73GB2A104J	CHIP R 100K J 1/10W		C509,510			CK73GB1A474K	CHIP C 0.47UF K	
R243			RK73GB2A472J	CHIP R 4.7K J 1/10W		C511			CD04AB1V100M	ELECTRO 10UF 35WV	EE1E2
R244			RK73GB2A225J	CHIP R 2.2M J 1/10W		C511			CD04AB1V100M	ELECTRO 10UF 35WV	E3E4E5
R245			RK73GB2A000J	CHIP R 0.0 J 1/10W		C511			CD04AB1V100M	ELECTRO 10UF 35WV	E6
R246			RK73GB2A333J	CHIP R 33K J 1/10W		C512			CK73GB1H103K	CHIP C 0.010UF K	EE1E2
R247			RK73GB2A183J	CHIP R 18K J 1/10W		C512			CK73GB1H103K	CHIP C 0.010UF K	E3E4E5
R248			RK73GB2A472J	CHIP R 4.7K J 1/10W		C512			CK73GB1H103K	CHIP C 0.010UF K	E6
R251			RK73GB2A473J	CHIP R 47K J 1/10W		C513			CD04AB1V100M	ELECTRO 10UF 35WV	EE1E2
R252			RK73GB2A000J	CHIP R 0.0 J 1/10W		C513			CD04AB1V100M	ELECTRO 10UF 35WV	E3E4E5
S1,2			S68-0863-05	PUSH SWITCH		C513			CD04AB1V100M	ELECTRO 10UF 35WV	E6
S3			S68-0862-05	PUSH SWITCH		C514			CC73GCH1H331J	CHIP C 330PF J	EE1E2
D1			DA204U	DIODE		C514			CC73GCH1H331J	CHIP C 330PF J	E3E4E5
D2			DAP202U	DIODE		C514			CC73GCH1H331J	CHIP C 330PF J	E6
D3,4			DA204U	DIODE		C515,516			CC73GCH1H100D	CHIP C 10PF D	EE1E2
IC3			BA5824FP	ANALOGUE IC		C515,516			CC73GCH1H100D	CHIP C 10PF D	E3E4E5
IC4		*	TC94A70FG-007	MOS-IC		C517			CC73GCH1H561J	CHIP C 560PF J	E6
IC5		*	S-1132B15U5T1G	ANALOGUE IC		C517			CC73GCH1H561J	CHIP C 560PF J	EE1E2
IC6		*	S-1132B33U5T1G	ANALOGUE IC		C601,602			CK73FB1E474K	CHIP C 0.47UF K	EE1E2
IC7			TAR5S33-F	ANALOGUE IC		C603	*		CD04AC0J470M	ELECTRO 47UF 6.3WV	EE1E2
IC11		*	XC6206P152MR	ANALOGUE IC		C604			CK73GB1H103K	CHIP C 0.010UF K	EE1E2
Q1			2SB0970	TRANSISTOR		C701,702			CD04AB1V100M	ELECTRO 10UF 35WV	E
Q10-12			UM6K1N	DUAL FET		C703,704			CC73GCH1H681J	CHIP C 680PF J	E
Q13			DTC114YUA	DIGITAL TRANSISTOR		C801-804			C90-6735-05	NP-ELECT 0.22UF 50WV	
ELECTRIC UNIT (X34-467x-xx)									CD04AB1V100M	ELECTRO 10UF 35WV	
D302			B30-1567-05	LED (1608,RED)		C805			CD04AB1H010M	ELECTRO 1.0UF 50WV	
C1		*	CD04AZ1C332M2	ELECTRO 3300UF 16WV		C807			CD04AB1H010M	ELECTRO 1.0UF 50WV	
C2			CD04AB1C220M	ELECTRO 22UF 16WV		C808			C90-6802-05	ELECTRO 1UF 50WV	
C3			CK73GB1H104K	CHIP C 0.10UF K		C809			CD04AB1H010M	ELECTRO 1.0UF 50WV	
C5,6			CD04AT1E101M	ELECTRO 100UF 25WV		C901,902			CD04AB1C101M	ELECTRO 100UF 16WV	
C7			CD04AB0J101M	ELECTRO 100UF 6.3WV		C990			CK73GB1H223K	CHIP C 0.022UF K	
C9			CK73GB1H104K	CHIP C 0.10UF K		CN2			E41-2581-05	FLAT CABLE CONNECTOR	
C11			CK73FB1A225K	CHIP C 2.2UF K		J1			E58-0991-05	RECTANGULAR RECEPTACLE	
C12			CK73GB1H104K	CHIP C 0.10UF K		J2	*		E04-0334-05	RF COAXIAL CABLE RECEPTACLE	
C14			CK73GB1H104K	CHIP C 0.10UF K		J3	*		E58-1060-05	RECTANGULAR RECEPTACLE	
C15			CD04AB1C220M	ELECTRO 22UF 16WV		J4			E56-0855-05	CYLINDRICAL RECEPTACLE	EE1E2
						J5	*		E63-0941-05	PIN JACK	E

PARTS LIST

ELECTRIC UNIT (X34-467x-xx)

Ref. No.	Add	New	Parts No.	Description	Destination	Ref. No.	Add	New	Parts No.	Description	Destination
L1			L33-2319-05	CHOKE COIL ASSY		R227			RK73GB2A223J	CHIP R 22K J 1/10W	E5E6E7
L401			L41-4795-33	SMALL FIXED INDUCTOR (4.7UH)		R227			RK73GB2A223J	CHIP R 22K J 1/10W	E8
X1		*	L78-1218-05	RESONATOR (10.000MHZ)		R228			RK73GB2A473J	CHIP R 47K J 1/10W	
X2			L77-2920-05	CRYSTAL RESONATOR (32.768KHZ)		R229			RK73GB2A104J	CHIP R 100K J 1/10W	EE1E2
X3			L77-2002-05	CRYSTAL RESONATOR (4.332MHZ)	EE1E2	R301			RK73GB2A222J	CHIP R 2.2K J 1/10W	
X3			L77-2002-05	CRYSTAL RESONATOR (4.332MHZ)	E3E4E5	R302			RD14BB2C101J	RD 100 J 1/6W	
X3			L77-2002-05	CRYSTAL RESONATOR (4.332MHZ)	E6	R303			RK73GB2A102J	CHIP R 1.0K J 1/10W	
F	2D		N80-3010-48	PAN HEAD TAPTITE SCREW		R304			RD14BB2C102J	RD 1.0K J 1/6W	
G	2D		N83-3005-48	PAN HEAD TAPTITE SCREW		R305			RK73GB2A102J	CHIP R 1.0K J 1/10W	
H	2D		N83-3020-48	PAN HEAD TAPTITE SCREW		R306			RK73GB2A472J	CHIP R 4.7K J 1/10W	
J	3D		N86-2606-48	BINDING HEAD TAPTITE SCREW		R307			RK73GB2A222J	CHIP R 2.2K J 1/10W	
R1			RD14BB2C102J	RD 1.0K J 1/6W		R310-313			RK73GB2A102J	CHIP R 1.0K J 1/10W	
R2-5			RD14BB2C103J	RD 10K J 1/6W		R314			RK73GB2A104J	CHIP R 100K J 1/10W	
R11			RD14DB2H100J	SMALL-RD 10 J 1/2W		R315			RK73GB2A472J	CHIP R 4.7K J 1/10W	
R12-14			RK73PB2H100J	CHIP R 10 J 1/2W		R316,317			RK73GB2A222J	CHIP R 2.2K J 1/10W	
R15			RD14DB2H100J	SMALL-RD 10 J 1/2W		R318			RK73GB2A472J	CHIP R 4.7K J 1/10W	
R16			RK73FB2B681J	CHIP R 680 J 1/8W		R319			RK73GB2A222J	CHIP R 2.2K J 1/10W	
R17			RK73GB2A272J	CHIP R 2.7K J 1/10W		R320			RK73GB2A472J	CHIP R 4.7K J 1/10W	
R101,102			RD14BB2C472J	RD 4.7K J 1/6W		R323			RD14BB2C241J	RD 240 J 1/6W	
R103			RD14BB2C103J	RD 10K J 1/6W		R330			RD14BB2C222J	RD 2.2K J 1/6W	
R104			RK73GB2A473J	CHIP R 47K J 1/10W		R331			RK73GB2A473J	CHIP R 47K J 1/10W	
R105			RK73GB2A104J	CHIP R 100K J 1/10W		R332			RD14BB2C222J	RD 2.2K J 1/6W	
R106			RD14DB2H332J	SMALL-RD 3.3K J 1/2W		R333,334			RD14BB2C102J	RD 1.0K J 1/6W	EE1E2
R107			RD14BB2C333J	RD 33K J 1/6W		R334			RD14BB2C102J	RD 1.0K J 1/6W	E3E4E5
R108			RK73GB2A103J	CHIP R 10K J 1/10W		R334			RD14BB2C102J	RD 1.0K J 1/6W	E6E7E8
R109			RD14BB2C223J	RD 22K J 1/6W		R335			RK73GB2A473J	CHIP R 47K J 1/10W	
R110			RK73FB2B683J	CHIP R 68K J 1/8W		R336-339			RD14BB2C222J	RD 2.2K J 1/6W	
R111			RK73GB2A393J	CHIP R 39K J 1/10W		R340			RK73GB2A225J	CHIP R 2.2M J 1/10W	
R112			RD14BB2C203J	RD 20K J 1/6W		R341			RD14BB2C222J	RD 2.2K J 1/6W	
R113			RK73GB2A104J	CHIP R 100K J 1/10W		R342			RK73GB2A473J	CHIP R 47K J 1/10W	
R114,115			RK73GB2A103J	CHIP R 10K J 1/10W		R343			RD14BB2C102J	RD 1.0K J 1/6W	
R116,117			RD14BB2C103J	RD 10K J 1/6W		R344,345			RD14BB2C4R7J	RD 4.7 J 1/6W	
R201			RK73GB2A473J	CHIP R 47K J 1/10W	EE1E2	R346			RD14BB2C2R2J	RD 2.2 J 1/6W	
R202			RK73GB2A104J	CHIP R 100K J 1/10W	EE1E2	R347			RK73GB2A102J	CHIP R 1.0K J 1/10W	
R203,204			RK73GB2A103J	CHIP R 10K J 1/10W		R402,403			RD14BB2C471J	RD 470 J 1/6W	
R205-207			RK73GB2A473J	CHIP R 47K J 1/10W		R404			RD14BB2C102J	RD 1.0K J 1/6W	EE1E2
R208			RD14BB2C473J	RD 47K J 1/6W		R405			RK73GB2A473J	CHIP R 47K J 1/10W	EE1E2
R209,210			RD14BB2C471J	RD 470 J 1/6W		R406			RK73GB2A223J	CHIP R 22K J 1/10W	E
R211,212			RK73GB2A473J	CHIP R 47K J 1/10W		R407			RD14BB2C103J	RD 10K J 1/6W	E
R214			RK73GB2A223J	CHIP R 22K J 1/10W	EE1E2	R408			RK73GB2A152J	CHIP R 1.5K J 1/10W	E
R214			RK73GB2A223J	CHIP R 22K J 1/10W	E3E4E5	R409			RK73GB2A392J	CHIP R 3.9K J 1/10W	E
R214			RK73GB2A223J	CHIP R 22K J 1/10W	E6	R491,492			RK73GB2A100J	CHIP R 10 J 1/10W	E3E4E5
R218			RK73GB2A223J	CHIP R 22K J 1/10W		R491,492			RK73GB2A100J	CHIP R 10 J 1/10W	E6E7E8
R219,220			RD14BB2C104J	RD 100K J 1/6W	EE1E2	R493			RD14BB2C100J	RD 10 J 1/6W	E3E4E5
R221			RK73GB2A222J	CHIP R 2.2K J 1/10W	EE1E2	R493			RD14BB2C100J	RD 10 J 1/6W	E6E7E8
R221			RK73GB2A222J	CHIP R 2.2K J 1/10W	E3E4E5	R501			RK73GB2A471J	CHIP R 470 J 1/10W	
R221			RK73GB2A222J	CHIP R 2.2K J 1/10W	E6	R502			RK73GB2A472J	CHIP R 4.7K J 1/10W	
R223			RK73GB2A222J	CHIP R 2.2K J 1/10W		R503			RK73GB2A471J	CHIP R 470 J 1/10W	
R225			RK73GB2A473J	CHIP R 47K J 1/10W	E1E2	R504			RK73GB2A472J	CHIP R 4.7K J 1/10W	
R225,226			RK73GB2A473J	CHIP R 47K J 1/10W	E7E8	R506,507			RK73GB2A222J	CHIP R 2.2K J 1/10W	EE1E2
R226			RK73GB2A473J	CHIP R 47K J 1/10W	EE3E4	R506,507			RK73GB2A222J	CHIP R 2.2K J 1/10W	E3E4E5
R226			RK73GB2A473J	CHIP R 47K J 1/10W	E5E6	R506,507			RK73GB2A222J	CHIP R 2.2K J 1/10W	E6
R226,227			RK73GB2A223J	CHIP R 22K J 1/10W	E1E2	R508			RD14BB2C222J	RD 2.2K J 1/6W	EE1E2
R227			RK73GB2A223J	CHIP R 22K J 1/10W	EE3E4	R508			RD14BB2C222J	RD 2.2K J 1/6W	E3E4E5
						R508			RD14BB2C222J	RD 2.2K J 1/6W	E6

E : KDC-W4037Y E1 : KDC-W3537AY E2 : KDC-W3537GY E3 : KDC-W3037AY E4 : KDC-W3037GY E5 : KDC-W311AY E6 : KDC-W311GY E7 : KDC-W237AY E8 : KDC-W237GY Δ Indicates safety critical components.

PARTS LIST

ELECTRIC UNIT (X34-467x-xx)

Ref. No.	A d	N e w	Parts No.	Description	Desti- nation
R509			RK73GB2A512J	CHIP R 5.1K J 1/10W	EE1E2
R509			RK73GB2A512J	CHIP R 5.1K J 1/10W	E3E4E5
R509			RK73GB2A512J	CHIP R 5.1K J 1/10W	E6
R598			RK73GB2A223J	CHIP R 22K J 1/10W	
R599			RK73GB2A102J	CHIP R 1.0K J 1/10W	
R601,602			RD14BB2C100J	RD 10 J 1/6W	EE1E2
R603			RD14BB2C4R7J	RD 4.7 J 1/6W	EE1E2
R604			RK73GB2A102J	CHIP R 1.0K J 1/10W	EE1E2
R605			RD14BB2C101J	RD 100 J 1/6W	EE1E2
R606,607			RD14BB2C102J	RD 1.0K J 1/6W	EE1E2
R608,609			RD14BB2C101J	RD 100 J 1/6W	EE1E2
R610			RD14BB2C472J	RD 4.7K J 1/6W	EE1E2
R611			RD14BB2C101J	RD 100 J 1/6W	EE1E2
R612			RD14BB2C472J	RD 4.7K J 1/6W	EE1E2
R701,702			RK73GB2A331J	CHIP R 330 J 1/10W	E
R703,704			RD14BB2C223J	RD 22K J 1/6W	E
R705,706			RD14BB2C181J	RD 180 J 1/6W	E
R793			RK73EB2E000J	CHIP R 0.0 J 1/4W	E
R802			RK73GB2A154J	CHIP R 150K J 1/10W	
R804			RK73GB2A331J	CHIP R 330 J 1/10W	
R805			RK73GB2A154J	CHIP R 150K J 1/10W	
R806			RK73GB2A472J	CHIP R 4.7K J 1/10W	
R807			RK73GB2A432J	CHIP R 4.3K J 1/10W	
R808			RK73GB2A100J	CHIP R 10 J 1/10W	
R892			RK73GB2A000J	CHIP R 0.0 J 1/10W	
R901,902			RK73GB2A334J	CHIP R 330K J 1/10W	
R903			RK73GB2A153J	CHIP R 15K J 1/10W	
R904			RK73GB2A223J	CHIP R 22K J 1/10W	
R905,906			RK73GB2A104J	CHIP R 100K J 1/10W	
R907-914			RD14BB2C104J	RD 100K J 1/6W	
R915			RK73GB2A104J	CHIP R 100K J 1/10W	
R951			RK73EB2E000J	CHIP R 0.0 J 1/4W	
R952			RK73GB2A000J	CHIP R 0.0 J 1/10W	
R954			RK73GB2A000J	CHIP R 0.0 J 1/10W	
R955			RK73EB2E000J	CHIP R 0.0 J 1/4W	
R958			RK73GB2A000J	CHIP R 0.0 J 1/10W	E
R962,963			RK73GB2A000J	CHIP R 0.0 J 1/10W	
R964,965			RK73EB2E000J	CHIP R 0.0 J 1/4W	
R967			RK73GB2A471J	CHIP R 470 J 1/10W	
R968			RK73GB2A000J	CHIP R 0.0 J 1/10W	E1E2E3
R968			RK73GB2A000J	CHIP R 0.0 J 1/10W	E4E5E6
R968			RK73GB2A000J	CHIP R 0.0 J 1/10W	E7E8
R968-971			RK73GB2A000J	CHIP R 0.0 J 1/10W	E
R971			RK73GB2A000J	CHIP R 0.0 J 1/10W	E1E2E3
R971			RK73GB2A000J	CHIP R 0.0 J 1/10W	E4E5E6
R971			RK73GB2A000J	CHIP R 0.0 J 1/10W	E7E8
R972			RK73EB2E000J	CHIP R 0.0 J 1/4W	EE1E2
R973			RK73GB2A000J	CHIP R 0.0 J 1/10W	
D1			S2V60*A	DIODE	
D2			MTZJ8.2(B)	ZENER DIODE	
D3			D1F60-5063	DIODE	
D4			1SS133	DIODE	
D7			MTZJ12(B)	ZENER DIODE	
D101,102			D1F60-5063	DIODE	

Ref. No.	A d	N e w	Parts No.	Description	Desti- nation
D103			AM01ZNF	DIODE	
D104			D1F60-5063	DIODE	
D105			MTZJ4.7(B)	ZENER DIODE	
D106-108			MTZJ6.8(B)	ZENER DIODE	
D109			1SS133	DIODE	
D110			MC2848	DIODE	
D301			DA204U	DIODE	
D304,305			UDZS6.8B	ZENER DIODE	
D306			MTZJ6.8(B)	ZENER DIODE	
D401			1SS133	DIODE	
D404			1SS133	DIODE	E
D601-606			MTZJ6.8(B)	ZENER DIODE	EE1E2
D801			MC2848	DIODE	
D803			1SS133	DIODE	
D901			MTZJ4.7(B)	ZENER DIODE	
IC1		*	30622MEPB25FP	MICROCONTROLLER IC	E3E4E5
IC1		*	30622MEPB25FP	MICROCONTROLLER IC	E6E7E8
IC1		*	30622MGPB23FP	MICROCONTROLLER IC	EE1E2
IC2		*	E-TDA7419	ANALOGUE IC	E
IC3		*	E-TDA7418	ANALOGUE IC	E1E2E3
IC3		*	E-TDA7418	ANALOGUE IC	E4E5E6
IC3		*	E-TDA7418	ANALOGUE IC	E7E8
IC4		*	BD4913-V4	ANALOGUE IC	
IC6			KKZ09Z	ANALOGUE IC	EE1E2
IC6			KKZ09Z	ANALOGUE IC	E3E4E5
IC6			KKZ09Z	ANALOGUE IC	E6
IC6			TB2904HQ	ANALOGUE IC	E7E8
IC7		*	LC72725KV	ANALOGUE IC	EE1E2
IC7		*	LC72725KV	ANALOGUE IC	E3E4E5
IC7		*	LC72725KV	ANALOGUE IC	E6
IC8			S-80836CNNB-J	MOS-IC	
IC9			HEF4053BT	MOS-IC	EE1E2
Q1			UMC2N	TRANSISTOR	
Q2			2SB1565	TRANSISTOR	
Q3			2SC4081	TRANSISTOR	
Q7			UMC2N	TRANSISTOR	
Q8			2SB1565	TRANSISTOR	
Q9			2SC4081	TRANSISTOR	
Q101-103			2SC4081	TRANSISTOR	
Q104,105			RT1N441M	TRANSISTOR	
Q301			RT1P144M	TRANSISTOR	
Q302			RT1N144M	TRANSISTOR	
Q401			RT1N441M	TRANSISTOR	EE1E2
Q402			2SC4081	TRANSISTOR	E
Q701,702			RT1N430M	TRANSISTOR	E
Q705			RT1P241M	TRANSISTOR	E
Q901			2SC4081	TRANSISTOR	
Q902,903			2SA1576A	TRANSISTOR	
TH1			PRF18BE471QS2	POSITIVE RESISTOR	
A1	2D	*	X86-4032-70	FRONT-END UNIT	
MECHANISM ASSY (X92-5880-00) DXM-6E00W					
1	2B		A10-5328-11	CHASSIS	
2	1B		A10-5329-01	CHASSIS	

PARTS LIST

MECHANISM ASSY (X92-5880-00) DXM-6E00W

Ref. No.	Add	New	Parts No.	Description	Destination	Ref. No.	Add	New	Parts No.	Description	Destination
5	2B		D10-4910-13	ARM ASSY		DPU1	2B		X93-2130-01	OPTICAL PICKUP ASSY (LF)	
8	2A		D10-4911-03	LEVER ASSY							
10	2A		D10-4906-33	ARM							
11	2A		D10-4907-33	ARM							
12	3A		D10-4908-03	ARM							
13	3A		D10-4909-03	ARM							
14	3B		D10-4915-03	ARM							
15	2A		D10-4916-23	SLIDER							
16	3B		D10-4914-12	SLIDER							
17	2B		D10-4588-13	SLIDER							
18	2B		D10-4917-04	ARM							
19	2B		D10-4596-24	ARM							
22	2A		D13-2151-04	GEAR							
23	2B		D13-2152-04	GEAR							
24	3B		D13-2153-04	GEAR							
25	3B		D13-2154-04	GEAR							
26	3B		D13-2155-04	WORM							
27	2B		D13-2156-14	GEAR							
28	3B		D13-2157-04	GEAR							
29	2B		D13-2158-04	GEAR							
30	2B		D13-2168-04	GEAR							
31	3B		D13-2171-04	GEAR							
32	1B		D13-2400-13	RACK (GEAR)							
33	2A		D14-0759-04	ROLLER							
35	2B		D21-2382-04	SHAFT							
36	1A		D23-0954-04	RETAINER							
37	1B		D39-0246-05	DAMPER							
38	2B		G01-3072-04	EXTENSION SPRING							
39	2A		G01-3073-04	TORSION COIL SPRING							
40	2A		G01-3074-04	EXTENSION SPRING							
41	1B		G01-4615-04	EXTENSION SPRING							
42	2A		G01-3076-04	EXTENSION SPRING							
43	1B		G01-3077-14	EXTENSION SPRING							
44	2B		G02-1399-04	FLAT SPRING							
45	2B		G02-1547-04	FLAT SPRING							
51	1A		J22-0473-21	MOUNTING HARDWARE							
52	3B		J22-0474-12	MOUNTING HARDWARE							
53	1B		J22-0519-03	MOUNTING HARDWARE							
55	1A		J90-1138-31	GUIDE							
56	1B		J90-1023-03	GUIDE							
DFPC1	3A		J86-0027-05	FPC (LEAD FREE)							
A	2B		N09-4460-15	TAPTITE SCREW (PT2X8)							
B	1B		N09-6317-05	TAPTITE SCREW (1.6X6.0)							
C	2B		N09-6004-15	MACHINE SCREW (M1.7X2.5)							
E	2B		N09-6007-15	MACHINE SCREW (M2X2)							
F	1A		N09-6051-15	TAPTITE SCREW (PT2X5)							
G	2A		N19-2163-04	FLAT WASHER (1.6X6X0.25)							
H	1B		N39-2020-48	PAN HEAD MACHINE SCREW (M2X2)							
J	1B		N09-6108-15	TAPTITE SCREW (M2X3.5)							
K	3B		N09-6155-15	SEMS (TAPTITE SCREW) (PT2X6)							
DM1	3B		T42-1066-14	DC MOTOR (SPINDLE)							
DM2	2B		T42-1067-14	DC MOTOR (LOADING/SLED)							

E : KDC-W4037Y E1 : KDC-W3537AY E2 : KDC-W3537GY E3 : KDC-W3037AY E4 : KDC-W3037GY E5 : KDC-W311AY E6 : KDC-W311GY E7 : KDC-W237AY E8 : KDC-W237GY △ Indicates safety critical components.