

Service schematics

Nokia Lumia 520

RM-914 / RM-915

12.03.2013

v1.0



IMPORTANT

This document is intended for use by authorized Nokia service centers only. Please use the document together with other documents such as the Service Manual and Service Bulletins.

Version information

While every effort has been made to ensure that the document is accurate, some errors may exist. Please always check for the latest published version for this document.

If you find any errors in the document please send email to: service.manuals@nokia.com

1.0 First approved version.

Contents

- 1 Front page
- 2 PM8038, Power, UI keys, Vibra, IHF speaker, Bluetooth/WLAN
- 3 PM8038, MSM8227, Memory, Display, Touch, SIM
- 4 MSM8227, Audio, Camera, Sensors, Top PWB flex board
- 5 RF Transceiver (RM-914), GPS
- 6 RF Transceiver (RM-915), GPS
- 7 Component finder Top (RM-914)
- 8 Component finder Top (RM-915)
- 9 Component finder Bottom (RM-914/RM-915), Top PWB flex board

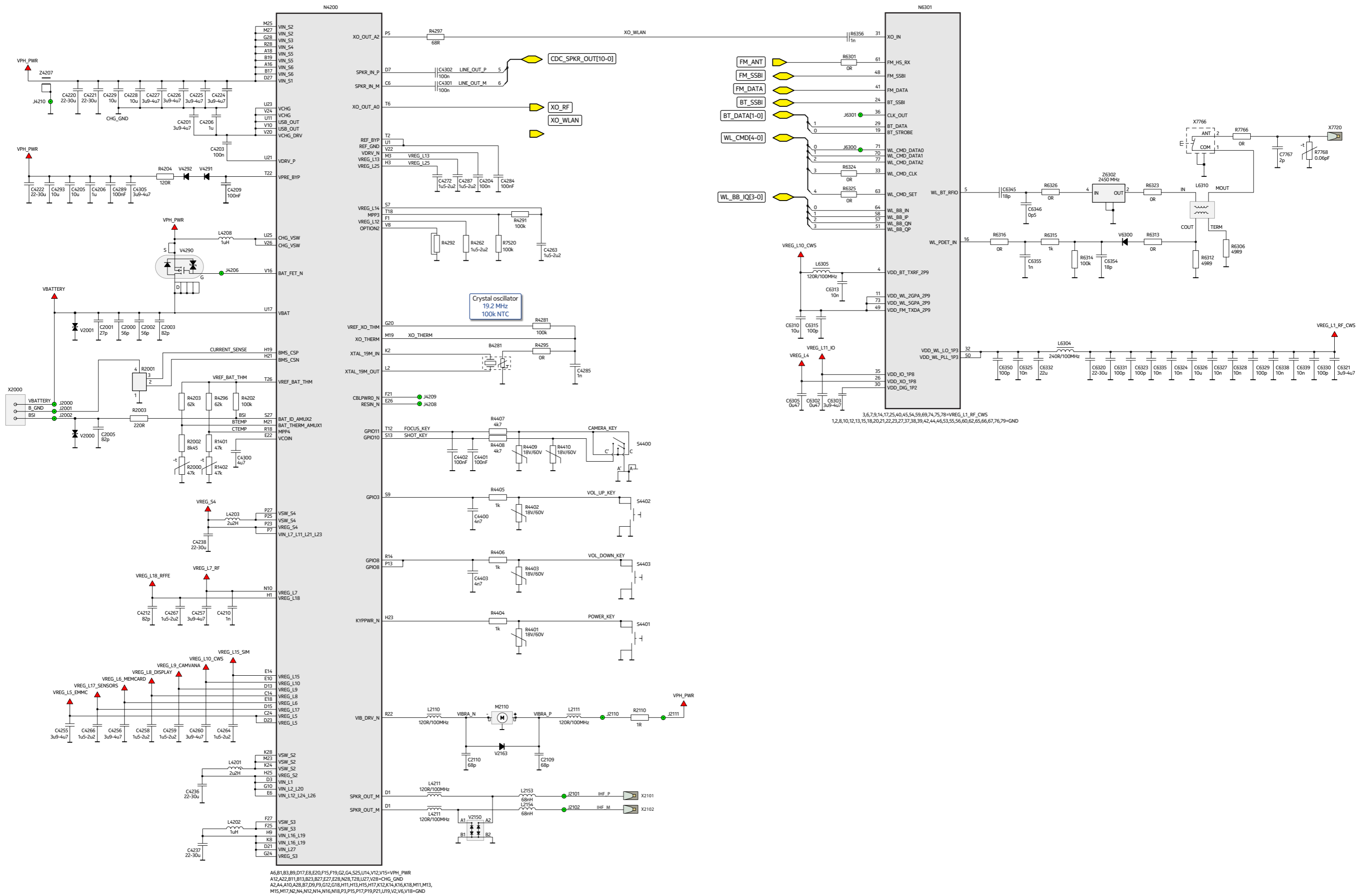

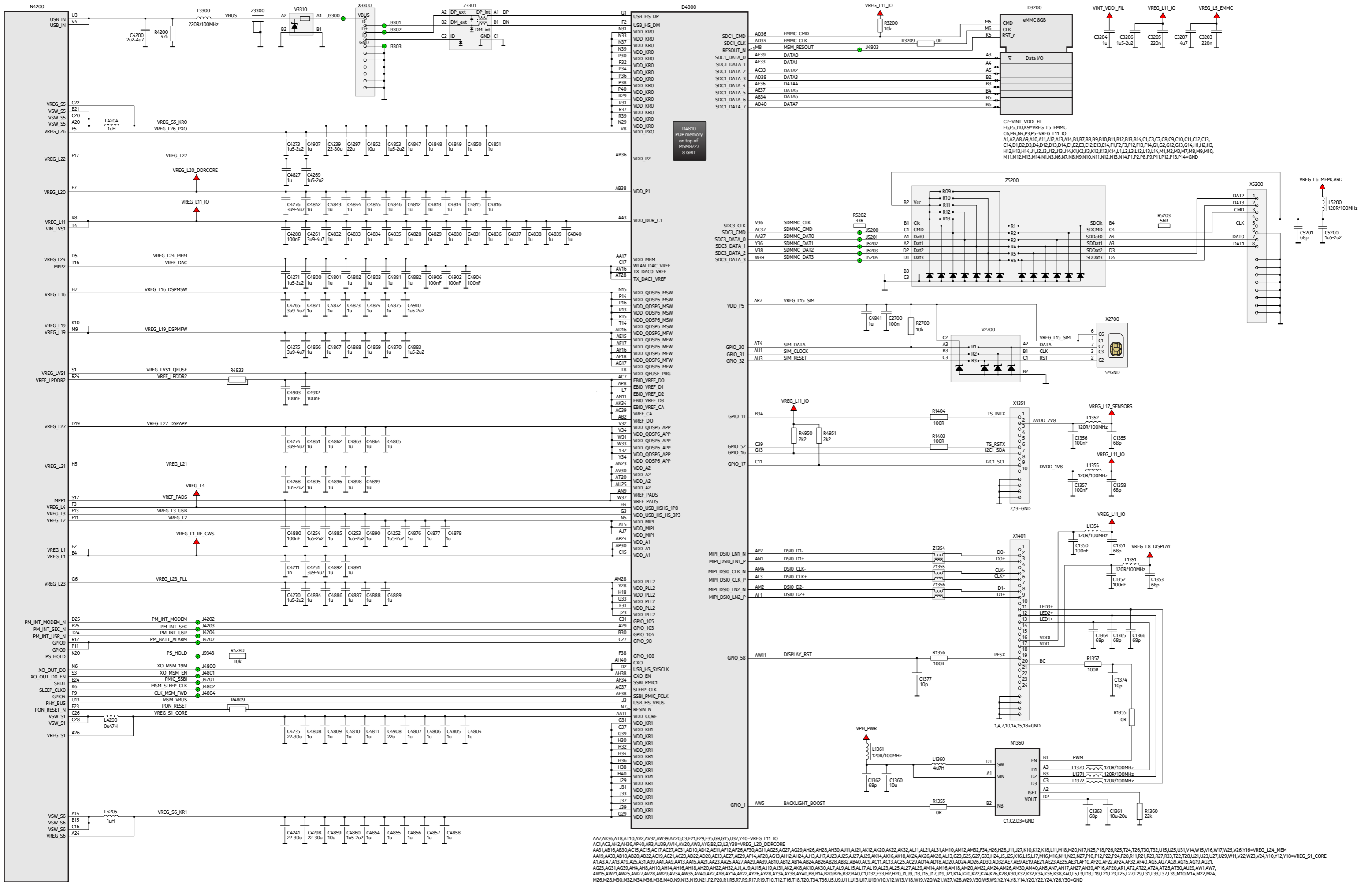

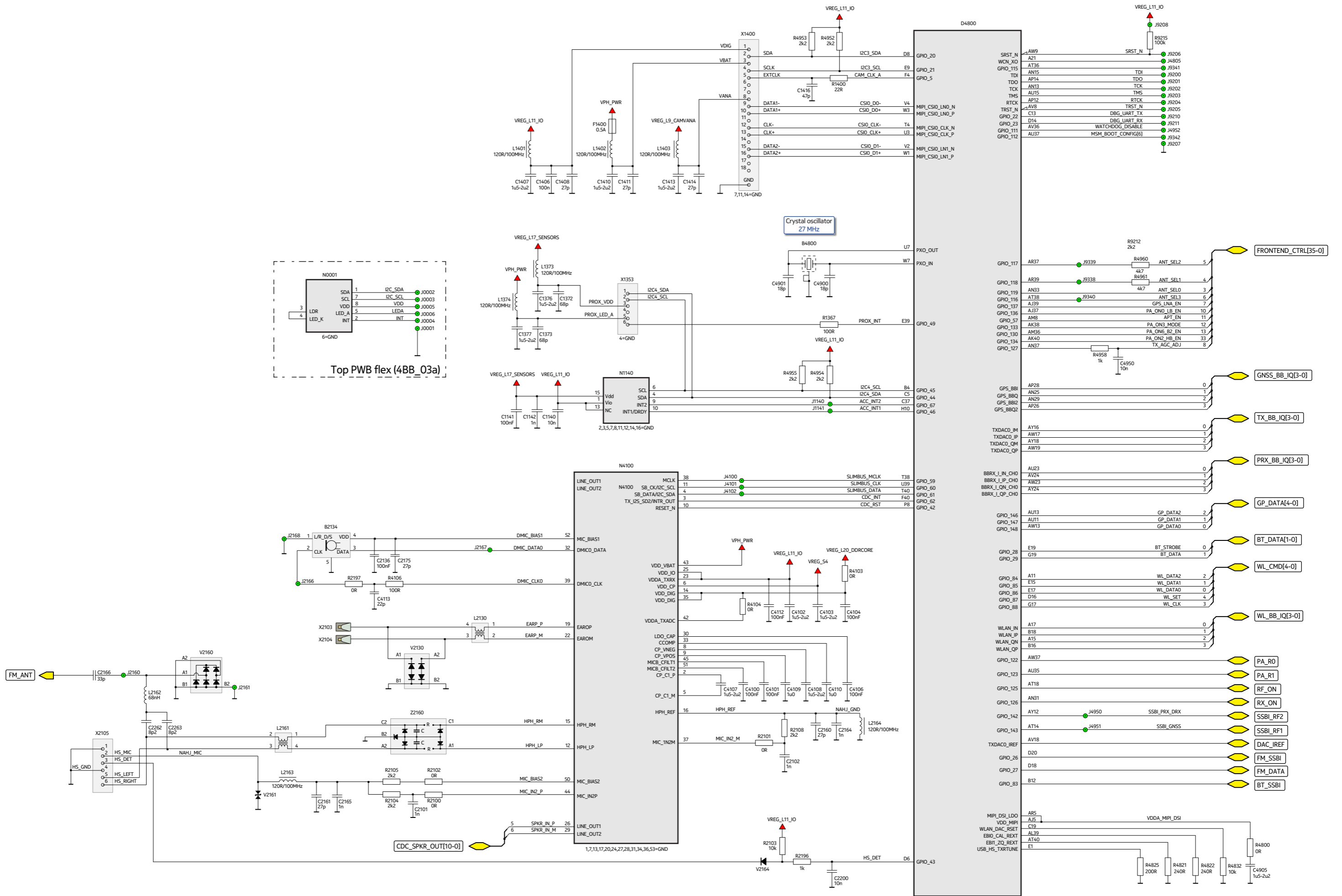

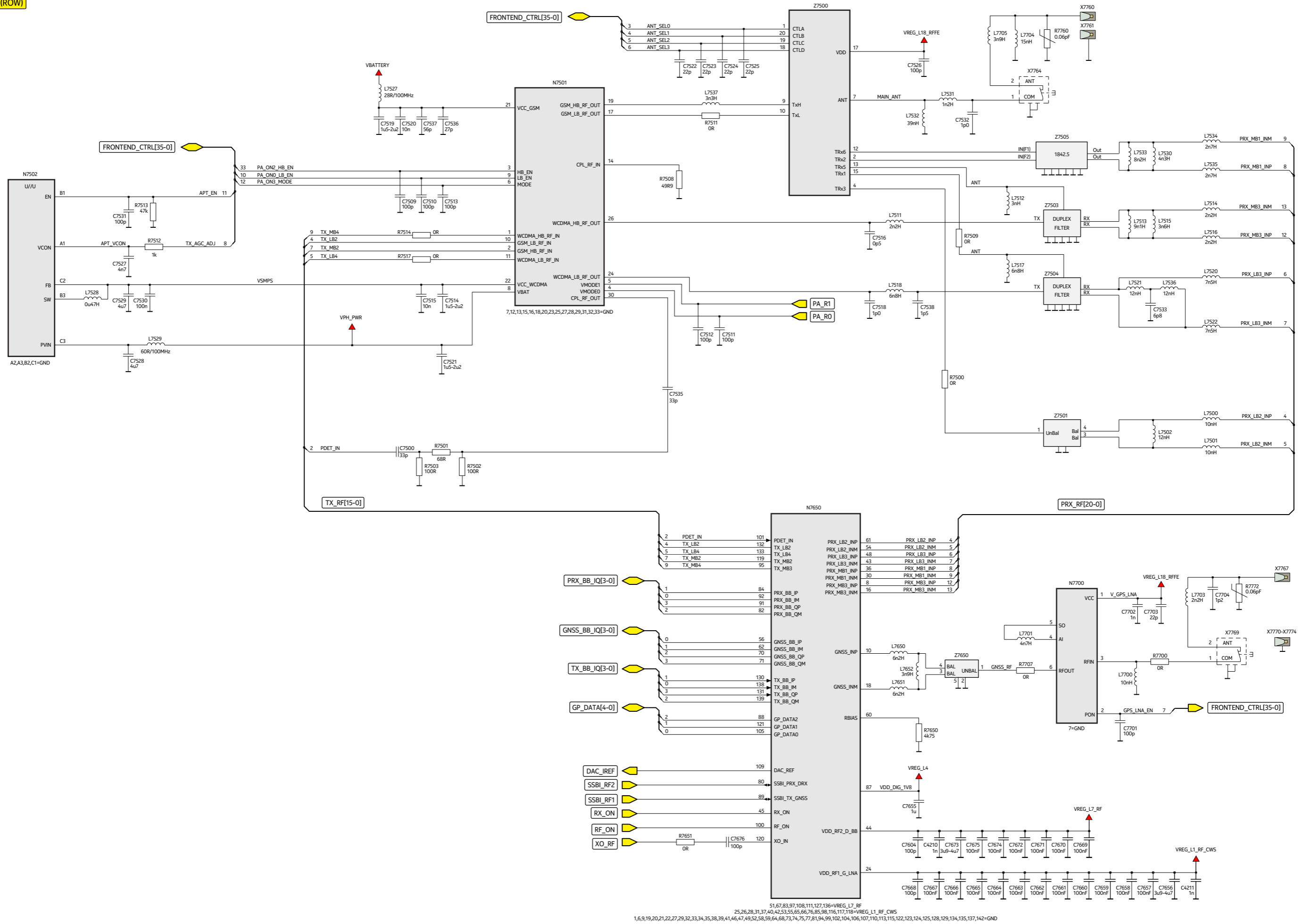

51,67,83,97,108,111,127,136=VREG_L7_RF
 25,26,28,31,37,40,42,53,55,65,66,76,85,98,116,117,118=VREG_L1_RF_CWS
 1,6,9,19,20,21,22,27,29,32,33,34,35,38,39,41,46,47,49,52,58,59,64,68,73,74,75,77,81,94,99,102,104,106,107,110,113,115,122,123,124,125,128,129,134,135,137,142=GND

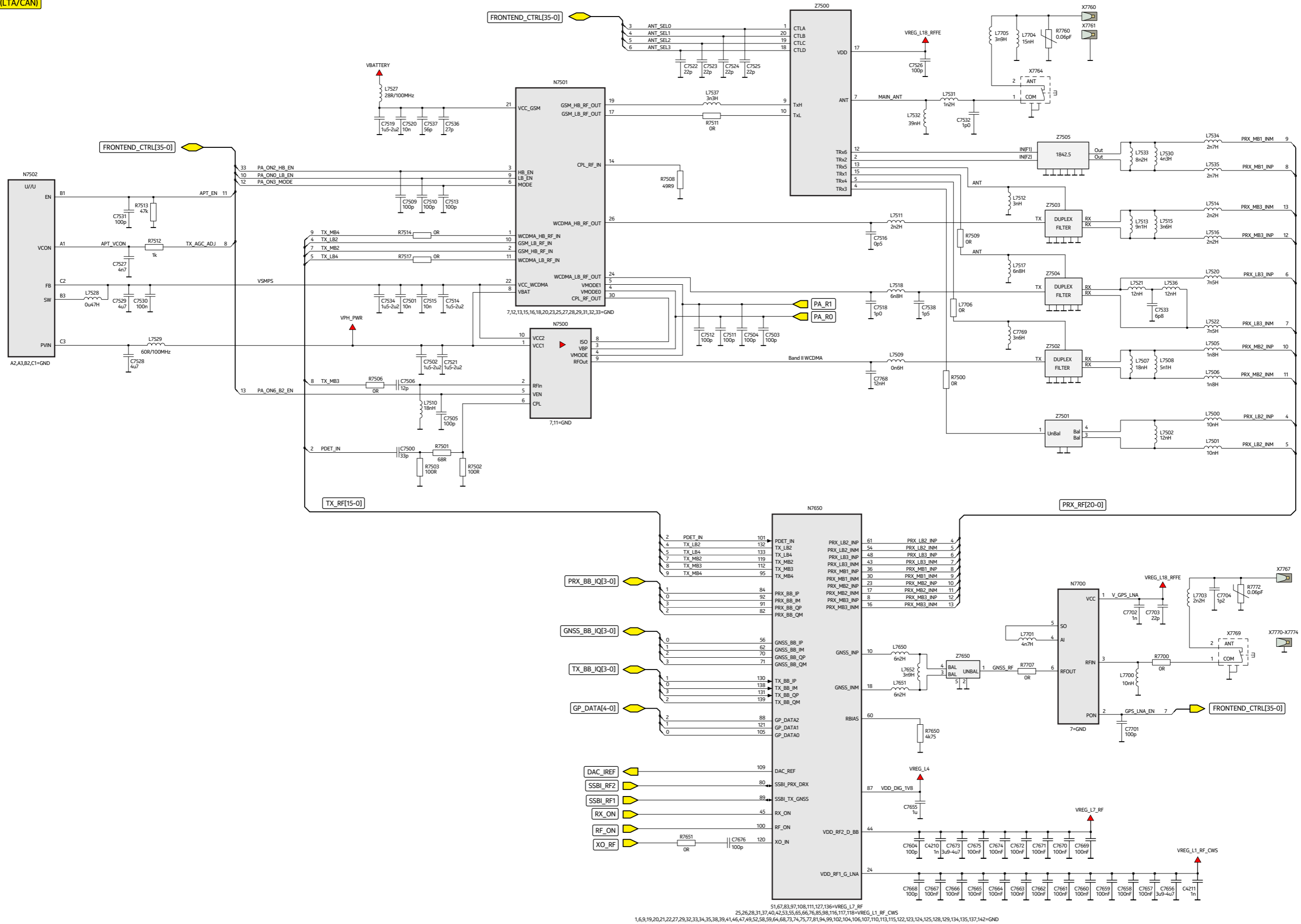

51,67,83,97,108,111,127,136=VREG_L7_RF
 25,26,28,31,37,40,42,53,55,65,66,76,85,98,116,117,118=VREG_L1_RF_CWS
 1,6,9,19,20,21,22,27,29,32,33,34,35,38,39,41,46,47,49,52,58,59,64,68,73,74,75,77,81,94,99,102,104,106,107,110,113,115,122,123,124,125,128,129,134,135,137,142=GND

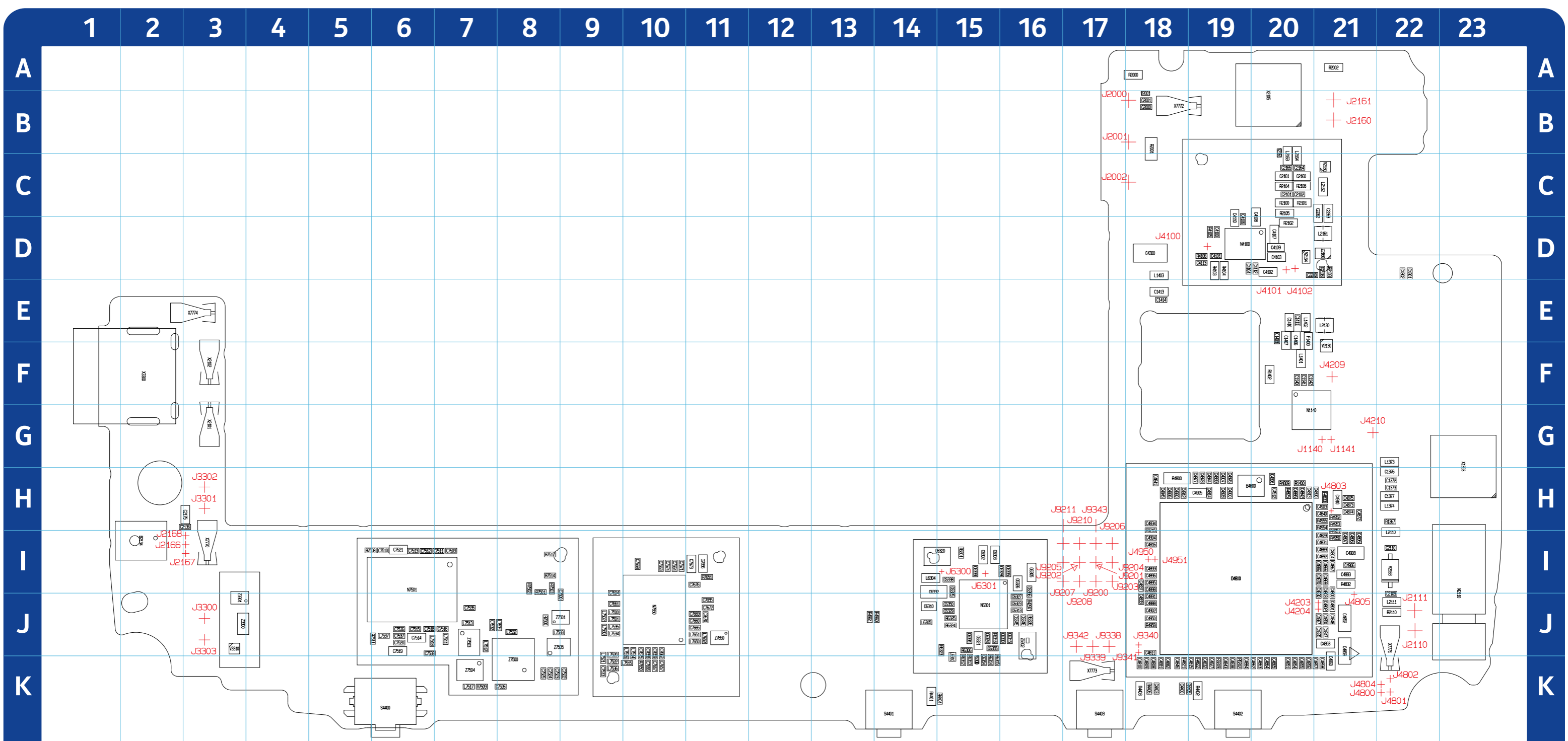

	1	2	3	4	5	6	7	8	9	10	11	12	13	14	15	16	17	18	19	20	21	22	23																								
B	C2000	B18	C4103	D20	C4804	I21	C4832	K19	C4851	K20	C4872	H21	C4891	J18	C6302	I15	C6335	I16	C7518	J6	C7657	K10	C7675	J10	L2163	C20	L7522	K9	N7501	I6	R3209	K19	R4833	H21	R6323	J15	S4401	K14	X7770	I3	J1141	G21	J4203	J21	J9204	I17	
B2134	I2	C2001	B18	C4104	D19	C4805	I21	C4833	J18	C4852	J21	C4873	H21	C4892	I21	C6303	I15	C6338	I15	C7519	J6	C7658	J10	C7676	I11	L2164	C20	L7530	J9	N7650	J10	R4103	D19	R4950	I21	R6324	J15	S4402	K19	X7771	J22	J2000	B18	J4204	J21	J9205	I17
B4800	H20	C2101	C20	C4106	D19	C4806	I21	C4834	H18	C4853	J21	C4874	H21	C4895	I18	C6305	I16	C6339	I15	C7520	J6	C7659	J10	D	L6304	I14	L7531	J8	R	R4104	D19	R4951	I21	R6325	J15	S4403	K17	X7772	B18	J2001	B18	J4209	F21	J9206	I17		
C	C2102	C20	C4107	D20	C4807	I21	C4835	J21	C4854	K20	C4875	H21	C4896	I18	C6310	J14	C6345	J16	C7521	I6	C7660	J11	D4800	I19	L6305	J14	L7532	J8	R1367	H22	R4105	D19	R4952	H21	R6326	J16	V	X7773	K17	J2002	C18	J4210	G21	J9207	I17		
C1140	F20	C2109	J22	C4108	D20	C4808	K18	C4836	H18	C4855	K20	C4876	H19	C4898	I18	C6313	J16	C6346	J16	C7522	K9	C7661	J9	D4810	I19	L6310	K15	L7533	J8	R1400	H20	R4106	D19	R4953	H21	R7500	J8	V2001	B18	X7774	E3	J2110	J22	J4800	K22	J9208	I17
C1141	F20	C2110	I22	C4109	D20	C4809	K18	C4837	I18	C4856	K20	C4877	H19	C4899	I18	C6315	J16	C6350	J15	C7523	K8	C7662	J10	F	L7500	J9	L7534	J9	R1402	F20	R4297	J16	R4954	H21	R7501	I8	V2130	F21	Z	J2111	J22	J4801	K22	J9210	I17		
C1142	F20	C2136	H3	C4110	D19	C4810	K18	C4838	K19	C4857	K21	C4878	H19	C4900	H19	C6320	I15	C6354	K15	C7524	K8	C7663	I10	F1400	E20	L7501	J9	L7535	J9	R2000	A18	R4401	K14	R4955	H21	R7502	I8	V2160	C21	Z2160	D21	J2160	B21	J4802	K22	J9211	I17
C1372	H22	C2160	C20	C4112	D20	C4811	J18	C4839	H19	C4858	K21	C4880	H18	C4901	H20	C6321	J15	C6355	J15	C7525	K8	C7664	I10	L	L7502	J9	L7536	K9	R2001	B18	R4402	K19	R4958	J18	R7503	I8	V2161	B20	Z3300	J3	J2161	B21	J4803	H21	J9338	J17	
C1373	H22	C2161	C20	C4113	D19	C4812	H18	C4840	H21	C4859	J21	C4881	K18	C4902	J18	C6323	J16	C6356	I16	C7526	K8	C7665	J11	L1373	G22	L7511	J7	L7537	J6	R2002	A21	R4403	K18	R4960	J14	R7508	I5	V2163	I22	Z3301	J3	J2166	I3	J4804	K22	J9339	J17
C1376	H22	C2164	C20	C4300	D18	C4813	H20	C4841	H18	C4860	K21	C4882	K18	C4903	H21	C6324	J15	C7500	J9	C7532	J7	C7666	K10	L1374	H22	L7512	J7	L7650	J11	R2100	C20	R4404	K15	R4961	J13	R7509	K7	V2164	D20	Z6302	J16	J2167	I3	J4805	J21	J9340	J18
C1377	H22	C2165	C20	C4301	D22	C4814	H19	C4842	H20	C4862	K20	C4883	I21	C4904	I18	C6325	I15	C7509	I7	C7533	K9	C7667	K10	L1401	F20	L7513	J7	L7651	J11	R2101	C20	R4405	K19	R5202	K19	R7511	J6	V3310	J3	Z7500	K8	J2168	I3	J4950	I18	J9341	J18
C1406	E20	C2175	H3	C4302	D22	C4815	K19	C4843	K19	C4863	K20	C4884	K19	C4905	H19	C6326	I16	C7510	I6	C7535	J7	C7668	I10	L1402	E20	L7514	J10	L7652	J11	R2102	D20	R4406	K18	R6301	I15	R7514	I8	V6300	K15	Z7501	J9	J3300	J3	J4951	I18	J9342	J17
C1407	E20	C2200	D20	C4400	K18	C4816	I18	C4844	H19	C4864	K20	C4885	H20	C4906	I21	C6327	J16	C7511	I7	C7536	J6	C7669	J11	L1403	D18	L7515	K10	M	R2103	D21	R4800	H18	R6306	J15	R7517	I8	X	Z7503	J7	J3301	H3	J6300	I15	J9343	I17		
C1408	E20	C2262	C21	C4403	K18	C4827	K19	C4845	H18	C4865	K20	C4886	I21	C4907	H19	C6328	I16	C7512	I6	C7537	J6	C7670	J11	L2110	I22	L7516	J10	M2110	I23	R2104	C20	R4809	H20	R6312	K15	R7650	K10	X1353	G23	Z7504	K7	J3302	H3	J6301	I15		
C1410	E20	C2263	C21	C4800	I21	C4828	H19	C4846	K18	C4866	I21	C4887	J21	C4908	I21	C6329	J15	C7513	I6	C7538	J6	C7671	I10	L2111	J22	L7517	K7	N	R2105	C20	R4821	K18	R6313	K15	R7651	I11	X2101	G3	Z7505	J8	J3303	J3	J9200	I17			
C1411	E20	C4100	D19	C4801	J21	C4829	I21	C4847	J21	C4867	I21	C4888	J18	C4910	H21	C6330	J16	C7514	J6	C7604	J9	C7672	J11	L2130	E21	L7518	J6	N1140	G20	R2108	C20	R4822	K19	R6314	K15	R9212	J18	X2102	F3	Z7650	J11	J4100	D19	J9201	I17		
C1413	E18	C4101	D19	C4802	J21	C4830	I21	C4848	J21	C4869	I21	C4889	I21	C4912	H20	C6331	J15	C7515	J6	C7655	J11	C7673	I11	L2161	D21	L7520	J9	N4100	D19	R2110	J22	R4825	H20	R6315	K15	S	X2105	B20	TST points	J4101	D20	J9202	I17				
C1414	E18	C4102	D20	C4803	I21	C4831	I21	C4850	J21	C4870	I21	C4890	H21	C4950	J18	C6332	I14	C7516	J7	C7656	I11	C7674	I10	L2162	C21	L7521	K9	N6301	J15	R2196	D21	R4832	I21	R6316	J15	S4400	K6	X3300	F2	J1140	G21	J4102	D20	J9203	I17		

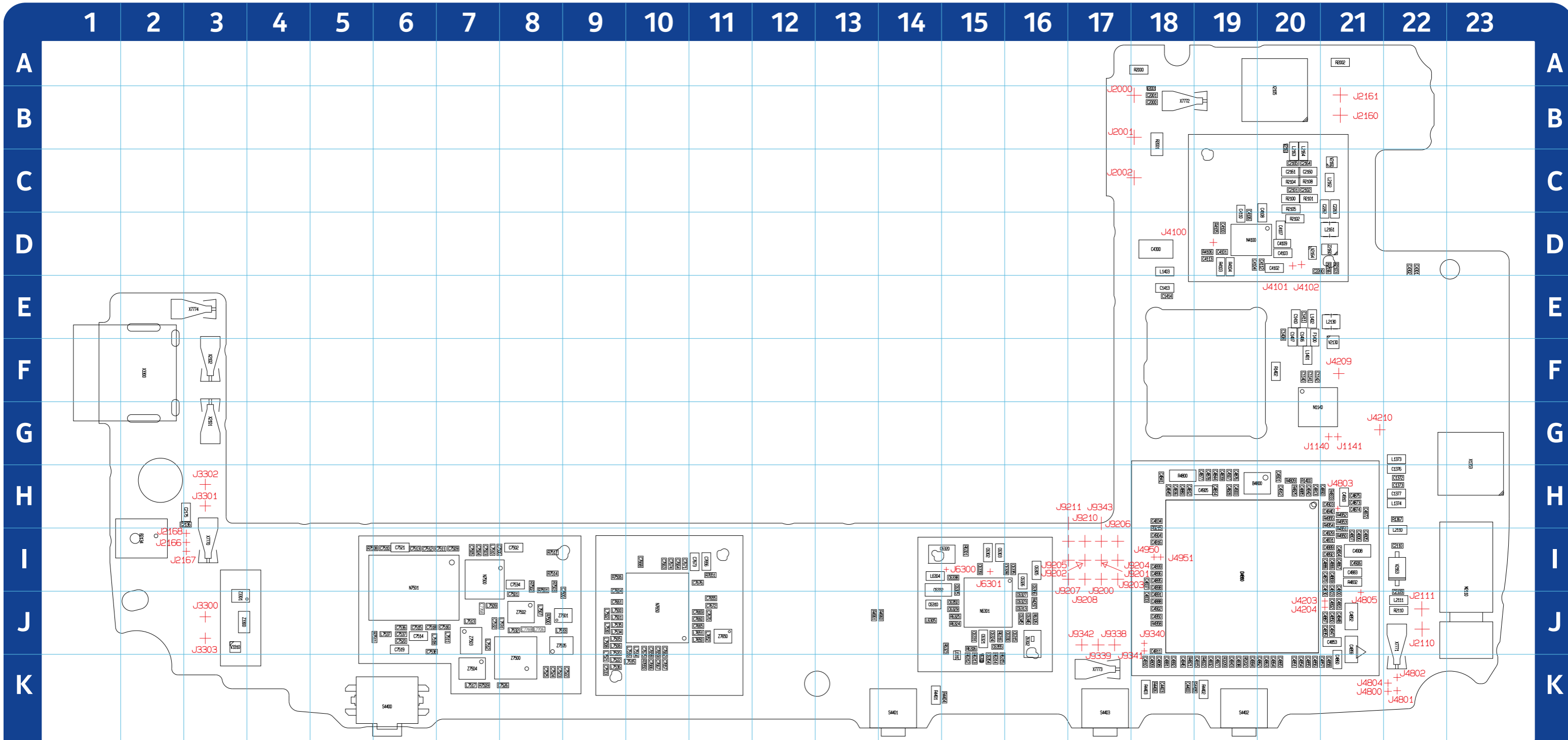

	1	2	3	4	5	6	7	8	9	10	11	12	13	14	15	16	17	18	19	20	21	22	23																										
B	C2000	B18	C4103	D20	C4804	I21	C4832	K19	C4851	K20	C4872	H21	C4891	J18	C6302	I15	C6335	I16	C7511	I7	C7536	J6	C7669	J11	L1401	F20	L7507	J8	L7533	J8	R	R4104	D19	R4951	I21	R6325	J15	S4402	K19	X7771	J22	J1140	G21	J4102	D20	J9203	I17		
B2134	I2	C2001	B18	C4104	D19	C4805	I21	C4833	J18	C4852	J21	C4873	H21	C4892	I21	C6303	I15	C6338	I15	C7512	I6	C7537	J6	C7670	J11	L1402	E20	L7508	J9	L7534	J9	R1367	H22	R4105	D19	R4952	H21	R6326	J16	S4403	K17	X7772	B18	J1141	G21	J4203	J21	J9204	I17
B4800	H20	C2101	C20	C4106	D19	C4806	I21	C4834	H18	C4853	J21	C4874	H21	C4895	I18	C6305	I16	C6339	I15	C7513	I6	C7538	J6	C7671	I10	L1403	D18	L7509	J7	L7535	J9	R1400	H20	R4106	D19	R4953	H21	R7500	J8	V	X7773	K17	J2000	B18	J4204	J21	J9205	I17	
C	C2102	C20	C4107	D20	C4807	I21	C4835	J21	C4854	K20	C4875	H21	C4896	I18	C6310	J14	C6345	J16	C7514	J6	C7604	I9	C7672	J11	L2110	I22	L7510	I7	L7536	K9	R1402	F20	R4297	J16	R4954	H21	R7501	I8	V2001	B18	X7774	E3	J2001	B18	J4209	F21	J9206	I17	
C1140	F20	C2109	J22	C4108	D20	C4808	K18	C4836	H18	C4855	K20	C4876	H19	C4898	I18	C6313	J16	C6346	J16	C7515	J6	C7655	J11	C7673	I11	L2111	J22	L7511	J7	L7537	J6	R2000	A18	R4401	K14	R4955	H21	R7502	I8	V2130	F21	Z	J2002	C18	J4210	G21	J9207	I17	
C1141	F20	C2110	I22	C4109	D20	C4809	K18	C4837	I18	C4856	K20	C4877	H19	C4899	I18	C6315	J16	C6350	J15	C7516	J7	C7656	I11	C7674	I10	L2130	E21	L7512	J7	L7650	J11	R2001	B18	R4402	K19	R4958	I18	R7503	I8	V2160	C21	Z2160	D21	J2110	J22	J4800	K22	J9208	I17
C1142	F20	C2136	H3	C4110	D19	C4810	K18	C4838	K19	C4857	K21	C4878	H19	C4900	H19	C6320	I15	C6354	K15	C7518	J6	C7657	K10	C7675	J10	L2161	D21	L7513	J7	L7651	J11	R2002	A21	R4403	K18	R4960	J14	R7506	I9	V2161	B20	Z2161	A19	J2111	J22	J4801	K22	J9210	I17
C1372	H22	C2160	C20	C4112	D20	C4811	J18	C4839	H19	C4858	K21	C4880	H18	C4901	H20	C6321	J15	C6355	J15	C7519	J6	C7658	J10	C7676	I11	L2162	C21	L7514	J10	L7652	J11	R2100	C20	R4404	K15	R4961	J13	R7508	I5	V2163	I22	Z3300	J3	J2160	B21	J4802	K22	J9211	I17
C1373	H22	C2161	C20	C4113	D19	C4812	H18	C4840	H21	C4859	J21	C4881	K18	C4902	J18	C6323	J16	C6356	I16	C7520	J6	C7659	J10	C7768	J7	L2163	C20	L7515	K10	L7706	J8	R2101	C20	R4405	K19	R5202	K19	R7509	K7	V2164	D20	Z3301	J3	J2161	B21	J4803	H21	J9338	J17
C1376	H22	C2164	C20	C4300	D18	C4813	H20	C4841	H18	C4860	K21	C4882	K18	C4903	H21	C6324	J15	C7500	J9	C7521	I6	C7660	J11	C7769	J8	L2164	C20	L7516	J10	M	R2102	D20	R4406	K18	R6301	I15	R7511	J6	V3310	J3	Z6302	J16	J2166	I3	J4804	K22	J9339	J17	
C1377	H22	C2165	C20	C4301	D22	C4814	H19	C4842	H20	C4862	K20	C4883	I21	C4904	I18	C6325	I15	C7501	J8	C7522	K9	C7661	J9	D	L6304	I14	L7517	K7	M2110	I23	R2103	D21	R4800	H18	R6306	J15	R7514	I8	V6300	K15	Z7500	K8	J2167	I3	J4805	J21	J9340	J18	
C1406	E20	C2175	H3	C4302	D22	C4815	K19	C4843	K19	C4863	K20	C4884	K19	C4905	H19	C6326	I16	C7502	I8	C7523	K8	C7662	J10	D4800	I19	L6305	J14	L7518	J6	N	R2104	C20	R4809	H20	R6312	K15	R7517	I8	X	Z7501	J9	J2168	I3	J4950	I18	J9341	J18		
C1407	E20	C2200	D20	C4400	K18	C4816	I18	C4844	H19	C4864	K20	C4885	H20	C4906	I21	C6327	J16	C7503	I7	C7524	K8	C7663	I10	D4810	I19	L6310	K15	L7520	J9	N1140	G20	R2105	C20	R4821	K18	R6313	K15	R7650	K10	X1353	G23	Z7502	J8	J3300	J3	J4951	I18	J9342	J17
C1408	E20	C2262	C21	C4403	K18	C4827	K19	C4845	H18	C4865	K20	C4886	I21	C4907	H19	C6328	I16	C7504	I7	C7525	K8	C7664	I10	F	L7500	J9	L7521	K9	N4100	D19	R2108	C20	R4822	K19	R6314	K15	R7651	I11	X2101	G3	Z7503	J7	J3301	H3	J6300	I15	J9343	I17	
C1410	E20	C2263	C21	C4800	I21	C4828	H19	C4846	K18	C4866	I21	C4887	J21	C4908	I21	C6329	J15	C7505	I7	C7526	K8	C7665	J11	F1400	E20	L7501	J9	L7522	K9	N6301	J15	R2110	J22	R4825	H20	R6315	K15	R9215	I18	X2102	F3	Z7504	K7	J3302	H3	J6301	I15		
C1411	E20	C4100	D19	C4801	J21	C4829	I21	C4847	J21	C4867	I21	C4888	J18	C4910	H21	C6330	J16	C7506	I7	C7532	J7	C7666	K10	L	L7502	J9	L7530	J9	N7500	I7	R2196	D21	R4832	I21	R6316	J15	S	X2105	B20	Z7505	J8	J3303	J3	J9200	I17				
C1413	E18	C4101	D19	C4802	J21	C4830	I21	C4848	J21	C4869	I21	C4889	I21	C4912	H20	C6331	J15	C7509	I7	C7533	K9	C7667	K10	L1373	G22	L7505	J9	L7531	J8	N7501	I6	R3209	K19	R4833	H21	R6323	J15	S4400	K6	X3300	F2	Z7650	J11	J4100	D19	J9201	I17		
C1414	E18	C4102	D20	C4803	I21	C4831	I21	C4850	J21	C4870	I21	C4890	H21	C4950	J18	C6332	I14	C7510	I6	C7534	I8	C7668	I10	L1374	H22	L7506	J9	L7532	J8	N7650	J10	R4103	D19	R4950	I21	R6324	J15	S4401	K14	X7770	I3	TST points	J4101	D20	J9202	I17			

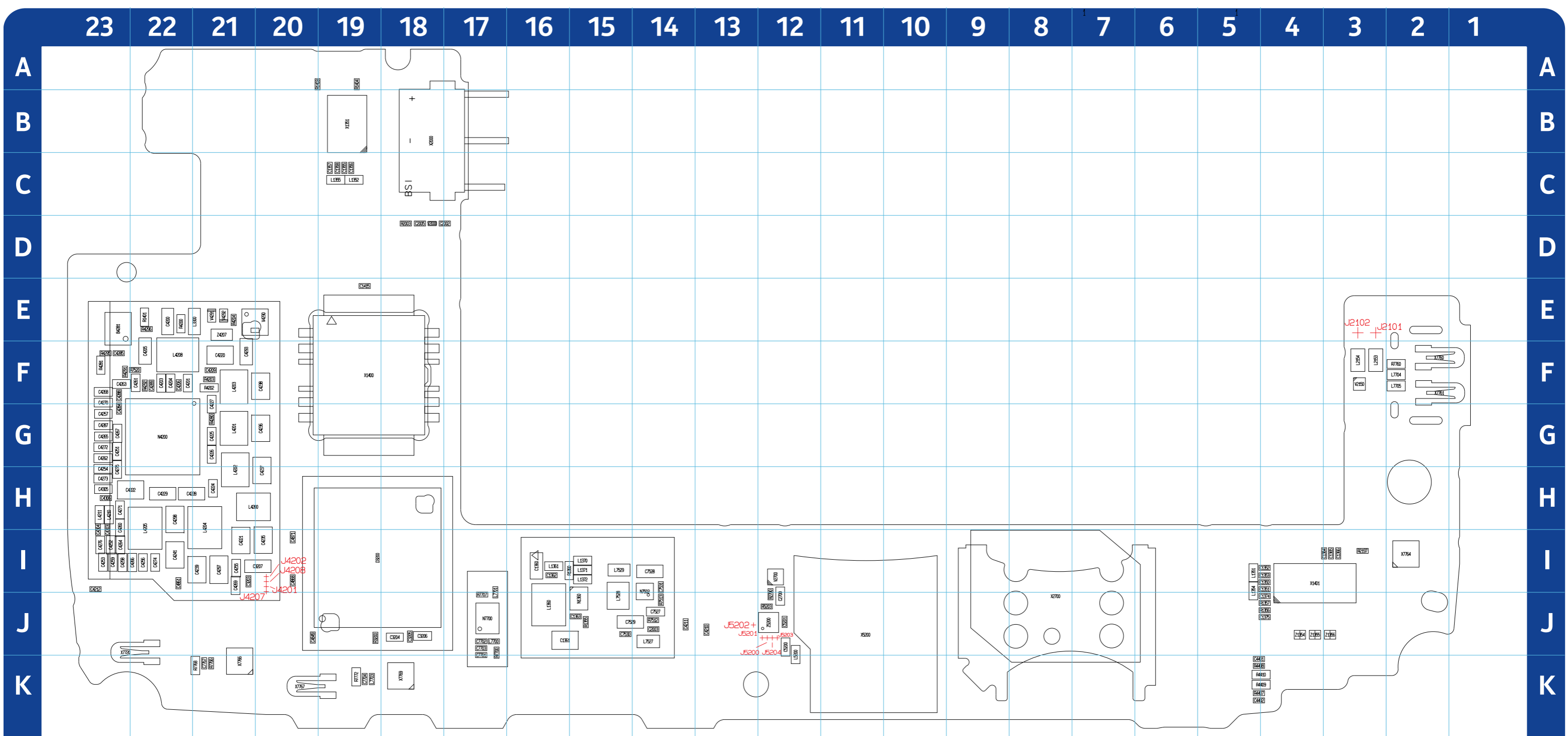

	23	22	21	20	19	18	17	16	15	14	13	12	11	10	9	8	7	6	5	4	3	2	1		
B	C1374	J4	C4209	F21	C4241	I22	C4268	F23	C4304	I23	C7703	J17	L4200	H21	N	R4202	F21	R7707	J17	X5200	J11	Z4206	F22		
B4281	E23	C1375	J4	C4210	J13	C4251	G23	C4269	I21	C4305	H23	C7704	K19	L4201	G21	N1360	J15	R4203	F21	R7760	F2	X7720	J22	Z4207	E21
C	C1415	E19	C4211	J14	C4252	I23	C4270	F23	C4306	H23	C7767	K21	L4202	H21	N4200	G22	R4204	E21	R7766	K21	X7760	F2	Z5200	J12	
C1350	I4	C2002	D17	C4212	I23	C4253	I23	C4271	H23	C4401	K5	D	L4203	F21	N7502	I14	R4280	G21	R7768	K21	X7761	F2	TST points		
C1351	I4	C2003	J14	C4220	F21	C4254	H23	C4272	G23	C4402	K5	D3200	I19	L4204	H21	N7700	J17	R4281	F23	R7772	K19	X7764	I2	J2101	E3
C1352	I4	C2005	D18	C4221	I21	C4255	I21	C4273	H23	C4849	J20	L	L4205	H22	R	R4291	F23	V	X7766	K21	X7766	K21	J2102	E3	
C1353	I4	C2700	J12	C4222	H22	C4256	I22	C4274	I22	C4861	I22	L1351	I5	L4208	F22	R1355	J15	R4292	F22	V2000	D18	X7767	K20	J4201	I20
C1355	C19	C3203	I21	C4224	H21	C4257	G23	C4275	H23	C4868	I20	L1352	C19	L4210	H23	R1356	J4	R4295	F23	V2150	F3	X7769	K18	J4202	I20
C1356	C19	C3204	J18	C4225	G21	C4258	I23	C4276	I23	C4871	I20	L1354	I5	L4211	H23	R1357	J4	R4296	E22	V2700	I12	Z	J4207	I20	
C1357	C19	C3205	J18	C4226	G21	C4259	I23	C4284	G23	C5200	J12	L1355	C19	L5200	J12	R1360	I16	R4407	K5	V4290	E21	Z1354	J4	J4208	I20
C1358	C19	C3206	J18	C4227	G21	C4260	H23	C4285	F23	C5201	J12	L1360	J16	L7527	J14	R1401	E22	R4408	K5	V4291	E21	Z1355	J4	J5200	J12
C1360	I16	C3207	I20	C4228	H22	C4261	F22	C4287	G23	C7527	J14	L1361	I16	L7528	J15	R1403	A20	R4409	K4	V4292	E21	Z1356	J3	J5201	J12
C1361	J16	C4200	E22	C4229	H22	C4262	G23	C4288	F23	C7528	I14	L1370	I15	L7529	I15	R1404	A19	R4410	K4	X	Z4200	H21	J5202	J13	
C1362	I16	C4201	F22	C4235	I20	C4263	F23	C4289	F22	C7529	J15	L1371	I15	L7700	J17	R2003	D18	R5203	J12	X1351	B19	Z4201	G21	J5203	J12
C1363	J15	C4203	F22	C4236	G20	C4264	I23	C4293	F21	C7530	J15	L1372	I15	L7701	J17	R2197	I3	R7512	J14	X1400	F19	Z4202	G21	J5204	J12
C1364	I3	C4204	F22	C4237	H20	C4265	G23	C4297	I21	C7531	I14	L2153	F3	L7703	K19	R2700	J12	R7513	J14	X1401	I4	Z4203	F21		
C1365	I3	C4205	F22	C4238	F20	C4266	I22	C4298	H22	C7701	K17	L2154	F3	L7704	F2	R3200	J19	R7520	F22	X2000	B18	Z4204	I21		
C1366	I3	C4206	F22	C4239	I21	C4267	G23	C4303	I23	C7702	J17	L3300	E21	L7705	F2	R4200	E22	R7700	J17	X2700	J8	Z4205	H22		

