

Service Schematics

NOKIA 3250

Introduction

Exploded view and component disposal

IMPORTANT:

This document is intended for use by authorized NOKIA service centers only.

“Service Schematics” was created with focus on customer care. The purpose of this document is to provide further technical repair information for NOKIA mobile phones on Level 3/4 service activities. It contains additional information such as e.g. “Component finder”, “Frequency band table” or “Antenna switch table”. The “Signal overview” page gives a good and fast overview about the most important signals and voltages on board. Saving process time and improving the repair quality is the aim of this document. It is to be used additionally to the service manual and other training or service information such as Service Bulletins.

All measurements were made using following equipment:

Nokia repair SW	: Phoenix version 2005.12.5.90
Oscilloscope	: Fluke PM 3380A/B
Spectrum Analyzer	: Advantest R3162 with an analog probe
RF-Generator / GSM Tester	: Rhode & Schwarz CMU 200
Multimeter	: Fluke 73 Series II

While every endeavour has been made to ensure the accuracy of this document, some errors may exist. If the reader finds any errors, NOKIA should be notified in writing.

Please send E-Mail to: training.sace@nokia.com

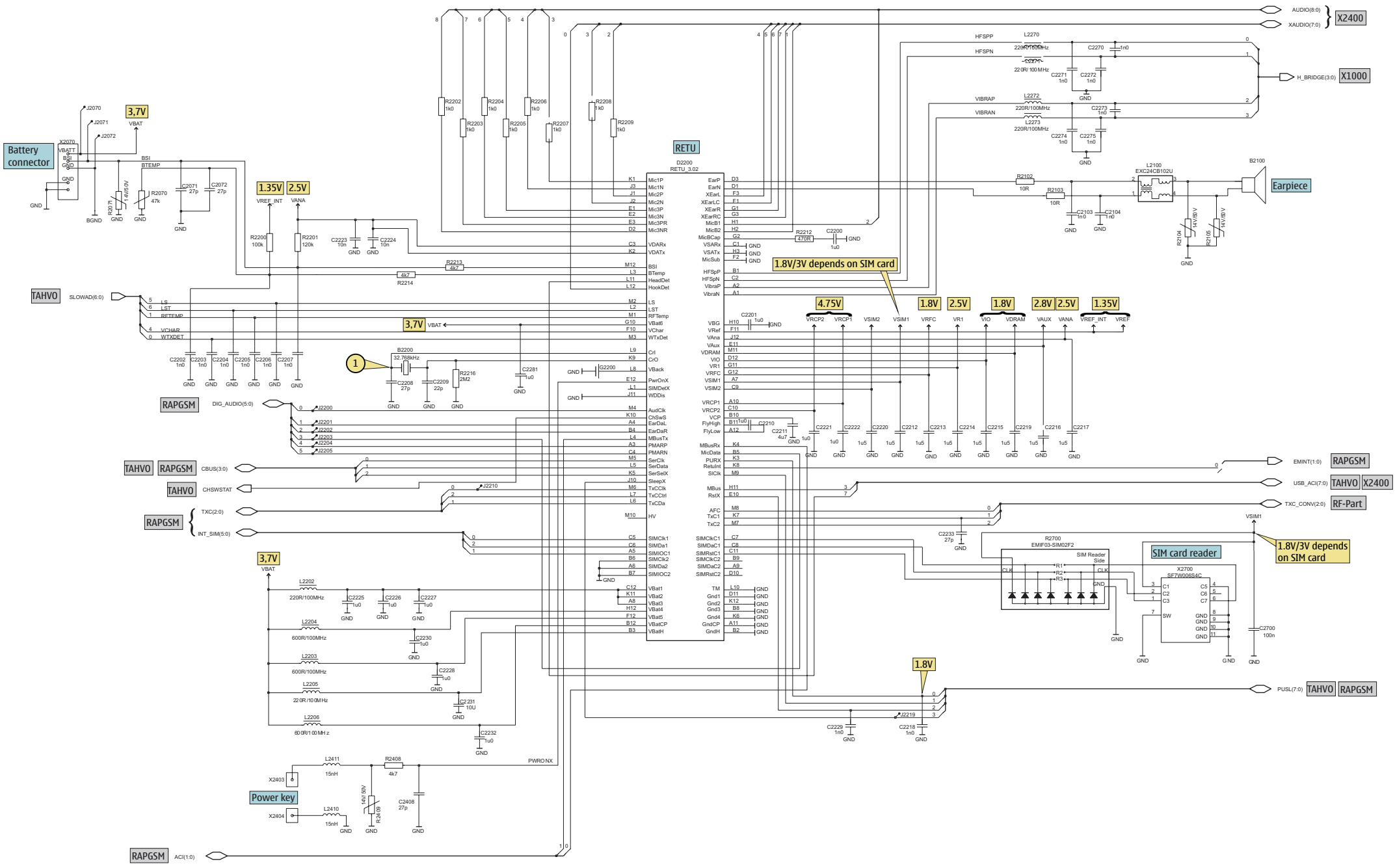
Copyright © NOKIA

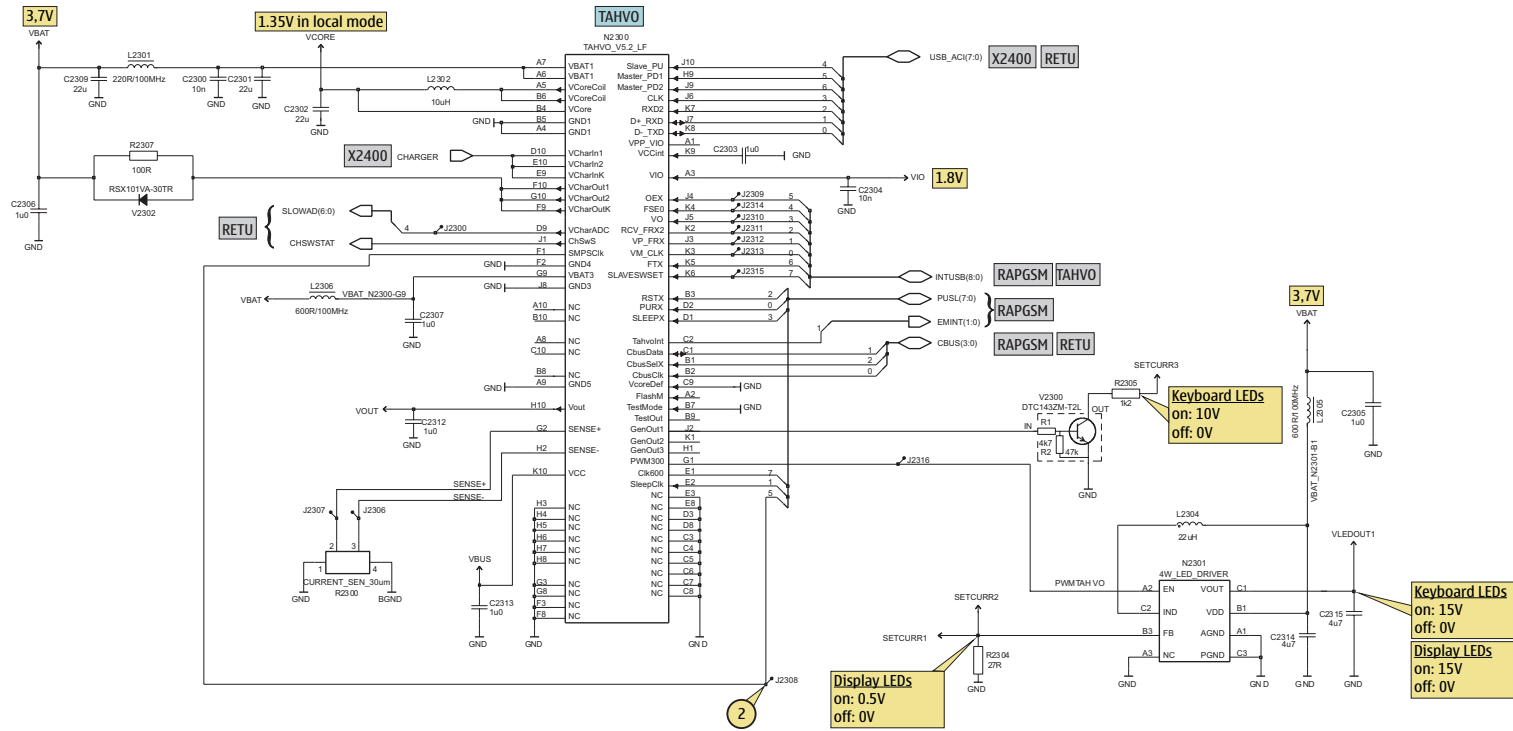
This material, including documentation and any related computer programs is protected by copyright, controlled by NOKIA. All rights are reserved. Copying, including reproducing, modifying, storing, adapting or translating any or all of this material requires the prior written consent of NOKIA. This material also contains confidential information, which may not be disclosed to others without the prior written consent of NOKIA.

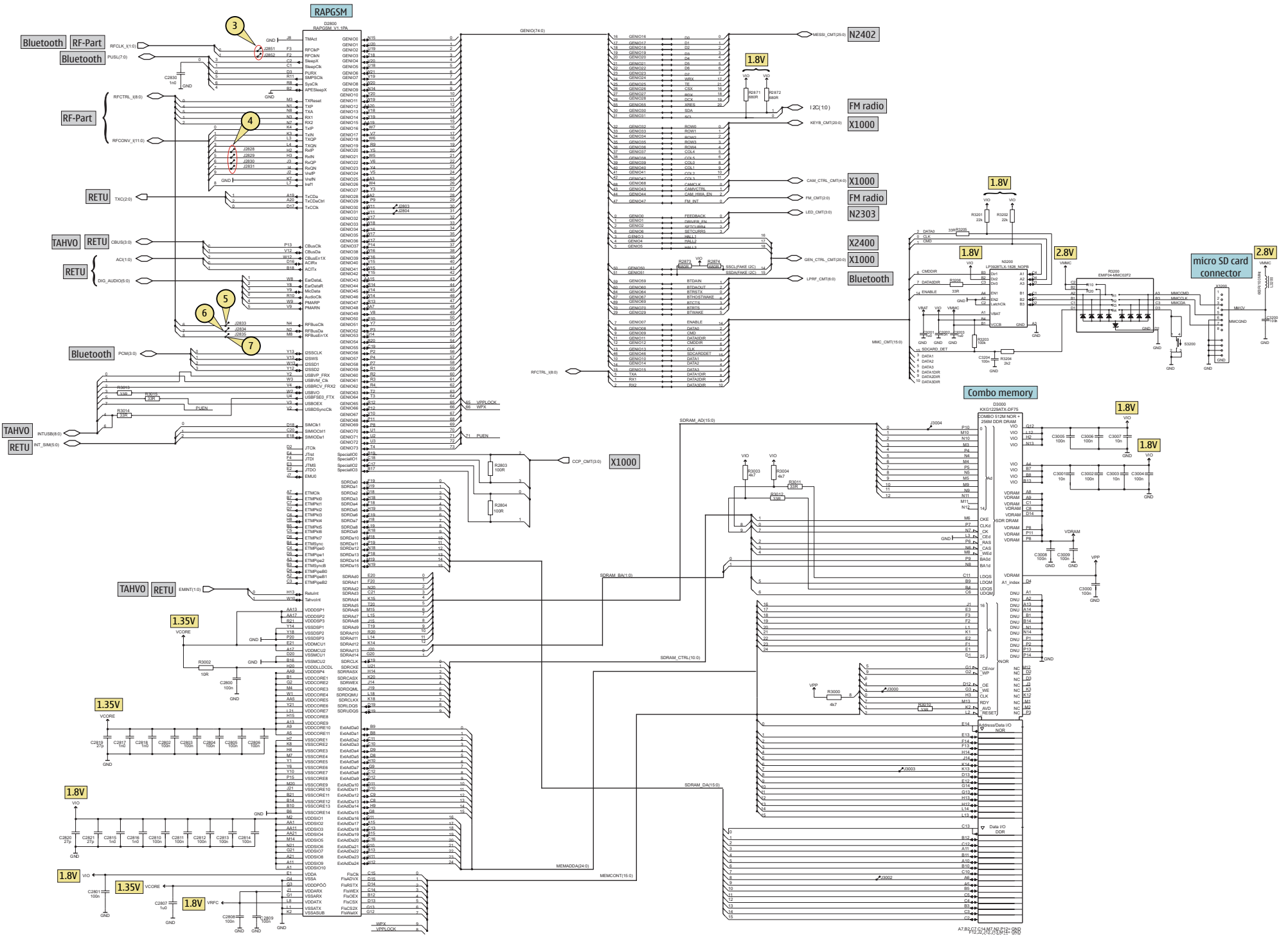
RM-38

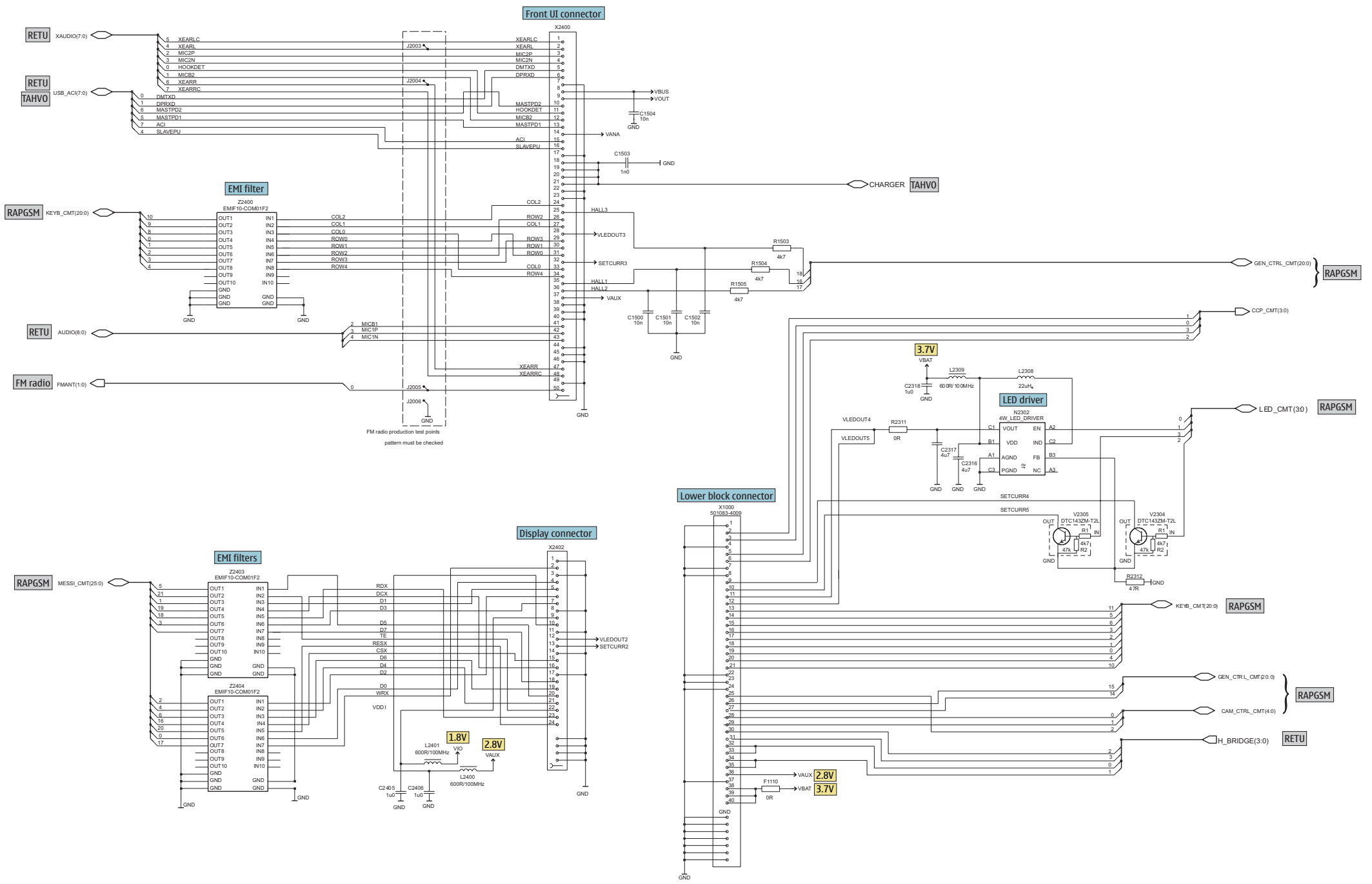


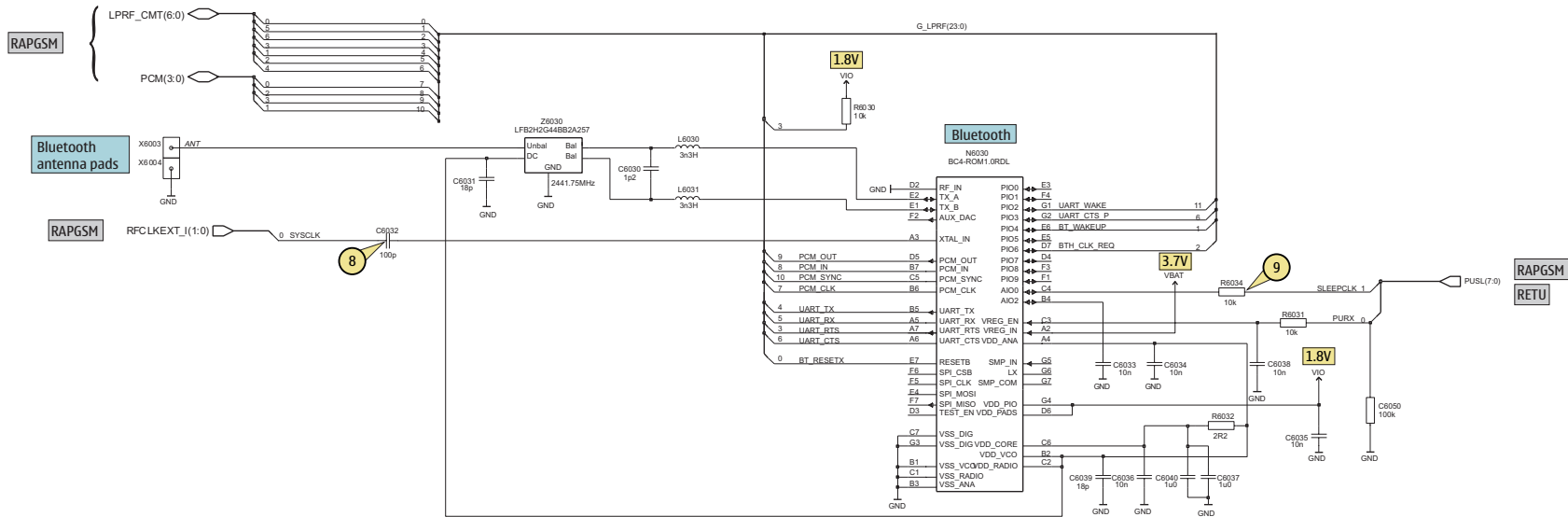
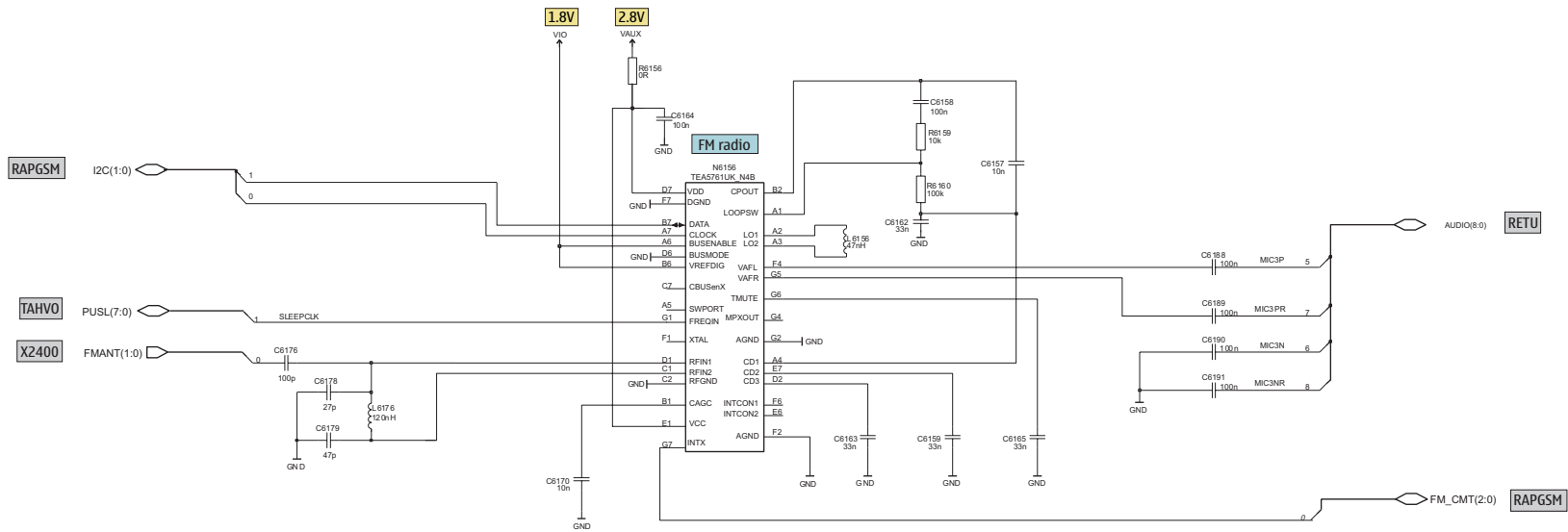
Table of Contents	Page
Front page	1
RAPGSM, memory & micro SD card	2
RETU	3
TAHVO	4
Front UI, display & B2B connectors	5
FM radio & Bluetooth	6
RF-part	7
Signal overview	8
Component finder	9





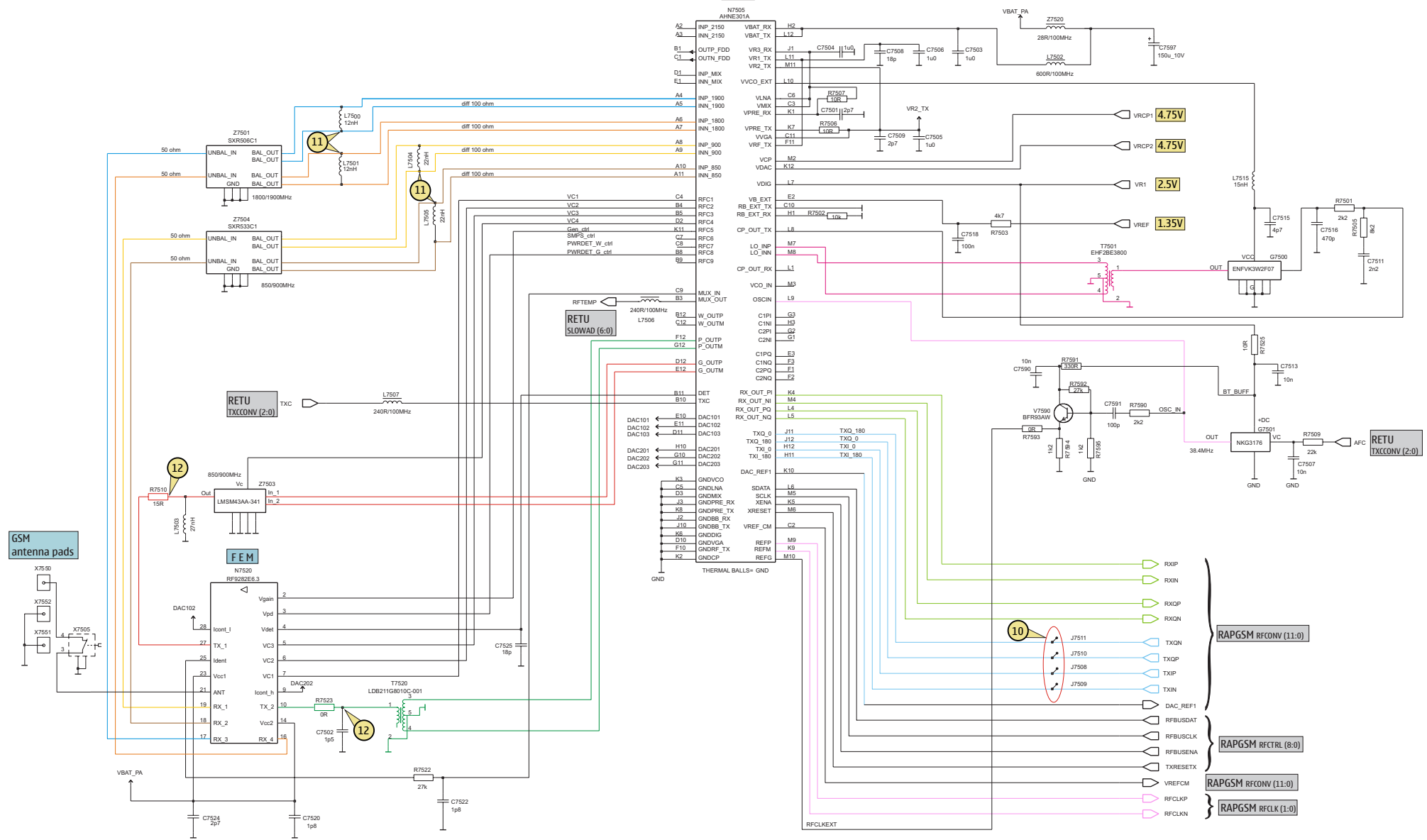


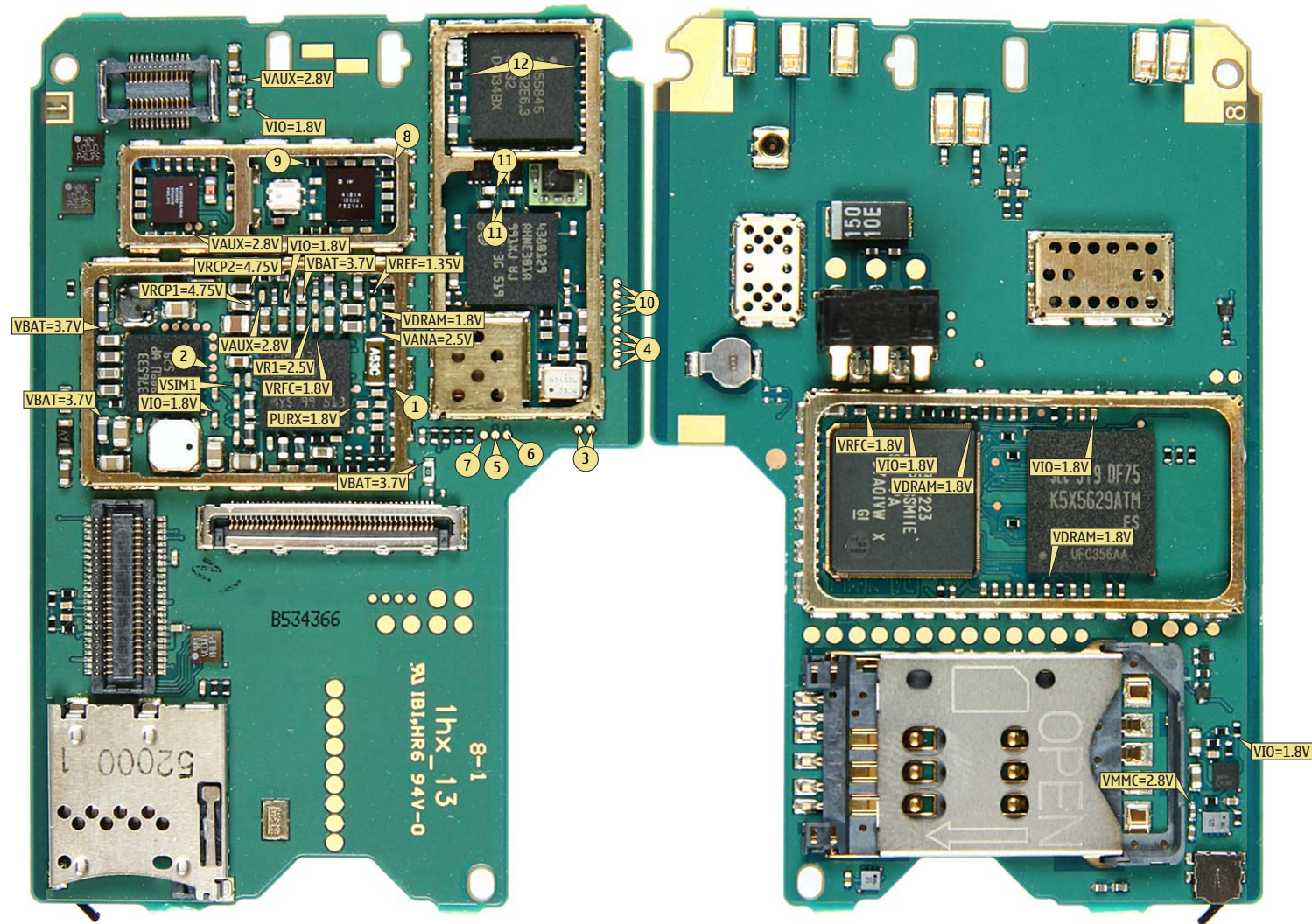
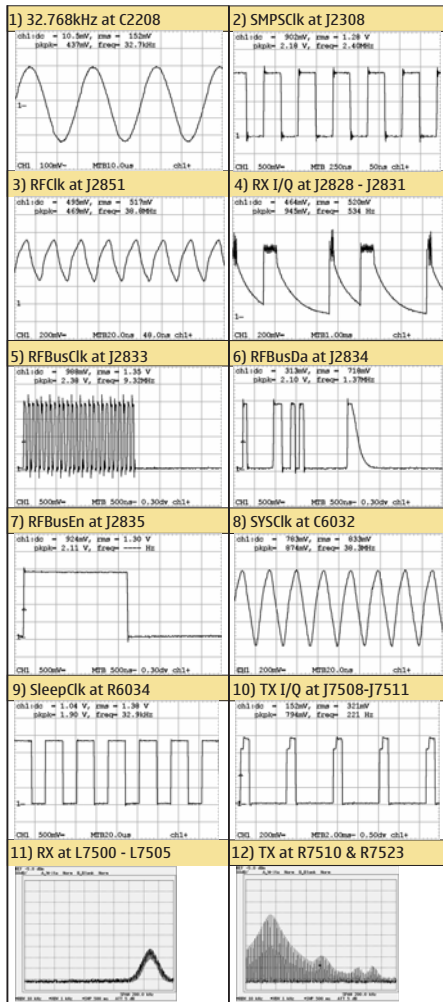




Band	Channel	RX	VCO	TX	VCO
GSM 900	37	942.4MHz	3769.6MHz	897.4MHz	3589.6MHz
GSM 1800	700	1842.8MHz	3685.6MHz	1747.8MHz	3495.6MHz
GSM 1900	661	1960MHz	3920.0MHz	1880MHz	3760.0MHz

AHNE





B	C2312	G2	C6159	E3	J2307	F6	L2301	H2	R2307	G2	V7590	E9
B2100	B6	C2313	F2	C6162	D4	J2308	G4	L2302	H3	R2311	F3	X
B2200	G6	C2314	F3	C6163	C3	J2309	F3	L2304	F3	R2312	K2	X1000
C	C2315	E4	C6164	E3	J2310	F3	L2305	F2	R2408	E5	X2060	N5
C1110	I7	C2316	E3	C6165	D3	J2311	F4	L2306	G1	R2409	D5	X2070
C1500	I1	C2317	F3	C6167	C4	J2312	F3	L2308	F4	R2700	O7	X2400
C1501	K1	C2318	E4	C6168	D4	J2313	F4	L2309	F4	R2803	G6	X2402
C1502	L4	C2319	F3	C6170	C4	J2314	F4	L2400	B4	R2804	G6	X2403
C1503	K3	C2405	B4	C6176	D3	J2315	F3	L2401	B4	R2871	H7	X2404
C1504	B3	C2406	B4	C6178	C3	J2316	F4	L2410	C6	R2872	H7	X2700
C2071	F7	C2408	E5	C6179	C3	J2803	D3	L2411	C5	R2873	H8	X3200
C2072	O3	C2700	O7	C6188	D3	J2804	D3	L3200	N2	R2874	H8	X6003
C2103	D5	C2800	G5	C6189	D3	J2828	F10	L6030	D5	R3000	I4	X6004
C2104	D5	C2801	H8	C6190	H7	J2829	F10	L6031	D5	R3002	J6	X7505
C2200	H5	C2802	G6	C6191	H7	J2830	F10	L6156	D4	R3003	J6	X7550
C2201	F6	C2803	J7	C7501	F7	J2831	G10	L6176	C3	R3004	G4	X7551
C2202	E6	C2804	G7	C7502	B8	J2833	H8	L7500	D8	R3010	H5	X7552
C2203	G6	C2805	I8	C7503	F9	J2834	H8	L7501	D8	R3011	H5	Z
C2204	G6	C2806	I5	C7504	E7	J2835	H8	L7502	F9	R3012	I5	Z2400
C2205	H6	C2807	G8	C7505	F9	J2851	H9	L7503	B10	R3013	H2	Z2403
C2206	G6	C2808	G7	C7506	F9	J2852	H10	L7504	D8	R3014	H2	Z2404
C2207	F6	C2809	I8	C7507	F9	J3000	G4	L7505	D8	R3015	H2	Z6030
C2208	G7	C2810	G6	C7508	F9	J3002	I5	L7506	D8	R3200	N2	Z7501
C2209	G7	C2811	G5	C7509	F9	J3003	H5	L7507	D9	R3201	L1	Z7503
C2210	F4	C2812	J5	C7511	F8	J3004	G3	L7515	F8	R3202	L2	Z7504
C2211	F4	C2813	I8	C7513	F9	J3100	J7	N	R3203	N1	Z7520	C7
C2212	G4	C2814	H8	C7515	F7	J3101	I8	N2300	G3	R3204	M2	
C2213	F5	C2815	I8	C7516	F8	J3102	L6	N2301	E3	R3205	L2	
C2214	F5	C2816	G4	C7518	E9	J3103	L6	N2302	E3	R3206	M1	
C2215	F5	C2817	G7	C7520	C8	J3104	M6	N3200	M1	R6030	D6	
C2216	F5	C2818	I5	C7522	C9	J3105	L6	N6030	D6	R6031	D6	
C2217	F6	C2819	I8	C7523	C7	J3106	L6	N6156	D3	R6032	D6	
C2218	G6	C2820	H7	C7524	C9	J3107	K8	N7505	E8	R6034	C5	
C2219	F6	C2821	J6	C7525	B9	J3108	K4	N7520	B9	R6050	D5	
C2220	G4	C2830	H8	C7590	E9	J3109	K4	R	R6156	E3		
C2221	E4	C3000	I4	C7591	F8	J3110	M6	R1110	H7	R6159	C4	
C2222	F4	C3001	J5	C7597	D7	J3111	K4	R1500	J1	R6160	C4	
C2223	H5	C3002	I5	D	J3112	K8	R1501	K1	R7501	F8		
C2224	H6	C3003	G5	D2200	G5	J3113	K7	R1502	L4	R7502	F7	
C2225	F6	C3004	G5	D2800	I7	J3115	K6	R1503	L4	R7503	E9	
C2226	F5	C3005	G4	D3000	I4	J3116	K8	R1504	K1	R7505	F8	
C2227	G4	C3006	J4	G	J3117	K7	R1505	J1	R7506	F9		
C2228	F5	C3007	G4	G2200	G9	J3118	K7	R2070	O3	R7507	F8	
C2229	G4	C3008	I4	G7500	G8	J3119	K3	R2071	E7	R7509	F9	
C2230	F6	C3009	J3	G7501	G9	J3120	K2	R2102	D5	R7510	B10	
C2231	H4	C3100	J3	T	J3121	H8	R2103	D5	R7522	B9		
C2232	F5	C3200	N2	I2003	K2	J3122	M6	R2104	C5	R7523	B8	
C2233	G7	C3201	L2	I2004	K2	J3123	N6	R2105	C5	R7525	F9	
C2270	H5	C3202	M2	I2005	G1	J3124	N6	R2200	E6	R7590	F9	
C2271	H5	C3203	M2	I2006	G2	J7508	E10	R2201	F6	R7591	F9	
C2272	H5	C3204	M1	I2060	K6	J7509	E10	R2202	H6	R7592	E8	
C2273	G4	C6030	D5	I2070	E8	J7510	F10	R2203	H6	R7593	E9	
C2274	G4	C6031	D5	I2071	E7	J7511	F10	R2204	H6	R7594	E8	
C2275	H4	C6032	C6	I2072	E6	L	R2205	H6	R7595	E8		
C2281	E5	C6033	C6	I2200	I6	L2100	D5	R2206	H6	S		
C2300	H3	C6034	C6	I2201	J7	L2202	E6	R2207	H6	S3200	O2	
C2301	H2	C6035	D6	I2202	J7	L2203	E5	R2208	H6	T		
C2302	H4	C6036	D6	I2203	J6	L2204	E6	R2209	H6	T7501	G8	
C2303	F2	C6037	D6	I2204	H6	L2205	E6	R2212	H5	T7520	B8	
C2304	G4	C6038	D6	I2205	G6	L2206	E5	R2213	F6	V		
C2305	F2	C6039	C6	I2210	G6	L2270	H5	R2214	E6	V2300	F1	
C2306	H1	C6040	D6	I2219	G5	L2271	H5	R2216	F7	V2302	H1	
C2307	G2	C6157	D4	I2300	G4	L2272	G4	R2304	E2	V2304	L2	
C2309	H2	C6158	D4	I2306	F6	L2273	H4	R2305	F1	V2305	K2	

