

3585i Top Level Overview

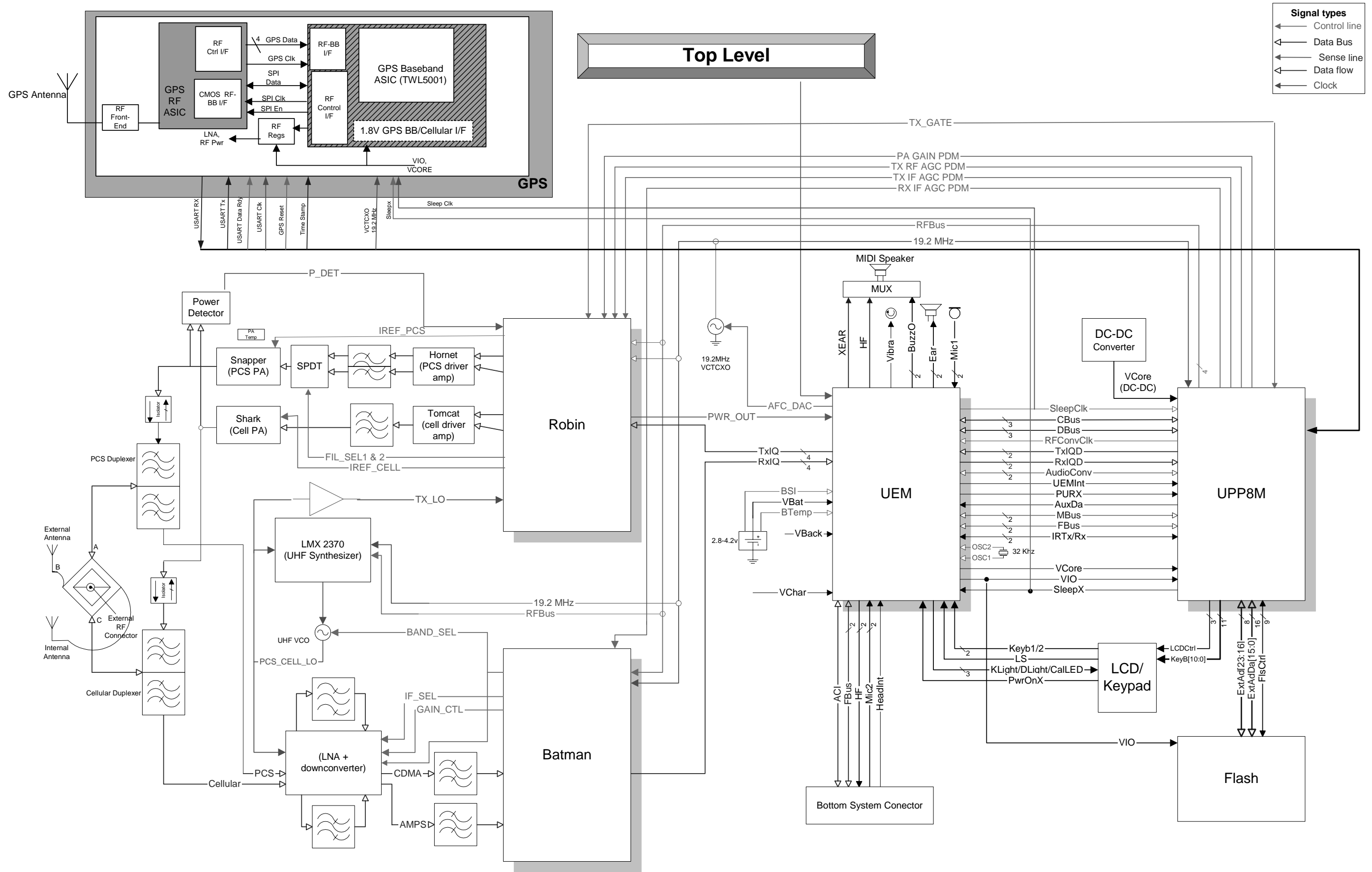

Audio

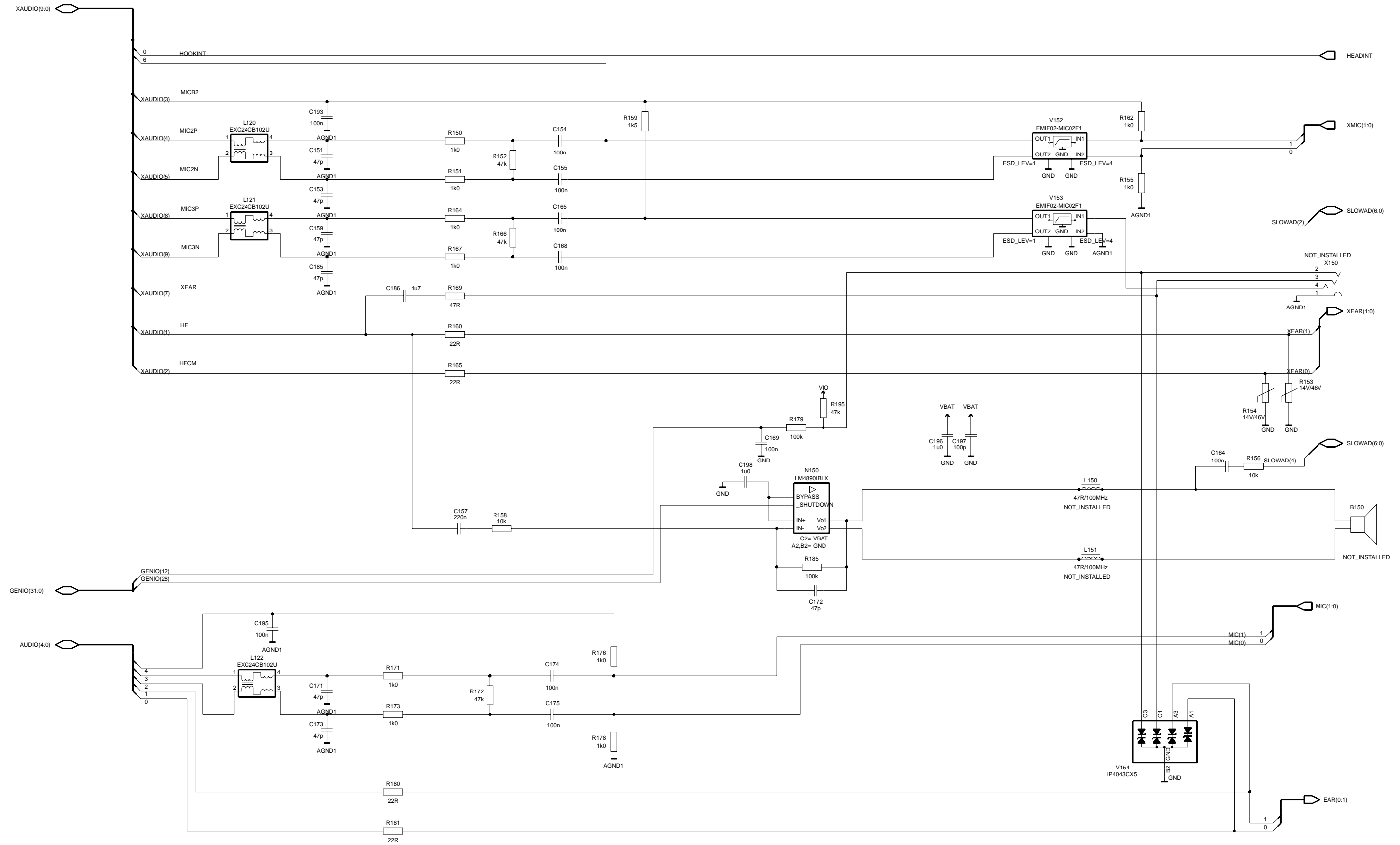

DCT4 Common Baseband

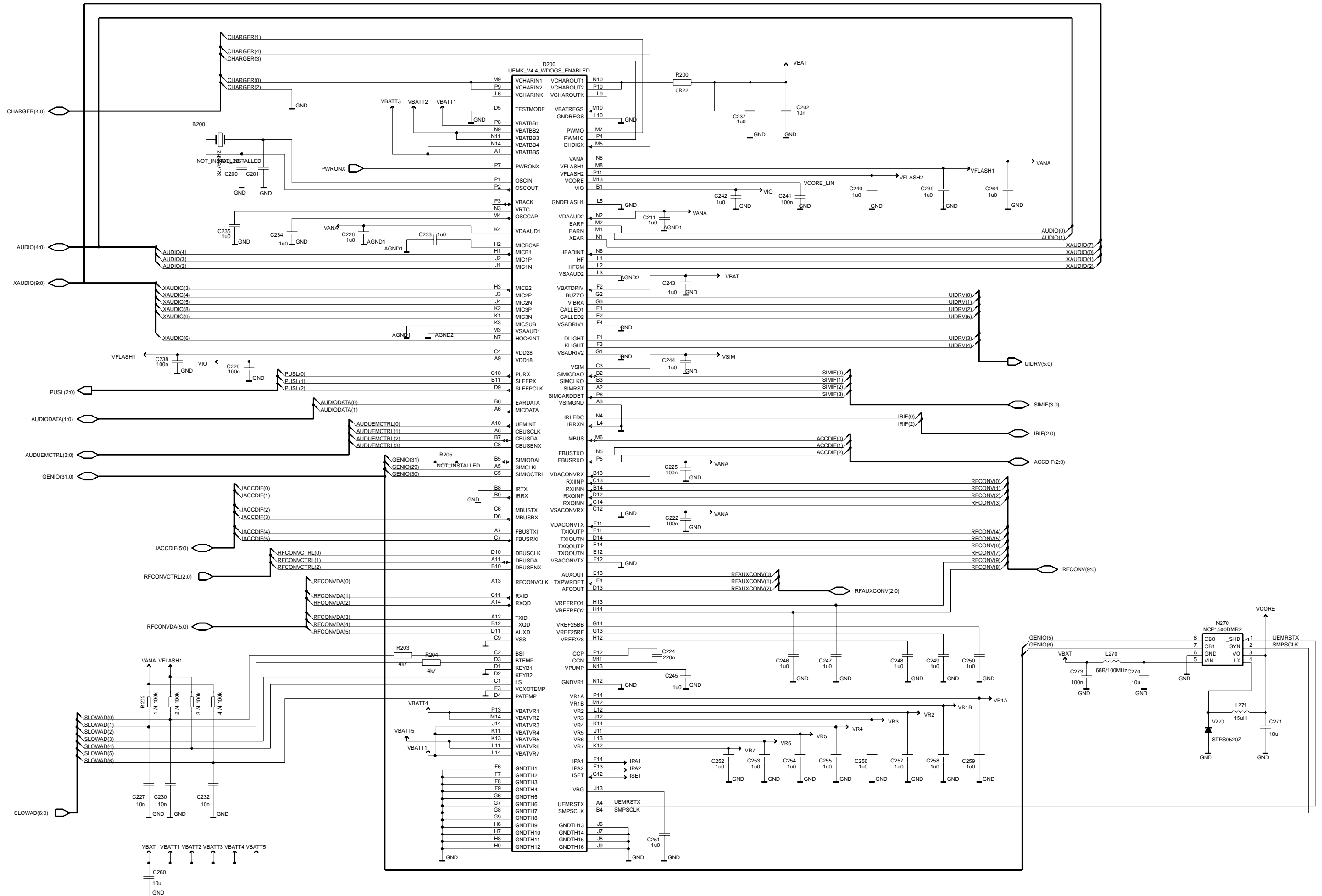

GPS RF Circuit Diagram

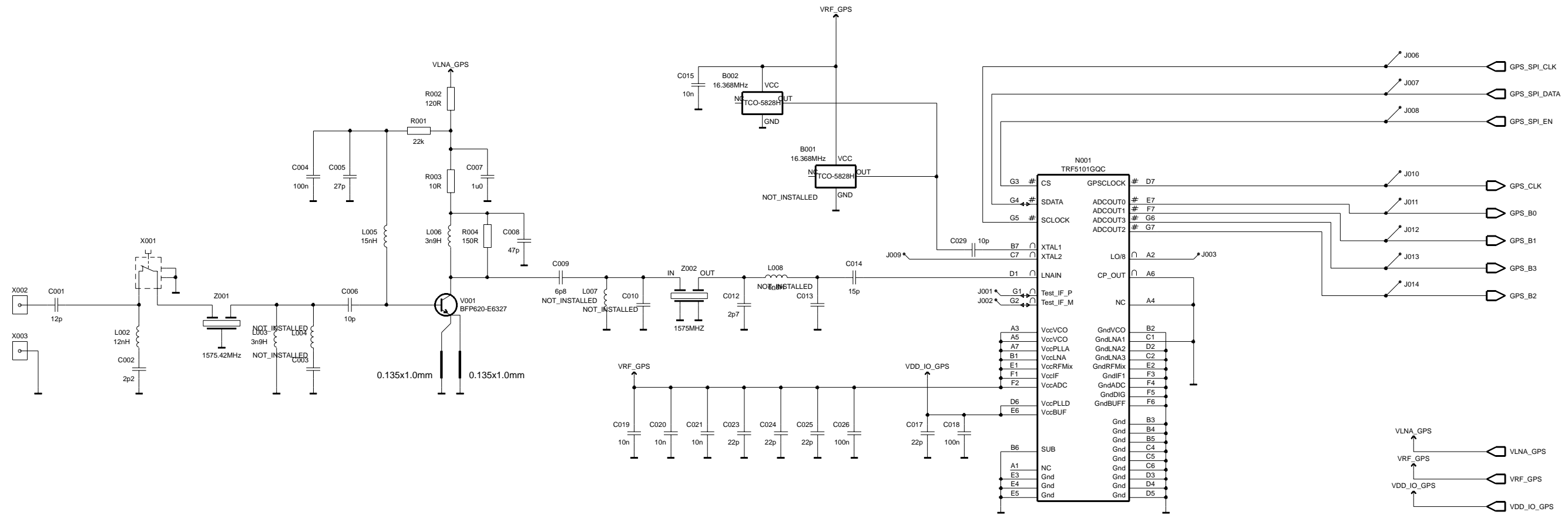

GPS Baseband Circuit Diagram

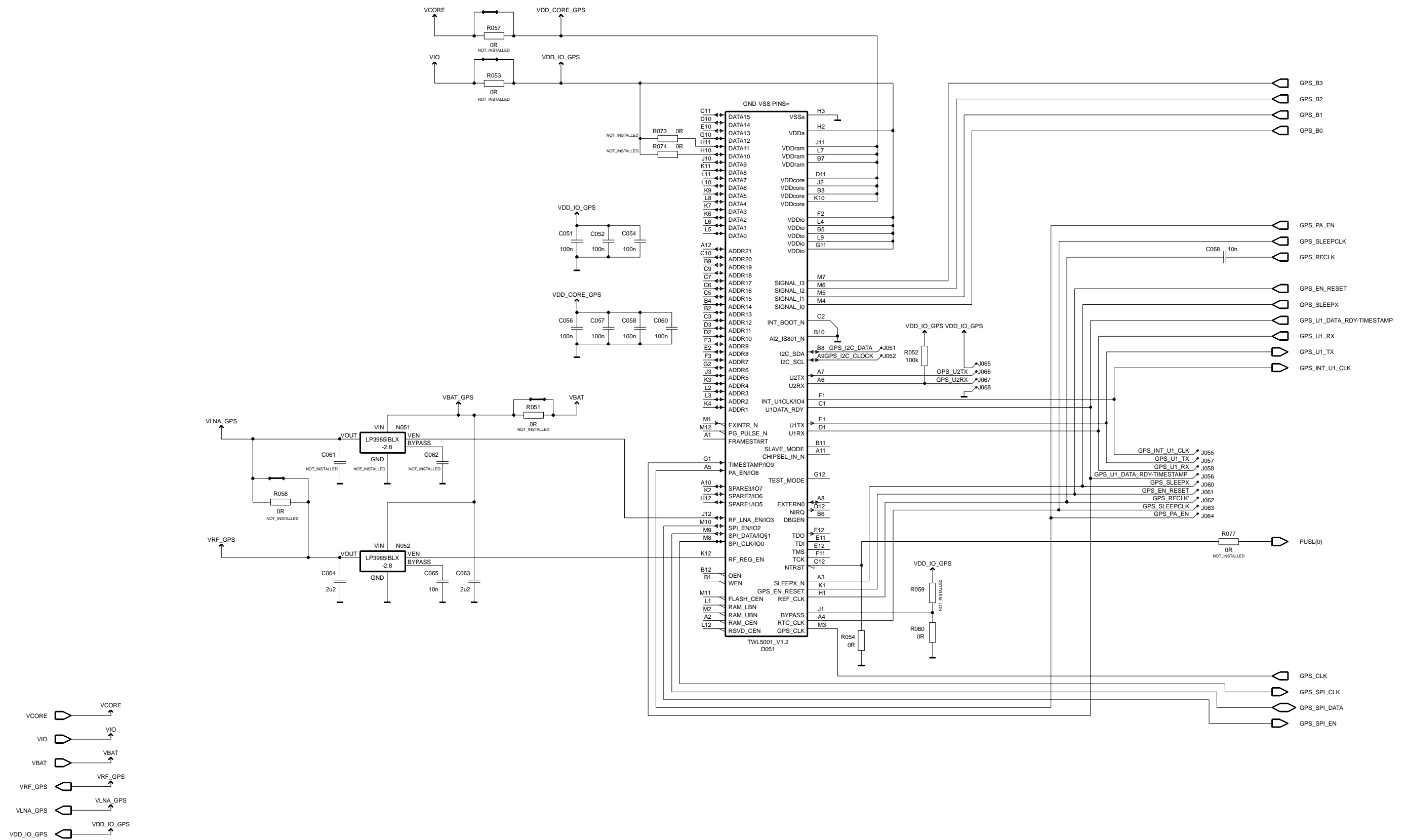

GPS RF-BB Interface

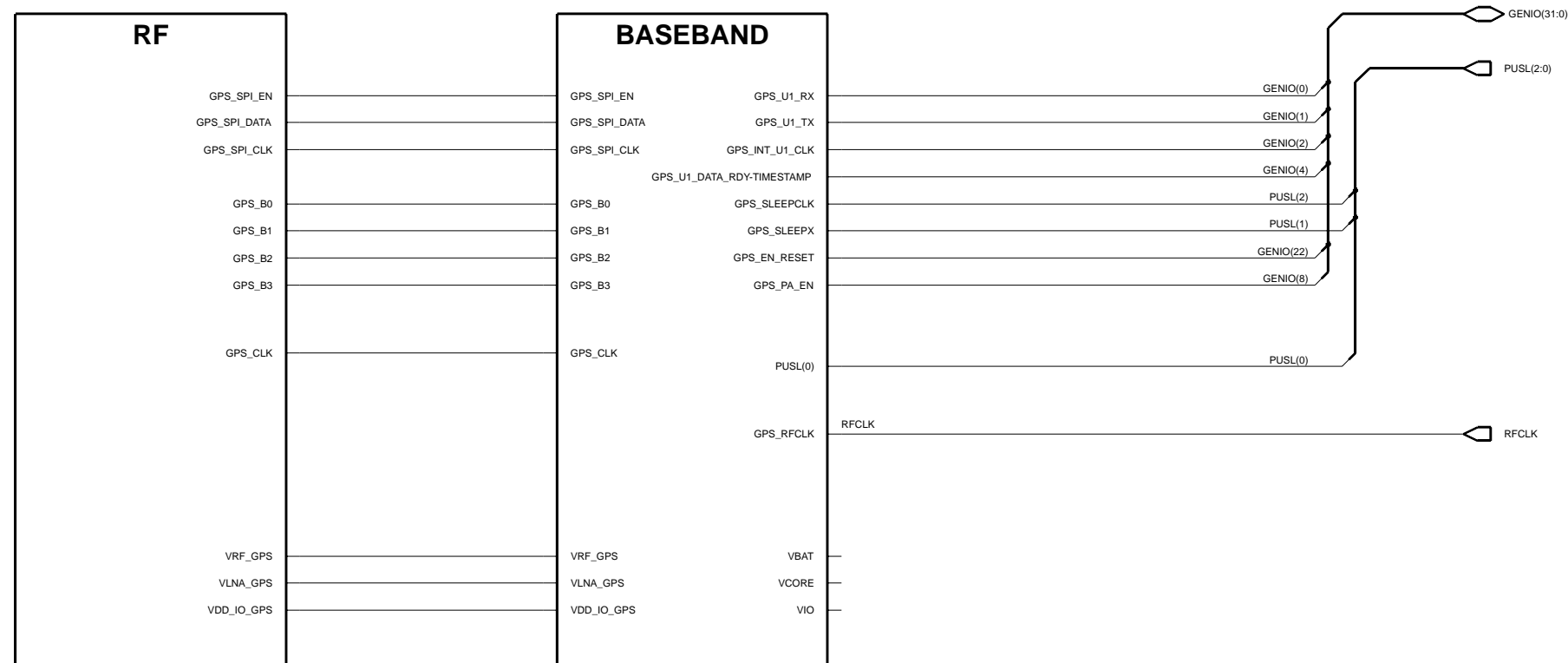

Circuit Diagram - UPP 8M

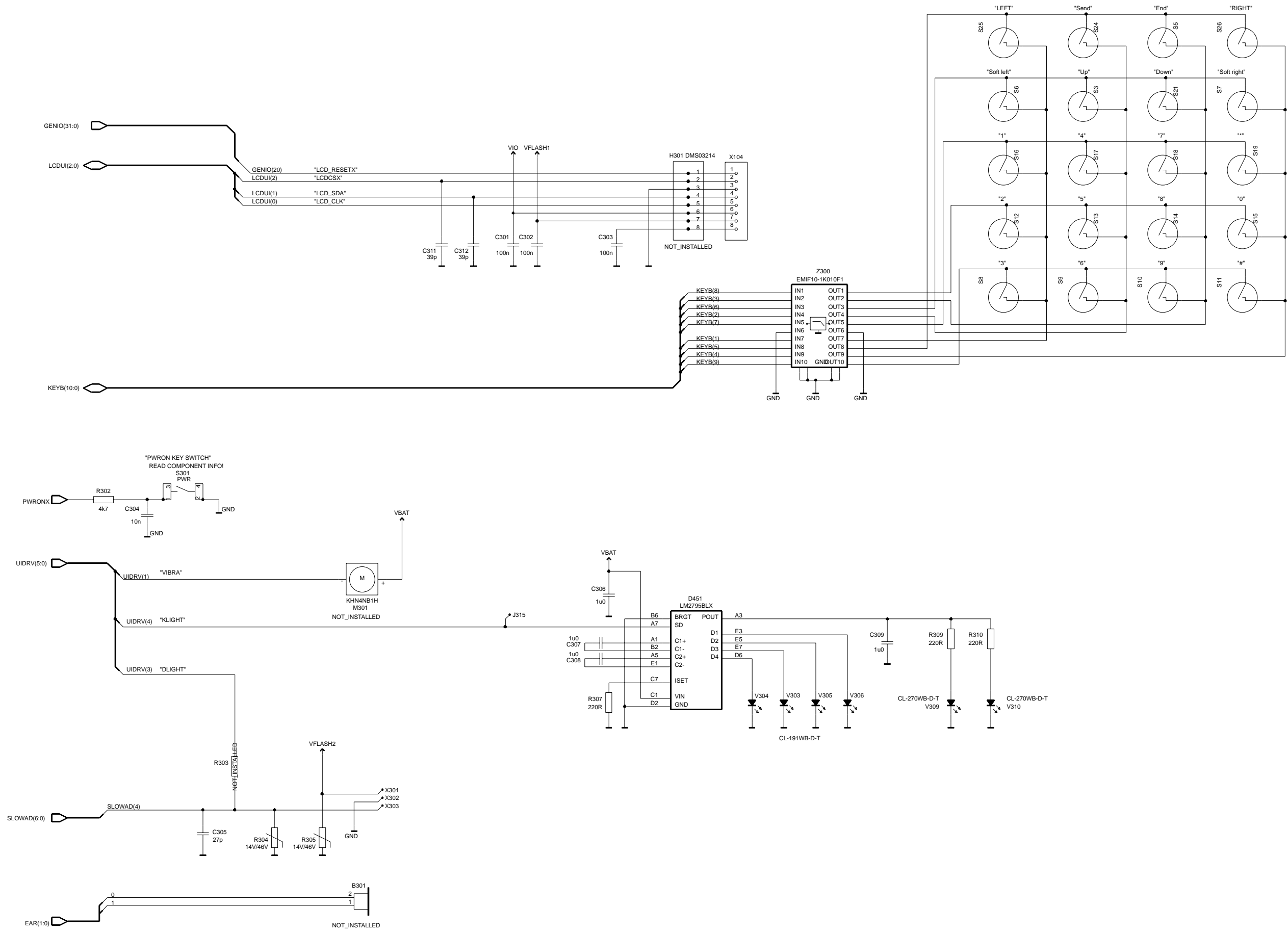

Circuit Diagram - User Interface

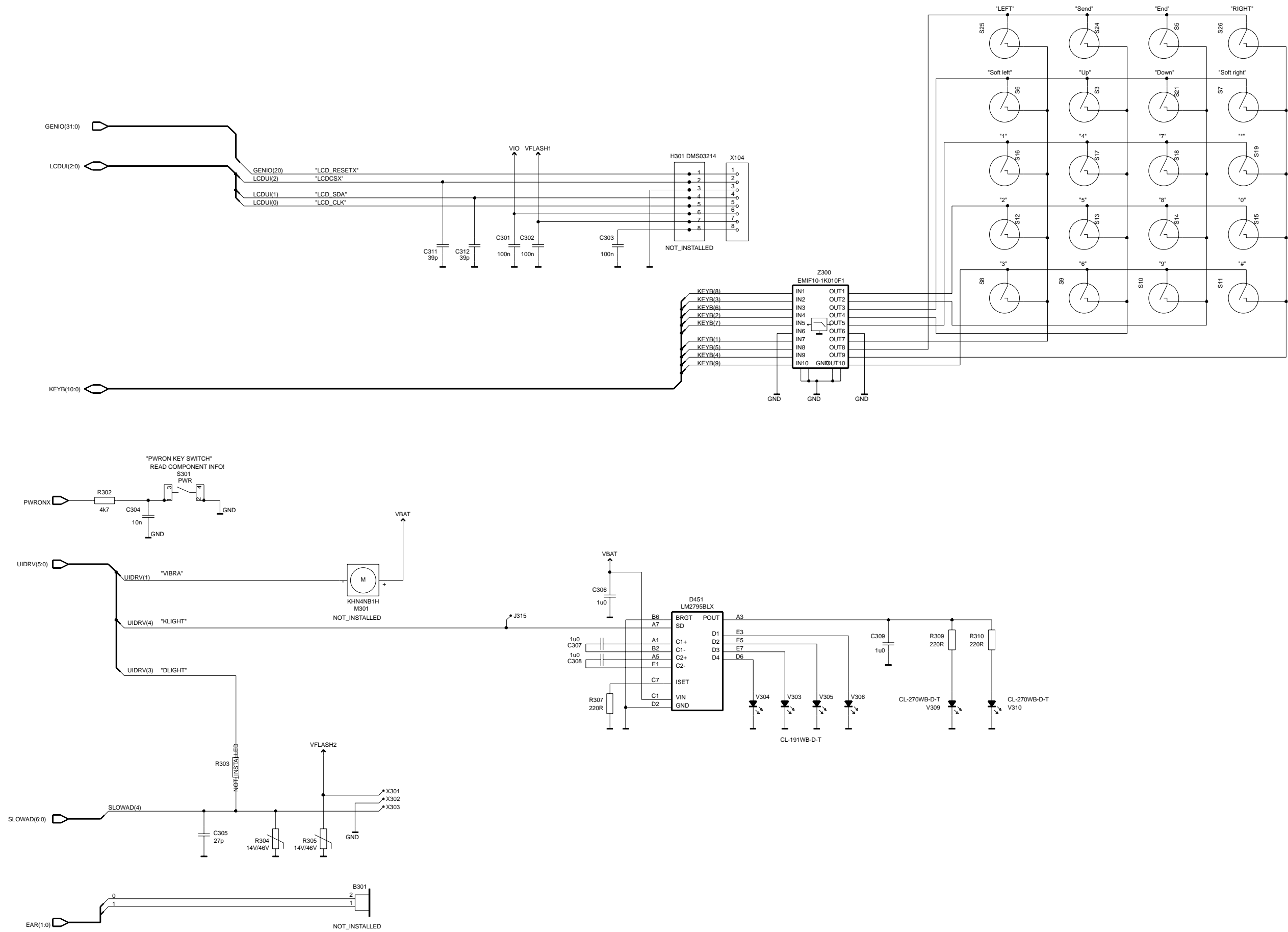

BB-RF Interface

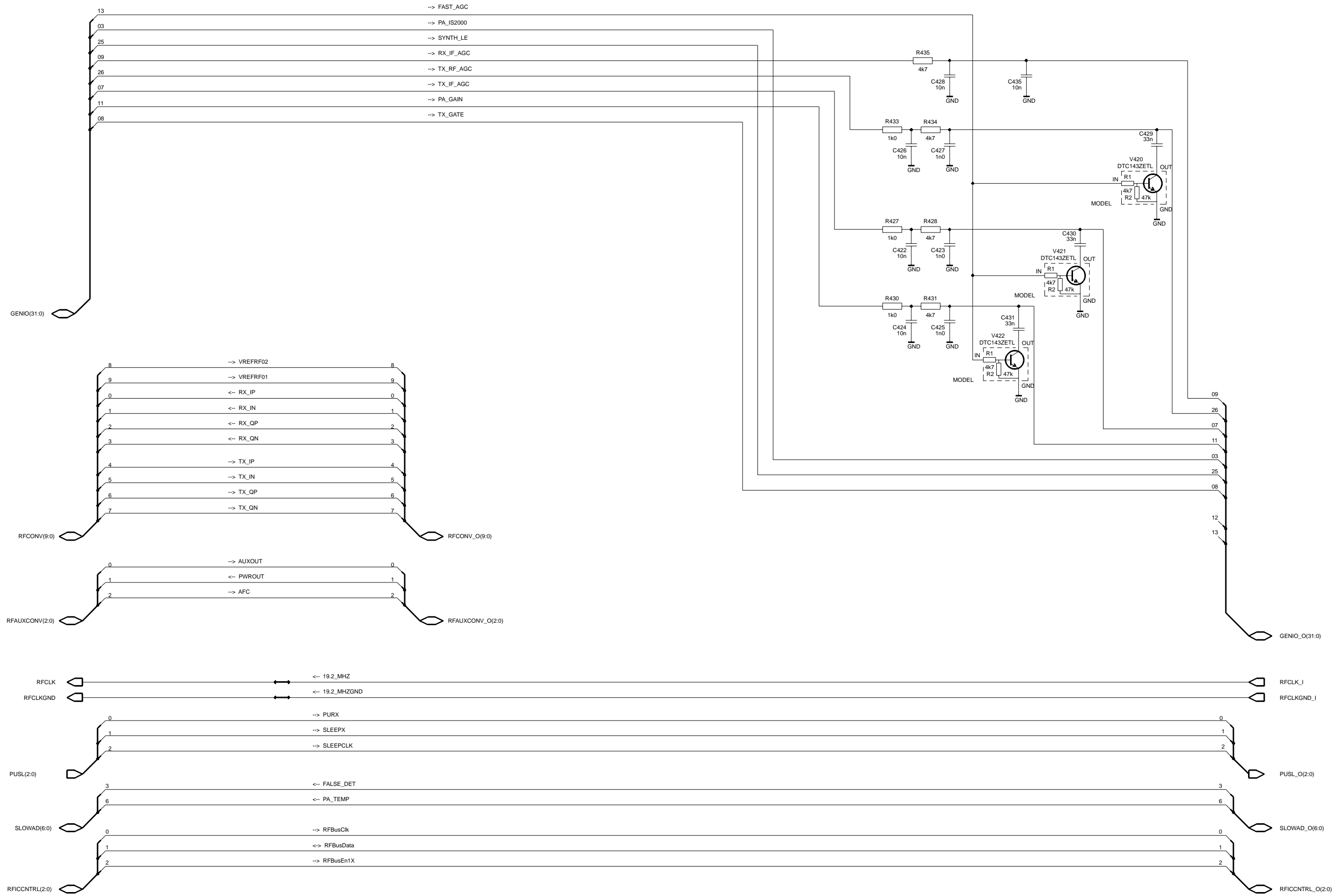

System Connector

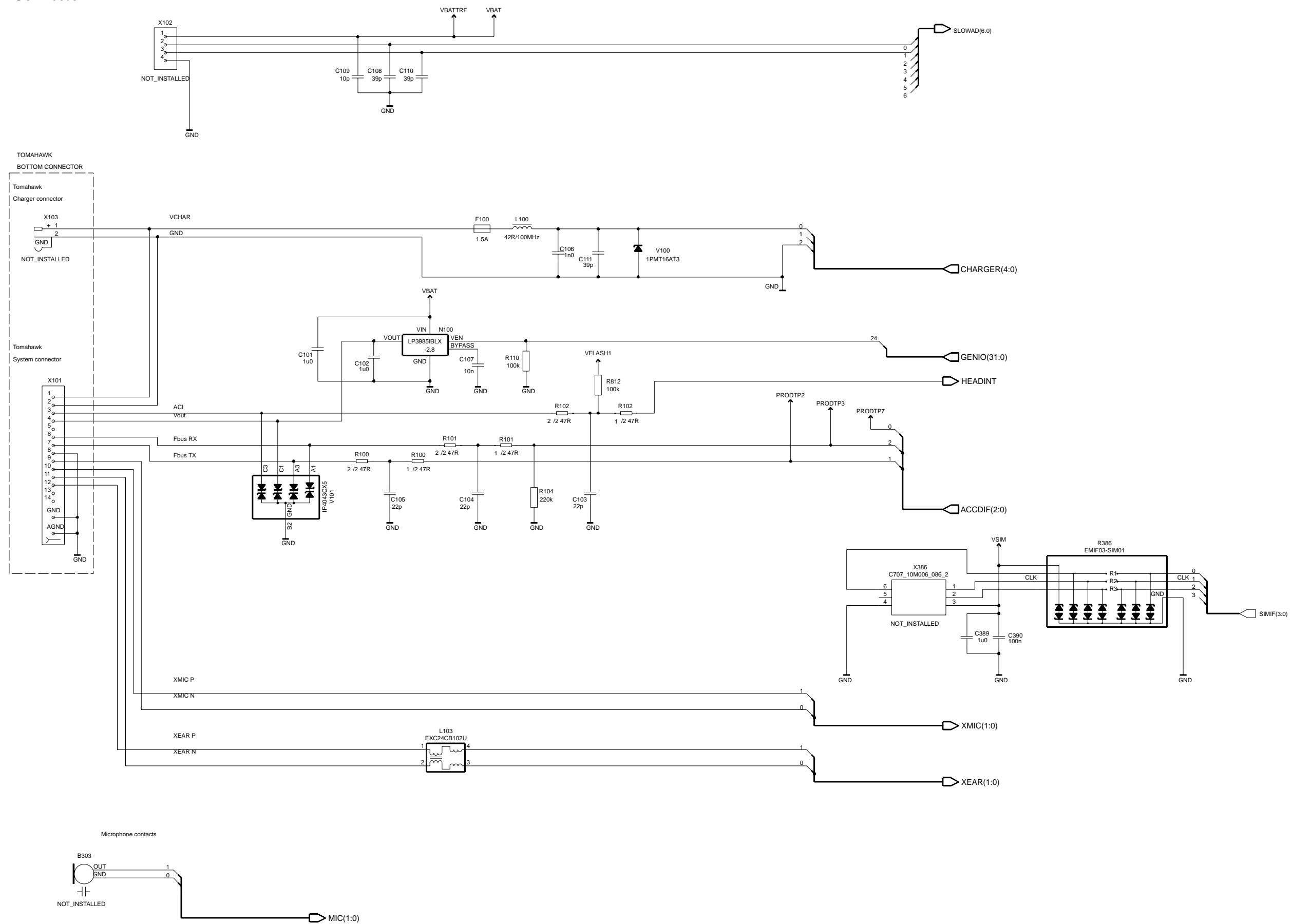

AMD 64 Mbit

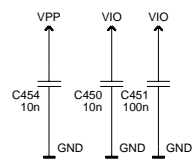
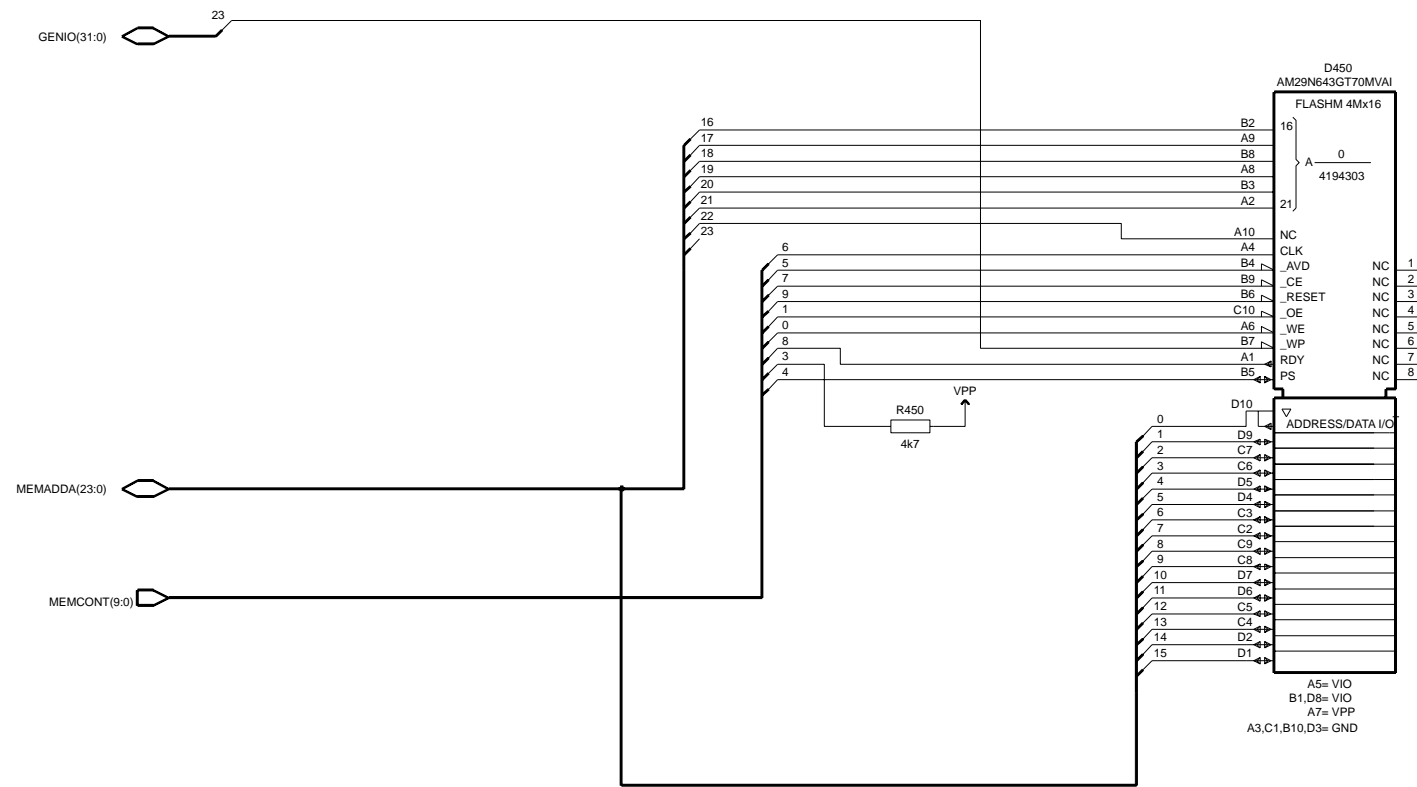

DCT4 Common Baseband - Top Level

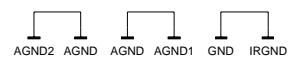
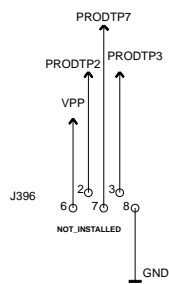
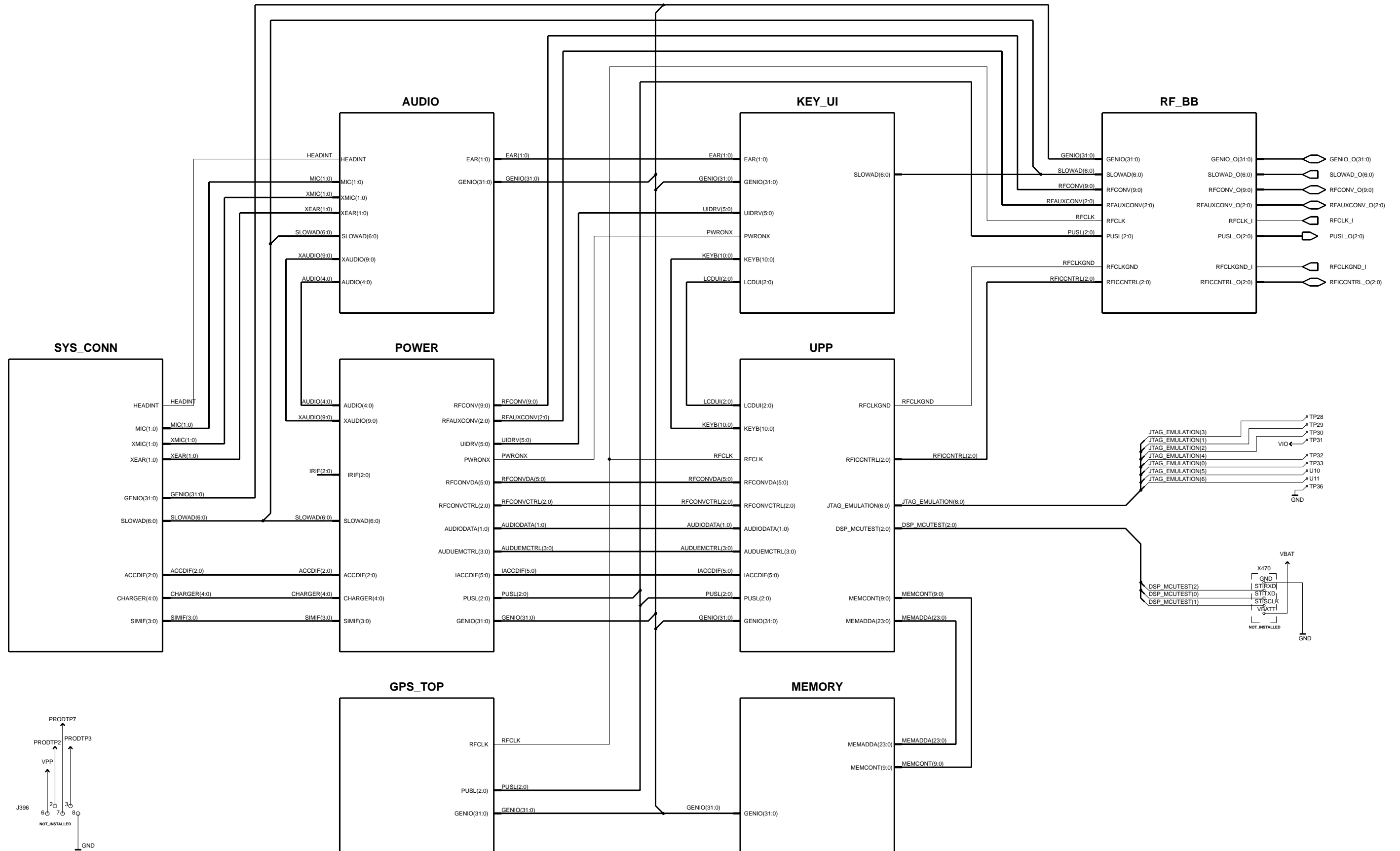

Circuit Diagram - Batman

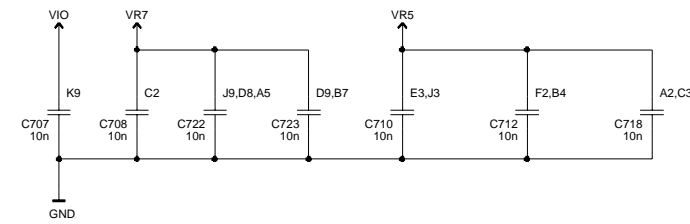
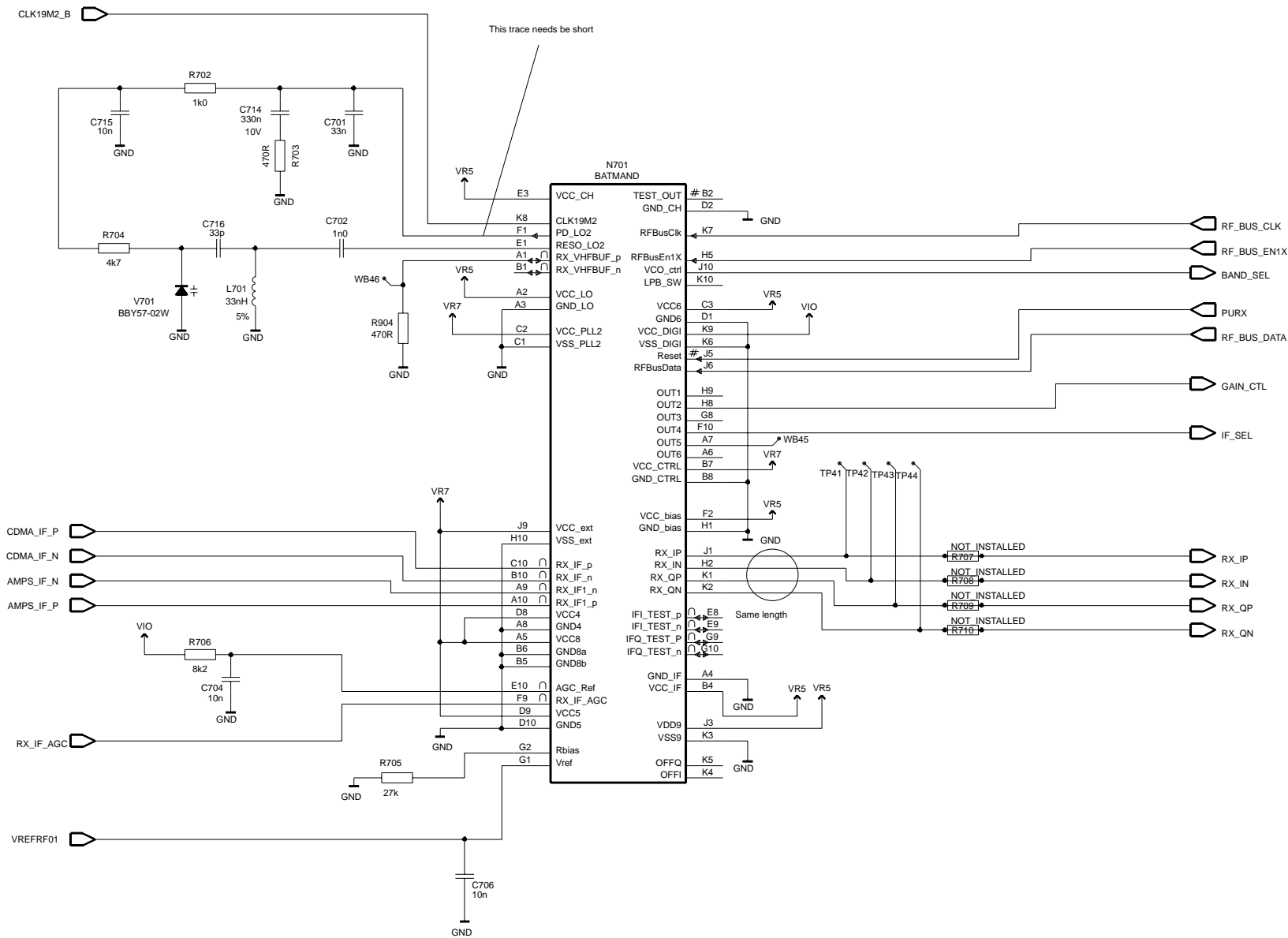

Circuit Diagram - UHF Synth

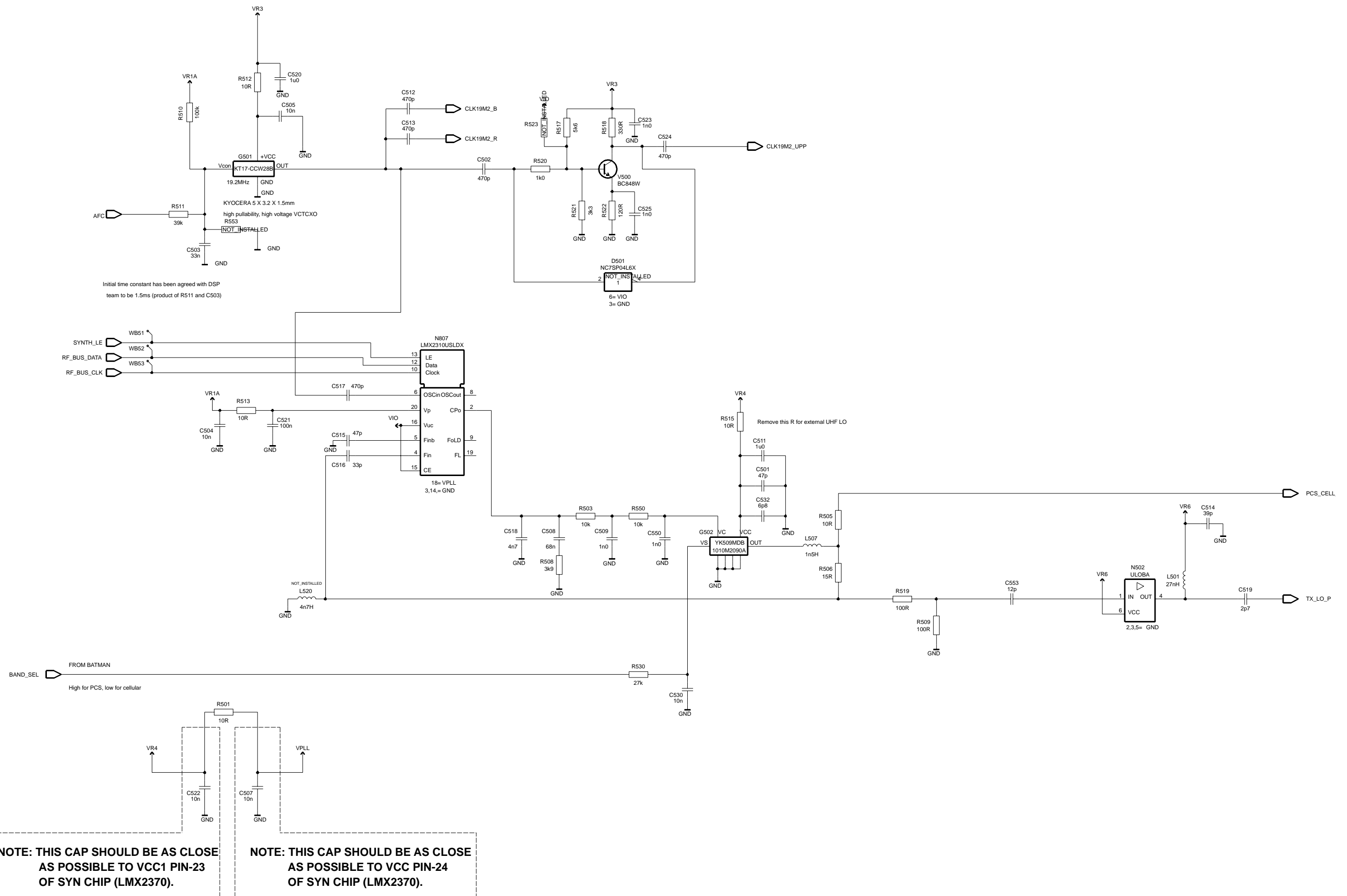

Circuit Diagram - Front End

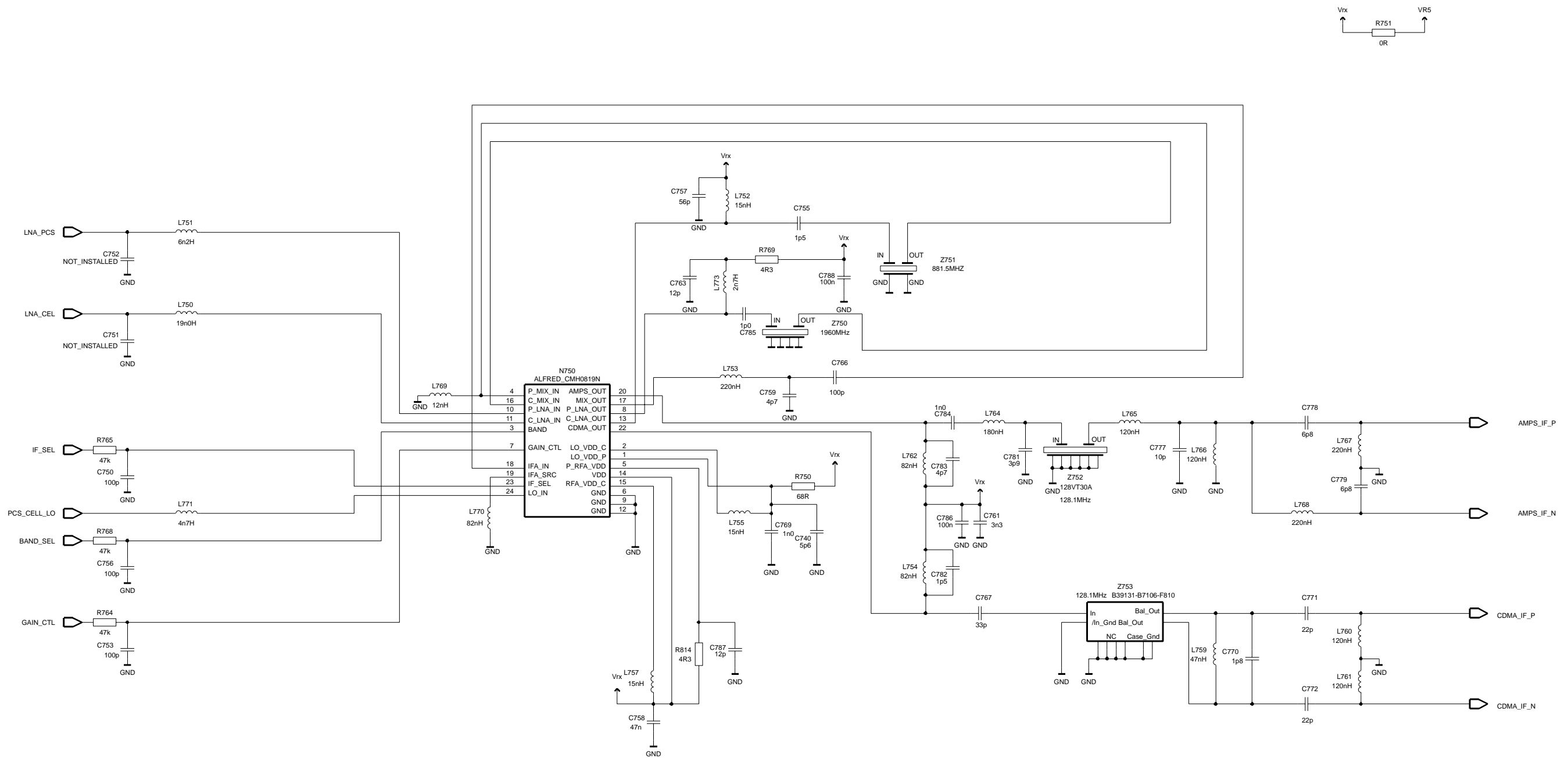

MODES	LOGIC INPUTS		
	BAND	GAIN_CTL	IF_SEL
CEL CDMA Hi Gain	0	1	0
CEL CDMA Lo Gain	0	0	0
PCS CDMA Hi Gain	1	1	0
PCS CDMA Lo Gain	1	0	0
AMPS Hi Gain	0	1	1
AMPS Lo Gain	0	0	1

Circuit Diagram - Robin

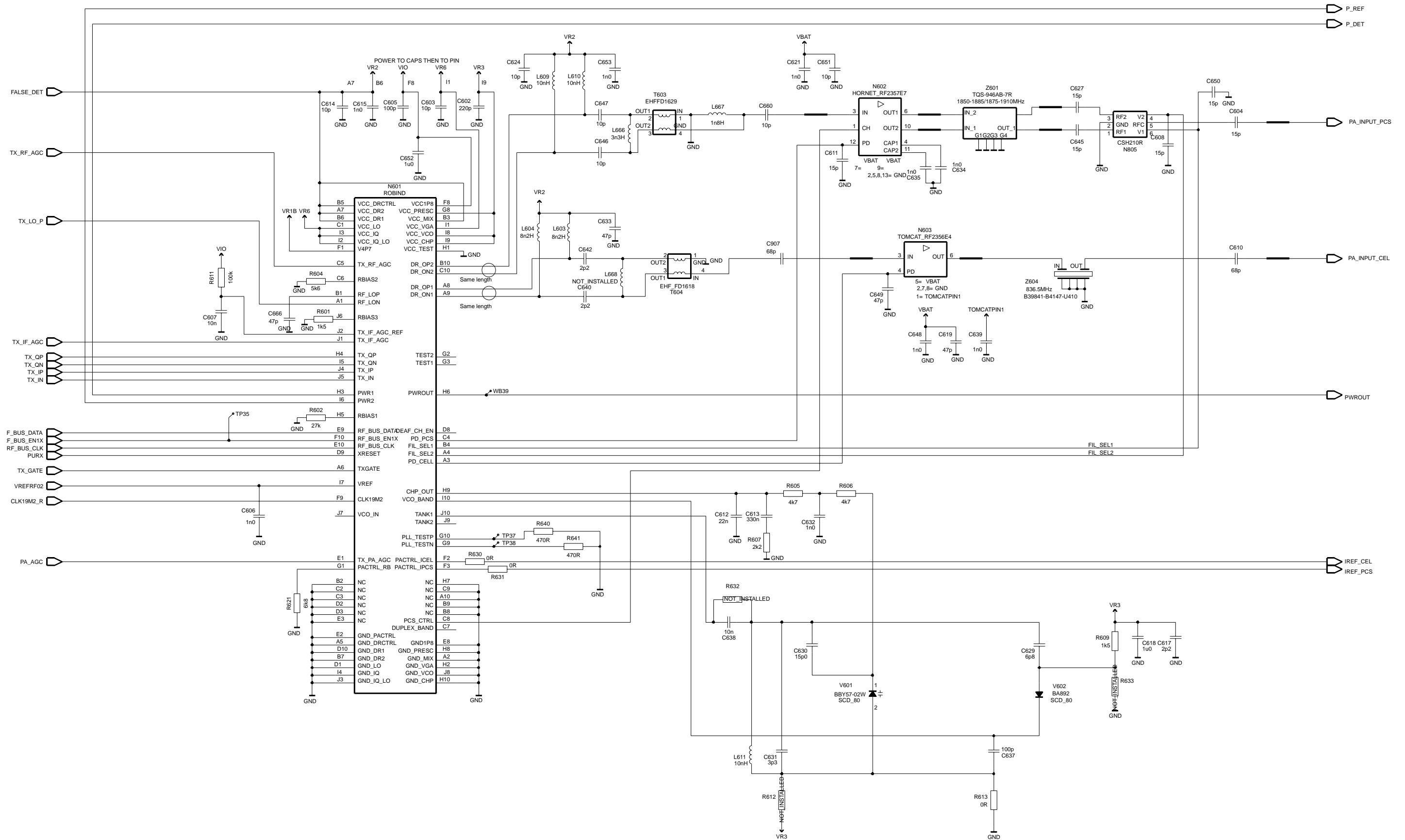

Circuit Diagram - PA

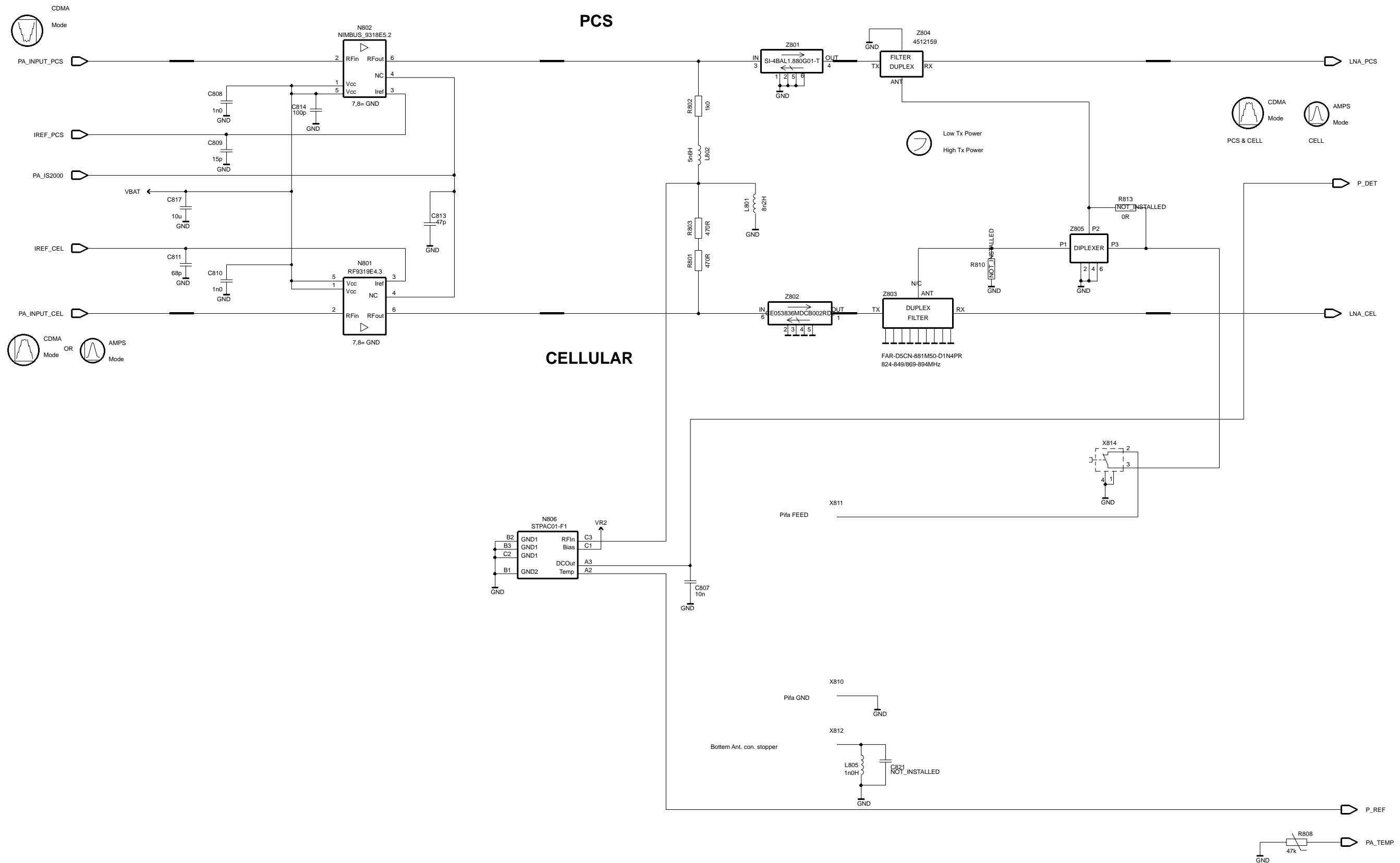

Circuit Diagram - Top Level

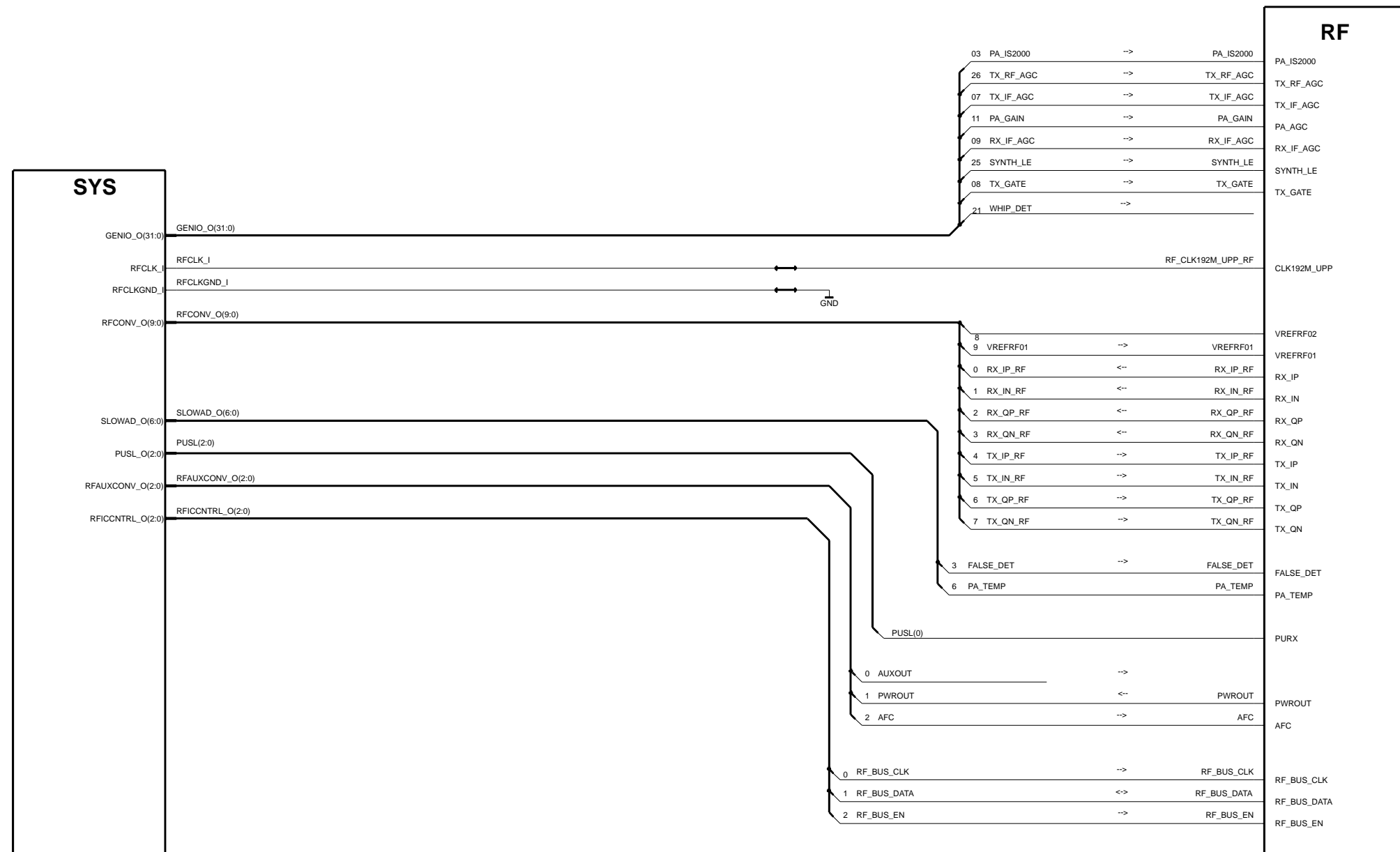

Shields

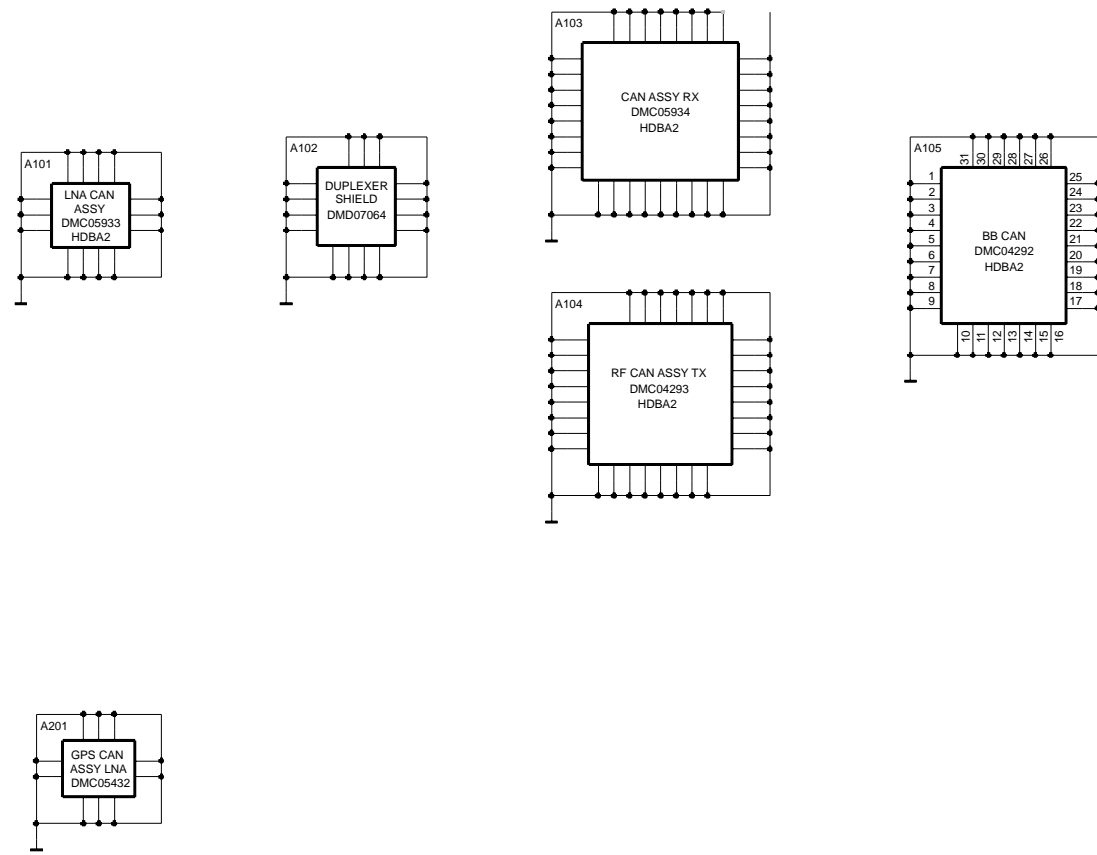

Component Layout (3585i)- Top

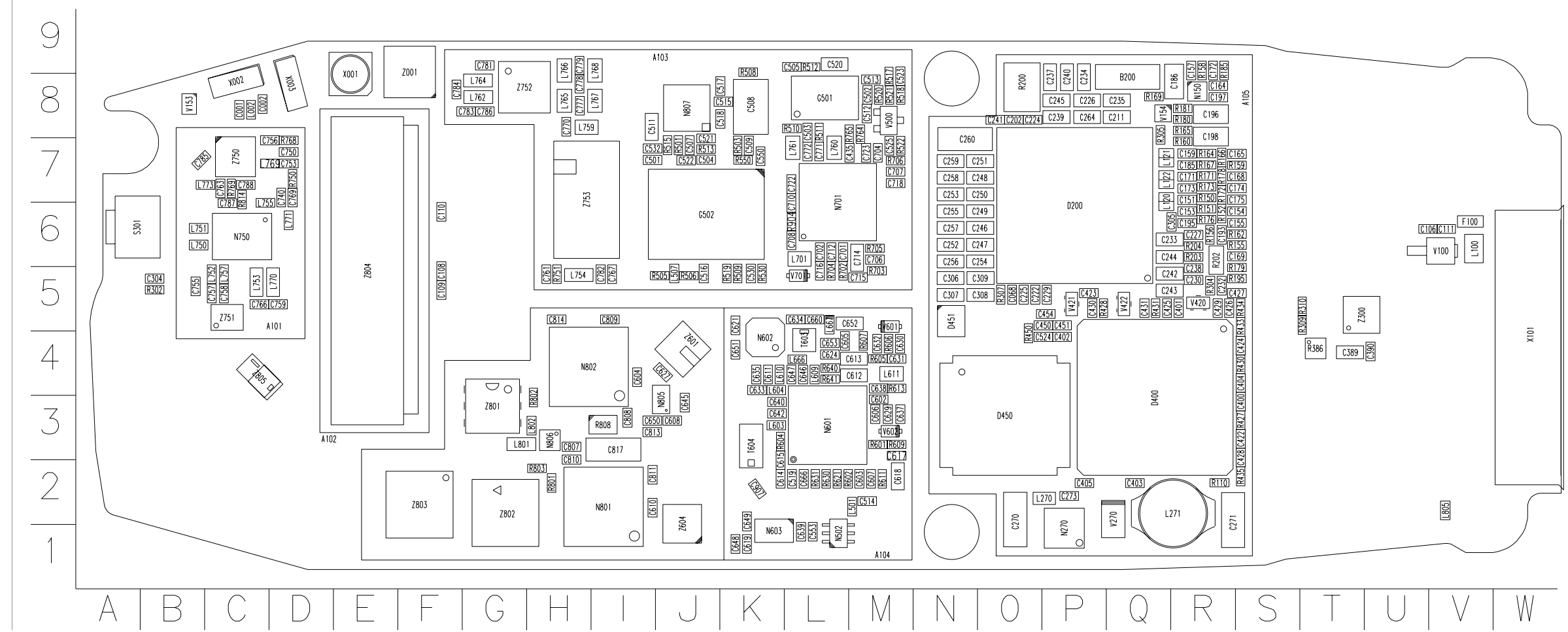

Component Layout (3585i) - Bottom

