

# YUHINA2&3 Block Diagram

Project code: 91.40I01.001  
 PCB P/N : 48.40I01.0SB  
 REVISION : 03245-2

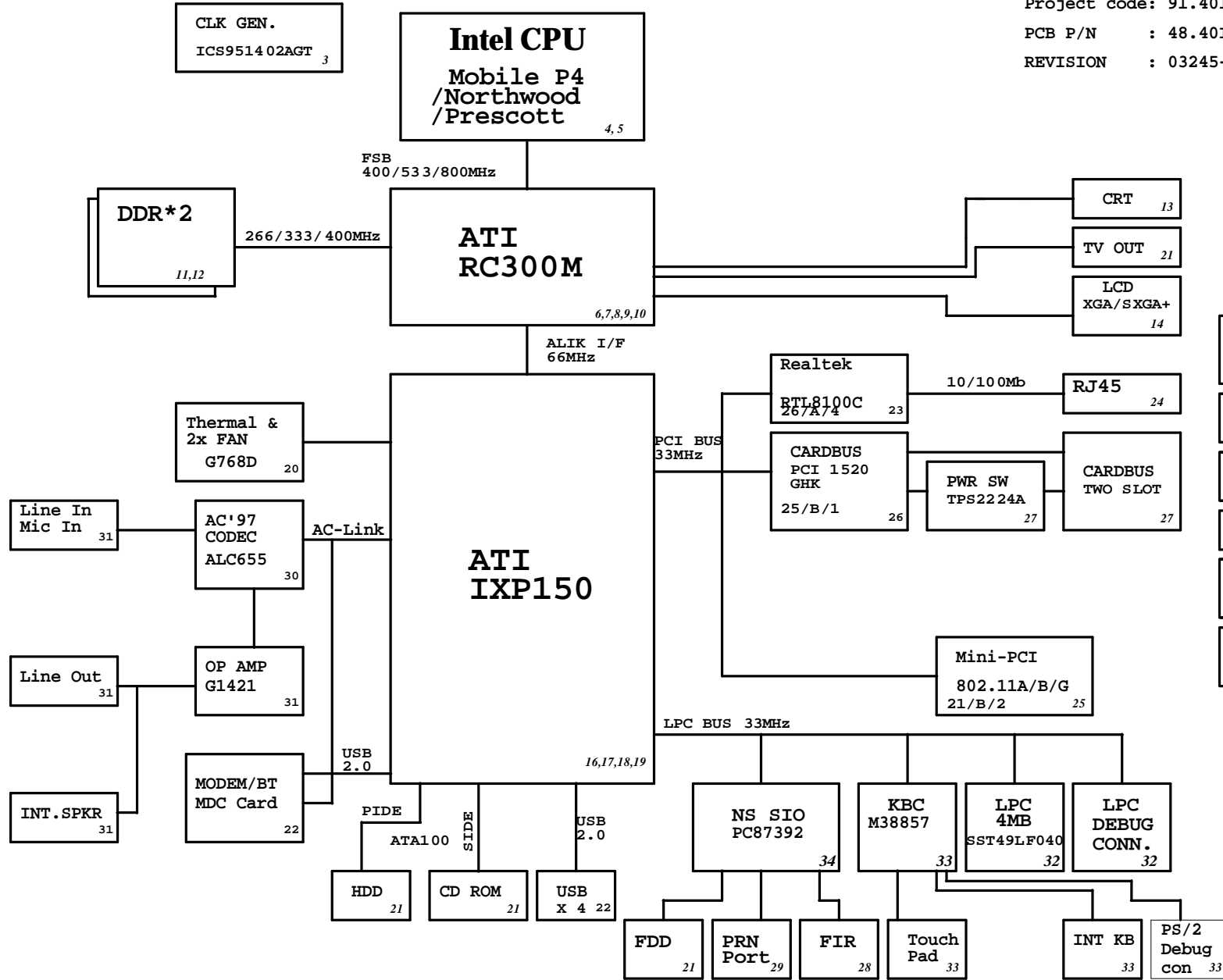

SYSTEM DC/DC TPS51020DBT 38	
INPUTS	OUTPUTS
DCBATOUT	5V_S5 5V_S3 5V_S0 3D3V_S5 3D3V_S3 3D3V_S0

SYSTEM DC/DC TPS5110 37	
INPUTS	OUTPUTS
DCBATOUT	2D5V_S5 1D5V_S0

APL5331 36	
INPUTS	OUTPUTS
2D5V_S3	1D25V_S0

CPU DC/DC MAX1546AETL 39,40 CM2843ACIM25 39	
INPUTS	OUTPUTS
DCBATOUT	+VCC_CORE 1.3V 44A +VID 1.2V 0.3A

MAXIM CHARGER MAX1909 41	
INPUTS	OUTPUTS
DCBATOUT	BT+ 1.8V 4.0A UP+5V 5V 10.0mA

PCB LAYER	
L1:	Signal 1
L2:	VCC/GND
L3:	Signal 2
L4:	Signal 3
L5:	GND
L6:	Signal 4

- Micro-P ATTINY12L-4SI 42
- BAT CONN 43
- AD CONN 43
- INVERTER 14
- Power Button 35
- EMI 45

**緯創資通 Wistron Corporation**  
 21F, 88, Sec. 1, Hsin Tai Wu Rd., Hsichih,  
 Taipei Hsien 221, Taiwan, R.O.C.

Title: **BLOCK DIAGRAM**

Size	Document Number	Rev
Custor	YUHINA2&3	-2

Date: Tuesday, March 23, 2004 Sheet 1 of 46

1D2V\_VID 1D2V\_VID 4,5,39  
 1D5V\_S0 1D5V\_S0 6,9,15,36,45  
  
 2D5V\_S0 2D5V\_S0 7,15,18,44,45  
 2D5V\_S3 2D5V\_S3 8,9,11,12,18,36,37,44,45  
  
 3D3V\_S0 3D3V\_S0 3,4,6,7,9,11,13,14,15,16,17,18,19,20,21,22,23,25,26,27,28,30,32,33,34,35,39,44,45,46  
 3D3V\_S3 3D3V\_S3 8,14,16,17,18,19,30,33,44,45  
 3D3V\_S5 3D3V\_S5 4,8,17,18,19,22,30,35,36,38,44,45  
  
 3D3V\_LAN\_S5 3D3V\_LAN\_S5 22,23,24,44  
  
 5V\_USB1\_S0 5V\_USB1\_S0 22  
 5V\_USB3\_S0 5V\_USB3\_S0 22  
  
 5V\_CRT\_S0 5V\_CRT\_S0 13  
 5VA\_AUD\_S0 5VA\_AUD\_S0 30,31,46  
 5V\_S0 5V\_S0 6,9,13,14,15,18,20,21,22,25,27,29,30,31,32,33,34,36,39,40,42,44,45  
  
 5V\_S5 5V\_S5 15,37,38,42,44  
 +5V\_UP\_S5 +5V\_UP\_S5 14,42,45  
 5V\_AUX\_S5 5V\_AUX\_S5 16,20,35,38,39,41,42,43,45,46  
  
 LCDVDD LCDVDD 14  
 AD+ AD+ 41,43,45  
  
 DCBATOUT DCBATOUT 14,15,18,20,35,37,38,40,41,42,44,45,46  
  
 VCC\_FAN VCC\_FAN 20  
 A\_SKT\_VCC\_S0 A\_SKT\_VCC\_S0 26,27  
 A\_SKT\_VPP\_S0 A\_SKT\_VPP\_S0 27

**PCI DEVICE RESOURCE ASSIGNMENT**

	BUS	DEVICE	IDSEL	PCI_REQ#	PCI_GNT#	INT_IRQ#
LAN	1	5	PCI_AD26	REQ#4	GNT#4	IRQD#
CardBus	1	9	PCI_AD20	REQ#1	GNT#1	IRQB# / IRQA#
MiniPCI	1	6	PCI_AD21	REQ#2	GNT#2	IRQE#

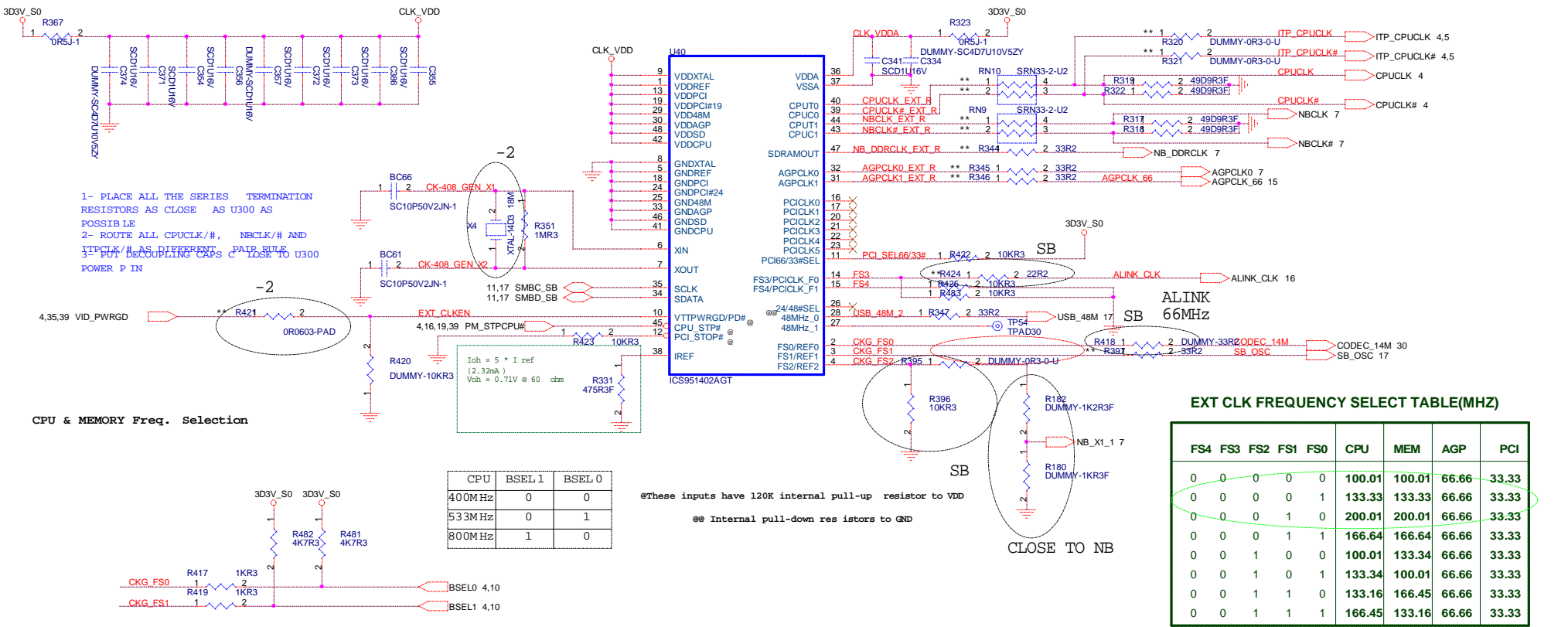

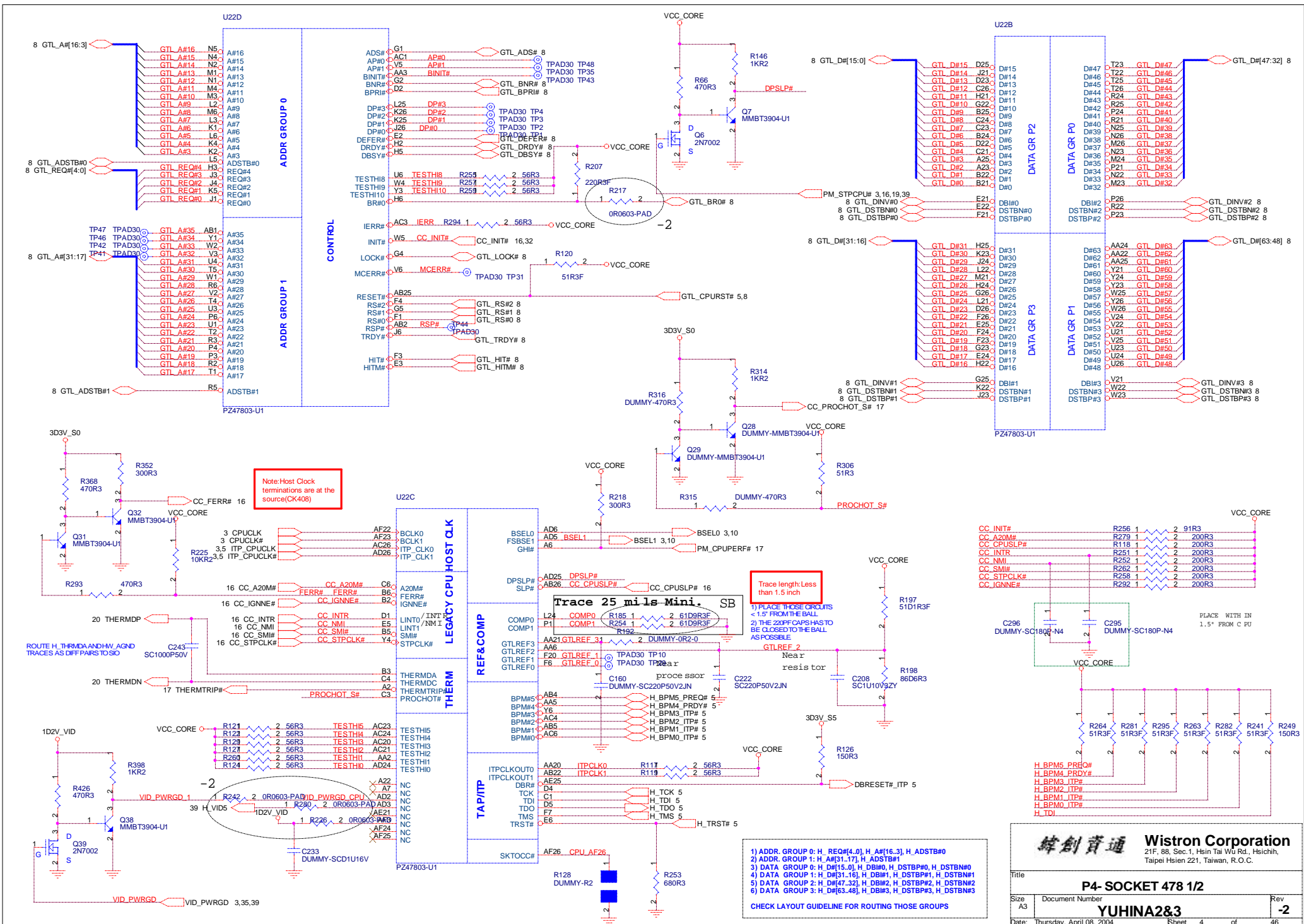

Note: Host Clock terminations are at the source (CK408)

Trace length: Less than 1.5 inch

- 1) ADDR. GROUP 0: H\_REQ#(4..0), H\_A#(16..3), H\_ADSTB#0
  - 2) ADDR. GROUP 1: H\_A#(31..17), H\_ADSTB#1
  - 3) DATA. GROUP 0: H\_D#(15..0), H\_DB#0, H\_DSTB#0, H\_DSTBN#0
  - 4) DATA. GROUP 1: H\_D#(31..16), H\_DB#1, H\_DSTB#1, H\_DSTBN#1
  - 5) DATA. GROUP 2: H\_D#(47..32), H\_DB#2, H\_DSTB#2, H\_DSTBN#2
  - 6) DATA. GROUP 3: H\_D#(63..48), H\_DB#3, H\_DSTB#3, H\_DSTBN#3
- CHECK LAYOUT GUIDELINE FOR ROUTING THOSE GROUPS

**Wistron Corporation**  
 21F, 88, Sec. 1, Hsin Tai Wu Rd., Hsichih,  
 Taipei Hsien 221, Taiwan, R.O.C.

<b>P4-SOCKET 478 1/2</b>		
Title	Document Number	Rev
<b>YUHINA2&amp;3</b>		<b>-2</b>
Date: Thursday, April 08, 2004	Sheet 4 of 46	

**Layout Note:**  
 C3D7 should be placed within 600 mils of the VCCA and VSSA pins  
 VCCA should be routed in parallel and next to VSSA

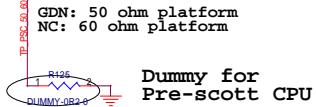
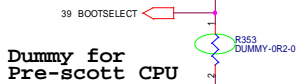
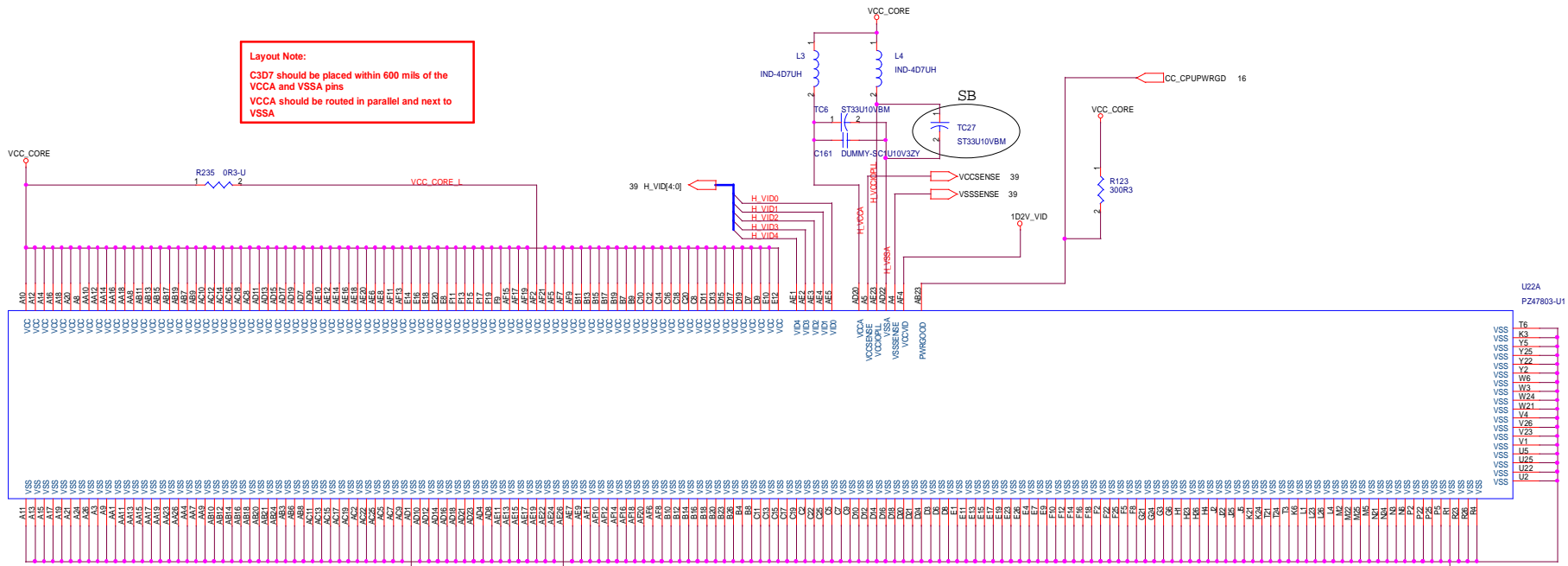

**10U/X5R 1206 DECOUPLING CAPS  
 8X IN SOCKET CAVITY  
 10X IN CRB**

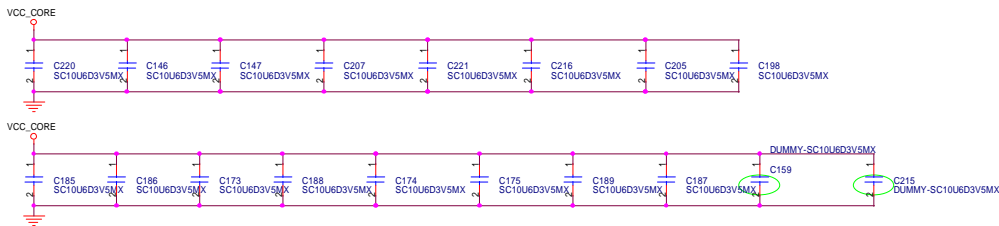

**ITP Debug Pad**

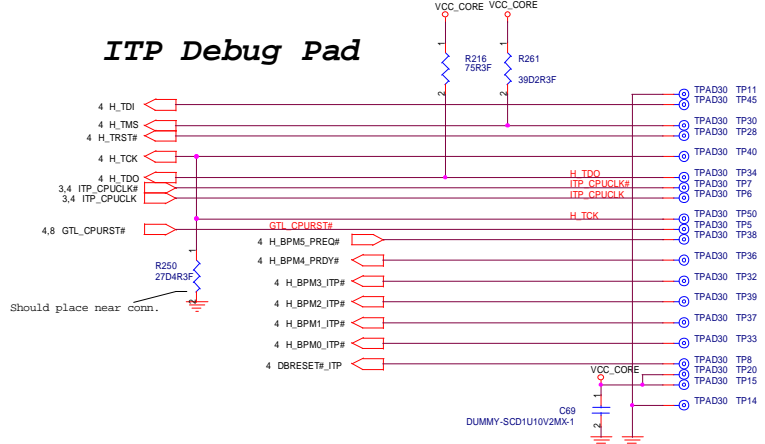

**緯創資通 Wistron Corporation**  
 21F, 88, Sec.1, Hsin Tai Wu Rd., Hsichih,  
 Taipei Hsien 221, Taiwan, R.O.C.

Title			P4- SOCKET 478 2/2		
Size	Document Number	Rev			
Custom	YUHINA2&3	-2			
Date:	Thursday, April 08, 2004	Sheet	5	of	46

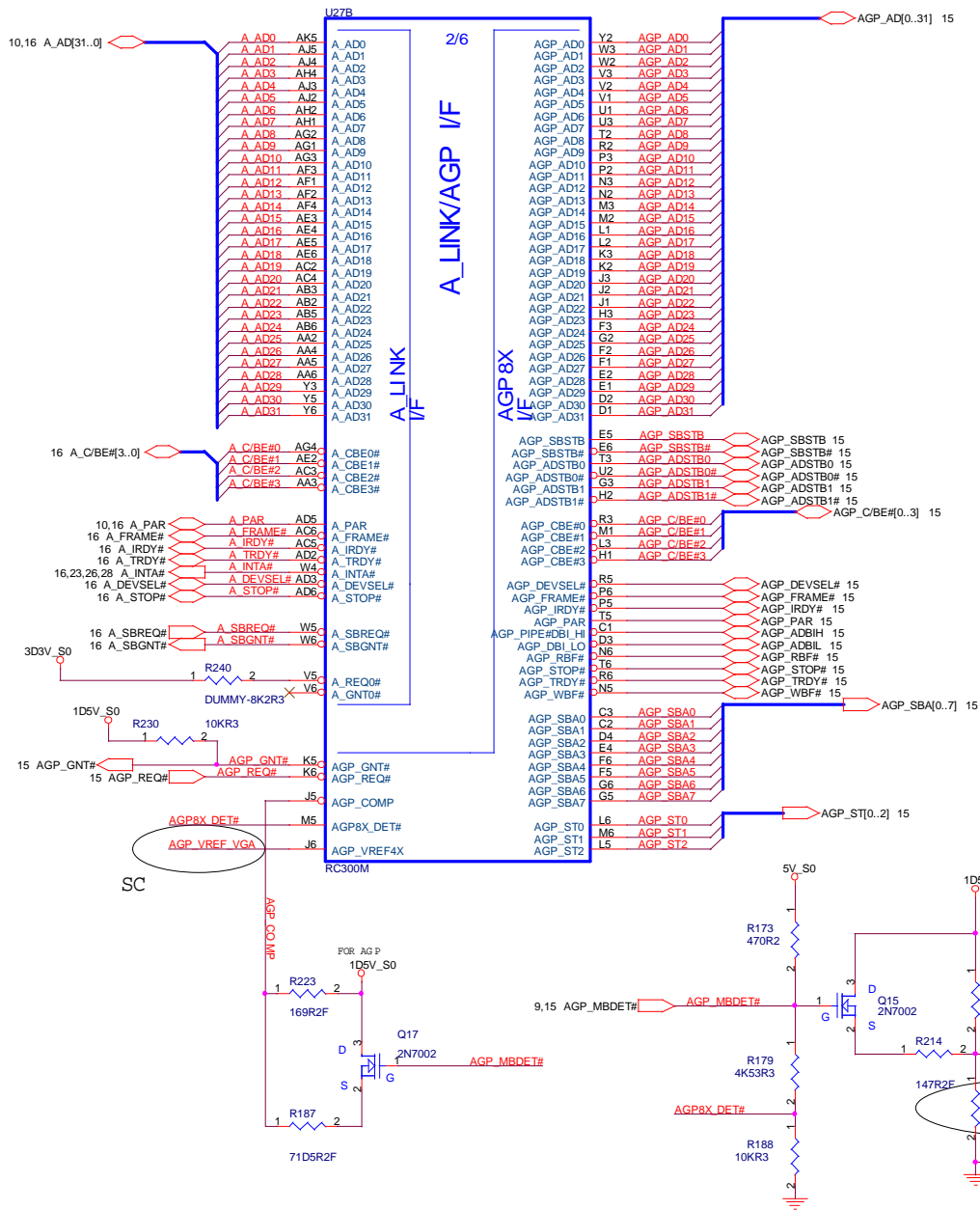

AVDD	DAC VDD	(2.5V)
AVDDI	DIGITAL V DD	(1.8V)
AVDDQ	DAC2 BANDGAP REF	(1.8V)
PLLVD	PLL VDD	(1.8V)

PUT AVDD, AVDDI, AV DDQ, PLVDD  
DECOUPLING CAPS ON THE  
BOTTOM, CLOSE T O BALLS

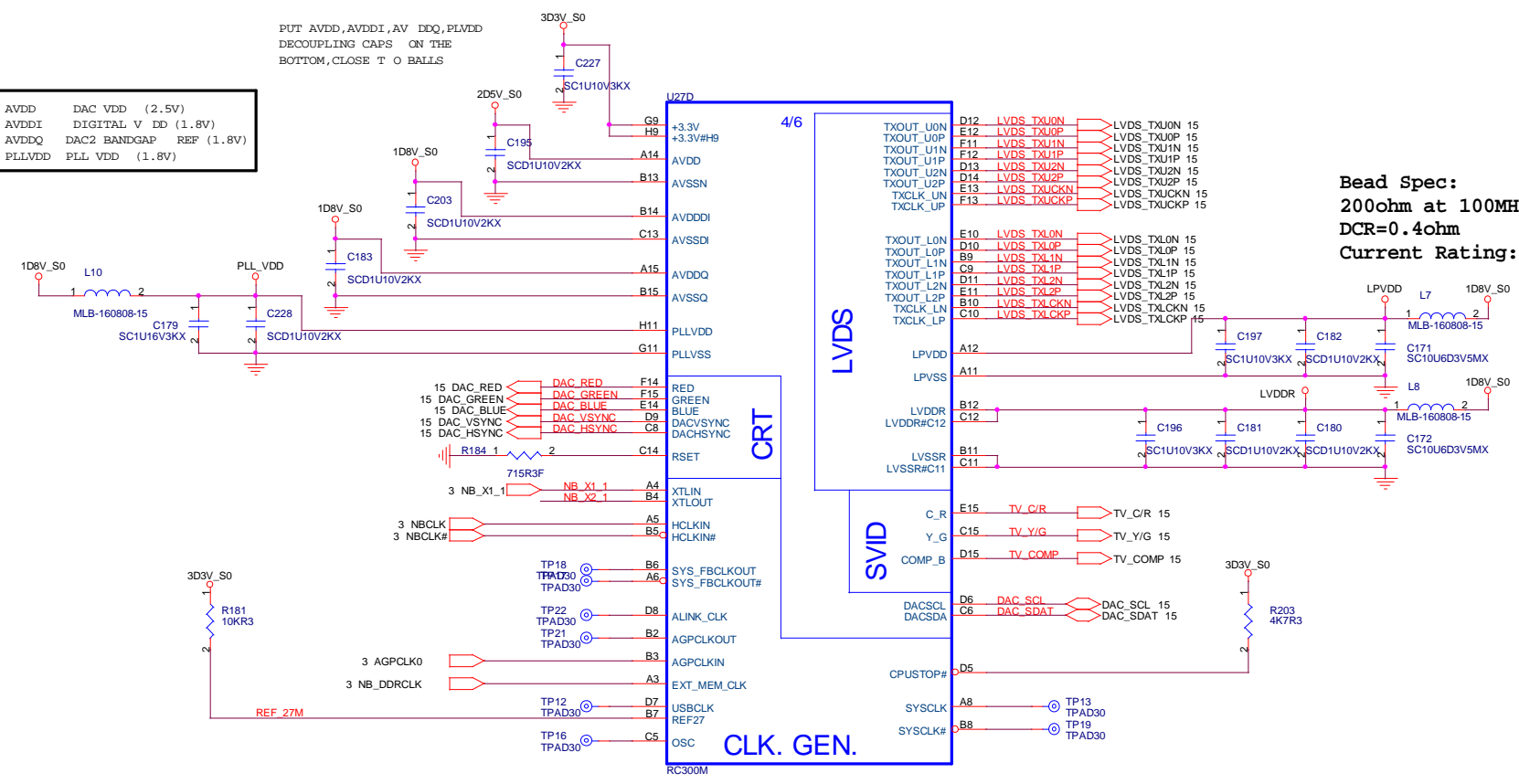

**Bead Spec:**  
**200ohm at 100MHZ**  
**DCR=0.4ohm**  
**Current Rating: 200mA**

15 DAC\_RED DAC RED F14  
 15 DAC\_GREEN DAC GREEN F15  
 15 DAC\_BLUE DAC BLUE E14  
 15 DAC\_VSYNC DAC VSYNC D9  
 15 DAC\_HSYNC DAC HSYNC C8

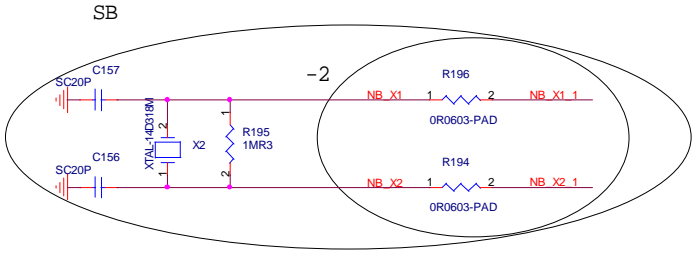

### GTL Command

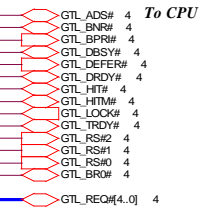

### GTL Data To CPU

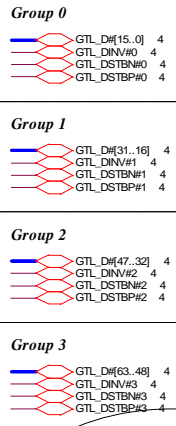

### GTL Address

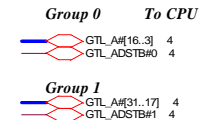

### CPU Reset To CPU

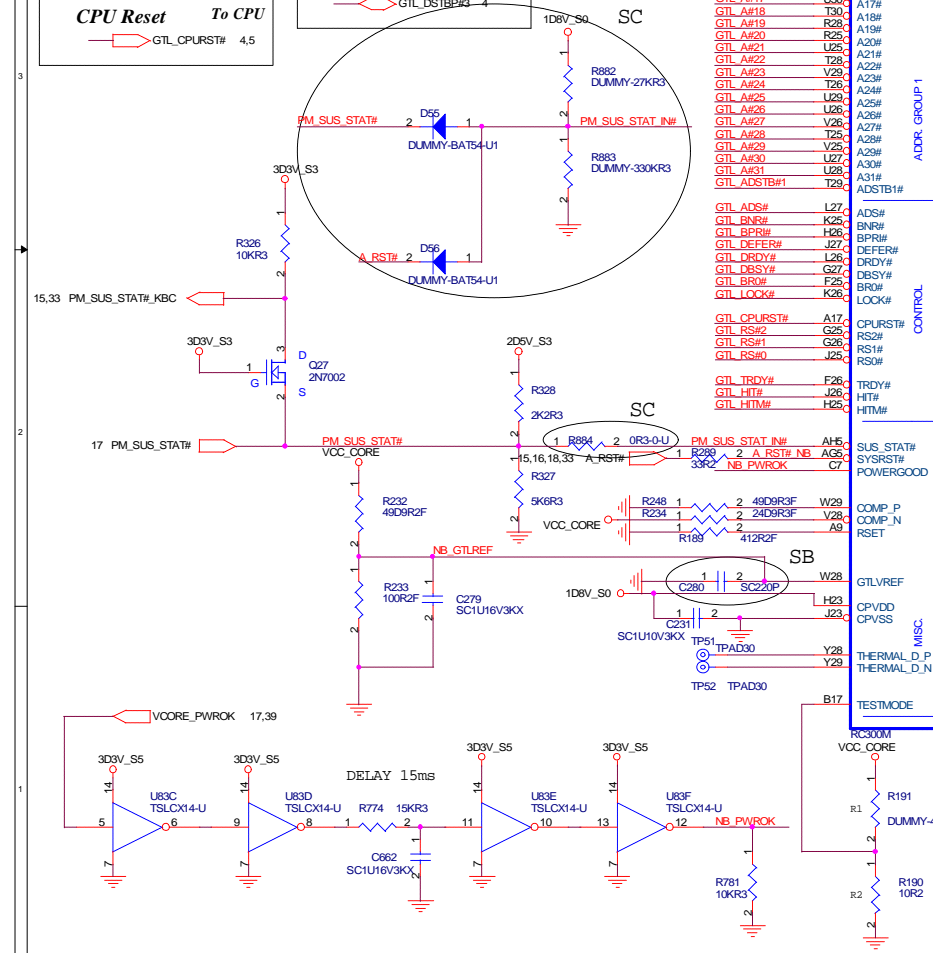

RESISTOR	RC300M MODE
R1	TEST MODE
R2	NORMAL MODE

**緯創資通 Wistron Corporation**  
21F, 88, Sec. 1, Hsin Tai Wu Rd., Hsichih, Taipei Hsien 221, Taiwan, R.O.C.

ATI RC300M (2/3)

YUHINA283

Date: Thursday, April 08, 2004

Sheet 8 of 46



CLOSE TO NB

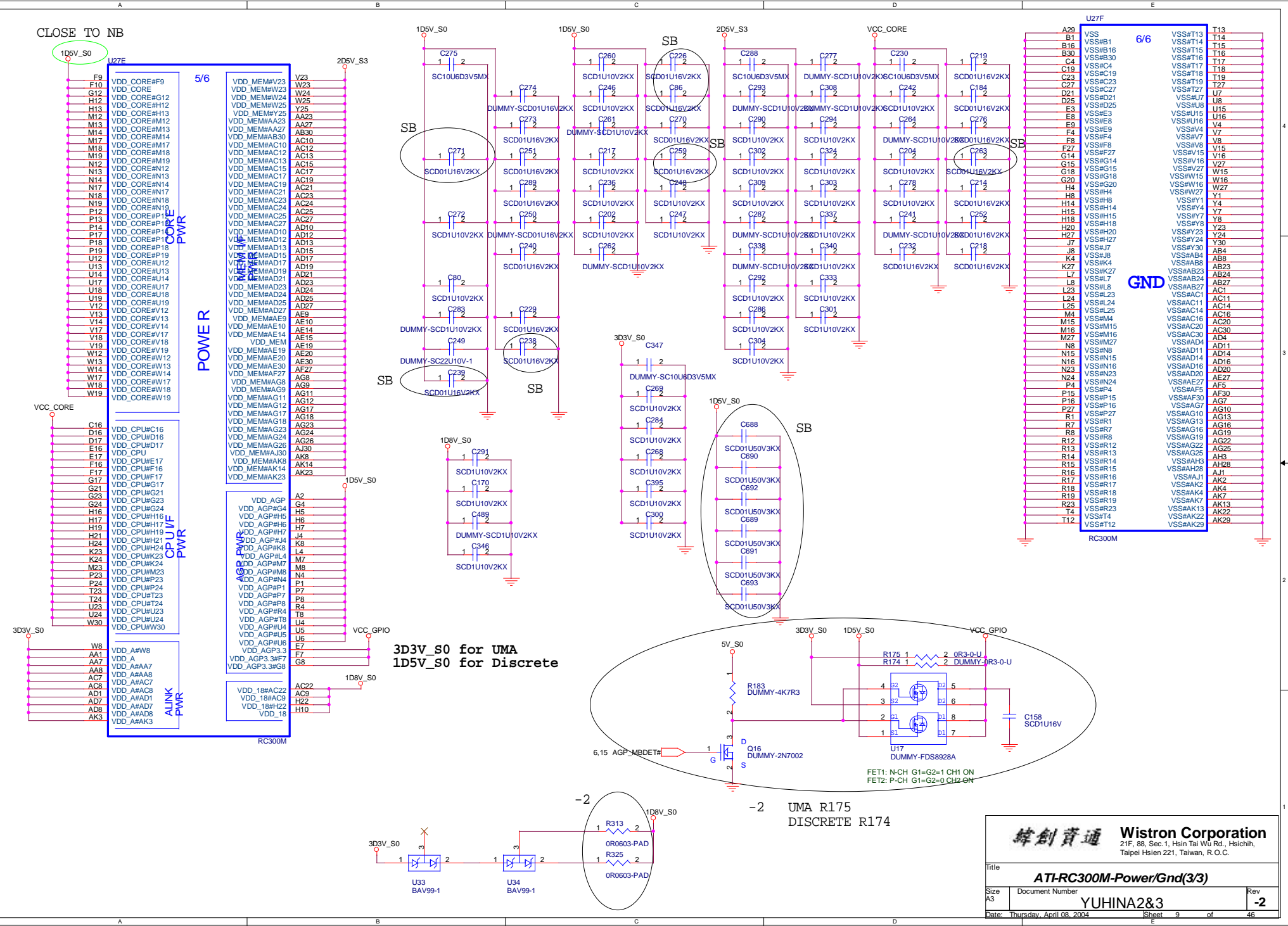

5/6

CORE PWR

POWER

CP U/I/F PWR

ALIGN PWR

6/6

GND

3D3V\_S0 for UMA  
1D5V\_S0 for Discrete

UMA R175  
DISCRETE R174

**緯創資通 Wistron Corporation**  
21F, 88, Sec. 1, Hsin Tai Wu Rd., Heichih, Taipei Hsien 221, Taiwan, R.O.C.

Title: **ATI-RC300M-Power/Gnd(3/3)**

Size A3 Document Number **YUHINA2&3** Rev **-2**

Date: Thursday, April 08, 2004 Sheet 9 of 46

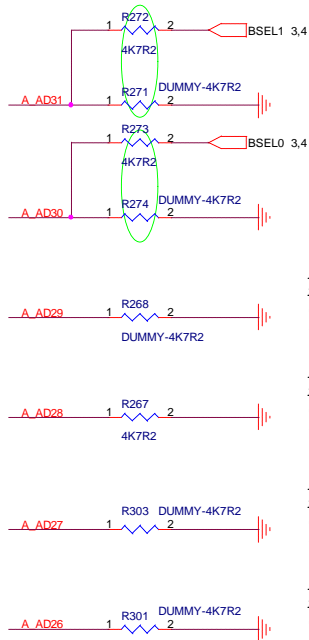

**A\_AD[31..30] : FSB CLK SPEED**  
 Default : 00  
 00: 100MHZ  
 01: 133MHZ  
 10: 200MHZ  
 11: 166MHZ

**A\_AD29 : STRAP CONFIGURATION**  
 Default : 1  
 0: REDUCED SET  
 1: FULL SET

**A\_AD28 : SPREAD SPECTRUM ENABLE**  
 Default : 0  
 0: DISABLE SS  
 1: ENABLE SS

**A\_AD27 : FrcShortTReset#**  
 Default : 1  
 0: TESTE MODE  
 1: NORMAL MODE

**A\_AD26 : ENABLE IOQ**  
 Default : 1  
 0: IOQ=1  
 1: IOQ=12

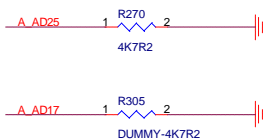

**A\_AD25,A\_AD17 : CPU VOLTAGE[1..0]**  
 Default : 01  
 00: 1.05V (MOBILE CPU)  
 01: 1.35V (MOBILE CPU)  
 10: 1.45V (DESKTOP CPU)  
 11: 1.75V (DESKTOP CPU)



**A\_AD24 : MOBILE CPU SELECT**  
 Default : 1  
 0: BANIAS CPU  
 1: NOT BANIAS CPU



**A\_AD23 : CLOCK BYPASS DISABLE**  
 Default : 1  
 0: TEST MODE  
 1: NORMAL OPERATION



**A\_AD22 : OSC PAD OUTPUT PCICLK**  
 Default : 1  
 0: OSC PIN DRIVES PCICLK  
 1: OSC PIN DRIVES OSC CLK



**A\_AD21 : AUTO\_CAL ENABLE**  
 Default : 1  
 0: DISABLE AUTO\_CAL  
 1: ENABLE AUTO\_CAL

## RC300M STRAPPING



**A\_AD20 : INTERNAL CLK GEN ENABLE**  
 Default : 1  
 0: EXTERNAL CLOCK GENERATOR  
 1: INTERNAL CLOCK GENERATOR



**A\_AD19 : MEMORY IO VOLTAGE SELECTION**  
 Default : 1  
 0: 1.8V  
 1: 2.5V



**A\_AD18 : ENABLE PHASE CALIBRATION**  
 Default : 0  
 0: DISABLE  
 1: ENABLE



**PAR : EXTENDED DEBUG MODE**  
 Default : 1  
 0: DEBUG MODE  
 1: NORMAL OPERATION

緯創資通 Wistron Corporation  
 21F, 88, Sec.1, Hsin Tai Wu Rd., Hsichih, Taipei Hsien 221, Taiwan, R.O.C.

Title		<b>NB STRAPPING</b>	
Size	Document Number	Rev	
A3	<b>YUHINA2&amp;3</b>	-2	
Date: Thursday, April 08, 2004	Sheet 10	of	46

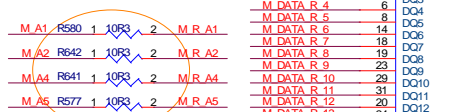
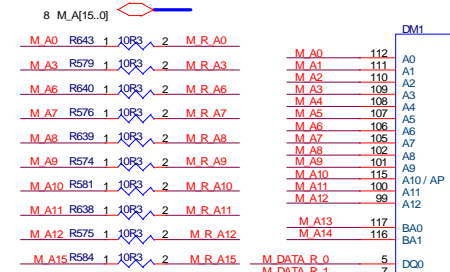

# REVERSE TYPE

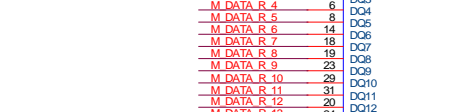
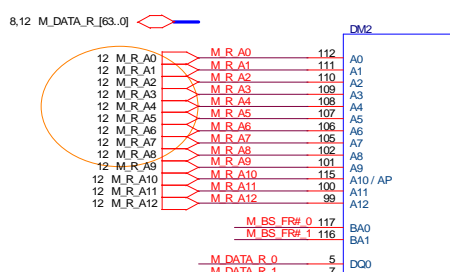
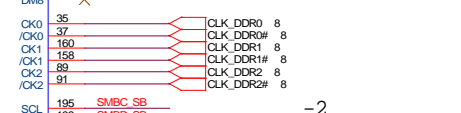
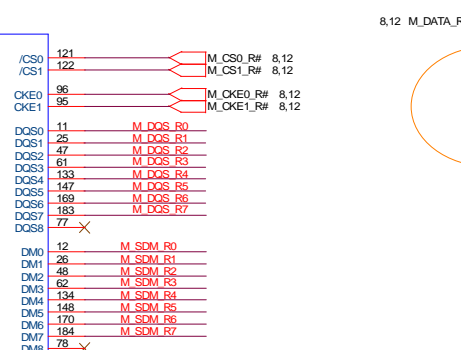

# NORMAL TYPE

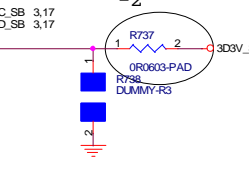
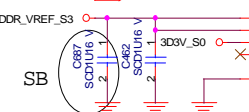
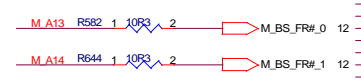
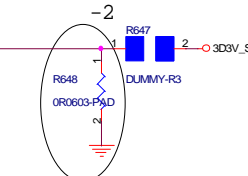
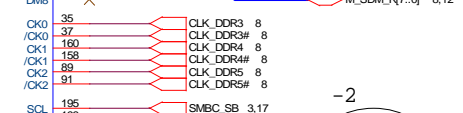
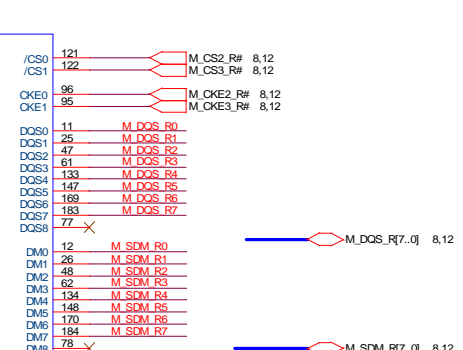

**緯創資通 Wistron Corporation**  
21F, 88, Sec. 1, Hsin Tai Wu Rd., Hsichih,  
Taipai Hsien 221, Taiwan, R.O.C.

Title: **DDR Socket**

Size: Custom Document Number: **YUHINA2&3** Rev: **-2**

Date: Thursday, April 08, 2004 Sheet 11 of 46

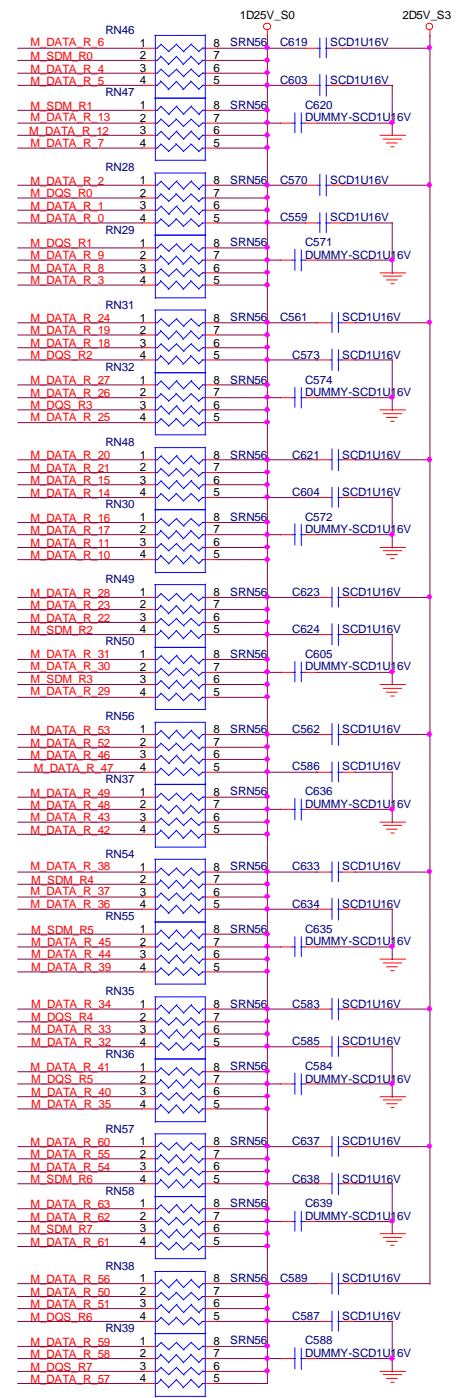
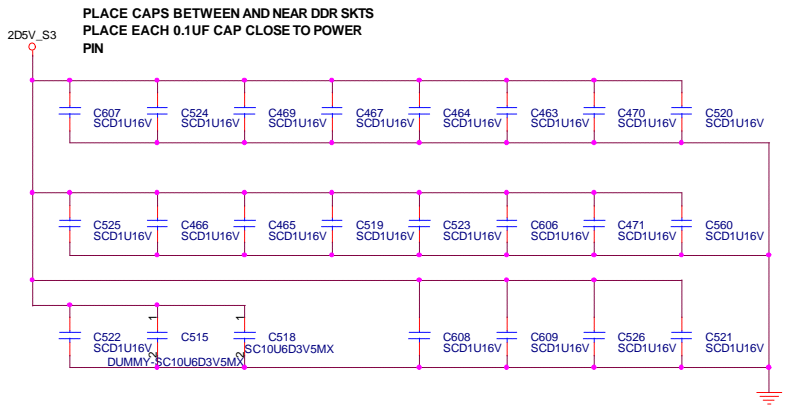

# PARALLEL TERMINATION

PULL HIGH STUBS < 0.8", PLACE Rps CLOSE TO DM2  
NO EQUAL LENGTH LIMITATION

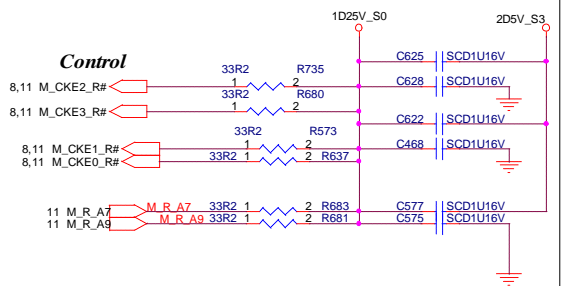
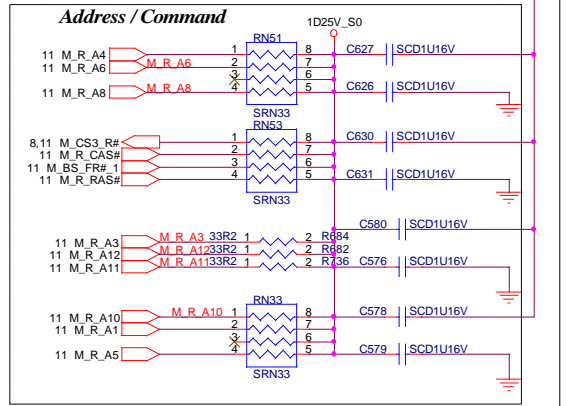
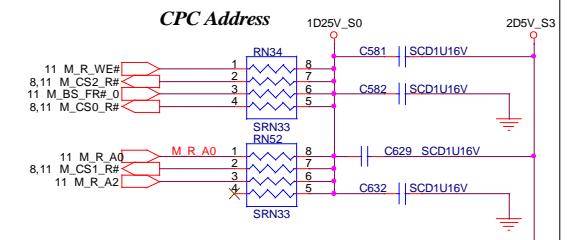
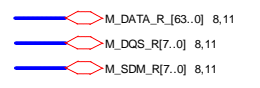

**緯創資通 Wistron Corporation**  
21F, 88, Sec. 1, Hsin Tai Wu Rd., Hsichih, Taipei Hsien 221, Taiwan, R.O.C.

Title		
DDR Serial/Terminator Resistor		
Size	Document Number	Rev
A3	YUHINA2&3	-2
Date: Thursday, April 08, 2004	Sheet 12 of 46	

# CRT I/F & CONNECTOR

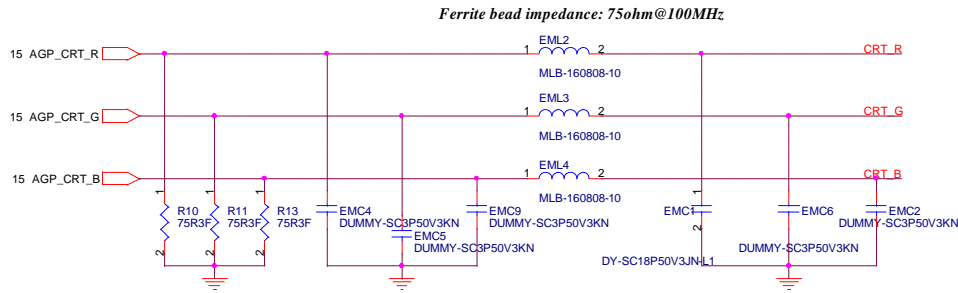

**Layout Note:**

- \* Must be a ground return path between this ground and the ground on the VGA connector.
- \* 37.4\_1% resistors must be placed at the same place as the RGB 75 Ohm pull-down resistors.

Pi-filter & 75 Ohm pull-down resistors should be as close as to CRT CONN. RGB will hit 75 Ohm first, pi-filter, then CRT CONN.

RDDP 1.0

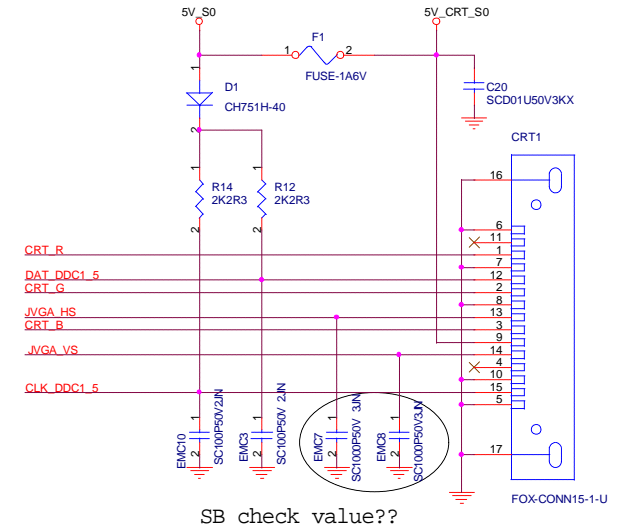

**Hsync & Vsync level shift**

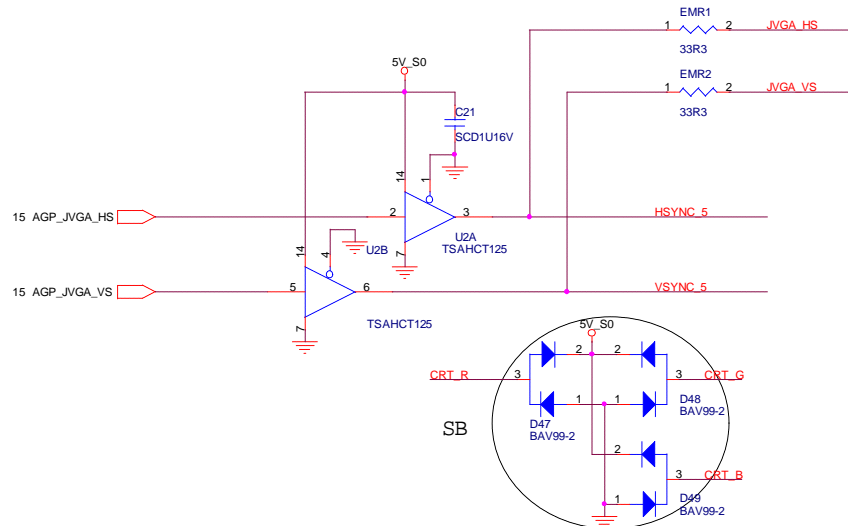

**DDC\_CLK & DATA level shift**

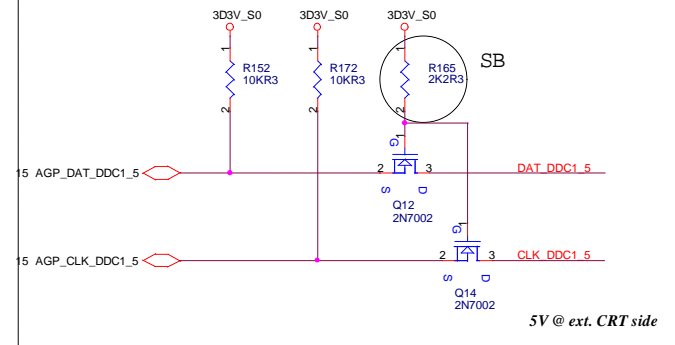

緯創資通 Wistron Corporation  
21F, 88, Sec.1, Hsin Tai Wu Rd., Hsichih, Taipei Hsien 221, Taiwan, R.O.C.

Title <b>CRT Connector</b>		
Size A3	Document Number <b>YUHINA2&amp;3</b>	Rev <b>-2</b>
Date: Thursday, April 08, 2004	Sheet 13 of	46

# LCD / INVERTER INTERFACE

TOP VIEW  
INV CONN

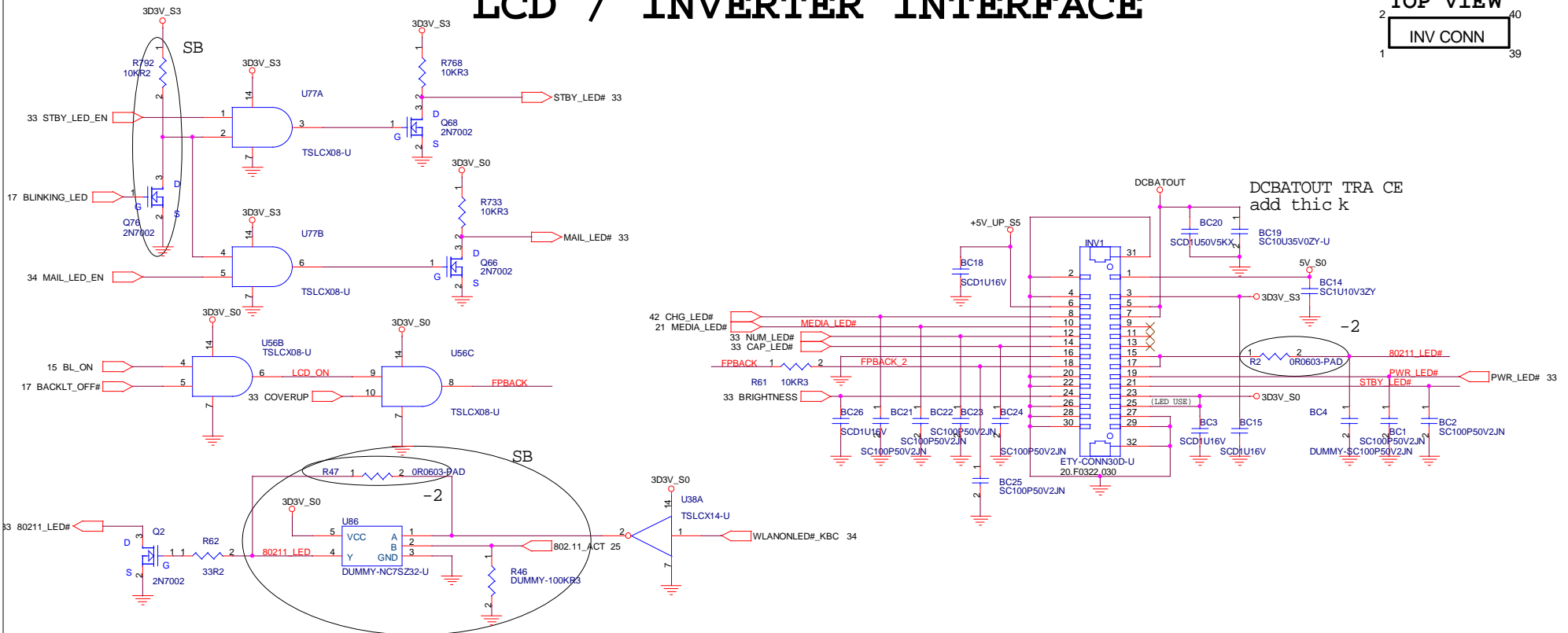

# LCD CONN

TOP VIEW  
LCD CONN

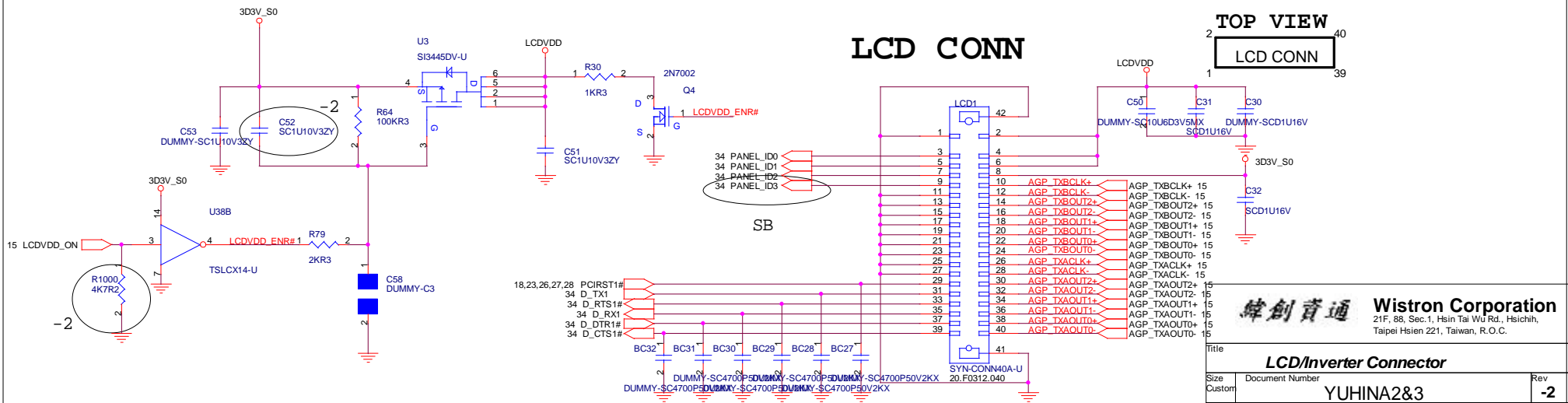

緯創資通 Wistron Corporation  
21F, 88, Sec.1, Hsin Tai Wu Rd., Hsichih, Taipei Hsien 221, Taiwan, R.O.C.

Title <b>LCD/Inverter Connector</b>		
Size Custom	Document Number <b>YUHINA2&amp;3</b>	Rev <b>-2</b>
Date: Thursday, April 08, 2004	Sheet 14 of	46

Select Int./Ext. VGA

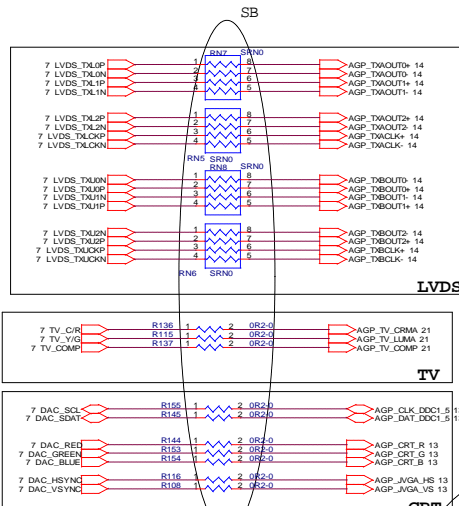

(Close to the AGP connector)

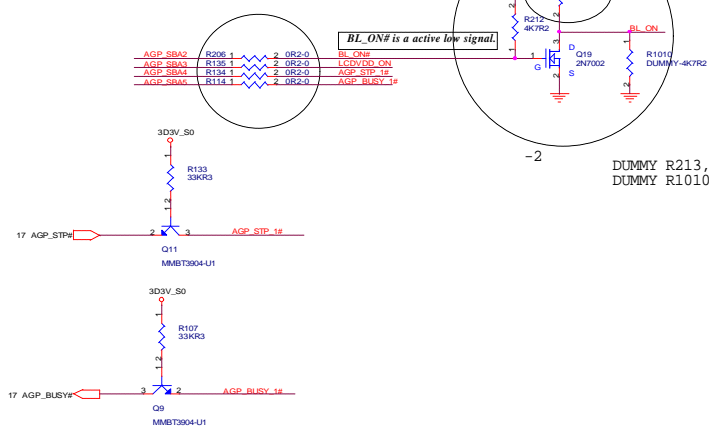

DUMMY R213,R212 for discrete  
DUMMY R1010 for UMA

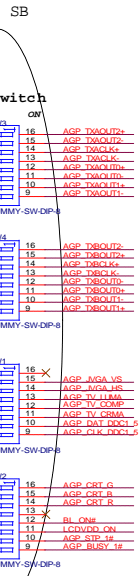

AGP Connector

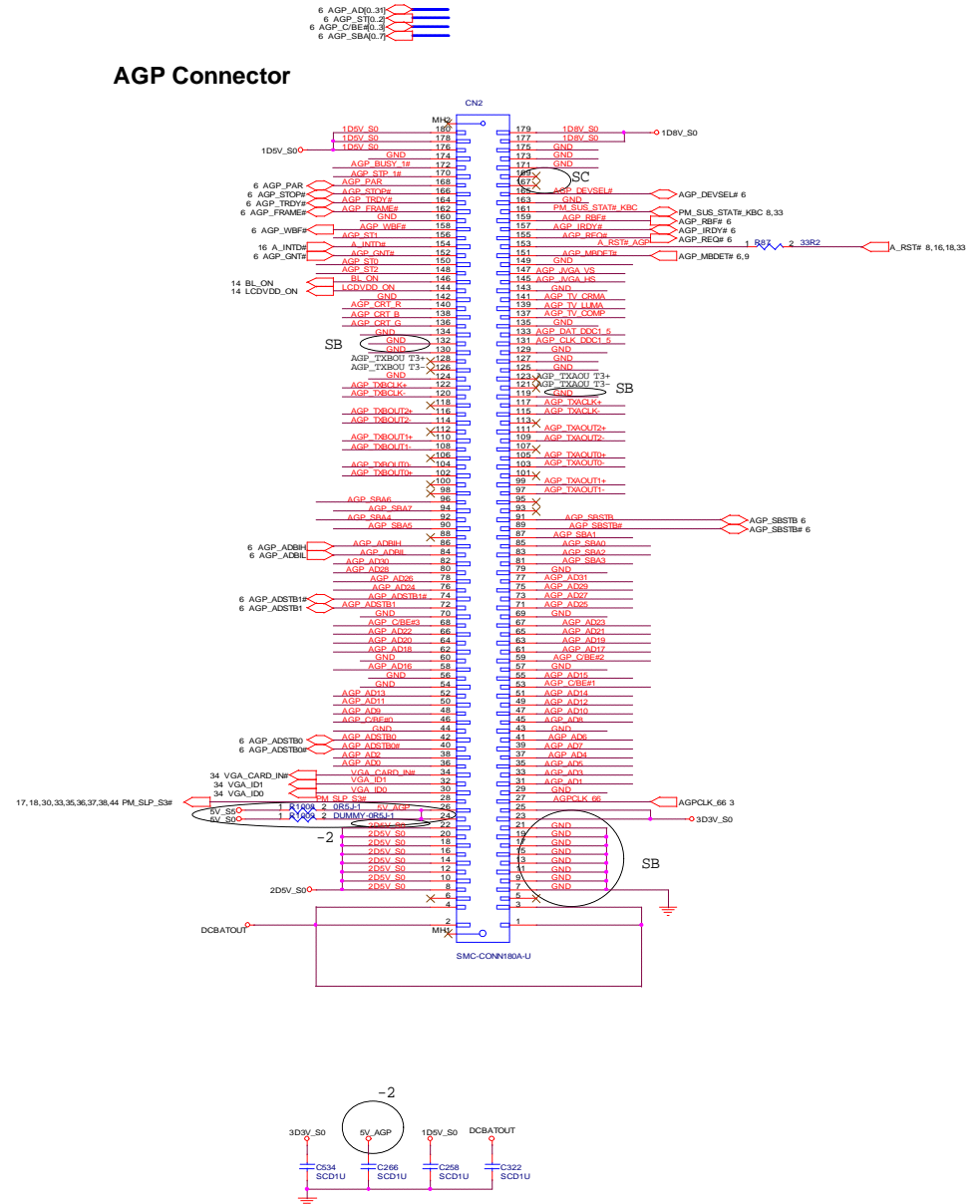

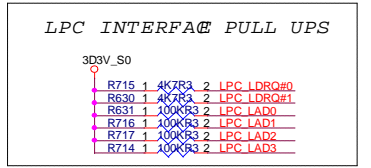
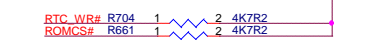
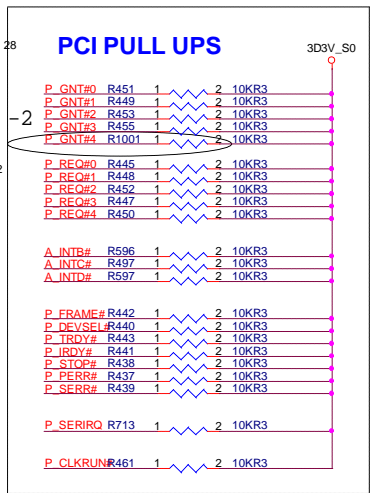
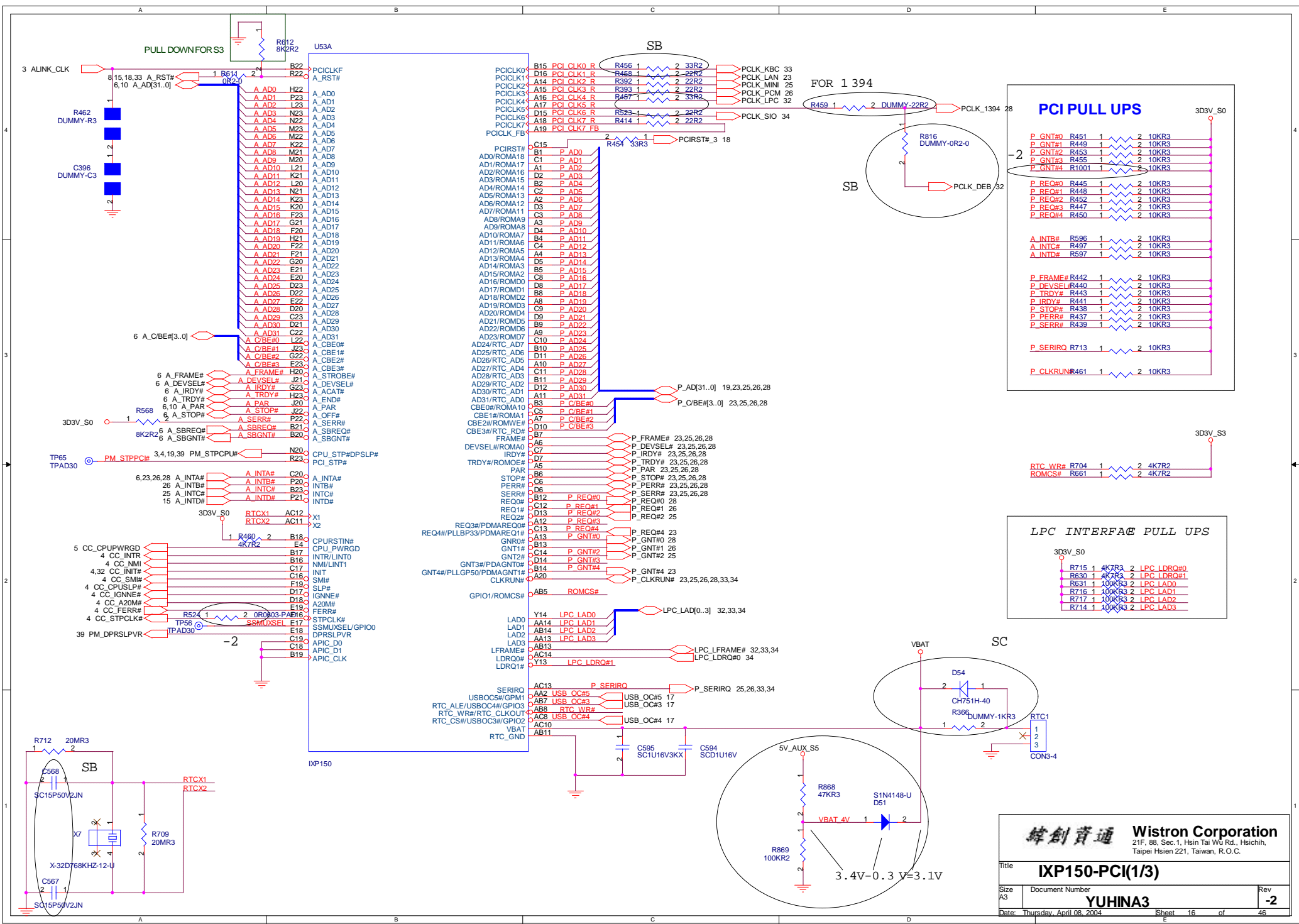

**緯創資通 Wistron Corporation**  
 21F, 88, Sec. 1, Hsin Tai Wu Rd., Hsichih, Taipei Hsien 221, Taiwan, R.O.C.

Title: **IXP150-PCI(1/3)**

Size A3	Document Number	Rev
	<b>YUHINA3</b>	<b>-2</b>

Date: Thursday, April 08, 2004 Sheet 16 of 46



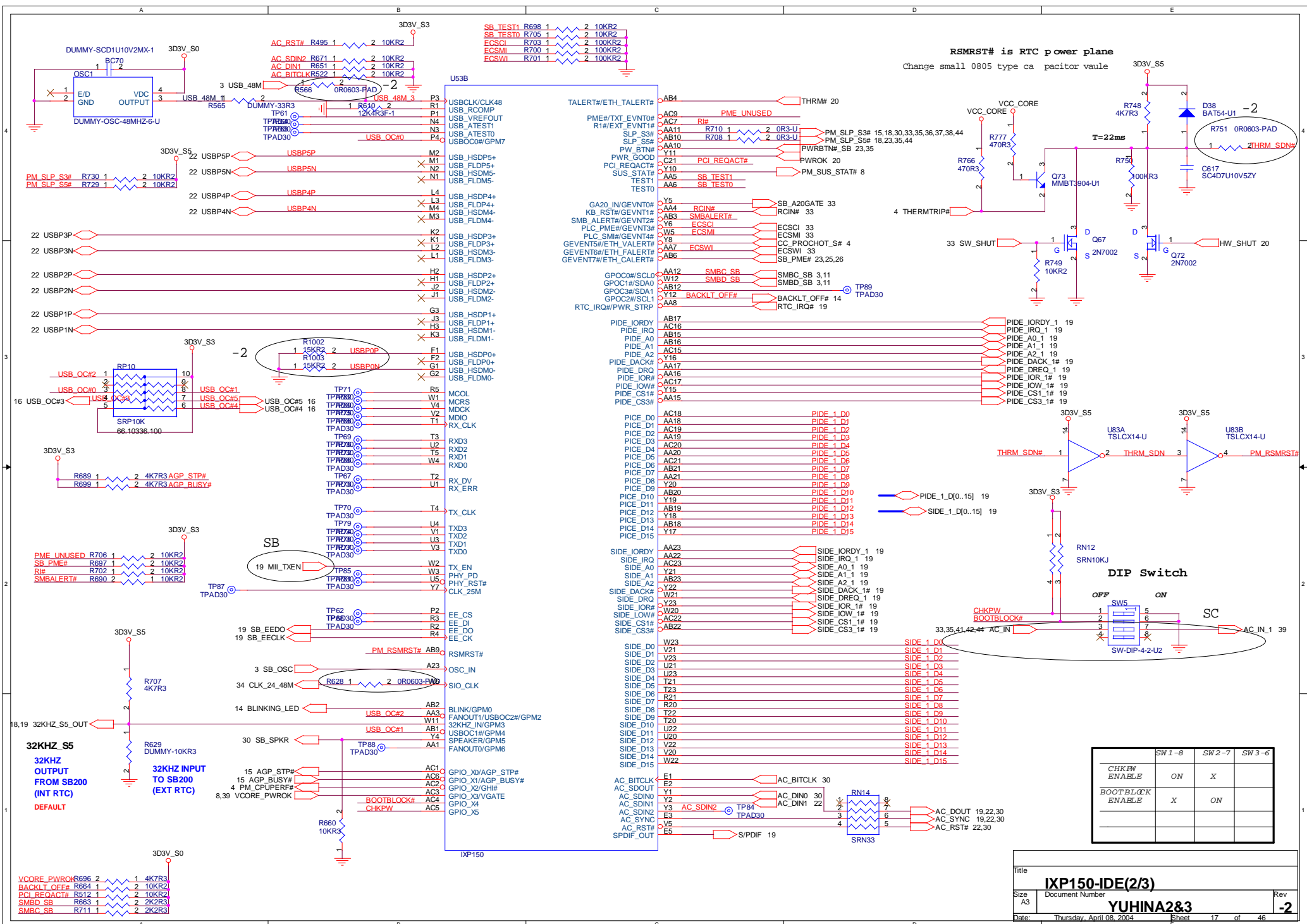

RSMRST# is RTC power plane  
 Change small 0805 type capacitor value

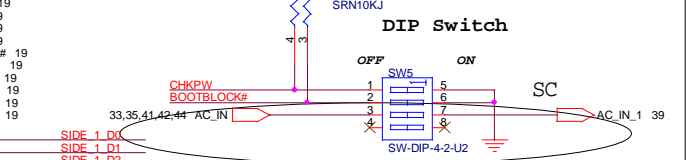
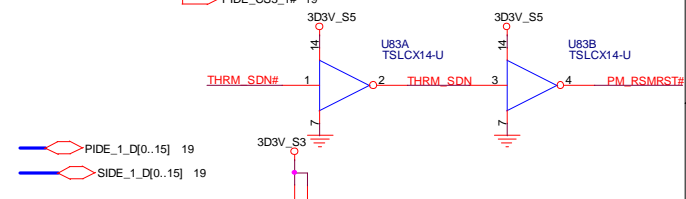
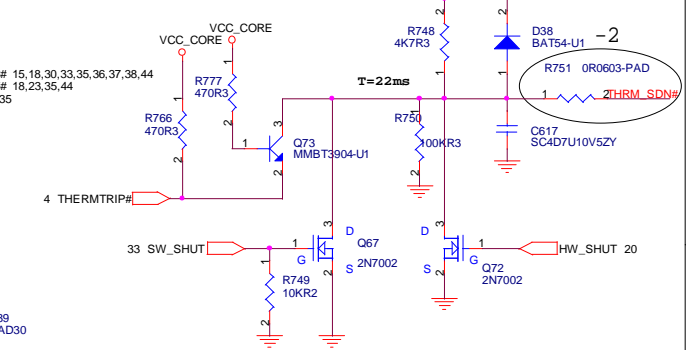

	SW 1-8	SW 2-7	SW 3-6
CHKPW ENABLE	ON	X	
BOOTBLK ENABLE	X	ON	

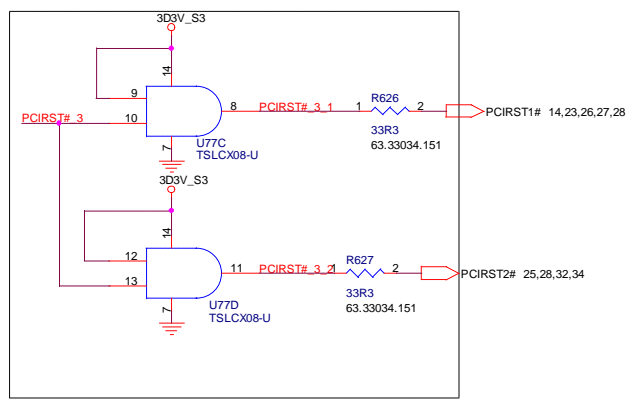
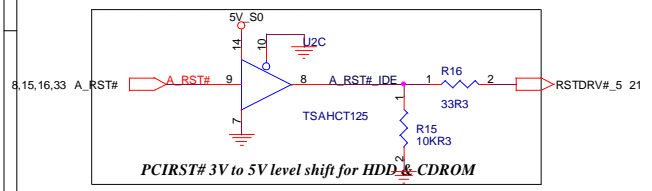
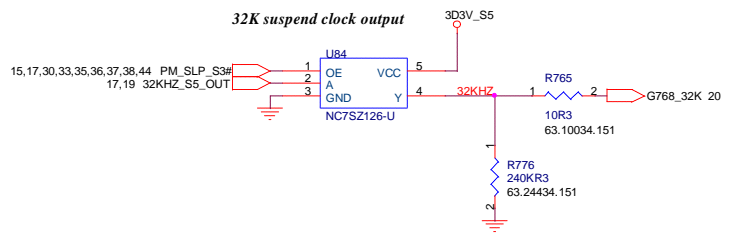

**Power Consumption**

- 3D3V\_S5: 340uA
- 2D5V\_S5: 6D8mA
- 3D3V\_S3: 156mA
- 2D5V\_S3: 48mA
- 3D3V\_S0: 40mA
- 2D5\_S0: 302mA
- 5V\_S0: 70uA
- VCC\_CORE\_S0: 100mA

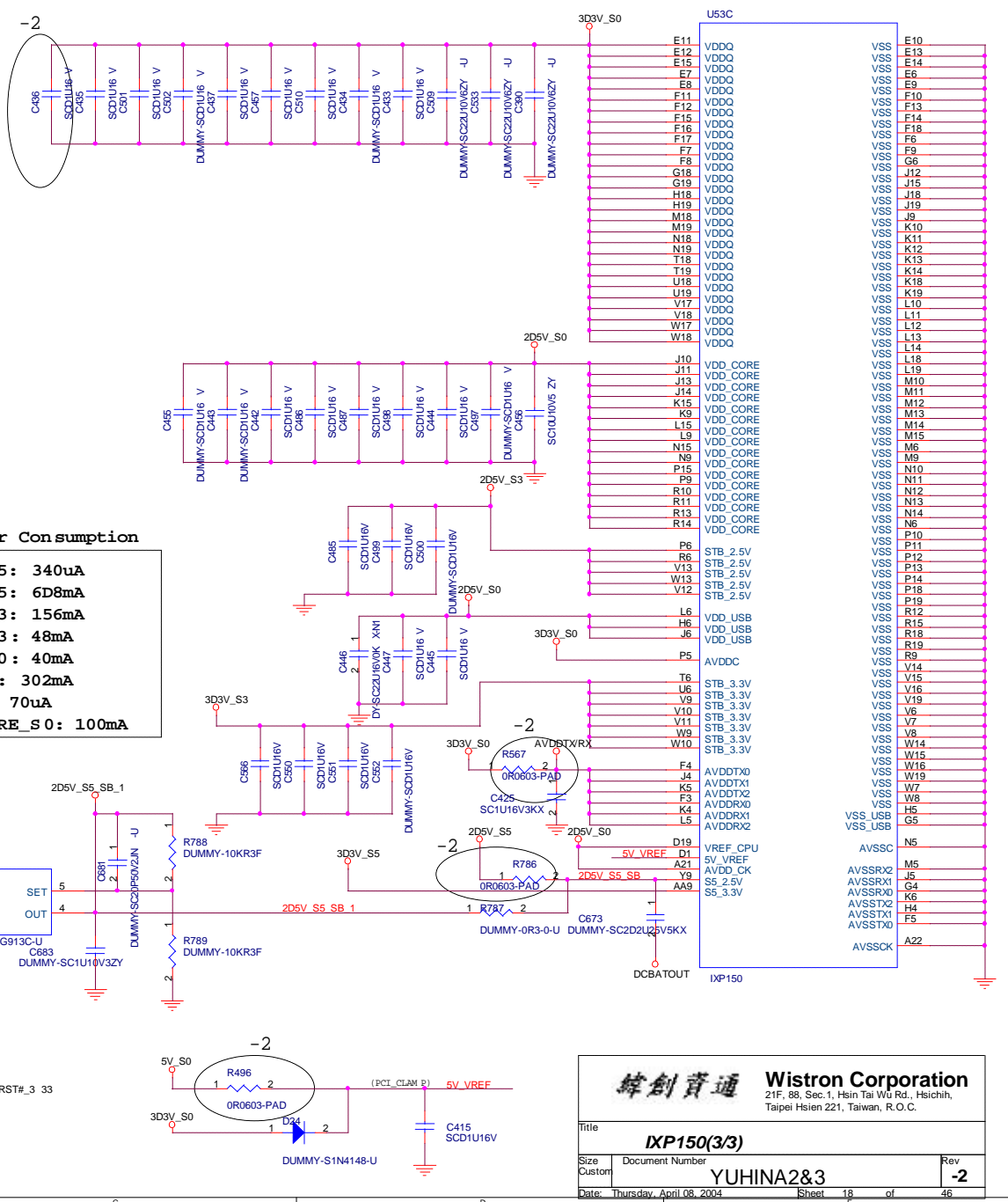
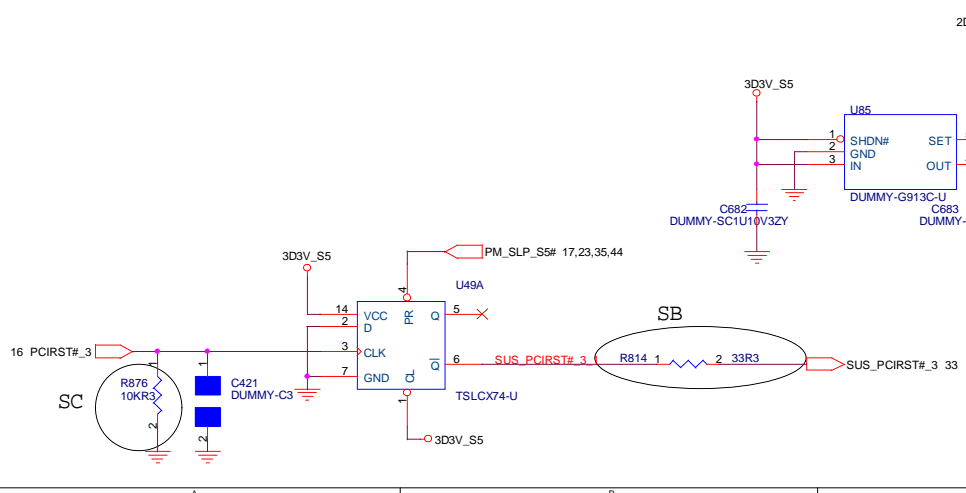

**緯創資通 Wistron Corporation**  
21F, 88, Sec. 1, Hsin Tai Wu Rd., Heichih,  
Taipei Hsien 221, Taiwan, R.O.C.

Title: **IXP150(3/3)**

Size: Custom    Document Number: **YUHINA2&3**    Rev: **-2**

Date: Thursday, April 08, 2004    Sheet 18 of 46

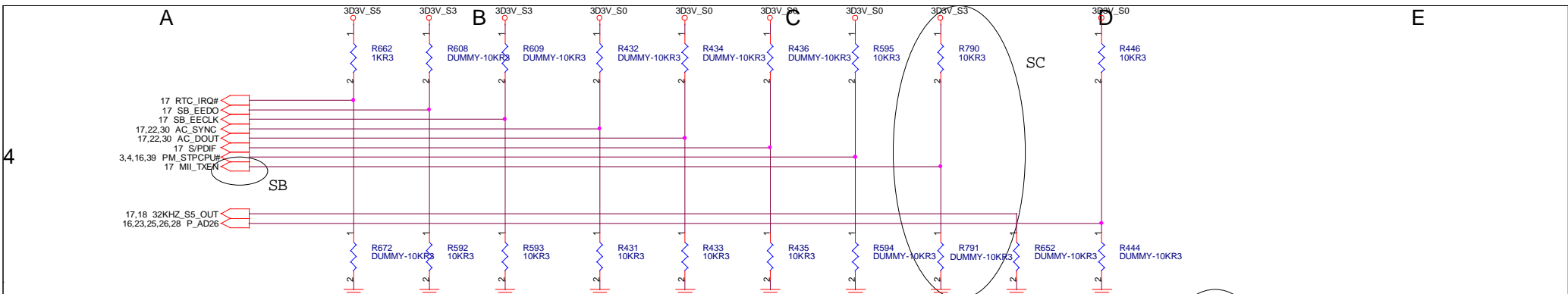

**REQUIRED SYSTEM STRAPS**

OVERLAP COMMON PADS  
FOR DUAL -OP  
RESISTORS

	ACPWRON	EEDO	EECK	AC_SYNC	AC_SDOOUT	SPDIF_OUT	CPU_STP#	32KHZ_S5	PCI_AD26	TX_EN
<b>STRAP HIGH</b>	MANUAL PWR ON DEFAULT	USE DEBUG STRAPS DEFAULT	ROM ON PCI BUS DEFAULT	INIT ACTIVE HIGH(AMD) DEFAULT	33MHz NB BUS DEFAULT	SIO 24MHz DEFAULT	ENABLE SPEED STEP DEFAULT	32KHZ OUTPUT FROM SB200 (INT RTC) DEFAULT	BIOS use LPC cycle DEFAULT	DISABLE CPU FREQ SETTING DEFAULT
<b>STRAP LOW</b>	AUTO PWR ON	IGNORE DEBUG STRAPS	ROM ON LPC BUS DEFAULT	INIT ACTIVE LOW (PIII) DEFAULT	HI SPEED A-LINK DEFAULT	SIO 48MHz DEFAULT	DISABLE SPEED STEP	32KHZ INPUT TO SB200 (EXT RTC)	BIOS uSE FWH Cycle	ENABLE CPU FREQSETTING

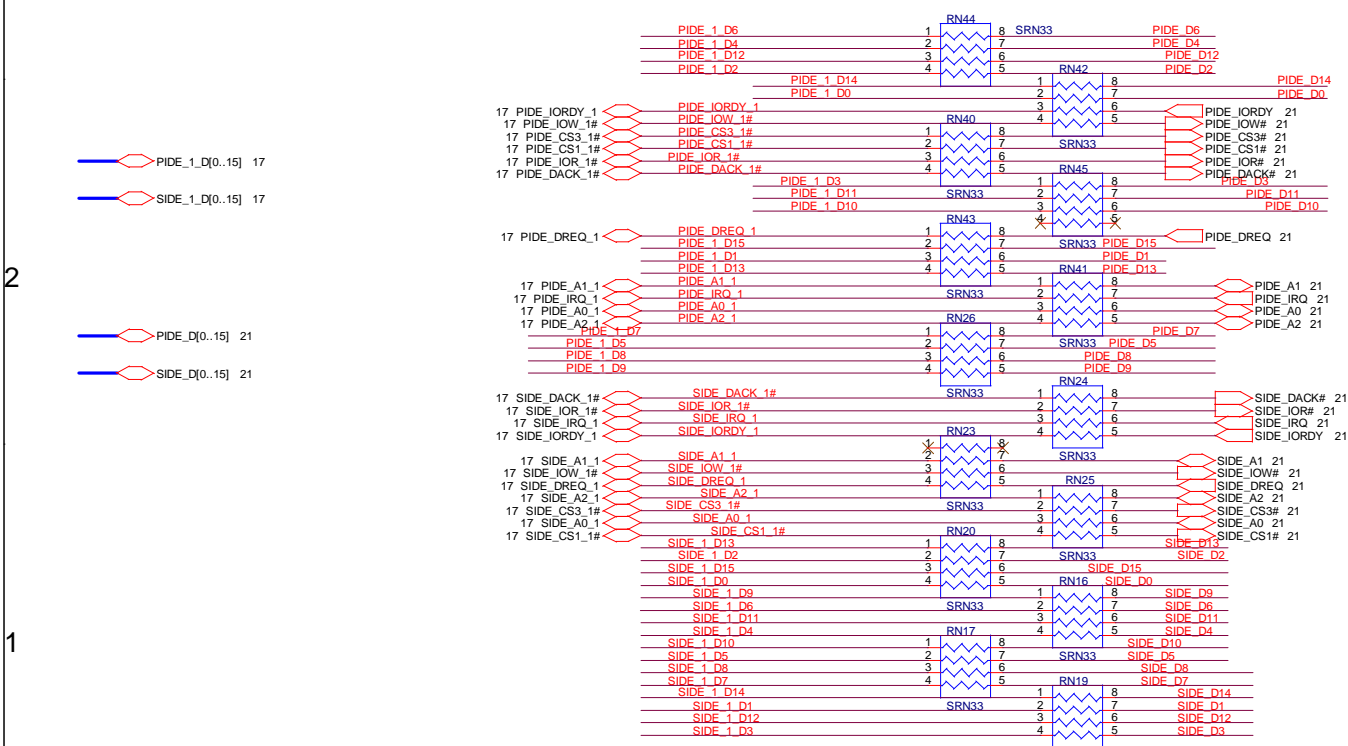

**Wistron Corporation**  
 21F, 88, Sec.1, Hsin Tai Wu Rd., Hsichih,  
 Taipei Hsien 221, Taiwan, R.O.C.

Title <b>SB STRAPPING</b>		
Size A3	Document Number <b>YUHINA2&amp;3</b>	Rev <b>-2</b>
Date: Thursday, April 08, 2004	Sheet 19	of 46

# G768D thermal sensor & Fan controller

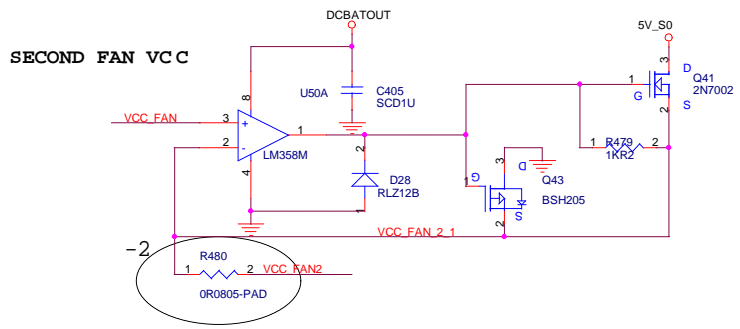
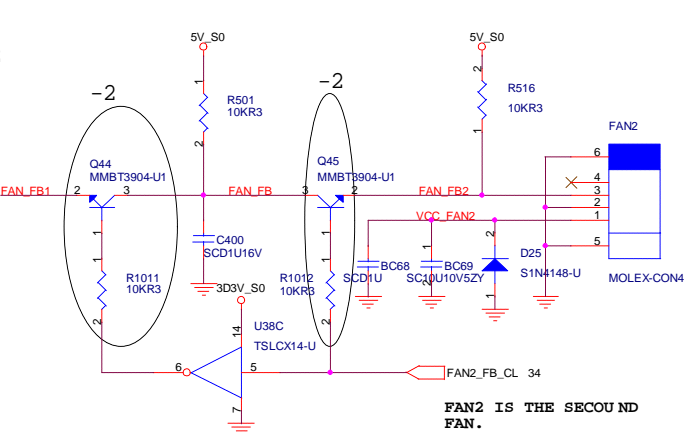
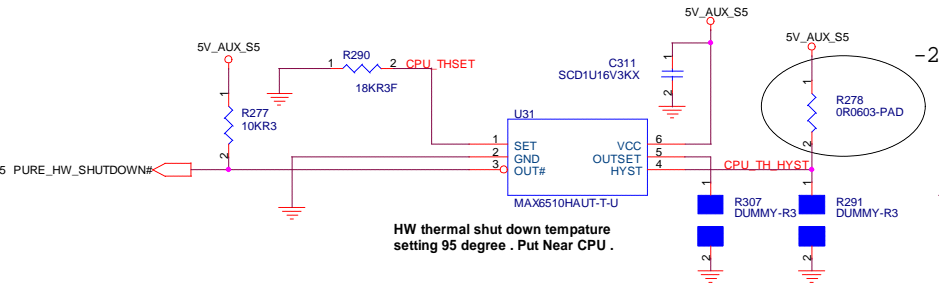
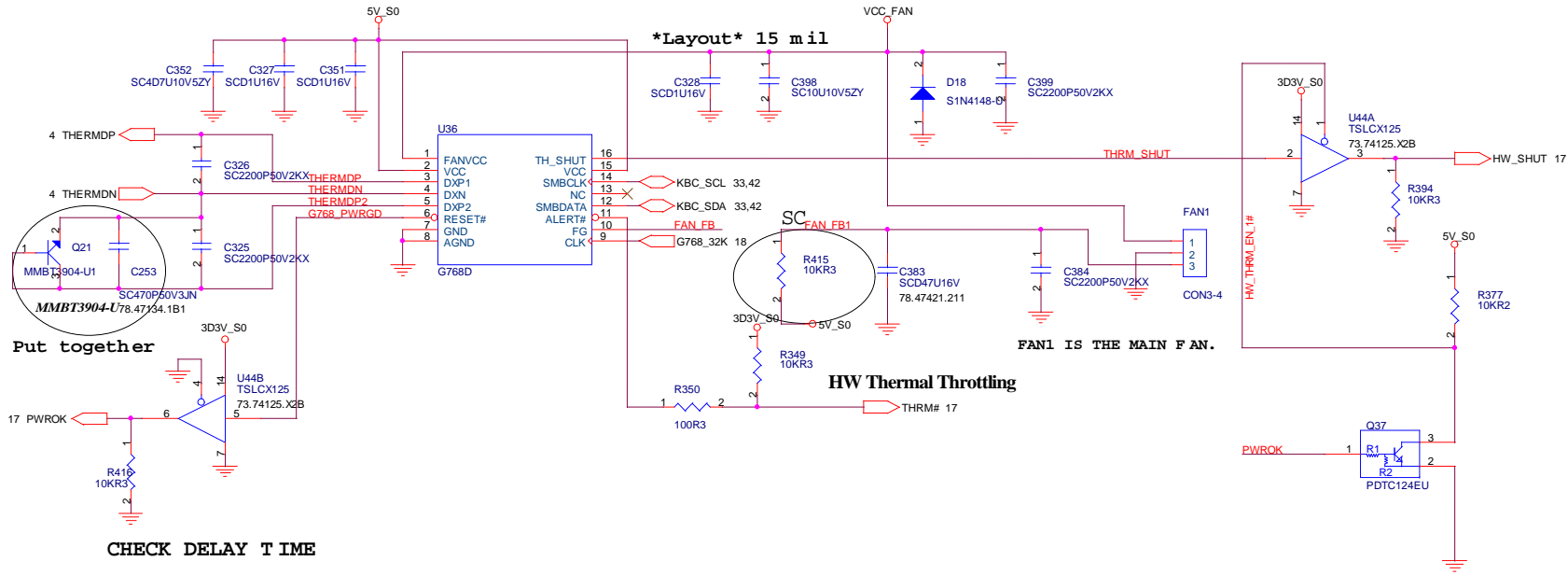

# CD-ROM CONN

## HDD Connector

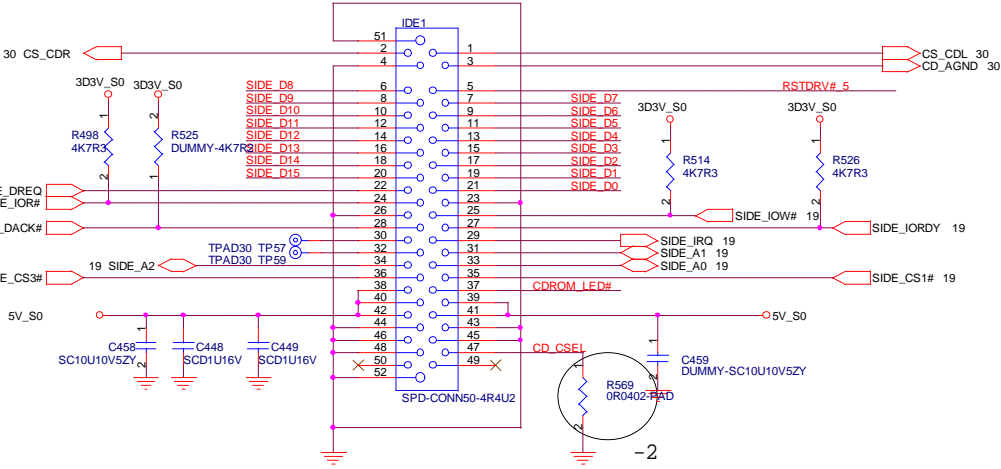
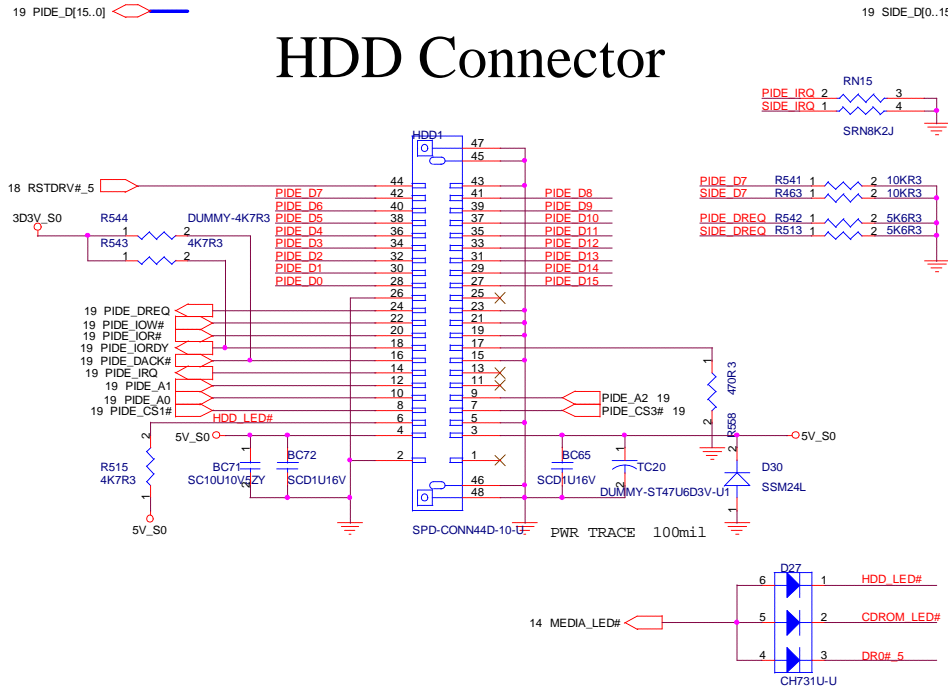

CHECK PIDE/SIDE DIAG# PIN

## FDD Connector

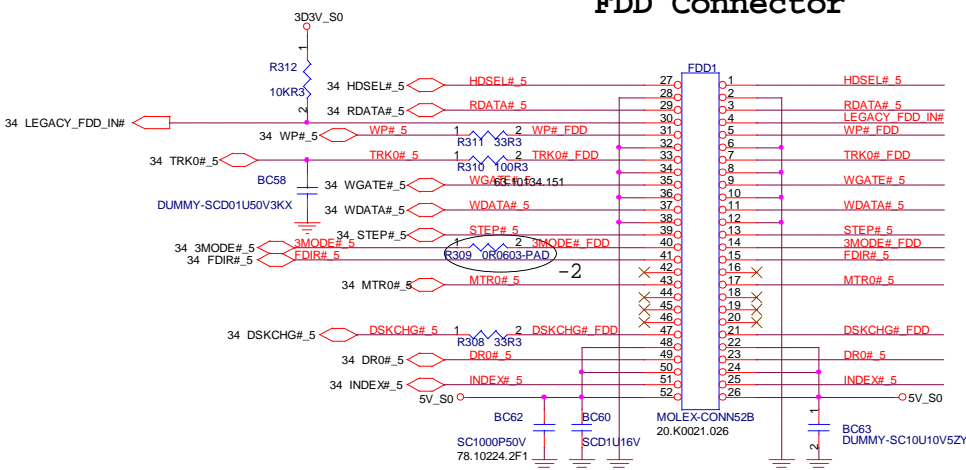

## TV CONN

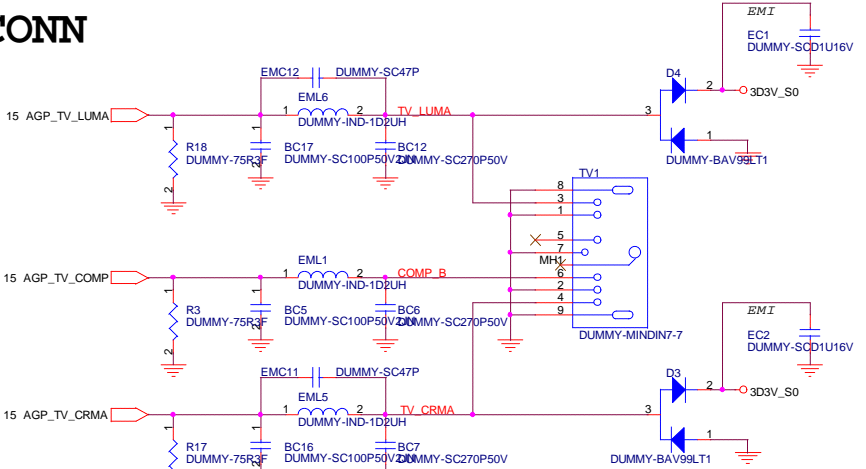

**緯創資通** **Wistron Corporation**  
 21F, 88, Sec.1, Hsin Tai Wu Rd., Hsichih, Taipei Hsien 221, Taiwan, R.O.C.

Title: **HDD and CDROM and FDD CONN/TV CONN**

Size A3	Document Number	Rev
	<b>YUHINA2&amp;3</b>	<b>-2</b>
Date: Thursday, April 08, 2004	Sheet 21	of 46

# USB PORT

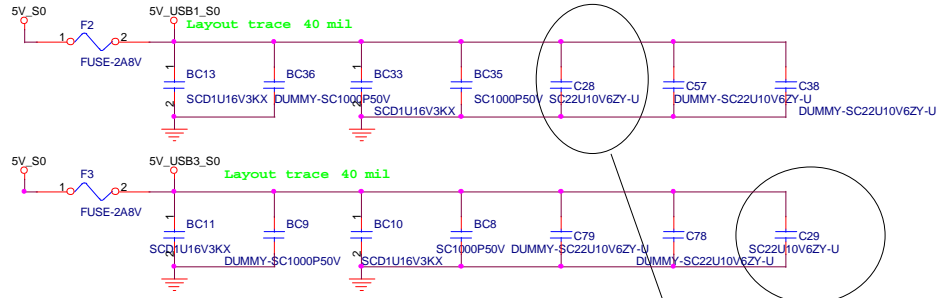

-2

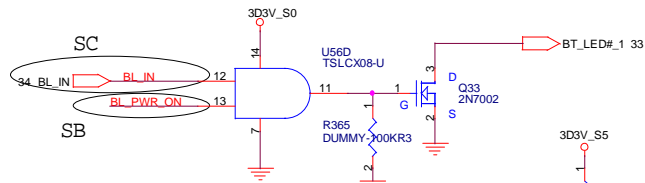

# MDC/BT

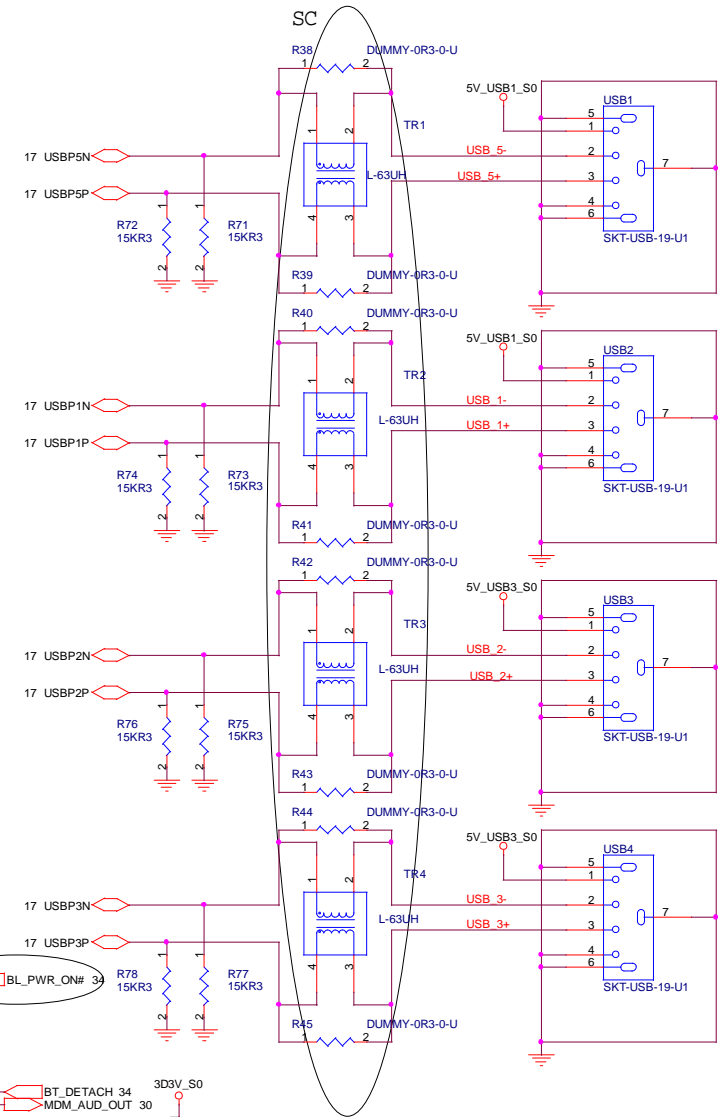
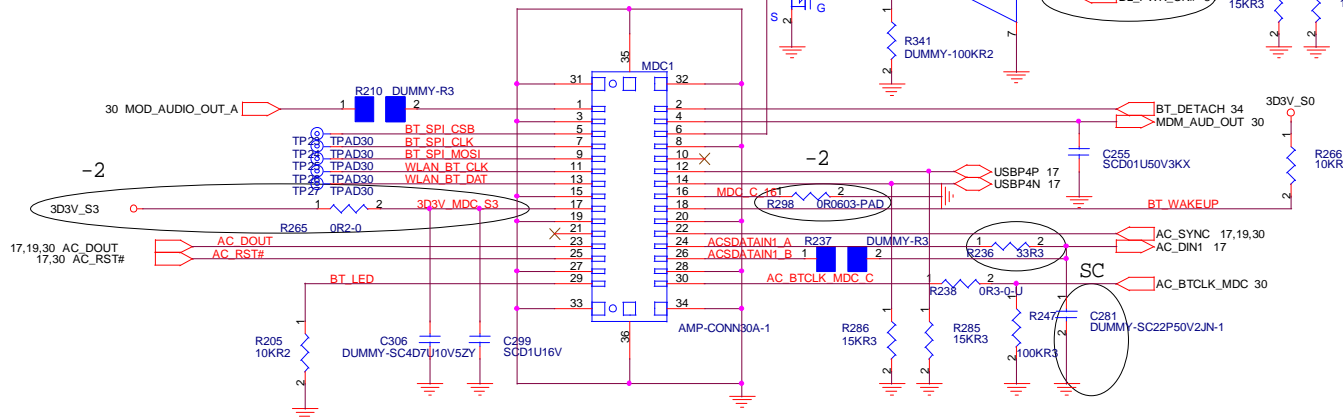

**緯創資通** Wistron Corporation  
 21F, 88, Sec.1, Hsin Tai Wu Rd., Hsichih,  
 Taipei Hsien 221, Taiwan, R.O.C.

Title		
<b>USB and MDC/BT IF and LAN</b>		
Size	Document Number	Rev
A3	YUHINA2&3	-2
Date: Thursday, April 08, 2004	Sheet 22	of 46

Close to RTL8100C  
Pin121, Pin122

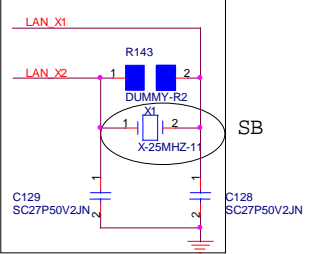

SB

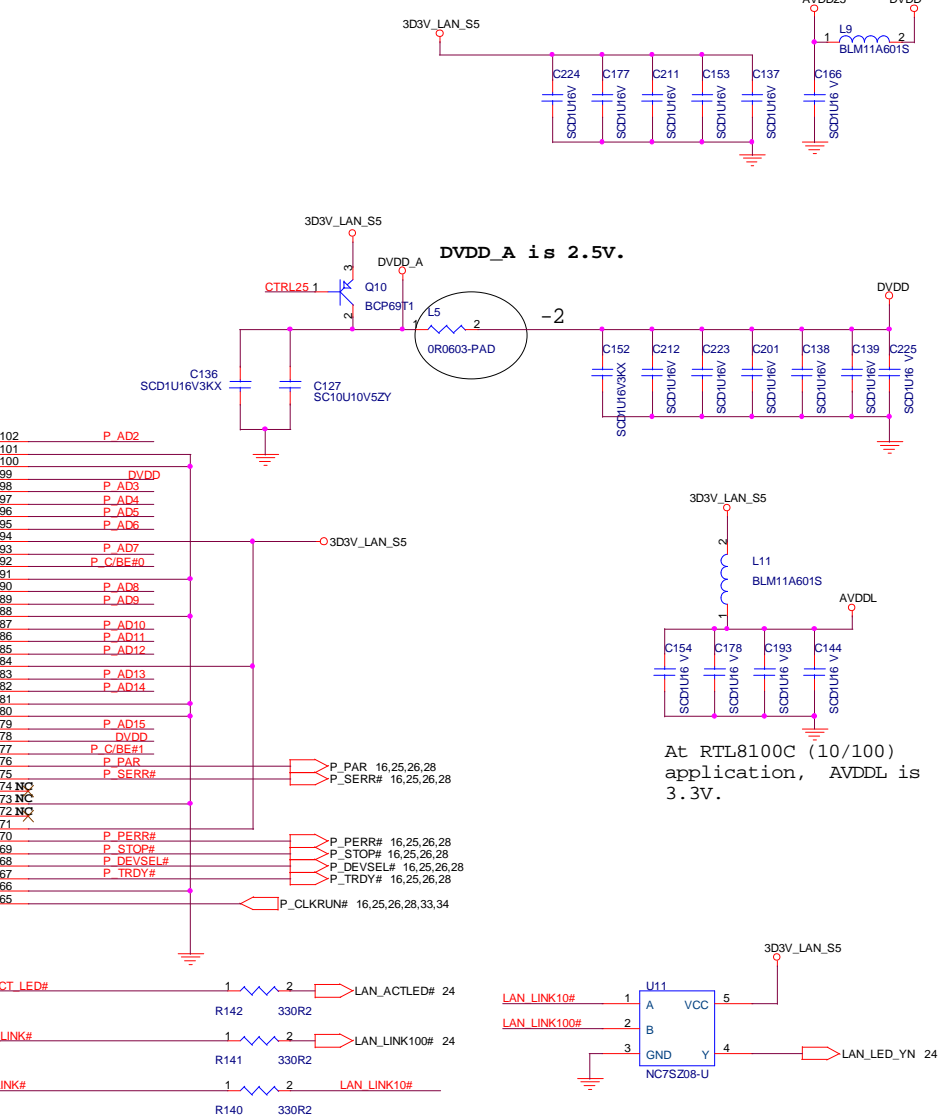
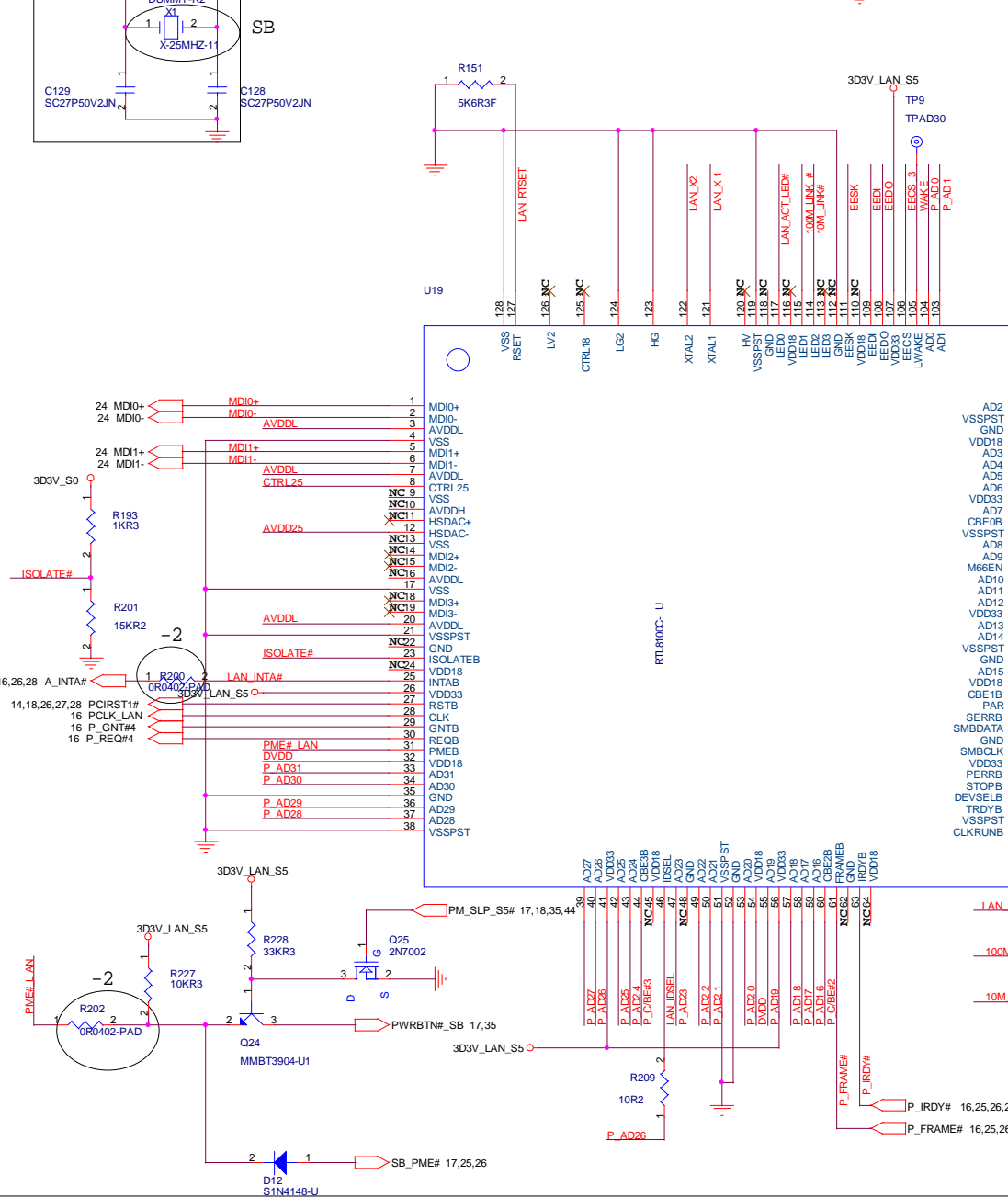
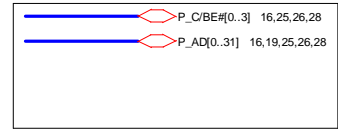
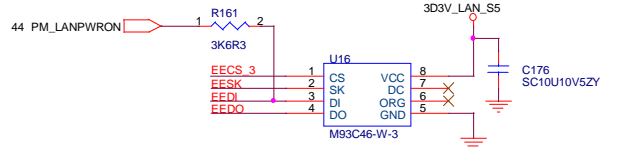

DVDD\_A is 2.5V.

At RTL8100C (10/100) application, AVDDL is 3.3V.

**Wistron Corporation**  
 21F, 88, Sec. 1, Hsin Tai Wu Rd., Hsichih, Taipei Hsien 221, Taiwan, R.O.C.

---

Title: **LAN RTL8100C**  
 Size A3 | Document Number: **YUHINA2&3** | Rev: **-2**  
 Date: Tuesday, April 27, 2004 | Sheet 23 of 46

# LAN Connector

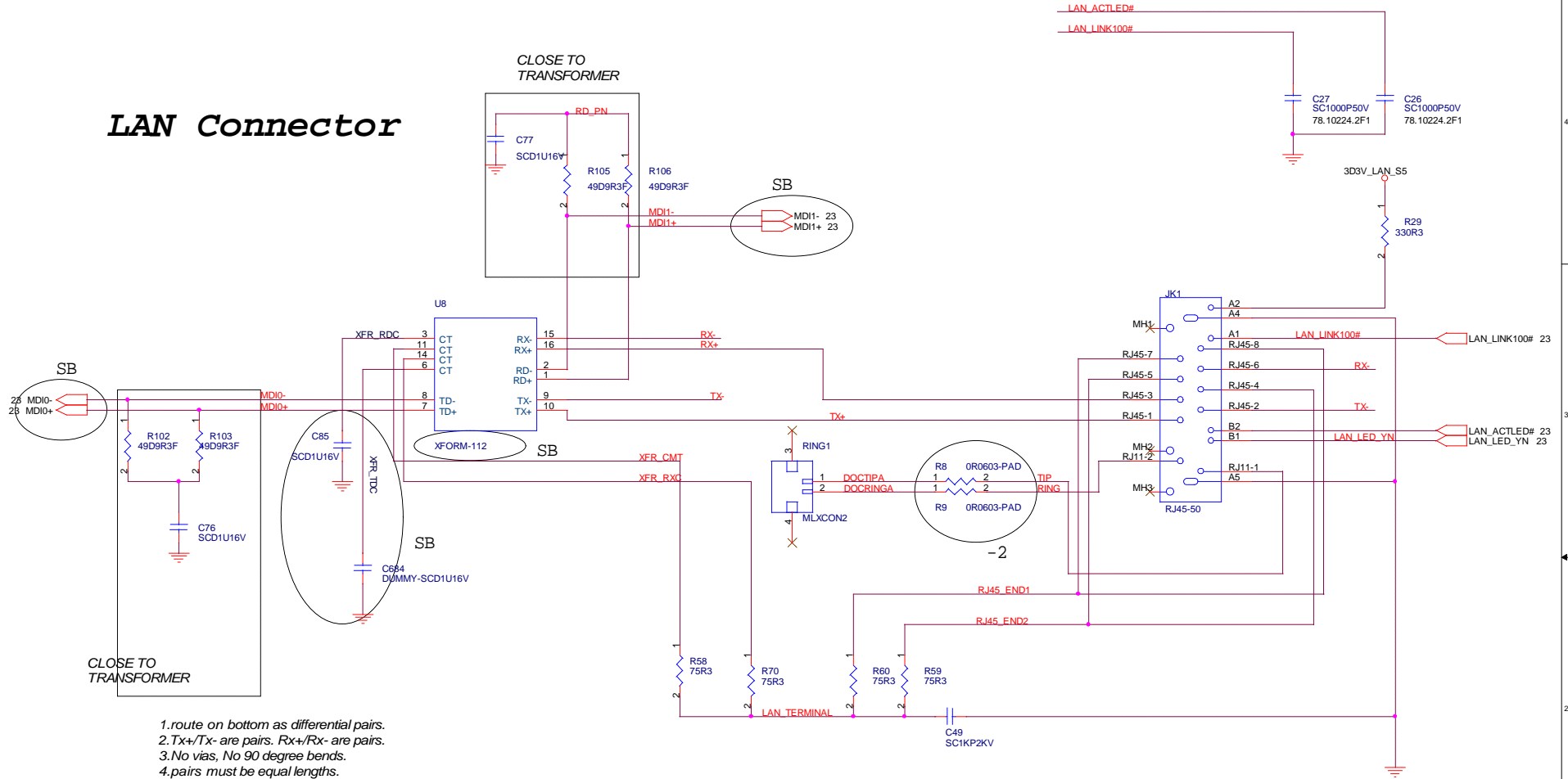

1. route on bottom as differential pairs.
2. Tx+/Tx- are pairs. Rx+/Rx- are pairs.
3. No vias, No 90 degree bends.
4. pairs must be equal lengths.
5. 6mil trace width, 12mil separation.
6. 36mil between pairs and any other trace.
7. Must not cross ground moat, except RJ-45 moat.

DOC\_TIP, DOC\_RING, TIP, RING:  
 W/S : 10/100 @ Surface layers  
 10/20 @ Inner layers

Green LED---Speed100:ON/Speed10:OFF  
 Yellow LED---Link:ON ,TX/RX:Flash



# Mini PCI

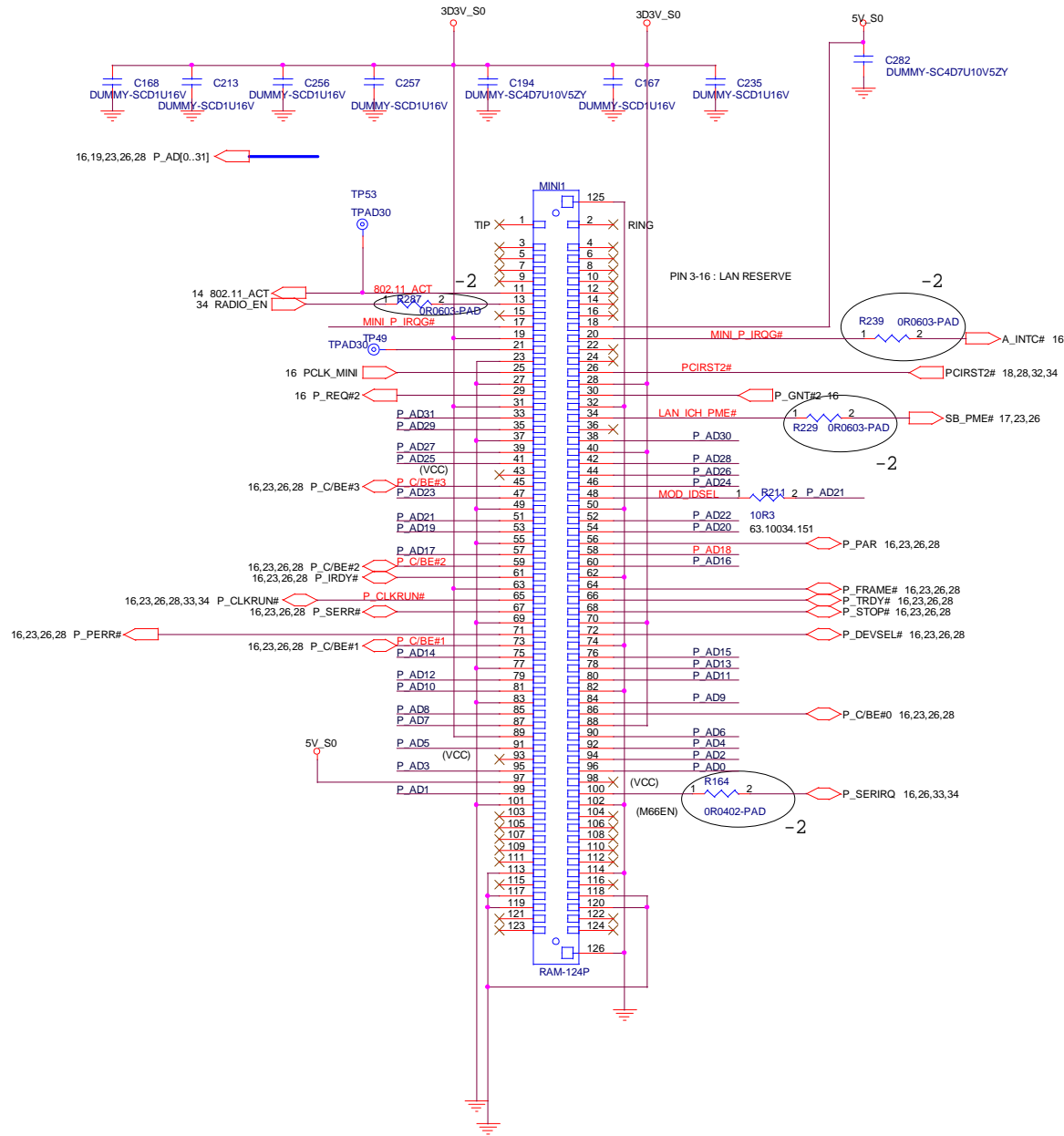

緯創資通 **Wistron Corporation**  
 21F, 88, Sec. 1, Hsin Tai Wu Rd., Hsichih,  
 Taipei Hsien 221, Taiwan, R.O.C.

Title <b>MINI-PCI</b>		
Size A3	Document Number <b>YUHINA2&amp;3</b>	Rev <b>-2</b>
Date: Thursday, April 08, 2004	Sheet 25 of 46	

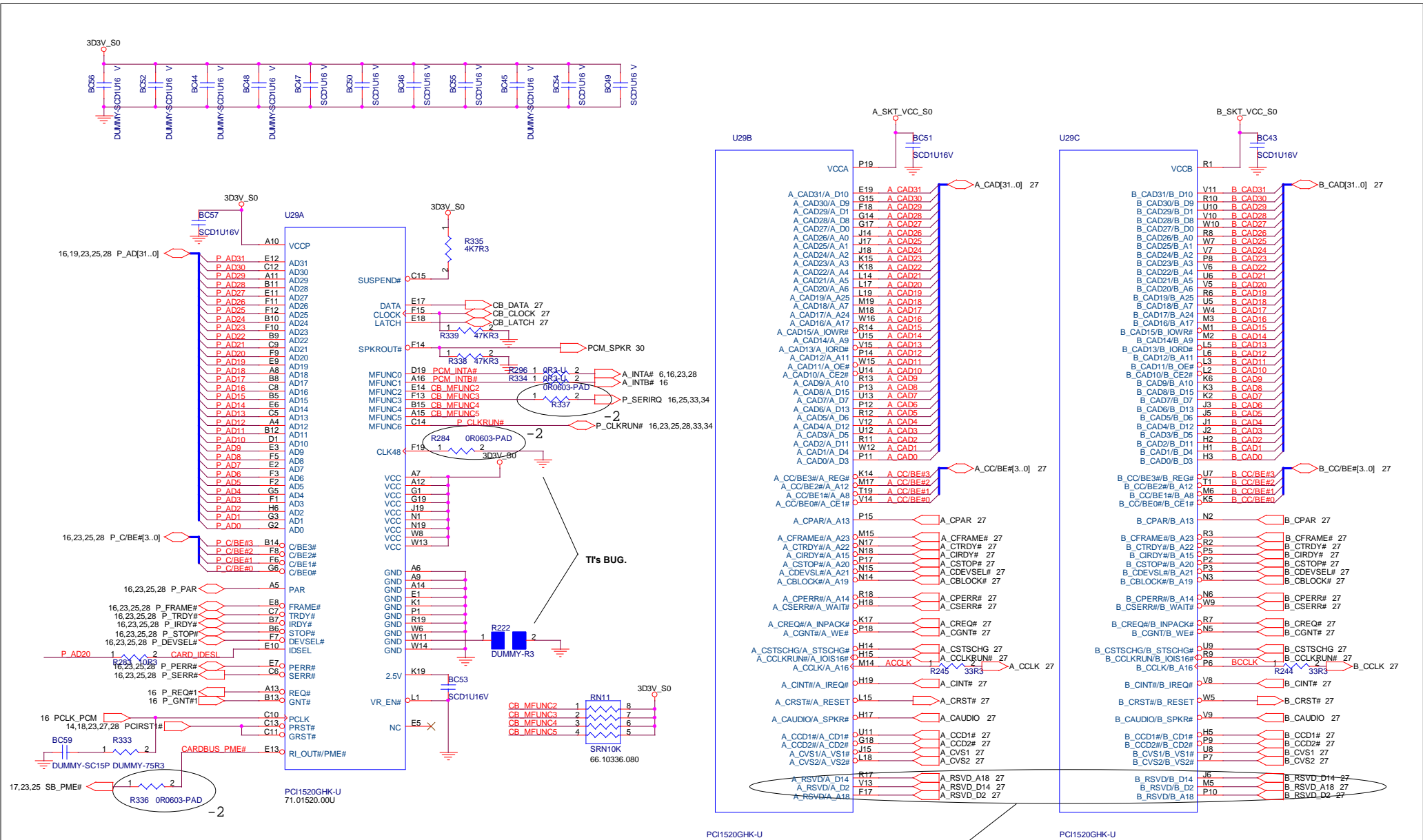

**Library Error !!**  
 R17 - A\_A18      M5 - B\_A18  
 V13 - A\_D14      P10 - B\_D2  
 F17 - A\_D2

**緯創資通**      **Wistron Corporation**  
 21F, 88, Sec.1, Hsin Tai Wu Rd., Hsichih,  
 Taipei Hsien 221, Taiwan, R.O.C.

Title: **CARDBUS T1520**

Size: A3	Document Number: <b>YUHINA2&amp;3</b>	Rev: <b>-2</b>
Date: Thursday, April 08, 2004	Sheet: 26	of 46

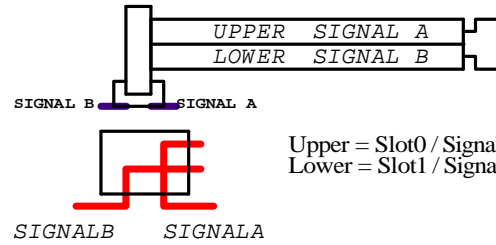
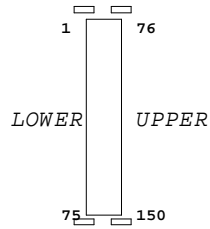
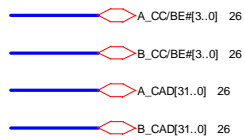

Upper = Slot0 / Signal A = Conn B  
Lower = Slot1 / Signal B = Conn A

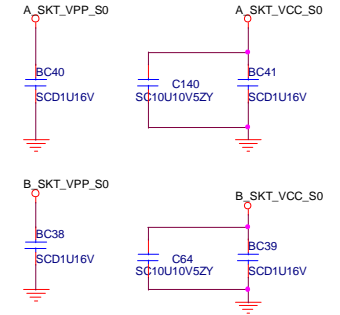
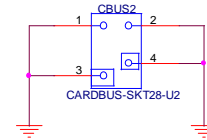
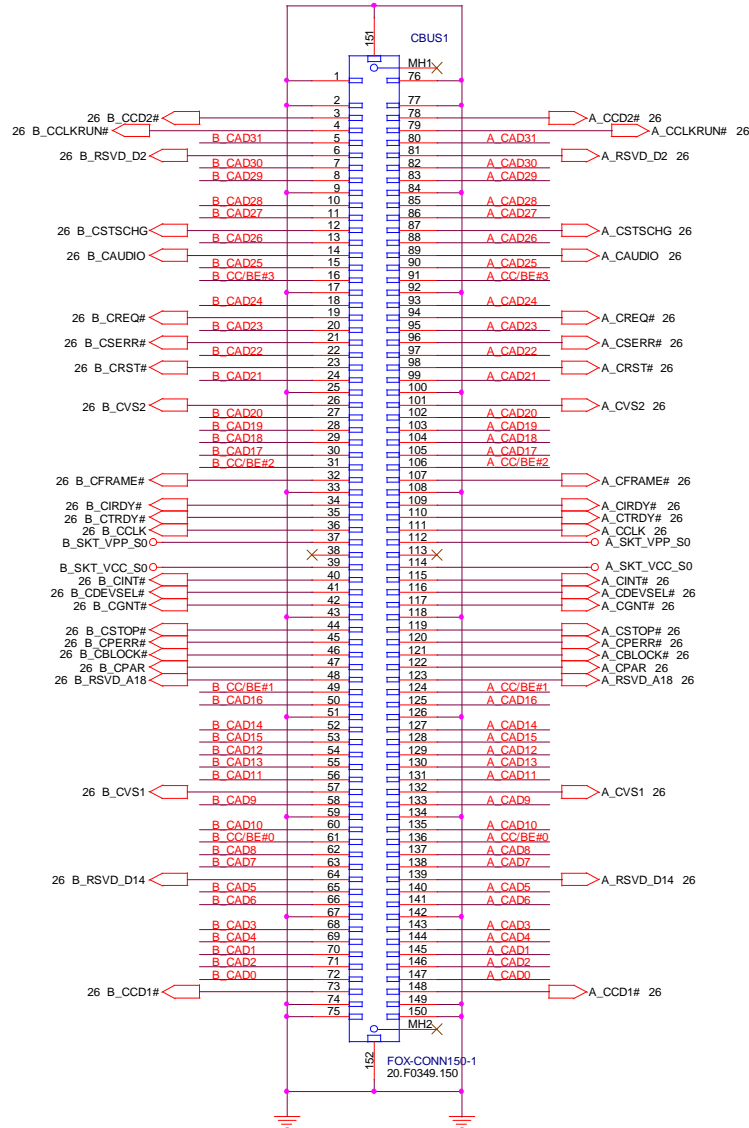
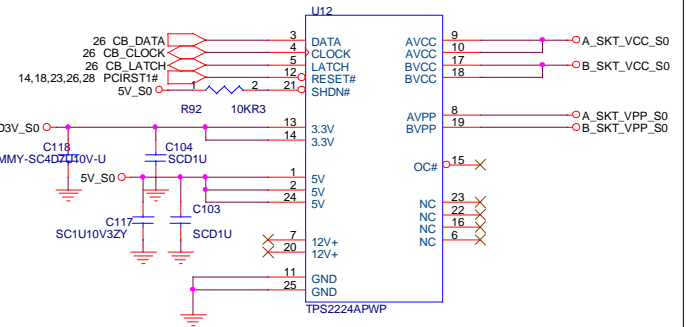

<b>緯創資通 Wistron Corporation</b> 21F, 88, Sec.1, Hsin Tai Wu Rd., Hsichih, Taipei Hsien 221, Taiwan, R.O.C.		
Title <b>CARBUS CONN / PWR SW</b>		
Size A3	Document Number <b>YUHINA2&amp;3</b>	Rev <b>-2</b>
Date: Thursday, April 08, 2004 Sheet 27 of 46		

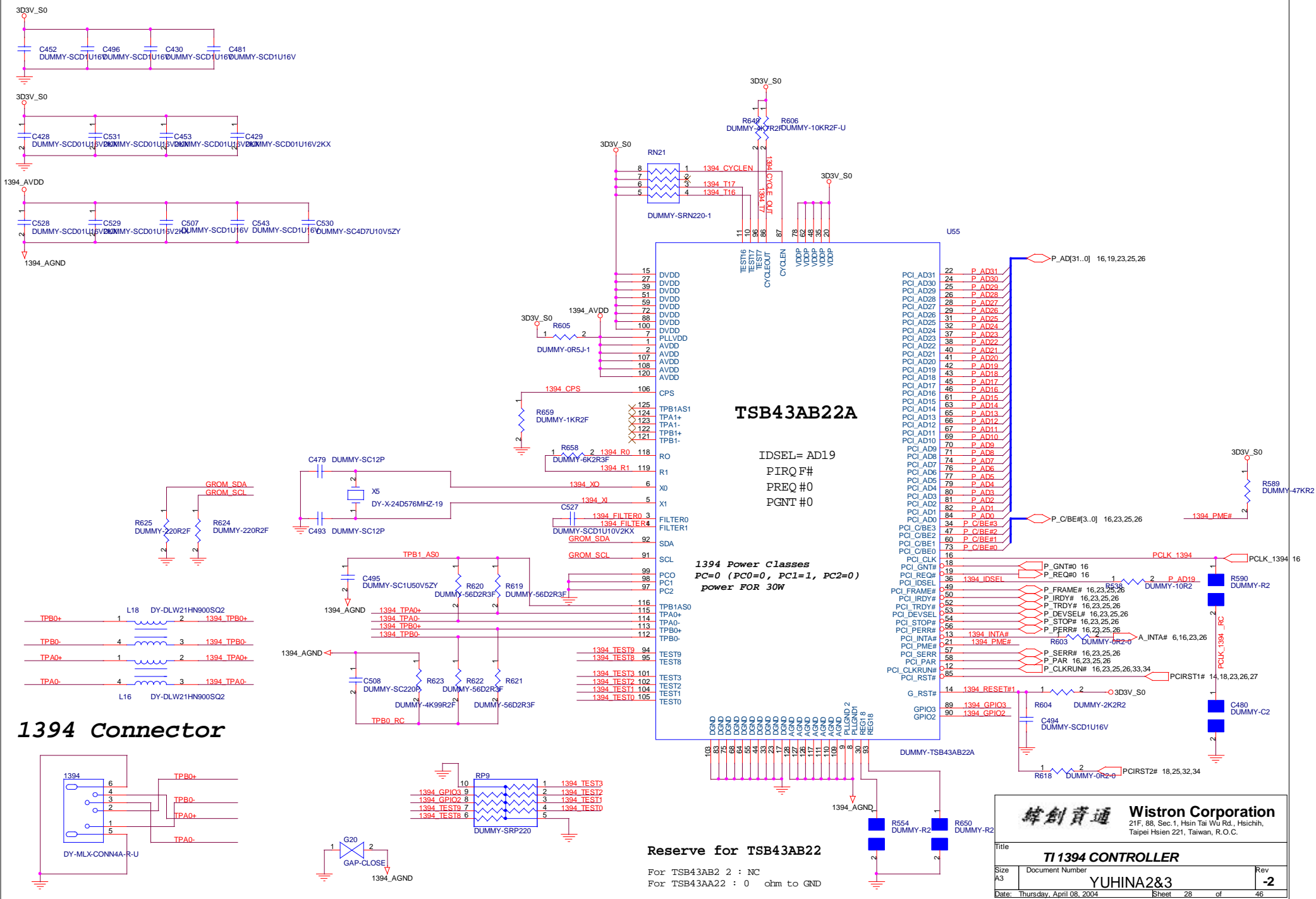

**TSB43AB22A**

IDSEL= AD19  
PIRQ#0  
PREQ#0  
PGNT#0

1394 Power Classes  
PC=0 (PC0=0, PC1=1, PC2=0)  
power FOR 30W

**1394 Connector**

**Reserve for TSB43AB22**

For TSB43AB22 : NC  
For TSB43AA22 : 0 ohm to GND

		<b>Wistron Corporation</b> 21F, 88, Sec.1, Hsin Tai Wu Rd., Hsichih, Taipei Hsien 221, Taiwan, R.O.C.	
<b>TI 1394 CONTROLLER</b>			
Title	Document Number	Rev	
	YUHINA2&3	-2	
Date:	Thursday, April 08, 2004	Sheet	28 of 46

# PRINTER PORT

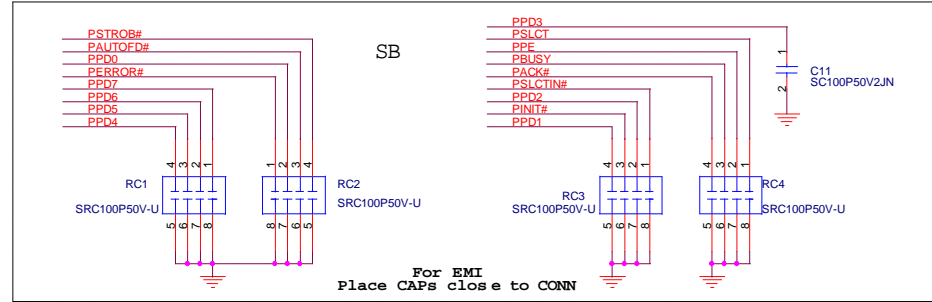
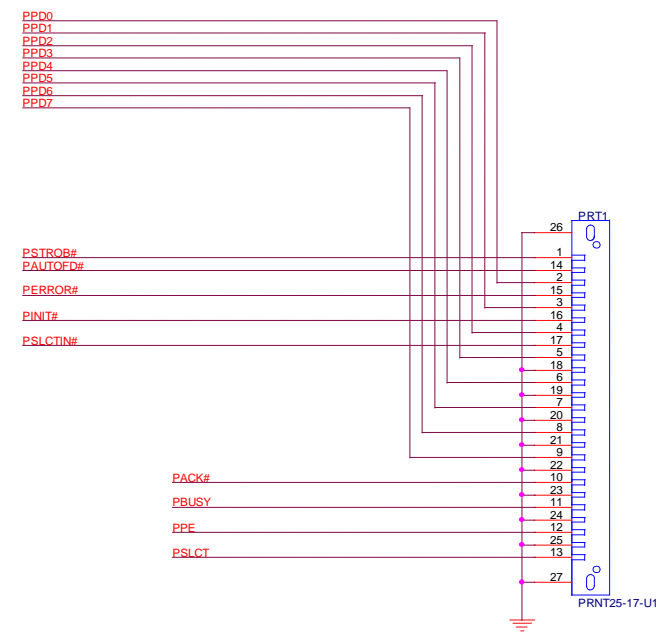
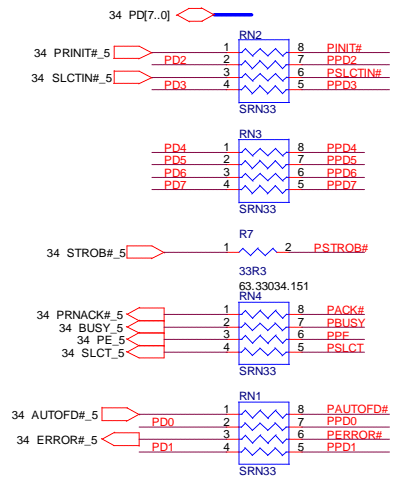
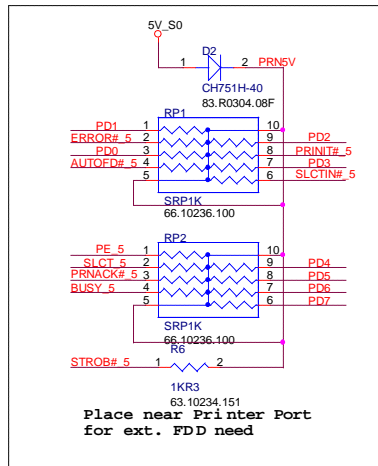

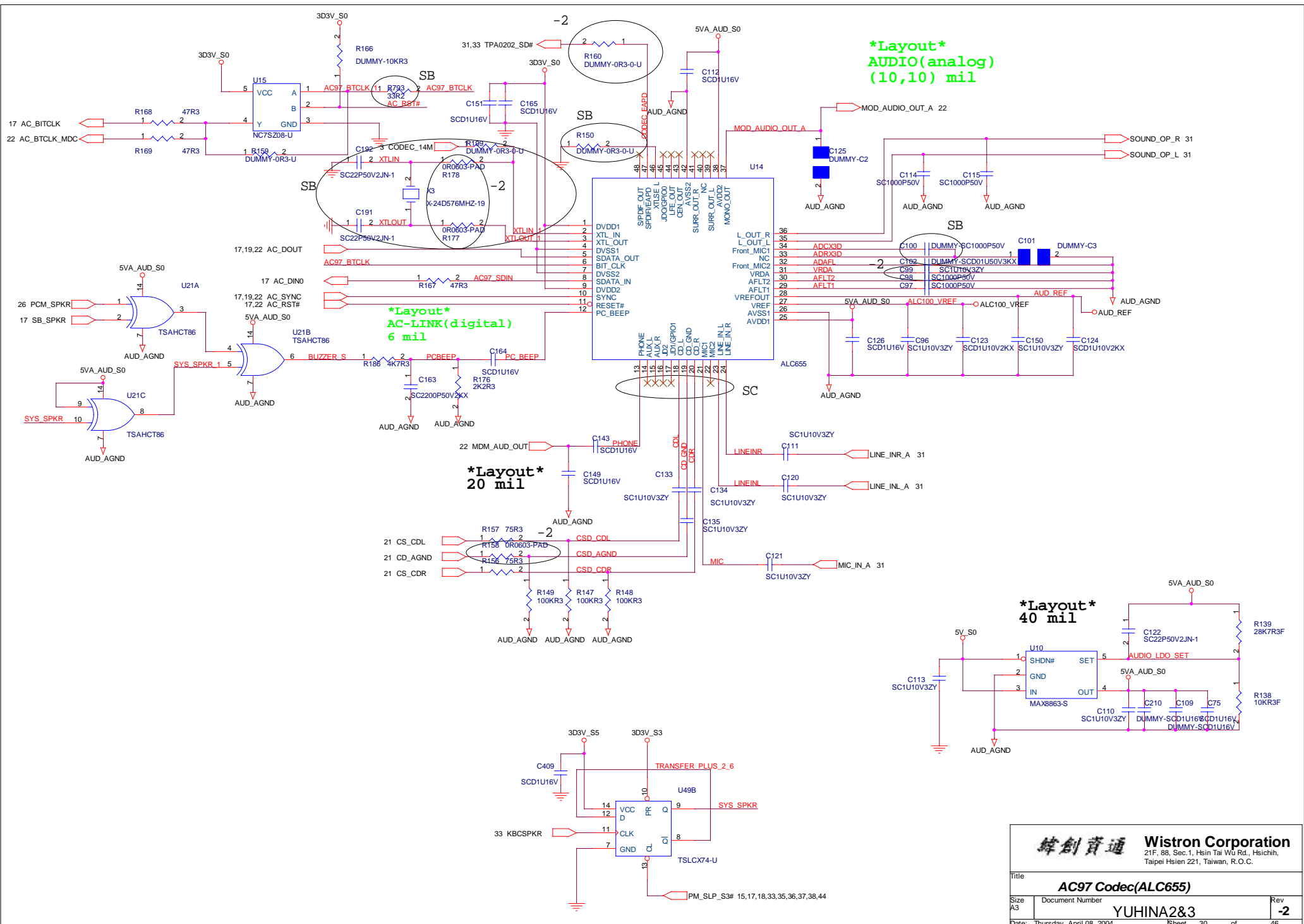

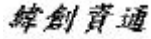
 <b>Wistron Corporation</b> 21F, 88, Sec.1, Hsin Tai Wu Rd., Hsichih, Taipei Hsien 221, Taiwan, R.O.C.	
<b>Title</b> <b>AC97 Codec(ALC655)</b>	
<b>Size</b> A3	<b>Document Number</b> <b>YUHINA2&amp;3</b>
<b>Rev</b> <b>-2</b>	
Date: Thursday, April 08, 2004      Sheet 30 of 46	

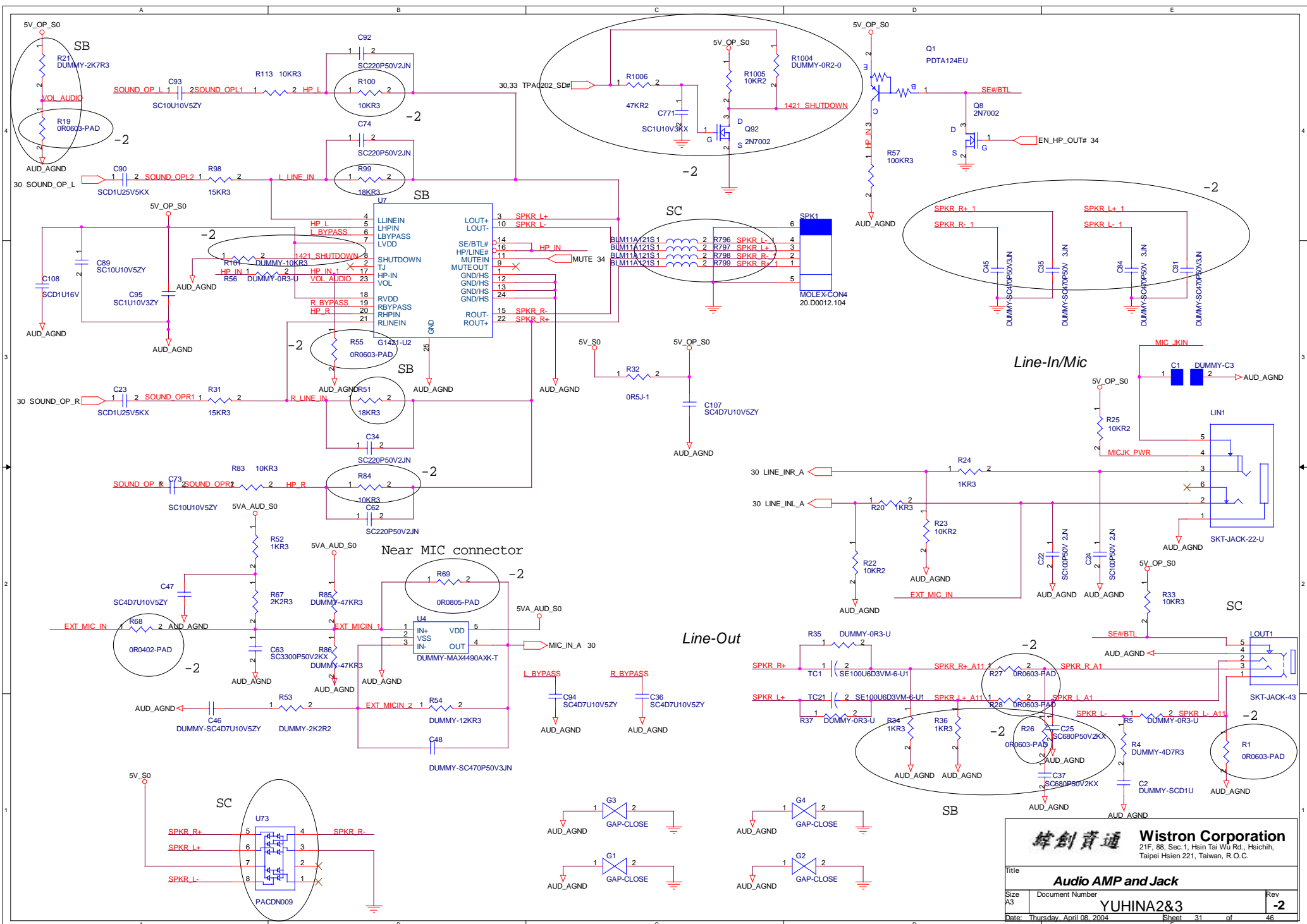

**緯創資通 Wistron Corporation**  
 21F, 88, Sec. 1, Hsin Tai Wu Rd., Hsichih,  
 Taipei Hsien 221, Taiwan, R.O.C.

Title: **Audio AMP and Jack**

Size: A3	Document Number: YUHINA2&3	Rev: -2
Date: Thursday, April 08, 2004		Sheet 31 of 46

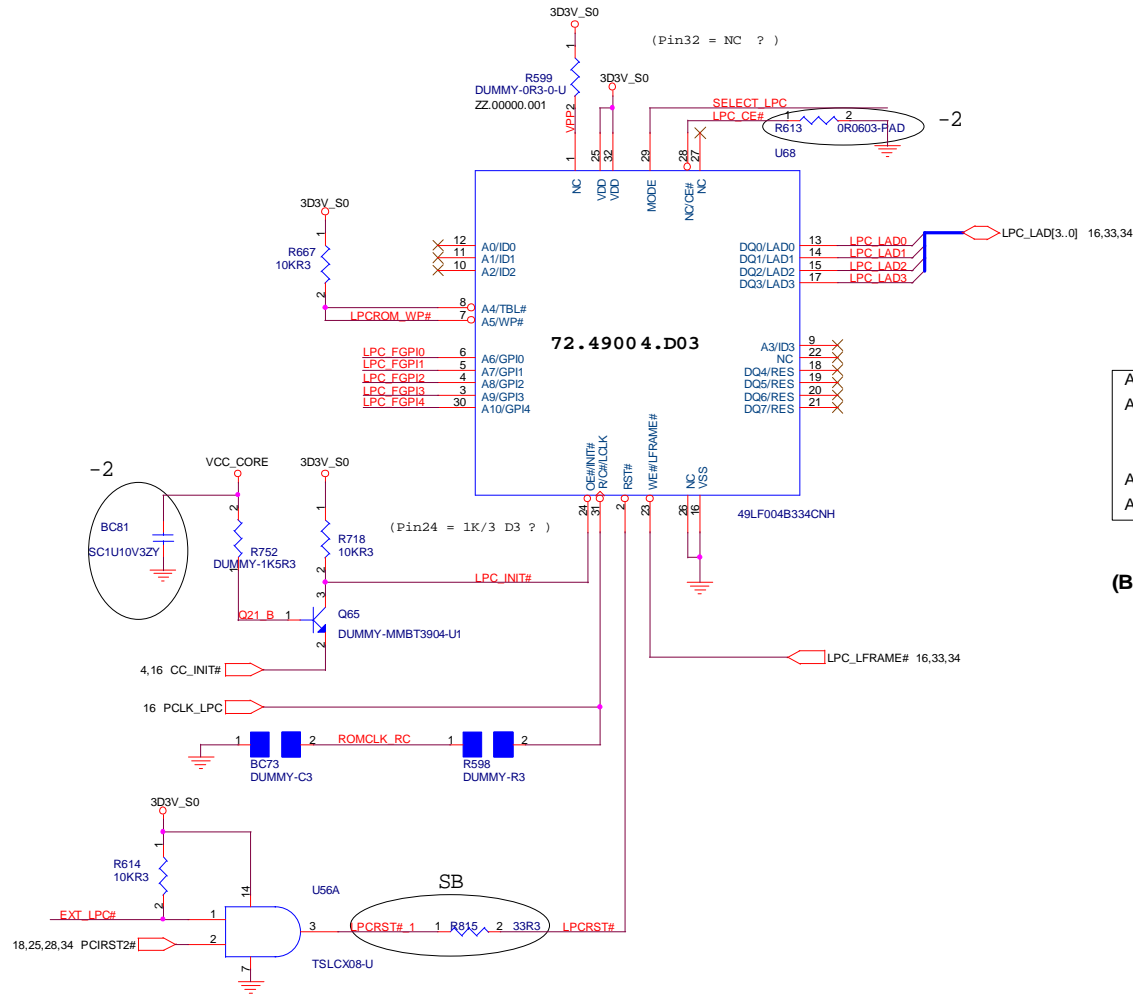
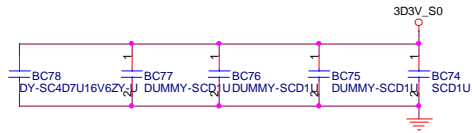
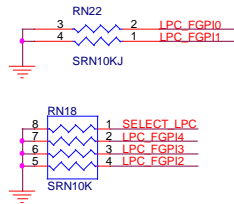

TOP VIEW

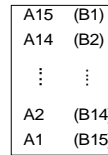

(BOTTOM VIEW)

GOLDEN FINGER FOR DEBUG BOARD

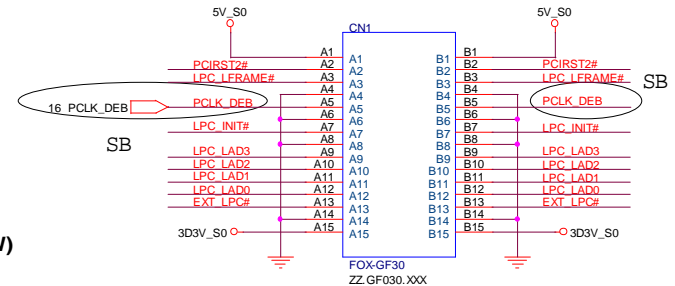

PLCC 32pin ST: 72.50040.003  
 PLCC 32pin SST: 72.49004.B03



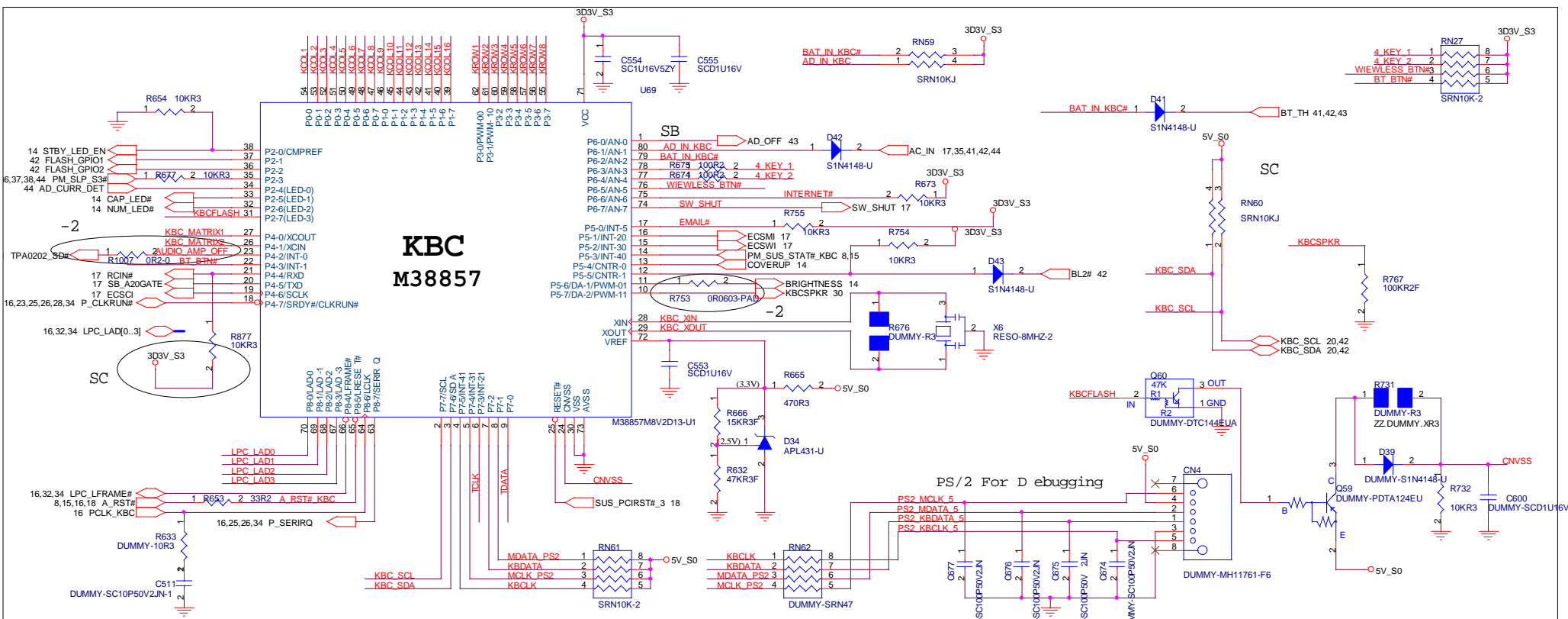

# KBC M38857

## Launch Board Connector

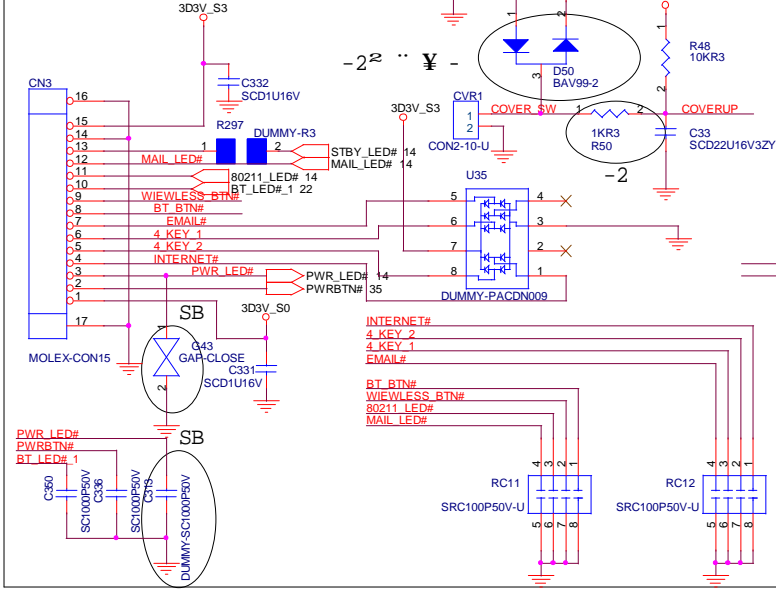

## TouchPad Connector

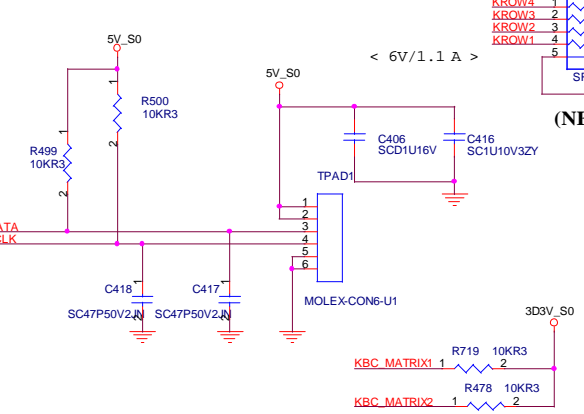

## Internal Keyboard Connector

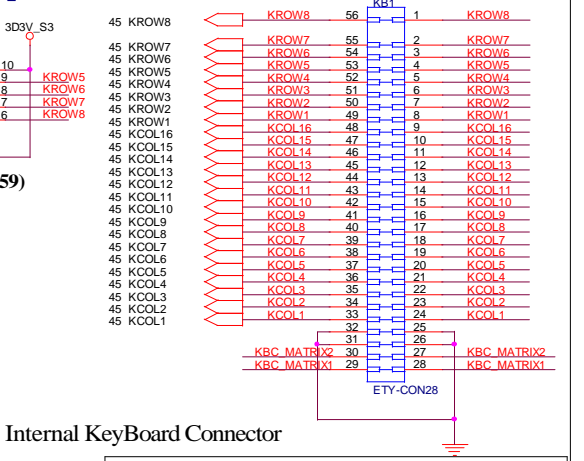

### Keyboard matrix

	US	Europe	Jap	Others
MATRIX1	HIGH	LOW	HIGH	LOW
MATRIX2	HIGH	HIGH	LOW	LOW

緯創資通 **Wistron Corporation**  
 21F, 88, Sec.1, Hsin Tai Wu Rd., Hsichih, Taipei Hsien 221, Taiwan, R.O.C.

Title: **KBC(38857)**

Size: A3 Document Number: **YUHINA2&3** Rev: **-2**

Date: Thursday, April 08, 2004 Sheet: 33 of 46

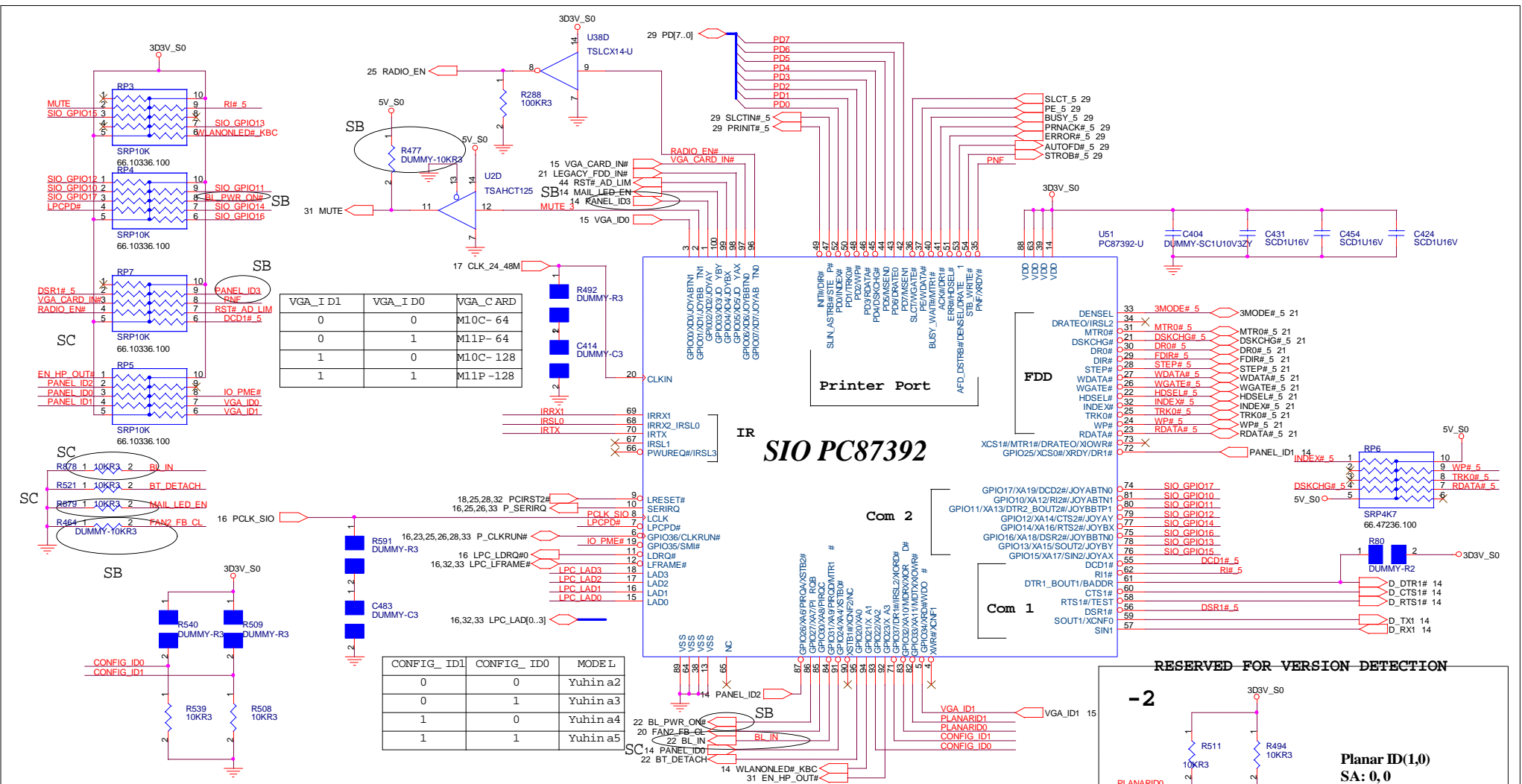

## Infineon FIR Module

Layout Guide:  
(1) FIR\_5V : 30 mils



PANEL_ID3	PANEL_ID2	PANEL_ID1	PANEL_ID0	VENDO RS
0	0	0	0	15" SX GA+
0	0	0	1	Hydis (14") SPWG
0	0	1	0	15" WI DE
0	0	1	1	Hitachi (15")
0	0	1	1	AU (15 ")
0	1	0	0	CMO(15 ")
0	1	0	1	CMO(14 ")
0	1	1	0	AU (14 ")
0	1	1	1	AU (14 ")**
0	1	1	1	No Panel

Note : AU (≠ 1), CMO(⊖ -), \*\*: With Digitizer

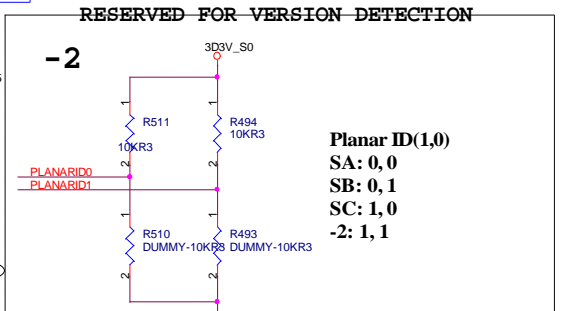

**緯創資通 Wistron Corporation**  
21F, 88, Sec.1, Hsin Tai Wu Rd., Hsichih, Taipei Hsien 221, Taiwan, R.O.C.

Title: **SIO(87392)**

Size: A3  
Document Number: **YUHINA2&3**  
Date: Thursday, April 08, 2004

Rev: **-2**  
Sheet: 34 of 46

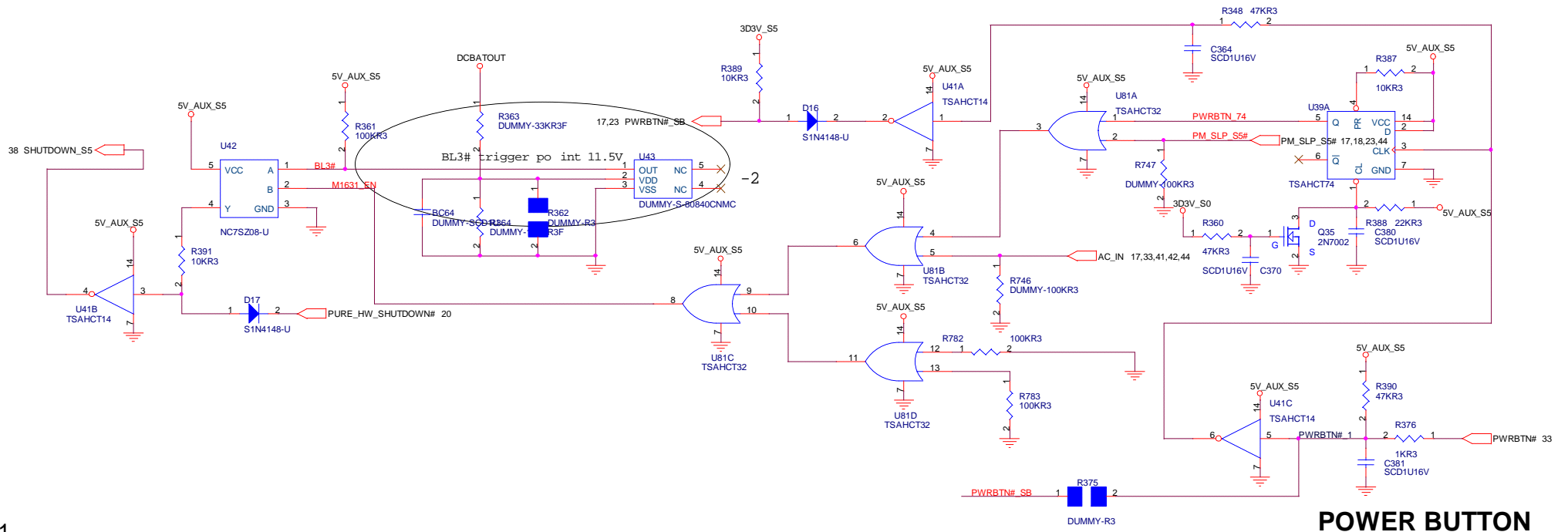

1

1

L4# circuit

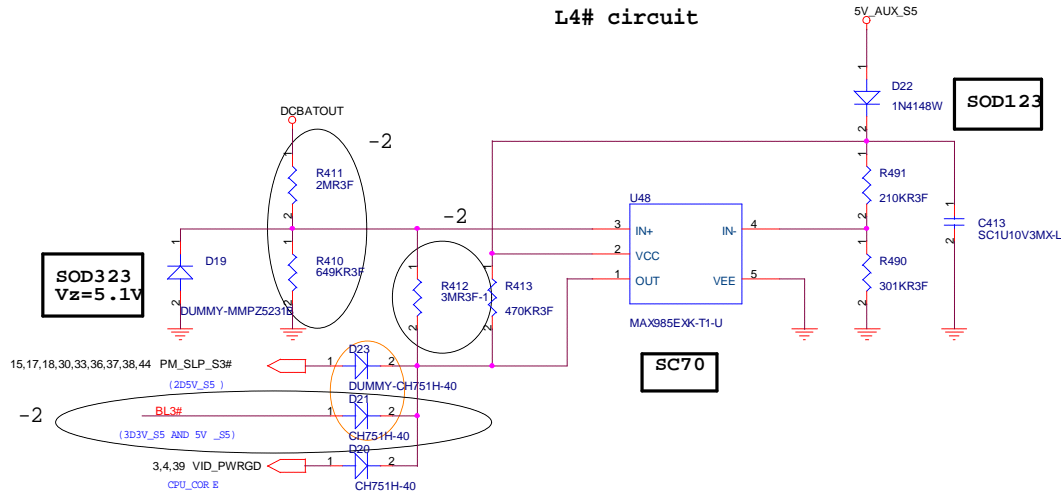

<b>緯創資通 Wistron Corporation</b>		
21F, 88, Sec. 1, Hsin Tai Wu Rd., Hsichih, Taipei Hsien 221, Taiwan, R.O.C.		
Title <b>POWER ON CIRCUIT</b>		
Size A3	Document Number <b>YUHINA2&amp;3</b>	Rev <b>-2</b>
Date: Thursday, April 06, 2004	Sheet 35	of 46

A

B

C

D

E

TOKIN POS-CAP 150U/4V 3.5\*2.8\*1.9  
ESR = 35mohm / Ripple current = 1.558A

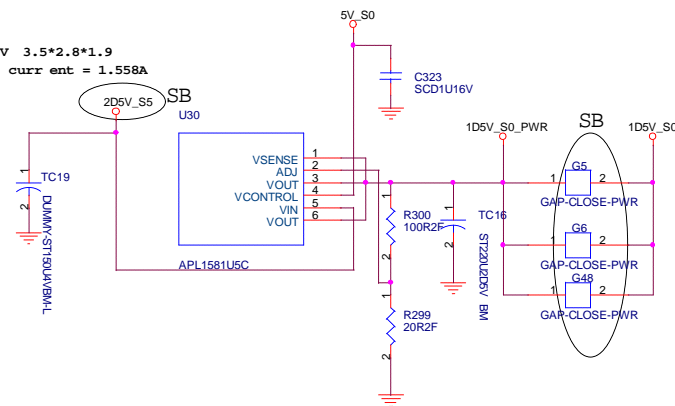

TOKIN POS-CAP 220U/2D5 3.5\*2.8\*1.9  
ESR = 35mohm / Ripple current = 1.558A

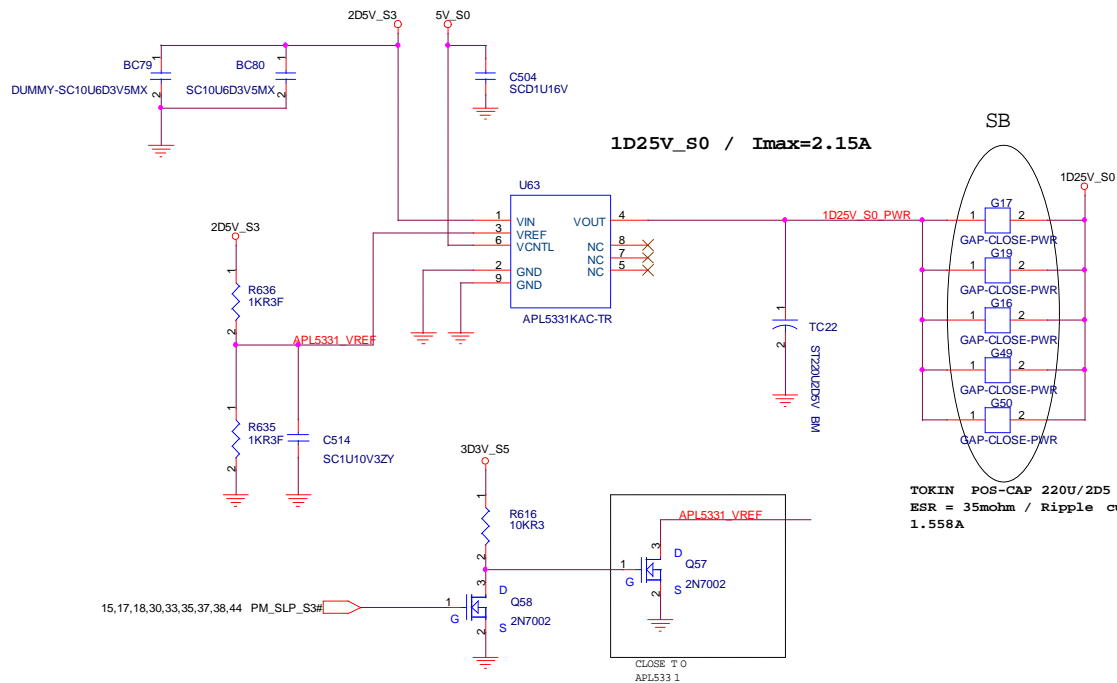

TOKIN POS-CAP 220U/2D5 3.5\*2.8\*1.9  
ESR = 35mohm / Ripple current = 1.558A

緯創資通 Wistron Corporation  
21F, 88, Sec.1, Hsin Tai Wu Rd., Hsichih,  
Taipei Hsien 221, Taiwan, R.O.C.

Title  
**1D25V\_S0\_APL5331 / 1D5V\_S0\_APL1581/L4**

Size A3 Document Number YUHINA2&3 Rev -2

Date: Thursday, April 08, 2004 Sheet 36 of 46

A

B

C

D

E

# TI TPS5110 for 2.5V and 1.8V

CT = 47pF/300KHz  
 2D5V\_S5: 1.2.6Amax , OCP > 16.3A  
 1D8V\_S0: 0.837Amax , OCP > 1A

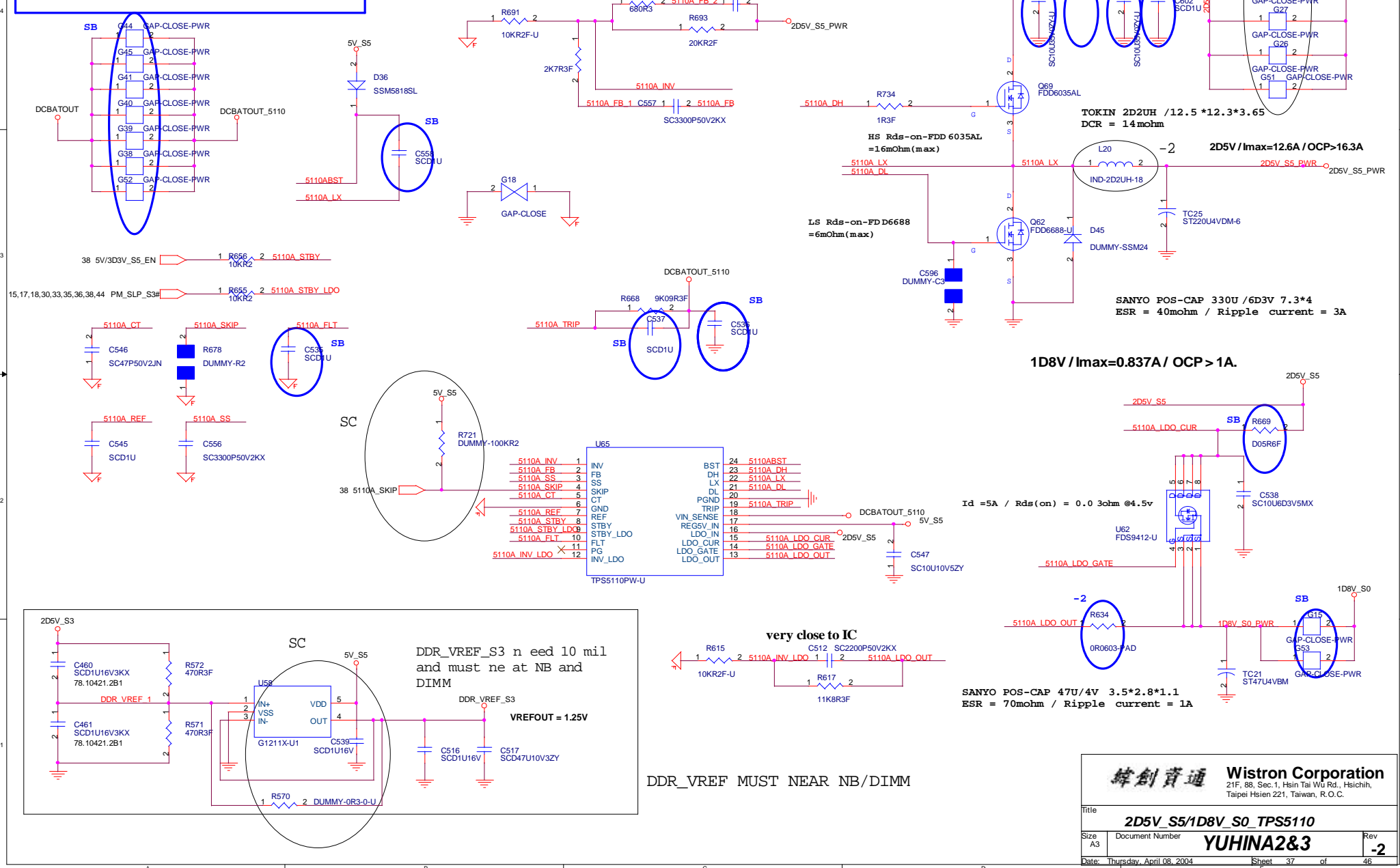

**緯創資通 Wistron Corporation**  
 21F, 88, Sec. 1, Hsin Tai Wu Rd., Hsichih,  
 Taipei Hsien 221, Taiwan, R.O.C.

Title: **2D5V\_S5/1D8V\_S0\_TPS5110**

Size A3 Document Number **YUHINA2&3** Rev **-2**

Date: Thursday, April 08, 2004 Sheet 37 of 46

# TI TPS51020 for 5V and 3D3V

**SSTRT2 & SSTRT1 = 1M ohm / 270KHz**  
**5V\_S0 : 8.625Amax , OCP > 11.2A**  
**3D3V\_S5 : 5.452Amax , OCP > 7.6A**

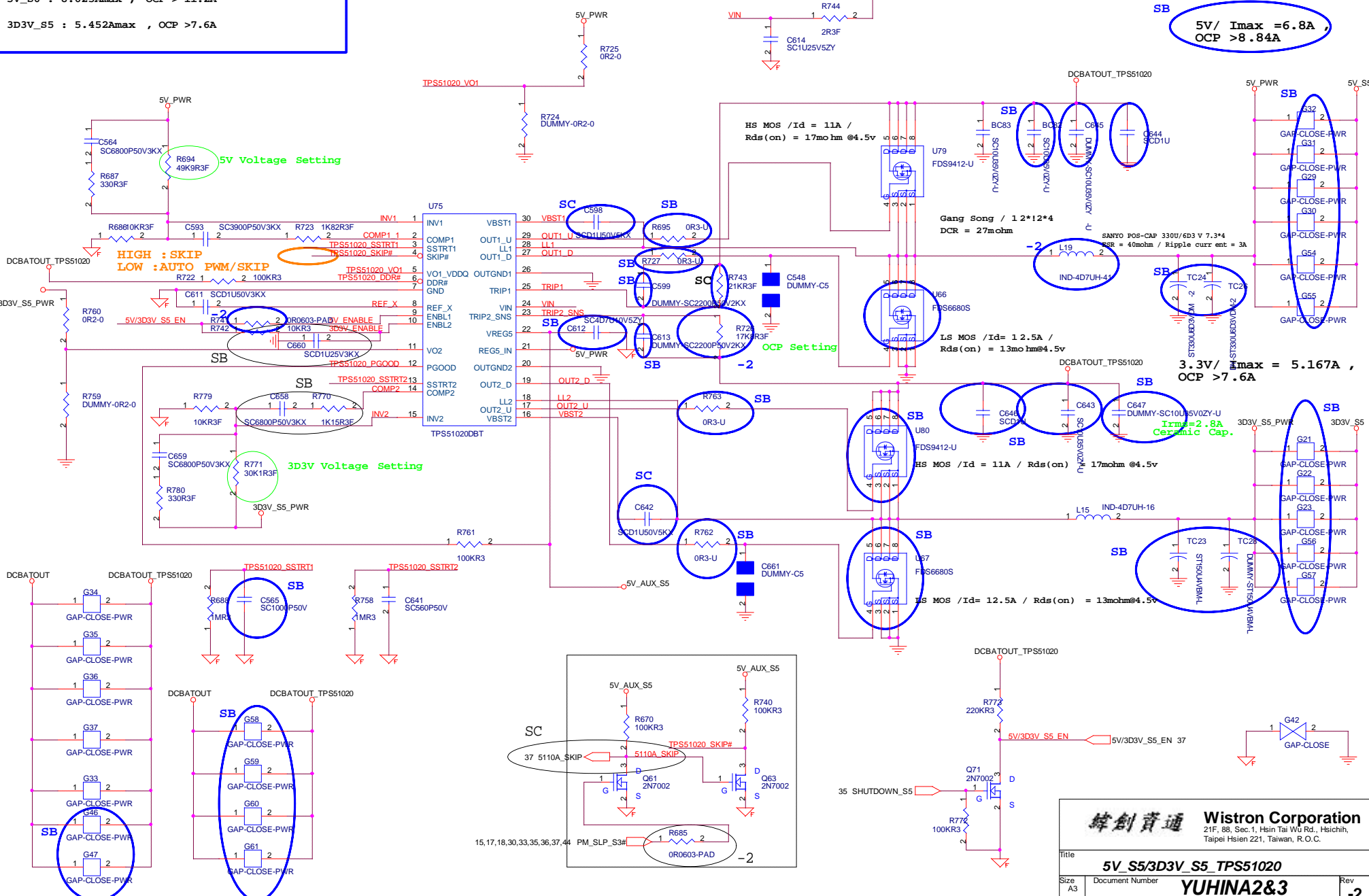

**緯創資通 Wistron Corporation**  
 21F, 88, Sec. 1, Hsin Tai Wu Rd., Hsichih,  
 Taipei Hsien 221, Taiwan, R.O.C.

Title		
5V_S5/3D3V_S5_TPS51020		
Size	Document Number	Rev
A3	YUHINA2&3	-2
Date: Thursday, April 08, 2004	Sheet 38 of 46	

CPU\_Vcore IMVP5\_FMB1(1/2)

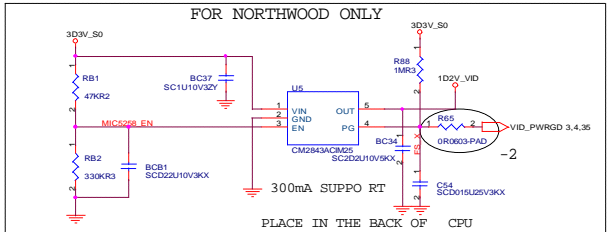
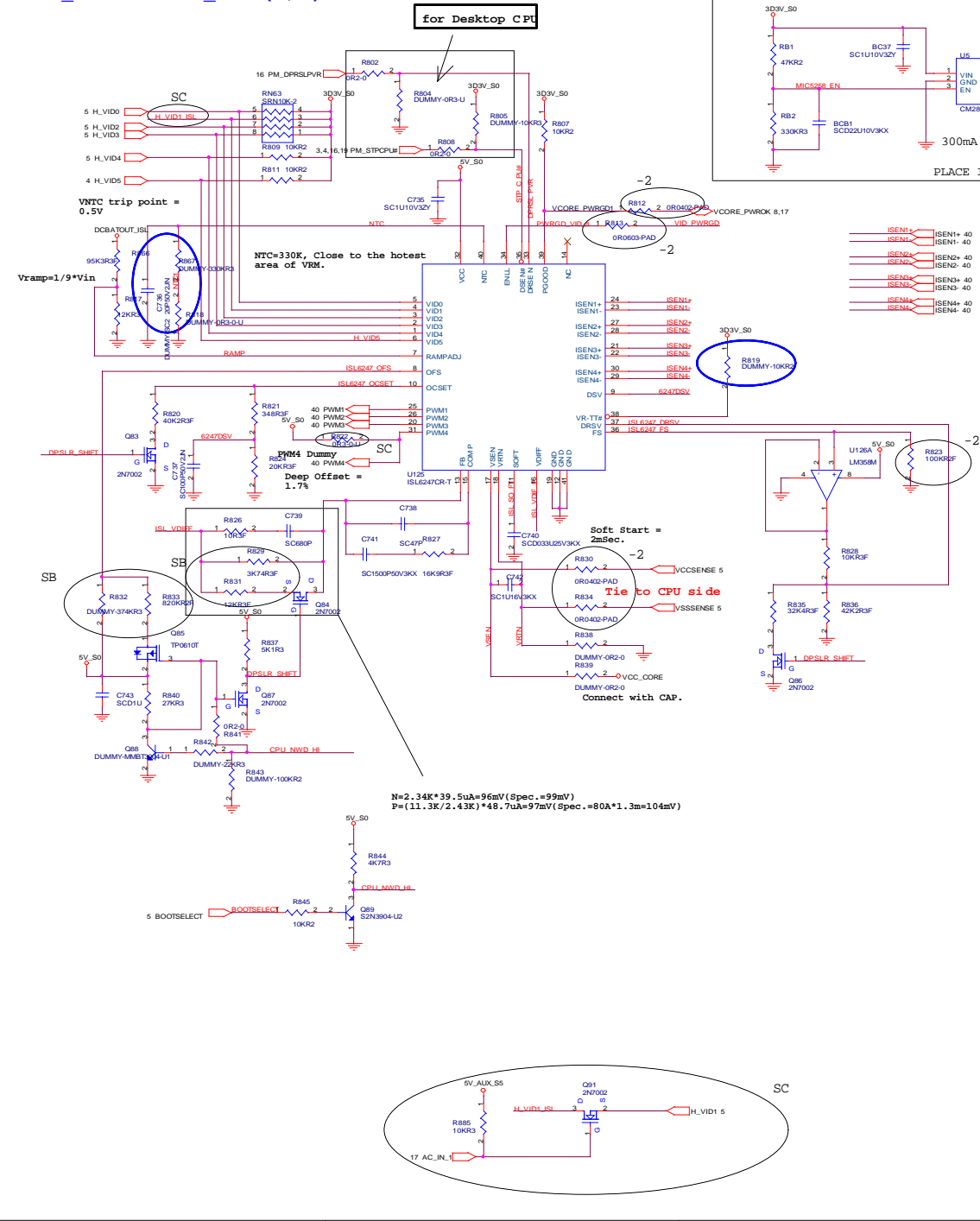

Voltage Identification Codes

VID5	VID4	VID3	VID2	VID1	VID0	VDAC
X	1	1	1	1	1	OFF
0	0	1	0	1	0	0.8375
1	0	1	0	0	1	0.8500
0	0	1	0	0	1	0.8625
1	0	1	0	0	0	0.8750
0	0	1	0	0	0	0.8875
1	0	0	1	1	1	0.9000
0	0	0	1	1	1	0.9125
1	0	0	1	1	0	0.9250
0	0	0	1	1	0	0.9375
1	0	0	1	0	1	0.9500
0	0	0	1	0	1	0.9625
1	0	0	1	0	0	0.9750
0	0	0	1	0	0	0.9875
1	0	0	0	1	1	1.0000
0	0	0	0	1	1	1.0125
1	0	0	0	1	0	1.0250
0	0	0	0	1	0	1.0375
1	0	0	0	0	1	1.0500
0	0	0	0	0	1	1.0625
1	0	0	0	0	0	1.0750
0	0	0	0	0	0	1.0875
1	1	1	1	1	1	1.1000
0	1	1	1	1	0	1.1125
1	1	1	1	0	1	1.1250
0	1	1	1	0	1	1.1375
1	1	1	1	0	0	1.1500
0	1	1	1	0	0	1.1625
1	1	1	0	1	1	1.1750
0	1	1	0	1	1	1.1875
1	1	1	0	1	0	1.2000
0	1	1	0	1	0	1.2125
1	1	1	0	0	1	1.2250
0	1	1	1	1	1	1.2375
1	1	1	0	0	0	1.2500
0	1	1	0	0	0	1.2625
1	1	0	1	1	1	1.2750
0	1	0	1	1	1	1.2875
1	1	0	1	1	0	1.3000
0	1	0	1	1	0	1.3125
1	1	0	1	0	1	1.3250
0	1	0	1	0	1	1.3375
1	1	0	1	0	0	1.3500
0	1	0	1	0	0	1.3625
1	1	0	0	1	1	1.3750
0	1	0	0	1	1	1.3875
1	1	0	0	1	0	1.4000
0	1	0	0	1	0	1.4125
1	1	0	0	0	1	1.4250
0	1	0	0	0	1	1.4375
1	1	0	0	0	0	1.4500
0	1	0	0	0	0	1.4625
1	0	1	1	1	1	1.4750

Voltage Identification Codes

VID5	VID4	VID3	VID2	VID1	VID0	VDAC
0	1	1	1	1	1	1.4875
0	1	1	1	1	0	1.5000
0	1	1	1	1	0	1.5125
0	1	1	0	1	1	1.5250
0	1	1	0	1	1	1.5375
0	1	1	0	0	1	1.5500
0	1	1	0	0	0	1.5625
0	1	0	1	1	1	1.5750
0	1	0	1	1	1	1.5875
0	1	0	1	0	1	1.6000

CPU\_Vcore IMVP5\_FMB1(2/2)

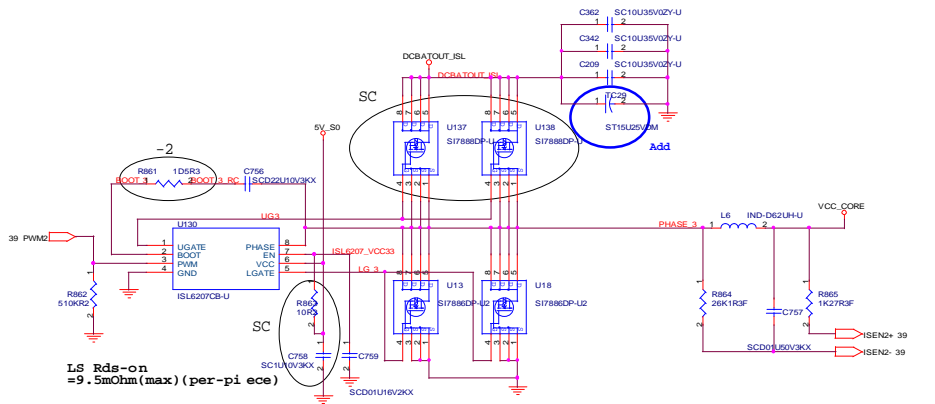
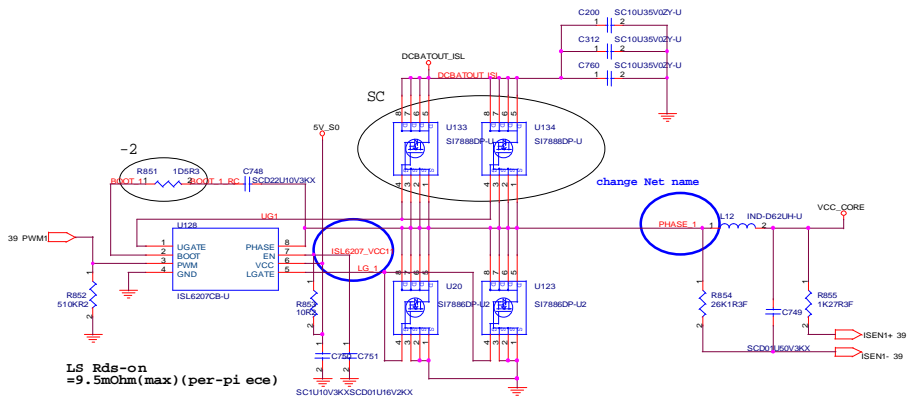
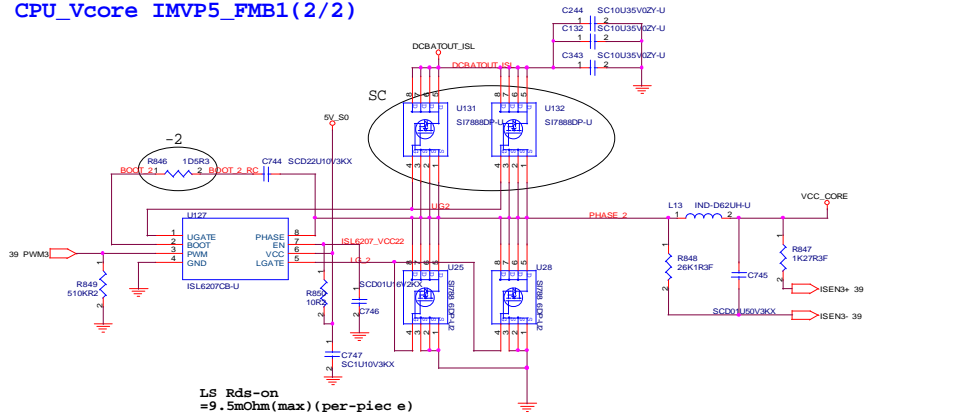

PLACE IN THE BACK OF CPU, ESR < (TED)mOhm,

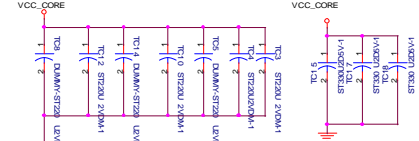

PANASONIC/ 330U2V 7.3\*4.3\*1.9  
ESR=9mohm / ripple current  
=3A

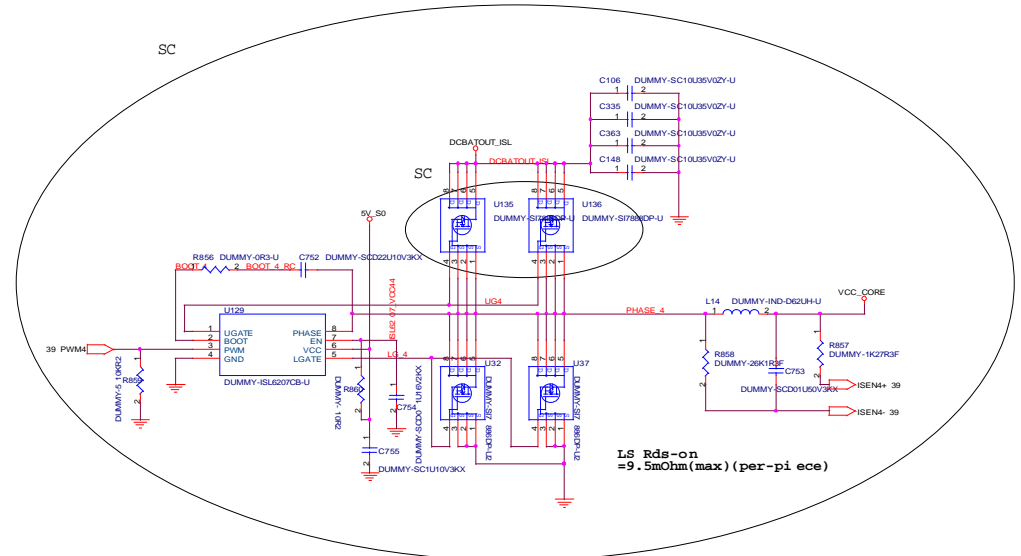
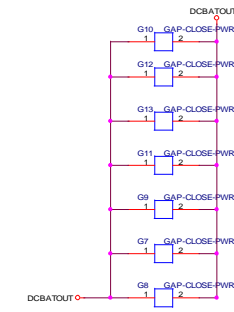



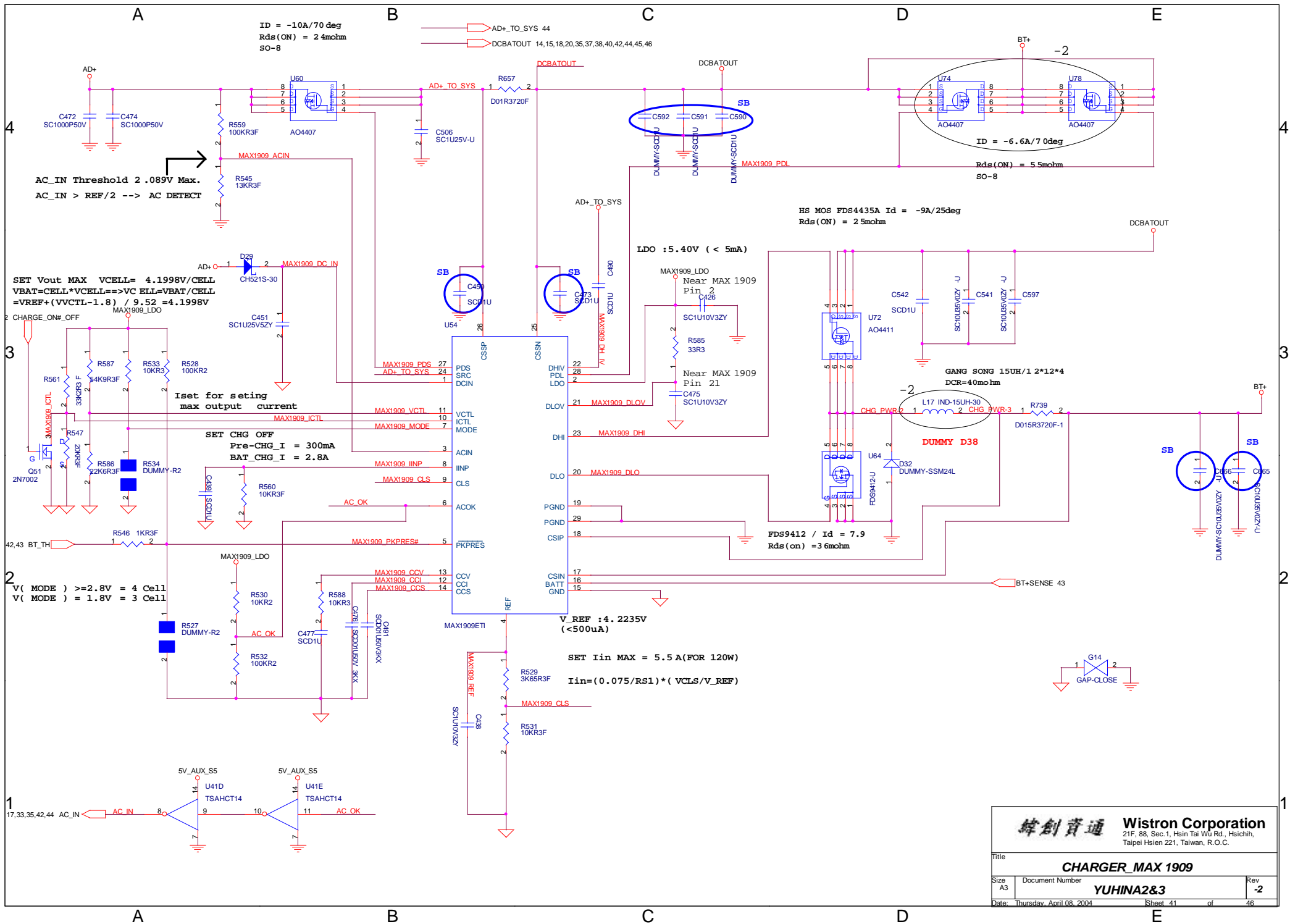

ID = -10A/70 deg  
 Rds(ON) = 2.4mohm  
 SO-8

ID = -6.6A/70 deg  
 Rds(ON) = 5.5mohm  
 SO-8

HS MOS FDS4435A Id = -9A/25deg  
 Rds(ON) = 2.5mohm

FDS9412 / Id = 7.9  
 Rds(on) = 3.6mohm

LDO : 5.40V (< 5mA)

V\_REF : 4.2235V (<500uA)

SET Iin MAX = 5.5 A(FOR 120W)  
 $I_{in} = (0.075/RS1) * (V_{CLS}/V_{REF})$

AC\_IN Threshold 2.089V Max.  
 AC\_IN > REF/2 --> AC DETECT

SET Vout MAX VCELL = 4.1998V/CELL  
 VBAT = CELL \* VCELL ==> VCELL = VBAT / CELL  
 = VREF + (VVTCL - 1.8) / 9.52 = 4.1998V

Iset for setting max output current

SET CHG OFF Pre-CHG\_I = 300mA  
 BAT-CHG\_I = 2.8A

V(MODE) >= 2.8V = 4 Cell  
 V(MODE) = 1.8V = 3 Cell

<b>Wistron Corporation</b> 21F, 88, Sec.1, Hsin Tai Wu Rd., Hsichih, Taipei Hsien 221, Taiwan, R.O.C.	
<b>CHARGER MAX 1909</b>	
Size A3	Document Number <b>YUHINA2&amp;3</b>
Rev -2	
Date: Thursday, April 08, 2004	
Sheet 41 of 46	

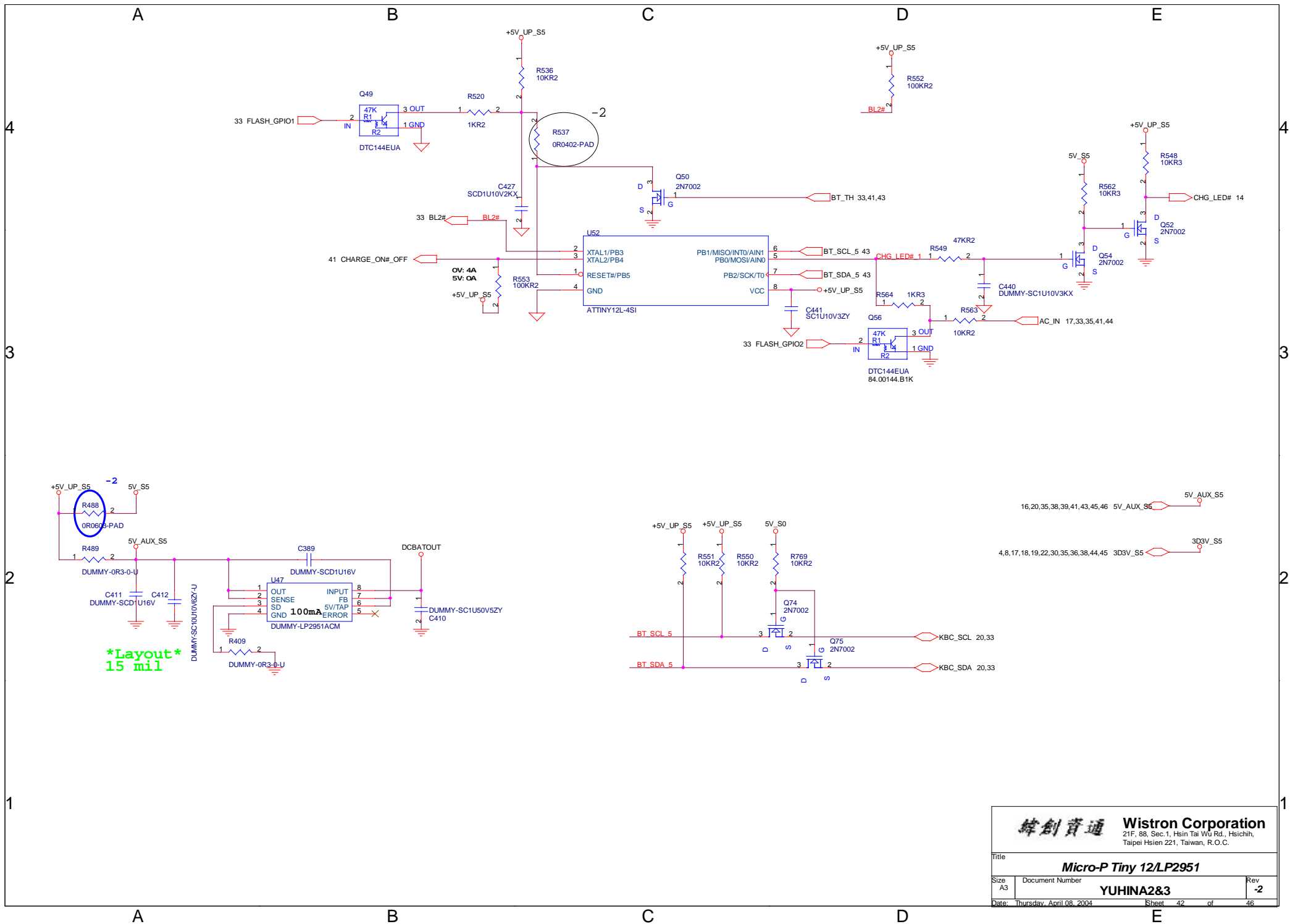

緯創資通 Wistron Corporation  
 21F, 88, Sec.1, Hsin Tai Wu Rd., Hsichih,  
 Taipei Hsien 221, Taiwan, R.O.C.

Title		
Micro-P Tiny 12/LP2951		
Size	Document Number	Rev
A3	YUHINA2&3	-2
Date: Thursday, April 08, 2004		Sheet 42 of 46

# Adaptor in to generate DCBATOUT

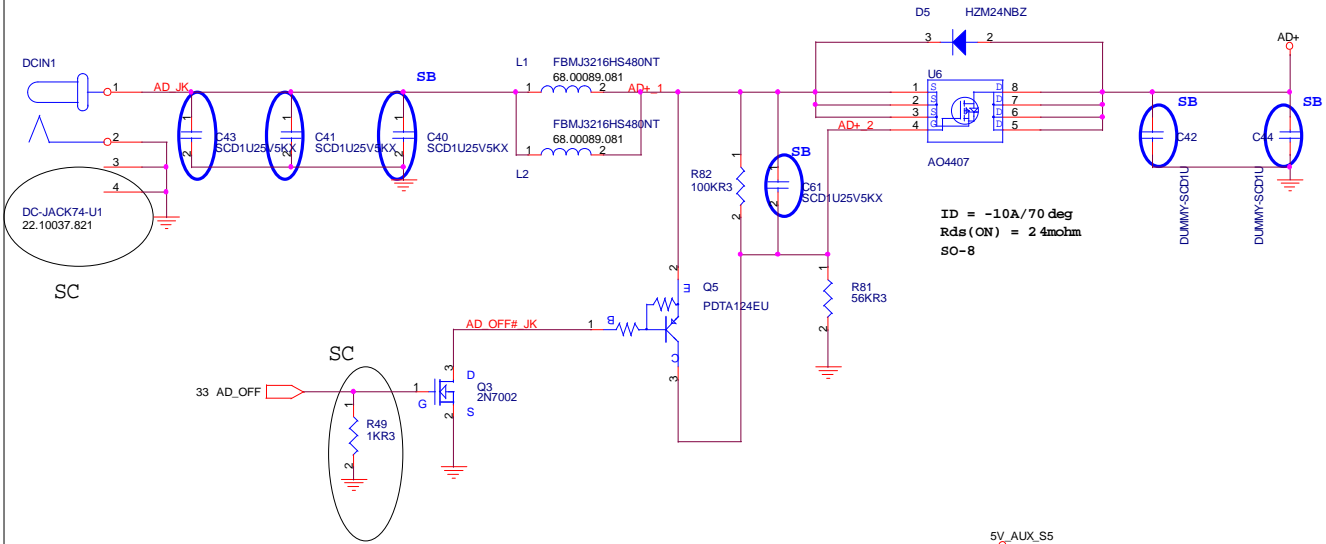

# BATTERY CONNECTOR

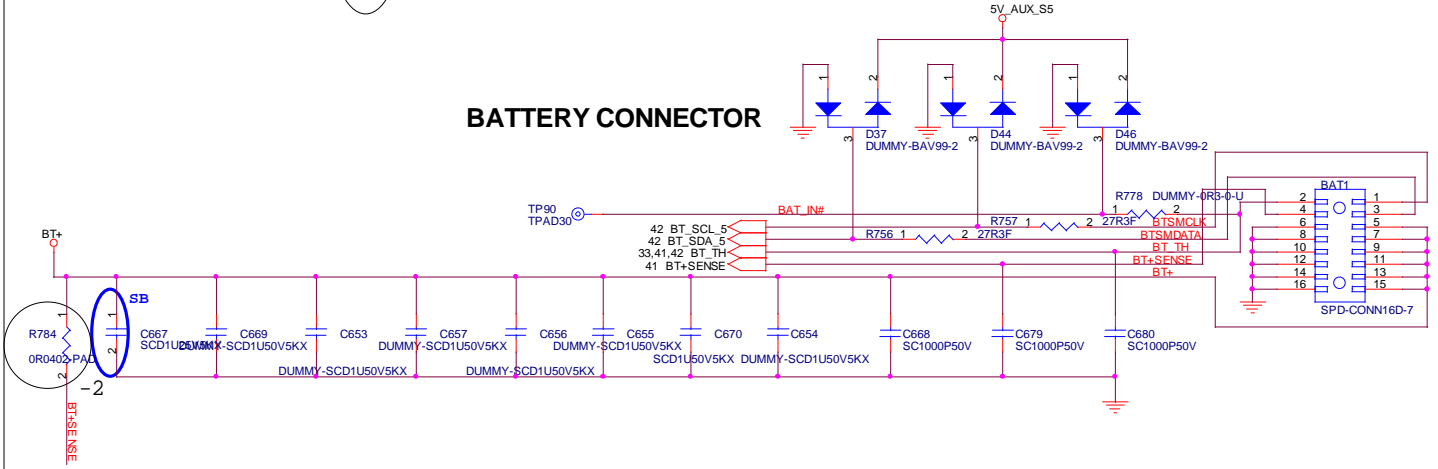

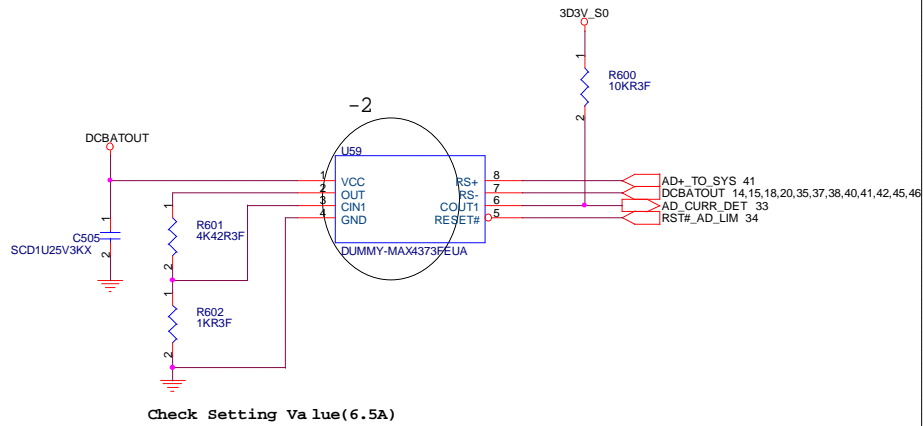

## LAN Power

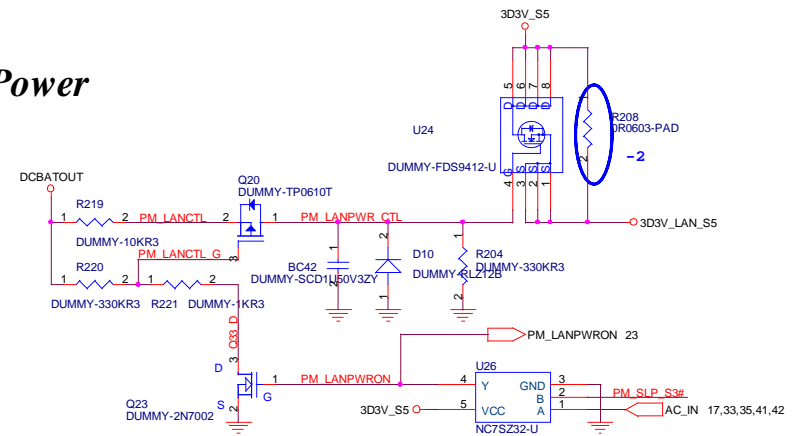

## Run Power

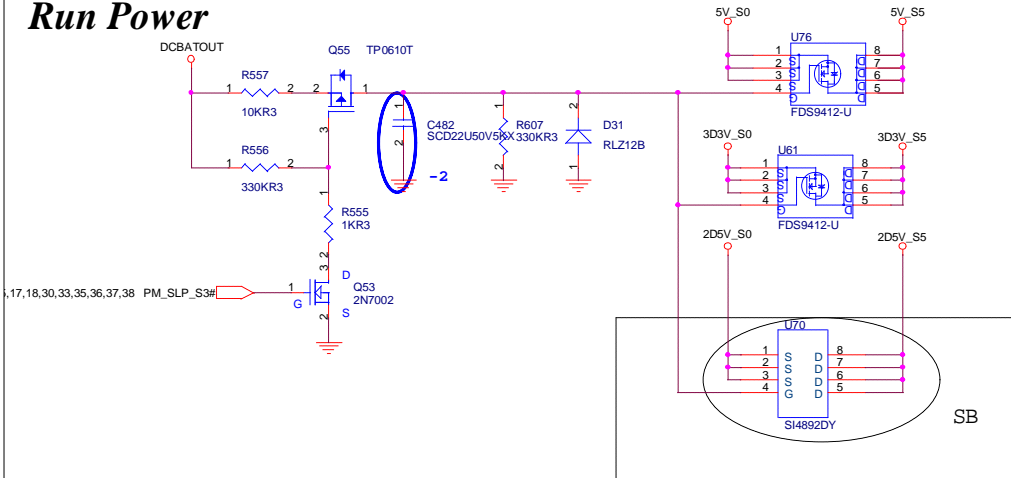

## Suspend Power

Support standby wakeup LAN only

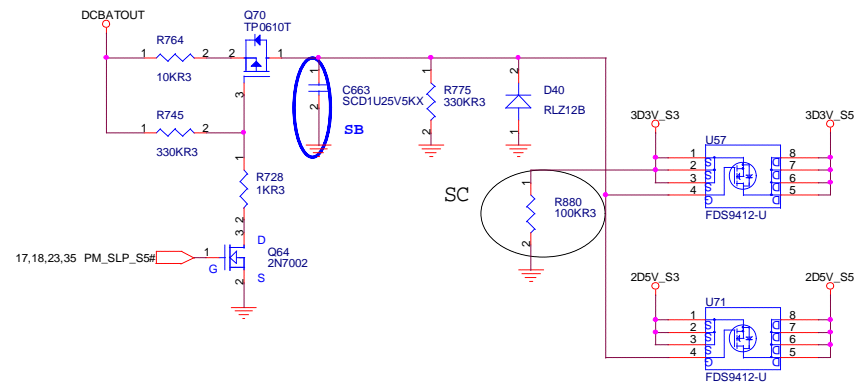

緯創資通 **Wistron Corporation**  
21F, 88, Sec.1, Hsin Tai Wu Rd., Hsichih,  
Taipei Hsien 221, Taiwan, R.O.C.

Title		
<b>PWRPLANE&amp;RESETLOGIC</b>		
Size	Document Number	Rev
A3	<b>YUHINA2&amp;3</b>	<b>-2</b>
Date:	Thursday, April 08, 2004	Sheet 44 of 46

33 KROW8  
33 KROW7  
33 KROW6  
33 KROW5  
33 KROW4  
33 KROW3  
33 KROW2  
33 KROW1  
33 KCOL16  
33 KCOL15  
33 KCOL14  
33 KCOL13

33 KCOL12  
33 KCOL11  
33 KCOL10  
33 KCOL9  
33 KCOL8  
33 KCOL7  
33 KCOL6  
33 KCOL5  
33 KCOL4  
33 KCOL3  
33 KCOL2  
33 KCOL1

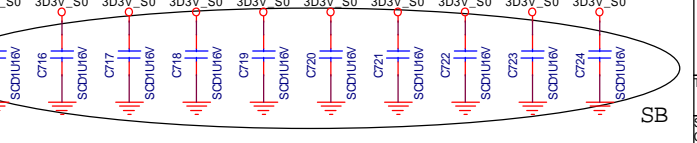
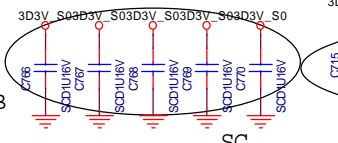
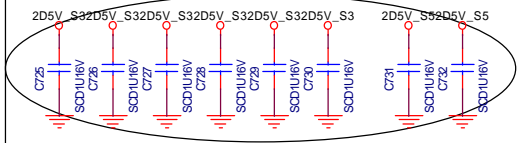
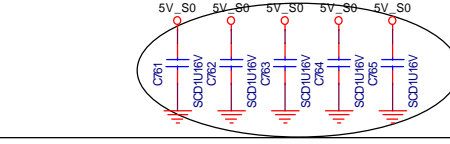
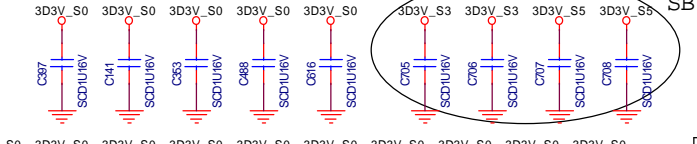
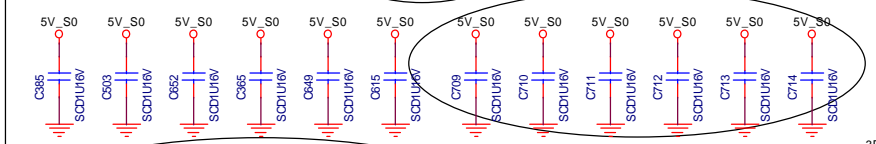
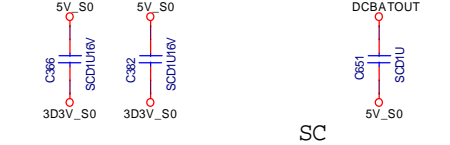
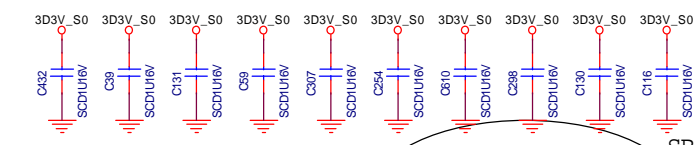
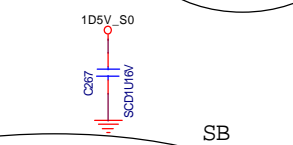
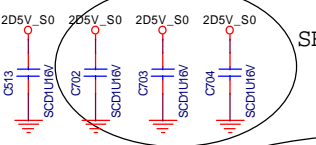
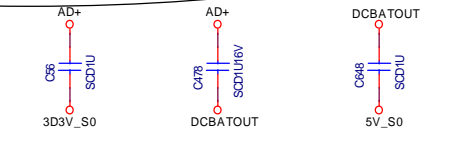
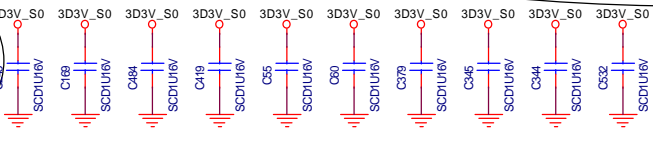
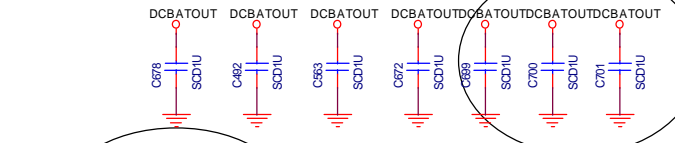
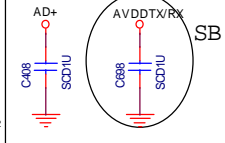
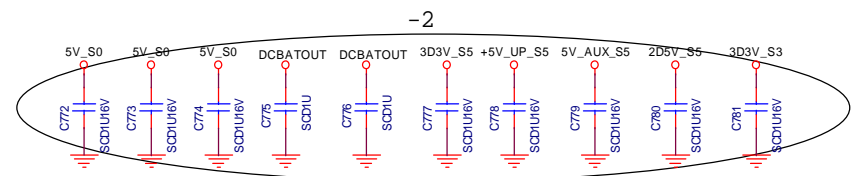
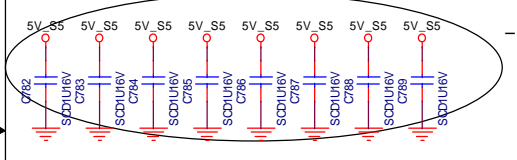
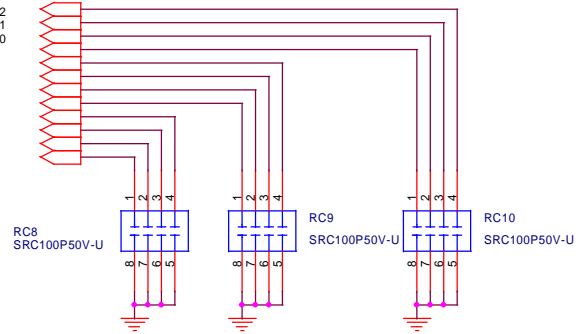
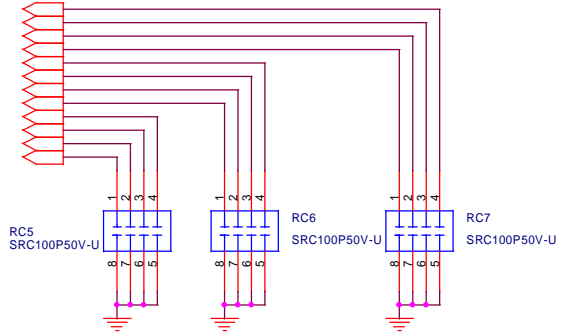

**緯創資通 Wistron Corporation**  
21F, 88, Sec. 1, Hsin Tai Wu Rd., Hsichih,  
Taipei Hsien 221, Taiwan, R. O. C.

Title		EM I	
Size	Document Number	Rev	
Custom	<b>YUHINA2&amp;3</b>	-2	
Date	Thursday, April 08, 2004	Sheet	45 of 46

NO USE LOGIC

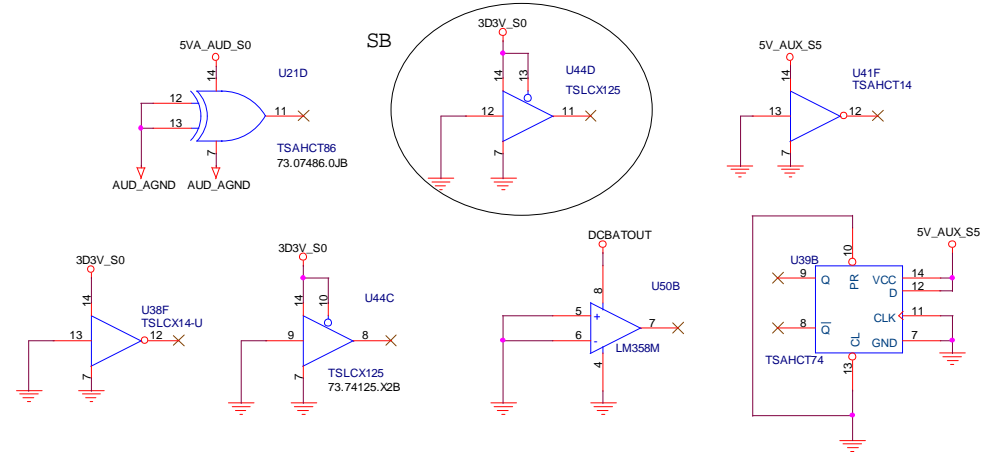

SB α | - » α ∩

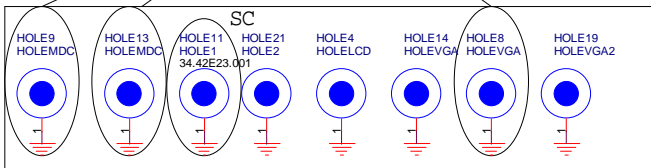

SPARE GATES

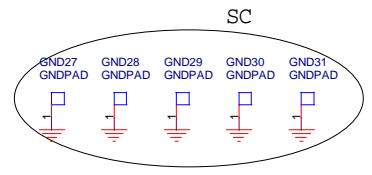
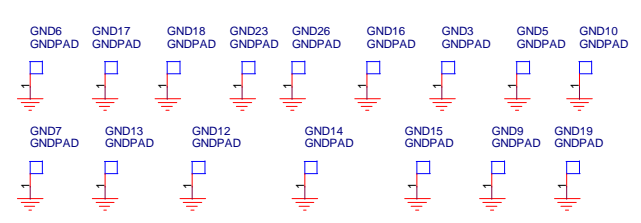
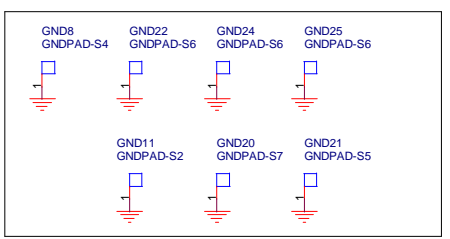
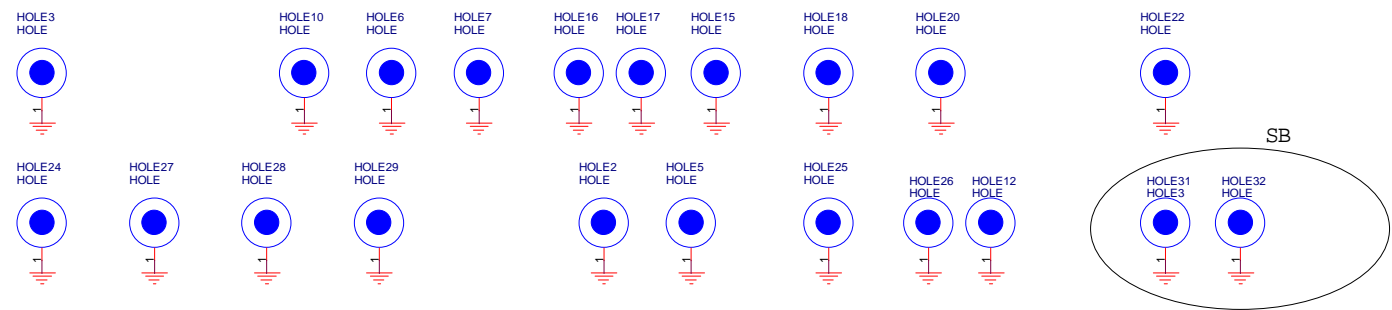

<p>緯創資通 <b>Wistron Corporation</b>                  21F, 88, Sec.1, Hsin Tai Wu Rd., Hsichih,                  Taipei Hsien 221, Taiwan, R.O.C.</p>	
<p>Title: <b>MISC</b></p>	
<p>Size: A3</p>	<p>Document Number: <b>YUHINA2&amp;3</b></p>
<p>Date: Thursday, April 08, 2004</p>	<p>Rev: <b>-2</b></p>