

**SAMSUNG**

# GSM TELEPHONE

## GT-S8500

# **SERVICE** *Manual*

## GSM TELEPHONE



## CONTENTS

1. Safety Precautions
2. Specification
3. Product Function
4. Exploded View and Parts list
5. MAIN Electrical Parts List
6. Level 1 Repair
7. Level 2 Repair
8. Level 3 Repair
9. Reference data

**SAMSUNG  
ELECTRONICS**



GSPN (Global Service Partner Network)

<b>Country</b>	<b>Web Site</b>
North America	<a href="http://service.samsungportal.com">service.samsungportal.com</a>
Latin America	<a href="http://latin.samsungportal.com">latin.samsungportal.com</a>
CIS	<a href="http://cis.samsungportal.com">cis.samsungportal.com</a>
Europe	<a href="http://europe.samsungportal.com">europe.samsungportal.com</a>
China	<a href="http://china.samsungportal.com">china.samsungportal.com</a>
Asia	<a href="http://asia.samsungportal.com">asia.samsungportal.com</a>
Mideast & Africa	<a href="http://mea.samsungportal.com">mea.samsungportal.com</a>

# 7. Level 2 Repair

## 7-1. Assembly

1

assemble CONN.

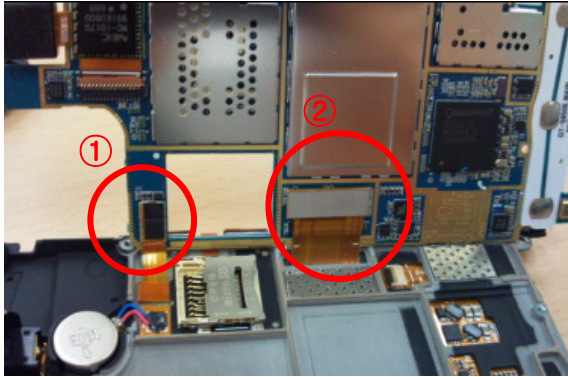

Assemble FPCB not to get loose

2

Screw PBA

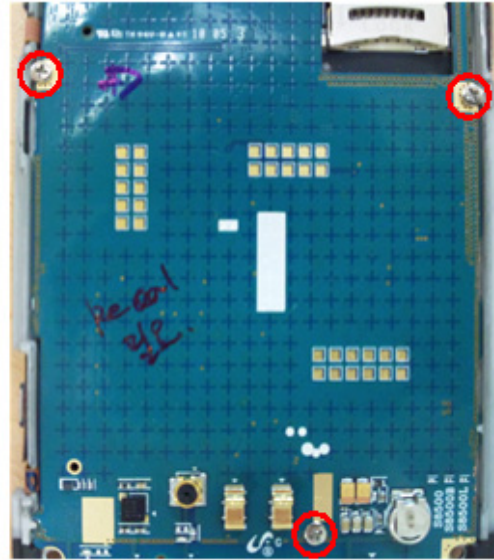

Screw PBA 3-point after Land PBA

3

Assemble FPCB

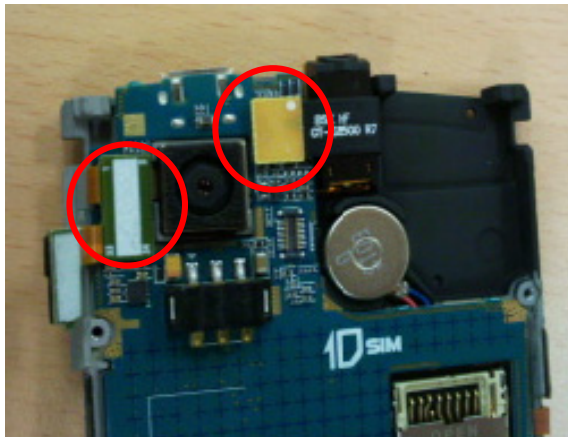

Assemble FPCB not to get loose

4

Assemble Camera FPCB

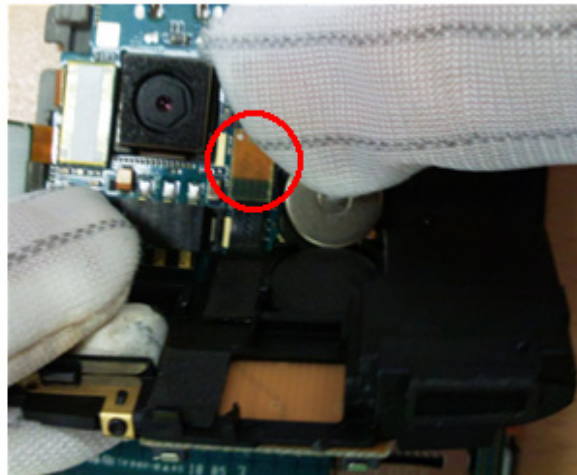

Assemble FPCB not to get loose

7. Level 2 Repair

5

Assemble speaker module

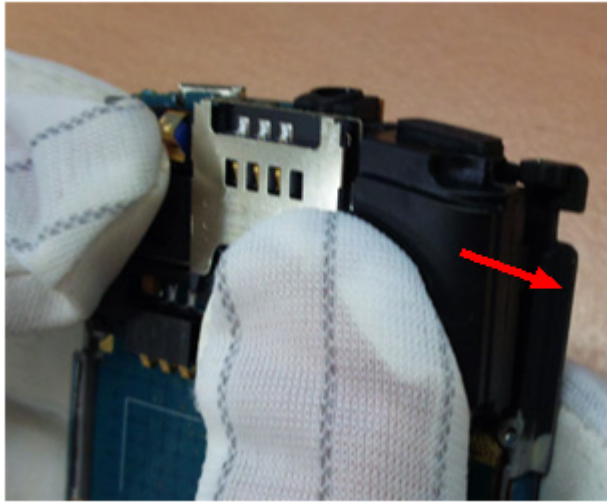

Speaker module lands, pushing the left side first.

6

Assemble FPCB

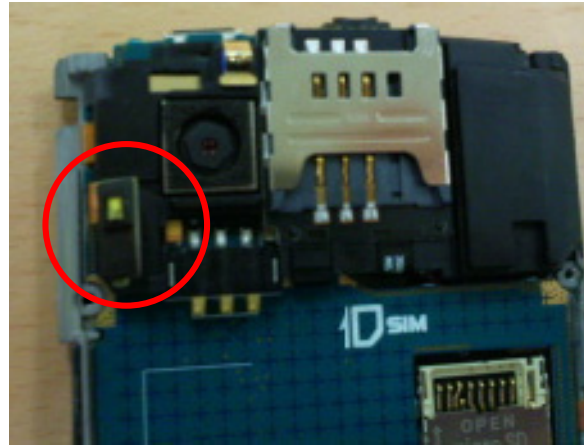

Attach FPCB to outline

7

Assemble REAR

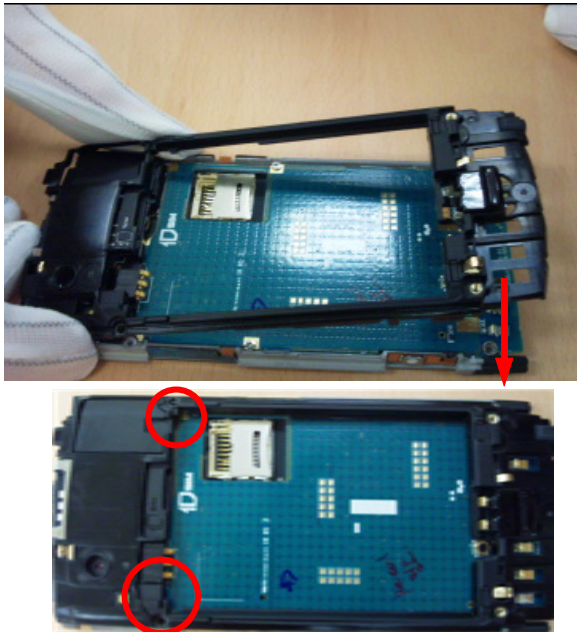

Land REAR on PBA and screw REAR 2-point

8

Assemble intenna

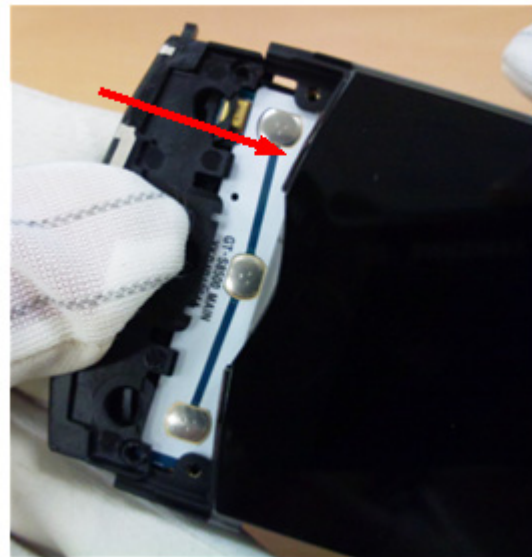

Insert intenna



9

Screw intenna



10

Assemble front key pad



Screw intenna 2-point

Land the front key pad

11

Assemble intenna cover



12

Screw intenna cover

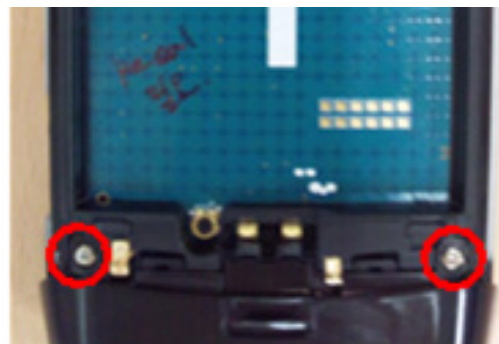

Insert intenna's cover

Screw intena cover 2-point

13

Slide Case body down



Slide Case body down

14

Assemble upper Deco

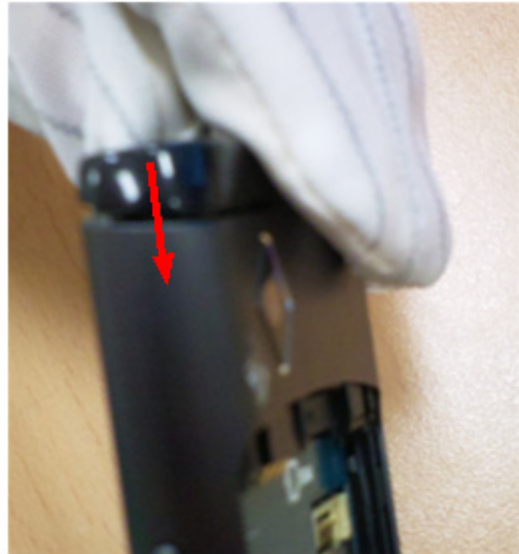

Insert upper Deco into Case body

15

Screw upper Deco



Screw upper Deco 3-point

16

Assemble upper Deco cover



attach upper Deco cover

## 7-2. Disassembly

1

Disassemble upper Deco cover



Detach upper Deco's cover with pincette

2

Unscrew upper Deco



Unscrew upper Deco 3-point

3

Disassemble upper Deco



Pull upper Deco after hold it

4

Disassemble Case body



Slide the Case body up

5

Unscrew REAR



Unscrew REAR 4-point

6

Disassemble intenna's cover



TO disassemble intenna's cover, widen the hook of the intenna's cover with disassembling knife

7

Disassemble intenna cover

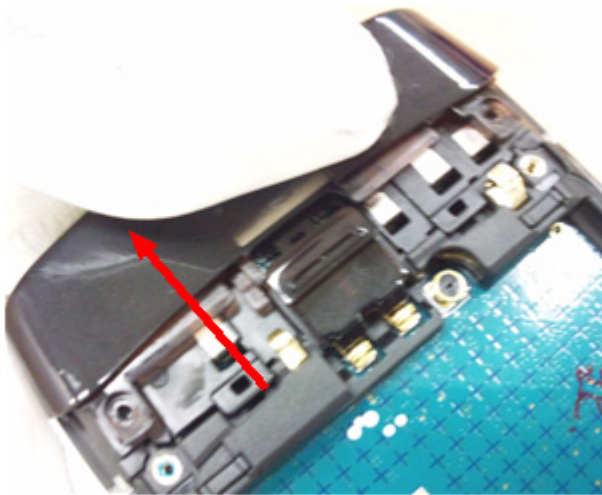

Pull intenna's cover after hold it

8

Disassemble front key pad



Hold up key pad



**9** Unscrew intenna



**10** Disassemble intenna

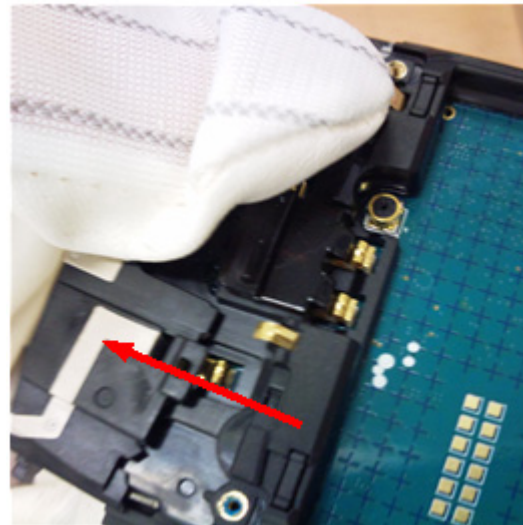

Unscrew intenna 2-point

Pull an intena after hold it

**11** Disassemble the REAR

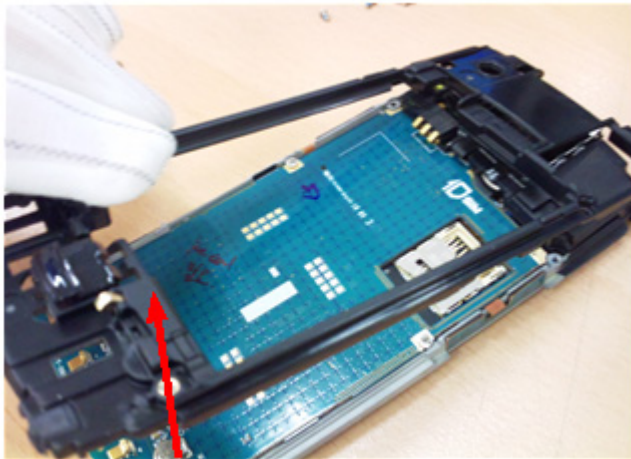

**12** Disassemble FPAB

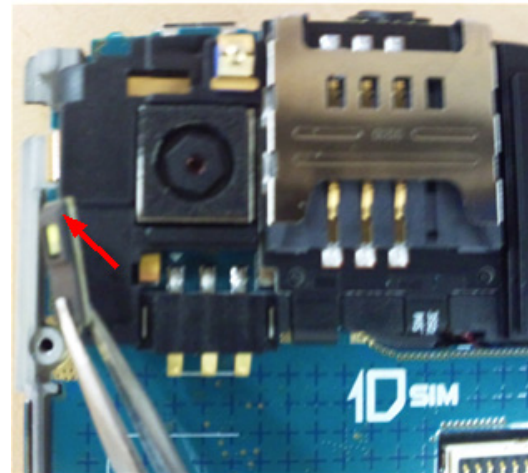

Hold the REAR up

Detach FPCB with tweezers

13

Disassemble Camera cover

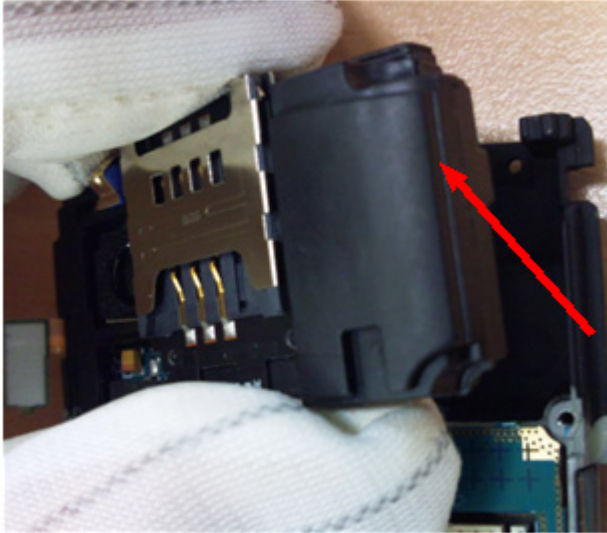

hold up the Camera cover right side

14

Disassemble FPAB

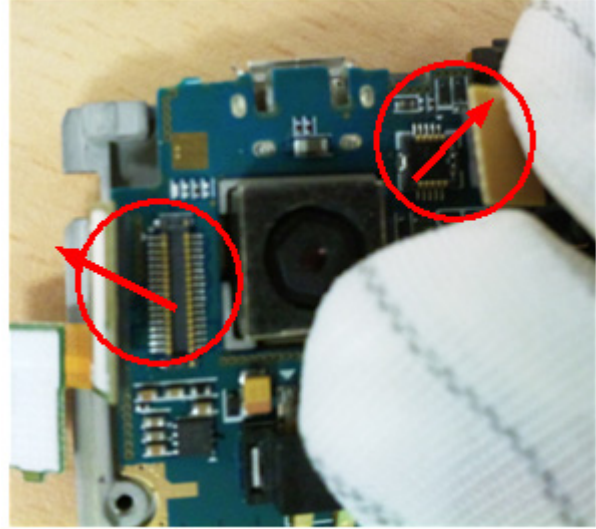

Disassemble FPCB 2-point

15

Unscrew PBA

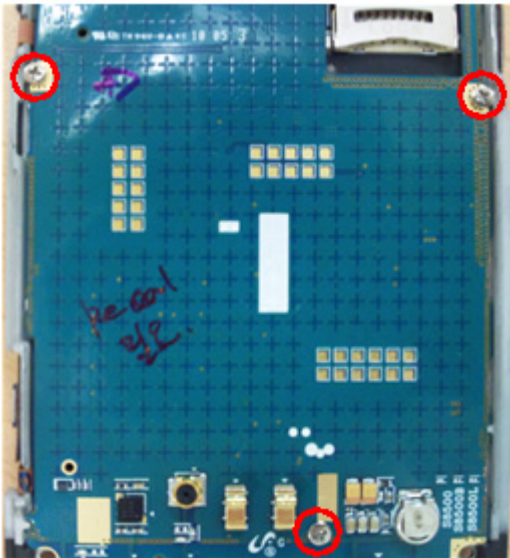

Unscrew PBA 3-point

16

Detach FPCB

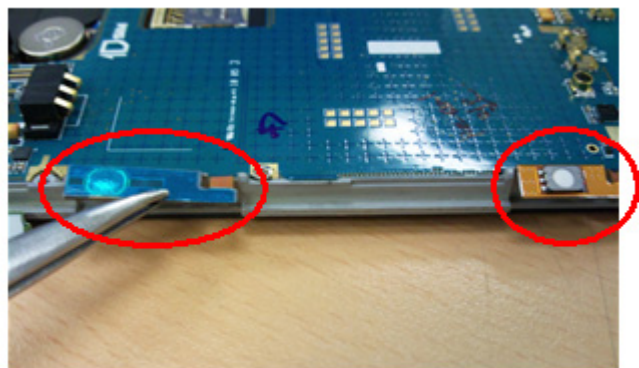

Detach FPCB 2-point with tweezers

17

Disassemble PBA

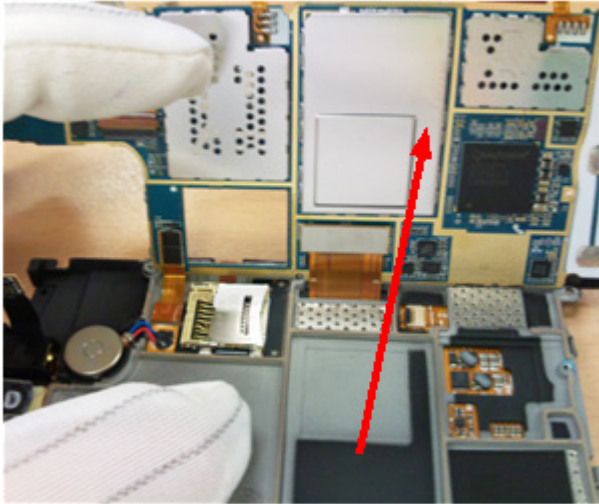

Hold up PBA

18

Disassemble PBA

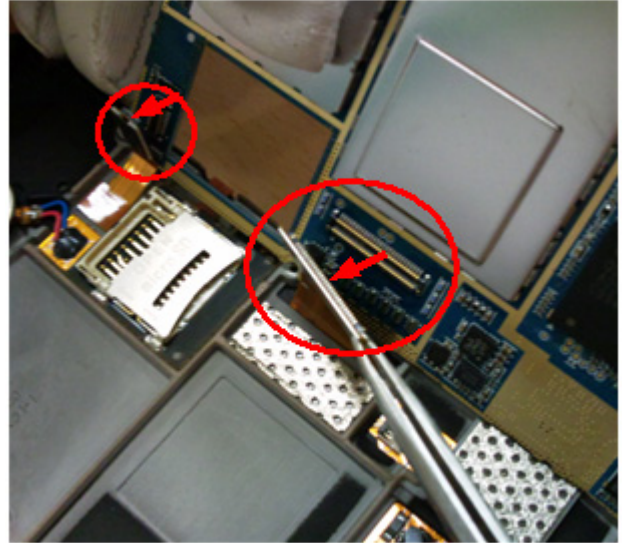

Detach FPCB 2-point with tweezers

## 5. MAIN Electrical Parts List

Design LOC	SEC CODE	Description
ZD402	0403-001688	DIODE-ZENER
D400, D401, ZD300	0406-001223	DIODE-TVS
ZD400	0406-001237	DIODE-TVS
V200, V201, ZD200, ZD201, ZD202, ZD203, ZD204, ZD205, ZD206	0406-001267	DIODE-TVS
ZD601	0406-001322	DIODE-TVS
ZD401	0406-001375	DIODE-TVS
D600	0407-001002	DIODE-ARRAY
Q300	0504-000168	TR-DIGITAL
Q400	0504-001138	TR-DIGITAL
U105	0801-003013	IC-CMOS LOGIC
UCP500	0902-002559	IC-MICROPROCESSOR
U204	1001-001461	IC-ANALOG SWITCH
U200	1001-001488	IC-ANALOG SWITCH
U401	1001-001580	IC-ANALOG MULTIPLEX
U607	1003-002047	IC-MOTOR DRIVER
U201	1003-002102	IC-LEVEL DRIVER
U303	1003-002352	IC-LEVEL DRIVER
UME200	1107-001942	IC-FLASH MEMORY
U100	1201-002961	IC-POWER AMP
U101	1201-003009	IC-POWER AMP
U206	1202-001036	IC-VOLTAGE COMP.
U400	1203-004339	IC-MULTI REG.
U203	1203-004524	IC-MULTI REG.
U606	1203-004571	IC-MULTI REG.
U408	1203-004819	IC-POSI.FIXED REG.
U407	1203-005503	IC-DC/DC CONVERTER
U605	1203-005772	IC-VOL. DETECTOR
U602	1203-006186	IC-POWER SUPERVISOR
U601	1203-006372	IC-RESET
U102	1204-003026	IC-TUNER
U104	1205-003791	IC-RECEIVER
U205	1205-003943	IC-CODEC
U302	1205-003961	IC-MODEM
U604	1209-001817	IC-SENSOR
U609	1209-001872	IC-SENSOR



Design LOC	SEC CODE	Description
U301	1404-001165	THERMISTOR-NTC
U402, U403, U406, V405, V406, V407, V411	1405-001183	VARISTOR
V402, V403, V404, V408, V409	1405-001231	VARISTOR
R212	2007-000138	R-CHIP
R310	2007-000144	R-CHIP
R605, R610	2007-000148	R-CHIP
R425	2007-000152	R-CHIP
R609	2007-000162	R-CHIP
R309	2007-000932	R-CHIP
R228	2007-001119	R-CHIP
R521	2007-001319	R-CHIP
R424	2007-003006	R-CHIP
R570	2007-007009	R-CHIP
R323	2007-007156	R-CHIP
R611	2007-007334	R-CHIP
R209	2007-007573	R-CHIP
R114	2007-007741	R-CHIP
R431	2007-007875	R-CHIP
R411	2007-007943	R-CHIP
R103, R204, R207	2007-008044	R-CHIP
R102, R104, R200, R202, R203, R205, R304, R311, R312, R328, R526, R527, R532, R604	2007-008045	R-CHIP
R303	2007-008049	R-CHIP
R234, R504, R602	2007-008052	R-CHIP
R121, R223, R428, R429, R539, R540, R542, R543, R559	2007-008055	R-CHIP
R606, R607	2007-008057	R-CHIP
C101, C108	2007-008210	R-CHIP
R226, R227	2007-008211	R-CHIP
R105, R307, R308, R515, R516, R517, R518, R519, R520, R550, R551, R552, R553, R554, R555, R562, R563, R572, R573	2007-008419	R-CHIP
R229	2007-008478	R-CHIP
R315, R416, R417, R419, R420, R421	2007-008483	R-CHIP
R608	2007-008502	R-CHIP
R116, R117, R118, R119, R120, R230, R232, R233, R300, R409, R430, R523, R524, R525, R529, R533, R535, R536, R537, R571	2007-008516	R-CHIP

Design LOC	SEC CODE	Description
R107, R211, R213, R415	2007-008531	R-CHIP
R433	2007-008564	R-CHIP
C102, C103, C109, C110	2007-008582	R-CHIP
R432	2007-008588	R-CHIP
R321	2007-008766	R-CHIP
R108, R426, R427	2007-008774	R-CHIP
R111, R115, R423, R574, R575	2007-008806	R-CHIP
R201, R206	2007-009084	R-CHIP
R218, R219, R220, R221, R222	2007-009171	R-CHIP
R601, R603	2007-009314	R-CHIP
R100	2007-009408	R-CHIP
R113	2007-009801	R-CHIP
R556, R557	2007-009964	R-CHIP
R514	2007-010029	R-CHIP
C600	2203-000233	C-CER,CHIP
C241, C616, C638	2203-000386	C-CER,CHIP
C652	2203-000425	C-CER,CHIP
C647	2203-000725	C-CER,CHIP
C240	2203-001072	C-CER,CHIP
C119	2203-002677	C-CER,CHIP
C651	2203-002709	C-CER,CHIP
C526	2203-005138	C-CER,CHIP
C438	2203-005383	C-CER,CHIP
C107, C115, C133, C150, C152, C182, C184, C186, C198, C246, C364, C427, C429, C431	2203-005682	C-CER,CHIP
C117, C118, C136, C137, C138, C139	2203-005719	C-CER,CHIP
C187	2203-005725	C-CER,CHIP
C153	2203-005729	C-CER,CHIP
C131, C206, C207	2203-005731	C-CER,CHIP
C200	2203-005732	C-CER,CHIP
C100, C159, C173, C183, C194, C196, C315, C317, C318, C329	2203-005736	C-CER,CHIP
C147	2203-005777	C-CER,CHIP
C125, C167, C195	2203-005789	C-CER,CHIP
C143, C300, C527, C528	2203-005806	C-CER,CHIP
C160, C307, C308, C503	2203-006048	C-CER,CHIP
C185	2203-006120	C-CER,CHIP

Design LOC	SEC CODE	Description
C154	2203-006123	C-CER,CHIP
C521, C522	2203-006133	C-CER,CHIP
C640	2203-006137	C-CER,CHIP
C176, C181, C303, C314	2203-006194	C-CER,CHIP
C178, C179, C618, C619, C620	2203-006208	C-CER,CHIP
C645	2203-006257	C-CER,CHIP
C227	2203-006260	C-CER,CHIP
C441, C601	2203-006348	C-CER,CHIP
C216, C218, C219, C220, C222, C223, C225, C226, C228, C229, C332, C333, C409, C410, C411, C412, C418, C500, C502, C508, C602, C621, C622, C625, C627, C629, C631, C632, C635, C646, C649	2203-006399	C-CER,CHIP
C120, C170, C171, C201, C202, C210, C214, C221, C238, C239, C304, C305, C309, C311, C313, C330, C331, C346, C347, C352, C363, C406, C505, C509, C511, C514, C515, C518, C520, C523, C641	2203-006423	C-CER,CHIP
C302	2203-006462	C-CER,CHIP
C433	2203-006466	C-CER,CHIP
C249	2203-006556	C-CER,CHIP
C174, C215, C614, C615, C653	2203-006562	C-CER,CHIP
L113	2203-006611	C-CER,CHIP
C162, C501, C513	2203-006642	C-CER,CHIP
C116, C171	2203-006648	C-CER,CHIP
C148, C149, C158	2203-006674	C-CER,CHIP
C342	2203-006693	C-CER,CHIP
C164, C175, C603	2203-006824	C-CER,CHIP
C617, C654	2203-006825	C-CER,CHIP
C237, C404, C407, C510, C512, C623, C624, C626, C628, C630, C633, C634, C636, C650	2203-006838	C-CER,CHIP
C168, C169, C323, C325, C344, C345, C435, C524, C613, C637	2203-006839	C-CER,CHIP
C236, C242, C310, C642, C643	2203-006841	C-CER,CHIP
C306	2203-006846	C-CER,CHIP
C230, C231, C233, C334, C335, C336, C337, C338, C339, C340, C341, C343, C419, C425, C439, C440	2203-006872	C-CER,CHIP

Design LOC	SEC CODE	Description
C180	2203-006896	C-CER,CHIP
C644	2203-006979	C-CER,CHIP
C324	2203-006994	C-CER,CHIP
C360	2203-007147	C-CER,CHIP
C166	2203-007170	C-CER,CHIP
C104	2203-007194	C-CER,CHIP
C353, C354, C432	2203-007210	C-CER,CHIP
C105, C106, C161, C177, C320, C321, C348, C349, C361, C362	2203-007270	C-CER,CHIP
C224, C434, C436, C517	2203-007271	C-CER,CHIP
C211, C212, C213, C217, C234, C235, C312, C316, C319, C322, C327, C328, C350, C422, C426, C504, C506, C507, C516, C648	2203-007317	C-CER,CHIP
C172, C193, C355, C356, C357, C367, C368	2203-007369	C-CER,CHIP
C413	2203-007393	C-CER,CHIP
TA600, TA601, TA602, TA603, TA604, TA605, TA606	2404-001339	C-TA,CHIP
TA609	2404-001506	C-TA,CHIP
C369, C370, C437	2404-001516	C-TA,CHIP
TA200	2404-001596	C-TA,CHIP
L204	2703-000295	INDUCTOR-SMD
L101	2703-001178	INDUCTOR-SMD
L106	2703-001750	INDUCTOR-SMD
L604, L605	2703-002309	INDUCTOR-SMD
L117, L118	2703-002597	INDUCTOR-SMD
L100	2703-002710	INDUCTOR-SMD
L110	2703-002793	INDUCTOR-SMD
L109	2703-002794	INDUCTOR-SMD
L121	2703-002798	INDUCTOR-SMD
L122	2703-002858	INDUCTOR-SMD
L119, L303, L304	2703-002900	INDUCTOR-SMD
L111, L306	2703-002901	INDUCTOR-SMD
L104, L105	2703-002903	INDUCTOR-SMD
L108, L305	2703-002910	INDUCTOR-SMD
C141, C151, L114	2703-002917	INDUCTOR-SMD
C163	2703-002918	INDUCTOR-SMD
L102, L120	2703-002955	INDUCTOR-SMD



Design LOC	SEC CODE	Description
C127, C130	2703-003005	INDUCTOR-SMD
L600, L601, L602	2703-003343	INDUCTOR-SMD
L403	2703-003347	INDUCTOR-SMD
L300, L301, L302	2703-003685	INDUCTOR-SMD
L603	2703-003686	INDUCTOR-SMD
L116	2703-003698	INDUCTOR-SMD
OSC600	2801-004339	CRYSTAL-SMD
OSC500	2801-004458	CRYSTAL-SMD
U304	2801-004902	CRYSTAL-SMD
OSC100	2804-001884	OSCILLATOR-CLOCK
U300	2809-001324	OSCILLATOR-VCTCXO
F400, F401, F402, F403, F404, F405	2901-001413	FILTER-EMI SMD
F406, F407, F408	2901-001470	FILTER-EMI SMD
F104	2904-001779	FILTER-SAW
F102	2904-001785	FILTER-SAW
F103	2904-001789	FILTER-SAW
F101	2910-000065	DUPLEXER-SAW
F100	2911-000147	DUPLEXER-FEM
MIC200	3003-001138	MIC MEMS
L400	3301-001729	BEAD-SMD
L205	3301-001756	BEAD-SMD
L307	3301-001879	BEAD-SMD
L200, L201, L202, L203	3301-001885	BEAD-SMD
L206, L207	3301-001917	BEAD-SMD
L123	3301-001970	BEAD-SMD
CN100	3705-001503	CONNECTOR-COAXIAL
HDC401	3708-002162	CONNECTOR-FPC/FFC/PIC
HDC200	3711-005550	HEADER-BOARD TO BOARD
HDC400	3711-006483	HEADER-BOARD TO BOARD
HDC403	3711-006865	HEADER-BOARD TO BOARD
HDC402, HDC404	3711-006923	HEADER-BOARD TO BOARD
BTC600	3711-007312	CONNECTOR-HEADER
IFC400	3722-002919	JACK-EAR PHONE
BAT600	4302-001180	BATTERY-LI(2ND)
U103	4709-001844	W-LAN MODULE
SC200, SC201, SC202, SC203, SC204, SC205, SC206, SC207, SC208	GH70-03349A	IPR SHIELD-CAN CLIP

---

<b>Design LOC</b>	<b>SEC CODE</b>	<b>Description</b>
CLIP100, CLIP101	GH70-03928A	ICT-ANTENNA COTACT
SC101	GH70-06167A	ICT BRACKET-SHIELD FRAME 1
SC100	GH70-06168A	ICT BRACKET-SHIELD FRAME 2
ANT100, ANT101, ANT102, ANT104	GH71-08426A	NPR CONTACT-ANTENNA

Please consult the GSPN website (Samsung Portal) for the most recent version of the product's part list.

## 4. Exploded View and Parts List

### 4-1. Cellular phone Exploded View

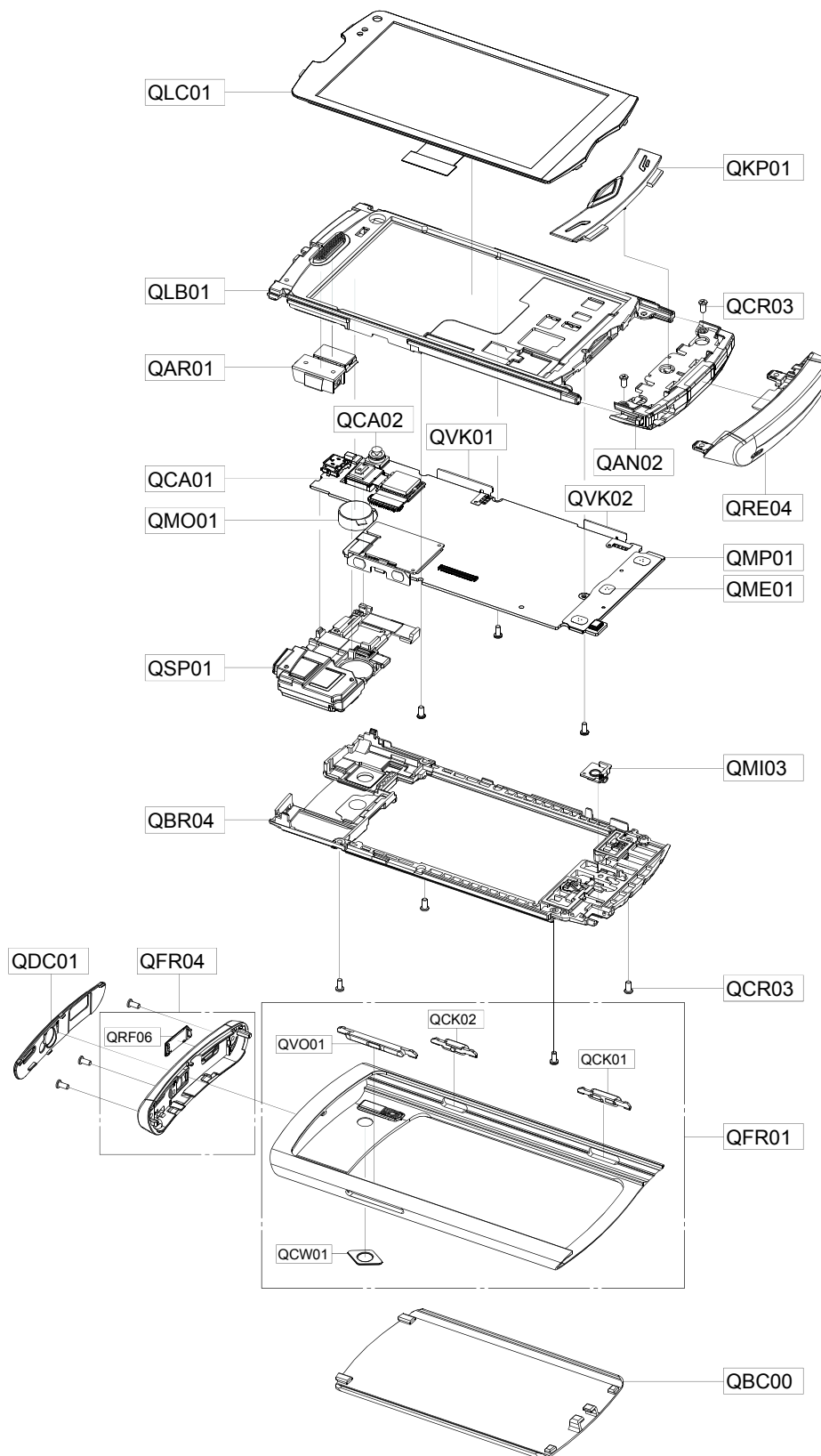

- This Document can not be used without Samsung's authorization -

## 5-2. Cellular phone Parts list : GT-S8500BAASFR

Design LOC	Description	SEC CODE
QAN02	INTENNA-MAIN (GT-S8500)	GH42-02382A
QAR01	MODULE-RCV/EAR-JACK(GT-S8500)	GH59-09052A
QBC00	NPR COVER-BATT	GH71-09357A
QBR04	ASSY BRACKET-REAR	GH98-16762A
QCA01	ASSY CAMERA-MODULE,GT-S8500(5M)	GH96-04749A
QCA02	ASSY CAMERA-VGA MODULE(GT-S8500)	GH96-04323A
QCK01	PMO KEY-CAMERA	GH72-58321A
QCK02	PMO KEY-HOLD	GH72-58457A
QCR03	SCREW-MACHINE	6001-001811
QCW01	ASSY DECO-WINDOW CAMERA	GH98-16912A
QDC01	ASSY DECO-TOP	GH98-16731A
QFR01	ASSY CASE-BODY	GH98-16764A
QFR04	ASSY DECO-FRONT	GH98-16729A
QKP01	ASSY KEYPAD-(EU/GRAY)	GH98-16763A
QLC01	MEA-BRACKET GT_S8500	GH97-11216A
QME01	DOME SHEET-SUB 3 KEY(GT-S8500)	GH59-08956A
QMI03	ASSY RUBBER-MIC	GH98-16944A
QMO01	ASSY ETC-T-FLASH FPCB+MOT+V/K ASSY(GT-S8	GH59-08932A
QMP01	A/S ASSY-PBA MAIN,GT-8500,XEF(SVC)	GH82-04739A
QRE04	ASSY DECO-REAR(SFR)	GH98-17294A
QRF06	PMO COVER-USB	GH72-58338A
QSP01	MODULE-SPEAKER+SIM SOCKET (GT-S8500)	GH59-09040A
QVK01	KEY FPCB-HOLD KEY(GT-S8500)	GH59-09143A
QVK02	KEY FPCB-CAMERA KEY(GT-S8500)	GH59-08955A
QVO01	PMO KEY-VOLUME	GH72-58336A



## 2. Specification

### 2-1. GSM General Specification

	<b>GSM850 Phase 1</b>	<b>EGSM 900 Phase 2</b>	<b>DCS1800 Phase 1</b>	<b>PCS1900</b>	<b>WCDMA2100</b>	<b>WCDMA900</b>
Freq. Band[MHz] Uplink/Downlink	824~849 869~894	880~915 925~960	1710~1785 1805~1880	1850~1910 1930~1990	1922~1977 2112~2167	880~915 925~960
ARFCN range	128~251	0~124 & 975~1023	512~885	512~810	UL:9612~9888 DL:10562~10838	UL:2712~2863 DL:2937~3088
Tx/Rx spacing	45MHz	45MHz	95MHz	80MHz	190MHz	45MHz
Mod. Bit rate/ Bit Period	270.833kbps 3.692us	270.833kbps 3.692us	270.833kbps 3.692us	270.833kbps 3.692us	3.84Mcps	3.84Mcps
Time Slot Period/Frame Period	576.9us 4.615ms	576.9us 4.615ms	576.9us 4.615ms	576.9us 4.615ms	FrameLength: 10ms Slotlength: 0.667ms	FrameLength: 10ms Slotlength: 0.667ms
Modulation	0.3GMSK	0.3GMSK	0.3GMSK	0.3GMSK	QPSKHQPSK	QPSKHQPSK
MS Power	33dBm~5dBm	33dBm~5dBm	30dBm~0dBm	30dBm~0dBm	24dBm~-50dBm	24dBm~-50dBm
Power Class	5pcl ~ 19pcl	5pcl ~ 19pcl	0pcl ~ 15pcl	0pcl ~ 15pcl	3(max+24dBm)	3(max+24dBm)
Sensitivity	-102dBm	-102dBm	-100dBm	-100dBm	-106.7dBm	-106.7dBm
TDMA Mux	8	8	8	8	8	8
Cell Radius	35Km	35Km	2Km	2Km	2Km	2Km

## 2-2. GSM Tx Power Class

<b>TX Power control level</b>	<b>GSM850</b>	<b>TX Power control level</b>	<b>EGSM900</b>	<b>TX Power control level</b>	<b>DCS1800</b>	<b>TX Power control level</b>	<b>PCS1900</b>
5	33±2 dBm	5	33±2 dBm	0	30±3 dBm	0	30±3 dBm
6	31±2 dBm	6	31±2 dBm	1	28±3 dBm	1	28±3 dBm
7	29±2 dBm	7	29±2 dBm	2	26±3 dBm	2	26±3 dBm
8	27±2 dBm	8	27±2 dBm	3	24±3 dBm	3	24±3 dBm
9	25±2 dBm	9	25±2 dBm	4	22±3 dBm	4	22±3 dBm
10	23±2 dBm	10	23±2 dBm	5	20±3 dBm	5	20±3 dBm
11	21±2 dBm	11	21±2 dBm	6	18±3 dBm	6	18±3 dBm
12	19±2 dBm	12	19±2 dBm	7	16±3 dBm	7	16±3 dBm
13	17±2 dBm	13	17±2 dBm	8	14±3 dBm	8	14±3 dBm
14	15±2 dBm	14	15±2 dBm	9	12±4 dBm	9	12±4 dBm
15	13±2 dBm	15	13±2 dBm	10	10±4 dBm	10	10±4 dBm
16	11±3 dBm	16	11±3 dBm	11	8±4 dBm	11	8±4 dBm
17	9±3dBm	17	9±3dBm	12	6±4 dBm	12	6±4 dBm
18	7±3 dBm	18	7±3 dBm	13	4±4 dBm	13	4±4 dBm
19	5±3 dBm	19	5±3 dBm	14	2±5 dBm	14	2±5 dBm
				15	0±5 dBm	15	0±5 dBm

---

## 3. Operation Instruction and Installation

---

### Main Function

- GSM(2G EDGE/GPRS) 850/900/1800/1900
- WCDMA(3G HSDPA) 900/2100
- 3.3" WVGA 16M OCTA (On Cell TSP AMOLED)
- 1GHz Application Processor
- Seamless Onebody
- 5M pixel AF Camera with Power LED Flash
- HD video Playing(Divx, Xvid)/Recording
- FM Radio with RDS and real time recording
- Bluetooth v3.0
- USB 2.0 FS / Wi-Fi 802.11n / GPS
- Music player : MP3/AAC/AAC+/eAAC+/WMA/AMR/MIDI/SP-MIDI/i-melody/WAV/MMF
- Accelerator Sensor / Proximity Sensor / G-sensor
- Touch WIZ 3.0 UI , Application store
- Voice & Motion UI
- SMS/MMS/Email/Video Messaging E-mail/Push E-mail(Exchange ActiveSync)
- Multi-touch
- Multi-task manager
- TV-OUT
- Navigation
- Voice recording

---

## 6. Level 1 Repair

---

### 6-1. S/W Download

#### 6-1-1. Pre-requisite for S/W Downloading

- GT-S8500 Mobile Phone
  - RF Test Cable : GH39-00985A
  - Anyway JIG BOX : GH99-36900A
  - Anyway JIG BOX Adaptor : GH44-01860A
  - Test Cable : GH39-01290A
  - Adapter : GH99-38251A
  - Power supply (eg. Agilent E3632A or similar one)
  - Downloader Program([Downloader V5.62](#))
  - Binary files
  - PC (Windows XP)
- ※ **The settings for download.**

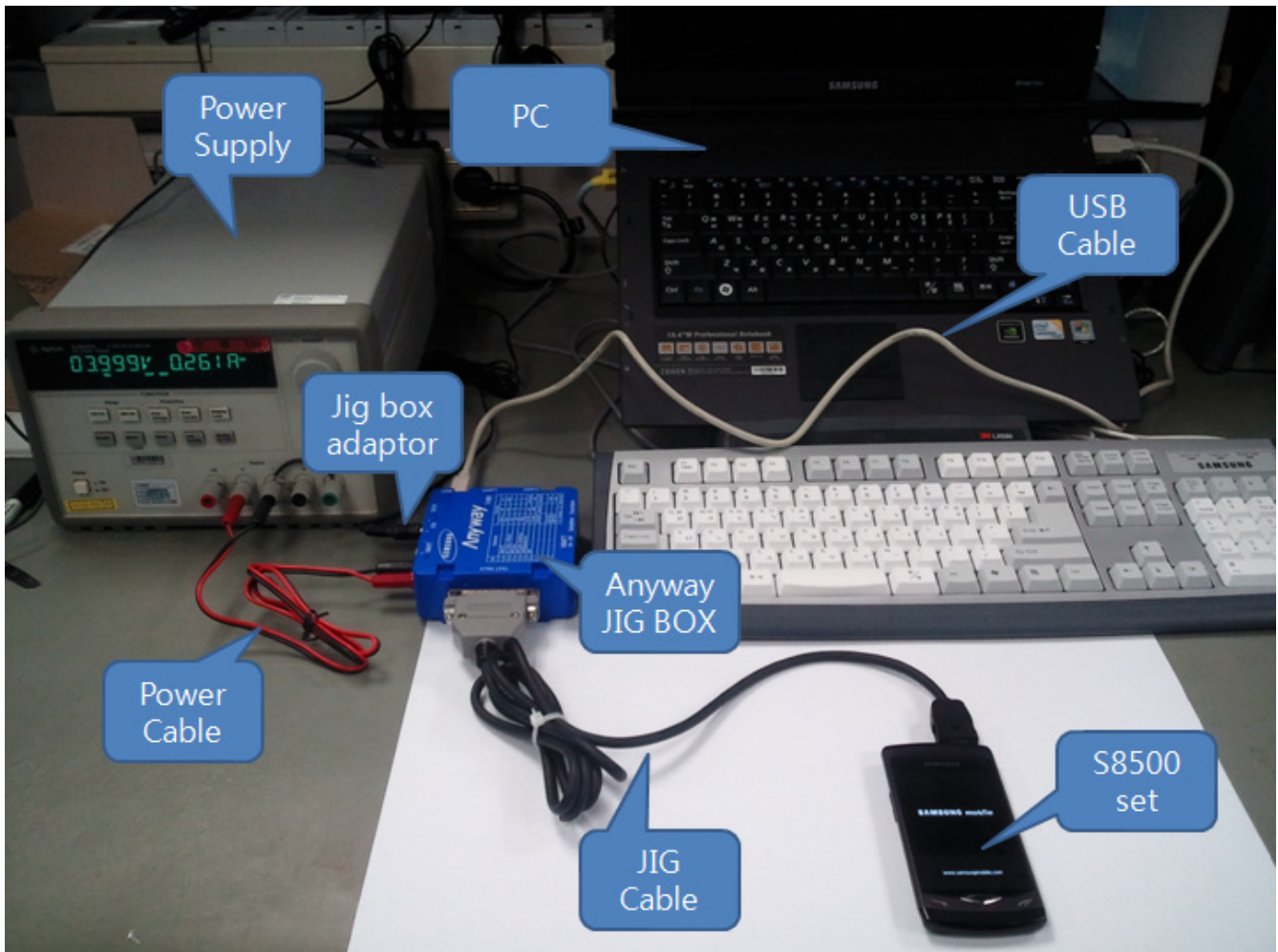



### 6-1-2. S/W Downloader Program

1. Load the binary download program by executing the [Downloader V5.62](#)
2. Select "LSI6410" and Check "Full Download"
3. Load the file of Boot, Amss, Apps, Rsrc 1. Rsrc2, Factory FS from the folder that you saved the binary files. (Drag & Drop form file folder)
4. Click the "Port Search" when the download cable is connected to PC

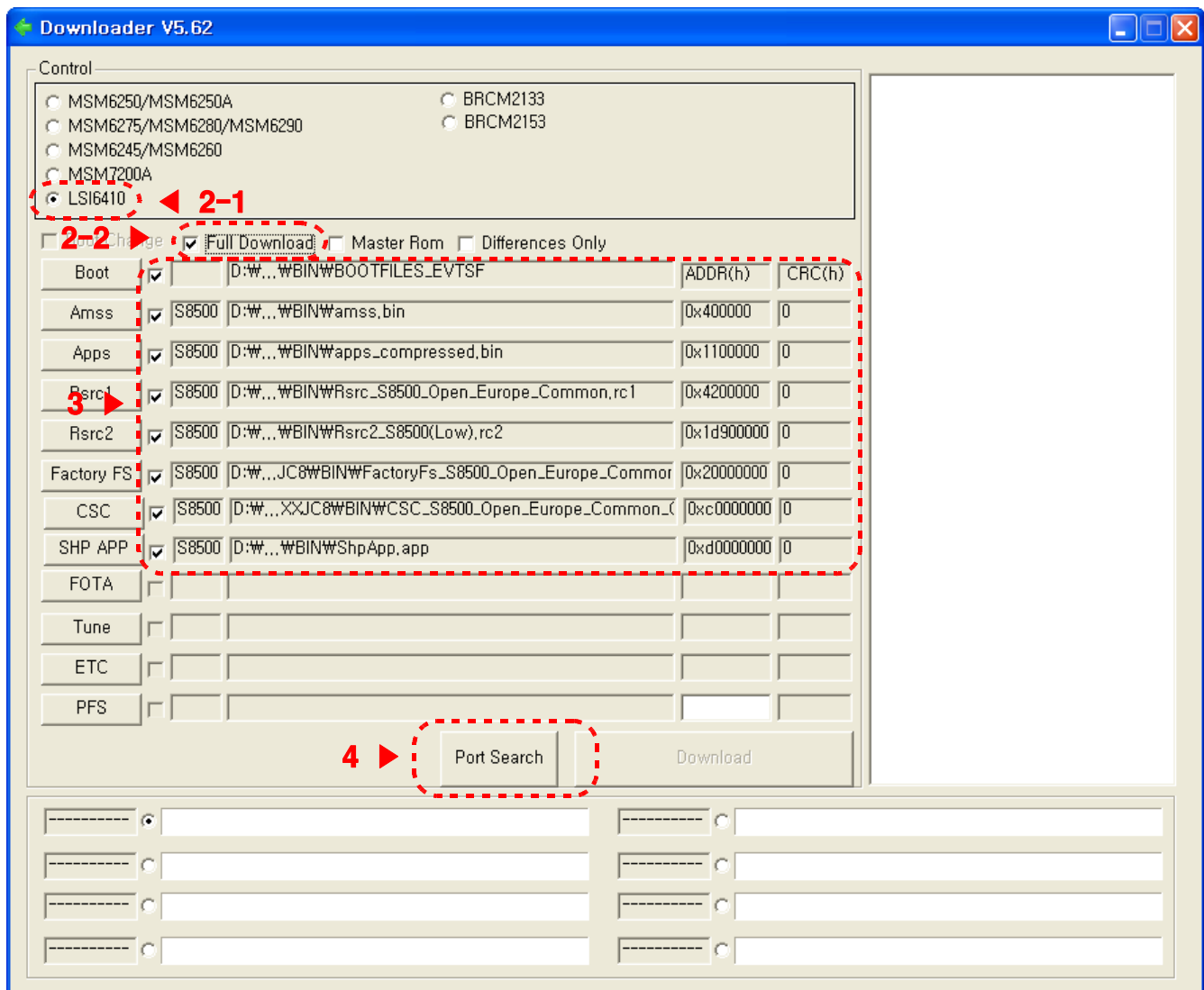

5. Click download when the port ready.

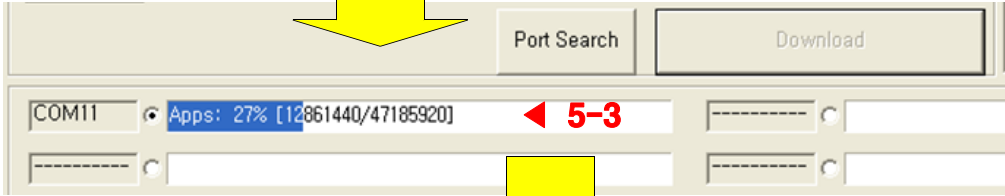
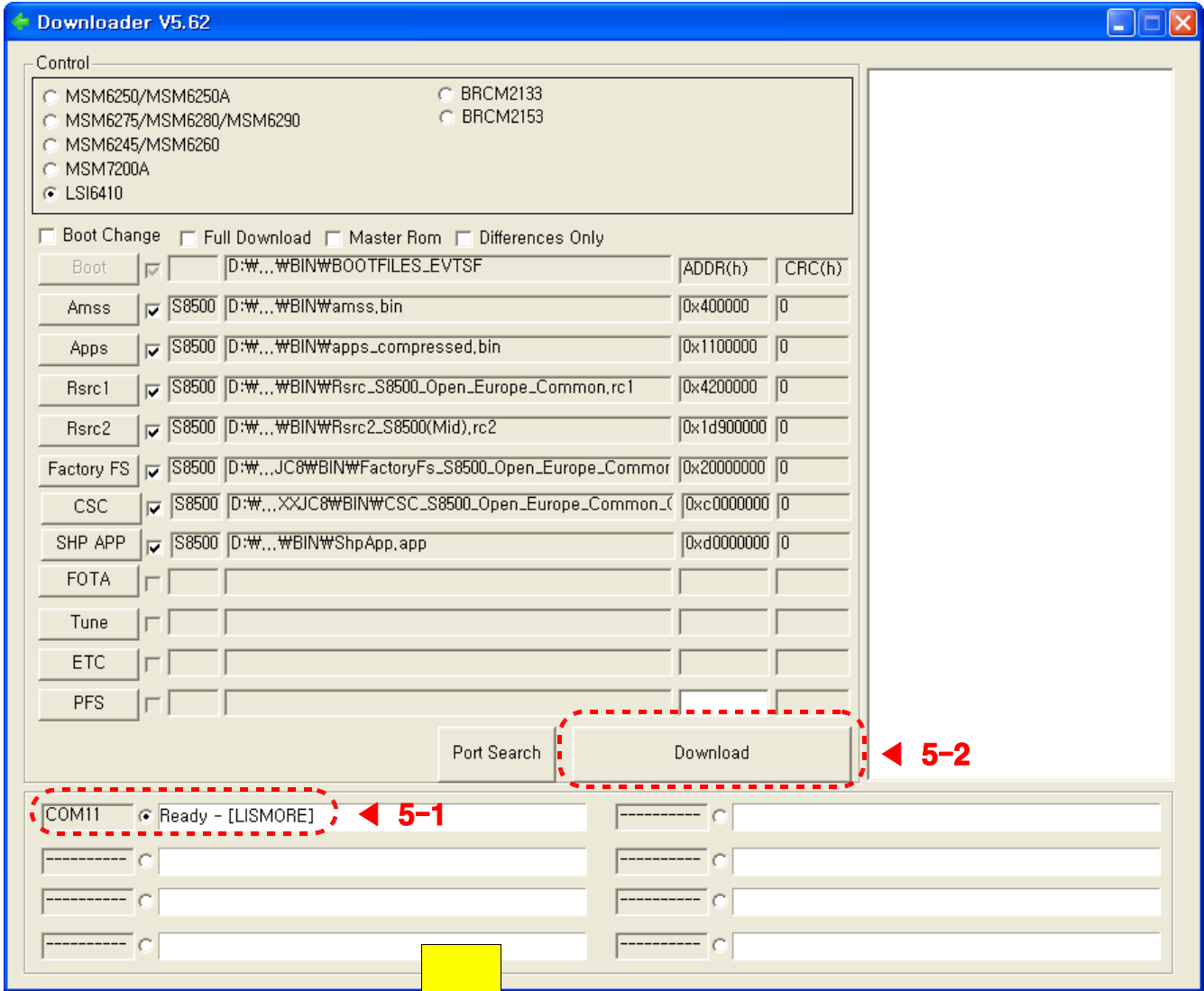

- 6. When downloading is finished successfully, there is a "All files complete" message
- 7. Wait until the mobile is completely booting. It takes few minute
- 8. Check the bin ver. (\*#197328640# → 2 → 1 → 2)

---

## 9. Reference Abbreviate

---

### Reference Abbreviate

- **AAC**: Advanced Audio Coding.
- **AVC** : Advanced Video Coding.
- **BER** : Bit Error Rate
- **BPSK**: Binary Phase Shift Keying
- **CA** : Conditional Access
- **CDM** : Code Division Multiplexing
- **C/I** : Carrier to Interference
- **DMB** : Digital Multimedia Broadcasting
- **EN** : European Standard
- **ES** : Elementary Stream
- **ETSI**: European Telecommunications Standards Institute
- **MPEG**: Moving Picture Experts Group
- **PN** : Pseudo-random Noise
- **PS** : Pilot Symbol
- **QPSK**: Quadrature Phase Shift Keying
- **RS** : Reed-Solomon
- **SI** : Service Information
- **TDM** : Time Division Multiplexing
- **TS** : Transport Stream

---

# 1. Safety Precautions

---

## 1-1. Repair Precaution

- Repair in Shield Box, during detailed tuning. Take specially care of tuning or test, because specipcty of cellular phone is sensitive for surrounding interference(RF noise).
- Be careful to use a kind of magnetic object or tool, because performance of parts is damaged by the influence of magnetic force.
- Surely use a standard screwdriver when you disassemble this product, otherwise screw will be worn away.
- Use a thicken twisted wire when you measure level.  
A thicken twisted wire has low resistance, therefore error of measurement is few.
- Repair after separate Test Pack and Set because for short danger (for example an overcurrent and furious flames of parts etc) when you repair board in condition of connecting Test Pack and tuning on.
- Take specially care of soldering, because Land of PCB is small and weak in heat.
- Surely tune on/off while using AC power plug, because a repair of battery charger is dangerous when tuning ON/OFF PBA and Connector after disassembling charger.
- Don't use as you pleases after change other material than replacement registered on SEC System. Otherwise engineer in charge isn't charged with problem that you don't keep this rules.

## 1-2. ESD(Electrostatically Sensitive Devices) Precaution

Several semiconductor may be damaged easily by static electricity. Such parts are called by ESD (Electrostatically Sensitive Devices), for example IC,BGA chip etc. Read Precaution below.

You can prevent from ESD damage by static electricity.

- Remove static electricity remained your body before you touch semiconductor or parts with semiconductor. There are ways that you touch an earthed place or wear static electricity prevention string on wrist.
- Use earthed soldering steel when you connect or disconnect ESD.
- Use soldering removing tool to break static electricity. , otherwise ESD will be damaged by static electricity.
- Don't unpack until you set up ESD on product. Because most of ESD are packed by box and aluminum plate to have conductive power,they are prevented from static electricity.
- You must maintain electric contact between ESD and place due to be set up until ESD is connected completely to the proper place or a circuit board.

# 8. Level 3 Repair

## 8-1. Block Diagram

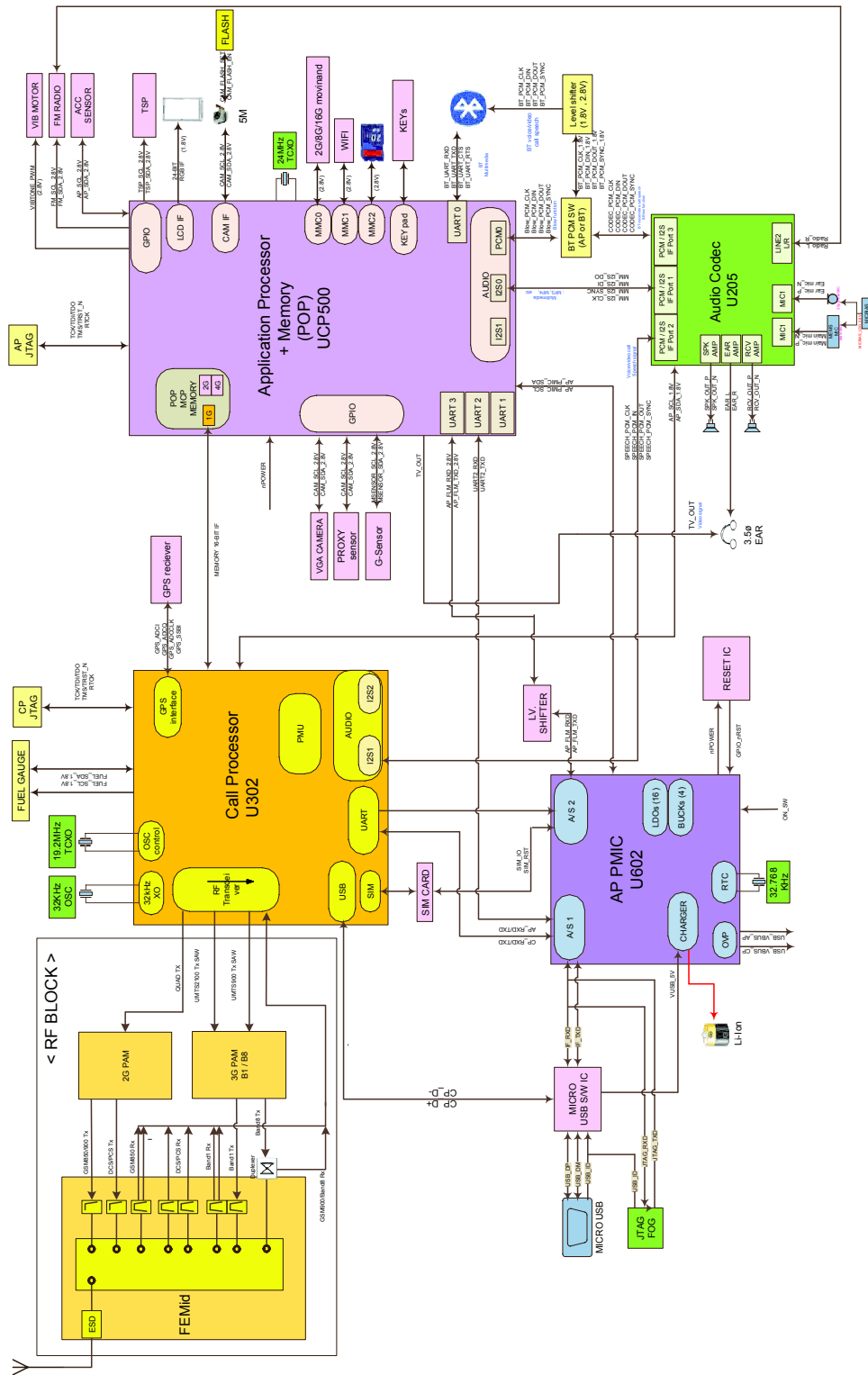



## 8-2. PCB Diagrams

### 8-2-1. Top

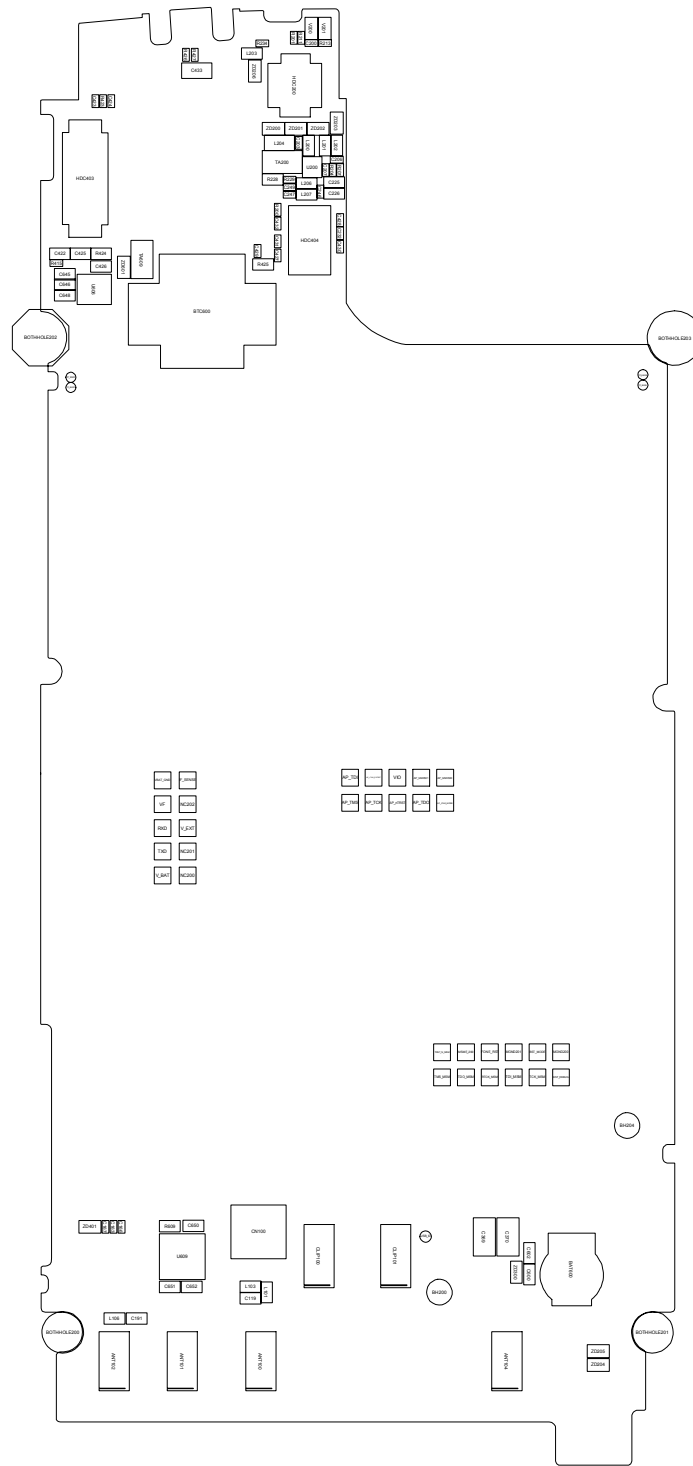

8-2-2. Bottom

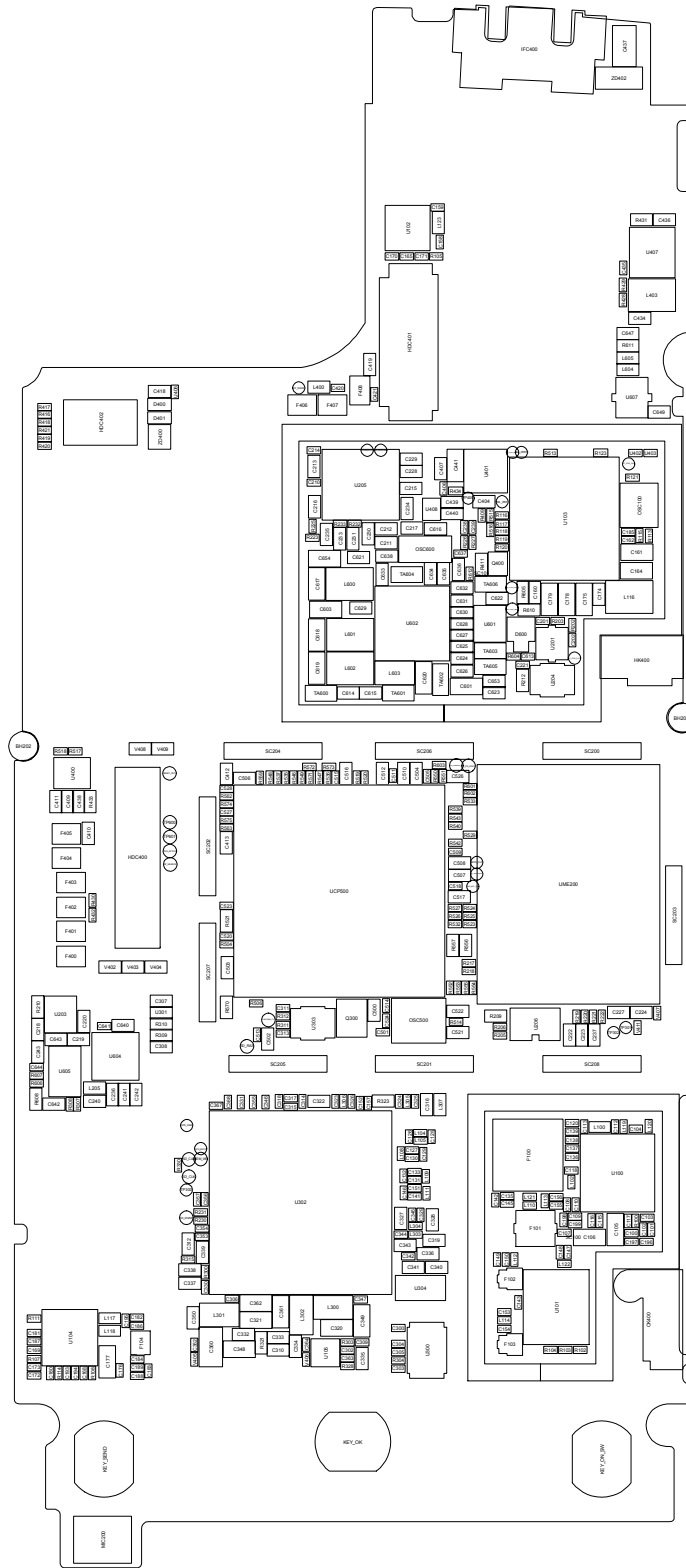

### 8-3. Flow Chart of Troubleshooting

#### Equipment

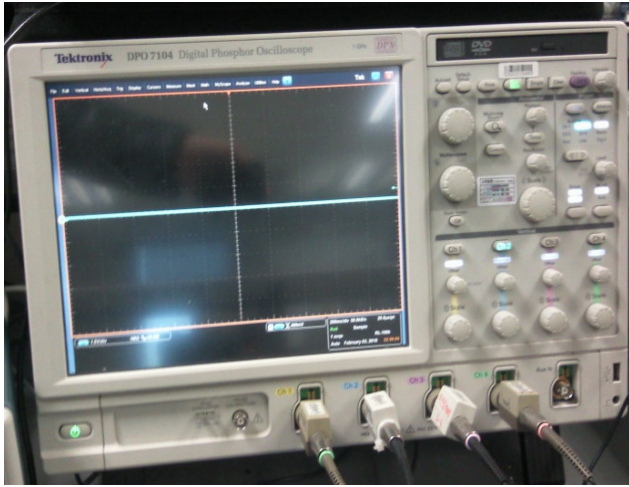

↑ Oscilloscope



↑ Digital Multimeter



↑ Power Supply



↑ + driver, Tweezer

8-3-1. Power On

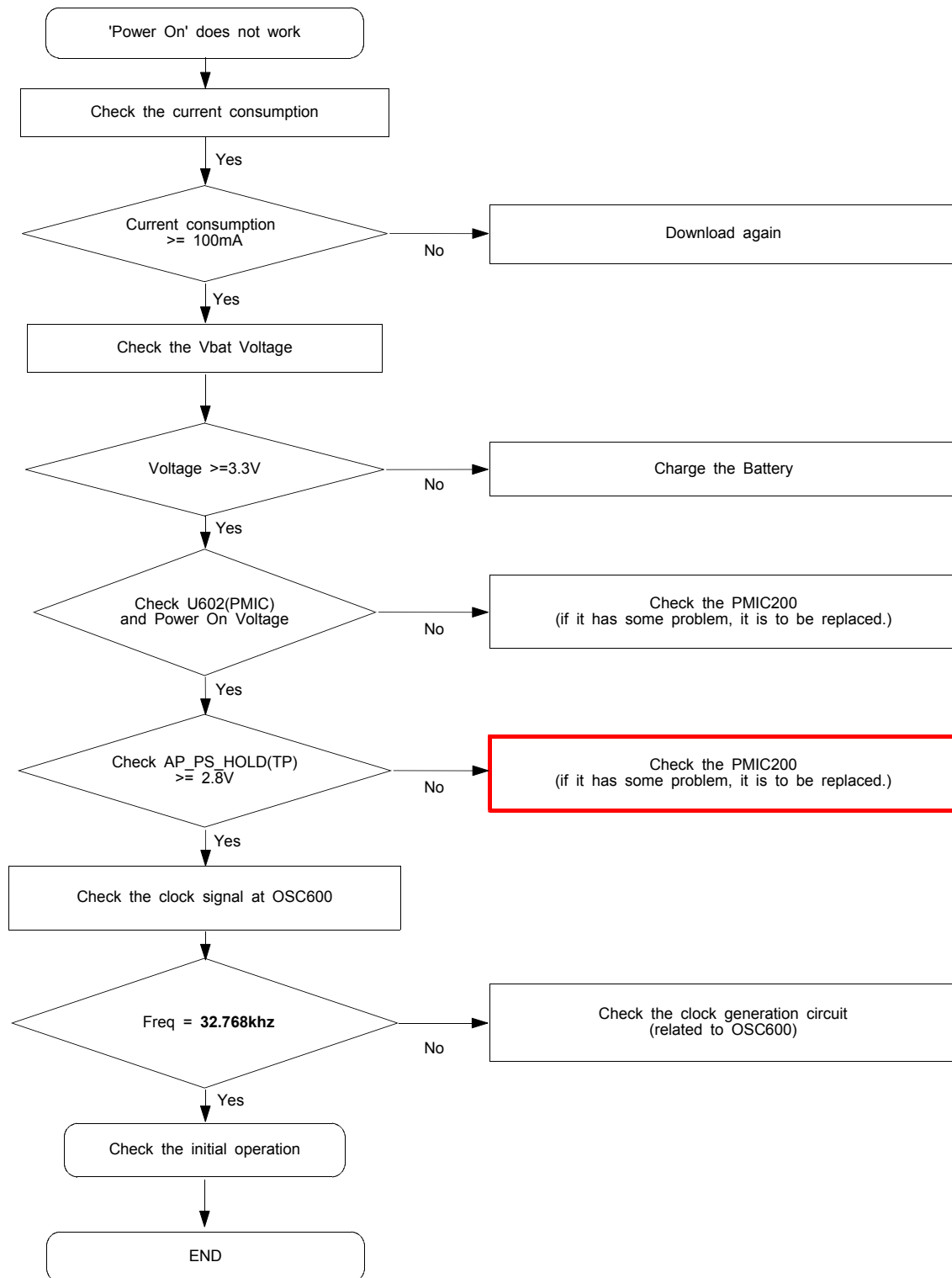



8-3-2. Initial

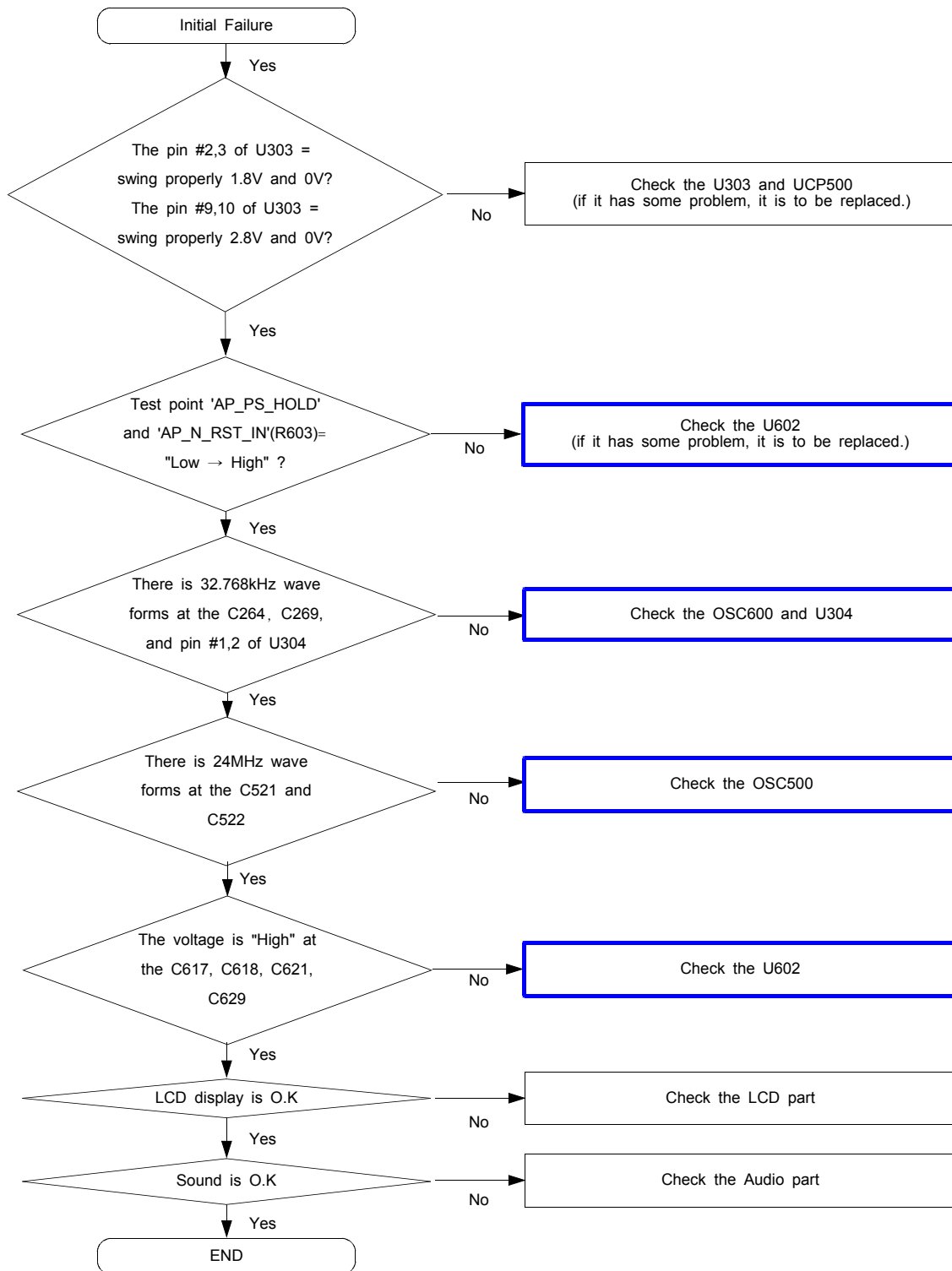





8-3-3. SIM

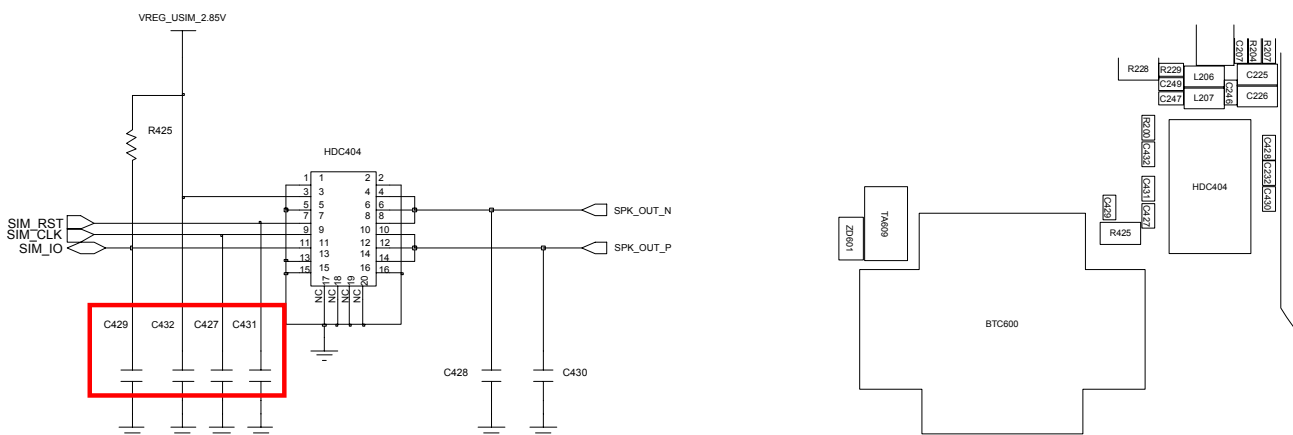
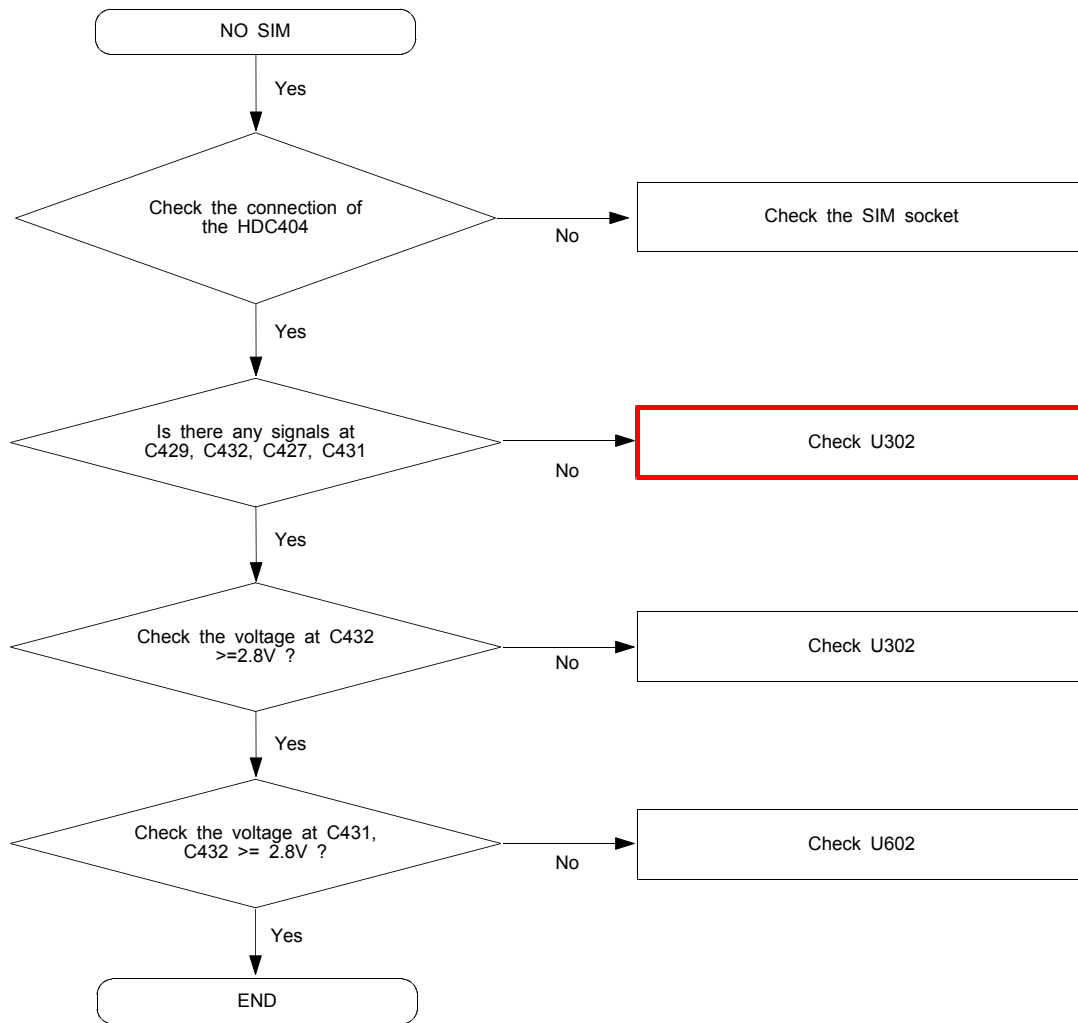

8-3-4. Microphone

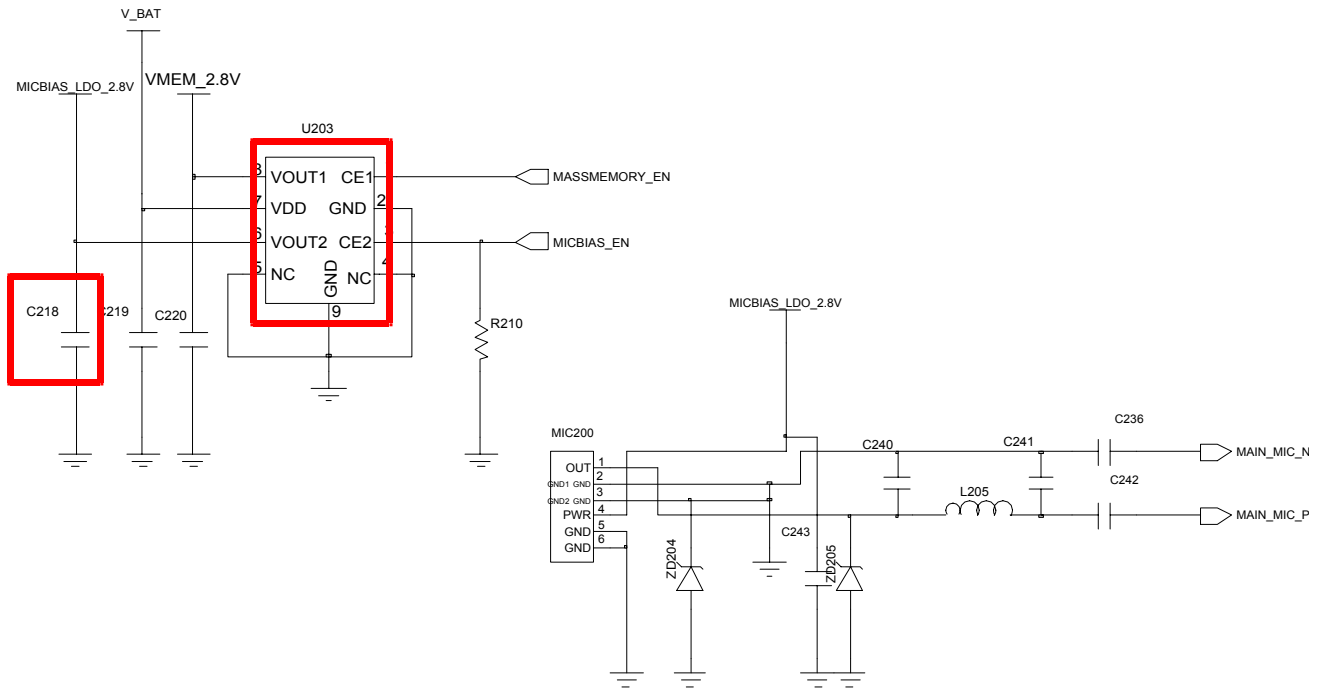
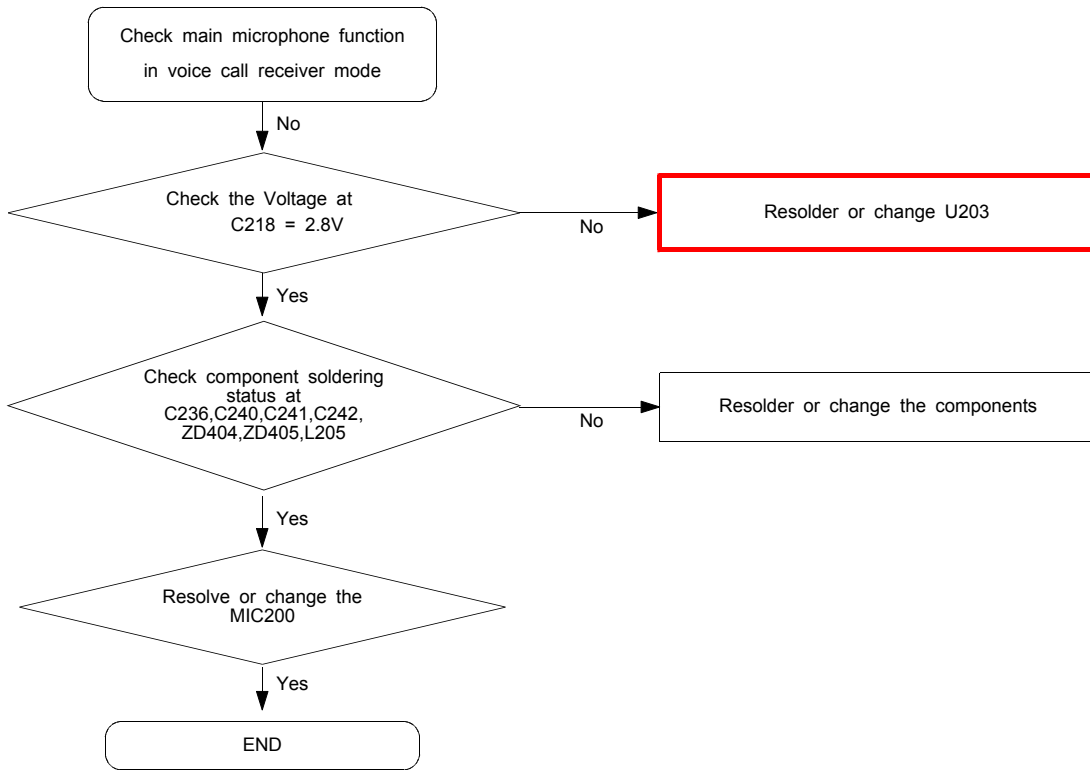

### 8-3-5. Ear Microphone

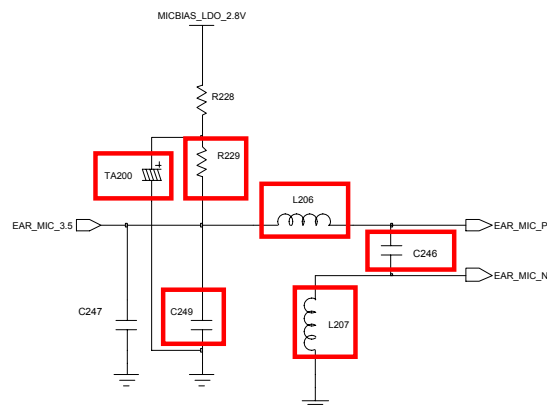
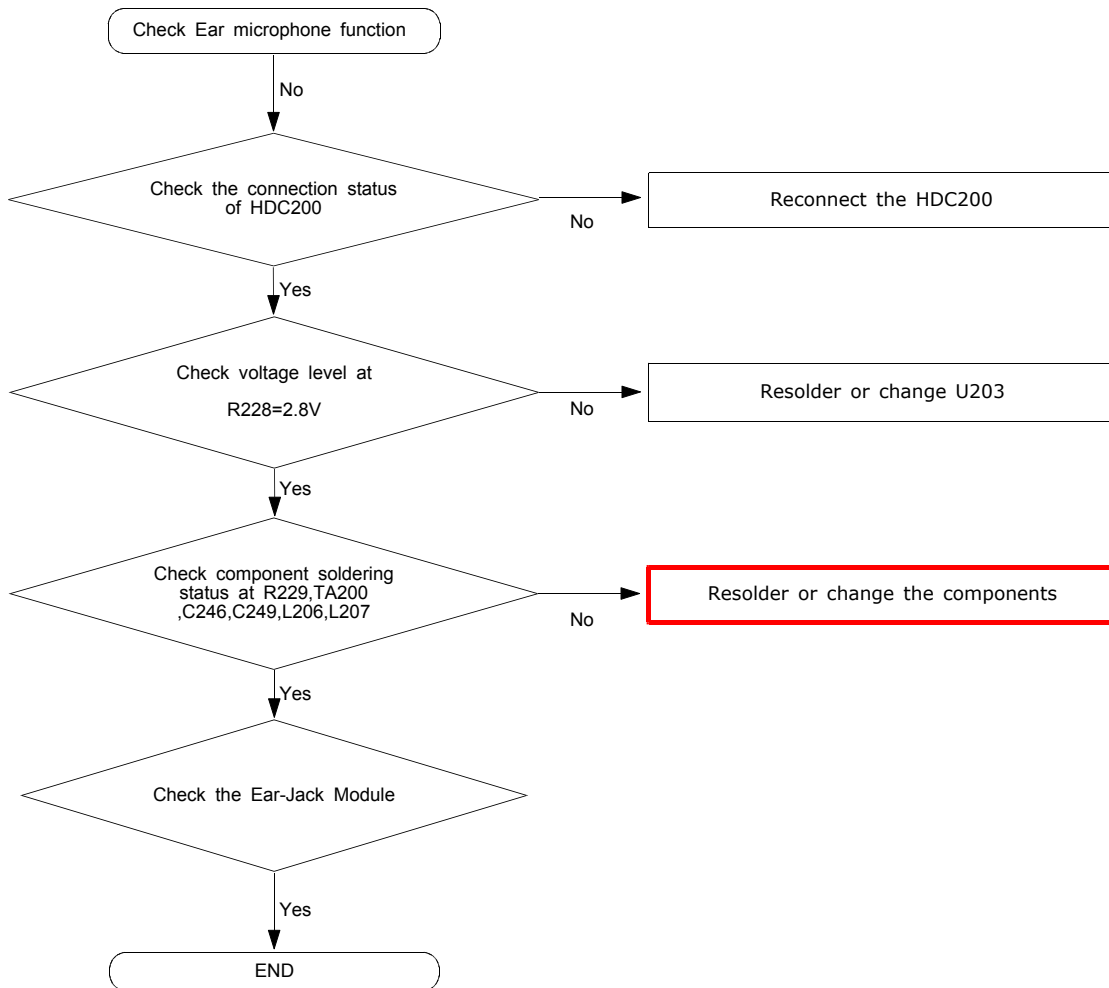

### 8-3-6. SPK Part

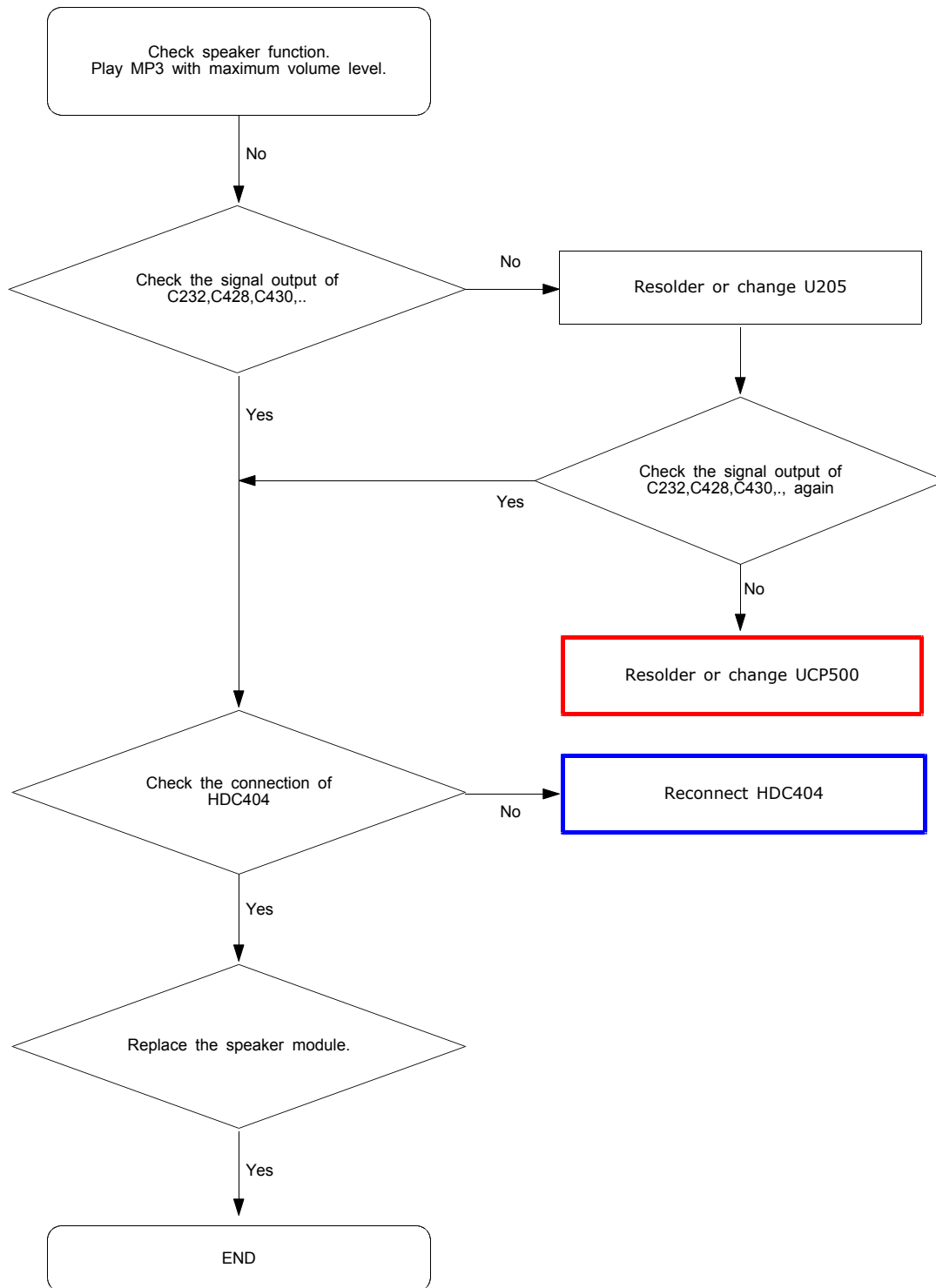

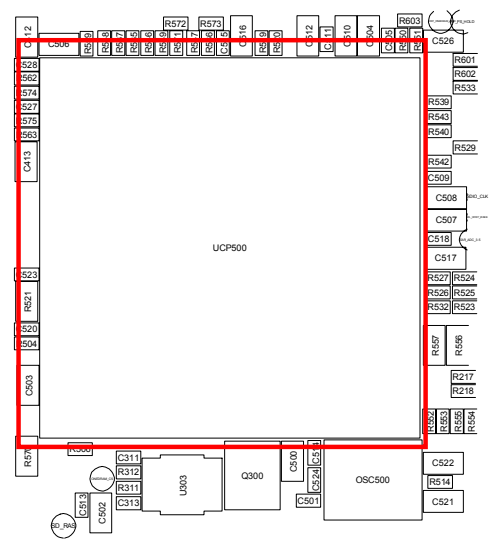
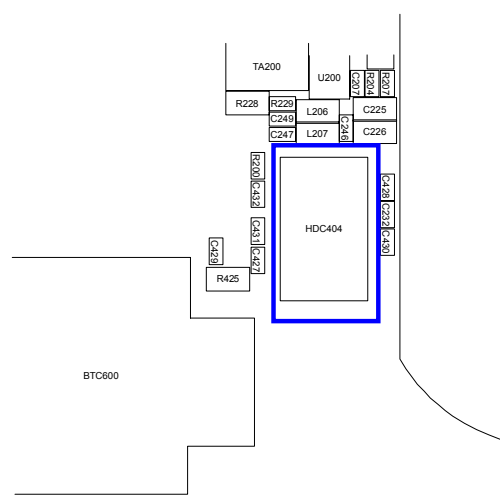
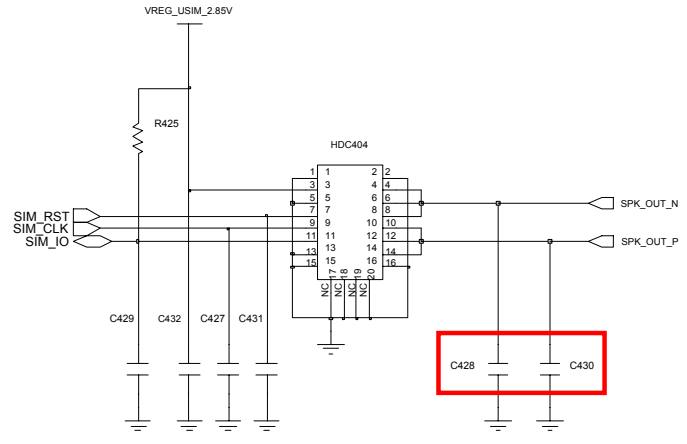
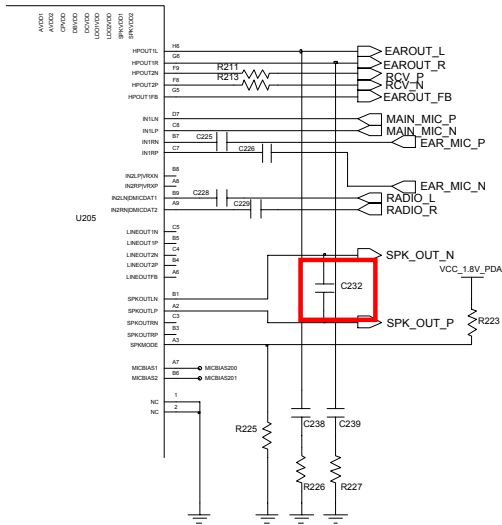

### 8-3-7. Receiver Part

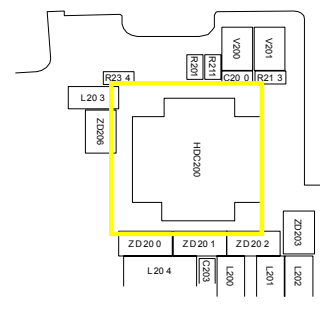
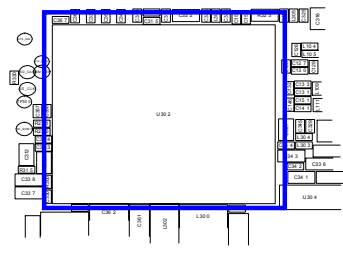
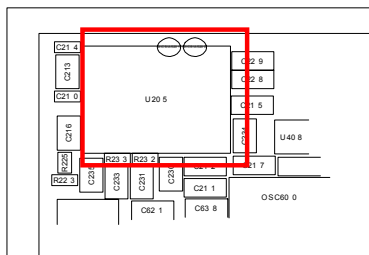
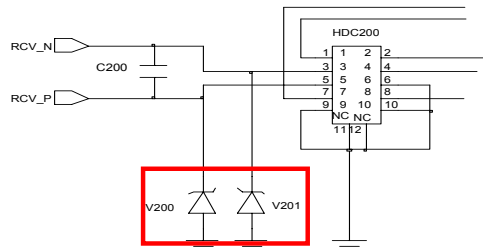
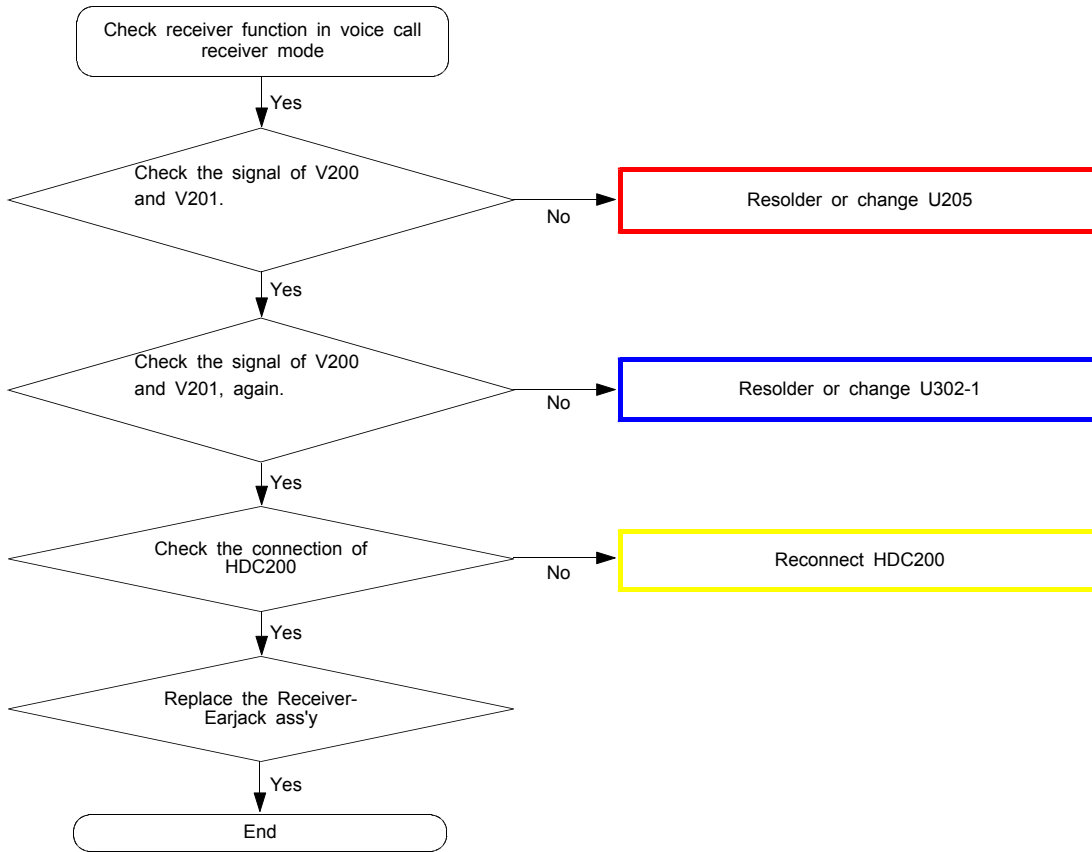

8-3-8. BT/WIFI

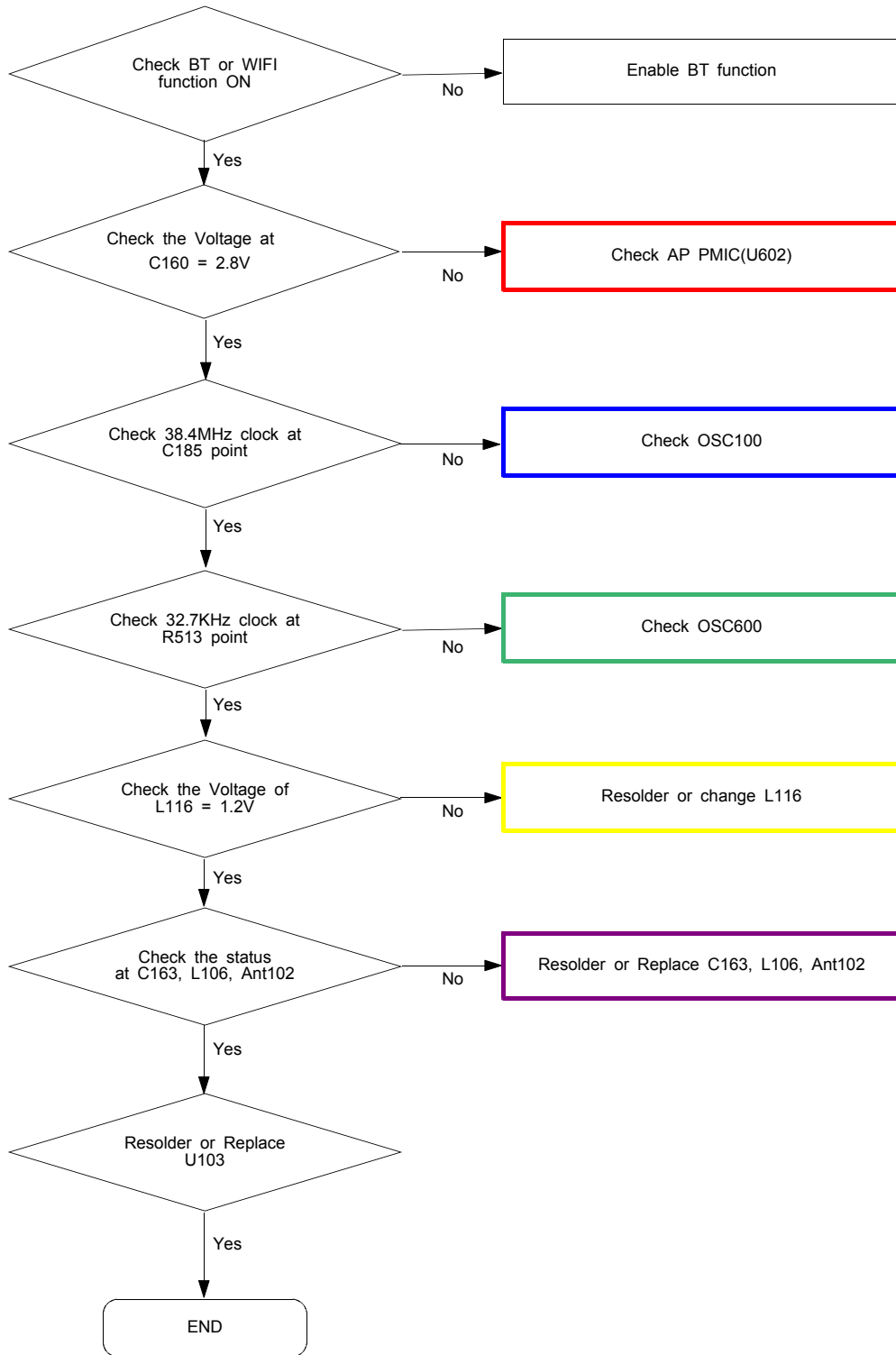



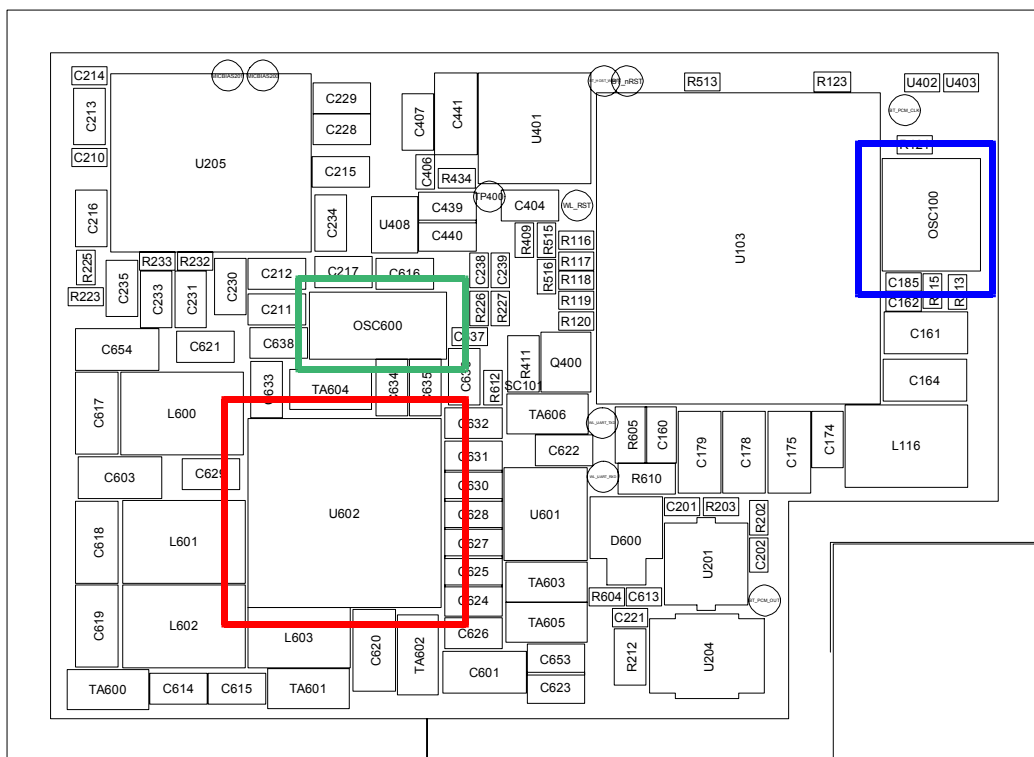
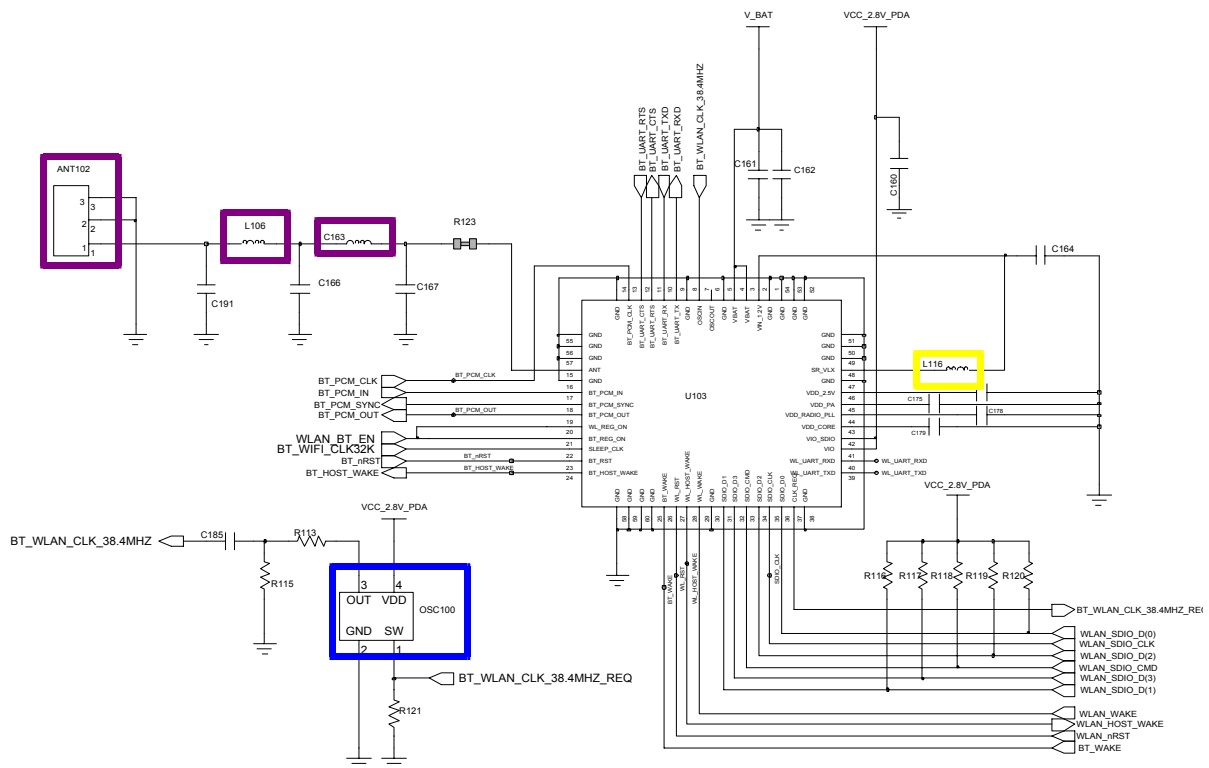

### 8-3-9. FM radio

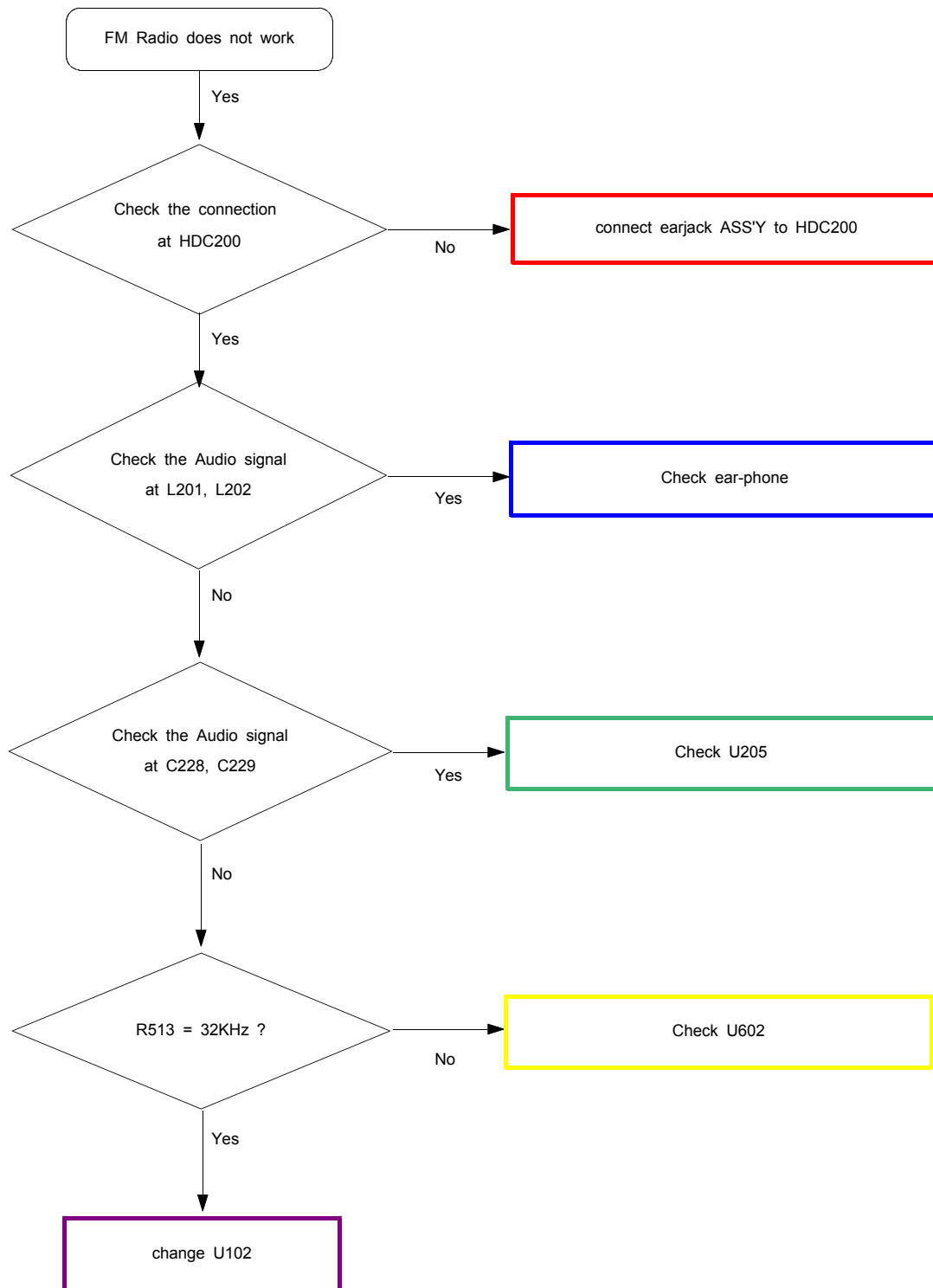

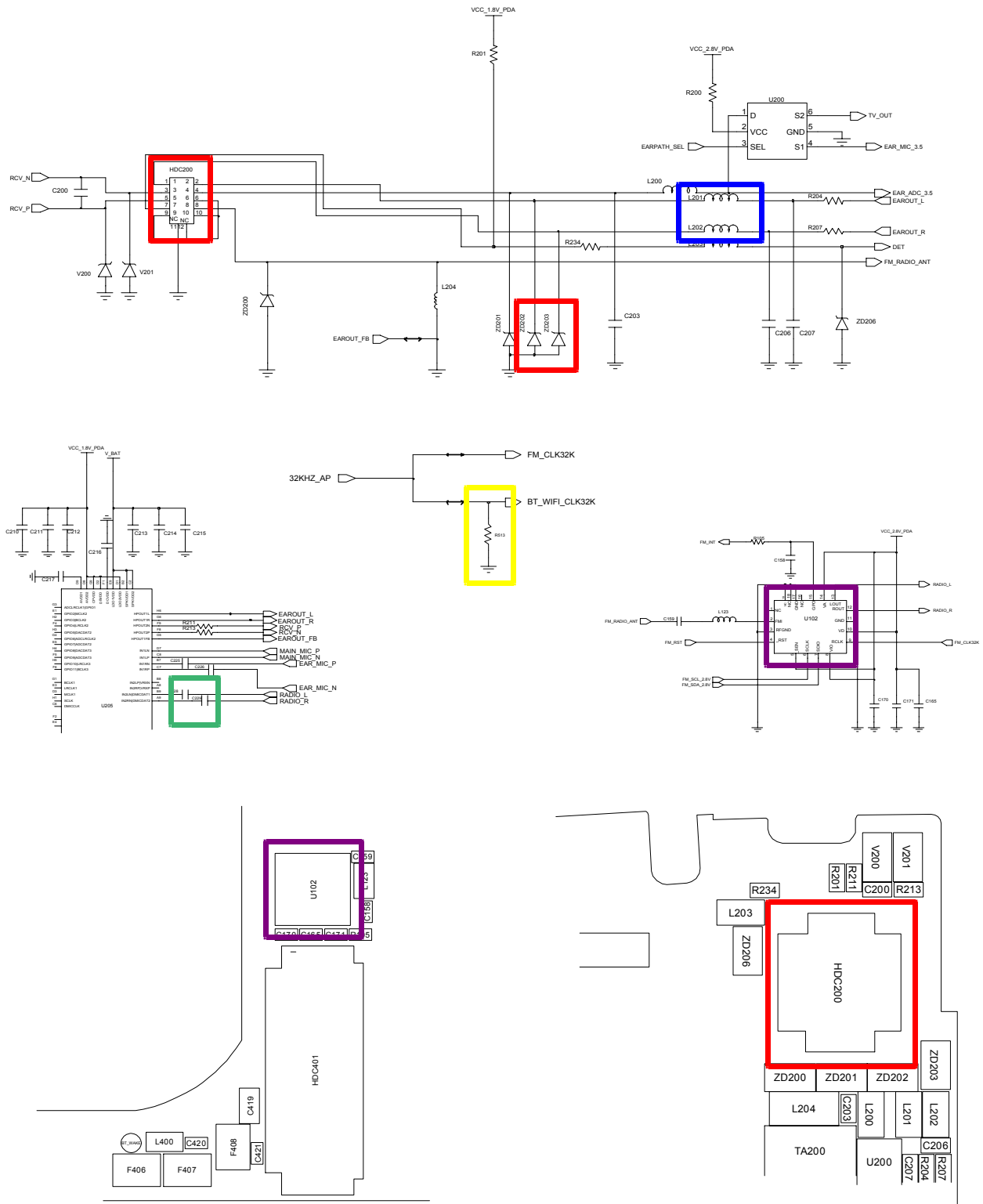

8-3-10. LCD

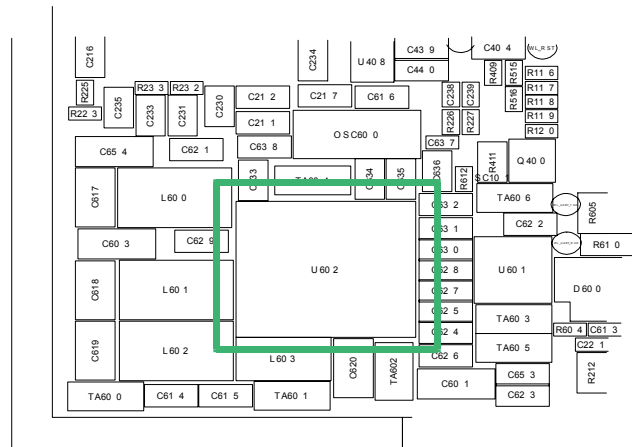
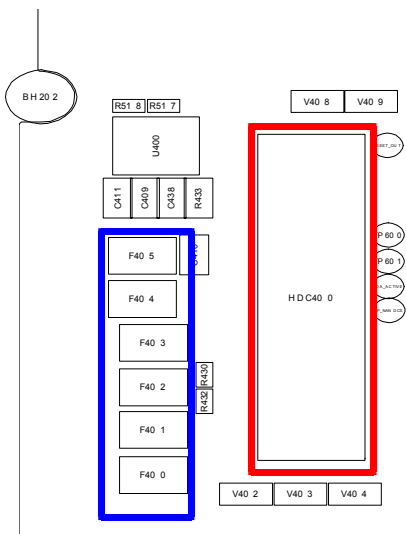
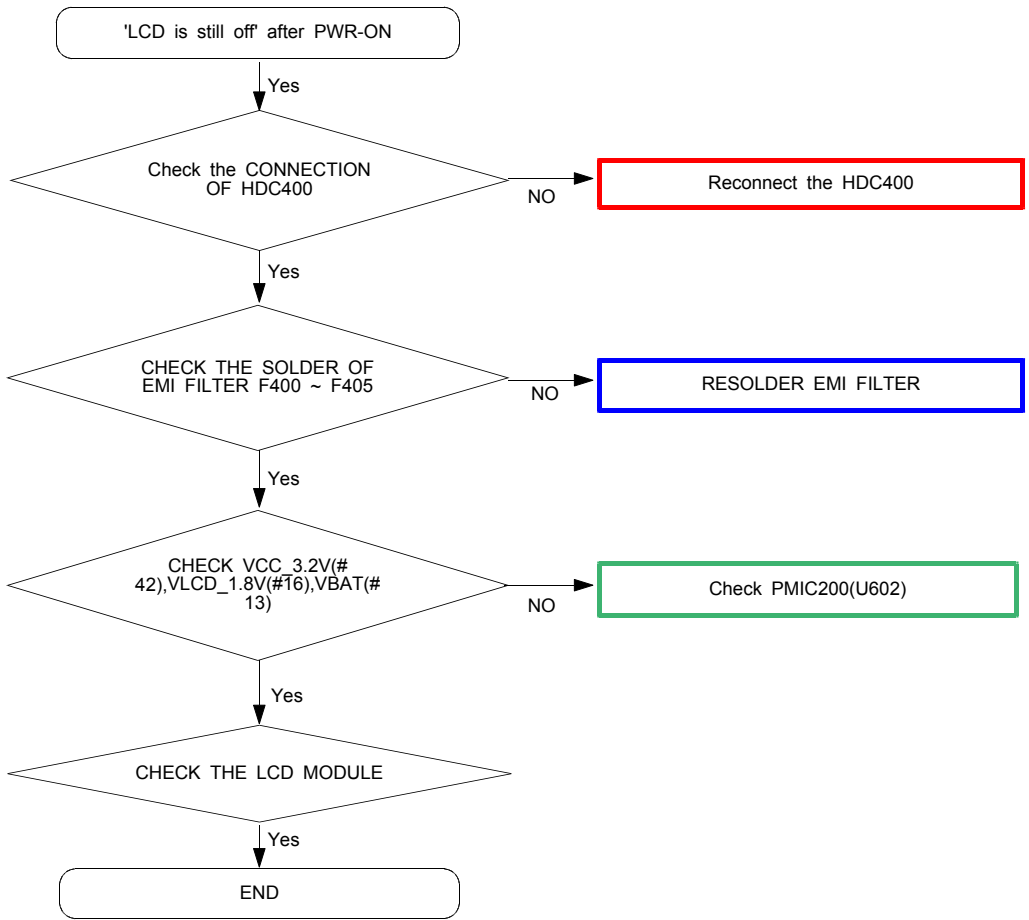

8-3-11. TSP

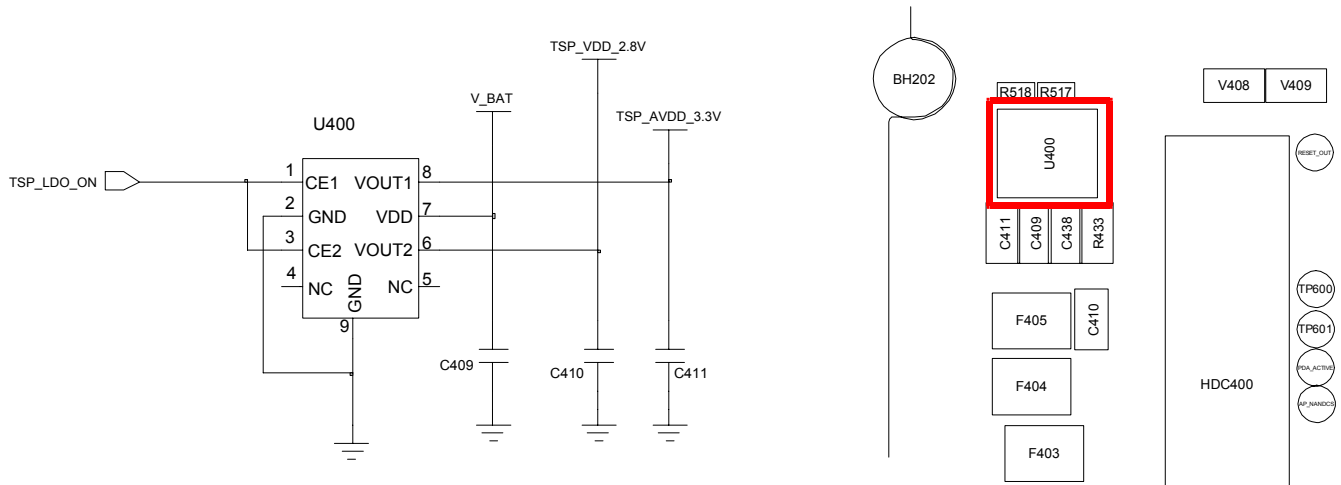
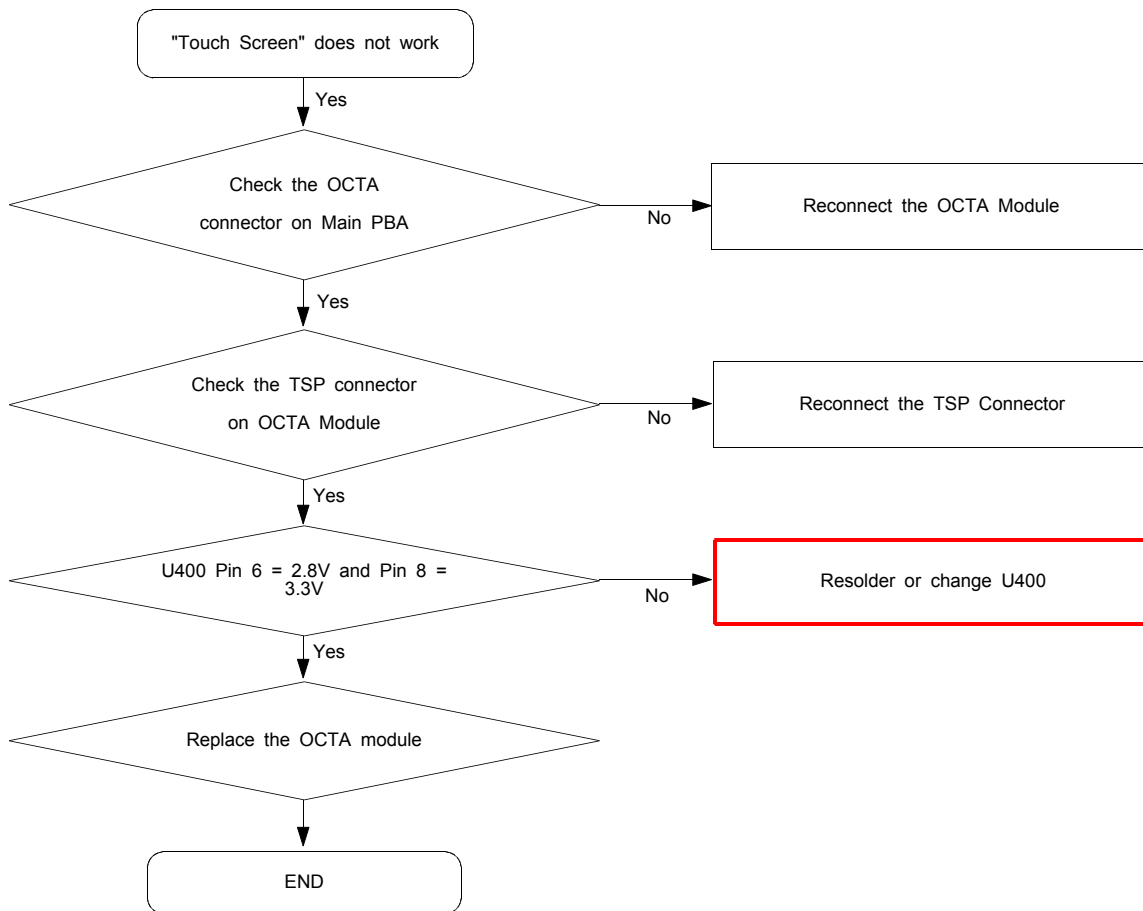

8-3-12. 5M CAM

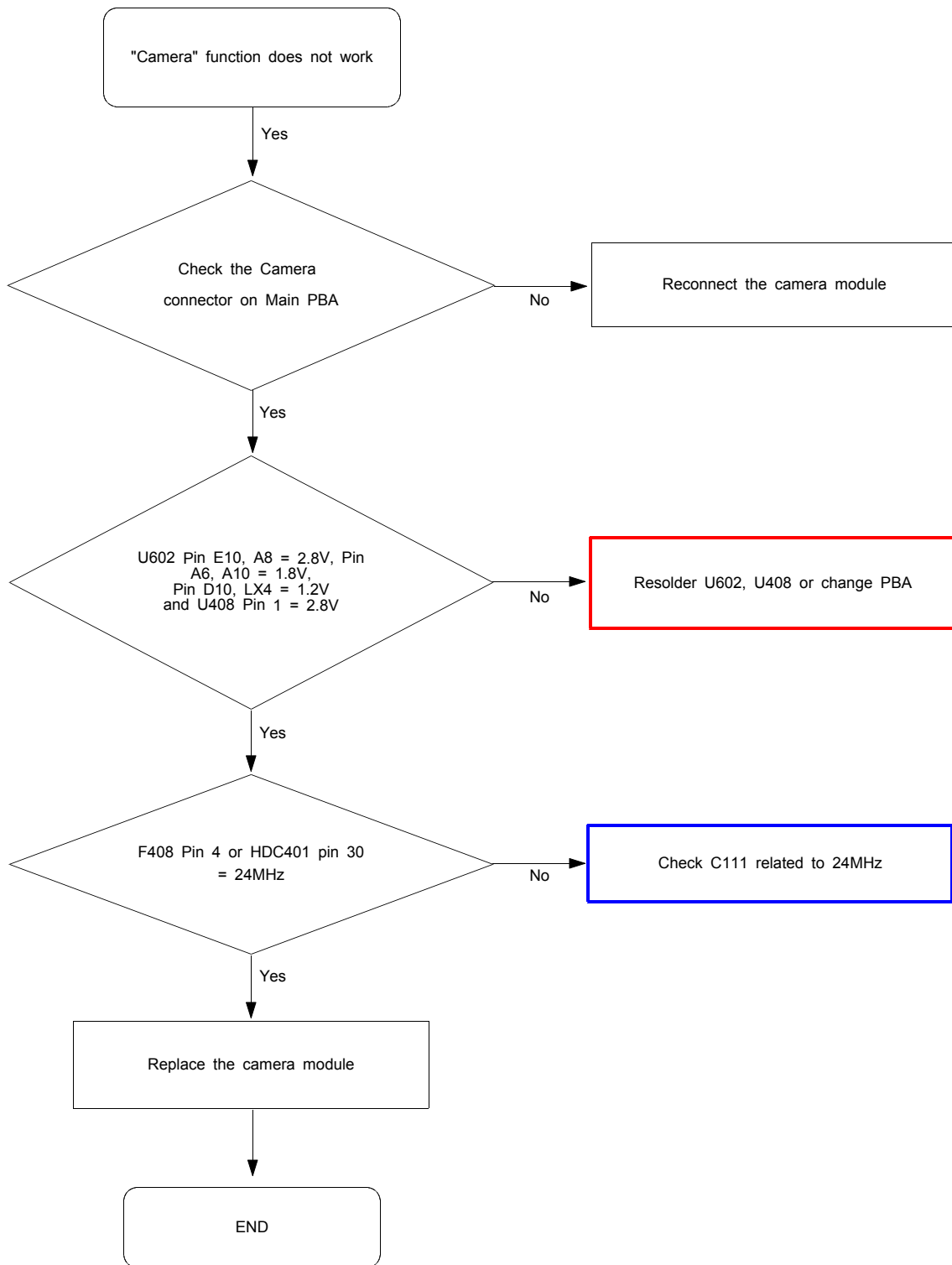



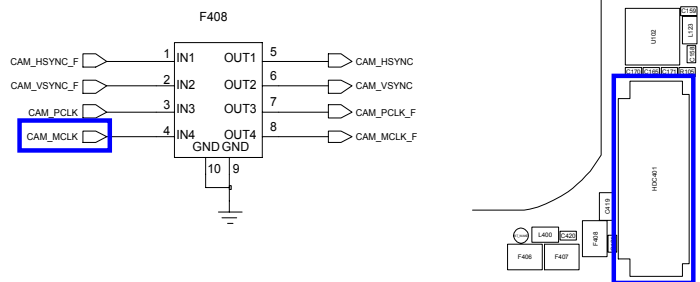
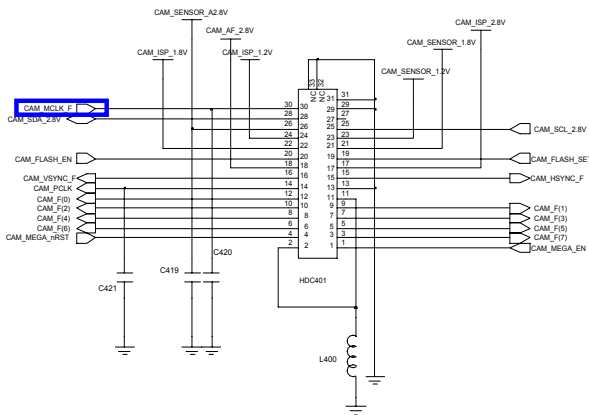
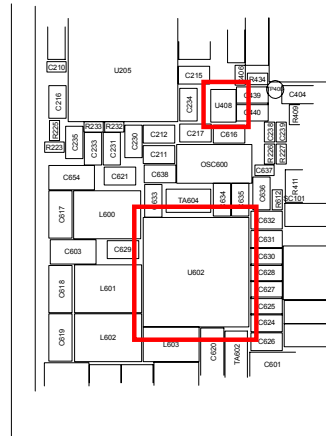
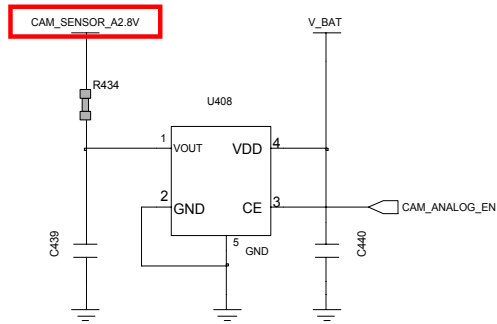
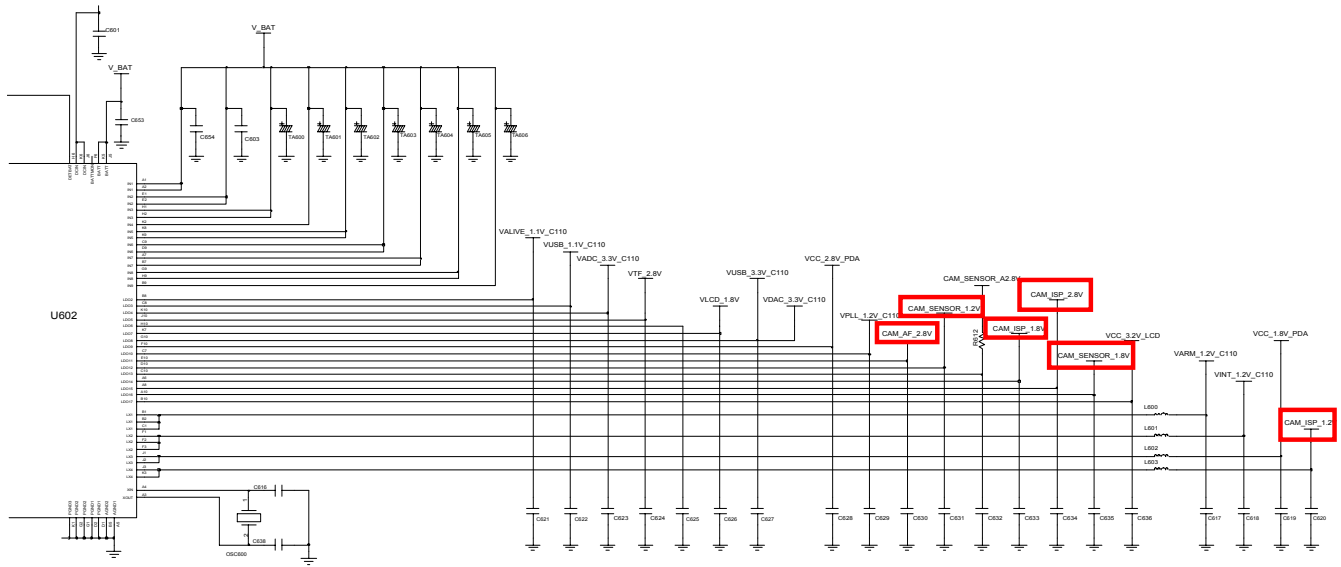

8-3-13. GSM850 RX

CONTINUOUS RX ON  
 RF INPUT : 190CH  
 AMP : -50dBm

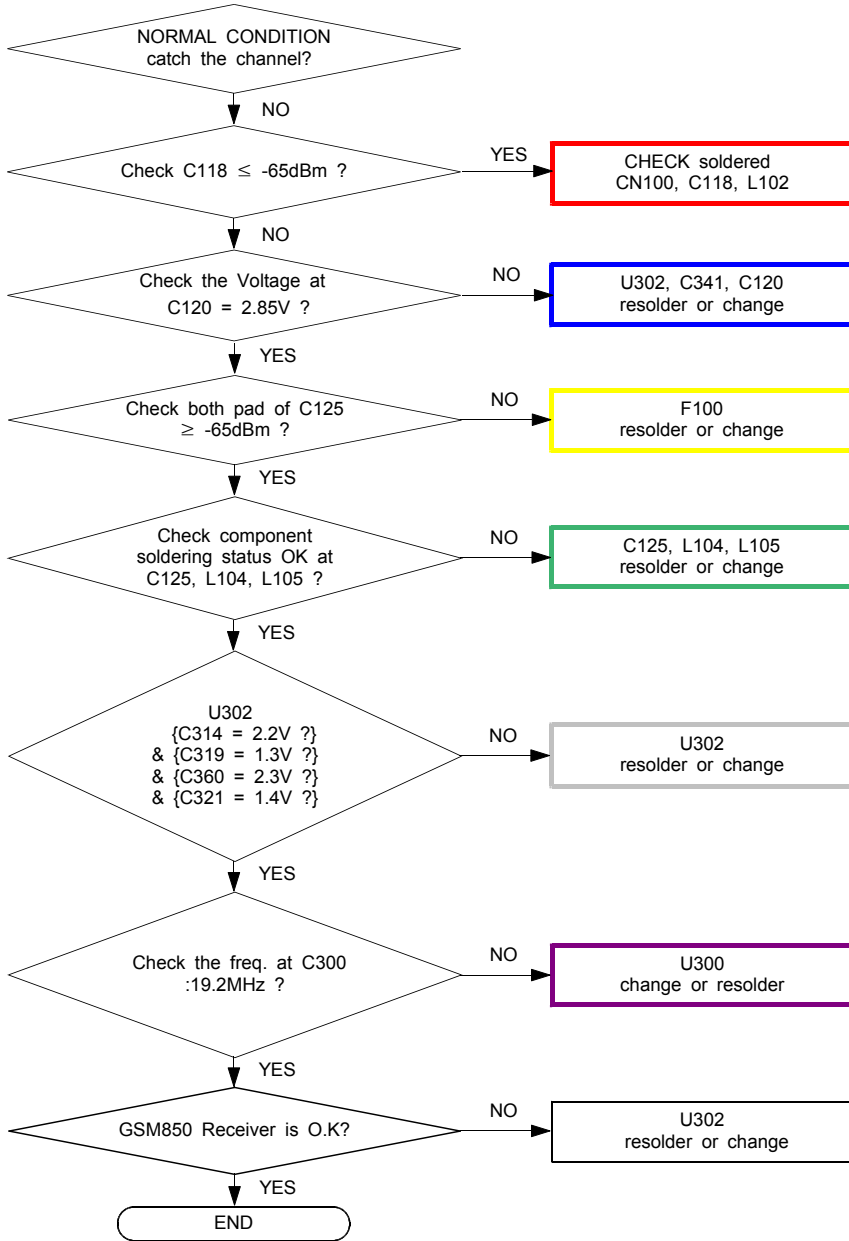

8-3-14. GSM900 RX

CONTINUOUS RX ON  
RF INPUT : 37CH  
AMP : -50dBm

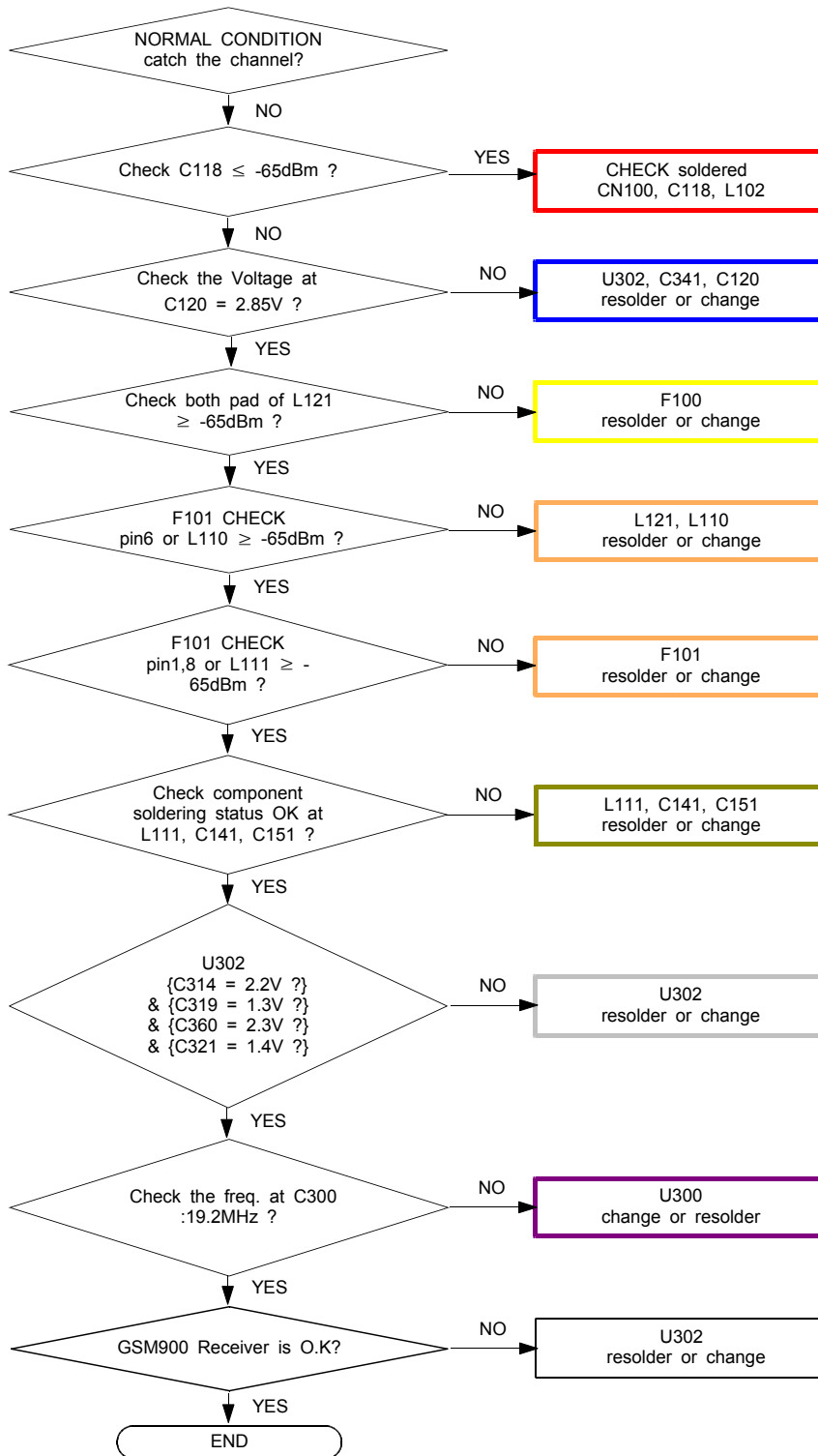

8-3-15. DCS/PCS RX

CONTINUOUS RX ON  
 DCS RF INPUT : 698CH  
 PCS RF INPUT : 661CH  
 AMP : -50dBm

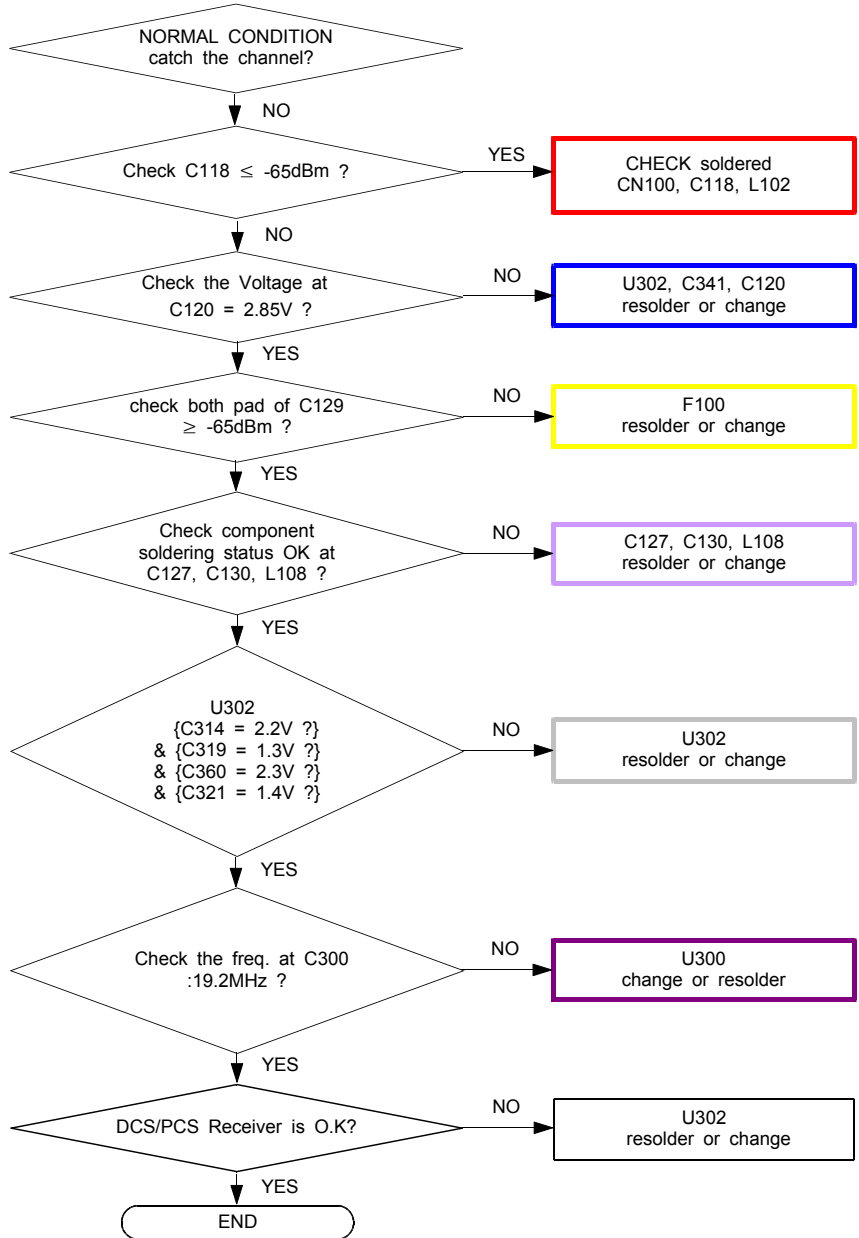



8-3-16. WCDMA Band1 RX

CONTINUOUS RX ON  
RF INPUT : 10700CH  
AMP : -50dBm

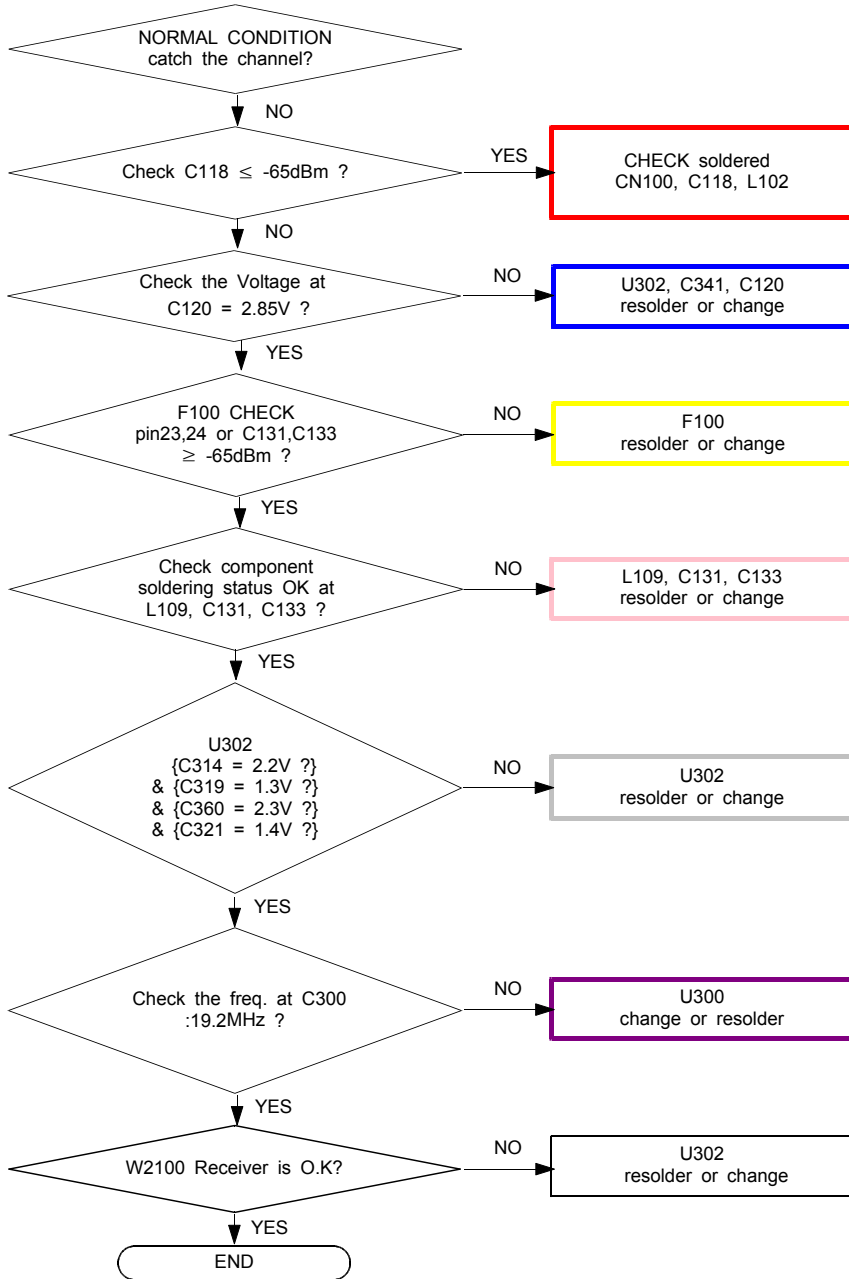

8-3-17. WCDMA Band8 RX

CONTINUOUS RX ON  
RF INPUT : 3013CH  
AMP : -50dBm

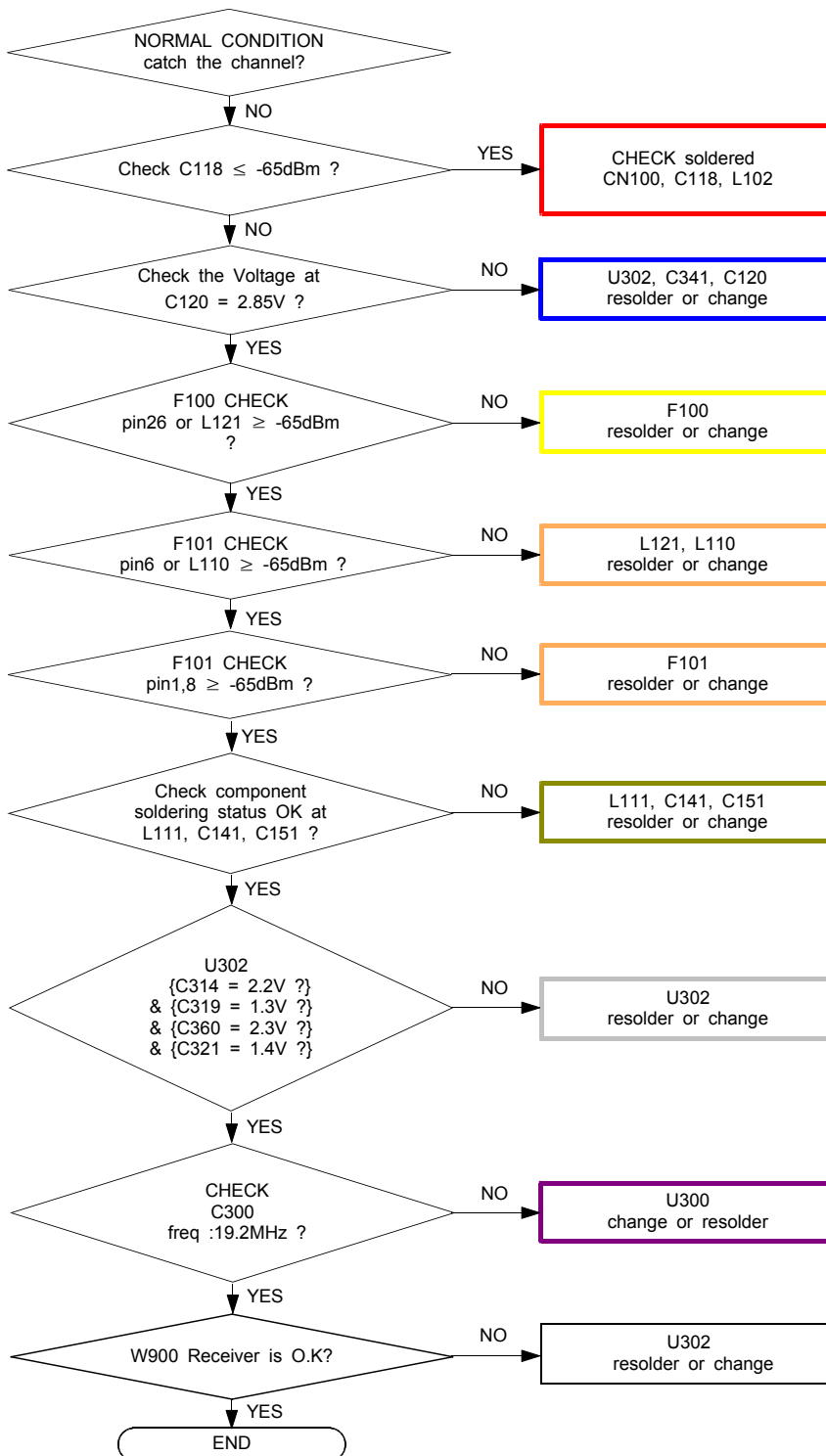



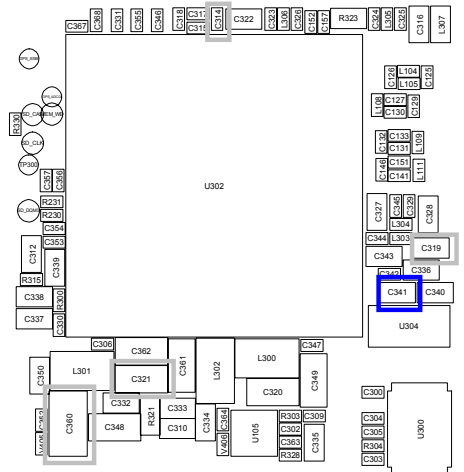
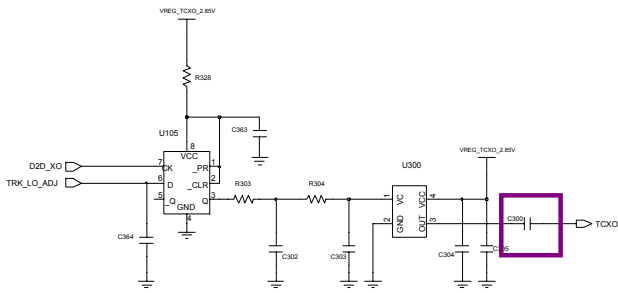
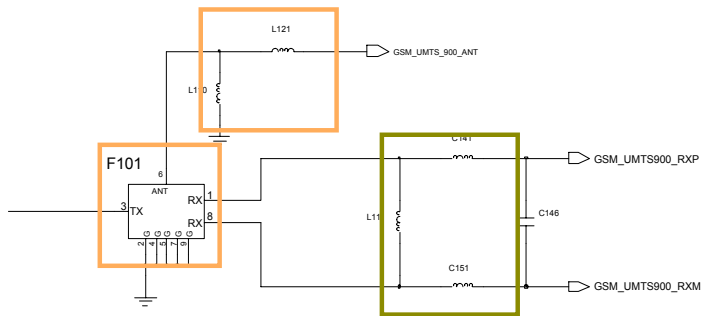
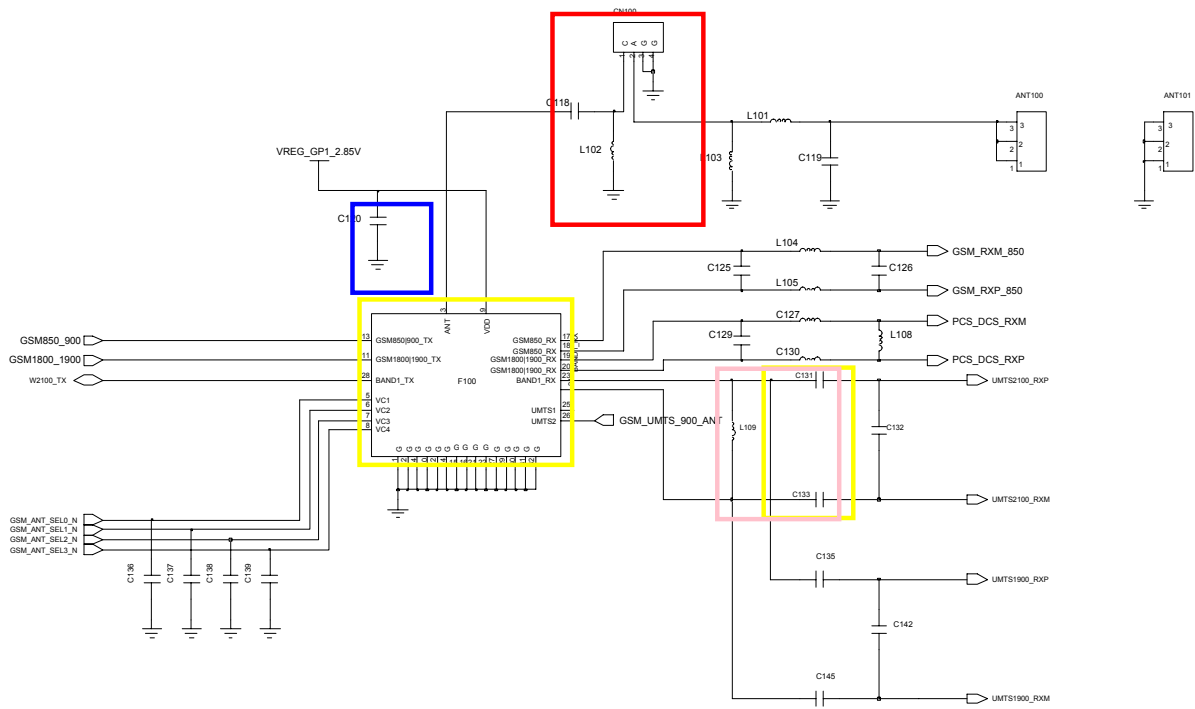

8-3-18. GSM850/900 TX

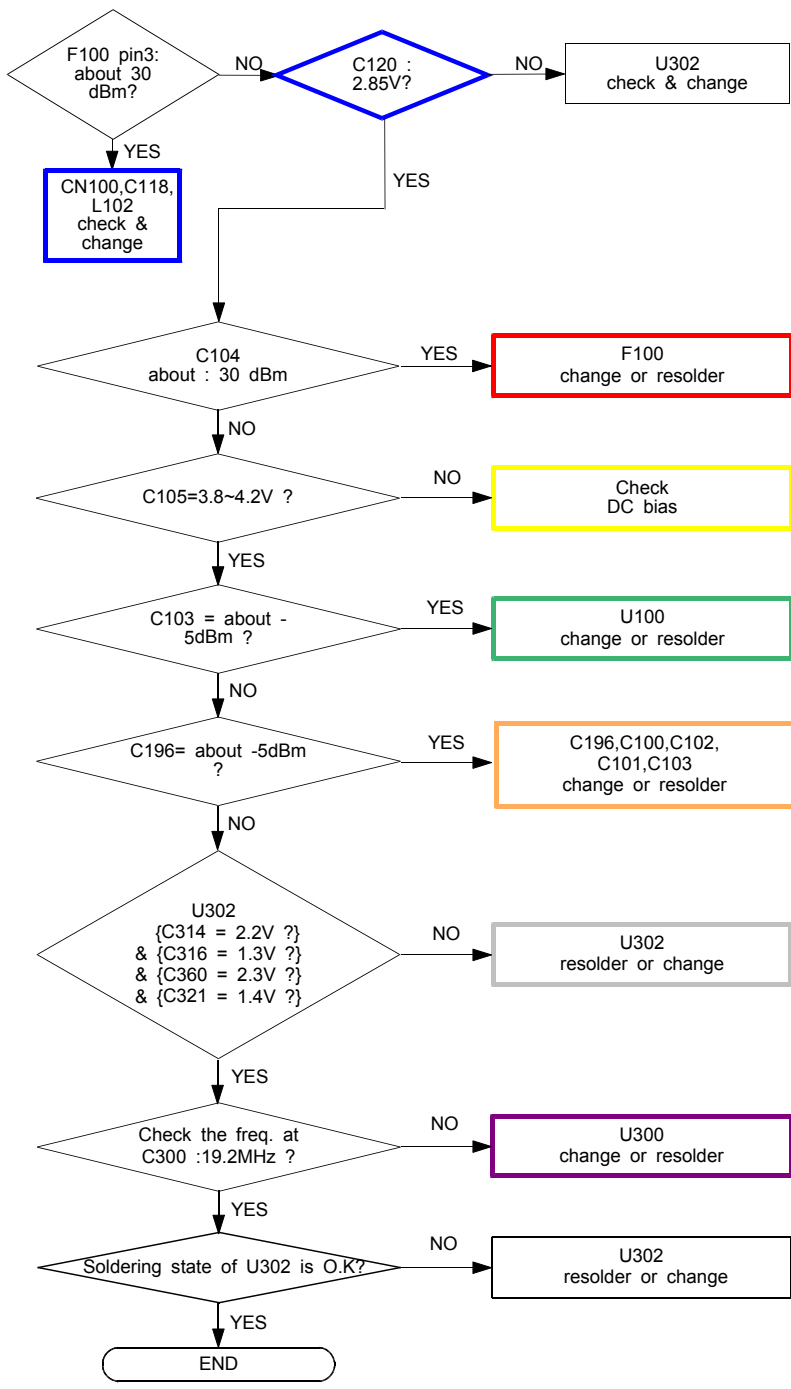

CONTINUOUS TX ON CONDITION  
TX POWER DAC:14500 CODE  
APPLIED  
GSM850 CH : 190  
GSM900 CH : 62  
RBW : 100KHz  
VBW : 100KHz  
SPAN : 10MHz  
REF LEV. : 10dBm  
ATT. : 20dB

8-3-19. DCS/PCS TX

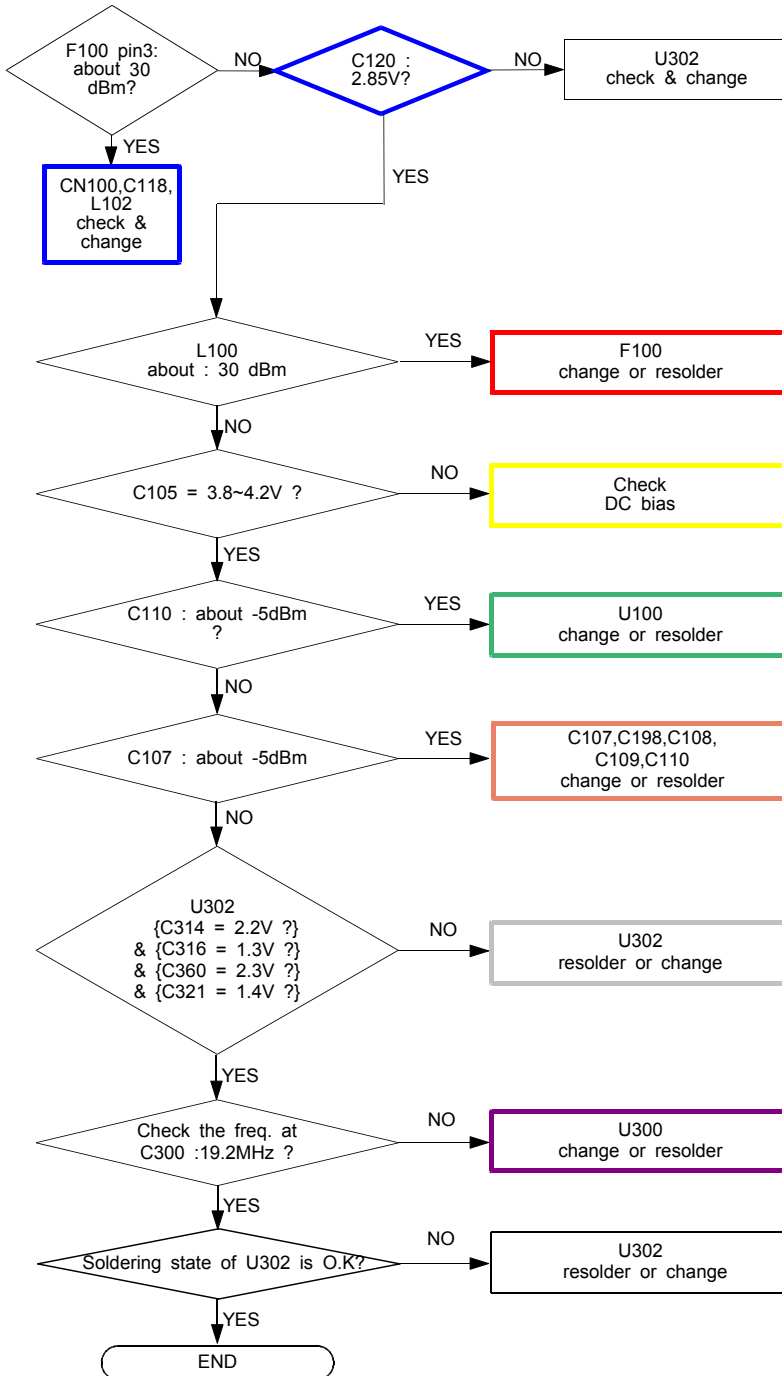

CONTINUOUS TX ON CONDITION  
TX POWER DAC:14500 CODE  
APPLIED  
DCS CH : 698  
PCS CH : 661  
RBW : 100KHz  
VBW : 100KHz  
SPAN : 10MHz  
REF LEV. : 10dBm  
ATT. : 20dB

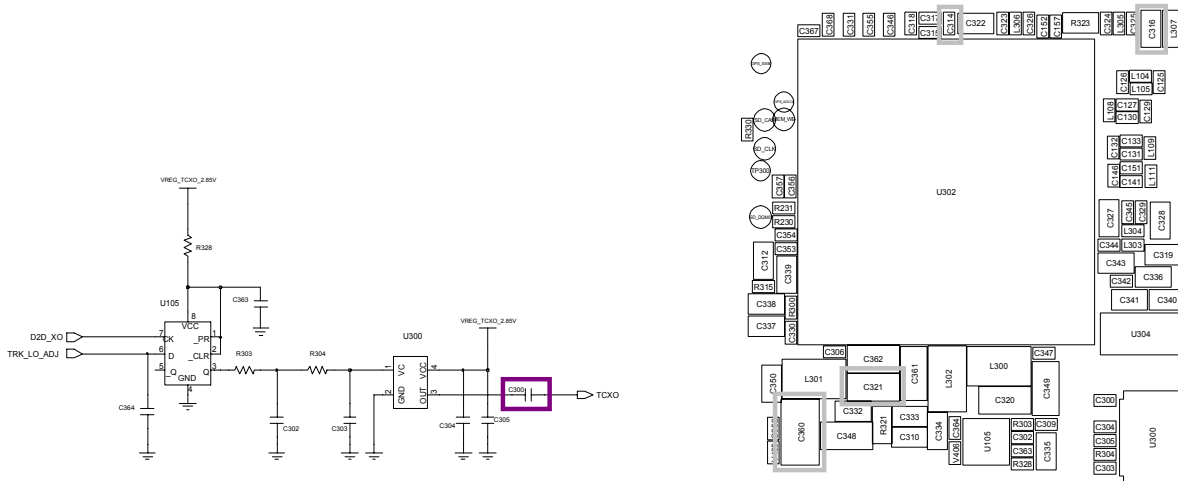
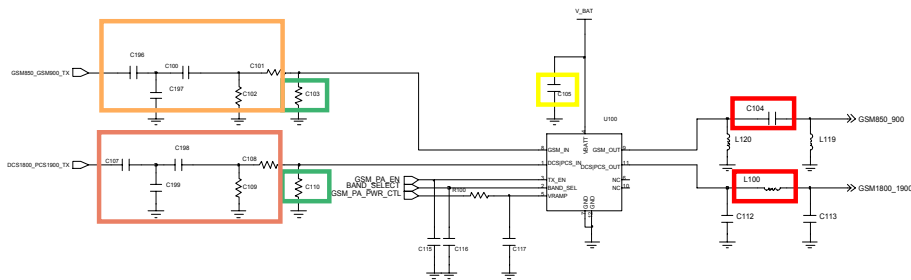
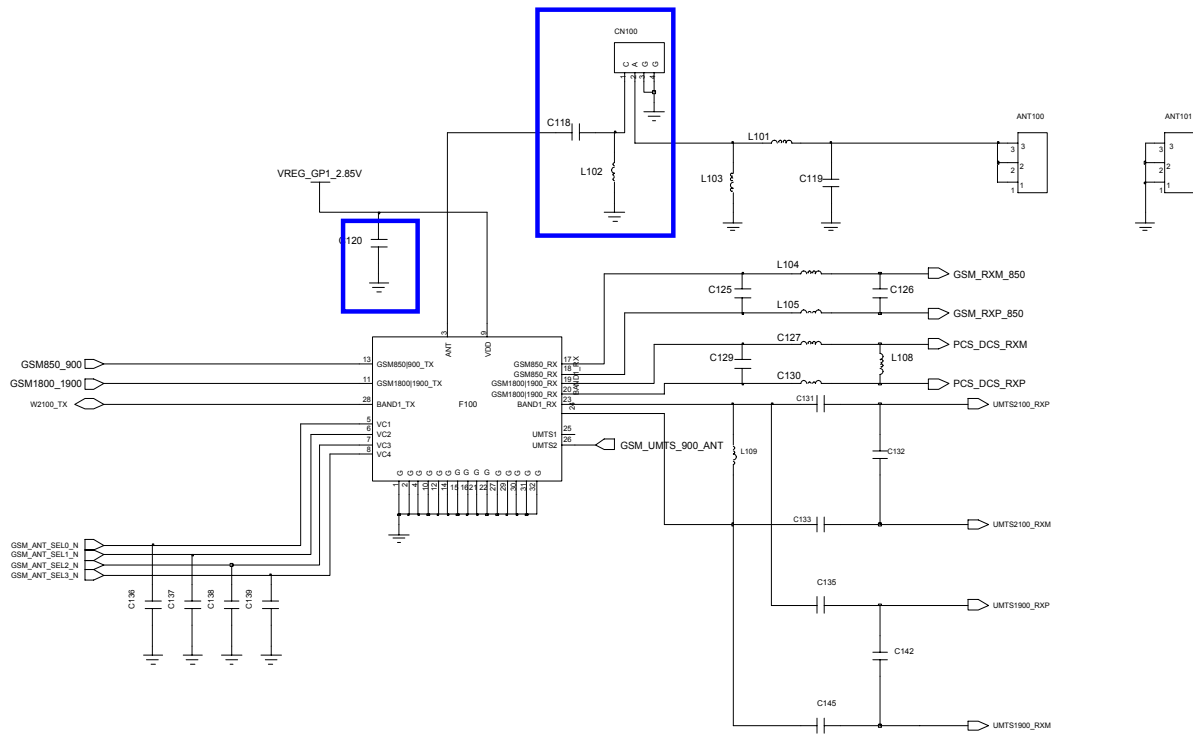

8-3-20. WCDMA Band1 TX

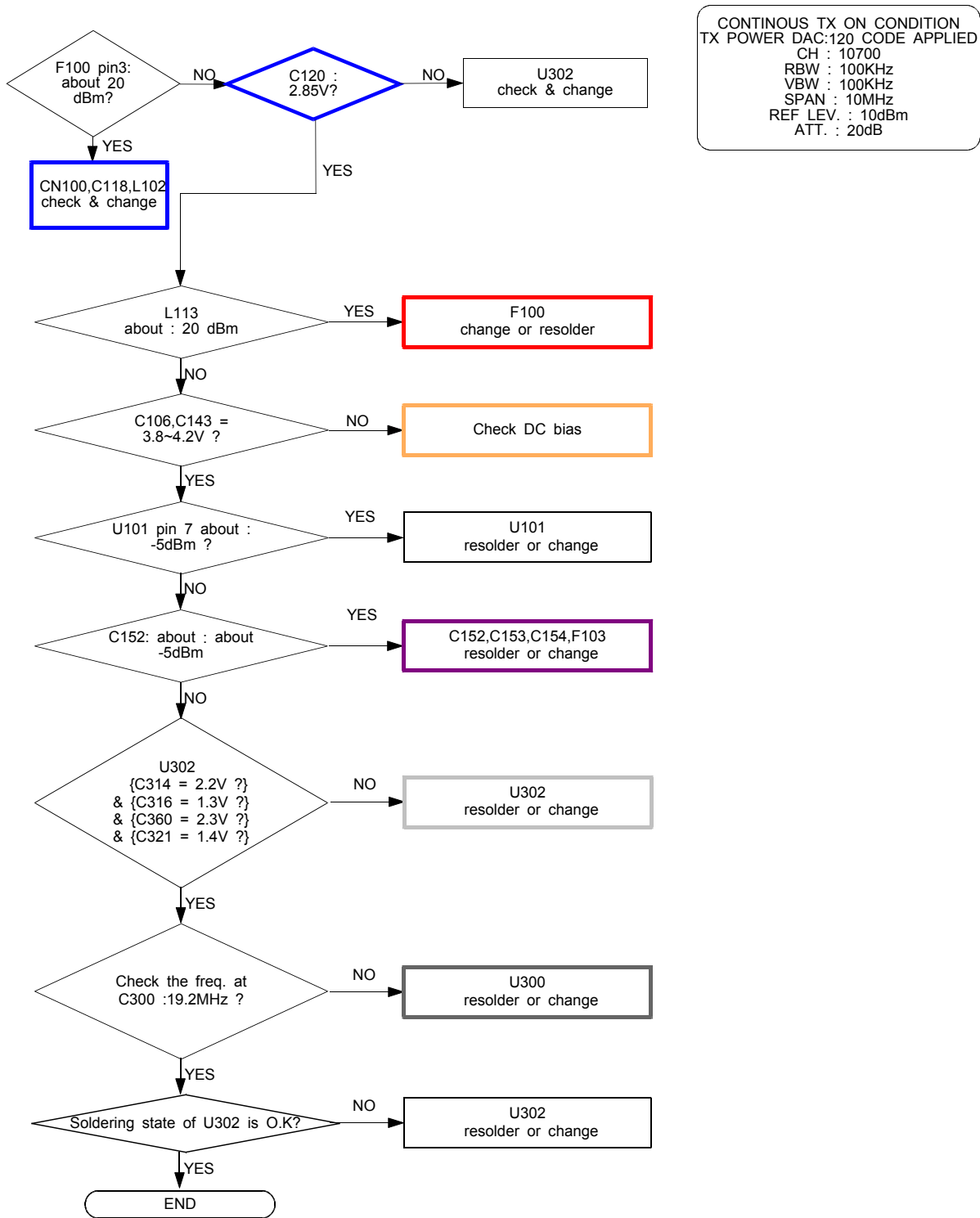

CONTINUOUS TX ON CONDITION  
 TX POWER DAC:120 CODE APPLIED  
 CH : 10700  
 RBW : 100KHz  
 VBW : 100KHz  
 SPAN : 10MHz  
 REF LEV. : 10dBm  
 ATT. : 20dB

8-3-21. WCDMA Band8 TX

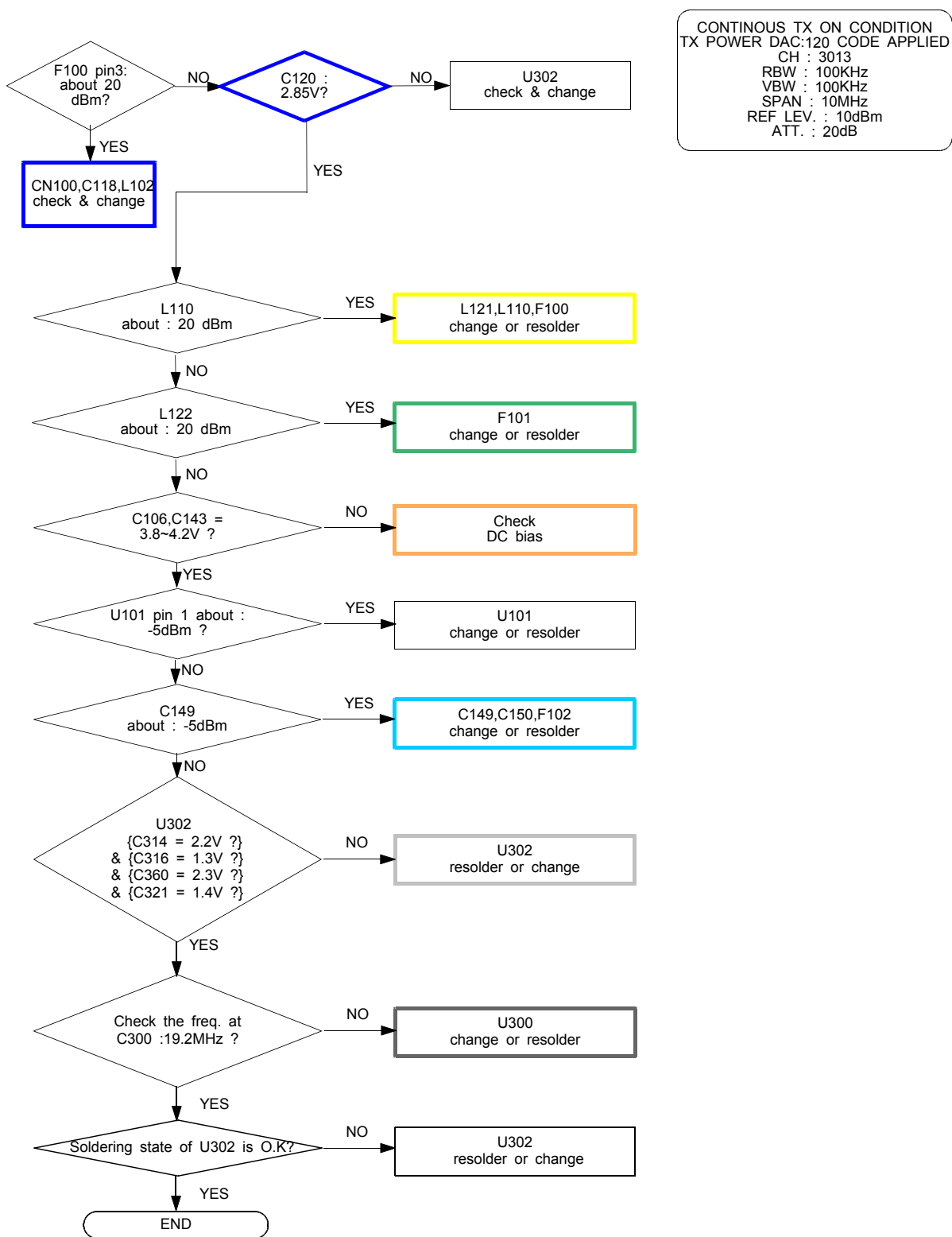

CONTINUOUS TX ON CONDITION  
 TX POWER DAC:120 CODE APPLIED  
 CH : 3013  
 RBW : 100KHz  
 VBW : 100KHz  
 SPAN : 10MHz  
 REF LEV. : 10dBm  
 ATT. : 20dB

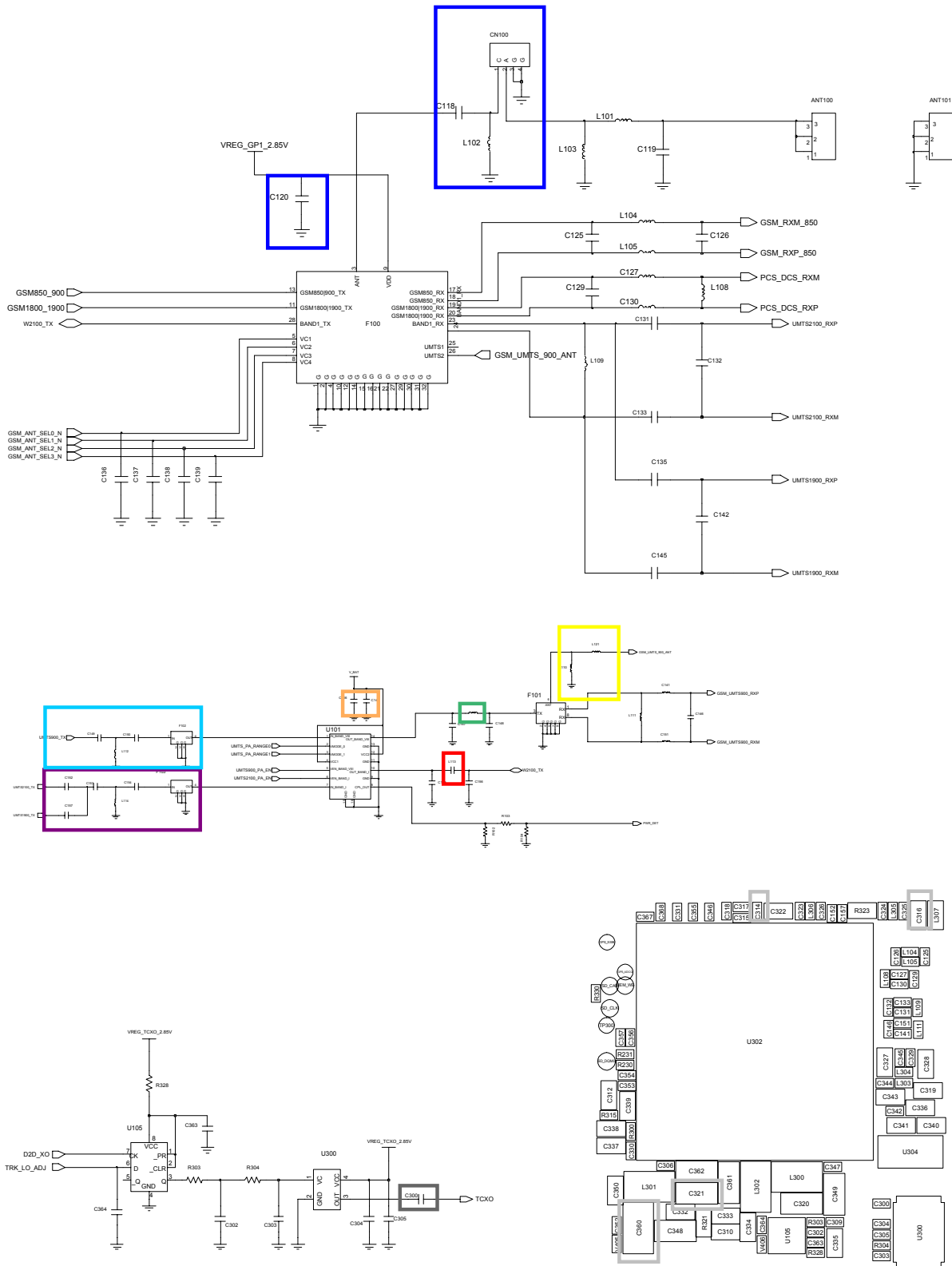

8-4. Service Schematics

- NC Point(Top View)

● : NC

UME200

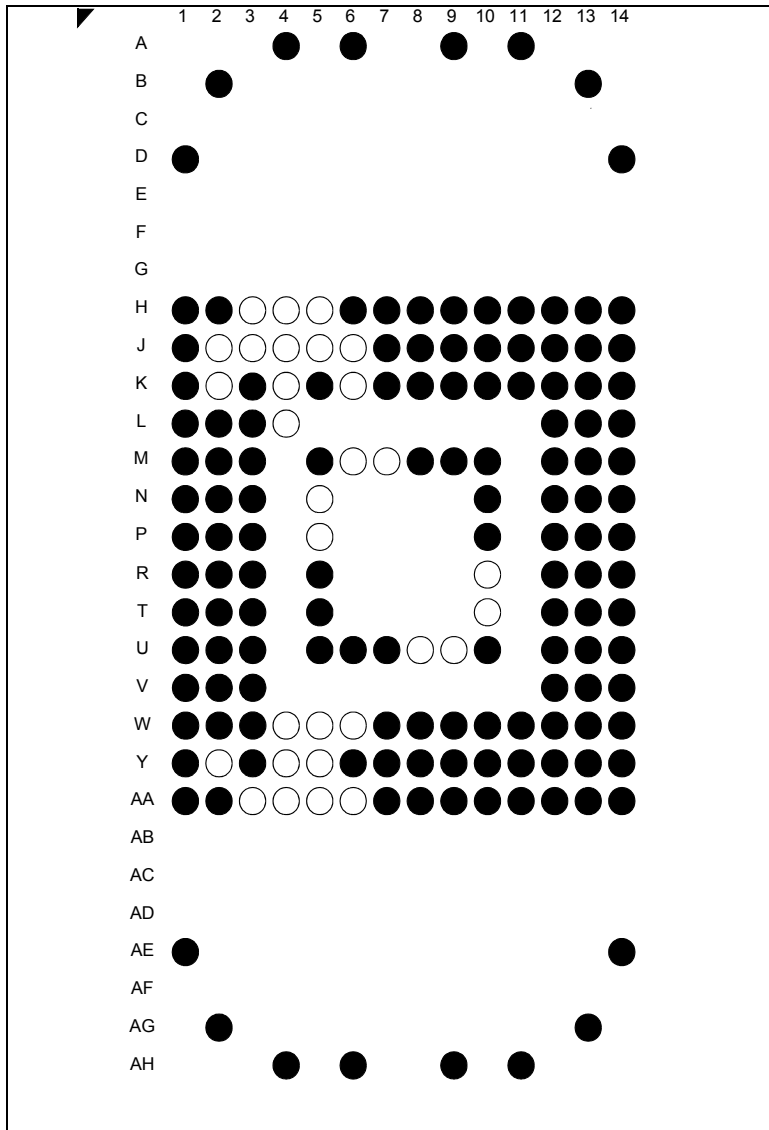



■ : NC

UCP500

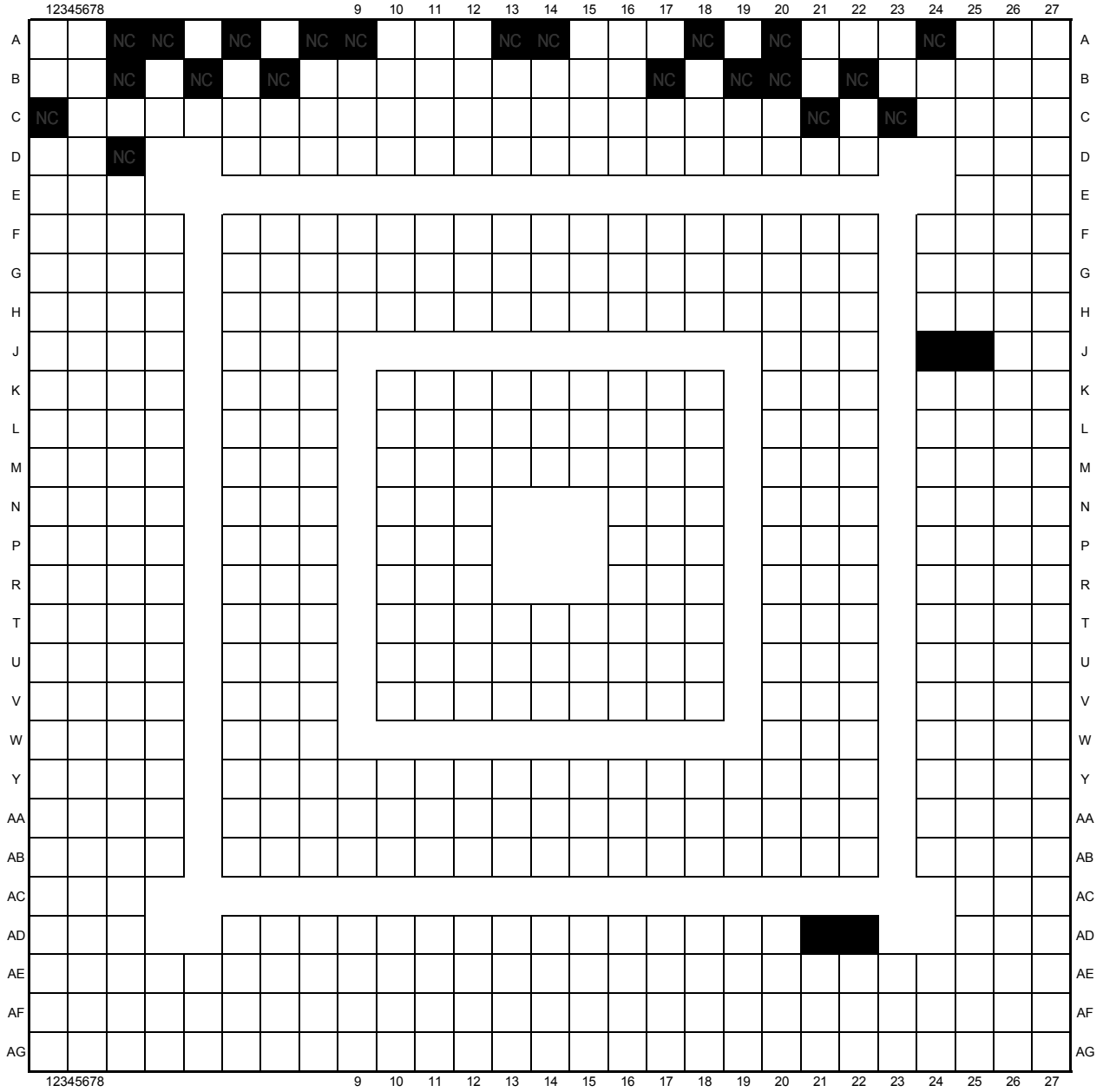

■ : NC

U302

	1	2	3	4	5	6	7	8	9	10	11	12	13	14	15	16	17	18	19	20	21	22	23	
A																								A
B																								B
C																								C
D																								D
E																								E
F																								F
G																								G
H																								H
J																								J
K																								K
L																								L
M																								M
N																								N
P																								P
R																								R
T																								T
U																								U
V																								V
W																								W
Y																								Y
AA																								AA
AB																								AB
AC																								AC
	1	2	3	4	5	6	7	8	9	10	11	12	13	14	15	16	17	18	19	20	21	22	23	