

**SAMSUNG**

# GSM TELEPHONE

## SGH-L170

# **SERVICE** *Manual*

### GSM TELEPHONE

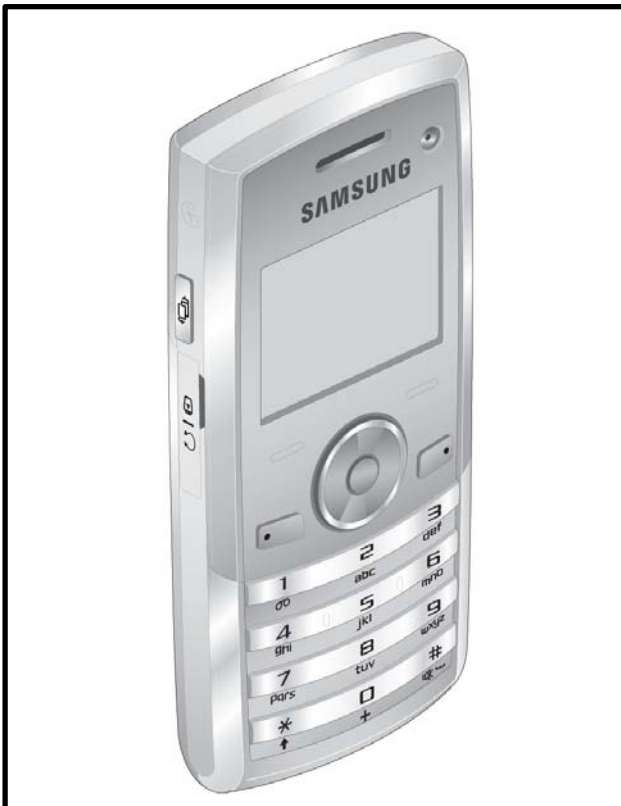

### CONTENTS

1. Safety Precautions
2. Specification
3. Product Function
4. Array course control
5. Exploded View and Parts list
6. MAIN Electrical Parts List
7. Disassembly and Assembly Instructions
8. Block Diagrams
9. PCB Diagrams
10. Chart of Troubleshooting
11. Reference data

**SAMSUNG  
ELECTRONICS**



GSPN (Global Service Partner Network)

<b>Country</b>	<b>Web Site</b>
North America	<a href="http://service.samsungportal.com">service.samsungportal.com</a>
Latin America	<a href="http://latin.samsungportal.com">latin.samsungportal.com</a>
CIS	<a href="http://cis.samsungportal.com">cis.samsungportal.com</a>
Europe	<a href="http://europe.samsungportal.com">europe.samsungportal.com</a>
China	<a href="http://china.samsungportal.com">china.samsungportal.com</a>
Asia	<a href="http://asia.samsungportal.com">asia.samsungportal.com</a>
Mideast & Africa	<a href="http://mea.samsungportal.com">mea.samsungportal.com</a>

## 2. Specification

### 2-1. GSM General Specification

		EGSM 900	DCS1800	PCS1900	WCDMA
Freq. Band[MHz] Uplink/Downlink		880~915 925~960	1710~1785 1805~1880	1850~1910 1930~1990	1920~1980 2110~2170
ARFCN range		0~124 & 975~1023	512~885	512~810	UL:9612~9888 DL:10562~10838
Tx/Rx spacing		45MHz	95MHz	80MHz	190MHz
Mod. Bit rate/ Bit Period		270.833kbps 3.692us	270.833kbps 3.692us	270.833kbps 3.692us	3.84Mcps
Time Slot Period/Frame Period		576.9us 4.615ms	576.9us 4.615ms	576.9us 4.615ms	Frame length : 10ms Slot length : 0.667ms
Modulation	GSM/ GPRS	0.3GMSK	0.3GMSK	0.3GMSK	QPSK HQPSK
	EDGE	8PSK	8PSK	8PSK	
MS Power		33dBm~5dBm	30dBm~0dBm	30dBm~0dBm	24dBm ~ - 50dBm
Power Class		4 (max +33dBm)	1 (max +30dBm)	1 (max +30dBm)	3 (max +24dBm)
Sensitivity		-102dBm	-100dBm	-100dBm	-106.7dBm
TDMA Mux		8	8	8	
Cell Radius		35Km	2Km	2Km	2Km

## 2-2. GSM TX power class

<b>TX Power control level</b>	<b>GSM900</b>	<b>TX Power control level</b>	<b>DCS1800</b>	<b>TX Power control level</b>	<b>PCS1900</b>
5	33±2 dBm	0	30±2 dBm	0	30±2 dBm
6	31±2 dBm	1	28±3 dBm	1	28±3 dBm
7	29±2 dBm	2	26±3 dBm	2	26±3 dBm
8	27±2 dBm	3	24±3 dBm	3	24±3 dBm
9	25±2 dBm	4	22±3 dBm	4	22±3 dBm
10	23±2 dBm	5	20±3 dBm	5	20±3 dBm
11	21±2 dBm	6	18±3 dBm	6	18±3 dBm
12	19±2 dBm	7	16±3 dBm	7	16±3 dBm
13	17±2 dBm	8	14±3 dBm	8	14±3 dBm
14	15±2 dBm	9	12±4 dBm	9	12±4 dBm
15	13±2 dBm	10	10±4 dBm	10	10±4 dBm
16	11±3 dBm	11	8±4dBm	11	8±4dBm
17	9±3dBm	12	6±4 dBm	12	6±4 dBm
18	7±3 dBm	13	4±4 dBm	13	4±4 dBm
19	5±3 dBm	14	2±5 dBm	14	2±5 dBm
		15	0±5 dBm	15	0±5 dBm

---

## 5. Exploded View and Parts List

---

### 5-1. Cellular phone Exploded View

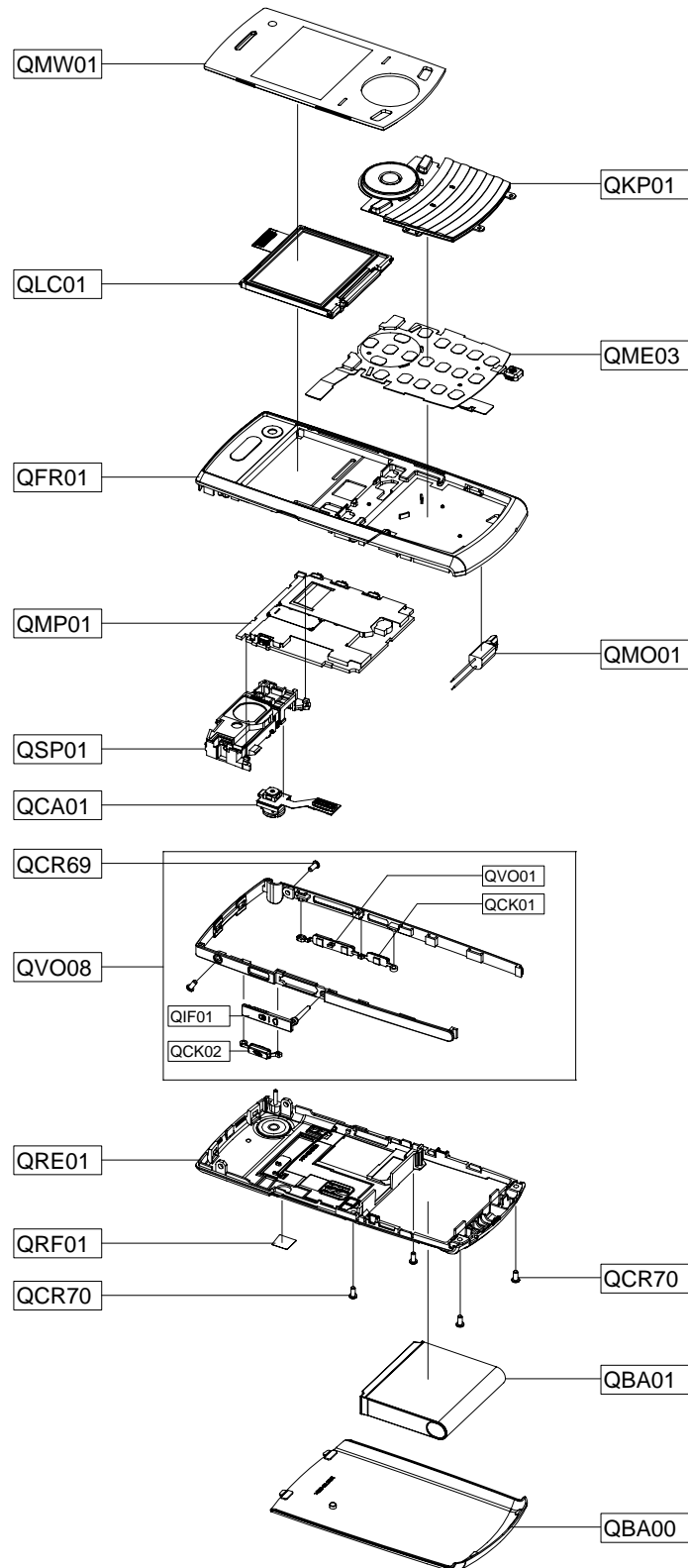





## 5-2. Cellular phone Parts list

Design LOC	Description	SEC CODE
QBA00	ASSY COVER-BATTERY	GH98-07254A
QBA01	INNER BATTERY PACK-880MAH , BL	GH43-02666A
QCA01	CAMERA MODULE-SGHL170 2M	GH59-05043A
QCK01	PMO KEY-CAM	GH72-44665A
QCR69	SCREW-MACHINE	6001-002065
QCR70	SCREW-TAPPING	6002-001402
QCR70	SCREW-TAPPING	6002-001402
QFR01	ASSY CASE-FRONT	GH98-06461A
QIF01	PMO COVER-IF	GH72-44663A
QKP01	ASSY KEYPAD-(XEF/SIL)	GH98-06460A
QLC01	LCD-MODULE SGHL170	GH07-01209A
QME03	KEY FPCB-SGHL170 TOUCH 34 KEY	GH59-05081A
QMO01	MOTOR DC-SCH-S269	GH31-00319A
QMP01	PBA MAIN-SGHL170	GH92-04055A
QMW01	ASSY COVER-MAIN WINDOW	GH98-06465A
QRE01	ASSY CASE-REAR_FTM	GH98-07501A
QRF01	TAPE-RF SHEET	GH74-35355A
QSP01	ASSY ETC-SGHL170 SPK INT ASS'Y	GH59-05124A
QVO01	PMO KEY-VOL	GH72-44664A
QVO08	ASSY DECO-SIDE BELT	GH98-06464A

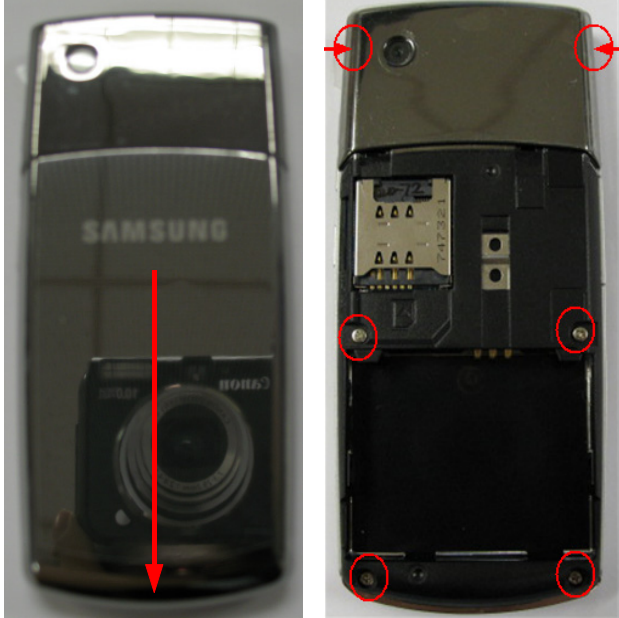
# 7. Disassembly and Assembly Instructions

## 7-1. Disassembly

<p><b>1</b></p> 	<p><b>2</b></p>  <p>1) Disassemble REAR case with being careful of the LOCKER position. 2) Open the REAR case from the FRONT. 3) Disassemble LCD/KEY FPCB from two connectors of PBA.</p>
<p>1) Remove the BATTERY COVER. 2) Remove the SCREWS. (6 points)</p>	
<p><b>3</b></p> 	<p><b>4</b></p>  <p>Side belt</p> <p>1) Disassemble the CAMERA from PBA assy. 2) Disassemble the Side belt from FRONT.</p>
<p>1) Disassemble the PBA Assy from FRONT. (Be careful of crack antenna soldering pad)</p>	

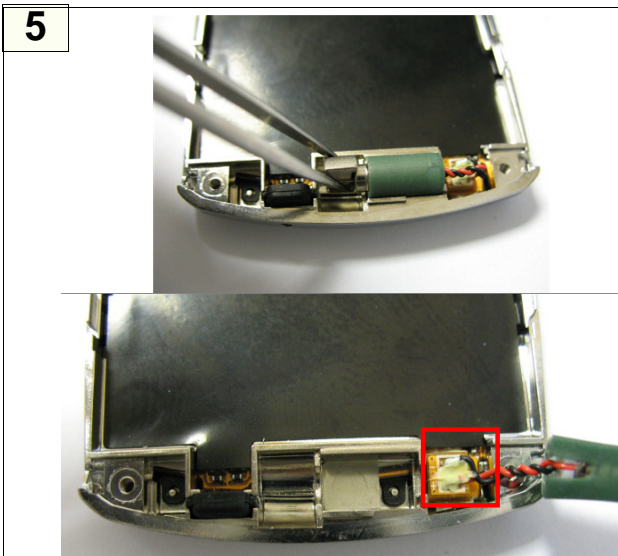

1) Disassemble the MOTOR from the FRONT.

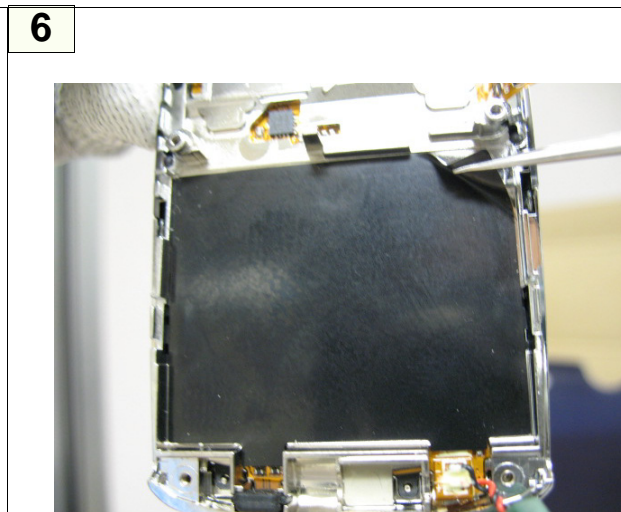

1) Remove The Black film from FRONT.

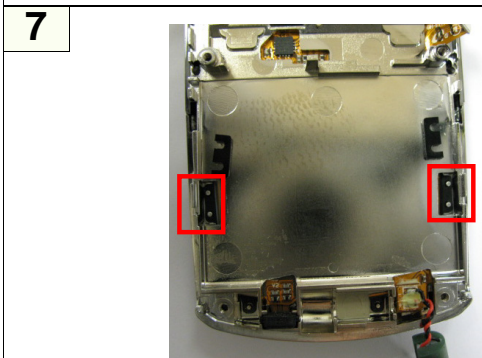

1) Remove rubbers in 2 flange position.

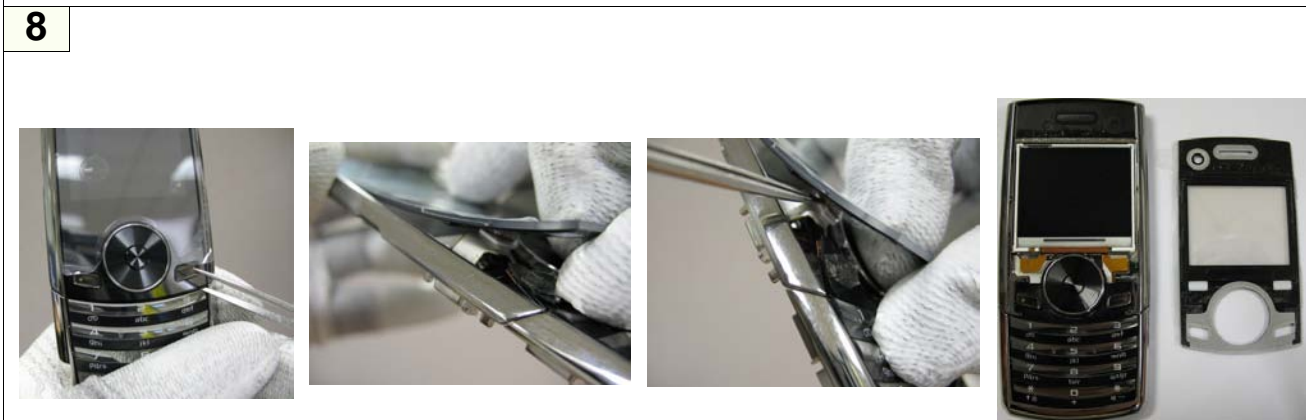

1) Open the Main window from bottom position to the top.

※ **Caution**

- Be careful not to make a scratch on Main window.
- Be careful not to damage on Main window.
- Be careful not to damage on Touch key sensor in KEY FPCB.



9

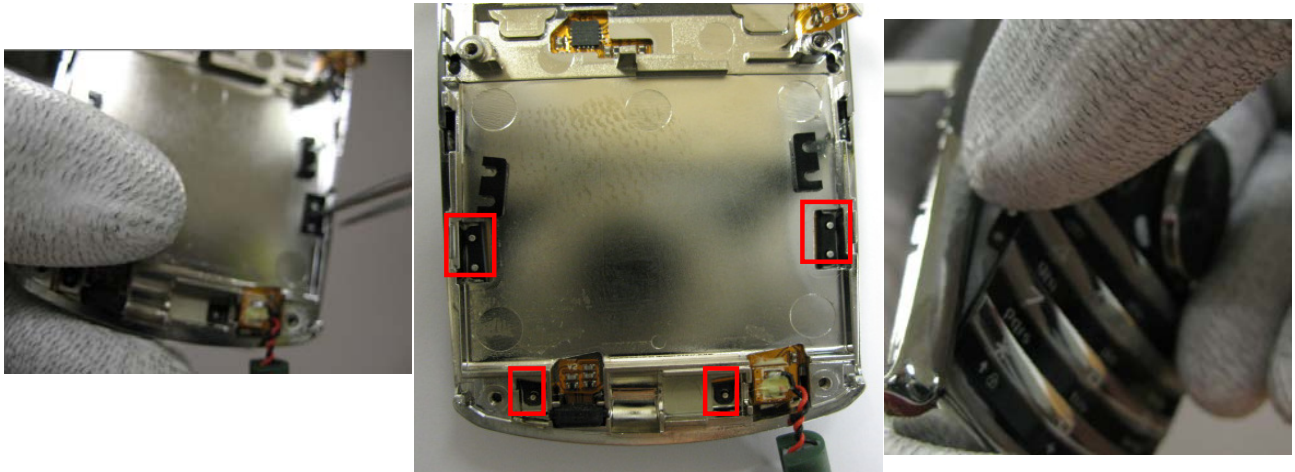

- 1) Pick out 4 flanges from FRONT.
- 2) Detach KEYPAD from FRONT.

10



- 1) Disassemble LCD from FRONT by using LCD disassembly hole.

## 7-2. Assembly

1



- 1) Assemble LCD with FRONT from bottom side.
- 2) Assemble KEY PBA with FRONT by inserting MIC portion at first.
- 3) Arrange MIC part into FRONT by pushing slightly. (Do not push with strong force)

2



- 1) Assemble KEYPAD with FRONT by inserting flanges of bottom side at first.
- 2) Set up flanges(4 points) into FRONT back side.

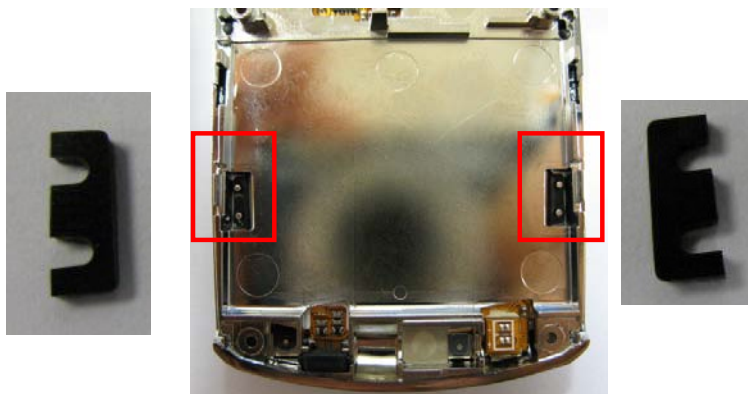

- 1) Insert rubbers. (2 points)  
(Protection for separation KEYPAD from FRONT)

3



1) Attach MAIN WINDOW into FRONT from TOP side to BOTTOM side.

4

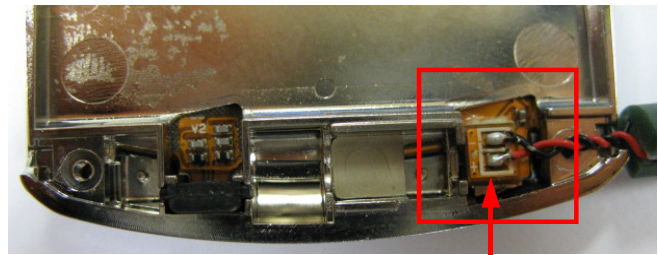

(+)

1) Solder MOTOR wire.  
(Red line(+) must be located at bottom side.)

5

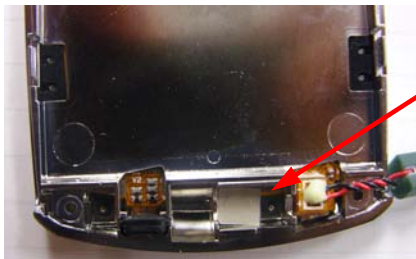

Check up flange joint status

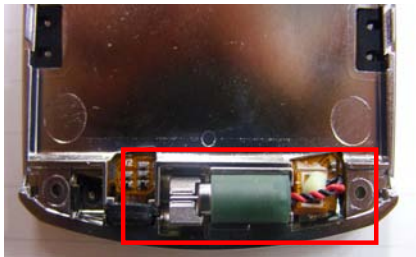

Push a MOTOR wire lightly

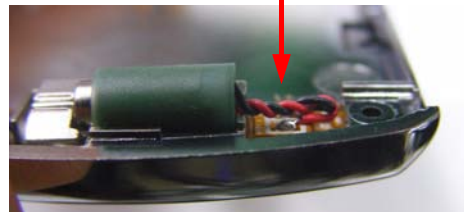

1) Check up flange joint status.  
2) Insert MOTOR on FRONT.  
3) Arrange MOTOR wire by pushing a wire lightly.



6



- 1) Attach black tape on FRONT.
- 2) Assemble SIDE BELT with FRONT.

7



- 1) Assemble LCD FPCB with PBA Assy. (Arrange silk line between LCD FPCB and PBA)
- 2) Set up Hook in bottom side and Assemble PBA Assy with FRONT.
- 3) Assemble KEY FPCB with PBA Assy.
- 4) Assemble CAMERA with PBA Assy.

8

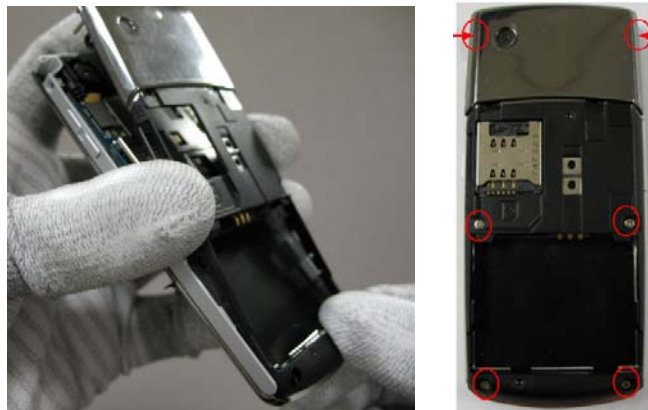

- 1) Assemble REAR case with FRONT Assy from bottom side to top side.
- 2) Assemble screws. (6points)

---

# 10. Flow Chart of Troubleshooting

---

## 10-1. Baseband

### 10-1-1. Power ON

① Flow chart of Power ON

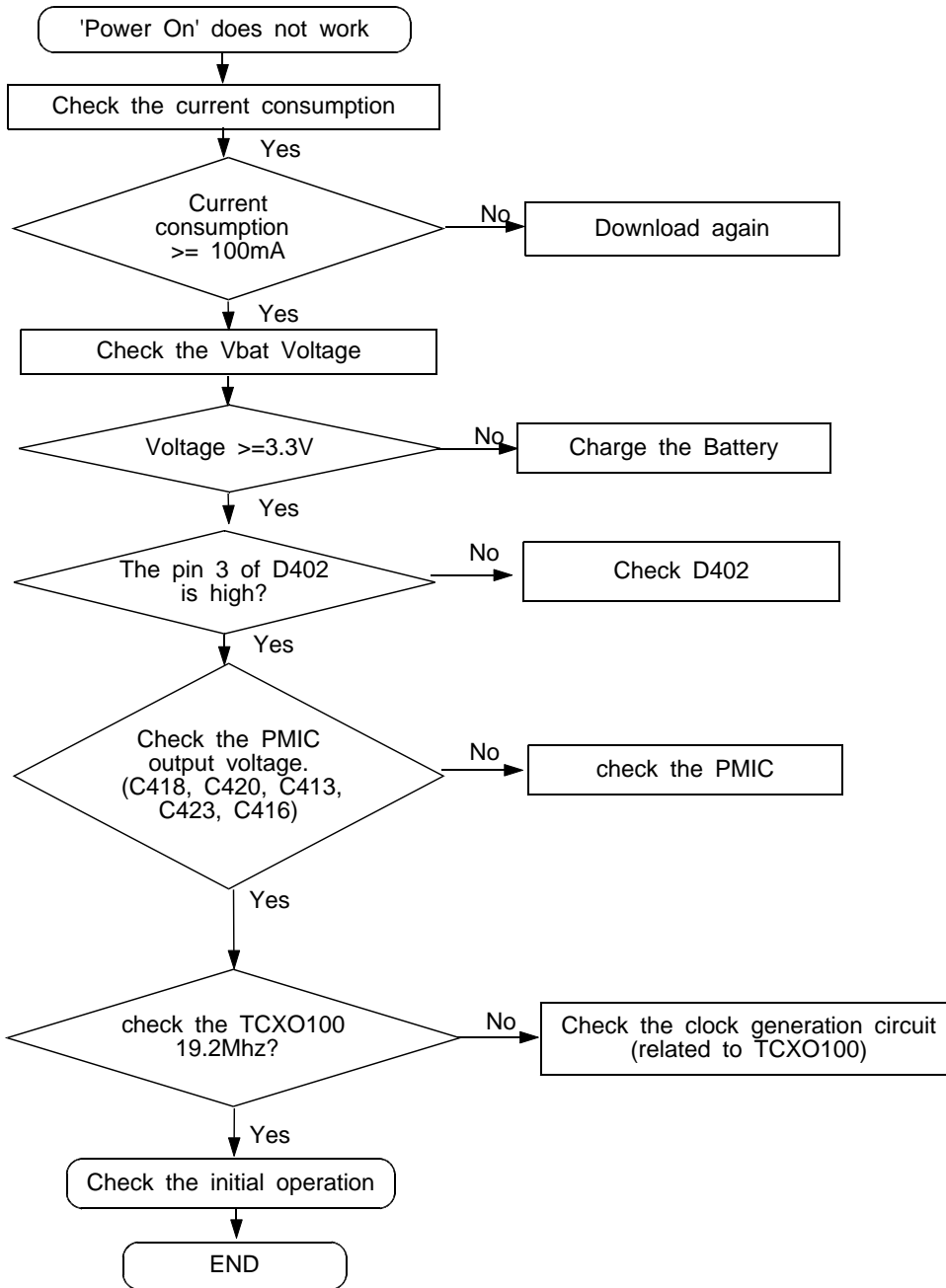

② Schematic for Power ON

PM IC

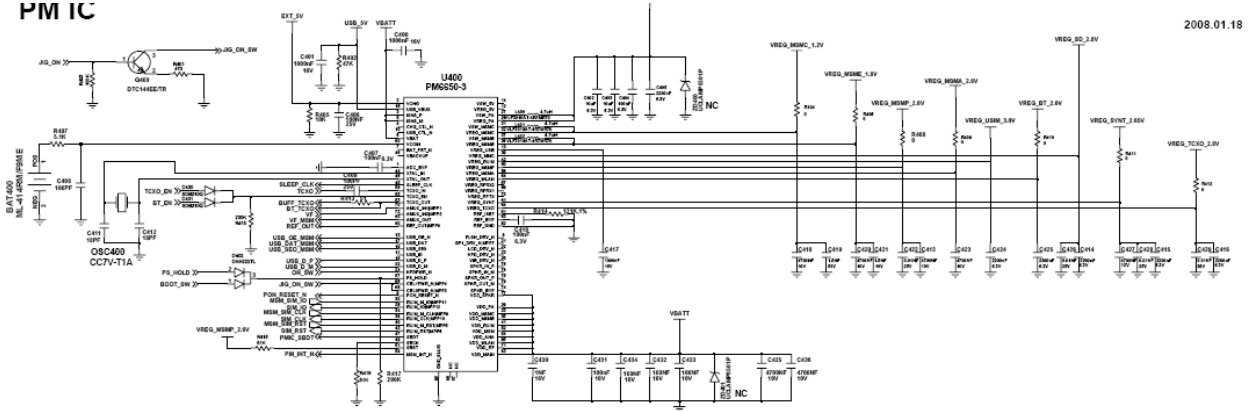

③ Layout for Power ON

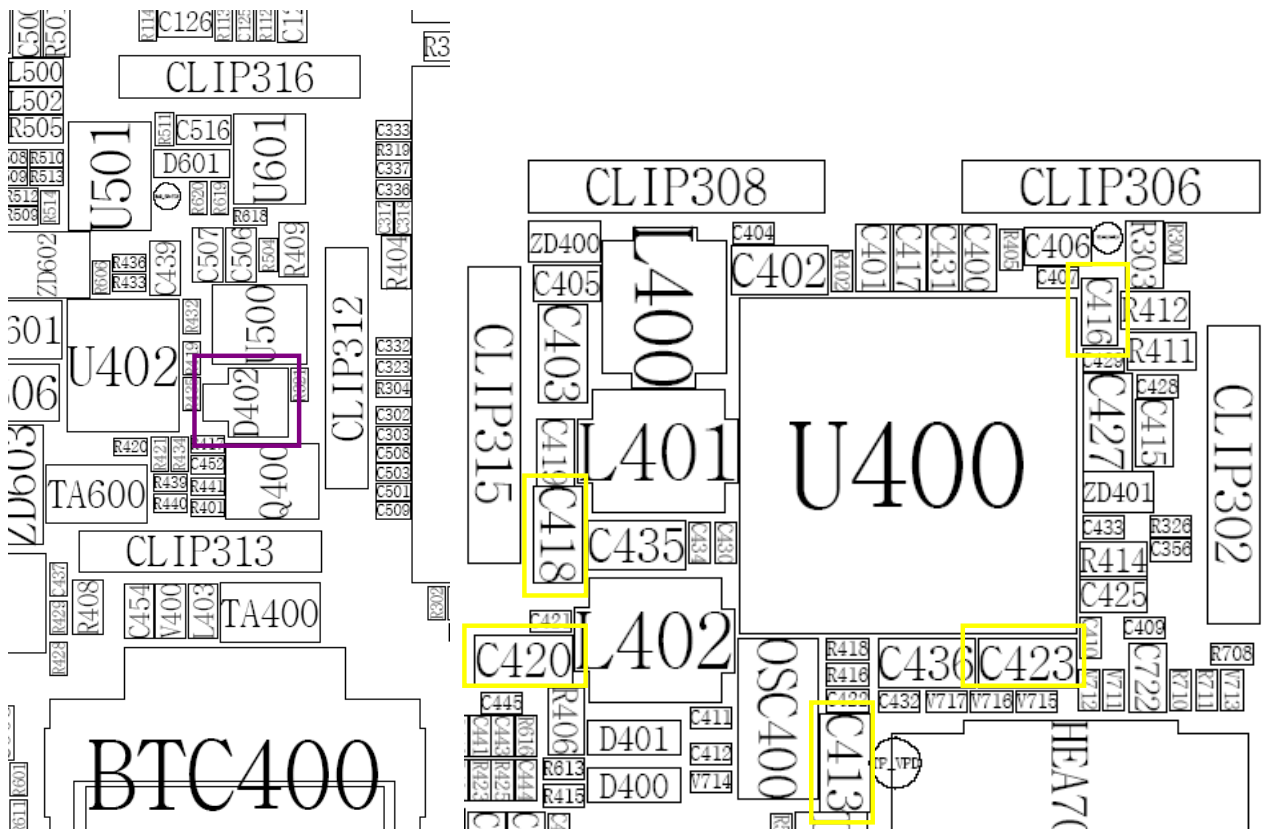

## 10-1-2. System Initial

① Flow chart of System Initial

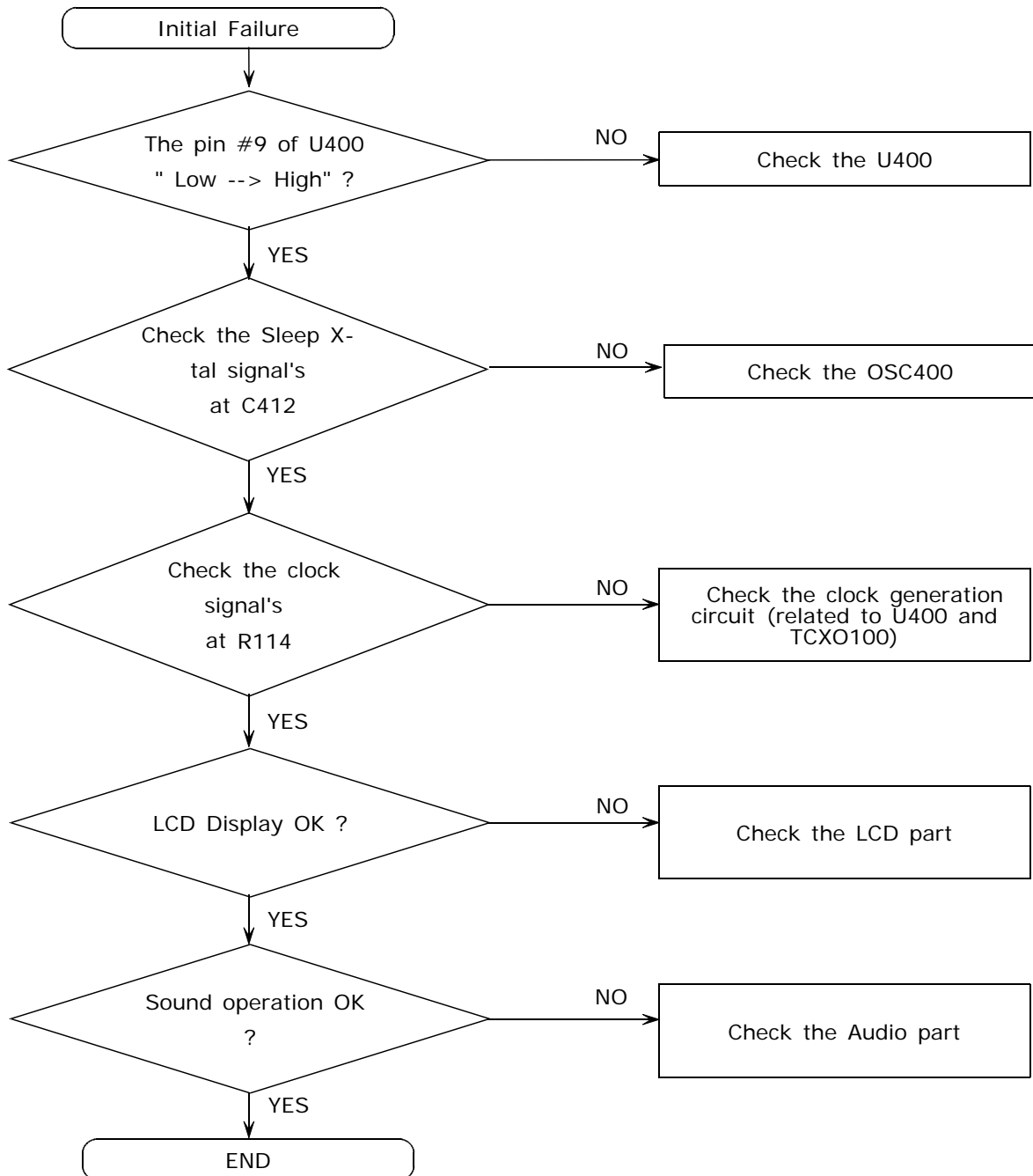

② Schematic for System Initial

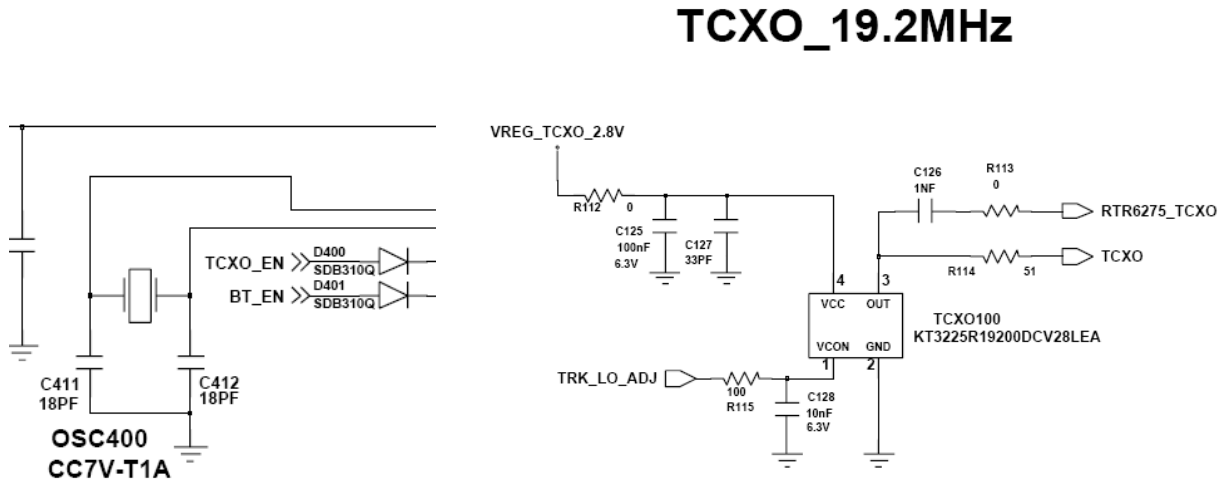

③ Layout for System Initial

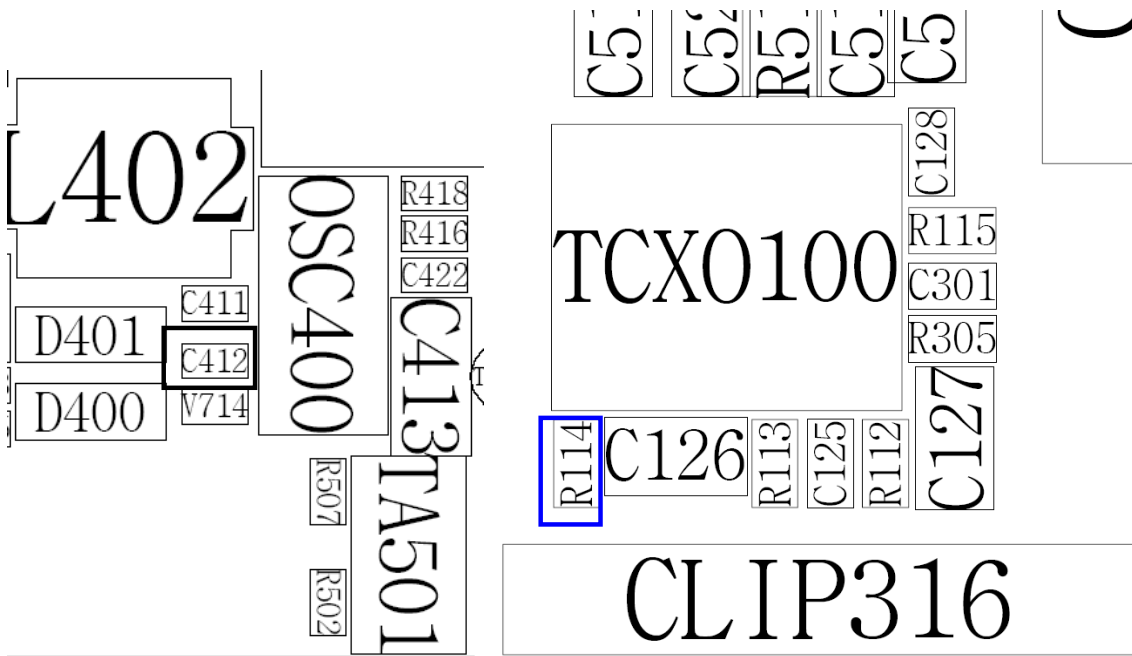



**10-1-3. SIM Part**

① Flow chart of SIM Part

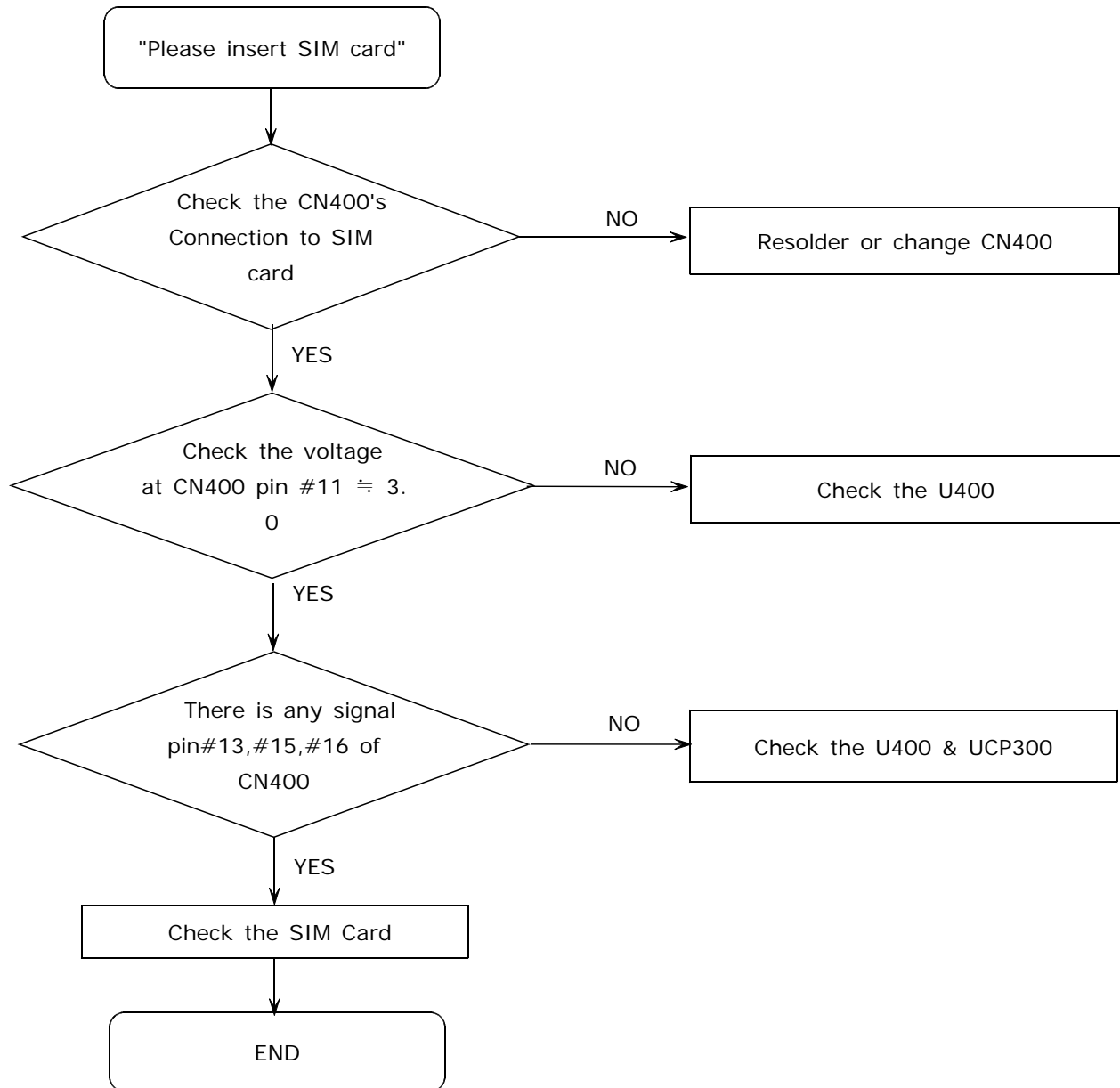

\*\* Check SIM's signal  
when you see SIM checking display

② Schematic for SIM Part

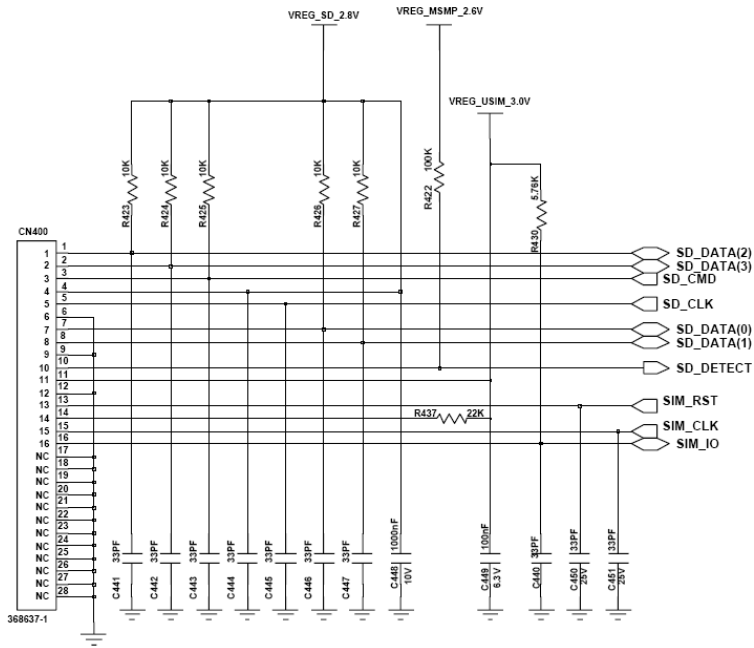

③ Layout for SIM Part

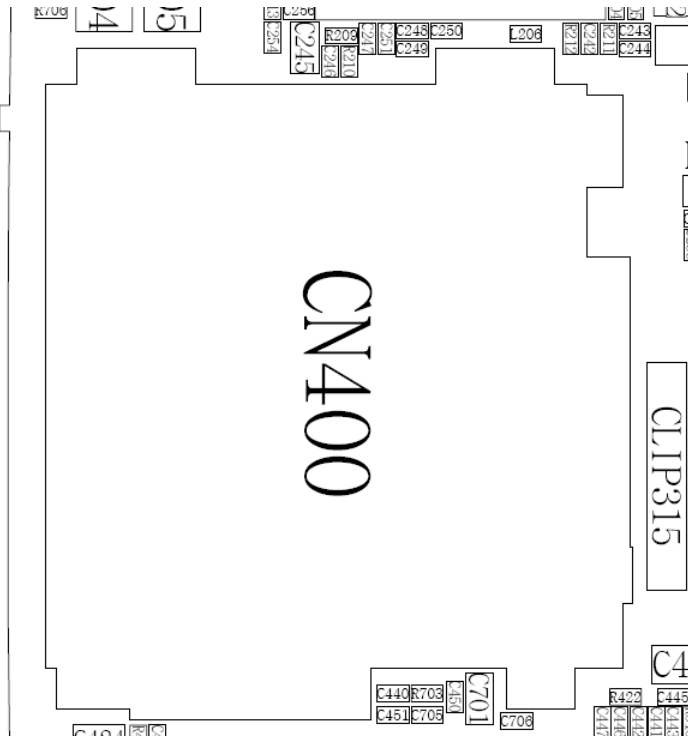

## 10-1-4. Charging Part

① Flow chart of Charging part

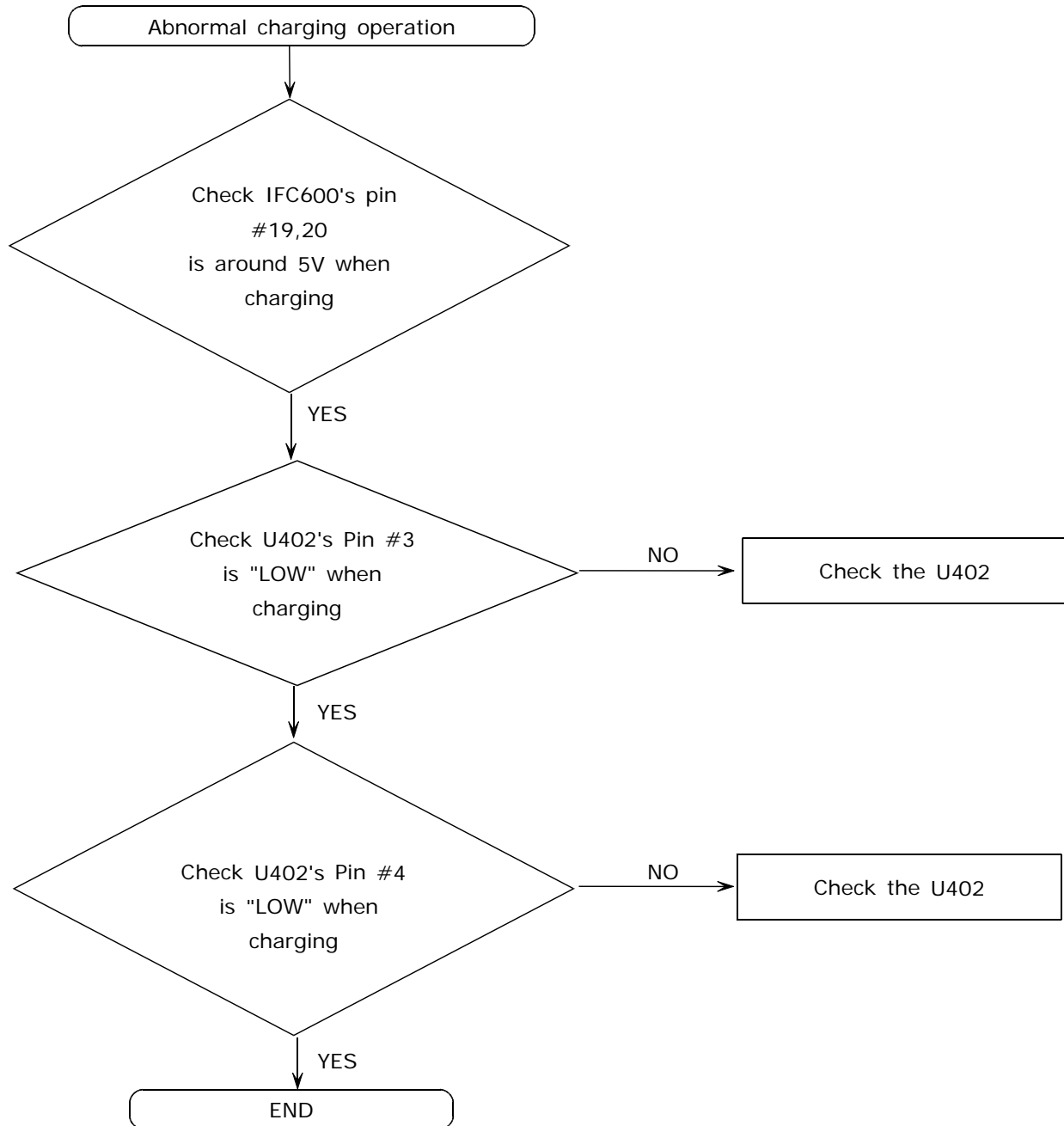

② Schematic for Charging part

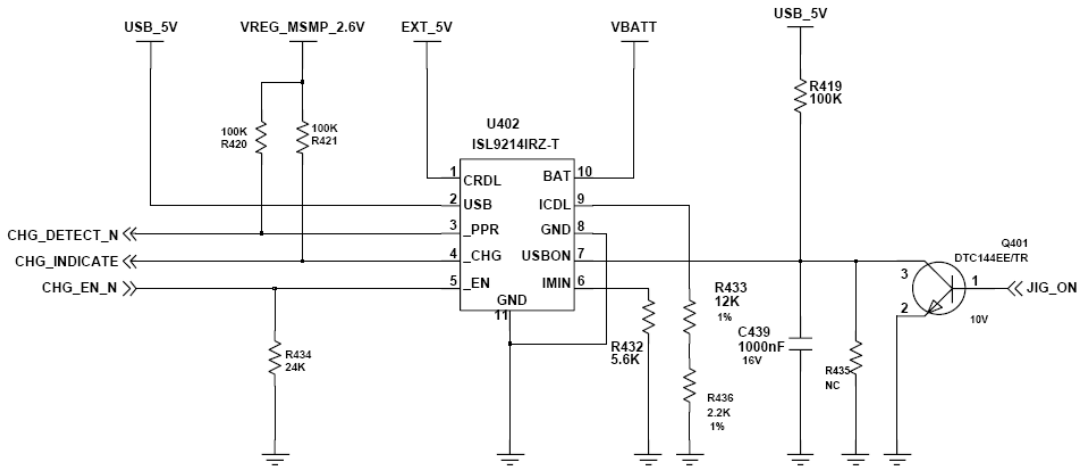

③ Layout for Charging part

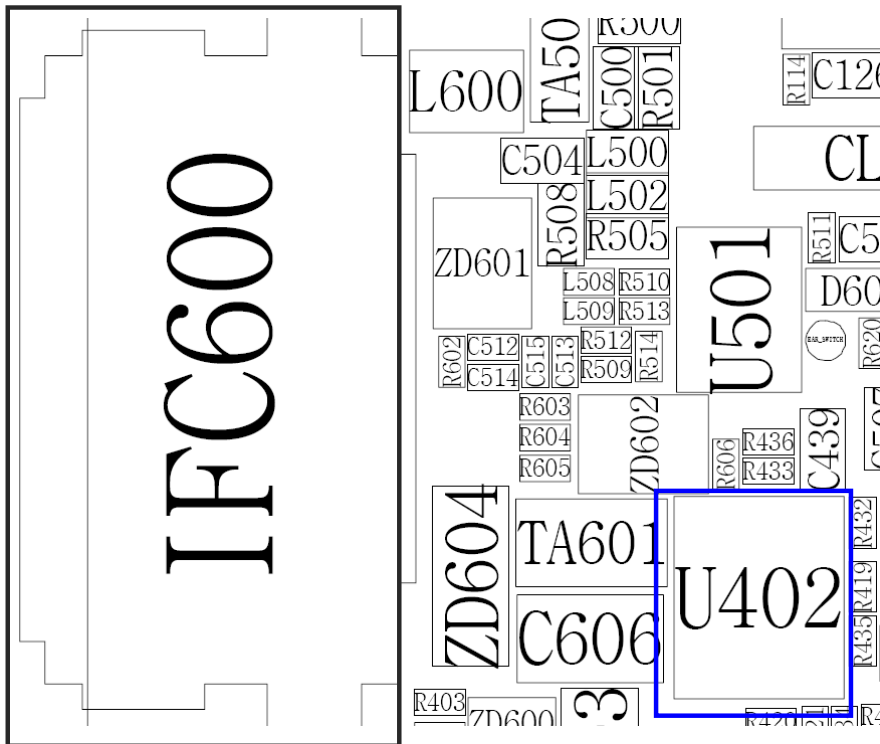

## 10-1-5. Microphone Part

### ① Flow chart of Microphone Part

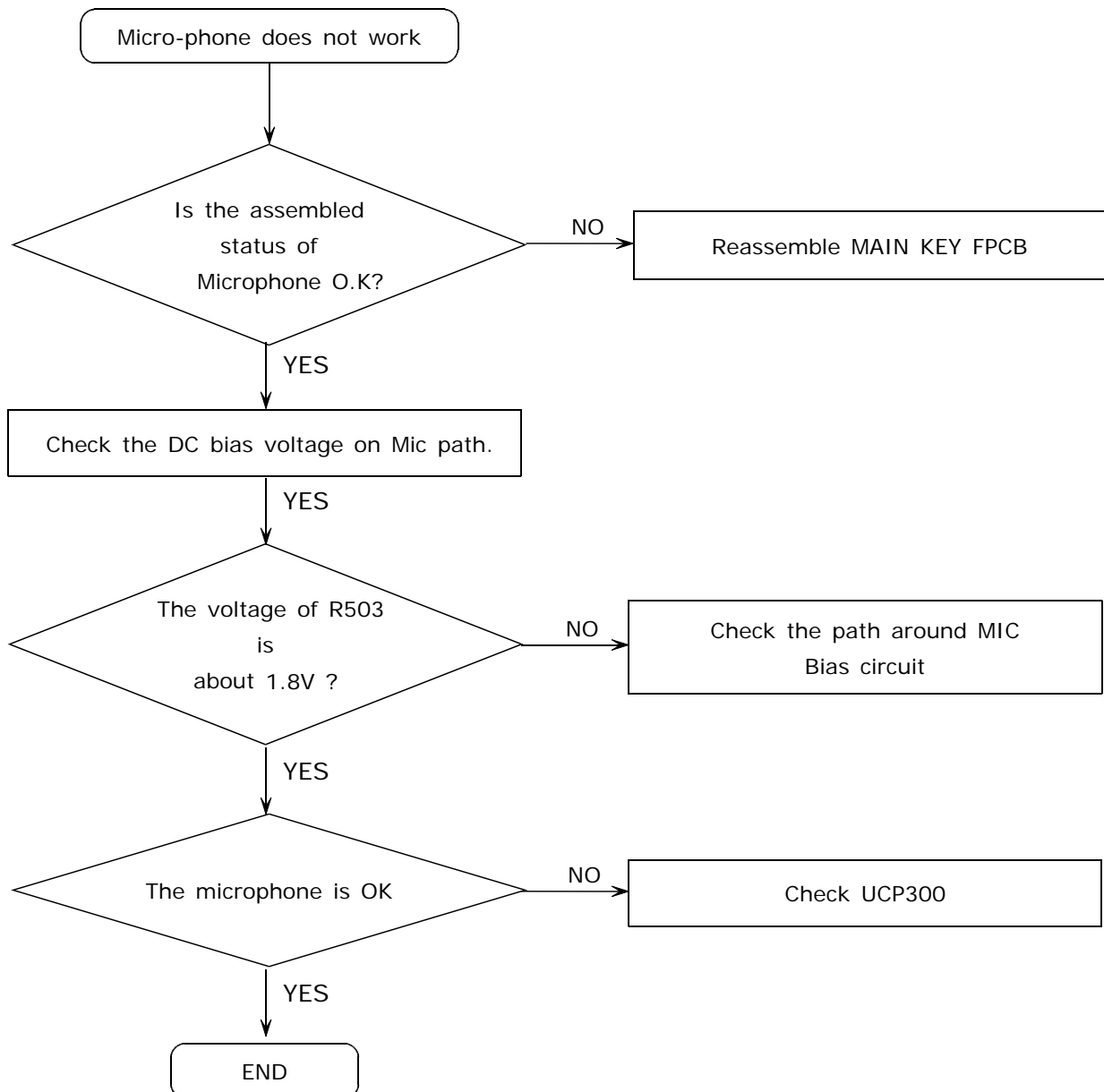

② Schematic for Microphone Part

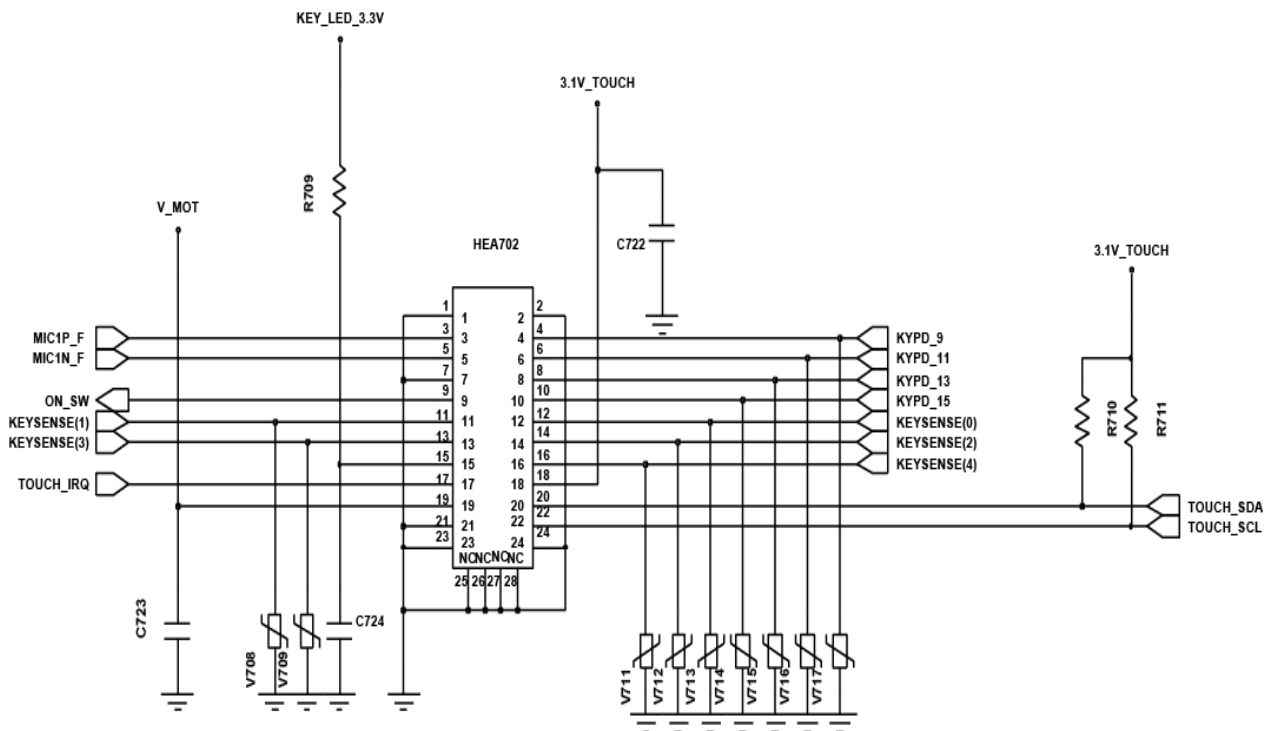
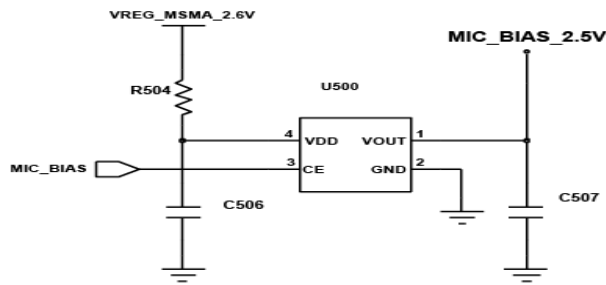
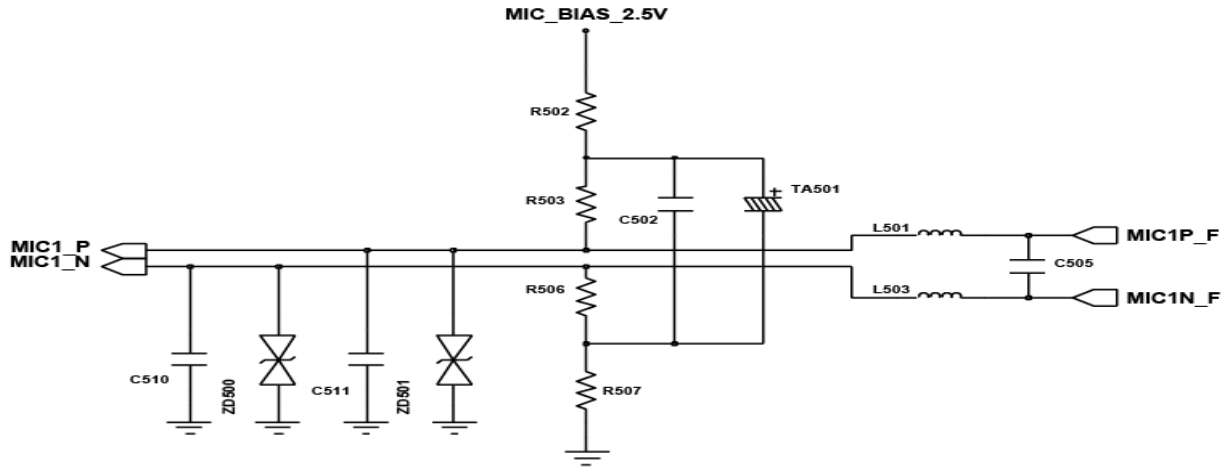

③Layout for Microphone Part

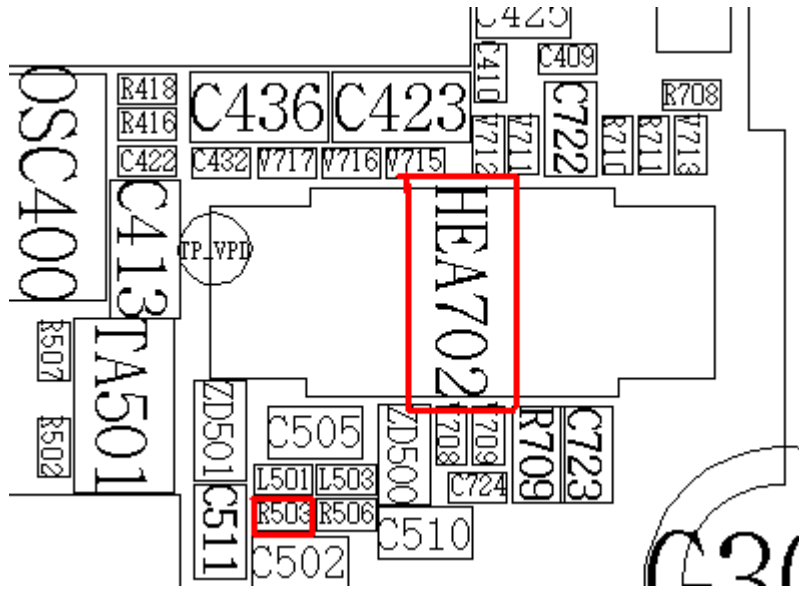

# UCP300 MSM6245

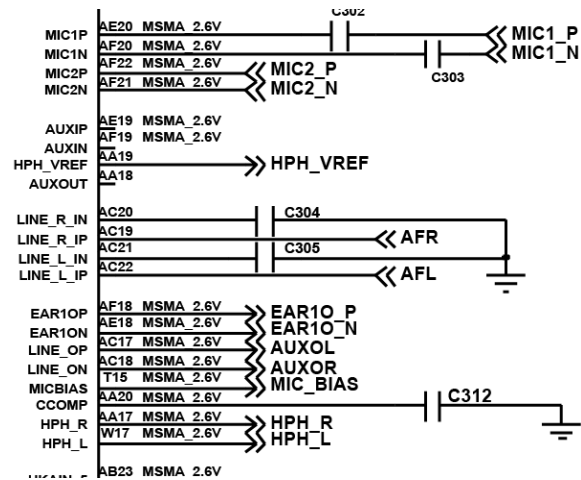

## 10-1-6. Speaker Part

### ① Flow chart of Speaker Part

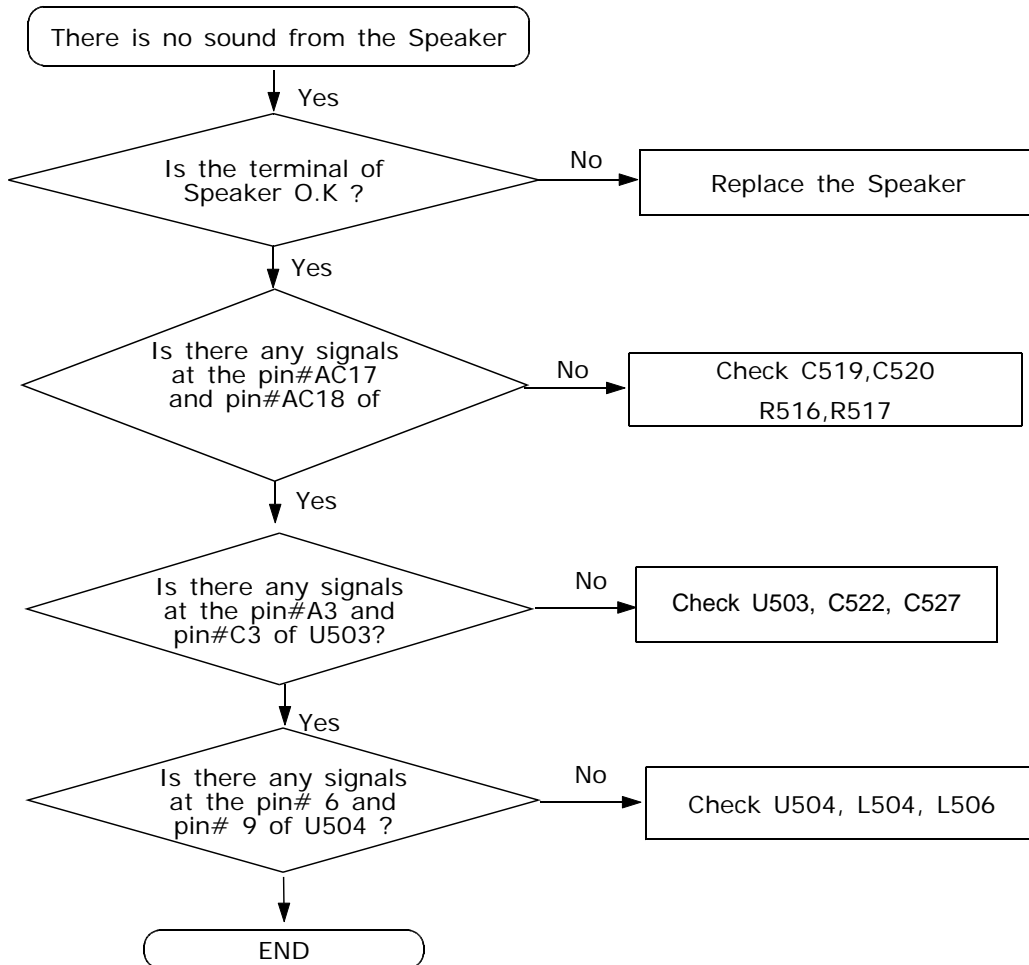



### 10-1-7. Receiver Part

① Flow chart of Receiver Part

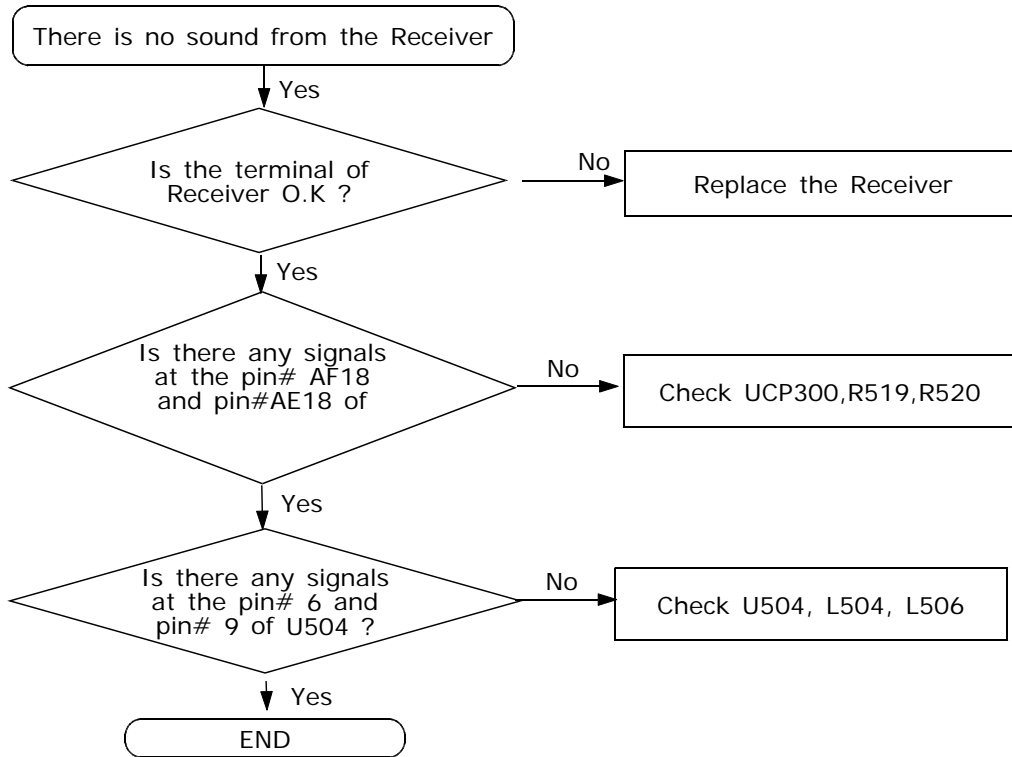

② Schematic for Receiver & Speak Part

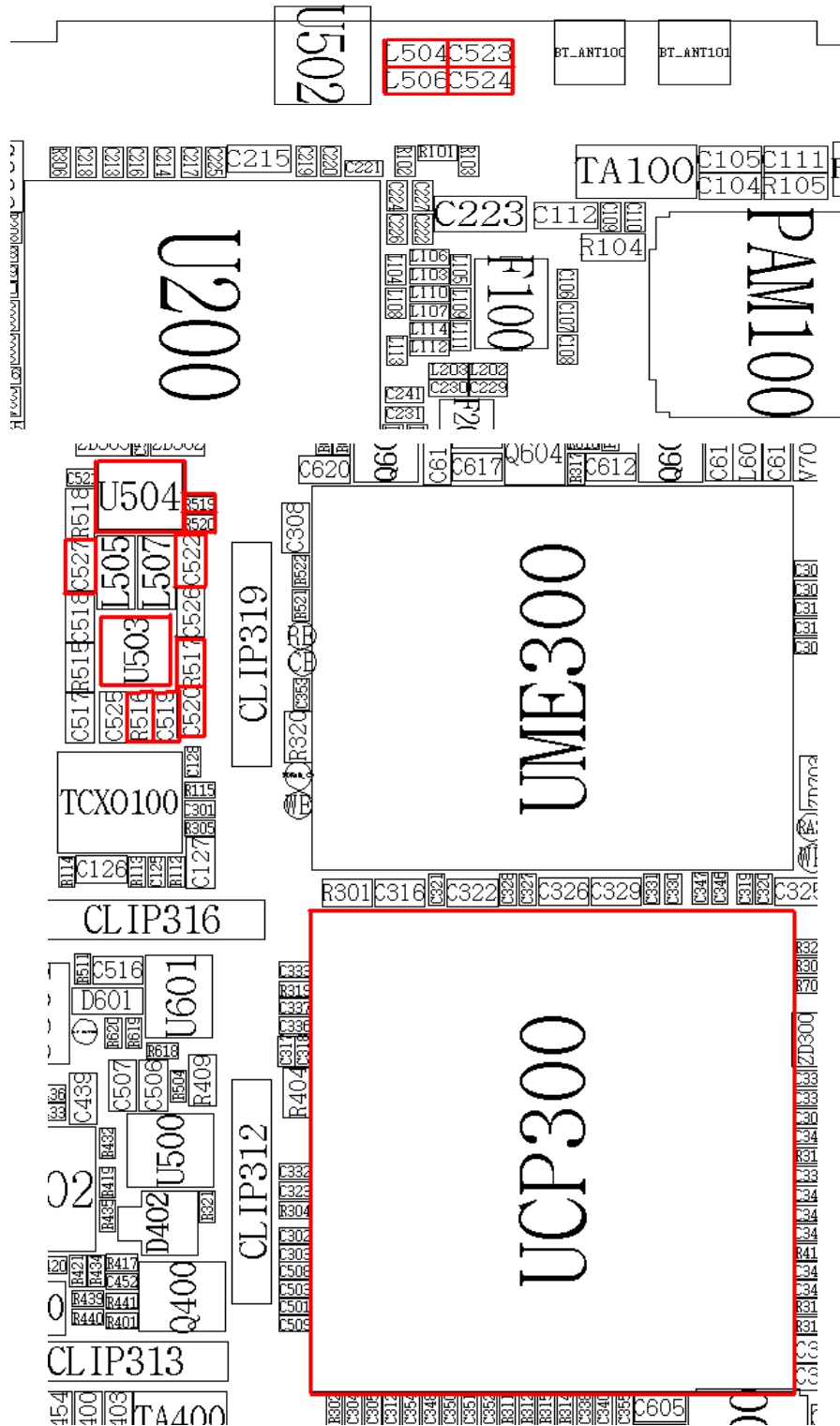

③ Layout for Headset Part

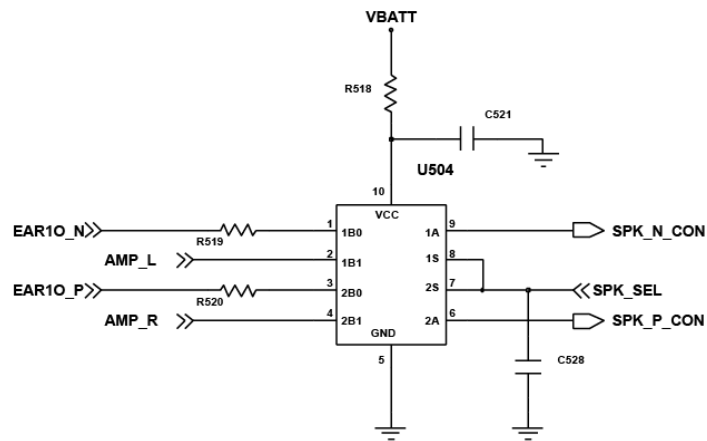
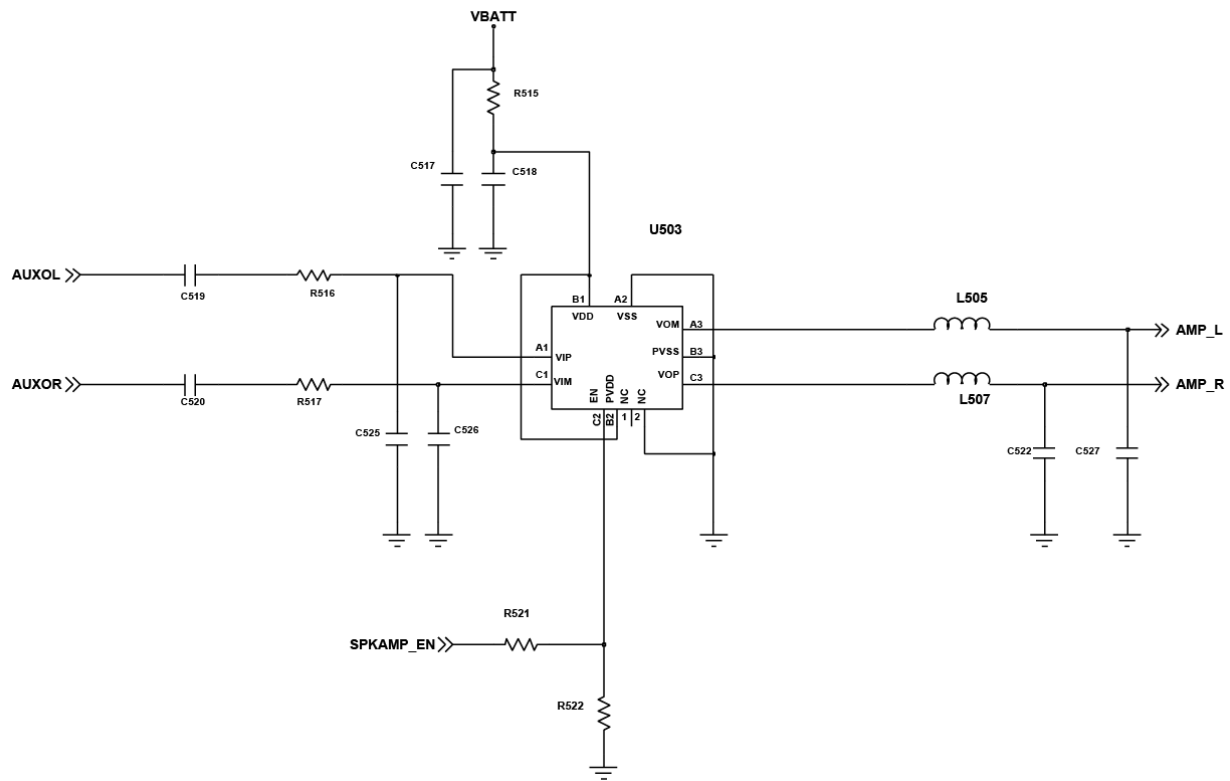

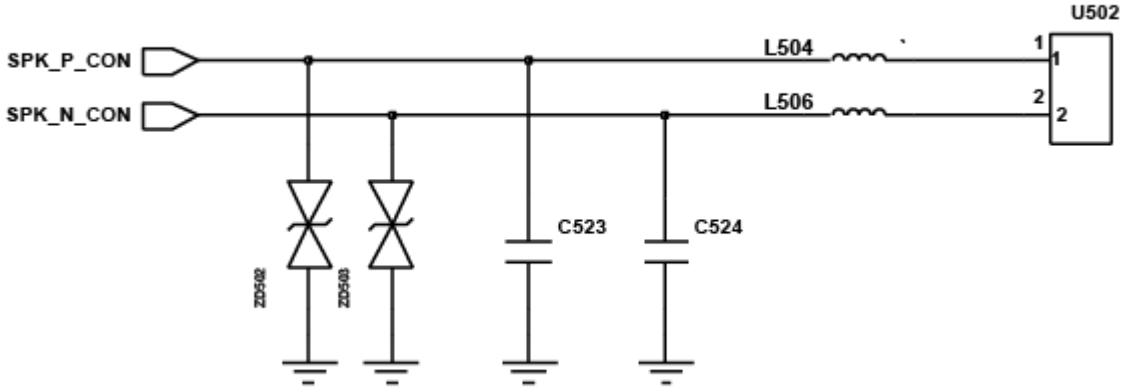

# UCP300 MSM6245

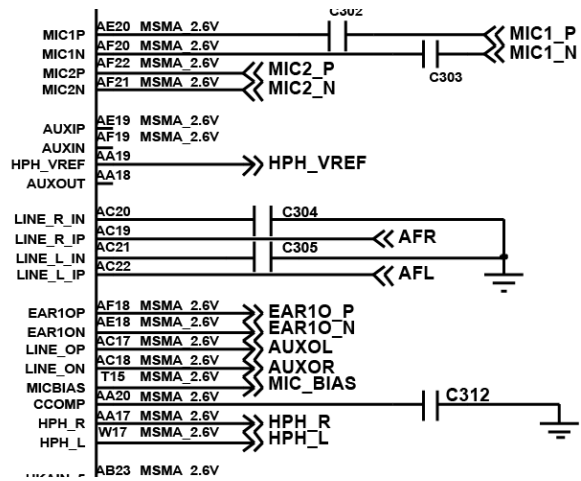

### 10-1-8. Headset Part

① Flow chart of Headset Part

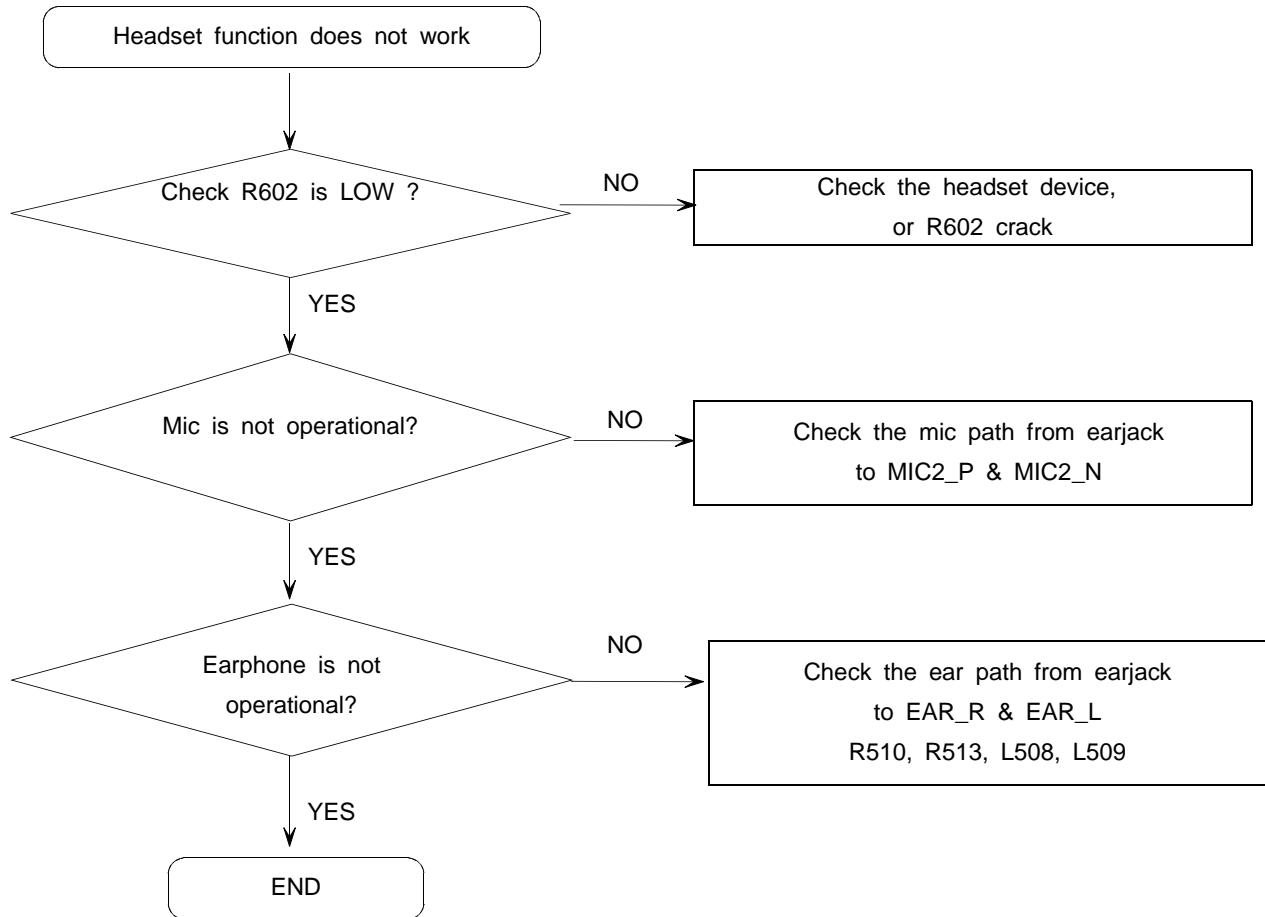

② Schematic for Headset Part

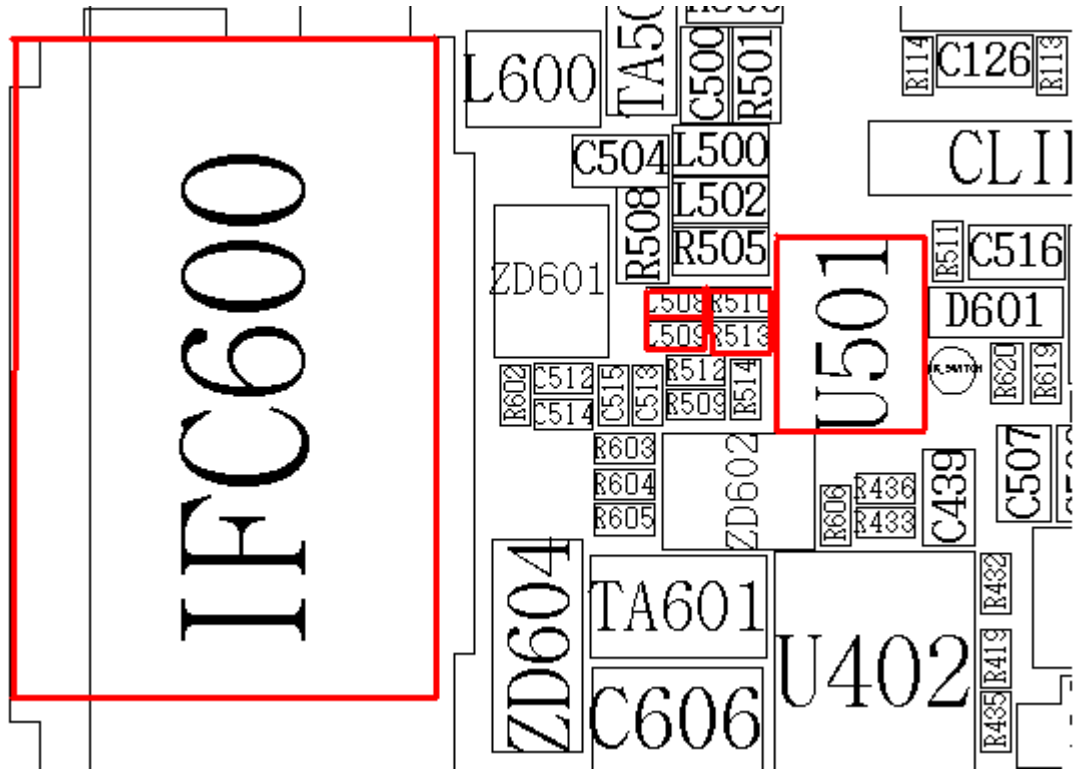

③ Layout for Headset Part

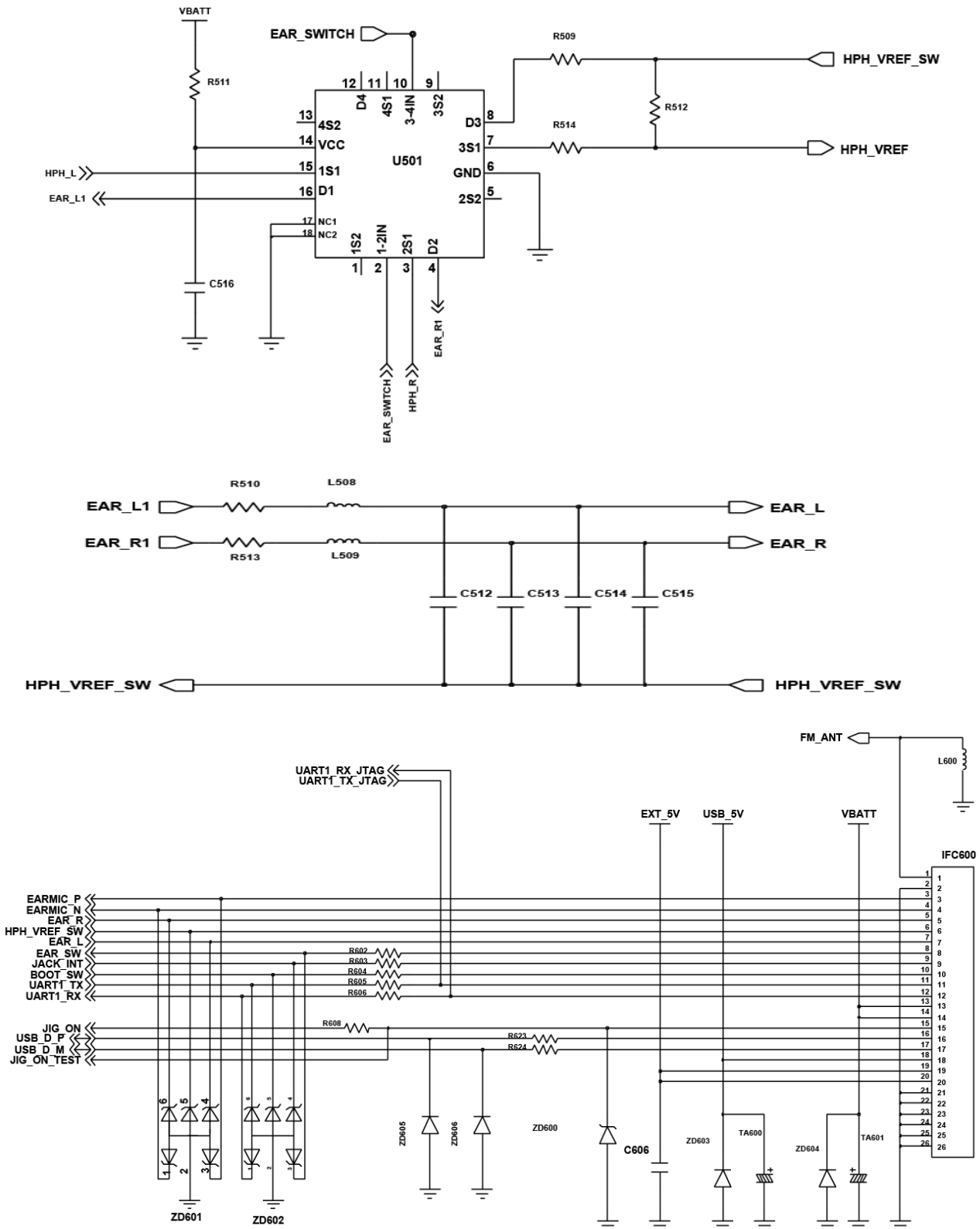

### 10-1-9. Camera Part (Mega and QCIF)

① Flow chart of Camera Part (Mega and QCIF)

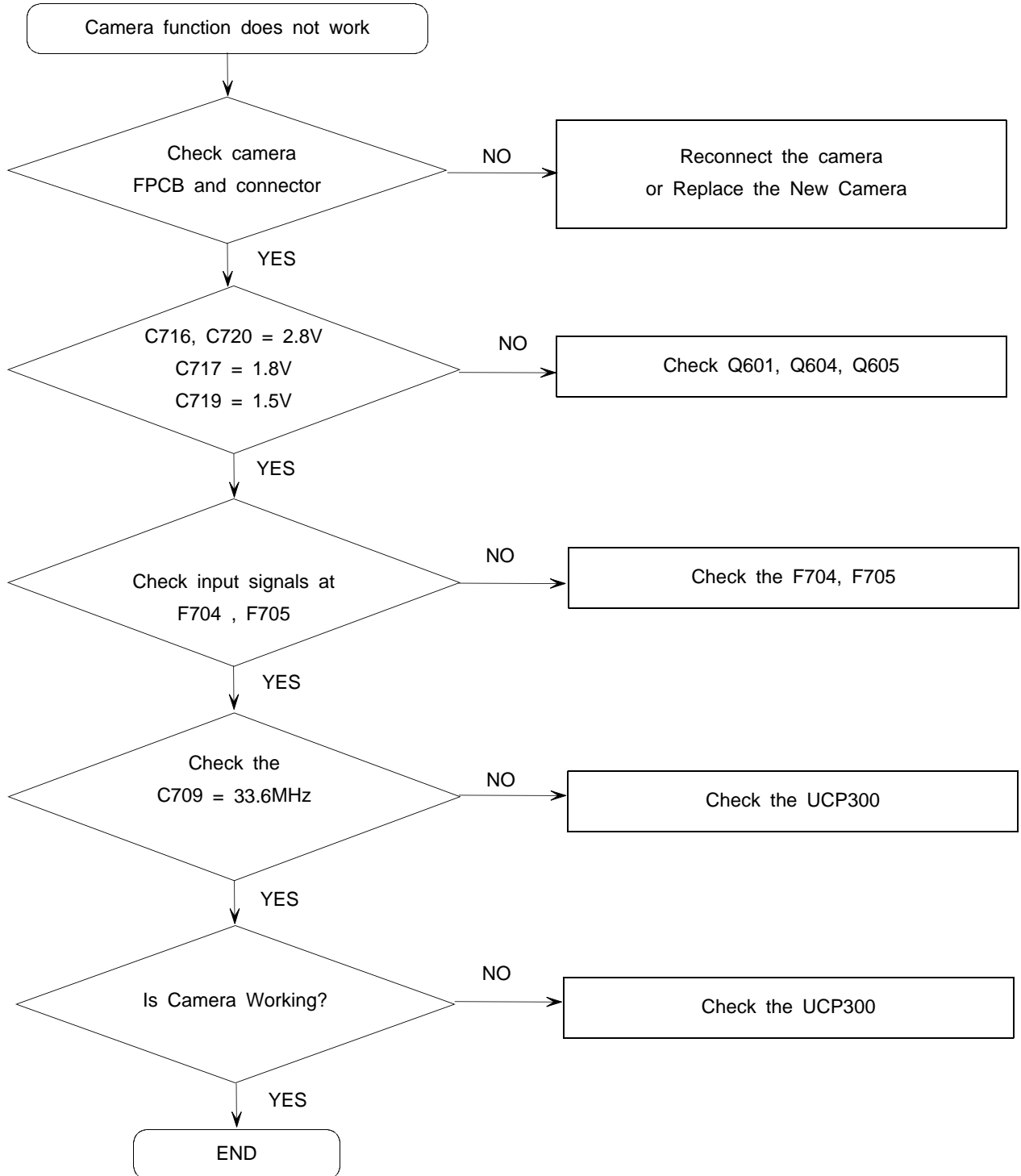



② Schematic for Camera Part (Mega and QCIF)

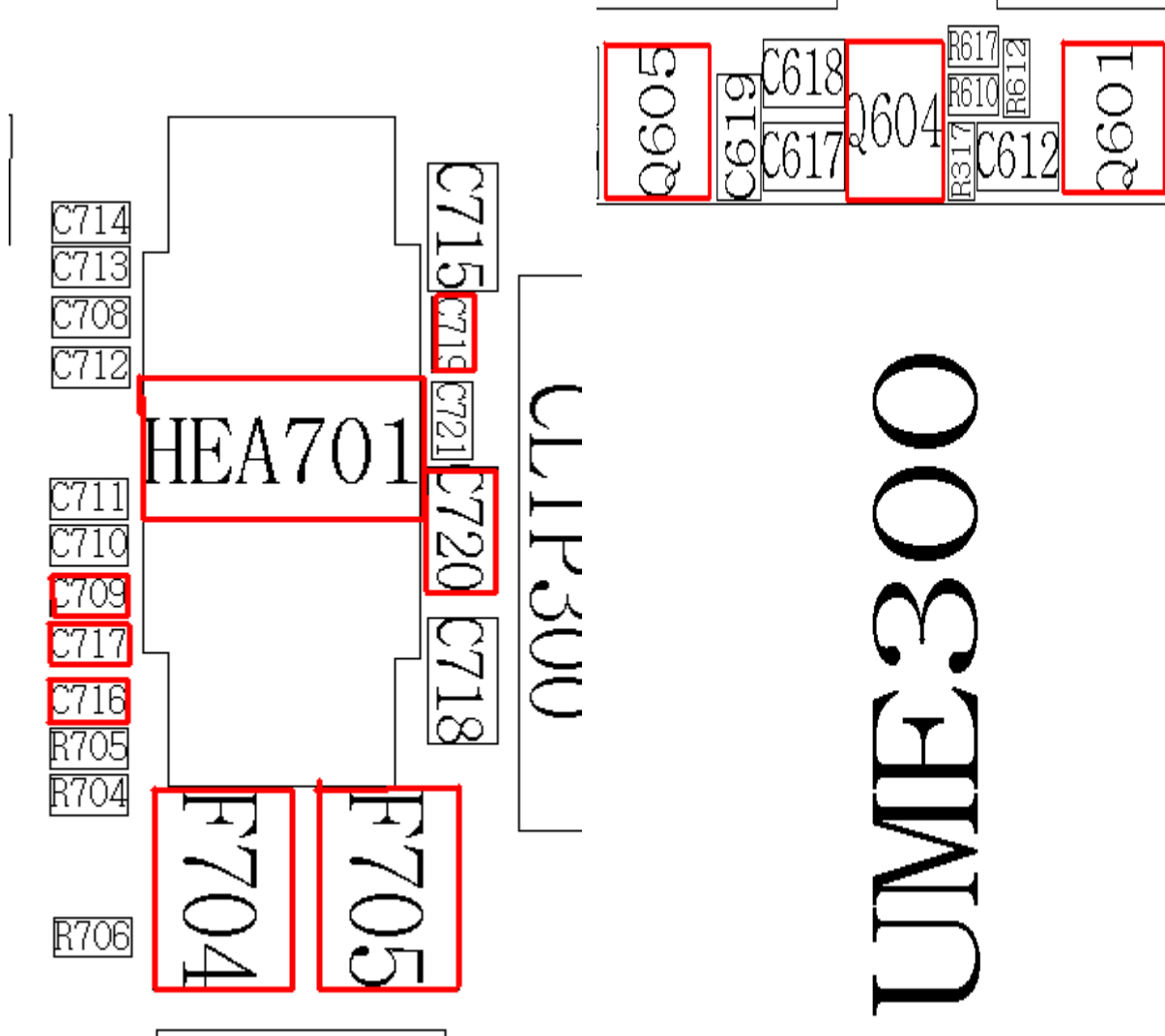

③ Layout for Camera Part (Mega and QCIF)

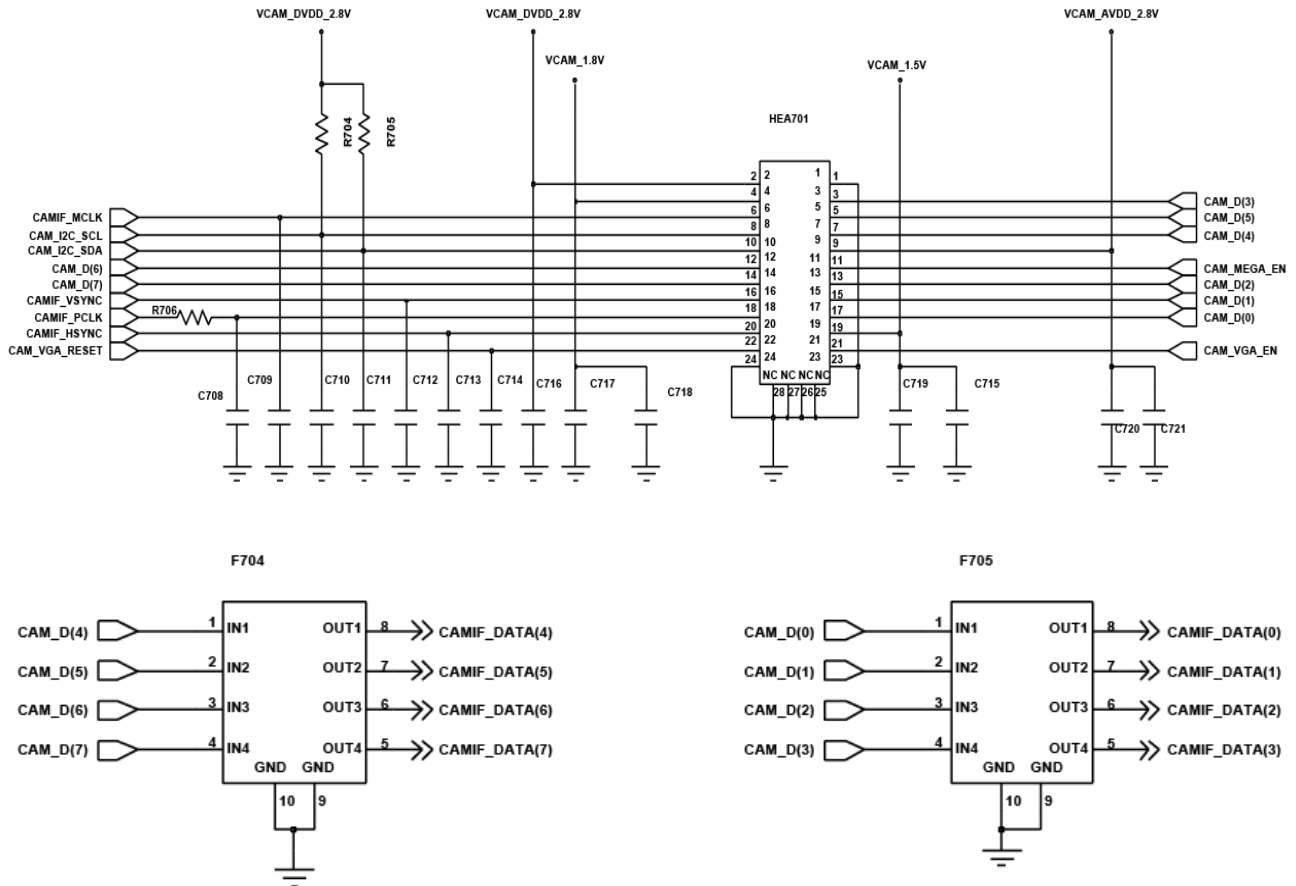

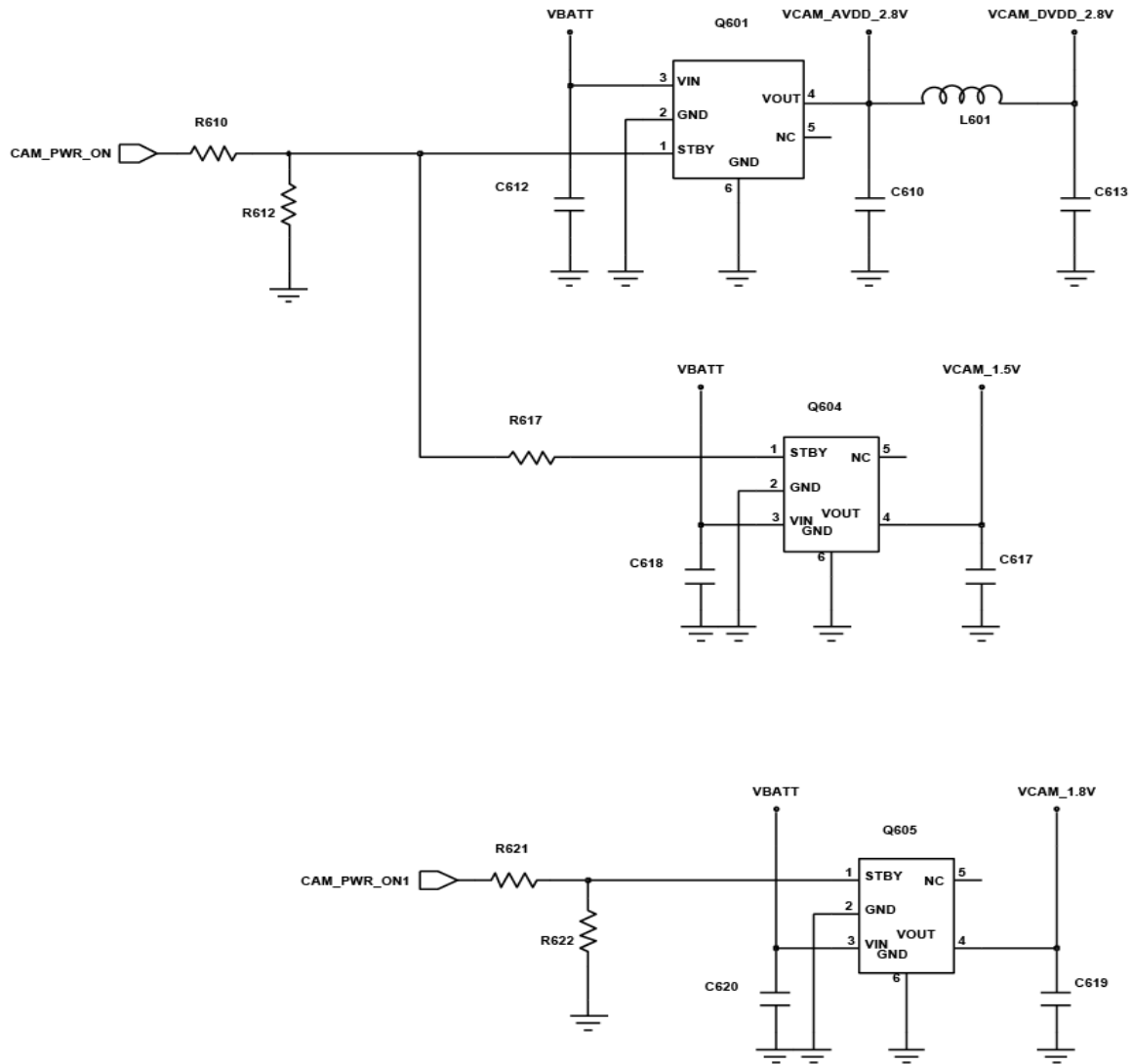

**10-2.RF**  
**10-2-1. EGSM900 Receiver**

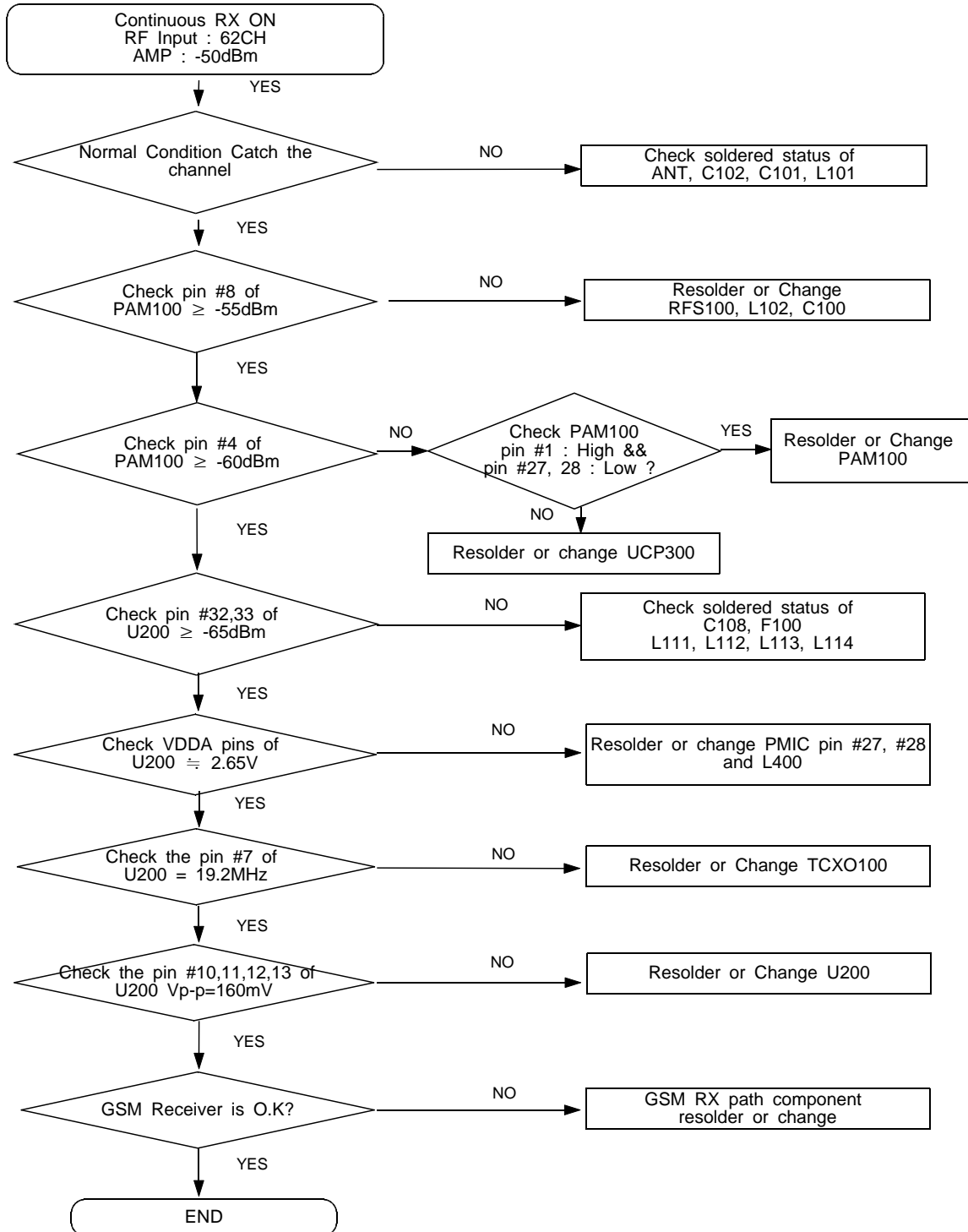

### 10-2-2. EGSM900 Transmitter

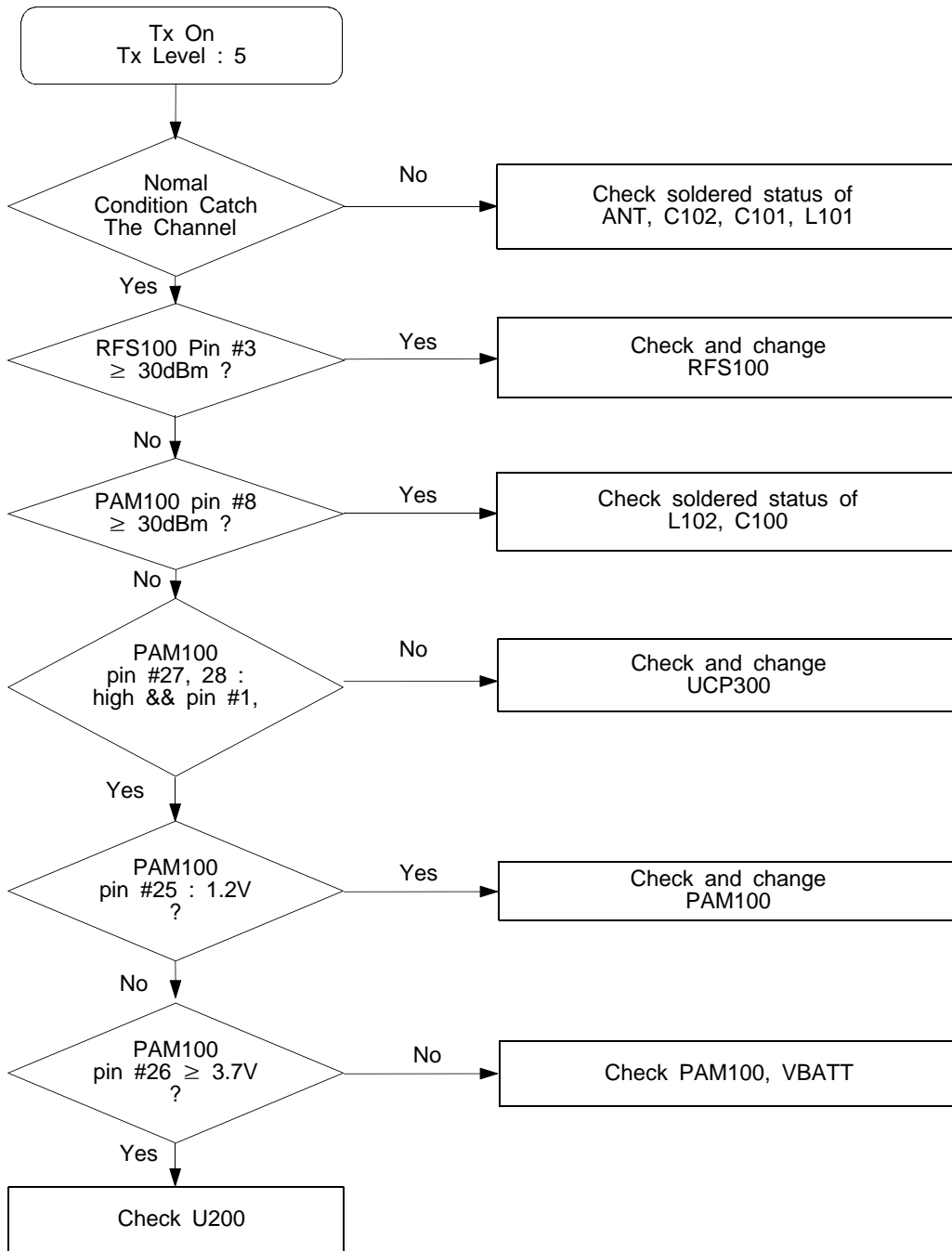

10-2-3. DCS1800 Receiver

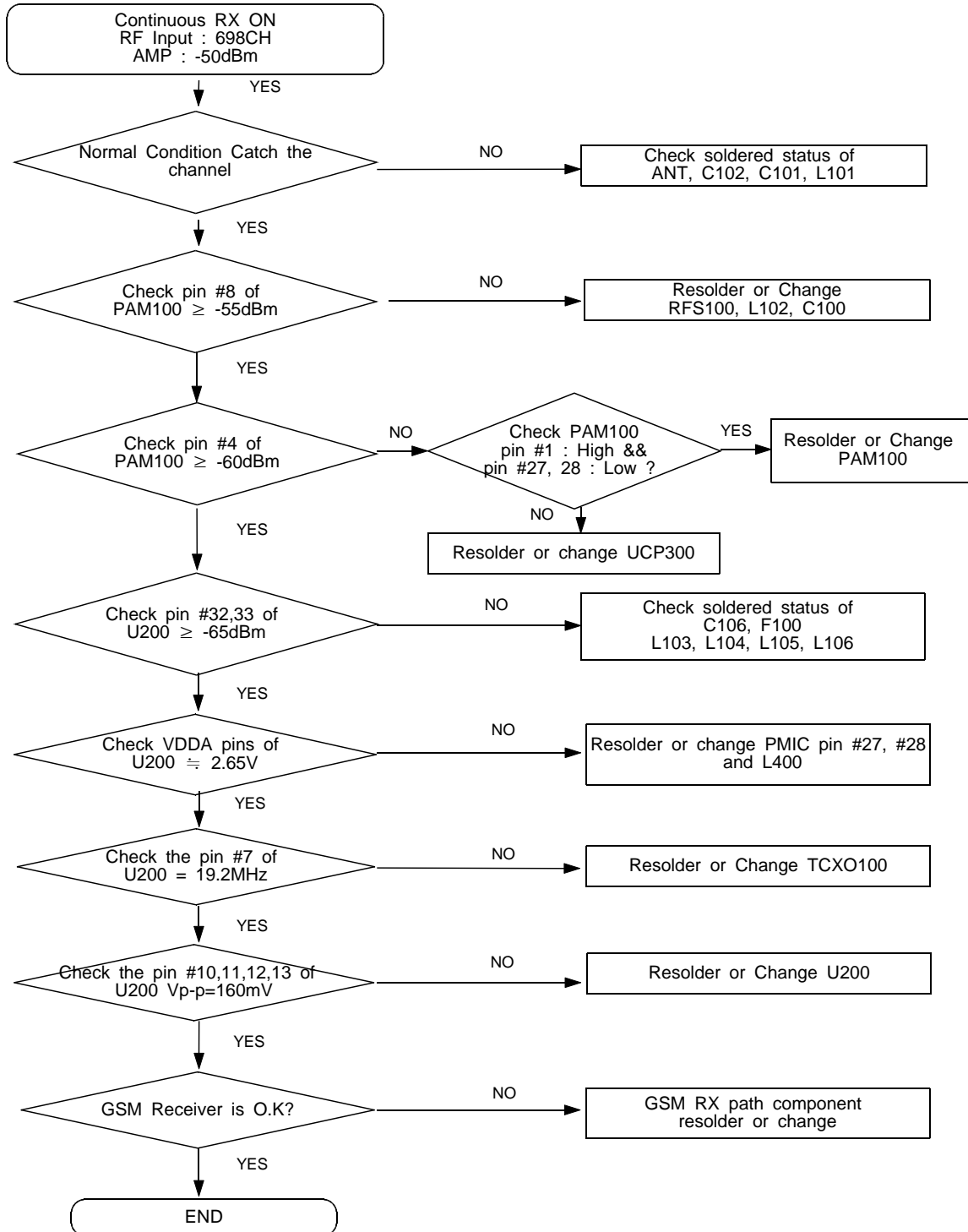

### 10-2-4. DCS1800 Transmitter

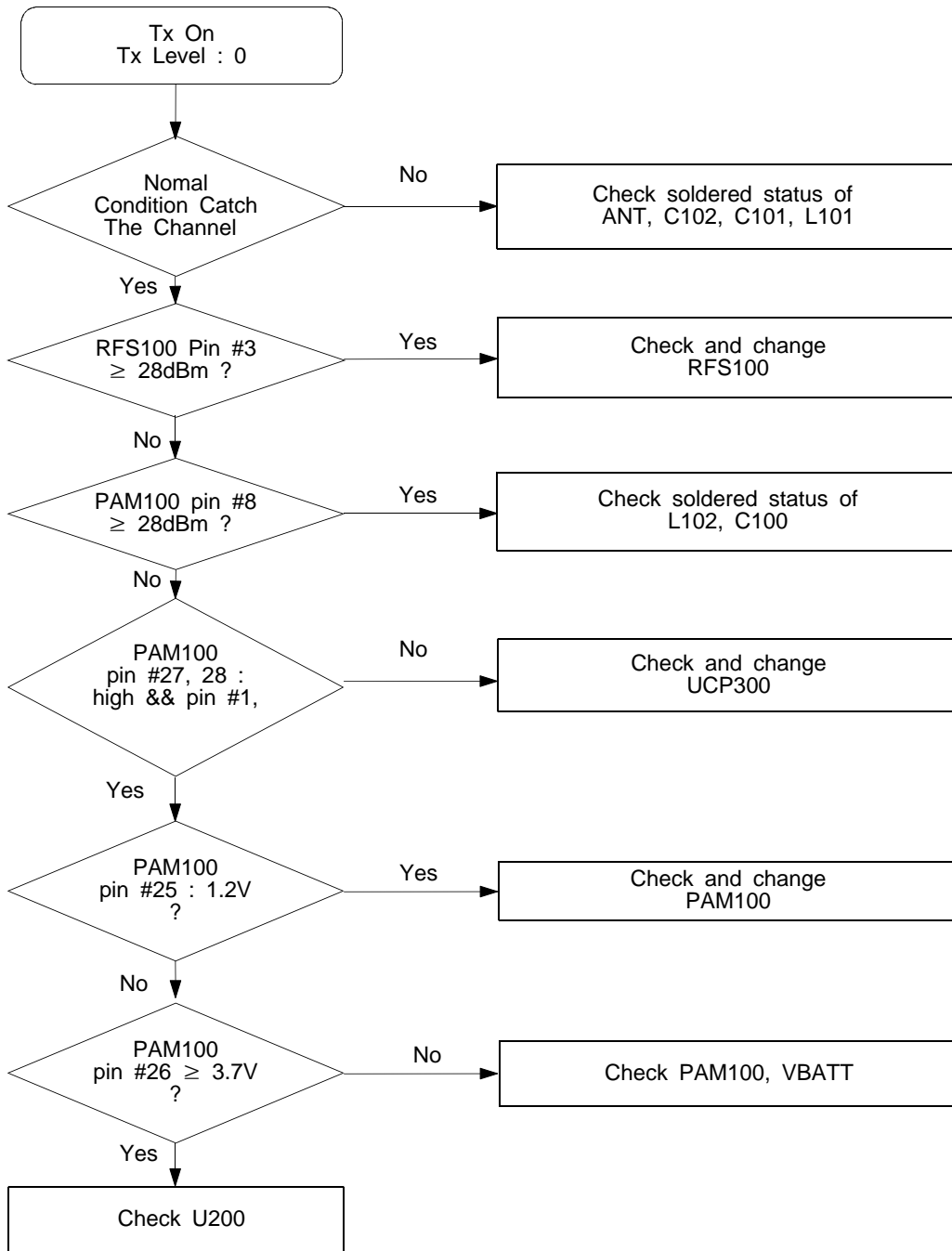

10-2-5. PCS1900 Receiver

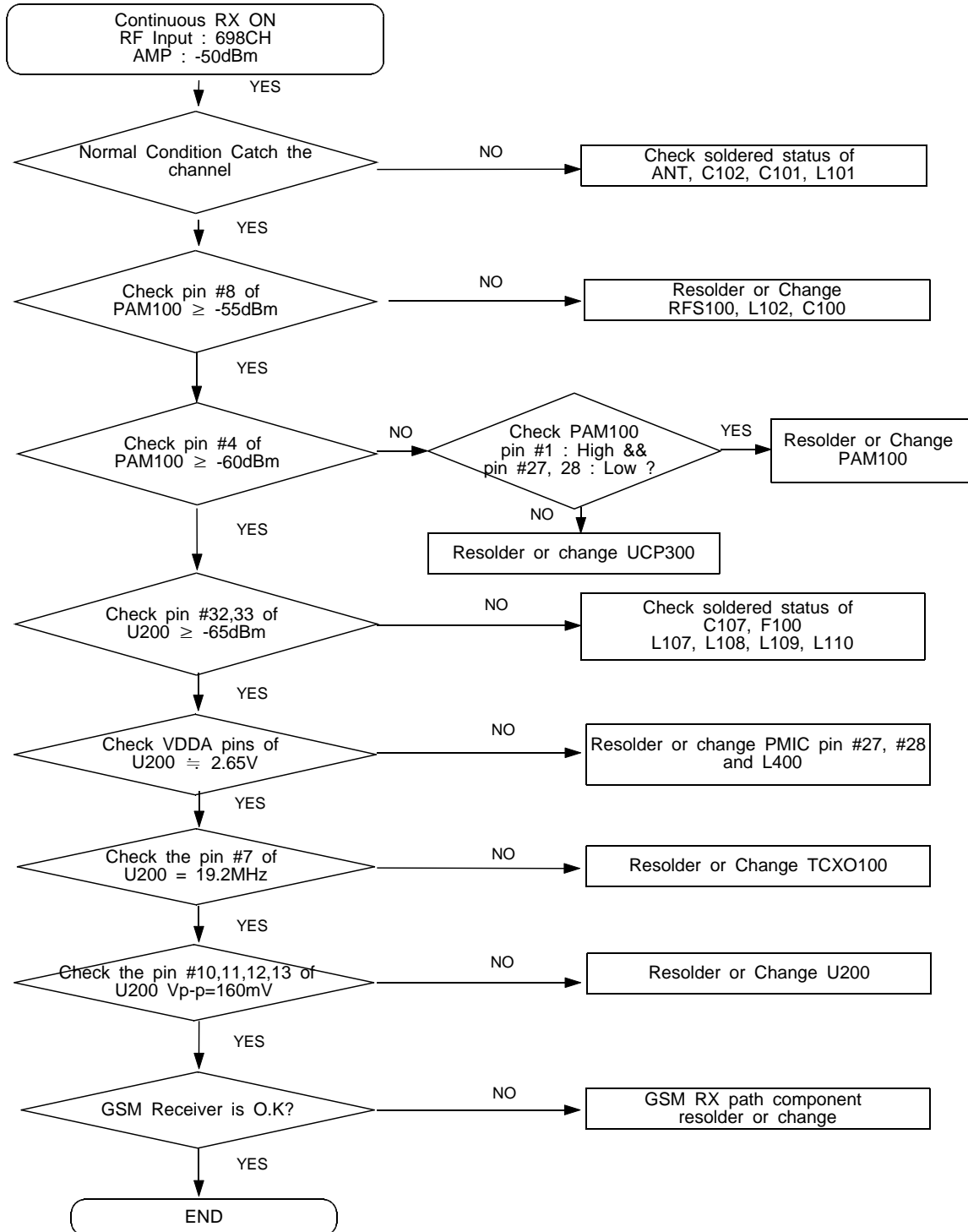



10-2-6. PCS1900 Transmitter

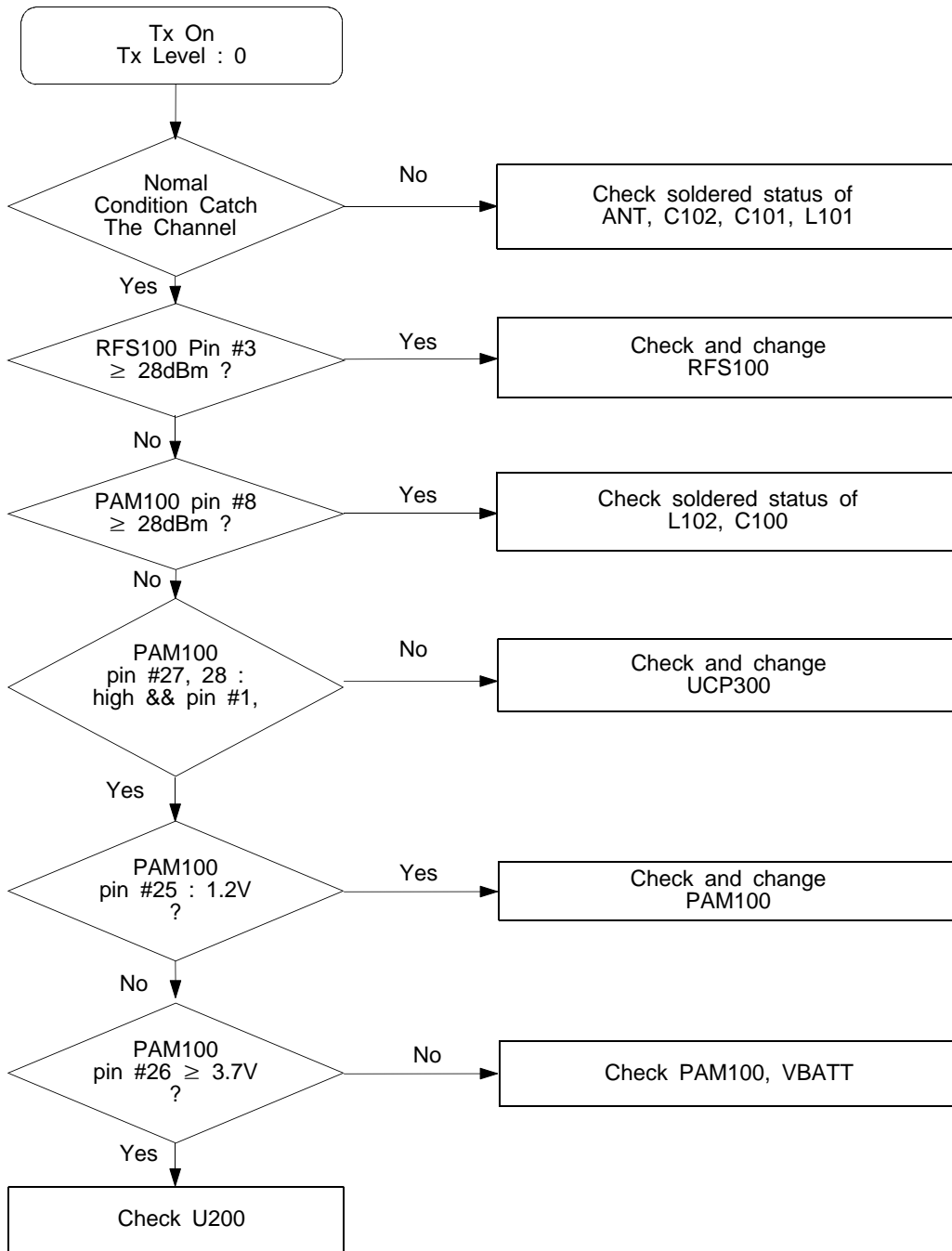

10-2-7. UMTS2100 Receiver

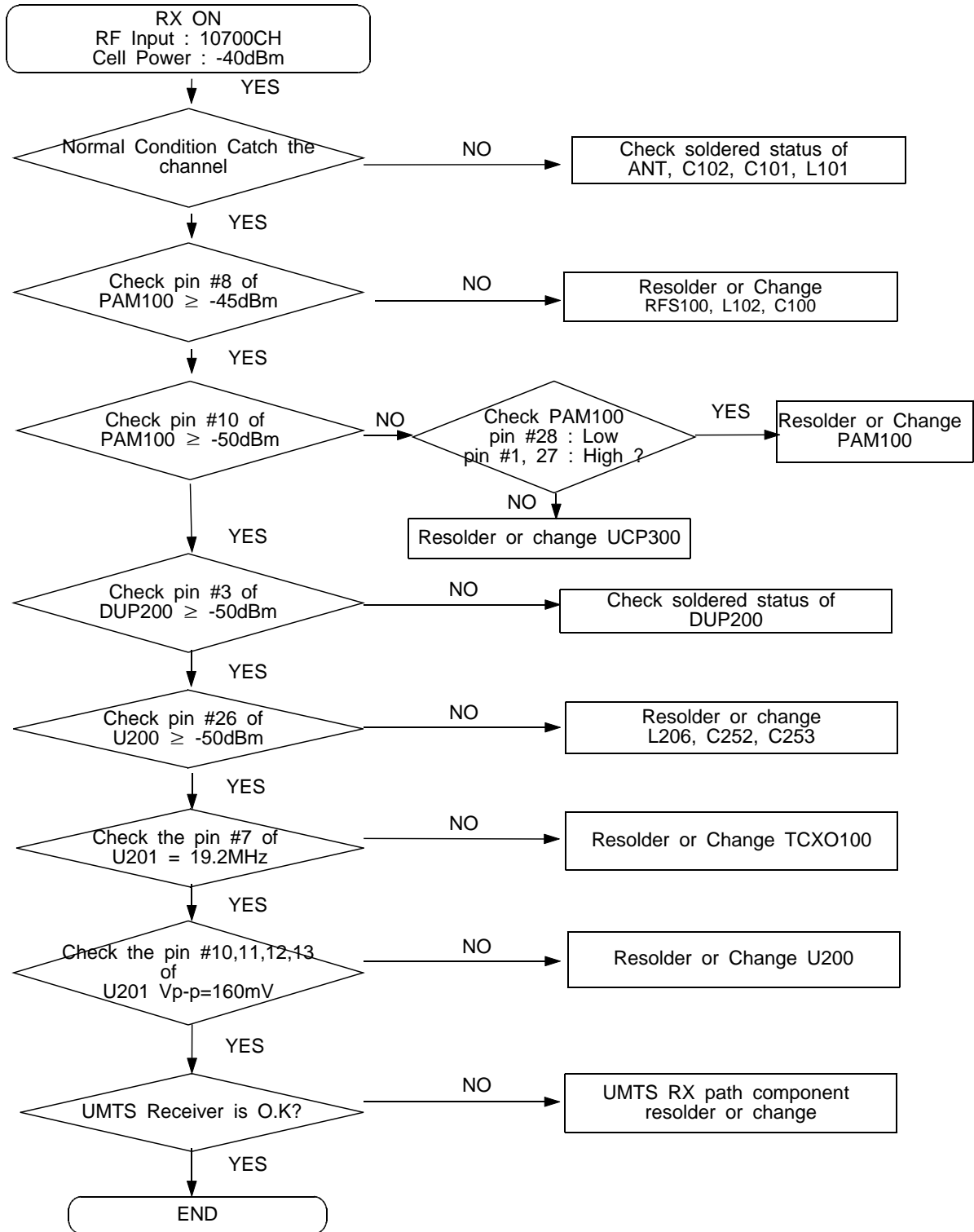

**10-2-8. UMTS2100 Transmitter**

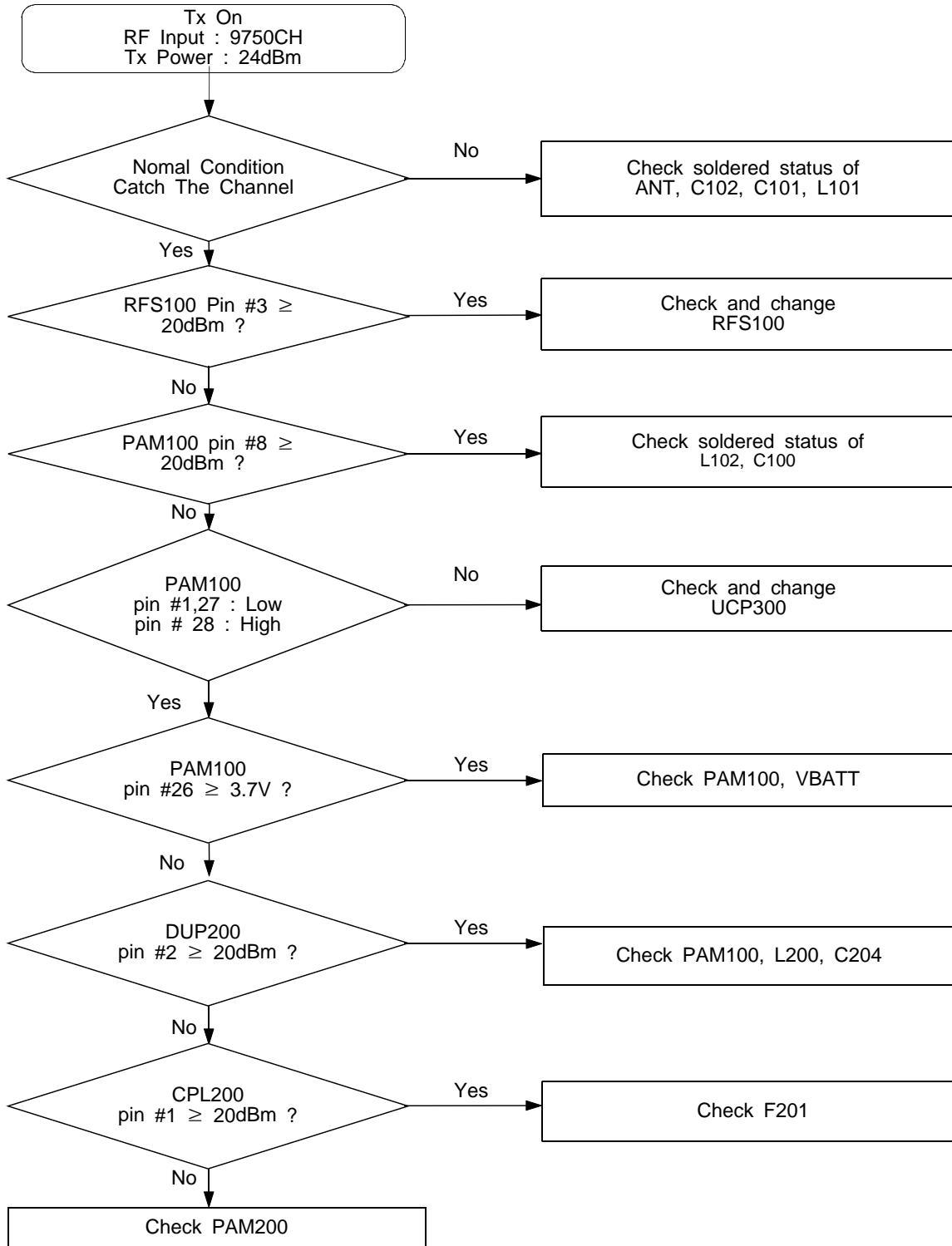

- Schematic for 2G RF

# RT1

RF

SUN-L

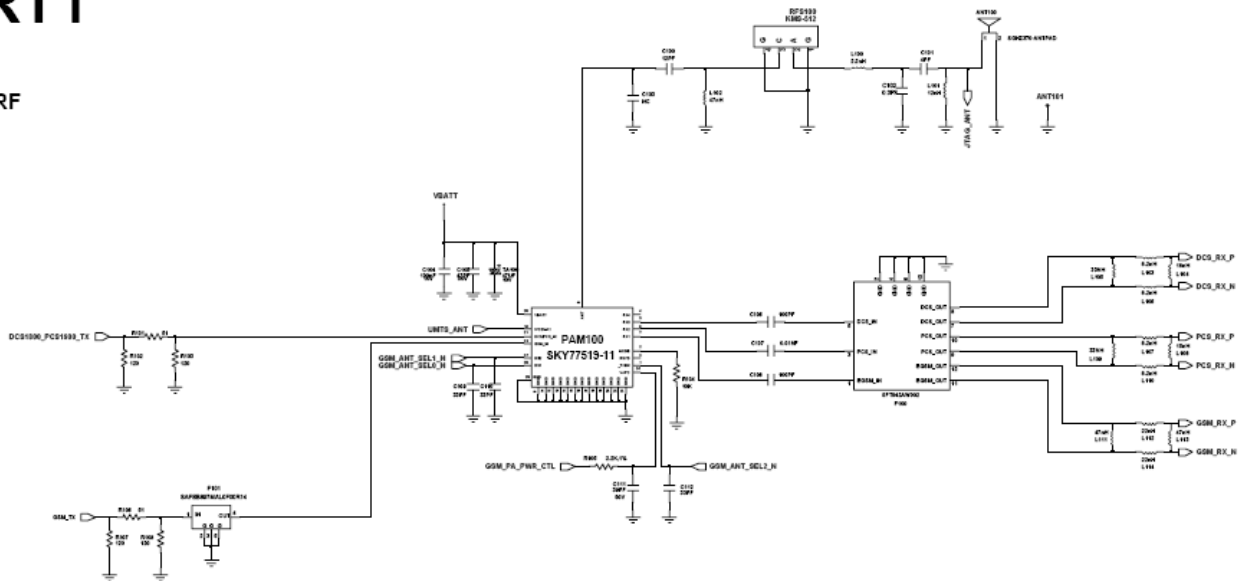

- Schematic for 3G RF

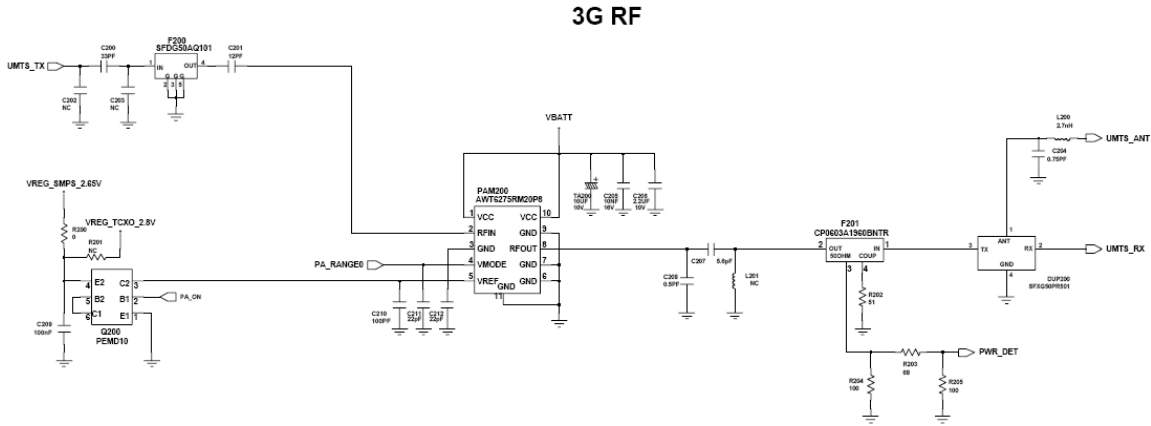

- Schematic for TCXO

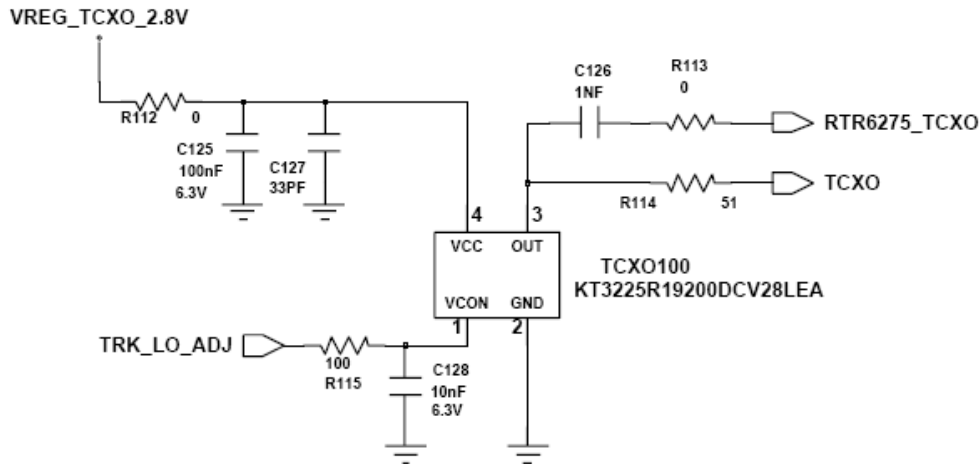



## 10-2-9. BLUETOOTH

① Flow chart of Bluetooth

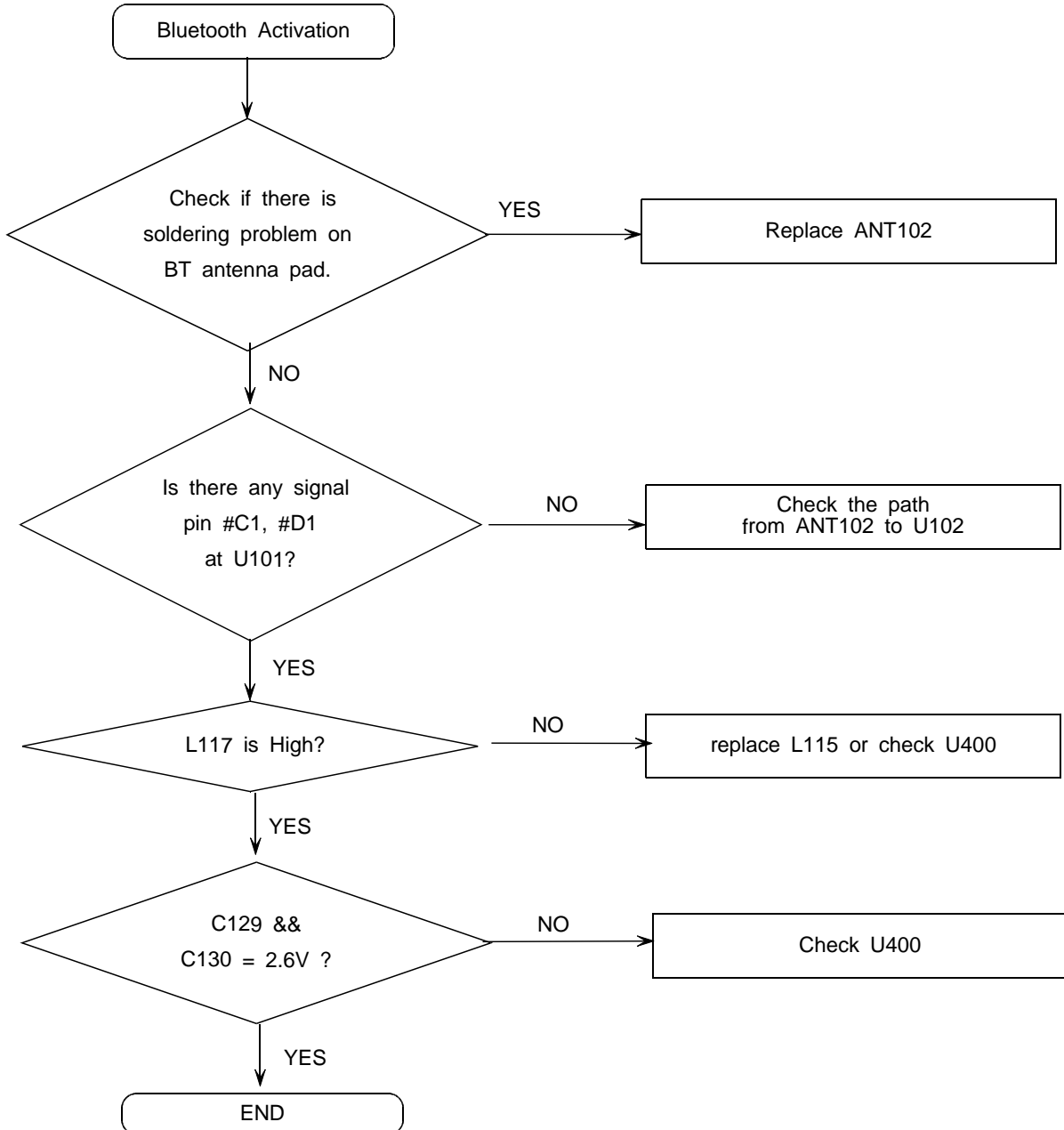

**10-2-10. FM radio**

## ① Flow chart of FM Radio

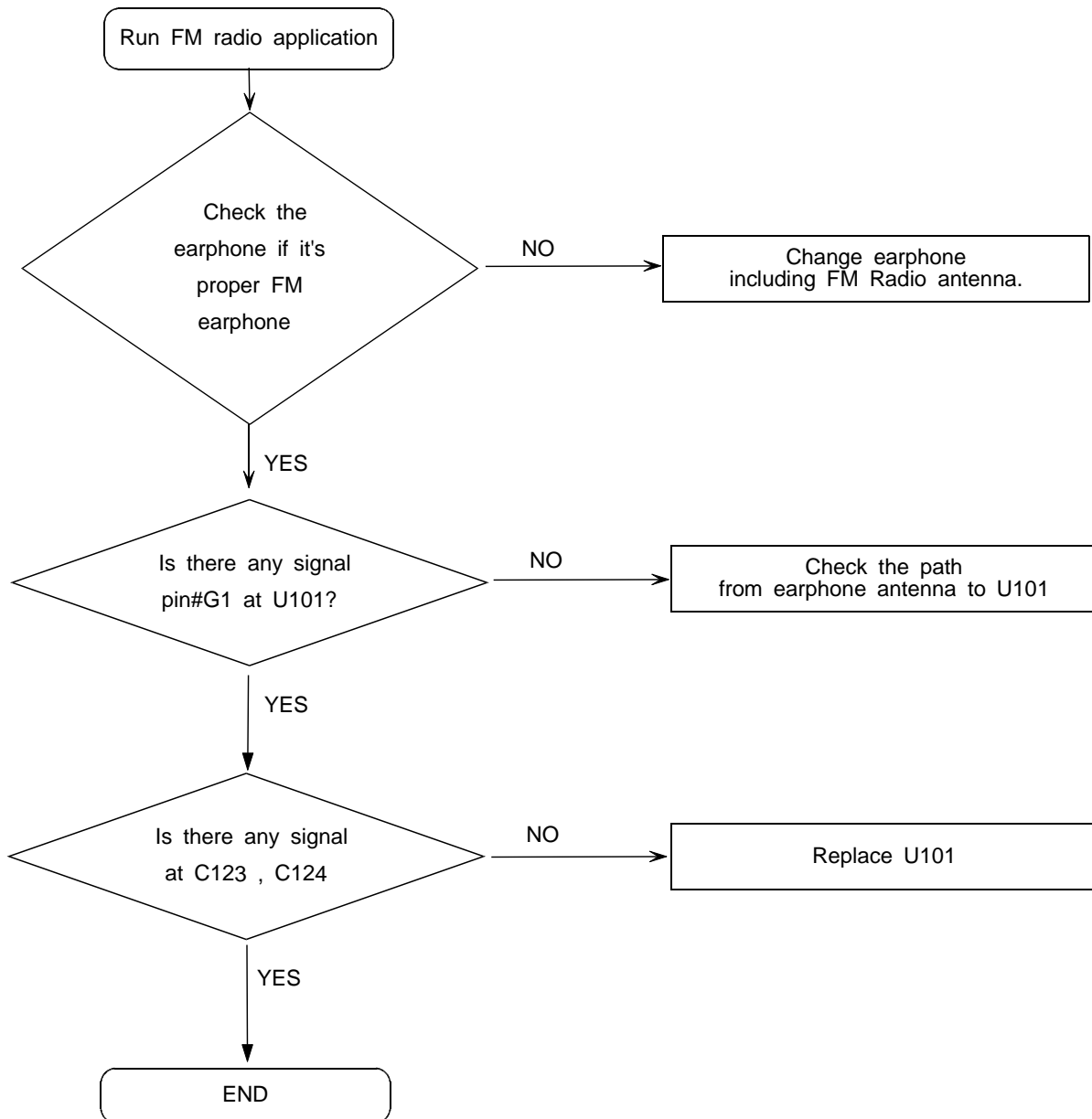



② Schematic for Bluetooth / FM Radio

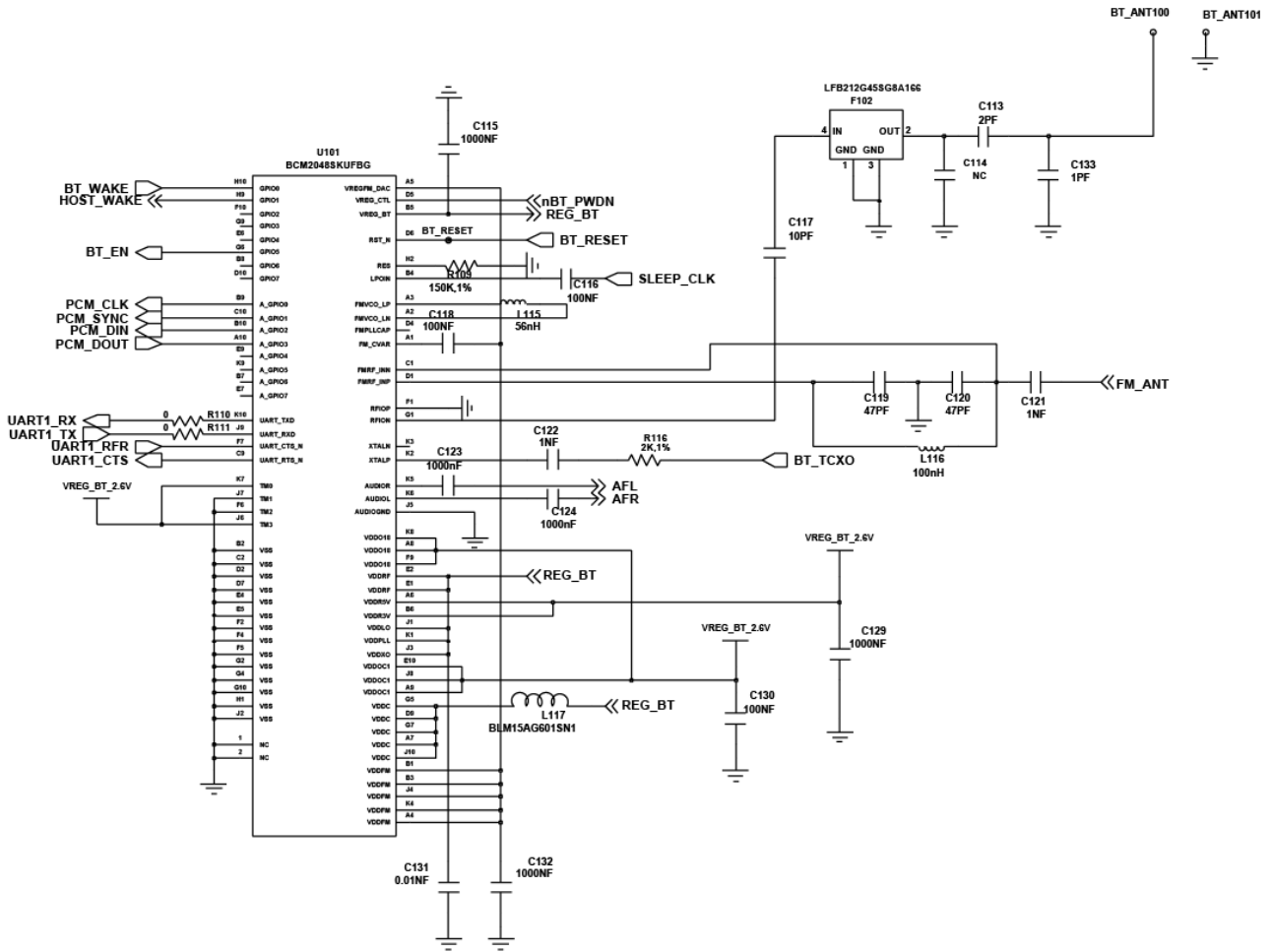

③ Layout for Bluetooth / FM Radio

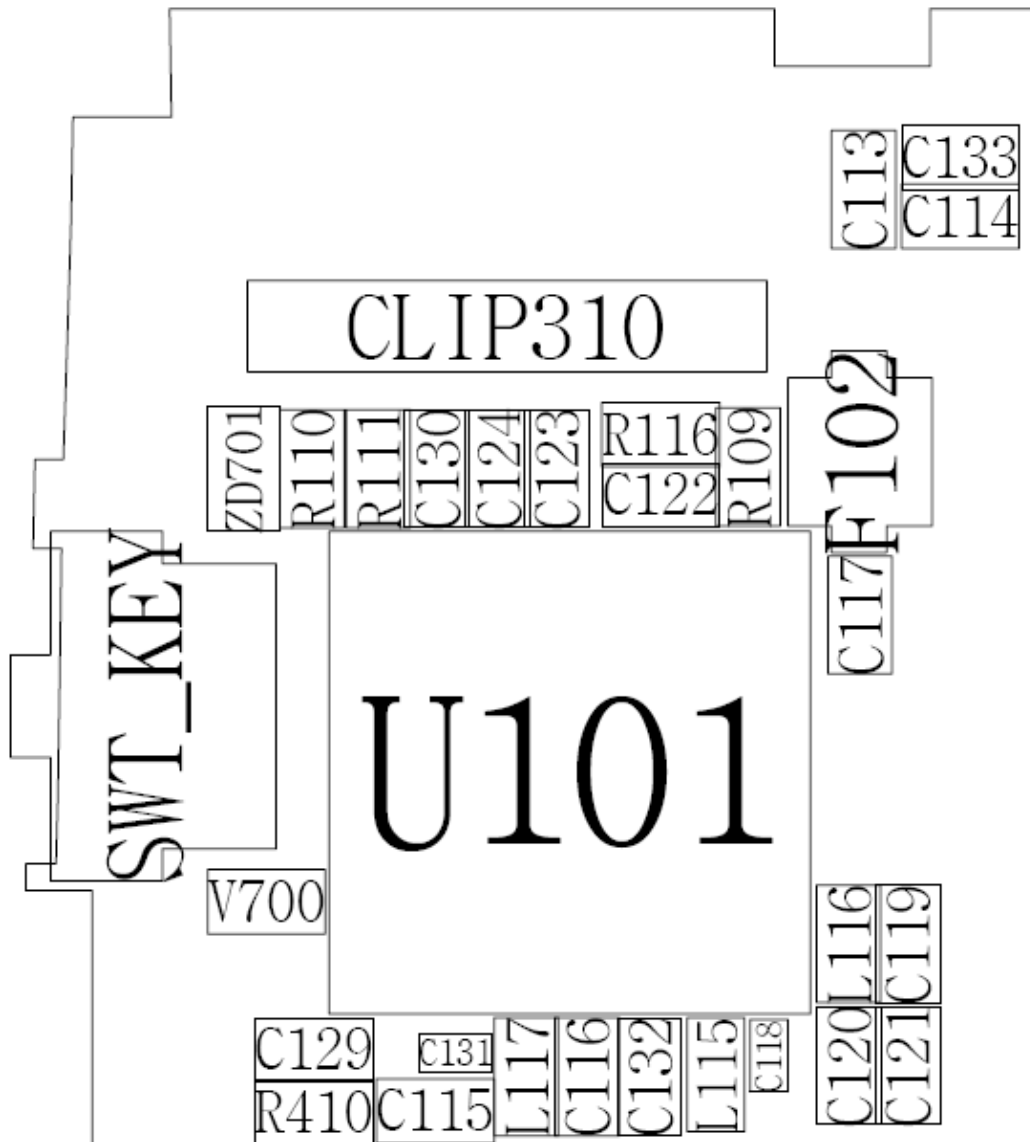

## 4. Array course control

### 4-1. Software Adjustments

<p>Test Jig (GH80-03308A)</p>	<p>Test Cable (GH39-00886A or GH39-00889A)</p>
 A black rectangular test jig with various ports and labels. Labels include 'SAMSUNG ELECTRONICS UMS TEST JIG GH80-03308A', 'TEST PACK', 'USB', 'POWER ON/OFF', '+4.2V', 'UART 1', 'UART 0', 'FEED-BACK', and 'BOOT ON/OFF'. There are several colored LEDs and connectors on the front panel.	 A black cable with a USB connector on one end and a multi-pin connector on the other.
<p>Serial Cable</p>	<p>Power Supply Cable</p>
 A white cable with two multi-pin connectors at both ends.	 A red and black cable with two red and two black wires, each ending in a metal pin connector.
<p>RF Test Cable (GH39-00397A)</p>	<p>DATA CABLE (GH39-00922A or GH39-00922B)</p>
 A black cable with a BNC connector on one end and a multi-pin connector on the other.	 A black cable with a USB connector on one end and a multi-pin connector on the other.

## 4-2. Software Downloading

### 4-2-1. Downloading Binary Files

- Four binary files for downloading L170
- SGH-L170 Mobile Phone
- Data Cable
- Binary file,

### 4-2-2. Pre-requisite for Downloading

- Downloader Program
- SGH-L170 Mobile Phone
- Data Cable
- Binary file,

### 4-2-3. S/W Downloader Program

1. Boot the L170 by pressing 'Power ON key' + 'Number 9 Key' at the same time.  
→ If you do properly, you can see the "DOWNLOAD" mode screen on the LCD.

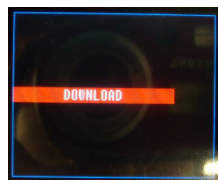

2. Load the binary download program by executing the "[Downloader V5.30.exe](#)".  
→ If you connect the data cable to L170, you can see "COM" port detection sign.

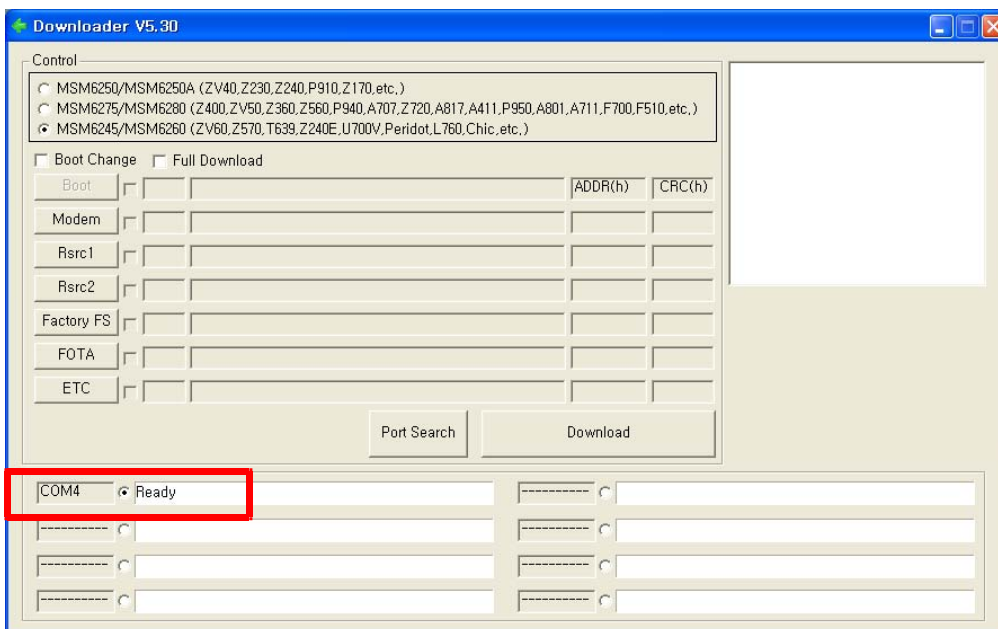

3. Select chipset "MSM6245".

Next, check the "boot change" and check the "full download"

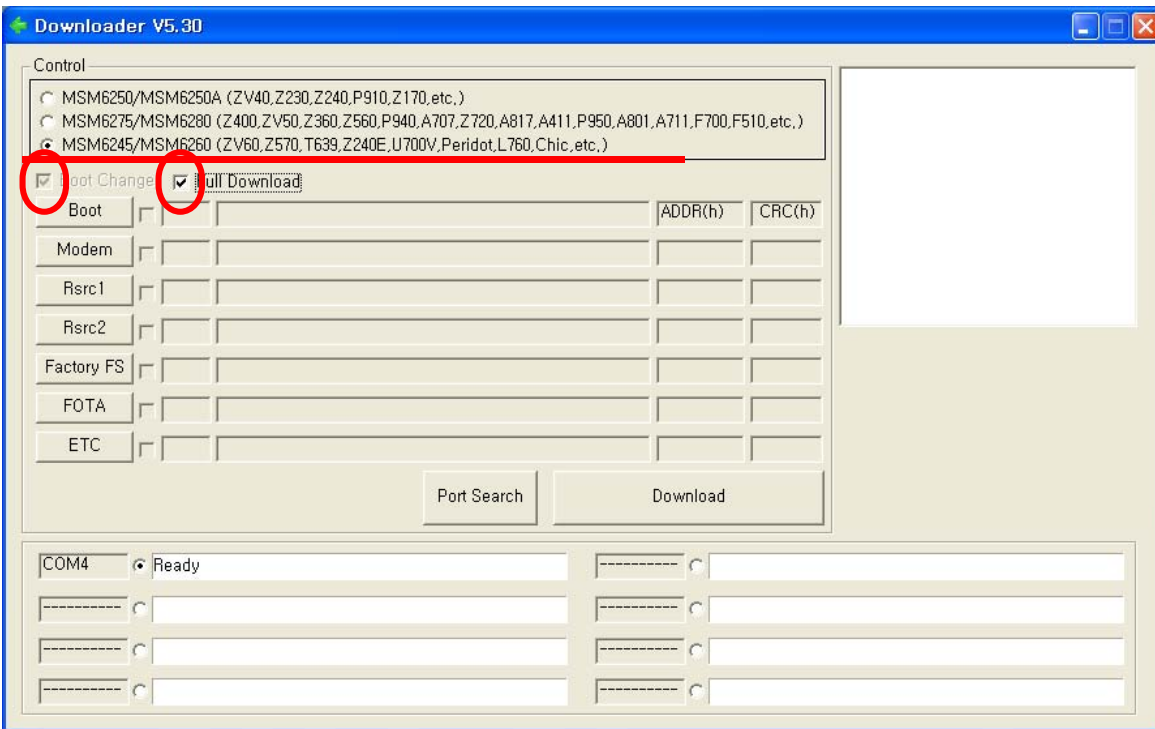

4. Select the binary files. (Boot, Modem, Rsrc1, Rsrc2, Factory FS)

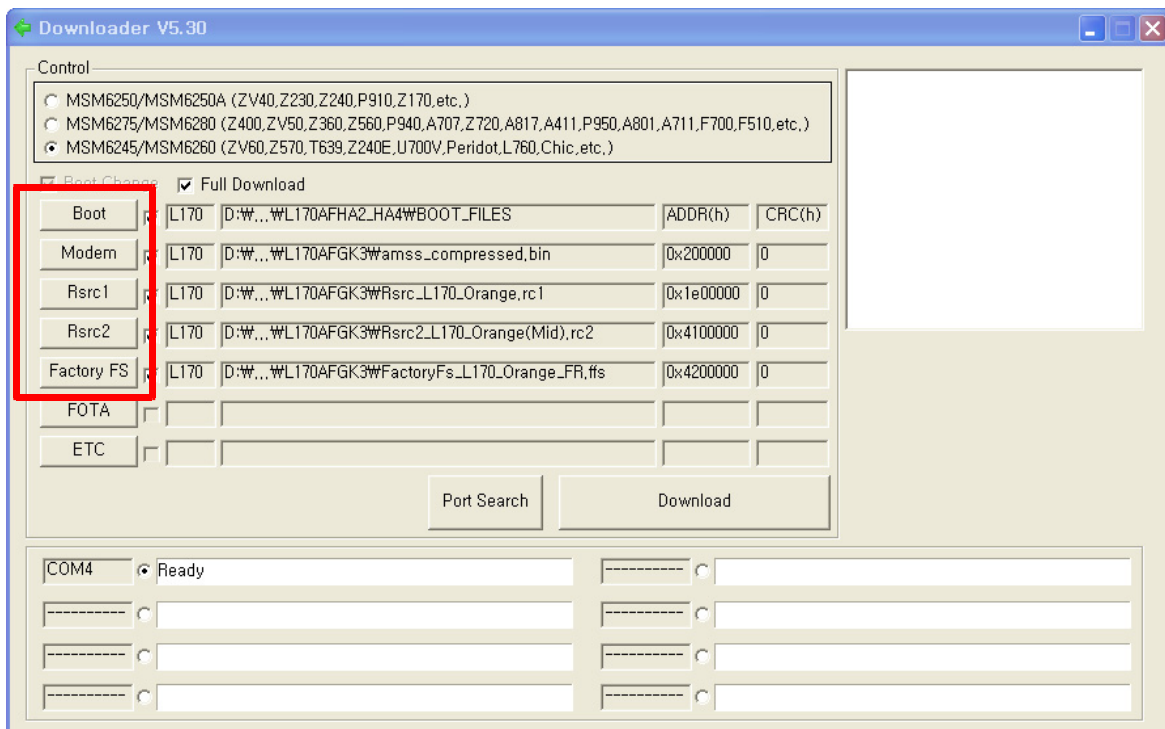

- 5. Now press the button 'Port Search'.  
→ Model name is displayed additionally in COM port screen.

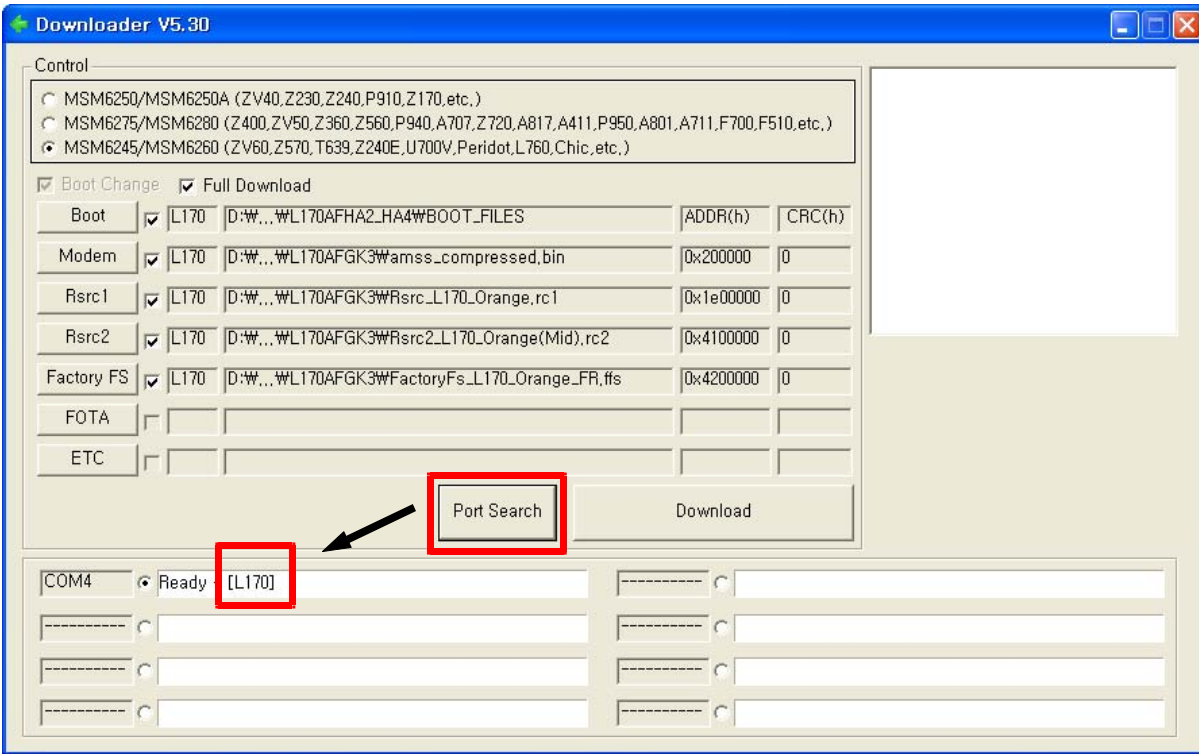

- 6. Now click the button 'DownLoad'.  
→ Download progressing bar is starting.

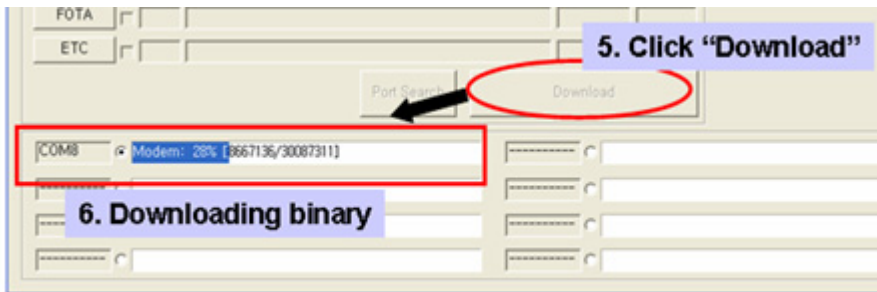

- 7. When downloading is complete, UE reboot automatically.  
→ If there is difference in FactoryFs.bin, UE will format file system automatically.

## 8. Block Diagrams

### 8-1. RF Solution Block Diagram

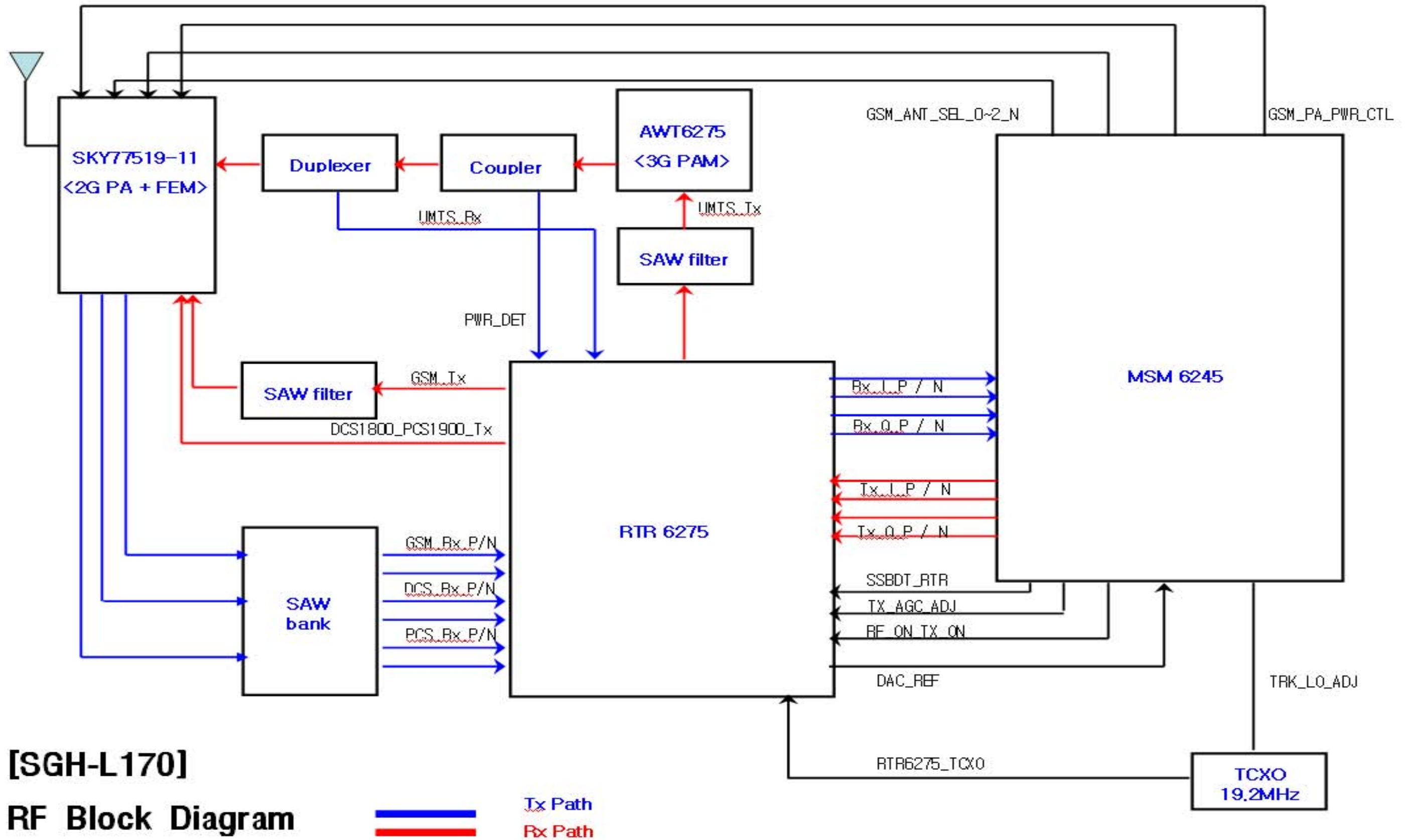



8-2. Base Band Solution Block Diagram

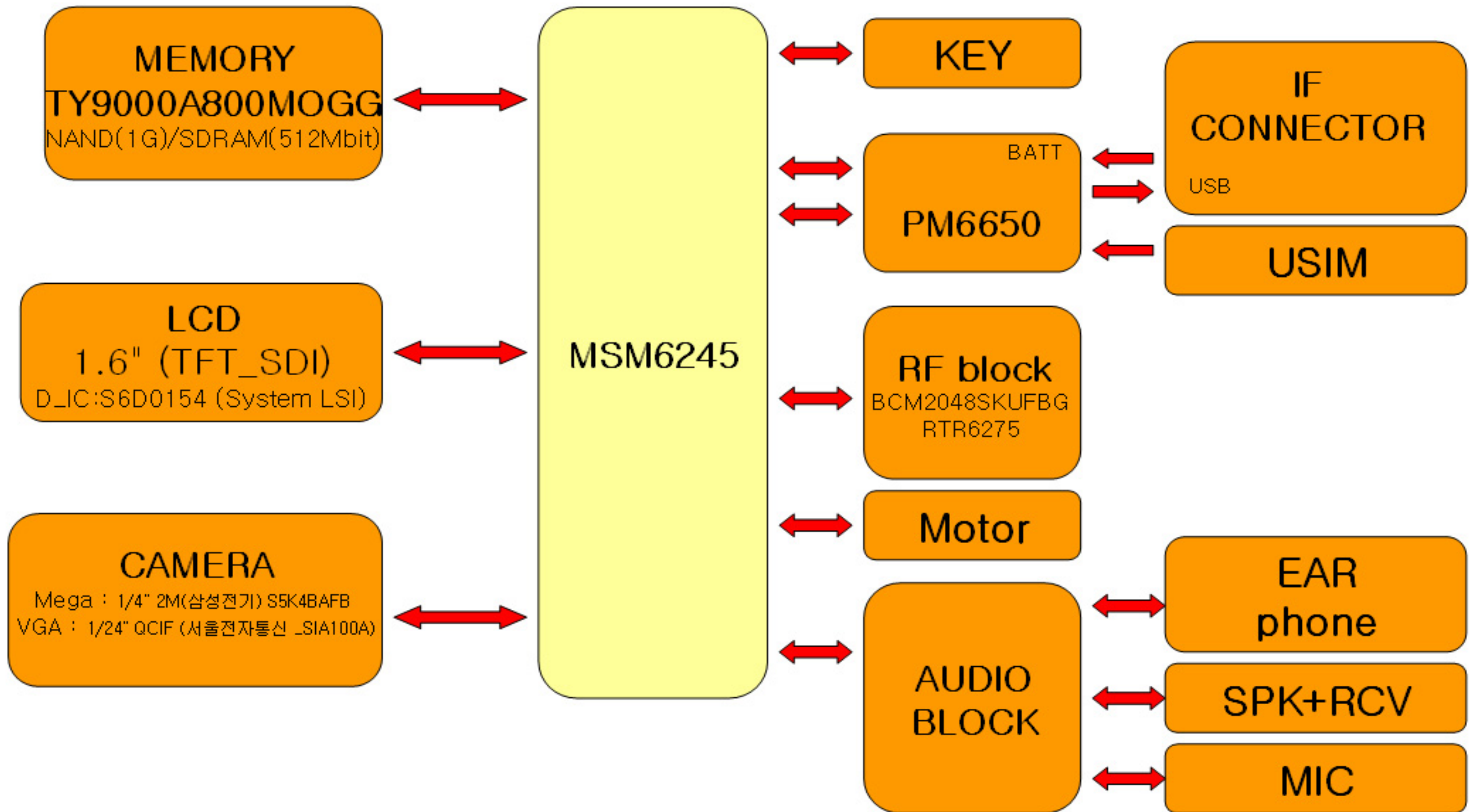



8-3. Power Block Diagram

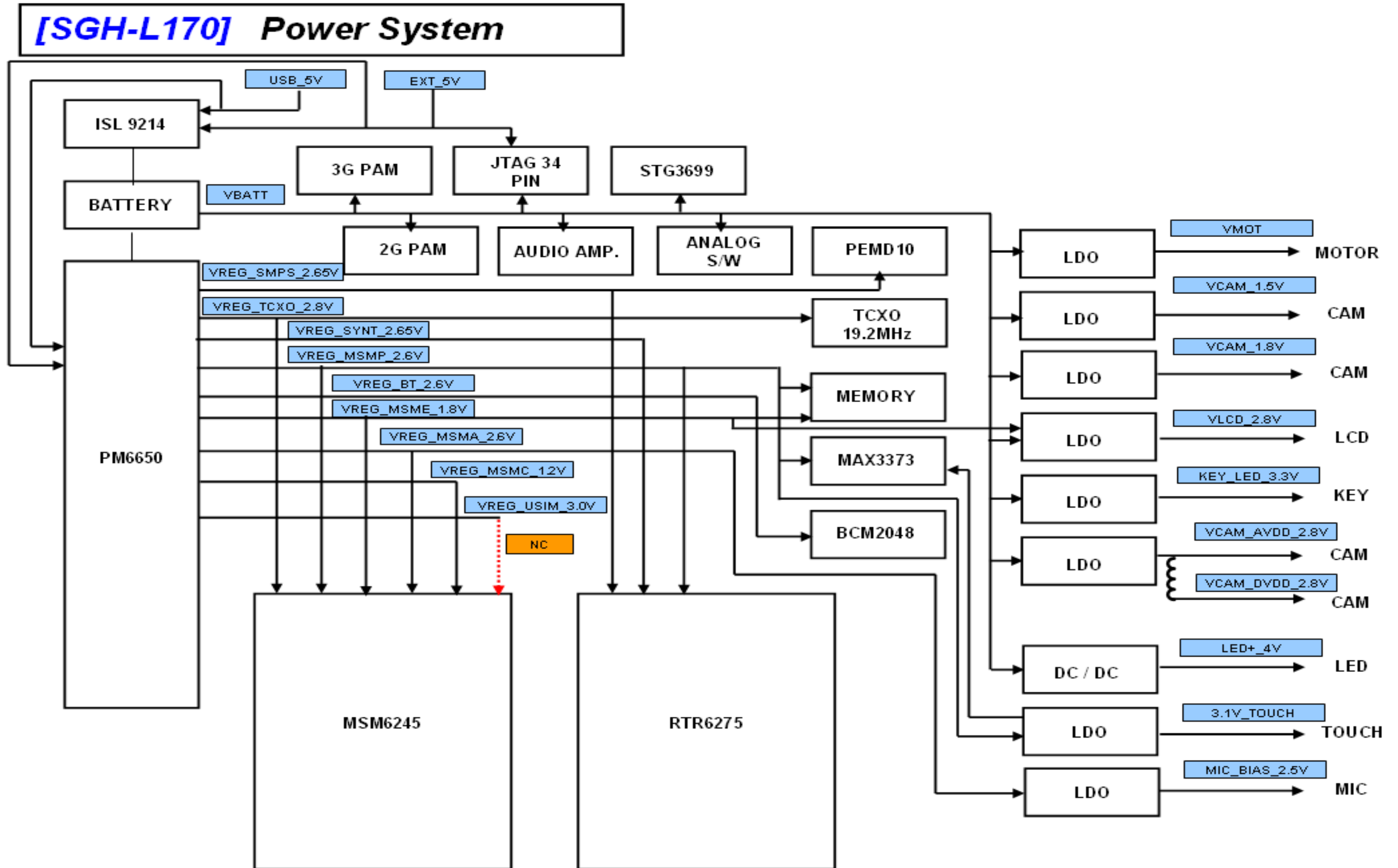

# 9. PCB Diagrams

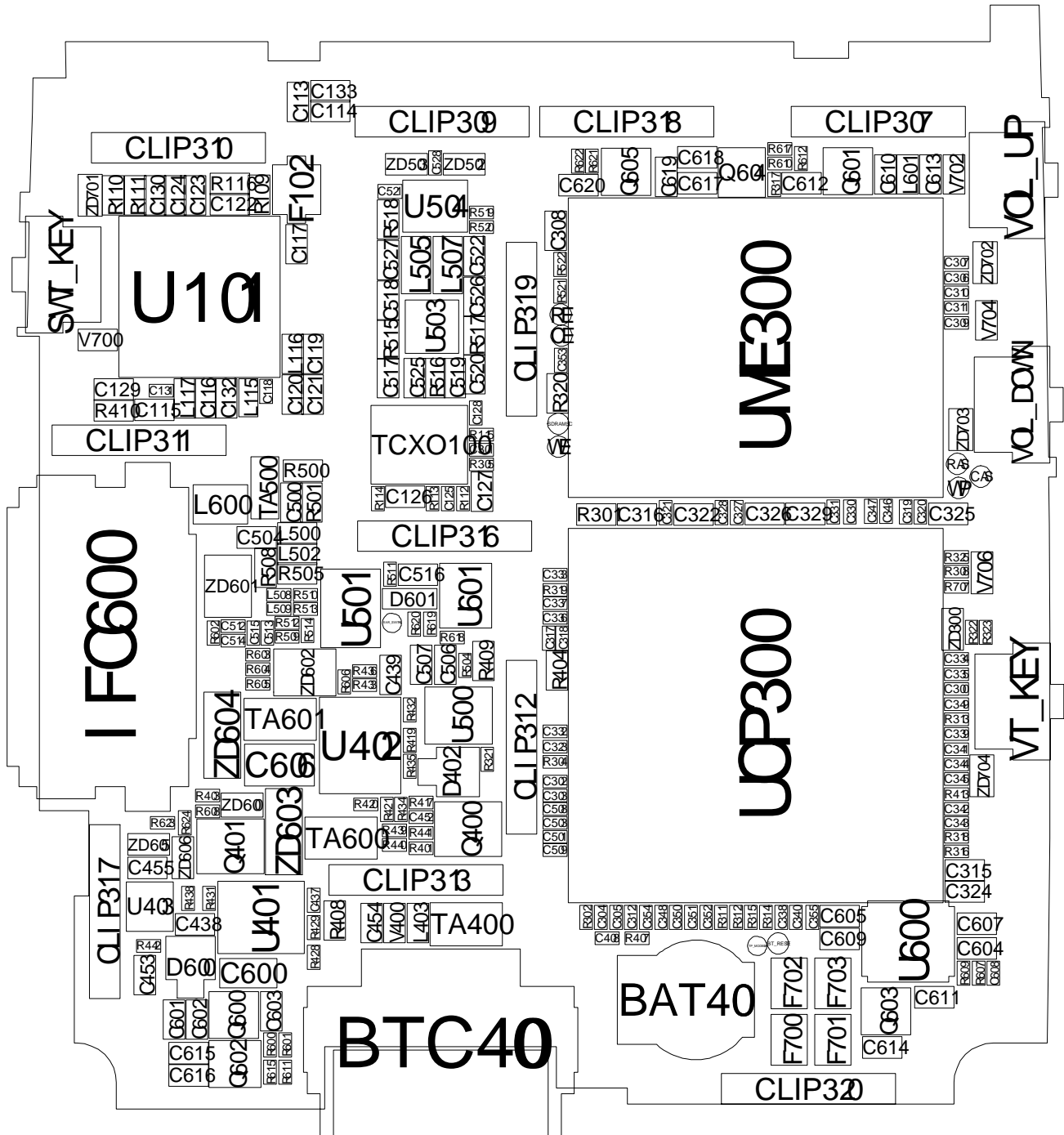

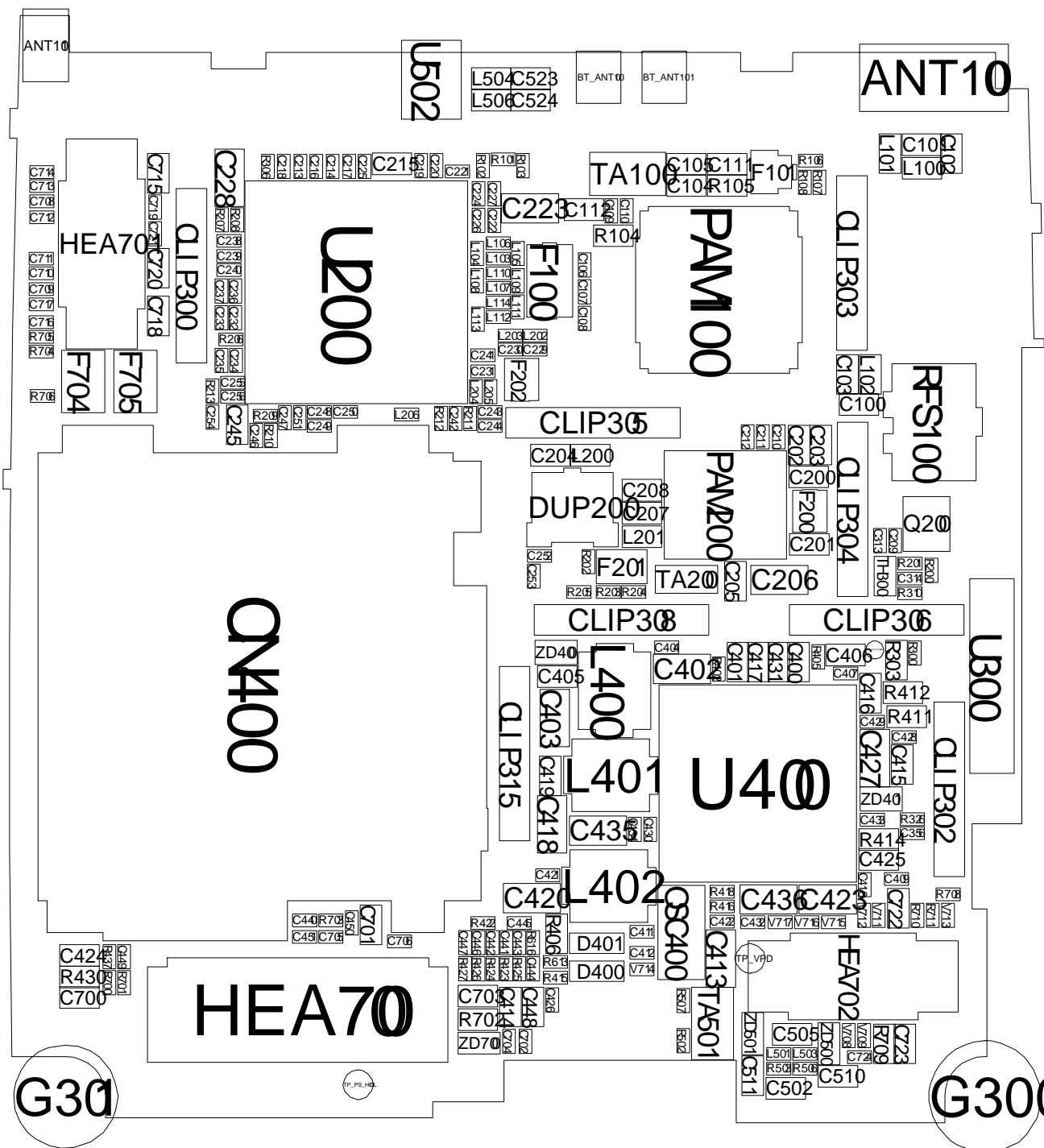

---

## 3. Product Function

---

### Main Function

#### [ H/W ]

- Size : 102.3 x 45.8 x 10.7 mm
- Weight : 83 g
- Band : GSM 900 / 1800 / 1900  
UMTS 2100
- Battery : 880mAh / Inner (653039H)
- BB : Qualcomm MSM6245
- RF : Qualcomm RTR6275
- LCD : 1.6" 220\*176 262K TFT (SDI)
- Memory : 1G (NAND) +512Mb (SDRAM)  
\* external : microSD ( T-Flash )
- Camera : 2.0M CMOS (LSI)  
VGA QCIF (서울전자통신)
- TOUCH KEY : SYNAPTICS
- BT/FM : Braodcom BCM2048  
\* FM Radio with RDS  
\* Bluetooth 2.0

#### [ S/W ]

- Video Telephony / Streaming
- USB 2.0
- MP3 / 72 Poly Melody
- WAP2.0, MPEG4
- MIDP 2.0 / cldc 1.1
- Mobile Blog
- Rss Reader
- FM Radio with RDS
- Music Search
- Bluetooth 2.0
- Auto Time Setting,
- GPRS/EDGE
- MMS / EMS

---

## 11. Reference data

---

### 11-1. Reference Abbreviate

**AAC:** Advanced Audio Coding.

**AVC :** Advanced Video Coding.

**BER :** Bit Error Rate

**BPSK:** Binary Phase Shift Keying

**CA :** Conditional Access

**CDM :** Code Division Multiplexing

**C/I :** Carrier to Interference

**DMB :** Digital Multimedia Broadcasting

**EN :** European Standard

**ES :** Elementary Stream

**ETSI:** European Telecommunications Standards Institute

**MPEG:** Moving Picture Experts Group

**PN :** Pseudo-random Noise

**PS :** Pilot Symbol

**QPSK:** Quadrature Phase Shift Keying

**RS :** Reed-Solomon

**SI :** Service Information

**TDM :** Time Division Multiplexing

**TS :** Transport Stream

---

# 1. Safety Precautions

---

## 1-1. Repair Precaution

- Repair in Shield Box, during detailed tuning.  
Take specially care of tuning or test,  
because specipcty of cellular phone is sensitive for surrounding interference(RF noise).
- Be careful to use a kind of magnetic object or tool,  
because performance of parts is damaged by the influence of manetic force.
- Surely use a standard screwdriver when you disassemble this product,  
otherwise screw will be worn away.
- Use a thicken twisted wire when you measure level.  
A thicken twisted wire has low resistance, therefore error of measurement is few.
- Repair after separate Test Pack and Set because for short danger (for example an  
overcurrent and furious flames of parts etc) when you repair board in condition of  
connecting Test Pack and tuning on.
- Take specially care of soldering, because Land of PCB is small and weak in heat.
- Surely tune on/off while using AC power plug, because a repair of battery charger is  
dangerous when tuning ON/OFF PBA and Connector after disassembling charger.
- Don't use as you pleases after change other material than replacement registered on SEC  
System.  
Otherwise engineer in charge isn't charged with problem that you don't keep this rules.

## 1-2. ESD(Electrostatically Sensitive Devices) Precaution

Several semiconductor may be damaged easily by static electricity. Such parts are called by ESD(Electrostatically Sensitive Devices), for example IC,BGA chip etc. Read Precaution below. You can prevent from ESD damage by static electricity.

- Remove static electricity remained your body before you touch semiconductor or parts with semiconductor. There are ways that you touch an earthed place or wear static electricity prevention string on wrist.
- Use earthed soldering steel when you connect or disconnect ESD.
- Use soldering removing tool to break static electricity. , otherwise ESD will be damaged by static electricity.
- Don't unpack until you set up ESD on product. Because most of ESD are packed by box and aluminum plate to have conductive power,they are prevented from static electricity.
- You must maintain electric contact between ESD and place due to be set up until ESD is connected completely to the proper place or a circuit board.

## 6. MAIN Electrical Parts List

SEC CODE	Design LOC	Discription	STATUS
0403-001547	ZD603	DIODE-ZENER	SA
0403-001547	ZD604	DIODE-ZENER	SA
0404-001153	D400	DIODE-SCHOTTKY	SA
0404-001153	D401	DIODE-SCHOTTKY	SA
0404-001153	D601	DIODE-SCHOTTKY	SA
0406-001208	ZD601	DIODE-TVS	SA
0406-001208	ZD602	DIODE-TVS	SA
0406-001223	V706	DIODE-TVS	SA
0406-001223	ZD300	DIODE-TVS	SA
0406-001223	ZD500	DIODE-TVS	SA
0406-001223	ZD501	DIODE-TVS	SA
0406-001223	ZD502	DIODE-TVS	SA
0406-001223	ZD503	DIODE-TVS	SA
0406-001231	ZD605	DIODE-TVS	SA
0406-001231	ZD606	DIODE-TVS	SA
0406-001254	ZD600	DIODE-TVS	SA
0406-001254	ZD701	DIODE-TVS	SA
0406-001254	ZD702	DIODE-TVS	SA
0406-001254	ZD703	DIODE-TVS	SA
0406-001254	ZD704	DIODE-TVS	SA
0407-001002	D402	DIODE-ARRAY	SA
0407-001002	D600	DIODE-ARRAY	SA
0504-000168	Q400	TR-DIGITAL	SA
0504-000168	Q401	TR-DIGITAL	SA
0504-001151	Q200	TR-DIGITAL	SA
1001-001336	U504	IC-ANALOG SWITCH	SA
1001-001336	U601	IC-ANALOG SWITCH	SA
1001-001405	U501	IC-ANALOG MULTIPLEX	SA
1006-001322	U401	IC-LINE TRANSCEIVER	SA
1108-000144	UME300	IC-MCP	SA
1201-002304	U503	IC-AUDIO AMP	SA
1201-002305	PAM200	IC-POWER AMP	SA
1201-002570	PAM100	IC-POWER AMP	SA
1203-002624	U500	IC-POSI.FIXED REG.	SA
1203-003340	U403	IC-POSI.FIXED REG.	SA
1203-003432	Q605	IC-POSI.FIXED REG.	SA



SEC CODE	Design LOC	Discription	STATUS
1203-003523	Q601	IC-POSI.FIXED REG.	SA
1203-003523	Q603	IC-POSI.FIXED REG.	SA
1203-003708	U600	IC-DC/DC CONVERTER	SA
1203-003737	Q602	IC-POSI.FIXED REG.	SA
1203-003754	Q600	IC-POSI.FIXED REG.	SA
1203-003791	Q604	IC-POSI.FIXED REG.	SA
1203-004518	U402	IC-BATTERY	SA
1203-004926	U400	IC-POWER SUPERVISOR	SA
1205-003206	UCP300	IC-MODEM	SA
1205-003216	U101	IC-TRANSCEIVER	SA
1205-003285	U200	IC-TRANSCEIVER	SA
1404-001224	TH300	THERMISTOR-NTC	SA
1405-001110	V400	VARISTOR	SA
1405-001133	V700	VARISTOR	SA
1405-001133	V702	VARISTOR	SA
1405-001133	V704	VARISTOR	SA
1405-001201	V708	VARISTOR	SA
1405-001201	V709	VARISTOR	SA
1405-001201	V711	VARISTOR	SA
1405-001201	V712	VARISTOR	SA
1405-001201	V713	VARISTOR	SA
1405-001201	V714	VARISTOR	SA
1405-001201	V715	VARISTOR	SA
1405-001201	V716	VARISTOR	SA
1405-001201	V717	VARISTOR	SA
2007-000138	R518	R-CHIP	SA
2007-000141	R505	R-CHIP	SA
2007-000148	R104	R-CHIP	SA
2007-000148	R301	R-CHIP	SA
2007-000152	R303	R-CHIP	SA
2007-000171	R110	R-CHIP	SA
2007-000171	R111	R-CHIP	SA
2007-000171	R320	R-CHIP	SA
2007-000171	R404	R-CHIP	SA
2007-000171	R406	R-CHIP	SA
2007-000171	R408	R-CHIP	SA

SEC CODE	Design LOC	Discription	STATUS
2007-000171	R409	R-CHIP	SA
2007-000171	R410	R-CHIP	SA
2007-000171	R411	R-CHIP	SA
2007-000171	R412	R-CHIP	SA
2007-000171	R508	R-CHIP	SA
2007-000171	R515	R-CHIP	SA
2007-000171	R709	R-CHIP	SA
2007-001119	R500	R-CHIP	SA
2007-007308	R516	R-CHIP	SA
2007-007308	R517	R-CHIP	SA
2007-007317	R105	R-CHIP	SA
2007-007468	R414	R-CHIP	SA
2007-007489	R109	R-CHIP	SA
2007-007528	R501	R-CHIP	SA
2007-007741	R302	R-CHIP	SA
2007-007741	R310	R-CHIP	SA
2007-007741	R319	R-CHIP	SA
2007-007741	R321	R-CHIP	SA
2007-007766	R116	R-CHIP	SA
2007-008044	R203	R-CHIP	SA
2007-008045	R115	R-CHIP	SA
2007-008045	R204	R-CHIP	SA
2007-008045	R213	R-CHIP	SA
2007-008045	R511	R-CHIP	SA
2007-008045	R618	R-CHIP	SA
2007-008045	R706	R-CHIP	SA
2007-008046	R102	R-CHIP	SA
2007-008046	R103	R-CHIP	SA
2007-008046	R107	R-CHIP	SA
2007-008046	R108	R-CHIP	SA
2007-008049	R305	R-CHIP	SA
2007-008053	R432	R-CHIP	SA
2007-008055	R300	R-CHIP	SA
2007-008055	R317	R-CHIP	SA
2007-008055	R322	R-CHIP	SA
2007-008055	R325	R-CHIP	SA

SEC CODE	Design LOC	Discription	STATUS
2007-008055	R403	R-CHIP	SA
2007-008055	R419	R-CHIP	SA
2007-008055	R420	R-CHIP	SA
2007-008055	R421	R-CHIP	SA
2007-008055	R422	R-CHIP	SA
2007-008055	R438	R-CHIP	SA
2007-008055	R441	R-CHIP	SA
2007-008055	R609	R-CHIP	SA
2007-008055	R619	R-CHIP	SA
2007-008419	R440	R-CHIP	SA
2007-008419	R602	R-CHIP	SA
2007-008419	R603	R-CHIP	SA
2007-008419	R605	R-CHIP	SA
2007-008419	R606	R-CHIP	SA
2007-008477	R401	R-CHIP	SNA
2007-008478	R503	R-CHIP	SA
2007-008478	R506	R-CHIP	SA
2007-008483	R402	R-CHIP	SA
2007-008483	R429	R-CHIP	SA
2007-008483	R601	R-CHIP	SA
2007-008483	R612	R-CHIP	SA
2007-008483	R615	R-CHIP	SA
2007-008483	R622	R-CHIP	SA
2007-008486	R415	R-CHIP	SA
2007-008486	R417	R-CHIP	SA
2007-008486	R620	R-CHIP	SA
2007-008516	R405	R-CHIP	SA
2007-008516	R423	R-CHIP	SA
2007-008516	R424	R-CHIP	SA
2007-008516	R425	R-CHIP	SA
2007-008516	R426	R-CHIP	SA
2007-008516	R427	R-CHIP	SA
2007-008516	R439	R-CHIP	SA
2007-008516	R710	R-CHIP	SA
2007-008516	R711	R-CHIP	SA
2007-008531	R211	R-CHIP	SA

SEC CODE	Design LOC	Discription	STATUS
2007-008542	R112	R-CHIP	SA
2007-008542	R113	R-CHIP	SA
2007-008542	R200	R-CHIP	SA
2007-008542	R207	R-CHIP	SA
2007-008542	R210	R-CHIP	SA
2007-008542	R306	R-CHIP	SA
2007-008542	R504	R-CHIP	SA
2007-008542	R509	R-CHIP	SA
2007-008542	R514	R-CHIP	SA
2007-008542	R613	R-CHIP	SA
2007-008542	R617	R-CHIP	SA
2007-008542	R701	R-CHIP	SA
2007-008542	R703	R-CHIP	SA
2007-008542	R707	R-CHIP	SA
2007-008542	R708	R-CHIP	SA
2007-008544	R212	R-CHIP	SA
2007-008544	R502	R-CHIP	SA
2007-008544	R507	R-CHIP	SA
2007-008548	R604	R-CHIP	SA
2007-008588	R704	R-CHIP	SA
2007-008588	R705	R-CHIP	SA
2007-008647	R208	R-CHIP	SA
2007-008648	R437	R-CHIP	SA
2007-008648	R600	R-CHIP	SA
2007-008648	R610	R-CHIP	SA
2007-008648	R611	R-CHIP	SA
2007-008648	R621	R-CHIP	SA
2007-008774	R206	R-CHIP	SA
2007-008774	R209	R-CHIP	SA
2007-008786	R323	R-CHIP	SA
2007-008806	R101	R-CHIP	SA
2007-008806	R106	R-CHIP	SA
2007-008806	R114	R-CHIP	SA
2007-008806	R202	R-CHIP	SA
2007-008806	R308	R-CHIP	SA
2007-008806	R326	R-CHIP	SA

SEC CODE	Design LOC	Discription	STATUS
2007-008806	R413	R-CHIP	SA
2007-008809	R407	R-CHIP	SNA
2007-008964	R430	R-CHIP	SA
2007-009111	R608	R-CHIP	SA
2007-009111	R623	R-CHIP	SA
2007-009111	R624	R-CHIP	SA
2007-009112	R521	R-CHIP	SNA
2007-009154	R519	R-CHIP	SNA
2007-009154	R520	R-CHIP	SNA
2007-009168	R522	R-CHIP	SA
2007-009168	R607	R-CHIP	SA
2007-009169	R434	R-CHIP	SA
2007-009171	R311	R-CHIP	SA
2007-009171	R312	R-CHIP	SA
2007-009171	R313	R-CHIP	SA
2007-009171	R314	R-CHIP	SA
2007-009171	R315	R-CHIP	SA
2007-009171	R416	R-CHIP	SA
2007-009171	R418	R-CHIP	SA
2007-009208	R510	R-CHIP	SA
2007-009208	R513	R-CHIP	SA
2007-009408	R436	R-CHIP	SA
2007-009410	R433	R-CHIP	SA
2007-009801	R205	R-CHIP	SA
2203-000138	C419	C-CER,CHIP	SA
2203-000254	C205	C-CER,CHIP	SA
2203-000254	C322	C-CER,CHIP	SA
2203-000254	C519	C-CER,CHIP	SA
2203-000254	C520	C-CER,CHIP	SA
2203-000278	C117	C-CER,CHIP	SA
2203-000330	C100	C-CER,CHIP	SA
2203-000330	C201	C-CER,CHIP	SA
2203-000438	C121	C-CER,CHIP	SA
2203-000438	C122	C-CER,CHIP	SA
2203-000438	C126	C-CER,CHIP	SA
2203-000438	C315	C-CER,CHIP	SA

SEC CODE	Design LOC	Discription	STATUS
2203-000438	C316	C-CER,CHIP	SA
2203-000438	C326	C-CER,CHIP	SA
2203-000438	C329	C-CER,CHIP	SA
2203-000438	C522	C-CER,CHIP	SA
2203-000438	C527	C-CER,CHIP	SA
2203-000466	C133	C-CER,CHIP	SA
2203-000696	C113	C-CER,CHIP	SA
2203-000812	C112	C-CER,CHIP	SA
2203-000812	C127	C-CER,CHIP	SA
2203-000812	C200	C-CER,CHIP	SA
2203-000812	C504	C-CER,CHIP	SA
2203-000812	C505	C-CER,CHIP	SA
2203-000812	C523	C-CER,CHIP	SA
2203-000812	C524	C-CER,CHIP	SA
2203-000836	C245	C-CER,CHIP	SA
2203-000854	C111	C-CER,CHIP	SA
2203-000995	C105	C-CER,CHIP	SA
2203-000995	C119	C-CER,CHIP	SA
2203-000995	C120	C-CER,CHIP	SA
2203-000995	C454	C-CER,CHIP	SA
2203-002668	C208	C-CER,CHIP	SA
2203-002677	C204	C-CER,CHIP	SA
2203-002709	C116	C-CER,CHIP	SA
2203-002709	C130	C-CER,CHIP	SA
2203-002709	C700	C-CER,CHIP	SA
2203-002709	C701	C-CER,CHIP	SA
2203-005390	C101	C-CER,CHIP	SA
2203-005450	C207	C-CER,CHIP	SA
2203-005482	C500	C-CER,CHIP	SA
2203-005482	C518	C-CER,CHIP	SA
2203-005482	C601	C-CER,CHIP	SA
2203-005682	C109	C-CER,CHIP	SA
2203-005682	C110	C-CER,CHIP	SA
2203-005682	C231	C-CER,CHIP	SA
2203-005682	C440	C-CER,CHIP	SA
2203-005682	C441	C-CER,CHIP	SA

SEC CODE	Design LOC	Discription	STATUS
2203-005682	C442	C-CER,CHIP	SA
2203-005682	C443	C-CER,CHIP	SA
2203-005682	C444	C-CER,CHIP	SA
2203-005682	C445	C-CER,CHIP	SA
2203-005682	C446	C-CER,CHIP	SA
2203-005682	C447	C-CER,CHIP	SA
2203-005682	C450	C-CER,CHIP	SA
2203-005682	C451	C-CER,CHIP	SA
2203-005682	C512	C-CER,CHIP	SA
2203-005682	C513	C-CER,CHIP	SA
2203-005682	C702	C-CER,CHIP	SA
2203-005682	C706	C-CER,CHIP	SA
2203-005683	C220	C-CER,CHIP	SA
2203-005683	C221	C-CER,CHIP	SA
2203-005683	C355	C-CER,CHIP	SA
2203-005683	C514	C-CER,CHIP	SA
2203-005683	C515	C-CER,CHIP	SA
2203-005683	C708	C-CER,CHIP	SA
2203-005683	C709	C-CER,CHIP	SA
2203-005683	C710	C-CER,CHIP	SA
2203-005683	C711	C-CER,CHIP	SA
2203-005683	C712	C-CER,CHIP	SA
2203-005683	C713	C-CER,CHIP	SA
2203-005683	C714	C-CER,CHIP	SA
2203-005725	C211	C-CER,CHIP	SA
2203-005725	C212	C-CER,CHIP	SA
2203-005725	C225	C-CER,CHIP	SA
2203-005725	C226	C-CER,CHIP	SA
2203-005725	C232	C-CER,CHIP	SA
2203-005725	C235	C-CER,CHIP	SA
2203-005725	C237	C-CER,CHIP	SA
2203-005725	C238	C-CER,CHIP	SA
2203-005725	C241	C-CER,CHIP	SA
2203-005725	C242	C-CER,CHIP	SA
2203-005725	C255	C-CER,CHIP	SA
2203-005727	C218	C-CER,CHIP	SA

SEC CODE	Design LOC	Discription	STATUS
2203-005731	C411	C-CER,CHIP	SA
2203-005731	C412	C-CER,CHIP	SA
2203-005736	C106	C-CER,CHIP	SA
2203-005736	C108	C-CER,CHIP	SA
2203-005736	C210	C-CER,CHIP	SA
2203-005736	C227	C-CER,CHIP	SA
2203-005736	C243	C-CER,CHIP	SA
2203-005736	C252	C-CER,CHIP	SA
2203-005736	C256	C-CER,CHIP	SA
2203-005736	C408	C-CER,CHIP	SA
2203-005736	C409	C-CER,CHIP	SA
2203-005736	C521	C-CER,CHIP	SA
2203-005742	C219	C-CER,CHIP	SA
2203-005777	C253	C-CER,CHIP	SA
2203-005806	C248	C-CER,CHIP	SNA
2203-005806	C251	C-CER,CHIP	SNA
2203-005806	C430	C-CER,CHIP	SNA
2203-005806	C437	C-CER,CHIP	SNA
2203-005808	C254	C-CER,CHIP	SA
2203-006048	C104	C-CER,CHIP	SA
2203-006048	C308	C-CER,CHIP	SA
2203-006048	C431	C-CER,CHIP	SA
2203-006120	C213	C-CER,CHIP	SA
2203-006120	C214	C-CER,CHIP	SA
2203-006120	C216	C-CER,CHIP	SA
2203-006120	C217	C-CER,CHIP	SA
2203-006194	C128	C-CER,CHIP	SA
2203-006194	C224	C-CER,CHIP	SA
2203-006194	C306	C-CER,CHIP	SA
2203-006194	C318	C-CER,CHIP	SA
2203-006194	C320	C-CER,CHIP	SA
2203-006194	C327	C-CER,CHIP	SA
2203-006194	C330	C-CER,CHIP	SA
2203-006194	C332	C-CER,CHIP	SA
2203-006194	C334	C-CER,CHIP	SA
2203-006194	C336	C-CER,CHIP	SA



SEC CODE	Design LOC	Discription	STATUS
2203-006194	C338	C-CER,CHIP	SA
2203-006194	C339	C-CER,CHIP	SA
2203-006194	C343	C-CER,CHIP	SA
2203-006194	C345	C-CER,CHIP	SA
2203-006194	C347	C-CER,CHIP	SA
2203-006194	C452	C-CER,CHIP	SA
2203-006261	C102	C-CER,CHIP	SA
2203-006305	C107	C-CER,CHIP	SA
2203-006305	C131	C-CER,CHIP	SA
2203-006305	C422	C-CER,CHIP	SA
2203-006305	C426	C-CER,CHIP	SA
2203-006305	C428	C-CER,CHIP	SA
2203-006305	C429	C-CER,CHIP	SA
2203-006307	C606	C-CER,CHIP	SA
2203-006324	C206	C-CER,CHIP	SA
2203-006399	C115	C-CER,CHIP	SA
2203-006399	C129	C-CER,CHIP	SA
2203-006399	C132	C-CER,CHIP	SA
2203-006399	C324	C-CER,CHIP	SA
2203-006399	C325	C-CER,CHIP	SA
2203-006423	C125	C-CER,CHIP	SA
2203-006423	C209	C-CER,CHIP	SA
2203-006423	C222	C-CER,CHIP	SA
2203-006423	C233	C-CER,CHIP	SA
2203-006423	C234	C-CER,CHIP	SA
2203-006423	C236	C-CER,CHIP	SA
2203-006423	C239	C-CER,CHIP	SA
2203-006423	C244	C-CER,CHIP	SA
2203-006423	C246	C-CER,CHIP	SA
2203-006423	C247	C-CER,CHIP	SA
2203-006423	C249	C-CER,CHIP	SA
2203-006423	C250	C-CER,CHIP	SA
2203-006423	C304	C-CER,CHIP	SA
2203-006423	C305	C-CER,CHIP	SA
2203-006423	C307	C-CER,CHIP	SA
2203-006423	C309	C-CER,CHIP	SA

SEC CODE	Design LOC	Discription	STATUS
2203-006423	C310	C-CER,CHIP	SA
2203-006423	C311	C-CER,CHIP	SA
2203-006423	C312	C-CER,CHIP	SA
2203-006423	C313	C-CER,CHIP	SA
2203-006423	C314	C-CER,CHIP	SA
2203-006423	C317	C-CER,CHIP	SA
2203-006423	C319	C-CER,CHIP	SA
2203-006423	C321	C-CER,CHIP	SA
2203-006423	C323	C-CER,CHIP	SA
2203-006423	C328	C-CER,CHIP	SA
2203-006423	C331	C-CER,CHIP	SA
2203-006423	C333	C-CER,CHIP	SA
2203-006423	C335	C-CER,CHIP	SA
2203-006423	C337	C-CER,CHIP	SA
2203-006423	C340	C-CER,CHIP	SA
2203-006423	C341	C-CER,CHIP	SA
2203-006423	C342	C-CER,CHIP	SA
2203-006423	C344	C-CER,CHIP	SA
2203-006423	C346	C-CER,CHIP	SA
2203-006423	C348	C-CER,CHIP	SA
2203-006423	C349	C-CER,CHIP	SA
2203-006423	C350	C-CER,CHIP	SA
2203-006423	C351	C-CER,CHIP	SA
2203-006423	C352	C-CER,CHIP	SA
2203-006423	C354	C-CER,CHIP	SA
2203-006423	C404	C-CER,CHIP	SA
2203-006423	C407	C-CER,CHIP	SA
2203-006423	C410	C-CER,CHIP	SA
2203-006423	C449	C-CER,CHIP	SA
2203-006423	C716	C-CER,CHIP	SA
2203-006423	C717	C-CER,CHIP	SA
2203-006423	C719	C-CER,CHIP	SA
2203-006423	C721	C-CER,CHIP	SA
2203-006439	C229	C-CER,CHIP	SNA
2203-006439	C230	C-CER,CHIP	SNA
2203-006462	C301	C-CER,CHIP	SA

SEC CODE	Design LOC	Discription	STATUS
2203-006556	C356	C-CER,CHIP	SA
2203-006556	C508	C-CER,CHIP	SA
2203-006556	C509	C-CER,CHIP	SA
2203-006562	C123	C-CER,CHIP	SA
2203-006562	C124	C-CER,CHIP	SA
2203-006562	C438	C-CER,CHIP	SA
2203-006562	C448	C-CER,CHIP	SA
2203-006562	C455	C-CER,CHIP	SA
2203-006562	C502	C-CER,CHIP	SA
2203-006562	C506	C-CER,CHIP	SA
2203-006562	C602	C-CER,CHIP	SA
2203-006562	C603	C-CER,CHIP	SA
2203-006562	C604	C-CER,CHIP	SA
2203-006562	C605	C-CER,CHIP	SA
2203-006562	C607	C-CER,CHIP	SA
2203-006562	C609	C-CER,CHIP	SA
2203-006562	C612	C-CER,CHIP	SA
2203-006562	C614	C-CER,CHIP	SA
2203-006562	C615	C-CER,CHIP	SA
2203-006562	C616	C-CER,CHIP	SA
2203-006562	C618	C-CER,CHIP	SA
2203-006562	C620	C-CER,CHIP	SA
2203-006562	C715	C-CER,CHIP	SA
2203-006562	C718	C-CER,CHIP	SA
2203-006562	C720	C-CER,CHIP	SA
2203-006562	C723	C-CER,CHIP	SA
2203-006648	C302	C-CER,CHIP	SA
2203-006648	C303	C-CER,CHIP	SA
2203-006648	C501	C-CER,CHIP	SA
2203-006648	C503	C-CER,CHIP	SA
2203-006668	C300	C-CER,CHIP	SA
2203-006681	C406	C-CER,CHIP	SA
2203-006712	C421	C-CER,CHIP	SA
2203-006824	C413	C-CER,CHIP	SA
2203-006824	C418	C-CER,CHIP	SA
2203-006824	C420	C-CER,CHIP	SA

SEC CODE	Design LOC	Discription	STATUS
2203-006824	C423	C-CER,CHIP	SA
2203-006824	C427	C-CER,CHIP	SA
2203-006824	C435	C-CER,CHIP	SA
2203-006824	C436	C-CER,CHIP	SA
2203-006824	C600	C-CER,CHIP	SA
2203-006825	C223	C-CER,CHIP	SA
2203-006825	C228	C-CER,CHIP	SA
2203-006825	C402	C-CER,CHIP	SA
2203-006825	C403	C-CER,CHIP	SA
2203-006838	C215	C-CER,CHIP	SA
2203-006838	C405	C-CER,CHIP	SA
2203-006838	C414	C-CER,CHIP	SA
2203-006838	C415	C-CER,CHIP	SA
2203-006838	C416	C-CER,CHIP	SA
2203-006838	C424	C-CER,CHIP	SA
2203-006838	C453	C-CER,CHIP	SA
2203-006838	C610	C-CER,CHIP	SA
2203-006838	C611	C-CER,CHIP	SA
2203-006838	C613	C-CER,CHIP	SA
2203-006838	C617	C-CER,CHIP	SA
2203-006838	C619	C-CER,CHIP	SA
2203-006838	C722	C-CER,CHIP	SA
2203-006839	C118	C-CER,CHIP	SA
2203-006839	C432	C-CER,CHIP	SA
2203-006839	C433	C-CER,CHIP	SA
2203-006839	C434	C-CER,CHIP	SA
2203-006839	C724	C-CER,CHIP	SA
2203-006841	C400	C-CER,CHIP	SA
2203-006841	C401	C-CER,CHIP	SA
2203-006841	C417	C-CER,CHIP	SA
2203-006841	C439	C-CER,CHIP	SA
2203-006841	C516	C-CER,CHIP	SA
2203-006841	C517	C-CER,CHIP	SA
2203-006872	C425	C-CER,CHIP	SA
2203-006872	C507	C-CER,CHIP	SA
2203-006994	C240	C-CER,CHIP	SA

SEC CODE	Design LOC	Discription	STATUS
2404-001377	TA500	C-TA,CHIP	SA
2404-001381	TA200	C-TA,CHIP	SA
2404-001411	TA400	C-TA,CHIP	SA
2404-001415	TA600	C-TA,CHIP	SA
2404-001415	TA601	C-TA,CHIP	SA
2404-001424	TA501	C-TA,CHIP	SA
2404-001474	TA100	C-TA,CHIP	SA
2703-001737	L200	INDUCTOR-SMD	SA
2703-002155	L102	INDUCTOR-SMD	SA
2703-002199	L101	INDUCTOR-SMD	SA
2703-002208	L100	INDUCTOR-SMD	SA
2703-002309	L504	INDUCTOR-SMD	SA
2703-002309	L506	INDUCTOR-SMD	SA
2703-002313	L116	INDUCTOR-SMD	SA
2703-002313	L500	INDUCTOR-SMD	SA
2703-002313	L502	INDUCTOR-SMD	SA
2703-002782	L400	INDUCTOR-SMD	SA
2703-002782	L401	INDUCTOR-SMD	SA
2703-002782	L402	INDUCTOR-SMD	SA
2703-002793	L205	INDUCTOR-SMD	SA
2703-002795	L112	INDUCTOR-SMD	SNA
2703-002795	L114	INDUCTOR-SMD	SNA
2703-002901	L108	INDUCTOR-SMD	SNA
2703-002907	L103	INDUCTOR-SMD	SNA
2703-002907	L106	INDUCTOR-SMD	SNA
2703-002907	L107	INDUCTOR-SMD	SNA
2703-002907	L110	INDUCTOR-SMD	SNA
2703-002917	L202	INDUCTOR-SMD	SA
2703-002917	L203	INDUCTOR-SMD	SA
2703-002917	L204	INDUCTOR-SMD	SA
2703-002917	L206	INDUCTOR-SMD	SA
2703-002953	L104	INDUCTOR-SMD	SA
2703-002955	L105	INDUCTOR-SMD	SA
2703-002955	L109	INDUCTOR-SMD	SA
2703-002961	L501	INDUCTOR-SMD	SA
2703-002961	L503	INDUCTOR-SMD	SA

SEC CODE	Design LOC	Discription	STATUS
2703-002961	L508	INDUCTOR-SMD	SA
2703-002961	L509	INDUCTOR-SMD	SA
2703-003004	L111	INDUCTOR-SMD	SA
2703-003004	L113	INDUCTOR-SMD	SA
2703-003196	L600	INDUCTOR-SMD	SA
2703-003249	L115	INDUCTOR-SMD	SA
2801-004373	OSC400	CRYSTAL-SMD	SA
2809-001280	TCXO100	OSCILLATOR-VCTCXO	SA
2901-001351	F704	FILTER-EMI/ESD	SA
2901-001351	F705	FILTER-EMI/ESD	SA
2901-001408	F700	FILTER-EMI SMD	SA
2901-001408	F701	FILTER-EMI SMD	SA
2901-001408	F702	FILTER-EMI SMD	SA
2901-001408	F703	FILTER-EMI SMD	SA
2904-001658	F200	FILTER-SAW	SA
2904-001702	F202	FILTER-SAW	SA
2904-001703	F101	FILTER-SAW	SA
2904-001812	F100	FILTER-SAW	SA
2909-001279	F102	FILTER-LC	SA
2910-000031	DUP200	DUPLEXER-SAW	SA
3301-001208	L505	BEAD-SMD	SA
3301-001208	L507	BEAD-SMD	SA
3301-001534	L403	BEAD-SMD	SA
3301-001659	L117	BEAD-SMD	SA
3301-001729	L601	BEAD-SMD	SA
3404-001303	SWT_KEY	SWITCH-TACT	SA
3404-001303	VOL_DOWN	SWITCH-TACT	SA
3404-001303	VOL_UP	SWITCH-TACT	SA
3404-001303	VT_KEY	SWITCH-TACT	SA
3705-001358	RFS100	CONNECTOR-COAXIAL	SA
3708-001890	HEA700	CONNECTOR-FPC/FFC/PIC	SA
3709-001453	CN400	CONNECTOR-CARD EDGE	SA
3710-002523	IFC600	SOCKET-INTERFACE	SA
3711-006256	BTC400	HEADER-BATTERY	SA
3711-006630	HEA701	HEADER-BOARD TO BOARD	SA
3711-006630	HEA702	HEADER-BOARD TO BOARD	SA

SEC CODE	Design LOC	Discription	STATUS
4302-001180	BAT400	BATTERY-LI(2ND)	SA
4709-001399	F201	COUPLER-DIRECTION	SA
GH70-02640A	CLIP300	ICT SHIELD-CAN CLIP	SA
GH70-02640A	CLIP302	ICT SHIELD-CAN CLIP	SA
GH70-02640A	CLIP303	ICT SHIELD-CAN CLIP	SA
GH70-02640A	CLIP304	ICT SHIELD-CAN CLIP	SA
GH70-02640A	CLIP306	ICT SHIELD-CAN CLIP	SA
GH70-02640A	CLIP307	ICT SHIELD-CAN CLIP	SA
GH70-02640A	CLIP308	ICT SHIELD-CAN CLIP	SA
GH70-02640A	CLIP309	ICT SHIELD-CAN CLIP	SA
GH70-02640A	CLIP310	ICT SHIELD-CAN CLIP	SA
GH70-02640A	CLIP311	ICT SHIELD-CAN CLIP	SA
GH70-02640A	CLIP312	ICT SHIELD-CAN CLIP	SA
GH70-02640A	CLIP313	ICT SHIELD-CAN CLIP	SA
GH70-02640A	CLIP315	ICT SHIELD-CAN CLIP	SA
GH70-02640A	CLIP316	ICT SHIELD-CAN CLIP	SA
GH70-02640A	CLIP317	ICT SHIELD-CAN CLIP	SA
GH70-02640A	CLIP318	ICT SHIELD-CAN CLIP	SA
GH70-02640A	CLIP319	ICT SHIELD-CAN CLIP	SA
GH70-02640A	CLIP320	ICT SHIELD-CAN CLIP	SA

Please consult the GSPN website (Samsung Portal) for the most recent version of the product's part list.