

SAMSUNG

GSM TELEPHONE

SGH-L600

SERVICE *Manual*

GSM TELEPHONE



CONTENTS

1. Safety Precautions
2. Specification
3. Product Function
4. Array course control
5. Exploded View and Part List
6. MAIN Electrical Parts List
7. Block Diagrams
8. PCB Diagrams
9. Flow Chart of Troubleshooting
10. Reference data
11. Disassembly and Assembly Instructions

**SAMSUNG
ELECTRONICS**



GSPN (Global Service Partner Network)

Country	Web Site
North America	service.samsungportal.com
Latin America	latin.samsungportal.com
CIS	cis.samsungportal.com
Europe	europe.samsungportal.com
China	china.samsungportal.com
Asia	asia.samsungportal.com
Mideast & Africa	mea.samsungportal.com

2. Specification

2-1. GSM General Specification

	GSM900 Phase 1	EGSM 900 Phase 2	DCS1800 Phase 1	PCS1900
Freq. Band[MHz] Uplink/Downlink	890~915 935~960	880~915 925~960	1710~1785 1805~1880	1850~1910 1930~1990
ARFCN range	1~124	0~124 & 975~1023	512~885	512~810
Tx/Rx spacing	45MHz	45MHz	95MHz	80MHz
Mod. Bit rate / Bit Period	270.833kbps 3.692us	270.833kbps 3.692us	270.833kbps 3.692us	270.833kbps 3.692us
Time Slot Period / Frame Period	576.9us 4.615ms	576.9us 4.615ms	576.9us 4.615ms	576.9us 4.615ms
Modulation	0.3GMSK	0.3GMSK	0.3GMSK	0.3GMSK
MS Power	33dBm~5dBm	33dBm~5dBm	30dBm~0dBm	30dBm~0dBm
Power Class	5pcl ~ 19pcl	5pcl ~ 19pcl	0pcl ~ 15pcl	0pcl ~ 15pcl
Sensitivity	-102dBm	-102dBm	-100dBm	-100dBm
TDMA Mux	8	8	8	8
Cell Radius	35Km	35Km	2Km	-

2-2. GSM TX power class

TX Power control level	GSM900
5	33±2 dBm
6	31±3 dBm
7	29±3 dBm
8	27±3 dBm
9	25±3 dBm
10	23±3 dBm
11	21±3 dBm
12	19±3 dBm
13	17±3 dBm
14	15±3 dBm
15	13±3 dBm
16	11±5 dBm
17	9±5 dBm
18	7±5 dBm
19	5±5 dBm

TX Power control level	DCS1800
0	30±2 dBm
1	28±3 dBm
2	26±3 dBm
3	24±3 dBm
4	22±3 dBm
5	20±3 dBm
6	18±3 dBm
7	16±3 dBm
8	14±3 dBm
9	12±4 dBm
10	10±4 dBm
11	8±4dBm
12	6±4 dBm
13	4±4 dBm
14	2±5 dBm
15	0±5 dBm

TX Power control level	PCS1900
0	30±2 dBm
1	28±3 dBm
2	26±3 dBm
3	24±3 dBm
4	22±3 dBm
5	20±3 dBm
6	18±3 dBm
7	16±3 dBm
8	14±3 dBm
9	12±4 dBm
10	10±4 dBm
11	8±4dBm
12	6±4 dBm
13	4±4 dBm
14	2±5 dBm
15	0±5 dBm

2-3. GSM EDGE TX power class

TX Power control level	GSM900	TX Power control level	DCS1800	TX Power control level	PCS1900
8	27±3 dBm	2	26 -4/+3 dBm	2	26 -4/+3 dBm
9	25±3 dBm	3	24±3 dBm	3	24±3 dBm
10	23±3 dBm	4	22±3 dBm	4	22±3 dBm
11	21±3 dBm	5	20±3 dBm	5	20±3 dBm
12	19±3 dBm	6	18±3 dBm	6	18±3 dBm
13	17±3 dBm	7	16±3 dBm	7	16±3 dBm
14	15±3 dBm	8	12±3 dBm	8	12±3 dBm
15	13±3 dBm	9	10±3 dBm	9	10±3 dBm
16	11±5 dBm	10	14±3 dBm	10	14±3 dBm
17	9±5 dBm	11	12±4 dBm	11	12±4 dBm
18	7±5 dBm	12	10±4 dBm	12	10±4 dBm
19	5±5 dBm	13	8±4dBm	13	8±4dBm
		14	6±4 dBm	14	6±4 dBm
		15	4±4 dBm	15	4±4 dBm

5. Exploded View and Parts List

5-1. Cellular phone Exploded View

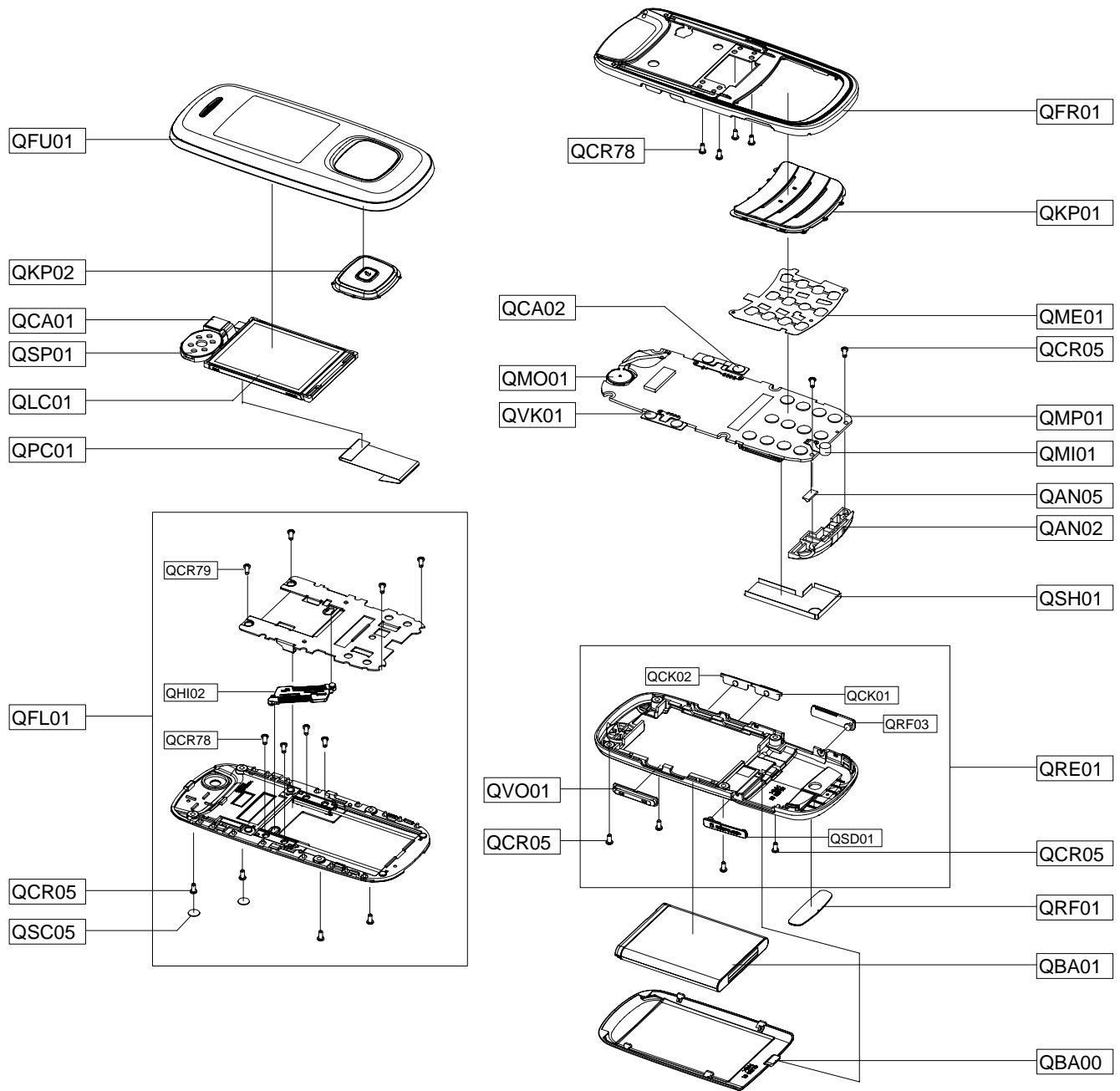

5-2. Cellular phone Parts List

Design LOC	Description	SEC CODE
QAN02	ANTENNA-SGHL600	GH42-01289A
QAN05	ASSY MEC-ANTENNA CONTACT	GH75-08168A
QBA00	ASSY COVER-BATT	GH98-05995A
QBA01	INNER BATTERY PACK-800MAH,BLK,	GH43-02719A
QCA01	CAMERA MODULE	GH59-04587A
QCA02	KEY FPCB-CAMERA KEY	GH59-04685A
QCK01	PMO KEY-CAMERA V2	GH72-42130A
QCK02	PMO KEY-POWER	GH72-42131A
QCR05	SCREW-MACHINE	6001-001478
QCR05	SCREW-MACHINE	6001-001478
QCR05	SCREW-MACHINE	6001-001478
QCR05	SCREW-MACHINE	6001-001478
QCR78	SCREW-MACHINE	6001-002116
QCR78	SCREW-MACHINE	6001-002116
QCR79	SCREW-SPECIAL	6009-001534
QFL01	ASSY CASE-SLIDE LOWER	GH98-04778A
QFR01	ASSY CASE-FRONT	GH98-04776A
QFU01	ASSY CASE-SLIDE UPPER	GH98-04779A
QHI02	ASSY HINGE-ACTUATOR BODY	GH98-05288A
QKP01	ASSY KEYPAD-MAIN(OPEN/VIO)	GH98-04780A
QKP02	ASSY KEYPAD-SUB(OPEN/VIO)	GH98-04781A
QLC01	LCD-SGHL600	GH07-01143A
QME01	DOME SHEET-DOME SHEET 12KEY	GH59-04702A
QMI01	MICROPHONE-ASSY	GH30-00397A
QMO01	MOTOR DC-SGHL600	GH31-00347A
QMP01	PBA MAIN-SGHL600	GH92-03830A
QPC01	MEA-FPCBKIT	GH97-08187A
QRE01	ASSY CASE-REAR	GH98-04777A
QRF01	PMO-COVER RF	GH72-39632A
QRF03	PMO-COVER EARPHONE	GH72-39628A
QSC05	TAPE-LOWER SCREW CAP	GH74-33615A
QSD01	PMO-COVER SD	GH72-39627A
QSH01	ICT-COVER SHIELD	GH70-02406A
QSP01	MICRO SPEAKER	3001-002196
QVK01	KEY FPCB-VOLUME KEY	GH59-04687A
QVO01	PMO-VOLUME KEY	GH72-39629A

Description	SEC CODE
ADAPTOR-ATADS10ESE,SIL,EU	GH44-01702B
EARPHONE-20P,SIL,B-TYPE,FM	GH59-05108A
PCB-SGH-L600	GH41-01762A
LABEL(R)-WATER SOAK	GH68-09361A
TAPE-LED BLACK	GH74-33618A
UNIT-SUBPBA	GH59-04690A
TAPE INSU	GH74-33638A
TAPE-SUB FPCB 1	GH74-35597A
TAPE-LCD	GH74-35598A
SPONGE-SLIDE FPCB	GH74-35601A
SPONGE-SUB FPCB 2	GH74-35636A
TAPE INSU-SUB FPCB CON	GH74-35637A
TAPE INSU-LCD BOTTOM	GH74-35638A
TAPE GASK-SUB PBA	GH74-35889A
MANUAL USERS-EU FRENCH	GH68-15731A
BAG PE	6902-000634
LABEL(P)-UNIT SEAL	GH68-00518B
LABEL(P)-OPEN MP3	GH68-11246A
LABEL(R)-MAIN(XEF)	GH68-15795B
BOX-UNIT(EU)	GH69-05804B
CUSHION-CASE(EU)	GH69-05805A
VINYL-BOHO UPPER COVER	GH74-35791A

11. Disassembly and Assembly Instructions

11-1. Disassembly Instructions

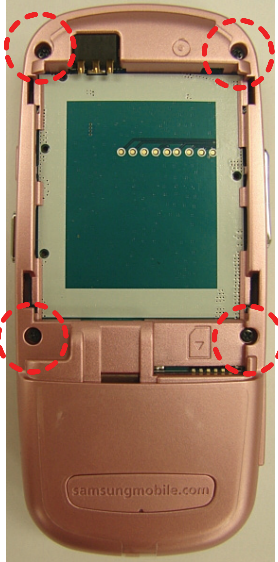
<div data-bbox="170 310 251 367" style="border: 1px solid black; padding: 2px; width: fit-content;">1</div> 	<div data-bbox="836 310 917 367" style="border: 1px solid black; padding: 2px; width: fit-content;">2</div>  <div data-bbox="857 909 1432 955" style="border: 1px solid black; padding: 2px;">1) Remove 4 screws of the Rear</div>
<p>1) Remove the Battery and SIM card.</p>	<p>1) Don't scratch the surface of the handset. Please pay attention.</p>
<div data-bbox="170 1176 251 1232" style="border: 1px solid black; padding: 2px; width: fit-content;">3</div>  <div data-bbox="240 1675 722 1759" style="border: 1px solid black; padding: 2px;">1) Separate the Rear and the Front with holding top of the Rear.</div>	<div data-bbox="836 1176 917 1232" style="border: 1px solid black; padding: 2px; width: fit-content;">4</div>  <div data-bbox="1198 1558 1464 1759" style="border: 1px solid black; padding: 2px;">1) Separate the center hook and side both hooks with holding the bottom of the Rear</div>
<p>1) Don't devote heavily the top of the Rear.</p>	<p>1) Be careful to break the center and both side Hooks.</p>

5

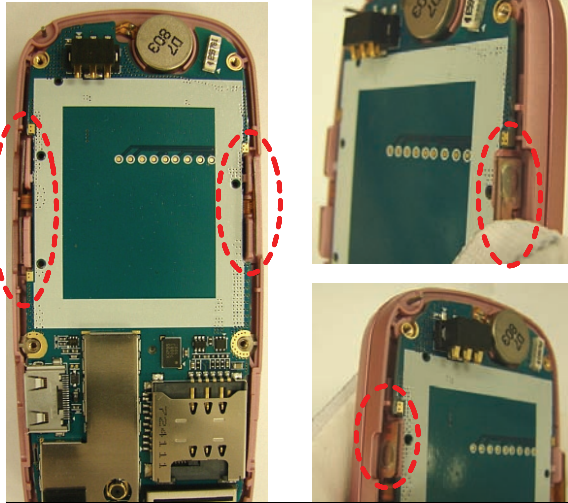

- 1) Take off the Camera Key-FPCB from the Front
- 2) Take off the Volume Key-FPCB from the Front

1) Be careful to damage the FPCB.

6

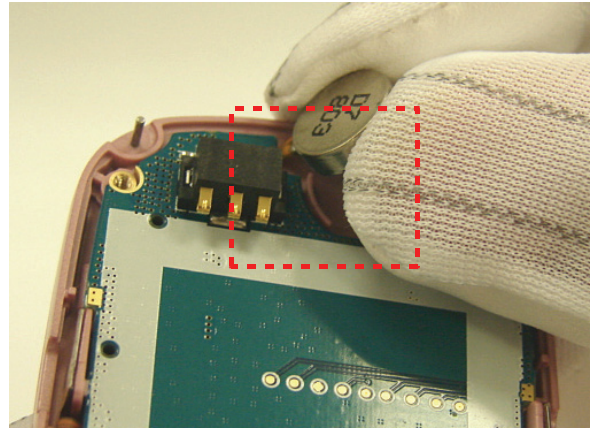

- 1) Take off the Vibrator-FPCB from the Front.

1) Be careful to damage the FPCB.

7

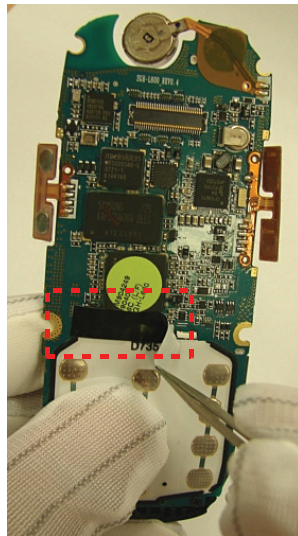
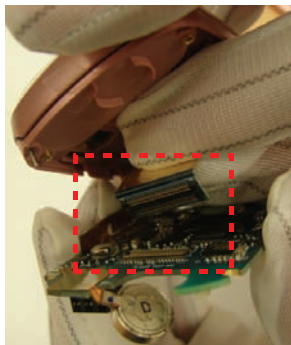

- 1) Separate Slide-FPCB and the Main PBA.
- 2) Take off the shading tape from the PBA.

1) Be careful to damage the SLIDE FPCB.
2) Be careful to damage the DOME SHEET.

8

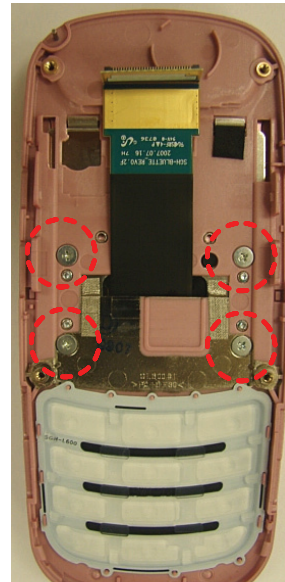

- 1) Remove 4 screws of the Front.

1) Don't scratch the surface of the handset.
Please pay attention.

9

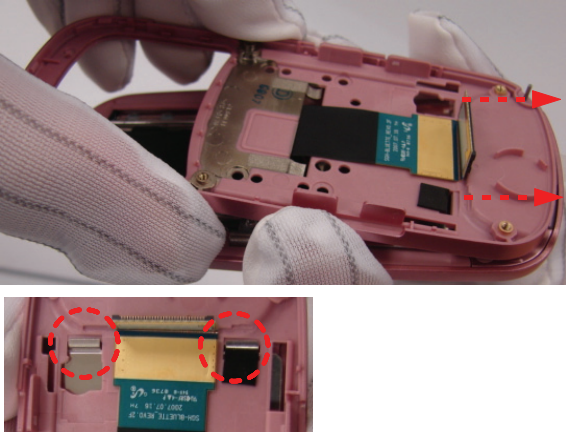

1) Separate the Front and Lower with pushing the Front ahead.

1) Be careful to damage the Hooks of the Front.

10

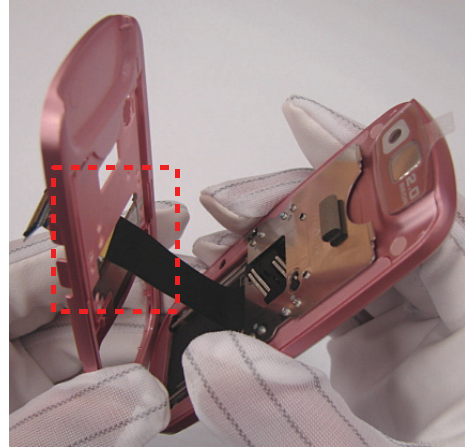

1) Separate the Front and Lower with closing the Side.

1) Be careful to damage the S-FPCB
2) Pass through the S-FPCB with closing the Slide.

11

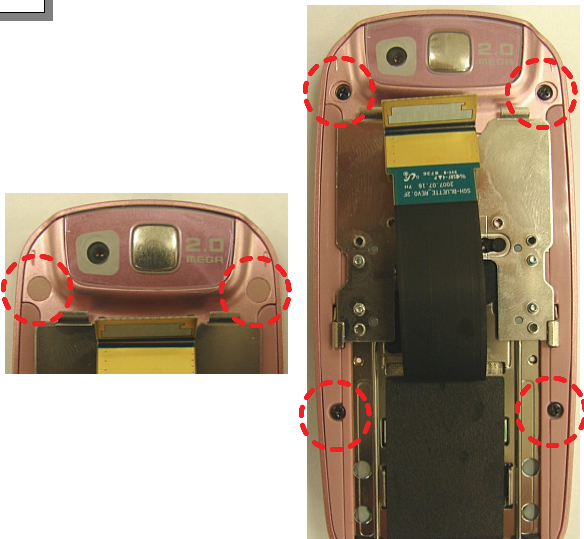

1) Remove the Screw caps.
2) Remove 4 point screws of the Lower

1) Don't scratch the surface of the handset.
Please pay attention.

12

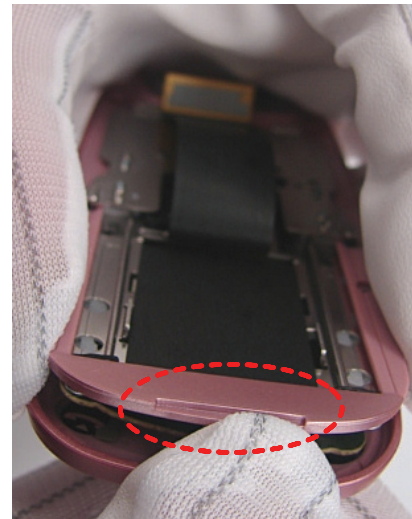

1) Separate the Lower and Upper with pushing the bottom of the Upper.

1) Don't scratch the surface of the handset.
Please pay attention.

13

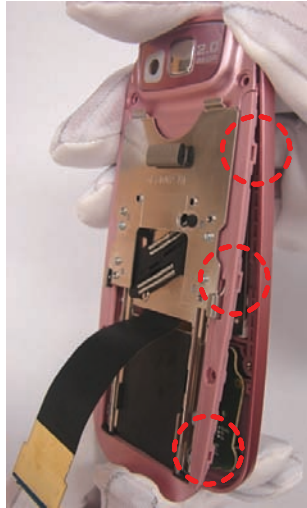

1) Separate the Lower and Upper from the side of Upper and top of the Hook.

1) Don't scratch the surface of the handset. Please pay attention.

14

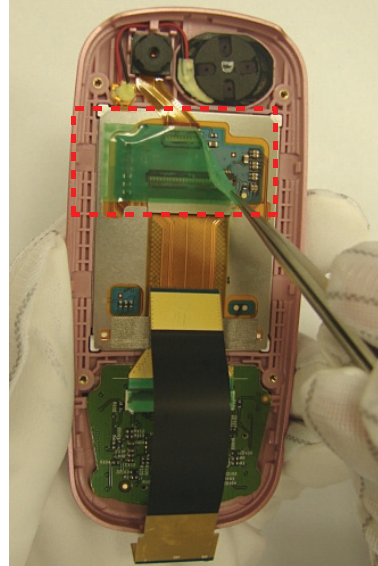

1) Remove the insulating tape from the LCD Connector.

1) Be careful to damage the Sub PCB-FPCB.

15

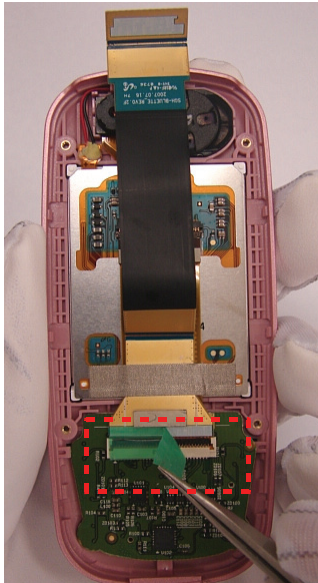

1) Remove the insulating tape from the Sub PCB Connector.

1) Be careful to damage the Sub PCB Connector.

16

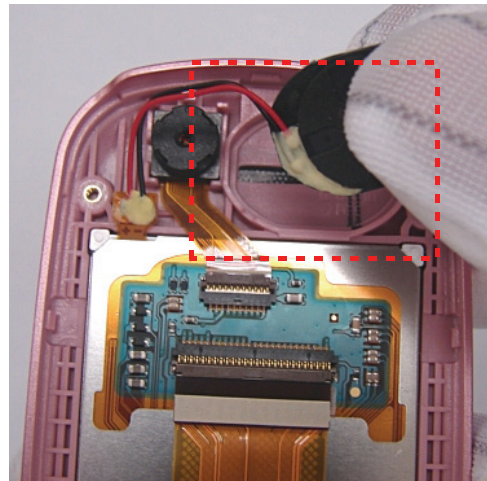

1) Separate the Speaker from the Upper.

1) Be careful to damage the Speaker and wire.

17

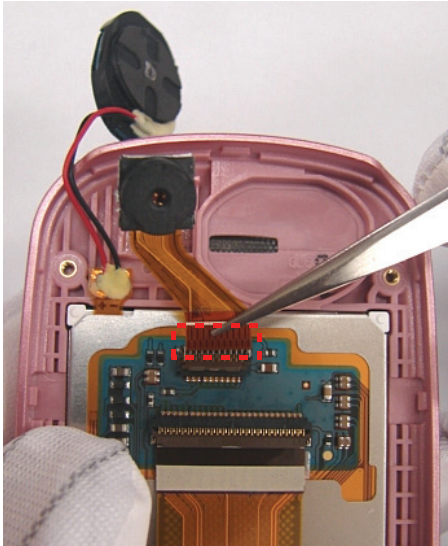

- 1) Separate the Camera from the Upper .
- 2) Separate the Camera-FPCB from connector with opening the Actuator .

1) Be careful to damage the Camera and FPCB.

18

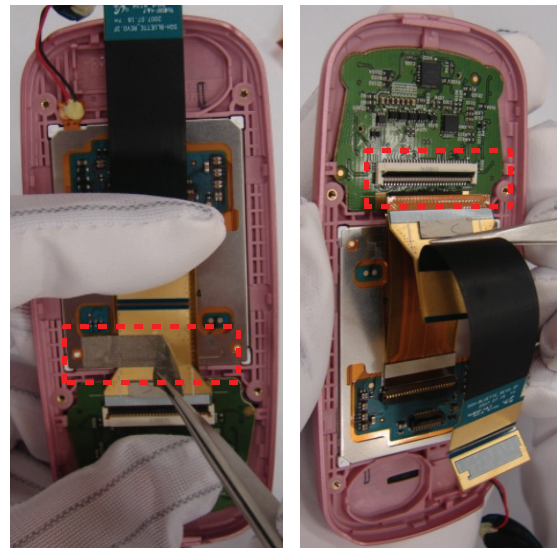

- 1) Separate the Conductive tape from the LCD.
- 2) Separate the S-FPCB from connector with opening the Actuator .

1) Be careful to damage the S-FPCB.

19

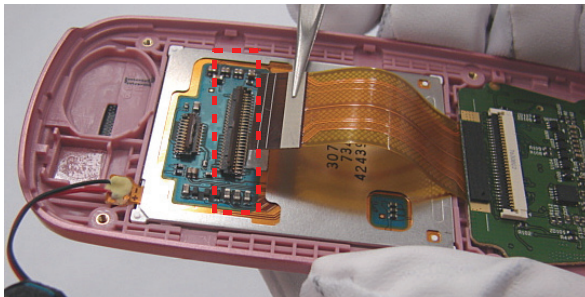

- 1) Separate the Sub PCB-FPCB from connector with opening the Actuator

1) Be careful to damage the Sub PCB-FPCB.

20



- 1) Separate Sub PBA andL LCD from Upper

1)Be careful to damage the Sub PCB and S-FPCB

11-2. Assembly Instructions

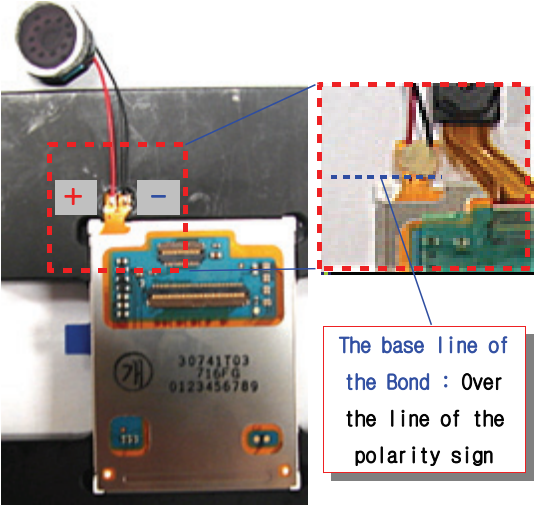
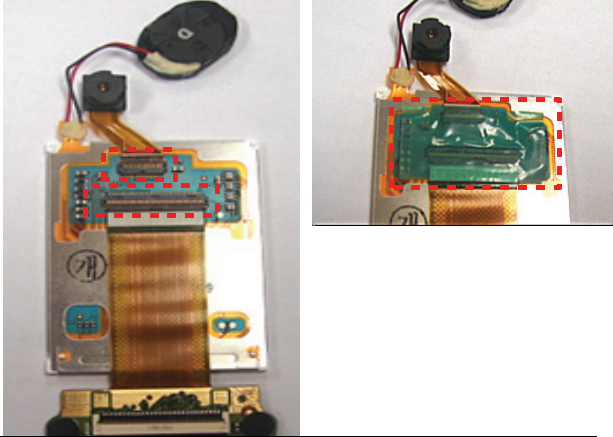
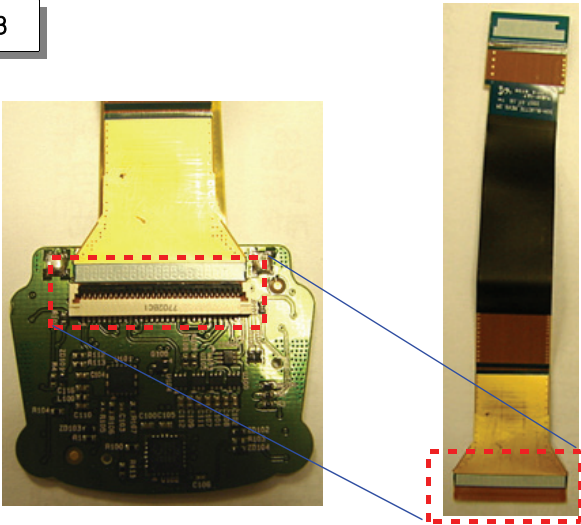
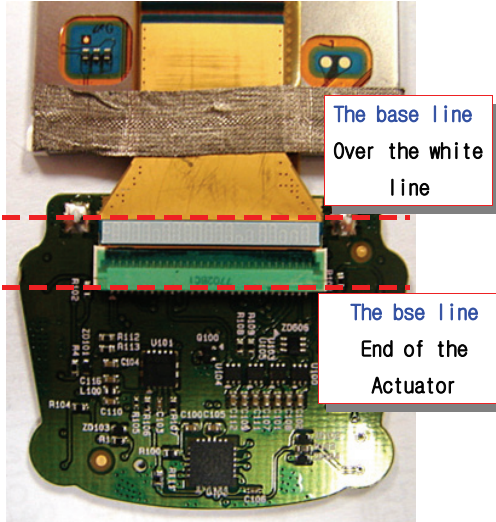
<p>1</p>  <p>1) Solder the wire of the Speaker and Bond it.</p>	<p>2</p>  <p>1) Insert the Camera FPCB to the small Actuator. 2) Insert the SUB Pba-FPCB to the other Actuator. 3) Attach the Insulating tape on the Actuators</p>
<p>1) Solder with paying attention to the polarity. 2) Bond with paying attention to the base line of the bond.</p>	<p>1) Be careful to damage the Camera and Sub PCB-FPCB</p>
<p>3</p>  <p>1) Open the Actuator on the Sub PCB. 2) Insert S-FPCB to the Actuator and Close the Actuator.</p>	<p>4</p>  <p>1) Attach the Insulating tape on the Actuator.</p>
<p>1) Be careful to damage the S-FPCB</p>	<p>1) Pay attention to the base line.</p>

5

Keep in order the wire

1) After place the LCD on the window, place the Camera on the Upper.
2) After insert the Speaker wiresto the wire gap, place the Speaker on the Upper.

1) Be careful to damage the Speaker wires.

6

1)

1) Attach the fixing tape on the bottom of the LCD.
2) Place the Sub PCB on the Upper orderly.

1) Be careful to damage the Sub PCB by the hooks.

7

1) Put in the Lower Orderly.

1) Assemble anti-clockwise.

8

1) Tighten 4 screws on the Lower orderly.
2) Attach 2 screw caps on the top of the Lower.

1) Don't scratch the surface of the handset. Please pay attention.

9

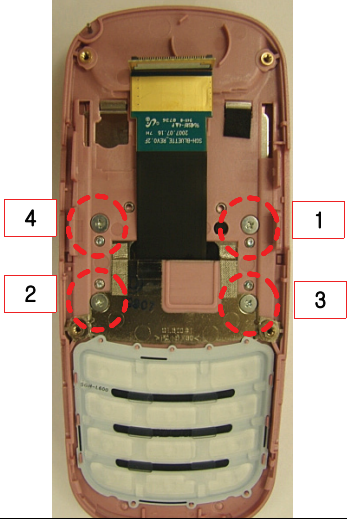

1) After Place the Front on the Lower , Tighten 4 screws.
2) Place the Key-PAD on the Front.

1) Don't scratch the surface of the handset. Please pay attention.

10

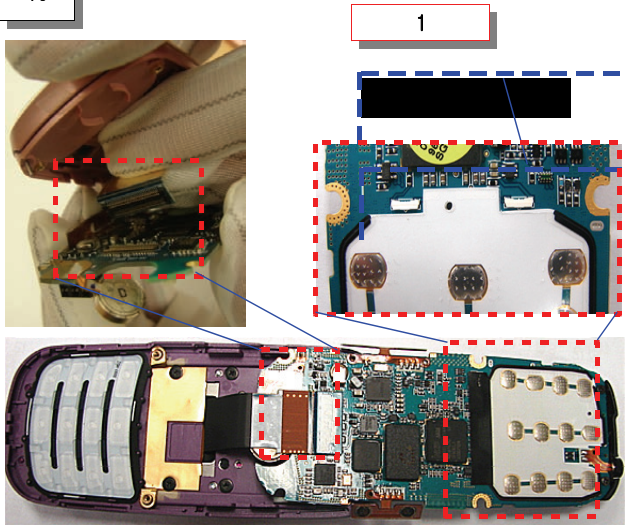

1) Attache the shading tape on the Main PBA base line
1) Insert S-FPCB on the Main PBA Connector.

1) Be careful to damage the S-FPCB.

11

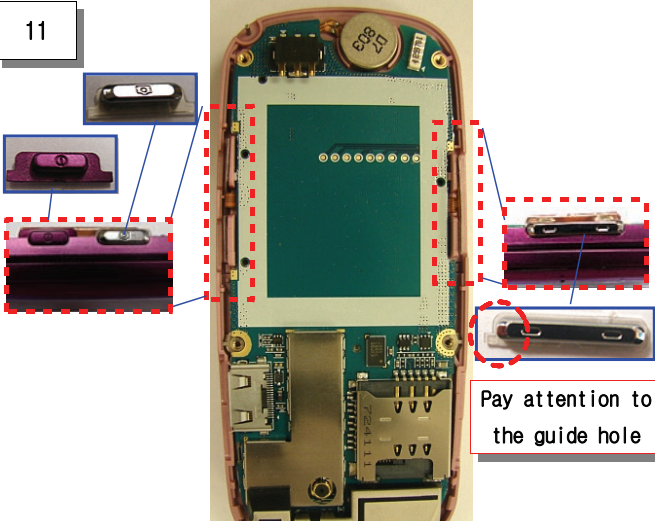

1) Attach the Volume and Camera key FPCB on the Ribs.
2) Insert the Volume, Camera and power key to guide holes.

1) Pay attention to the direction.

12

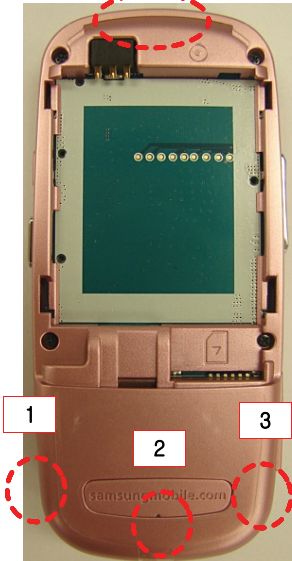

1) Put in the Lower on the Fornt from Top to bottom clockwise.

1) Pay attention to gap.

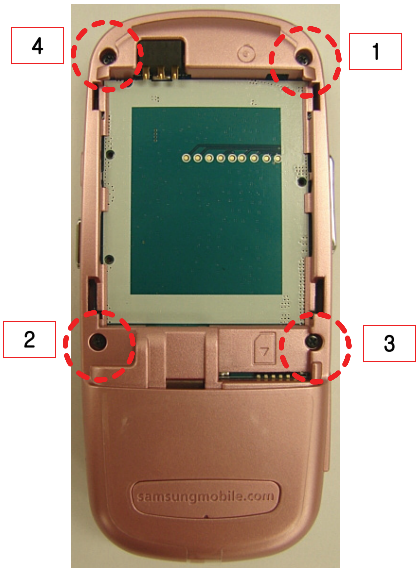
<p>13</p>  <p>1) Tighten 4 Screws of the Rear orderly.</p>	
<p>1) Don't scratch the surface of the handset. Please pay attention.</p>	

9. Flow Chart of Troubleshooting

9-1. Power On

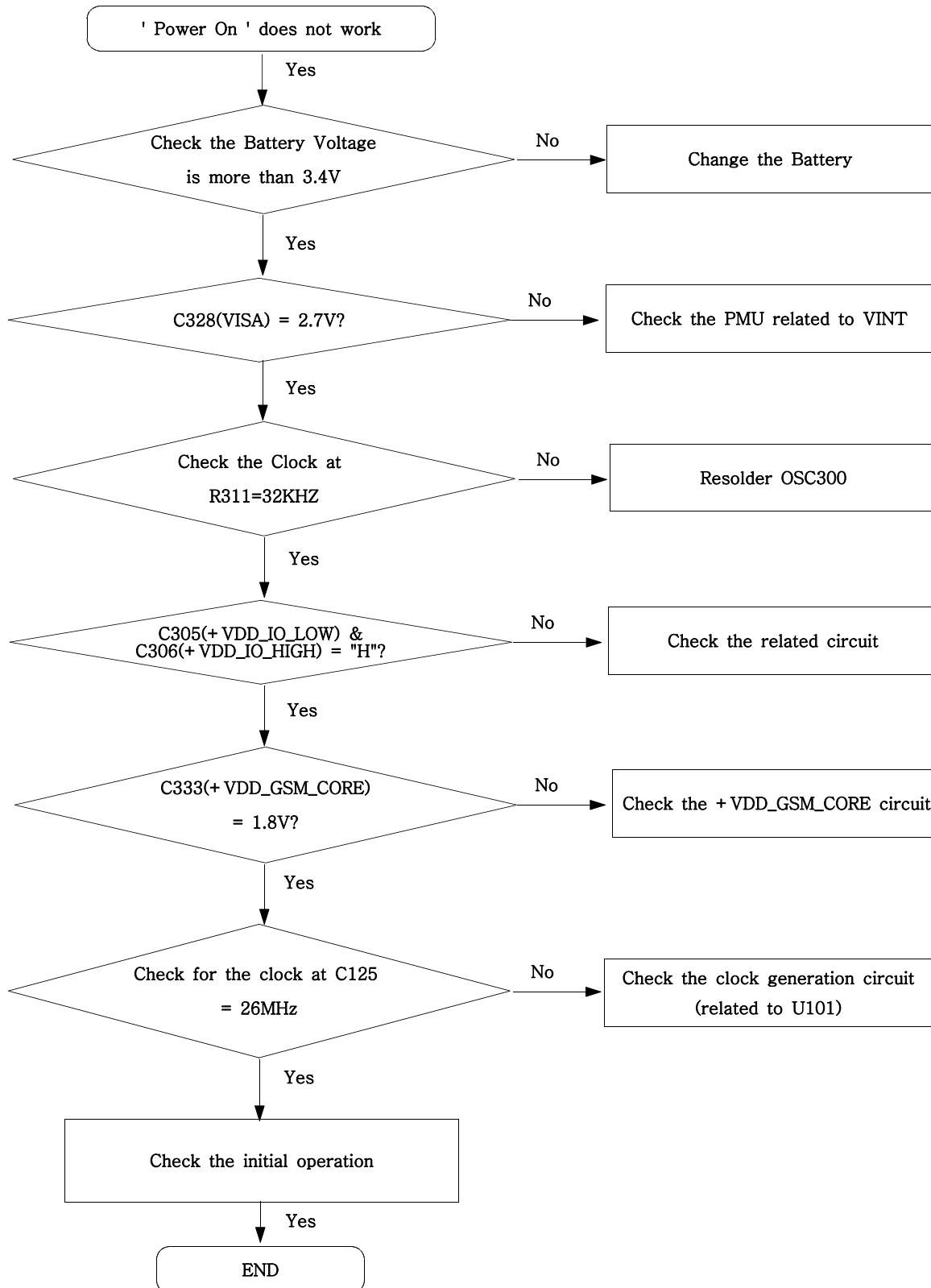

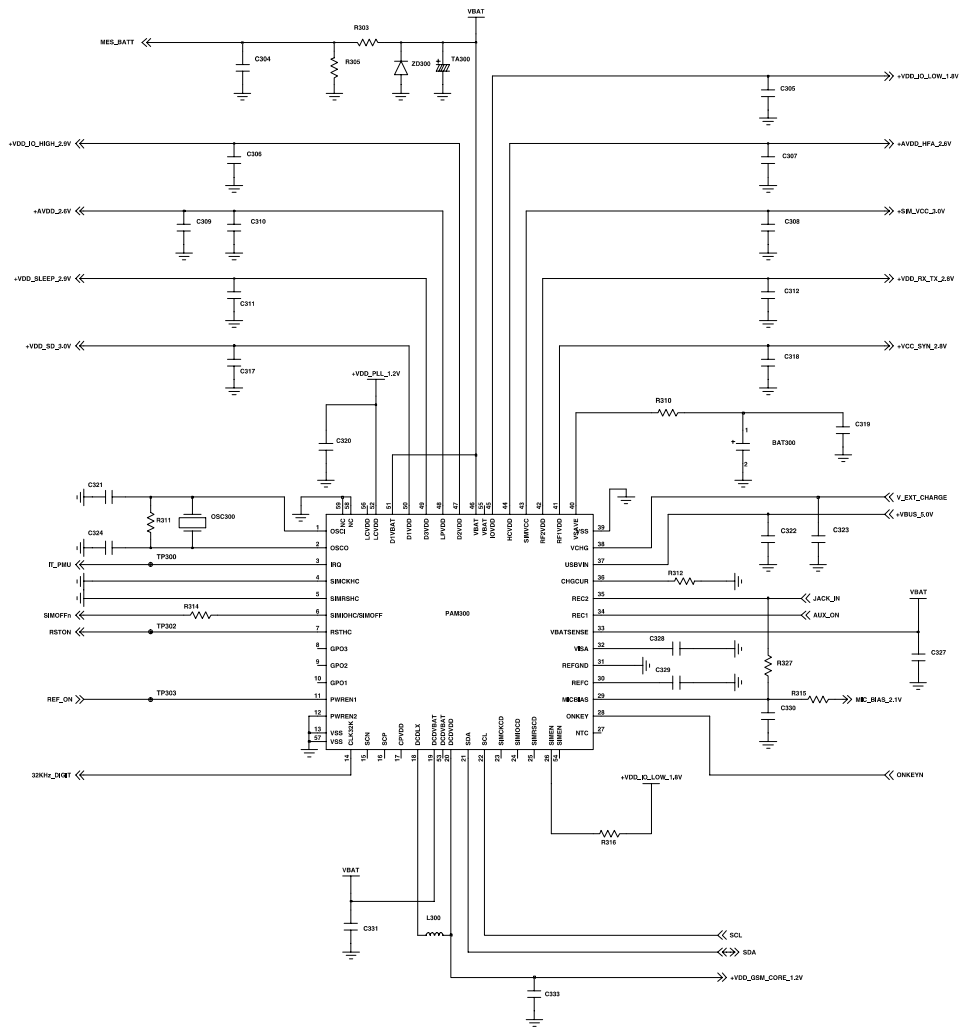

PMU - PCF50611 (PMU + DCDC + CHARGER)

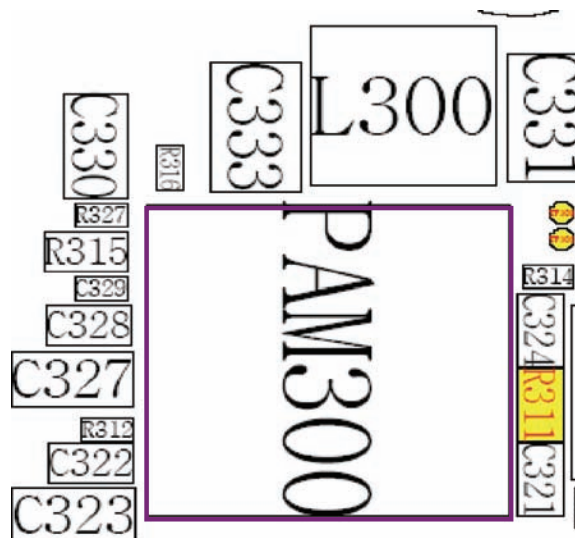

9-2. Initial

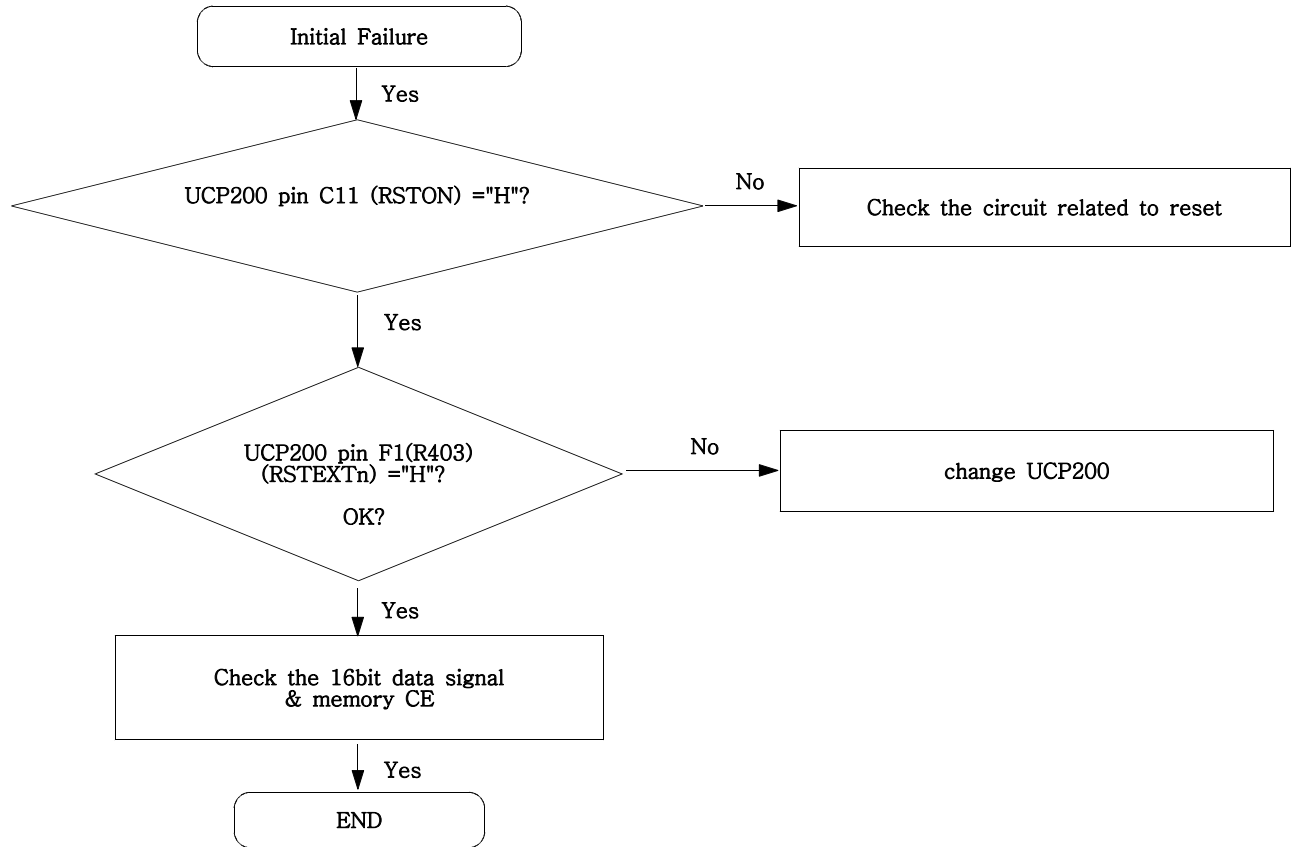

Flow Chart of Troubleshooting

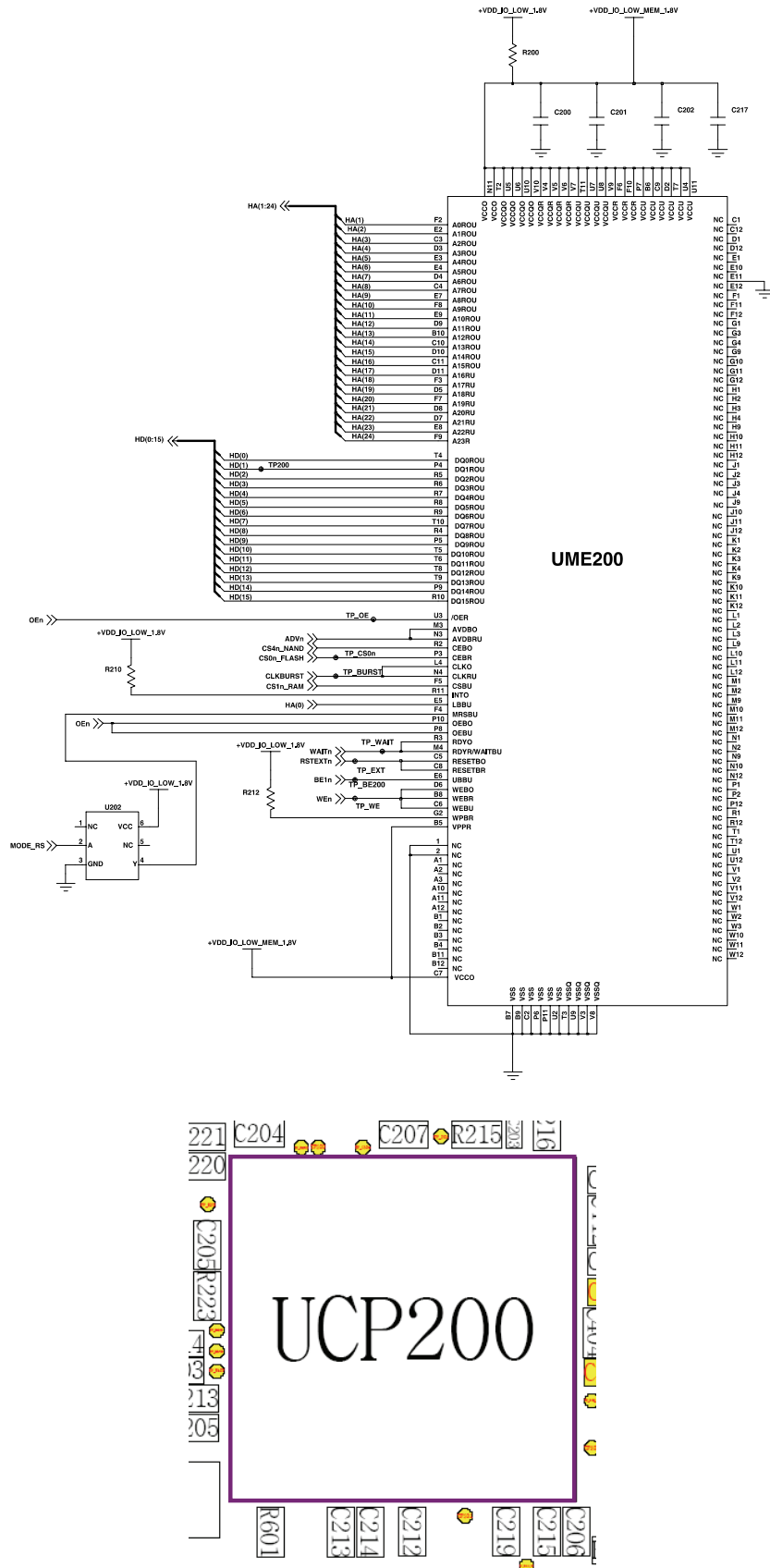

9-3. Charging Part

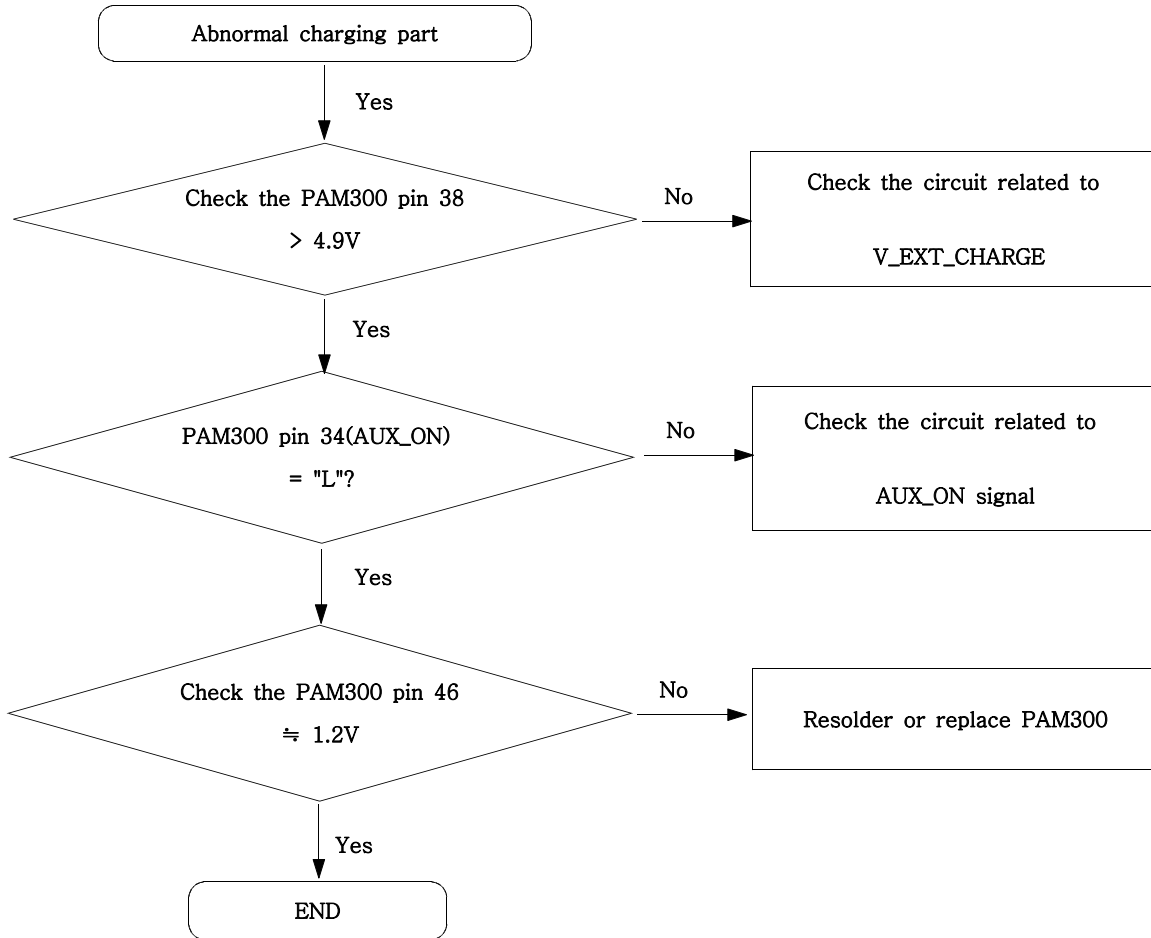

9-4. Sim Part

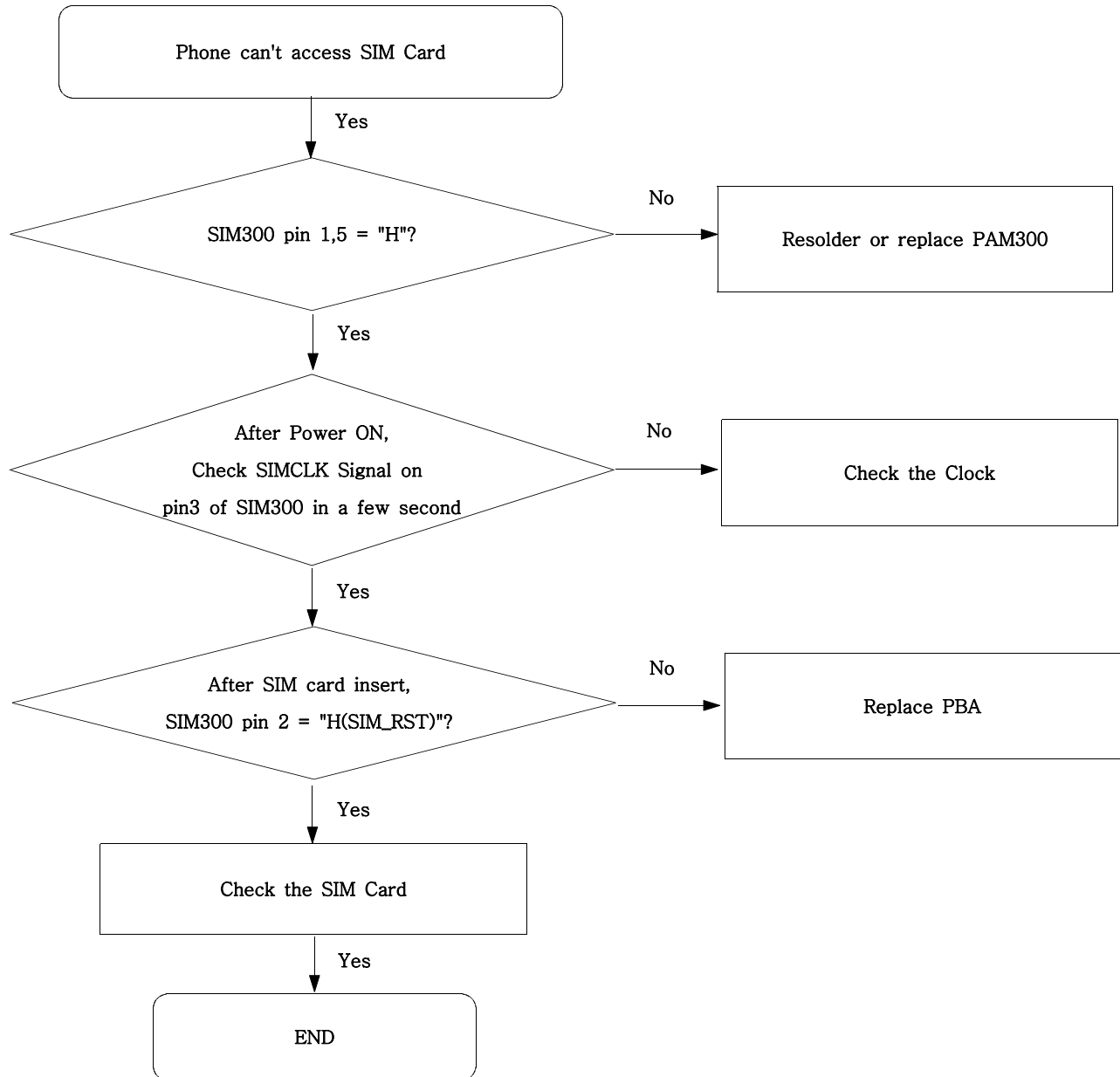

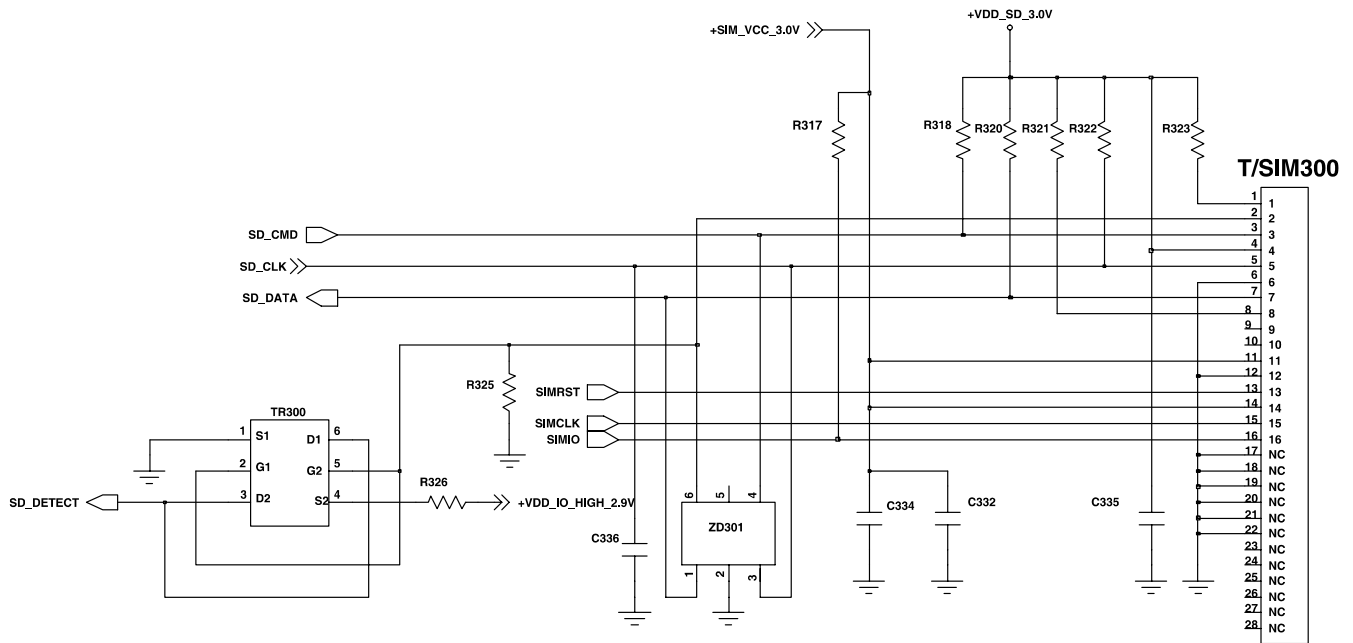

T-flash / USIM Socket

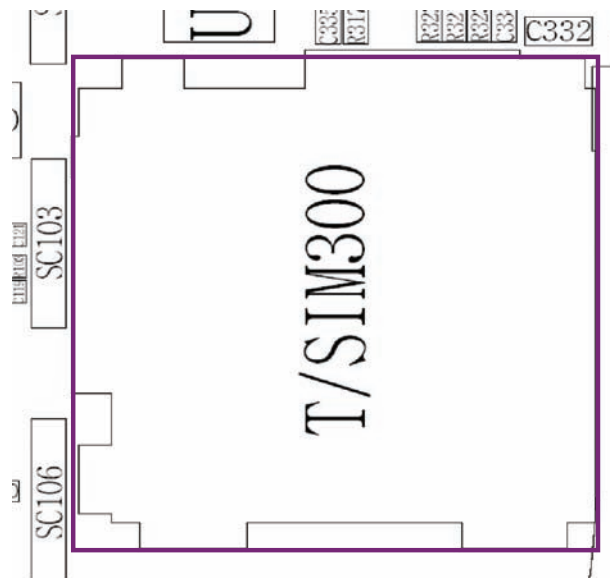

9-5. Microphone Part

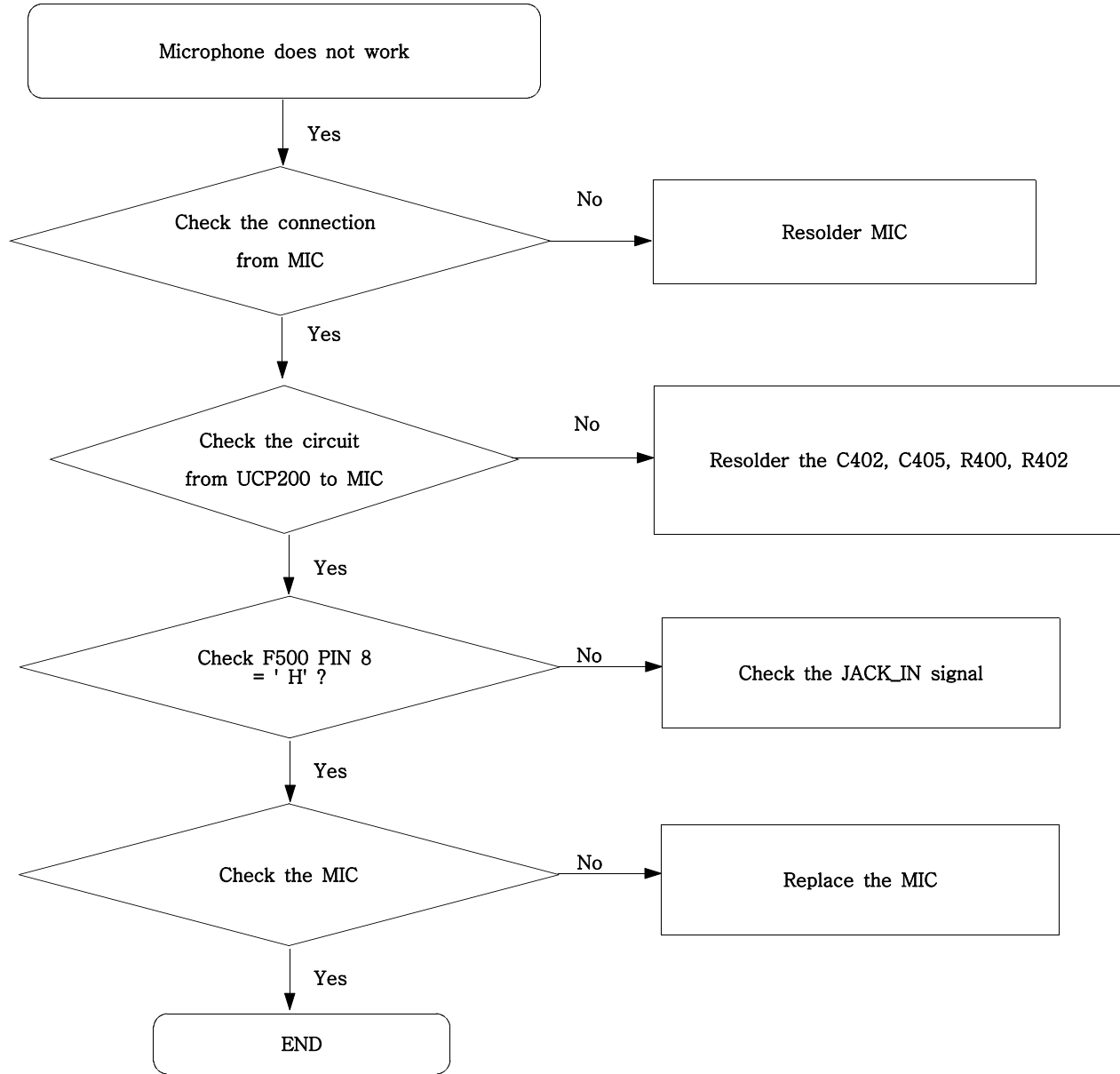

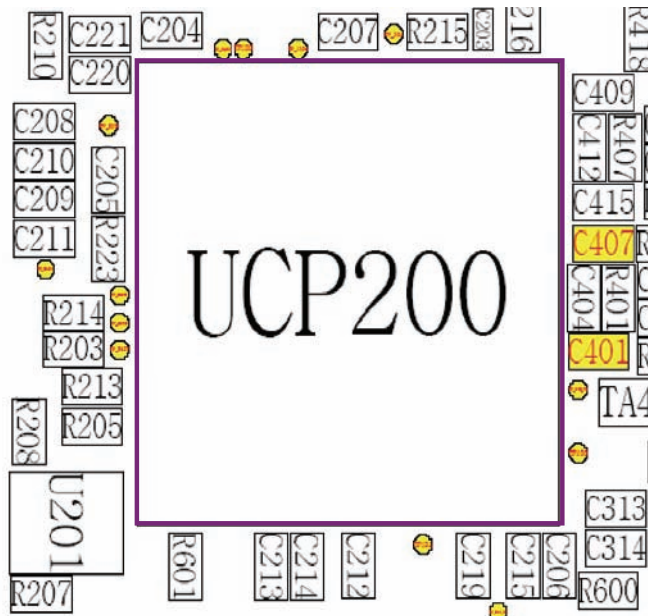
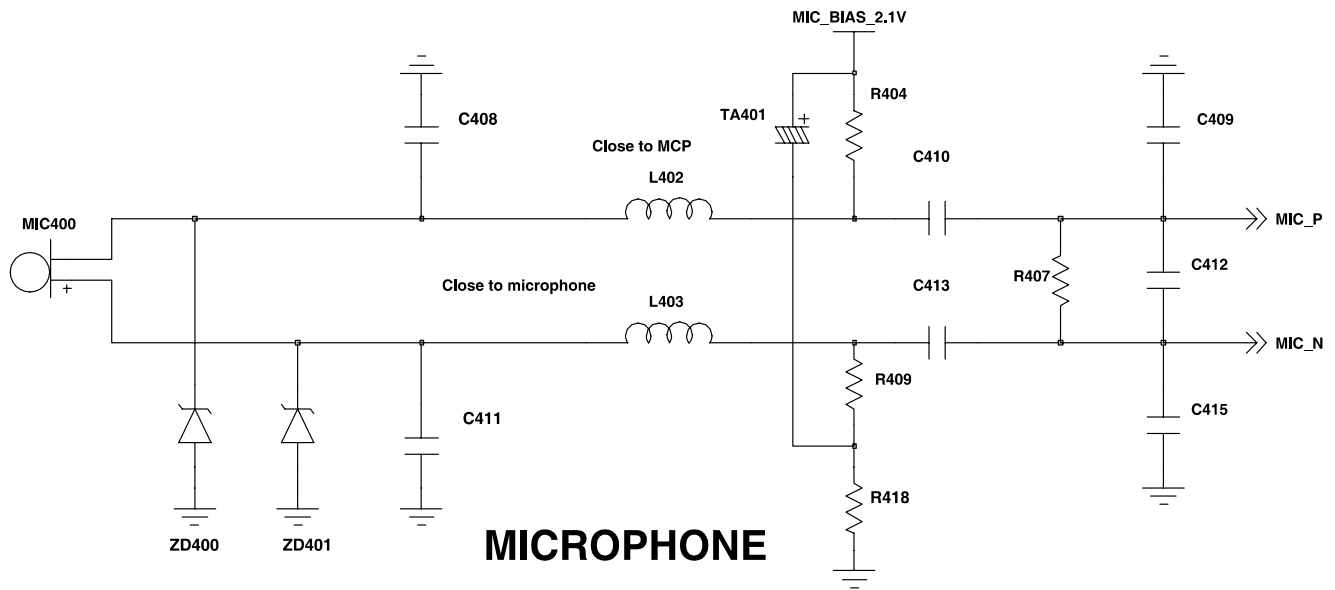

9-6. Speaker Part(Melody)

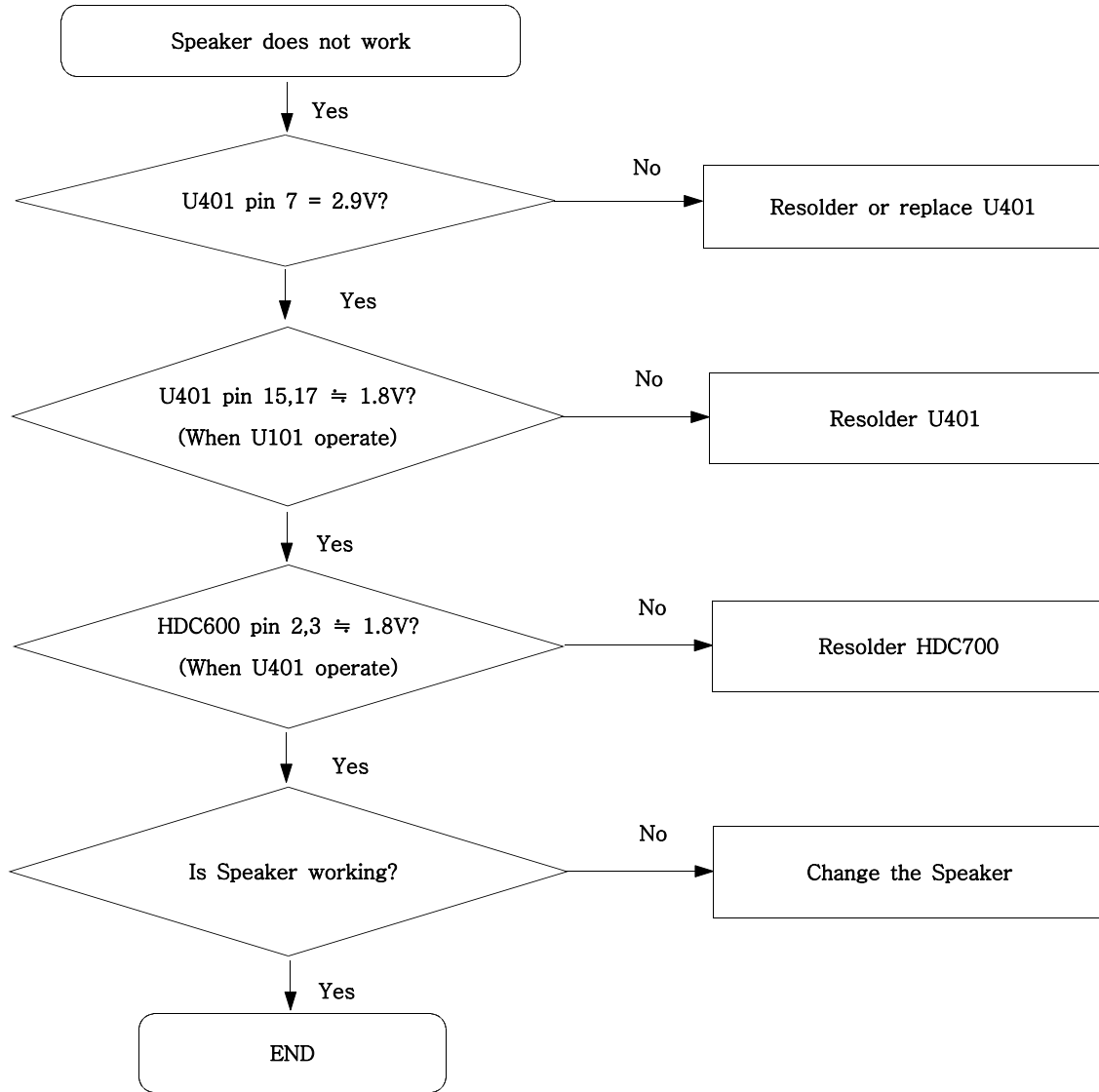

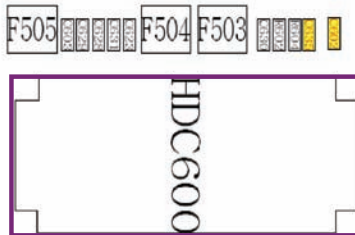
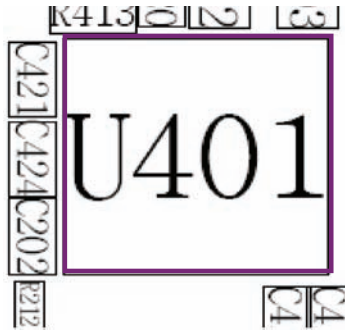
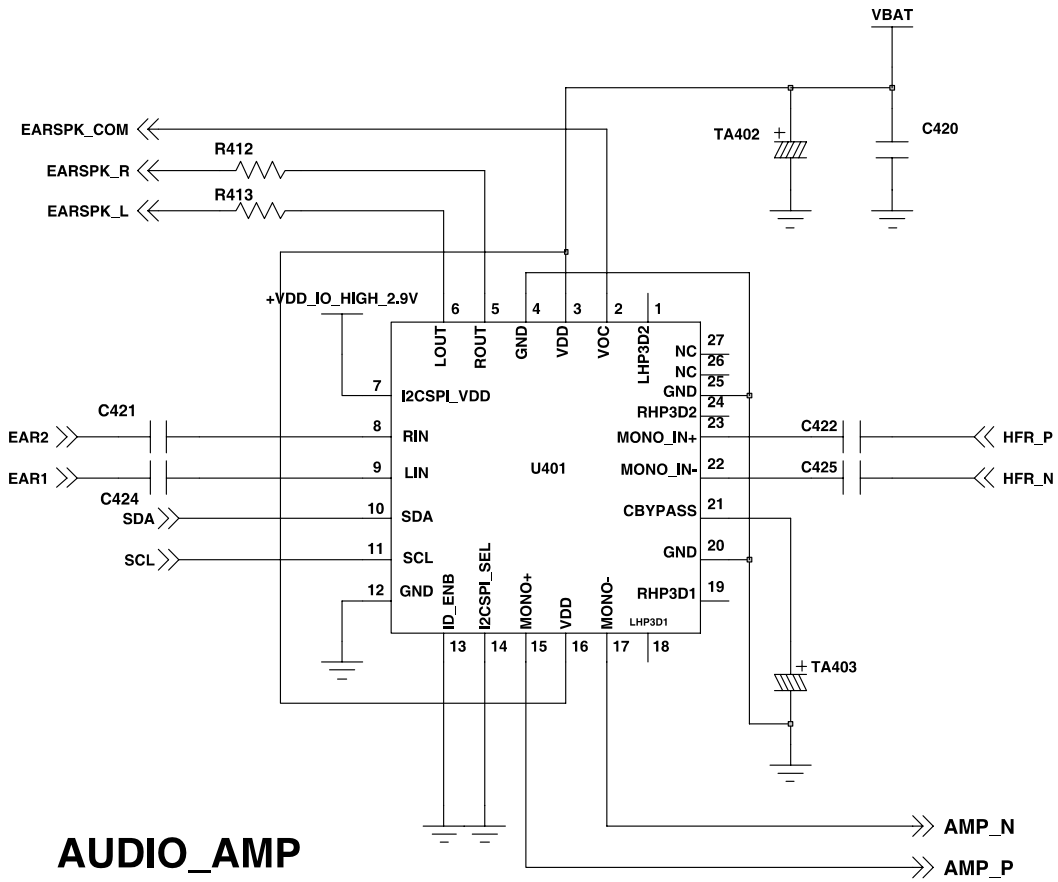

9-7. Key Data Input

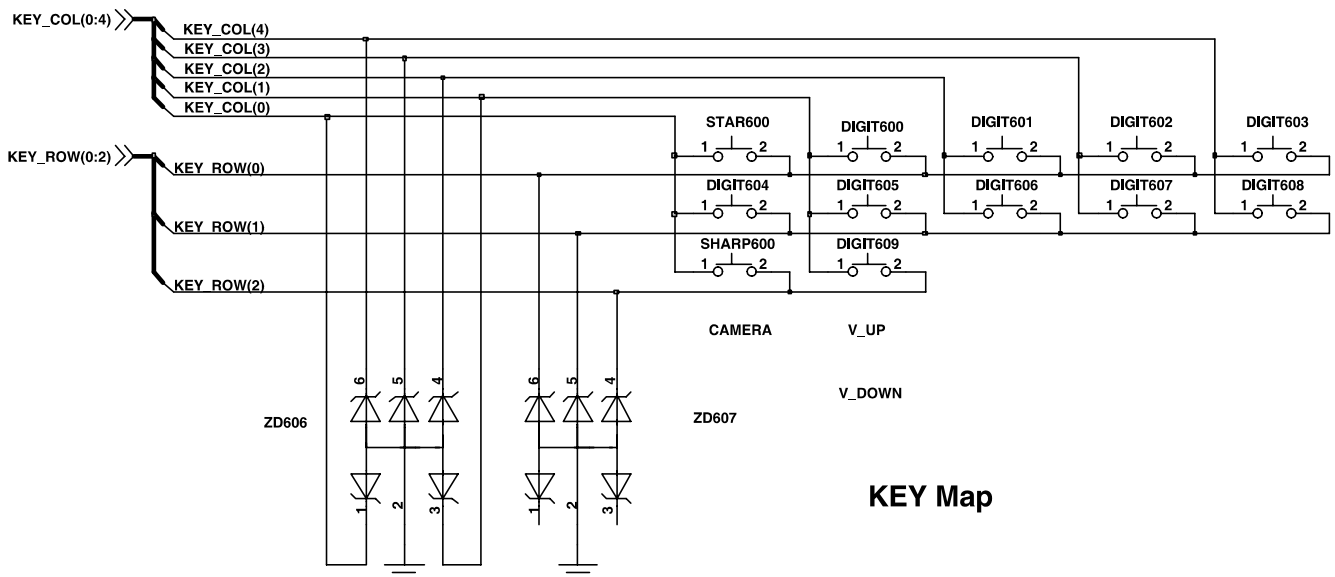
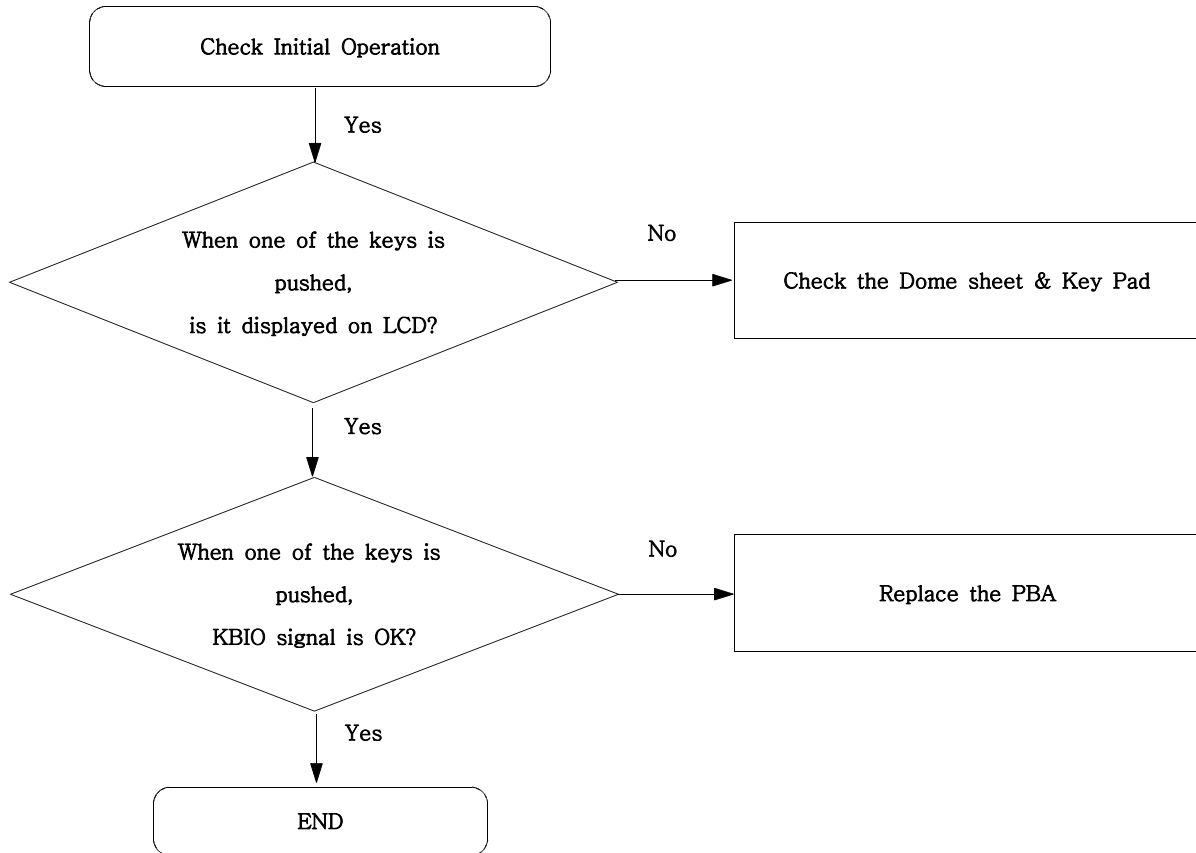

9-8. Receiver Part

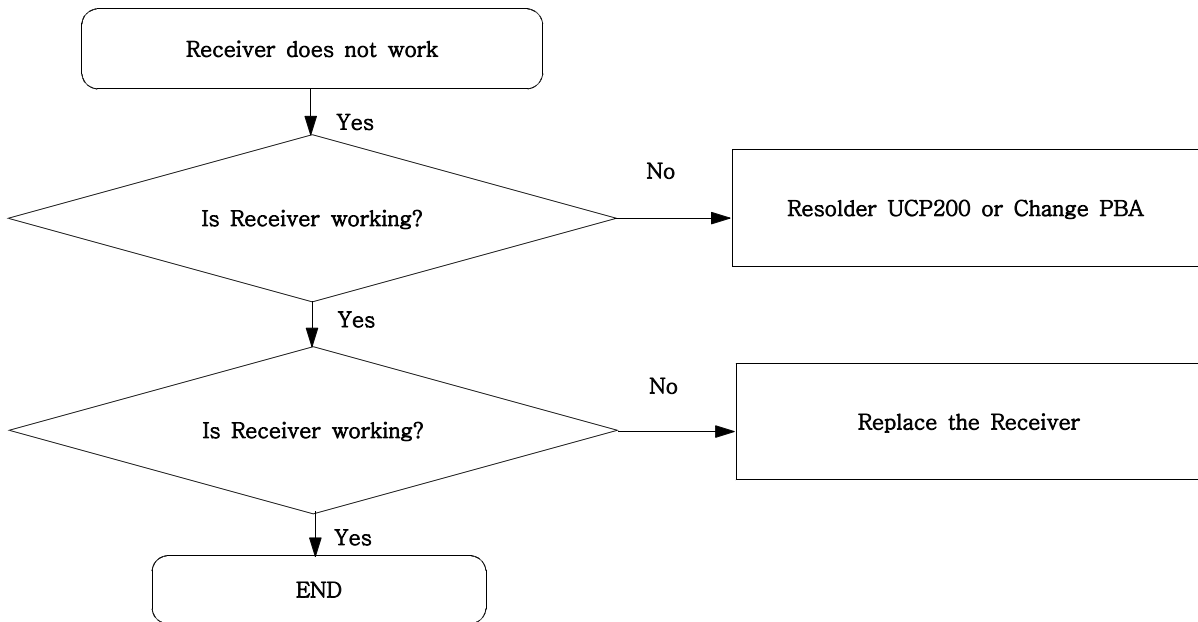

9-9. Back Light (for Color Main LCD)

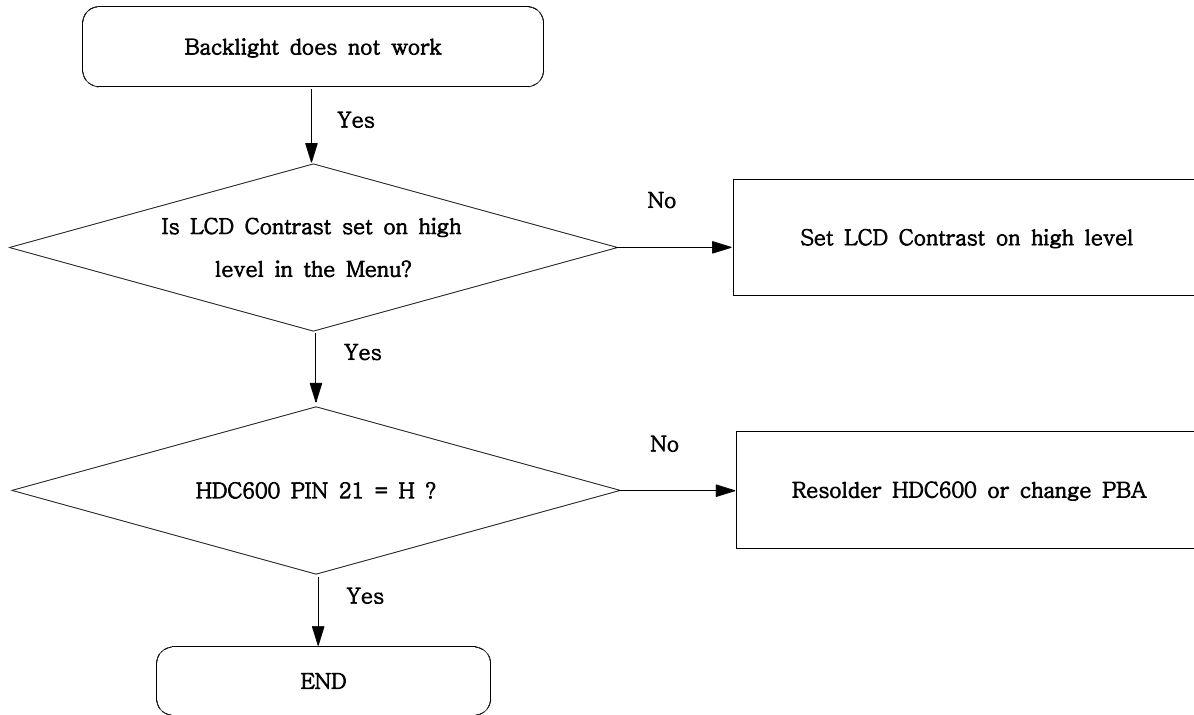

Flow Chart of Troubleshooting

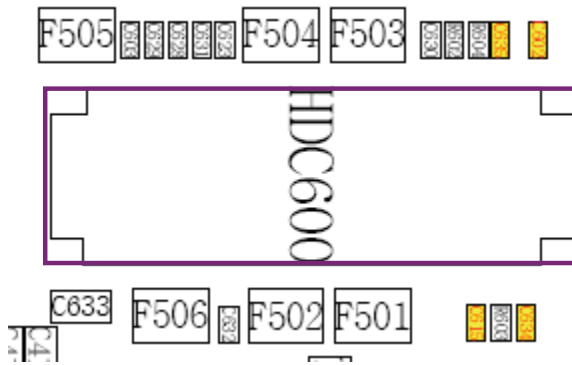
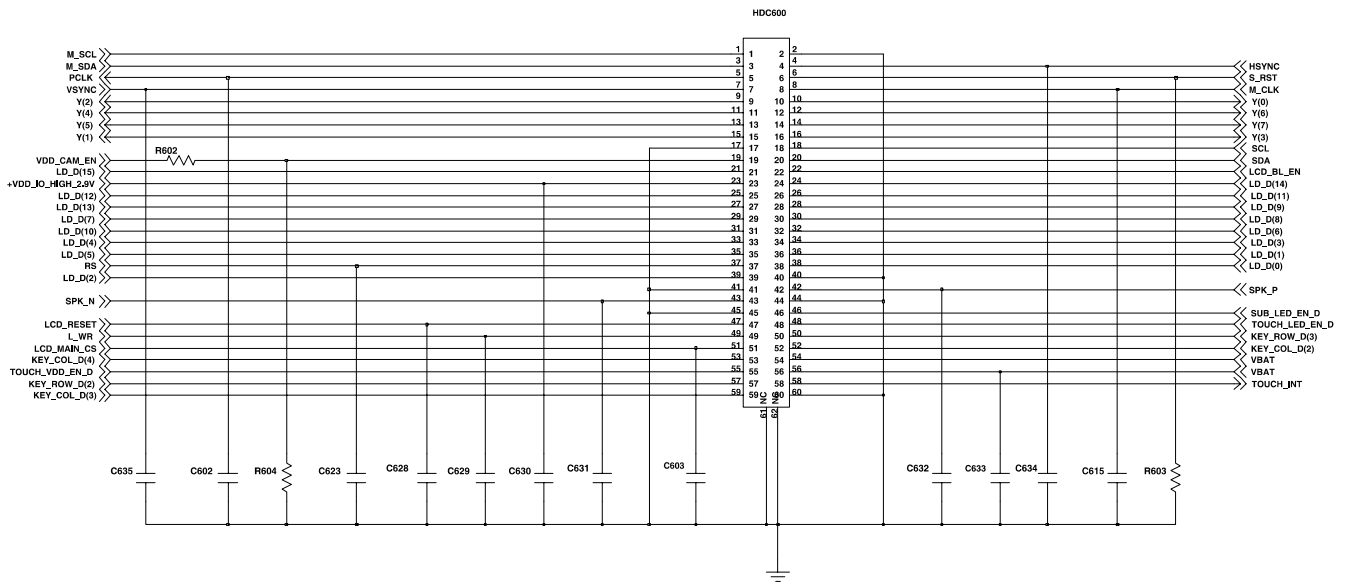

9-10. Key Back Light

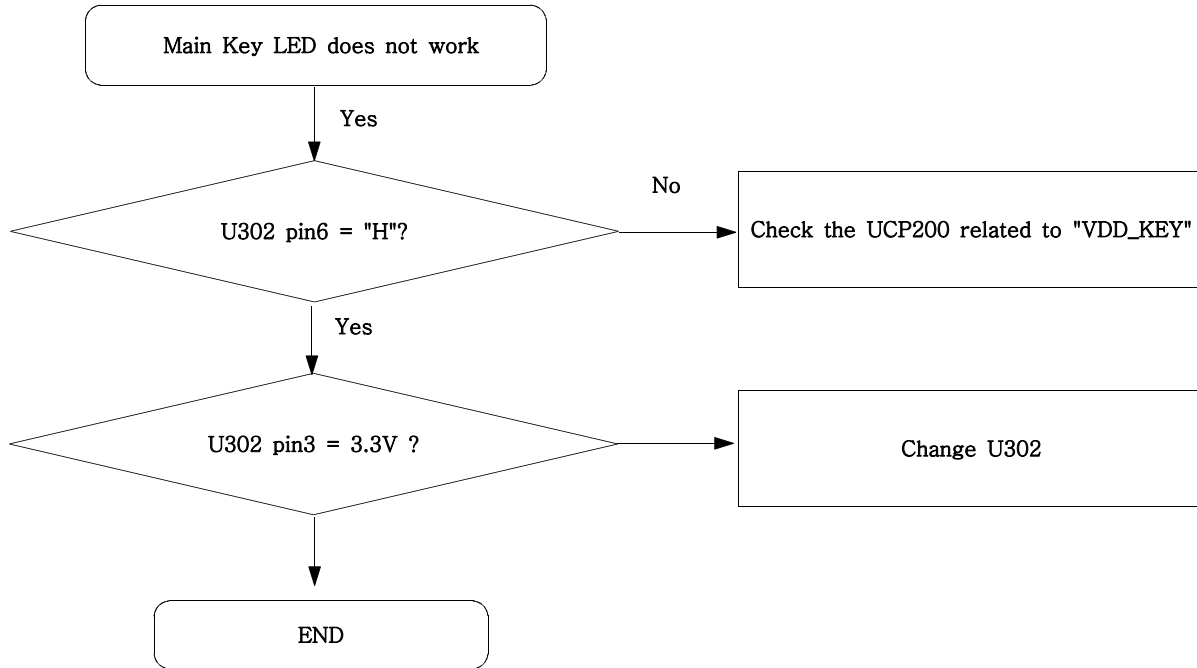

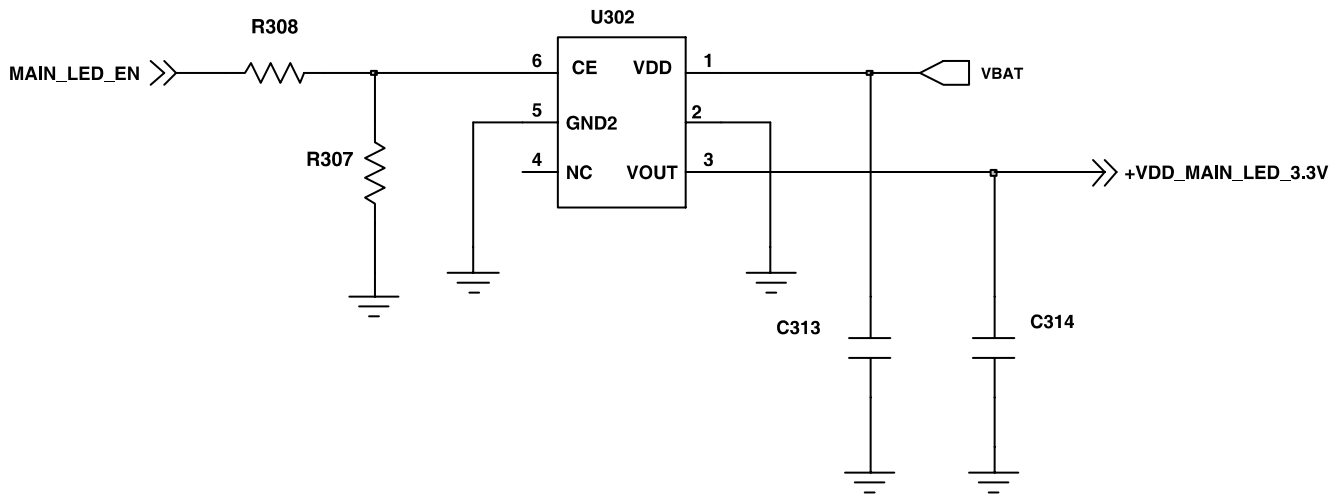

MAIN_LED_POWER_3.3V

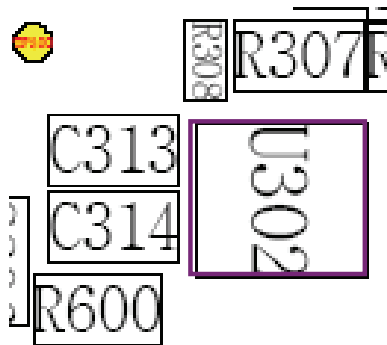

9-11. Camera part

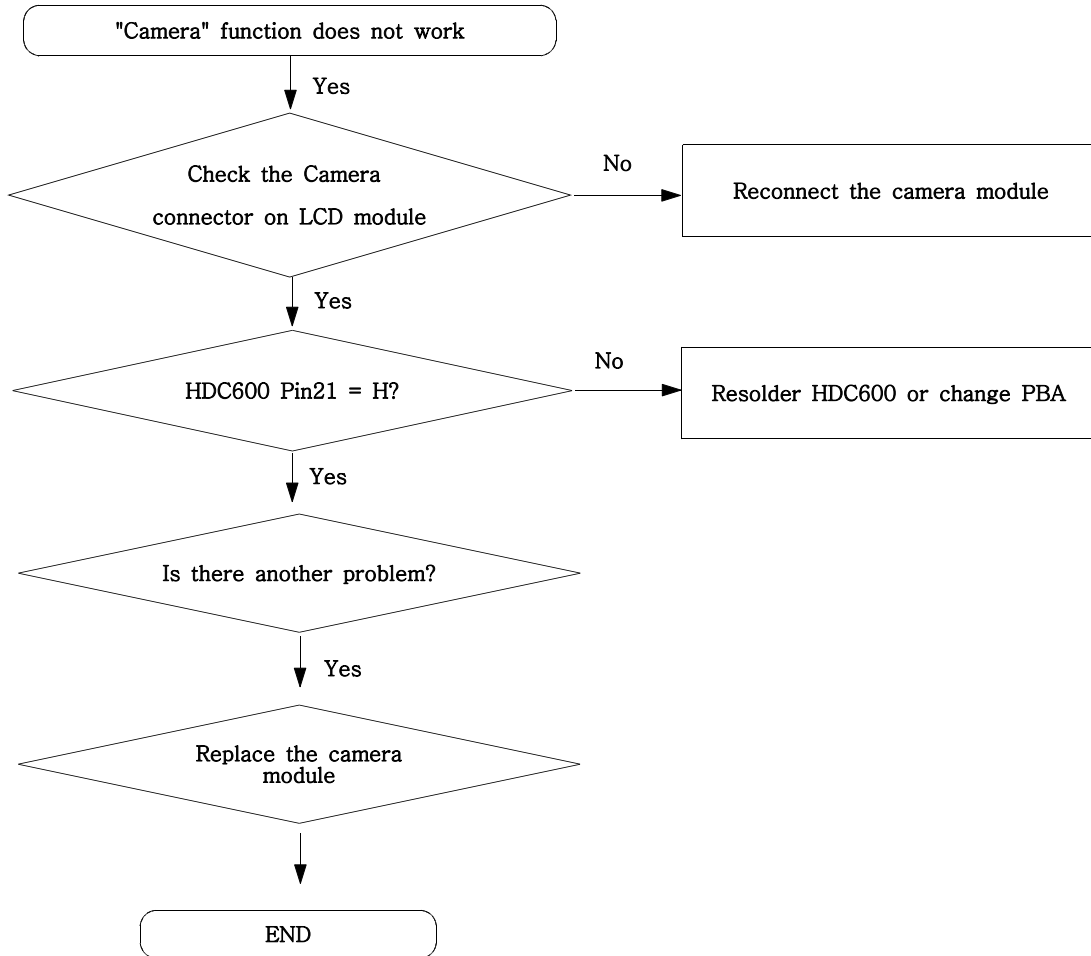

Flow Chart of Troubleshooting

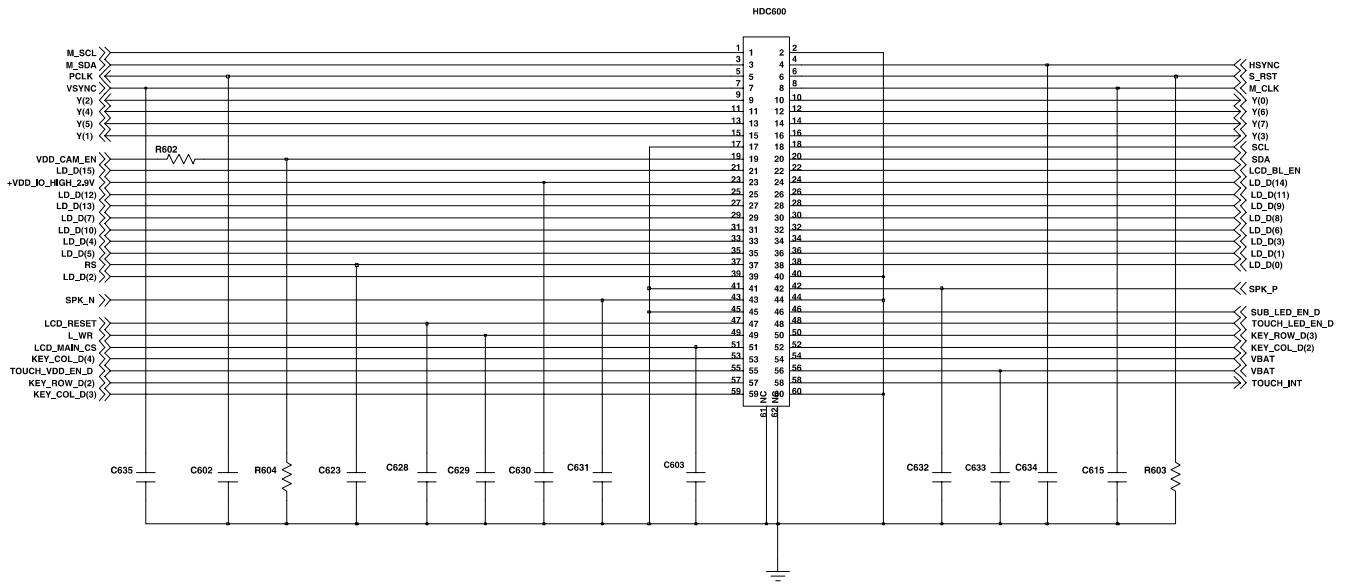

9-12. GSM Receiver

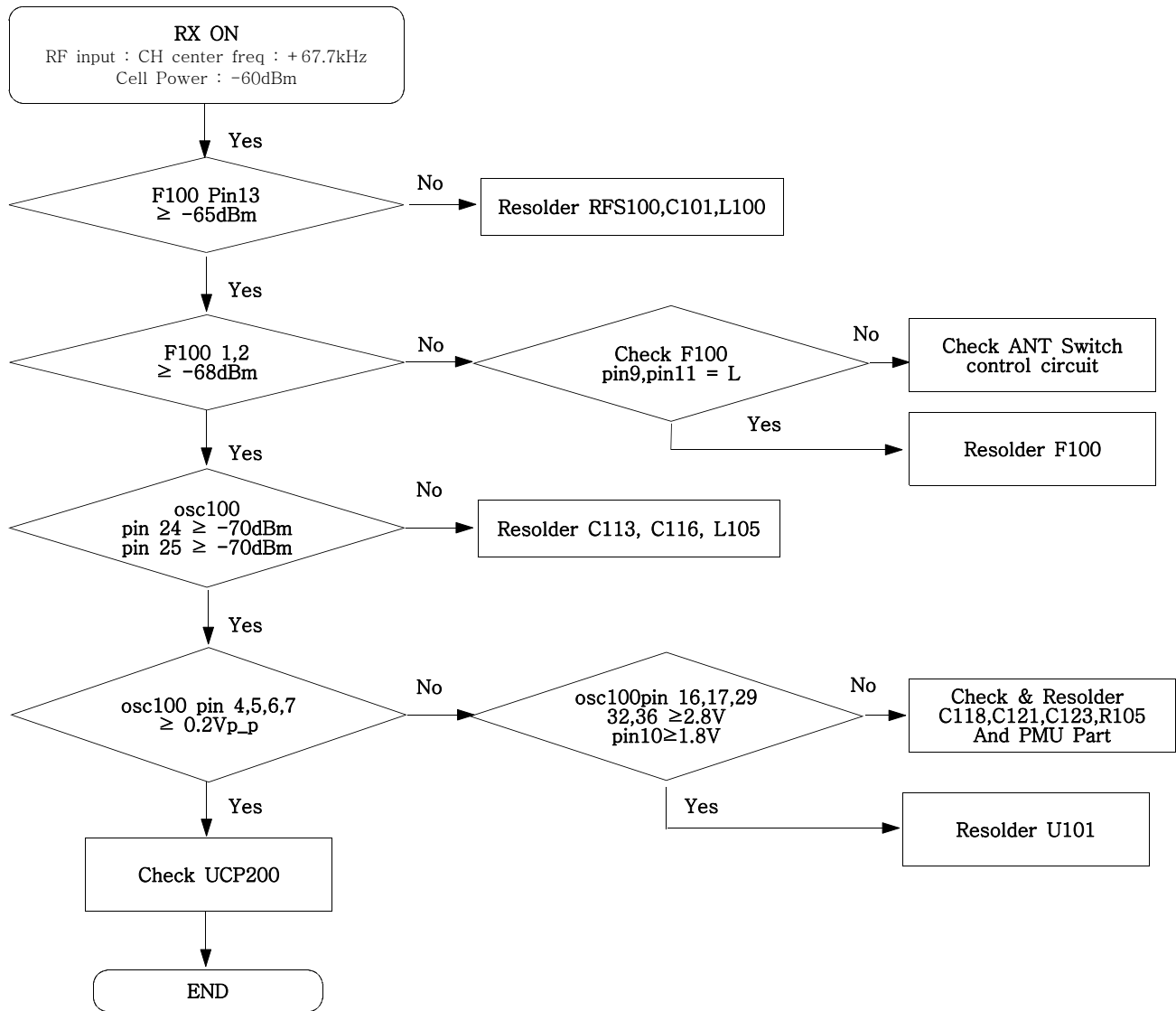

9-13. GSM Transmitter

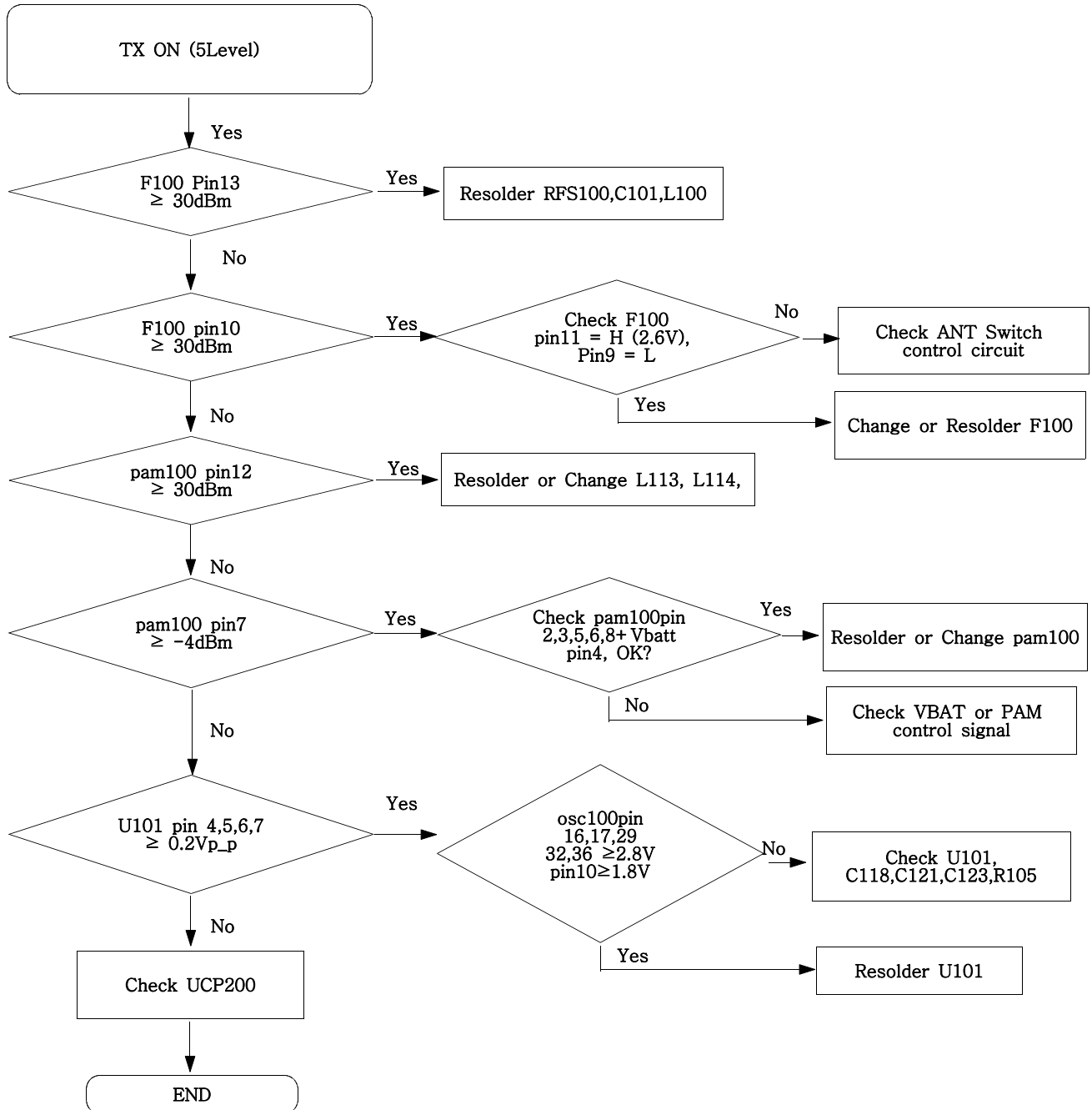

9-14. DCS Receiver

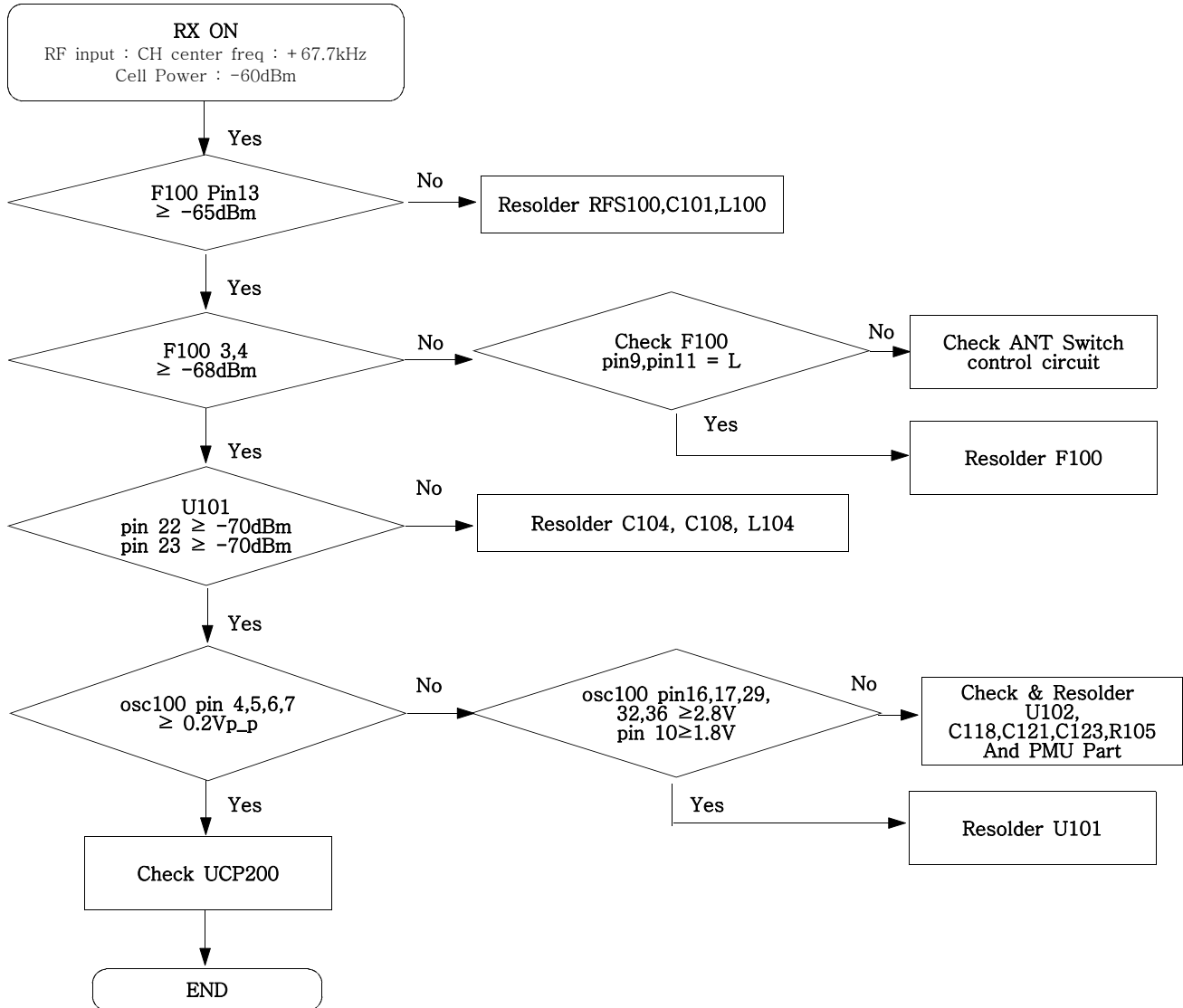

9-15. DCS Transmitter

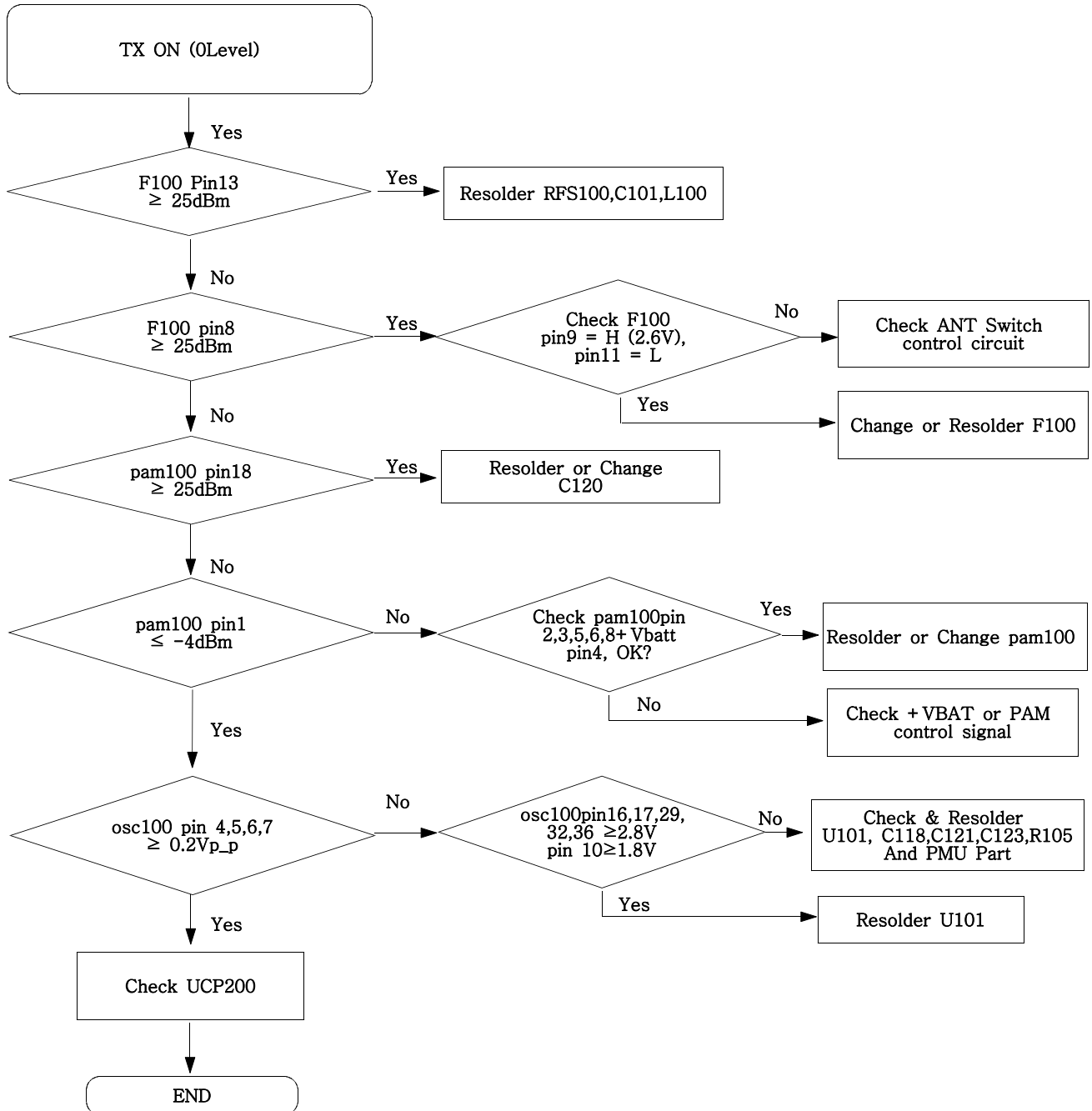

9-16. PCS Receiver

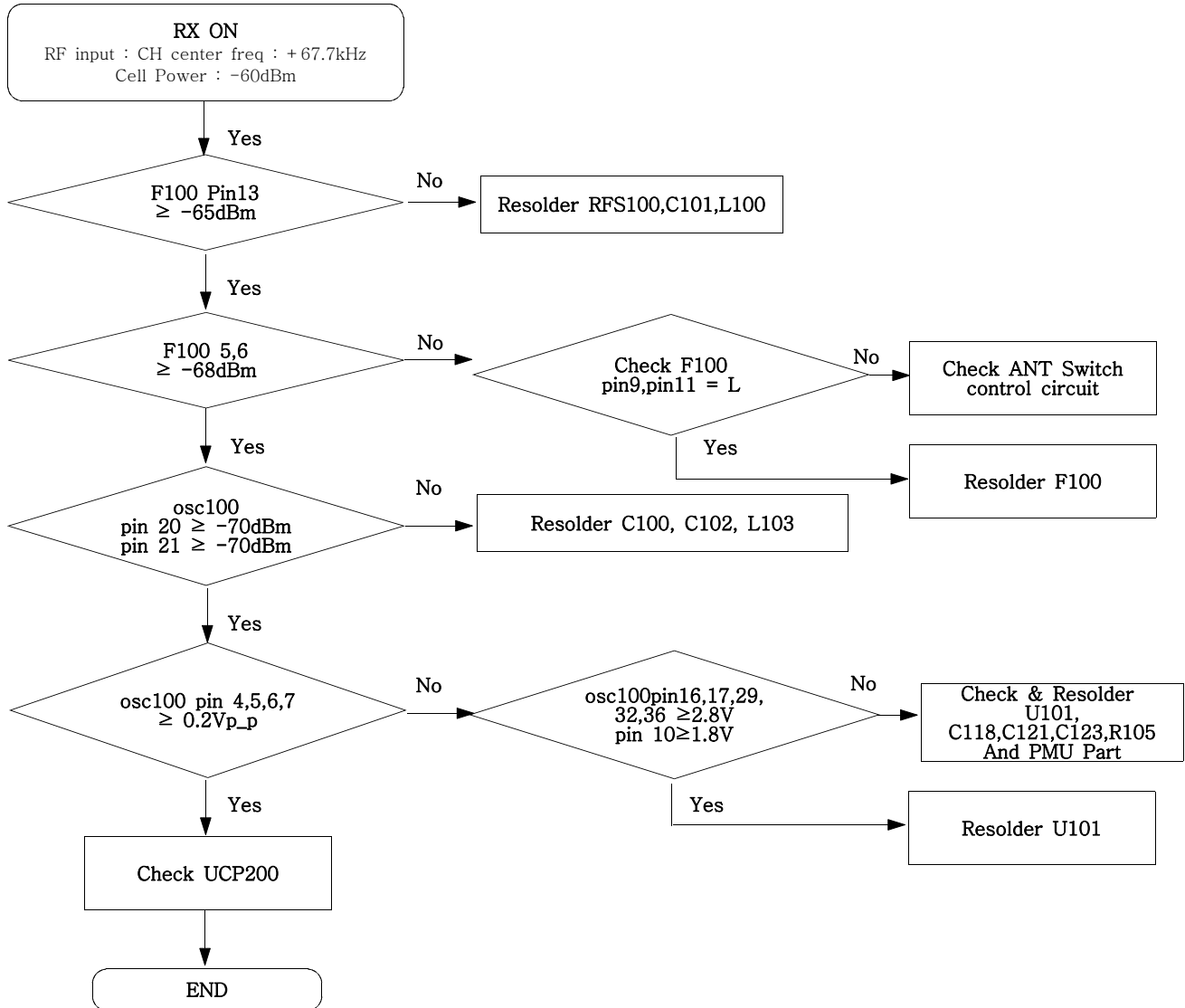

9-17. PCS Transmitter

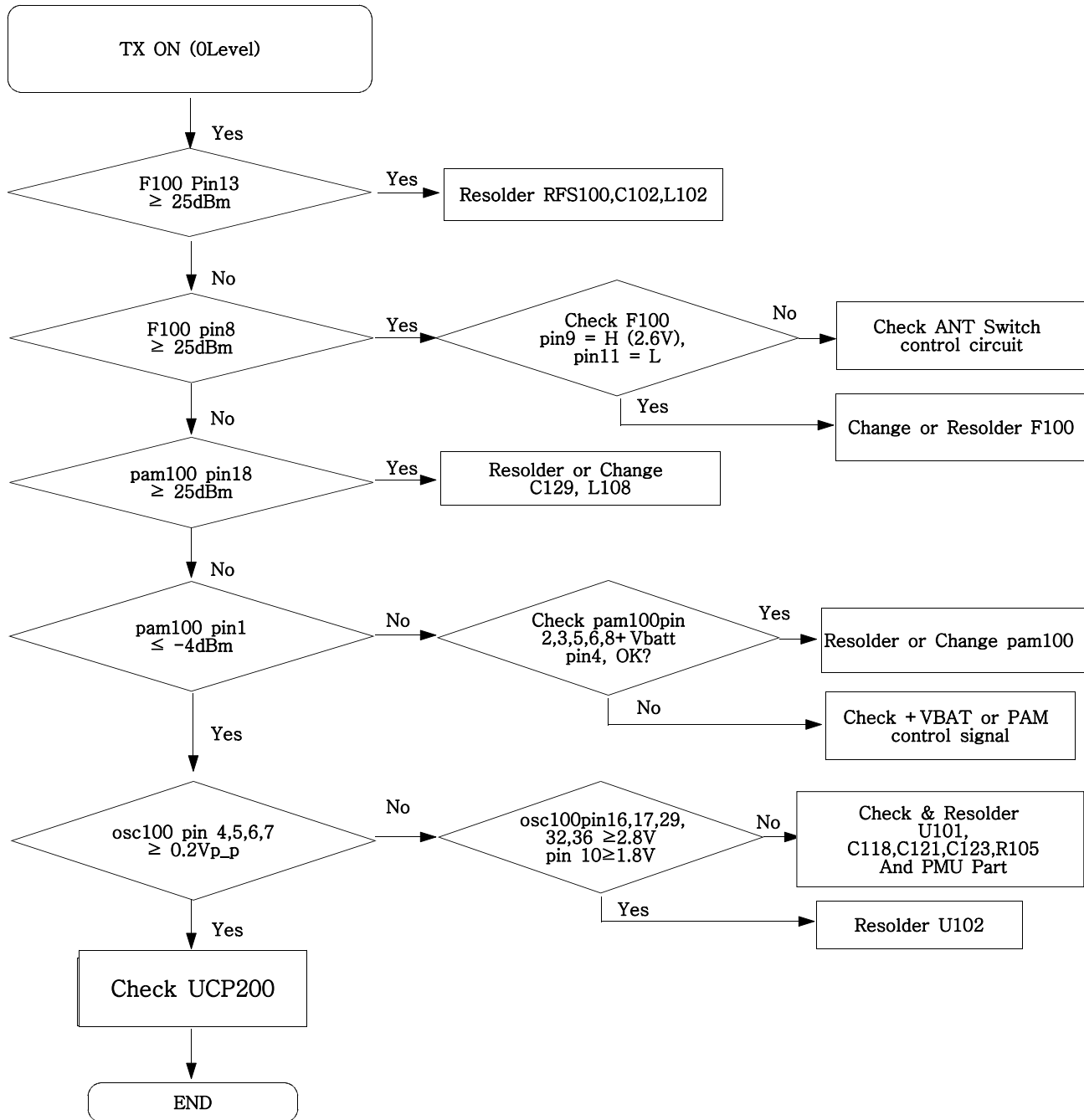

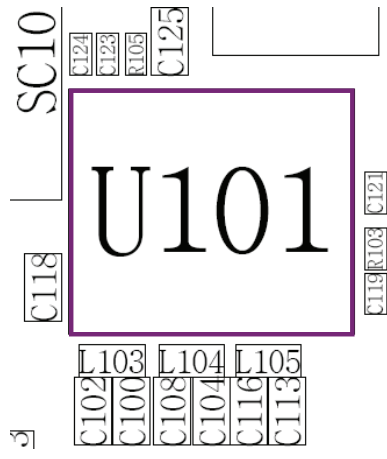
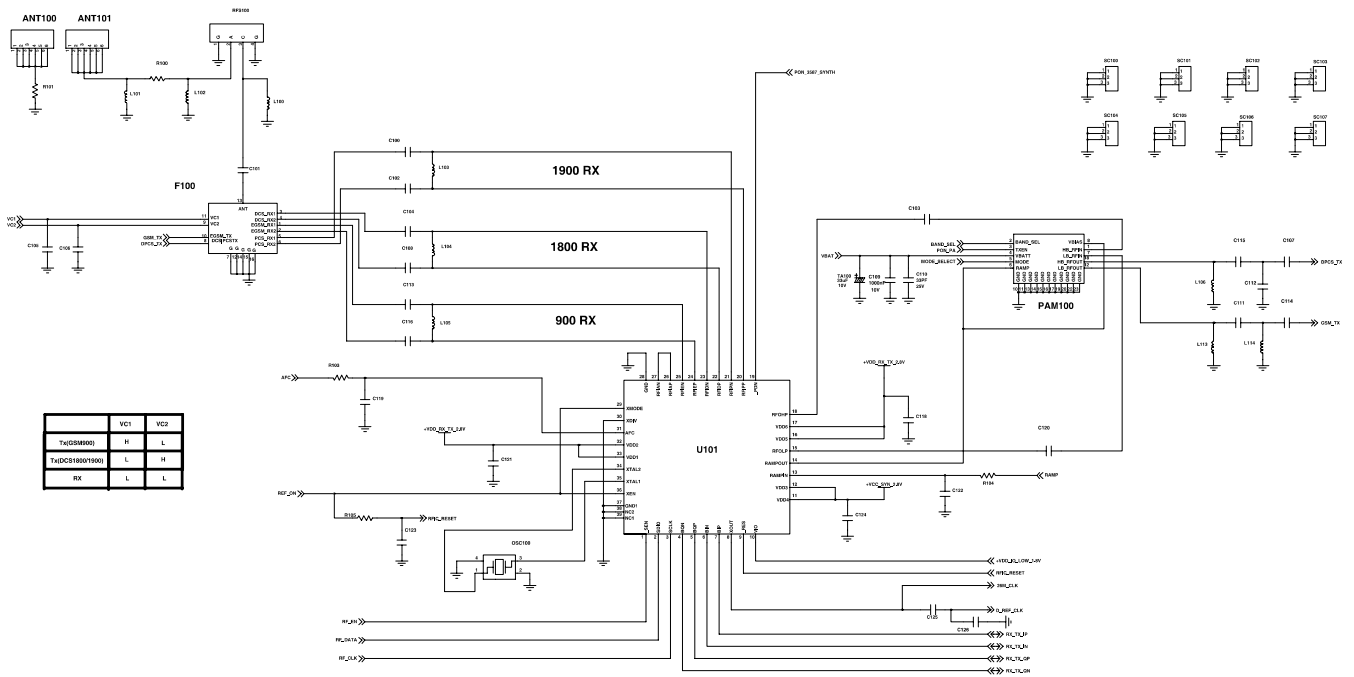

9-18. Bluetooth part

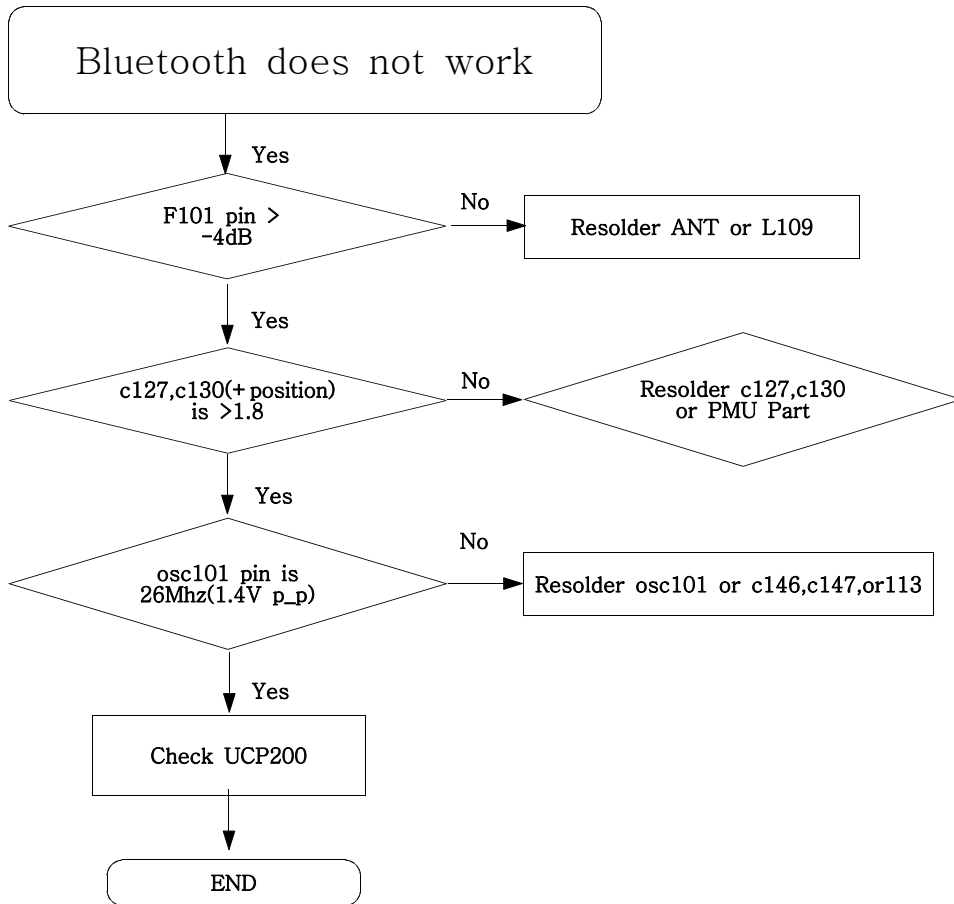

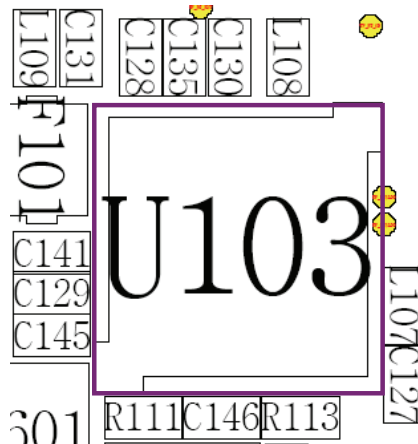
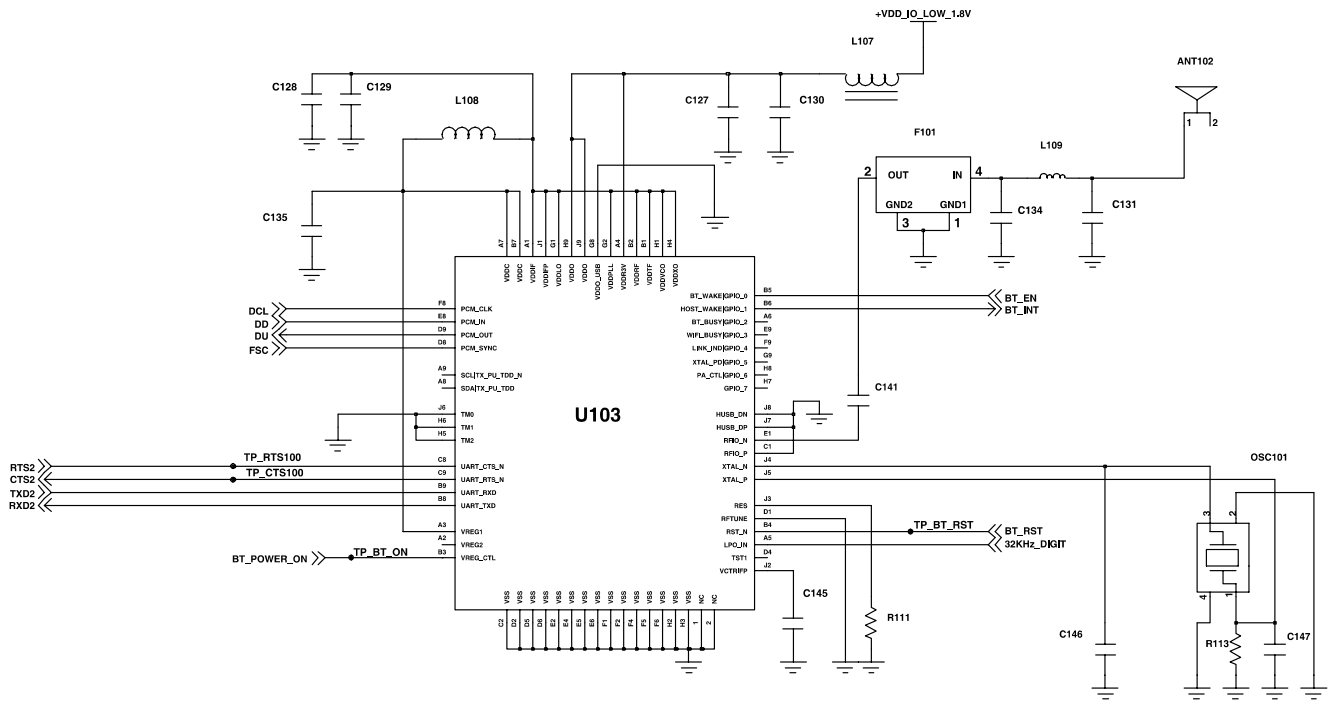

9-19. Radio part

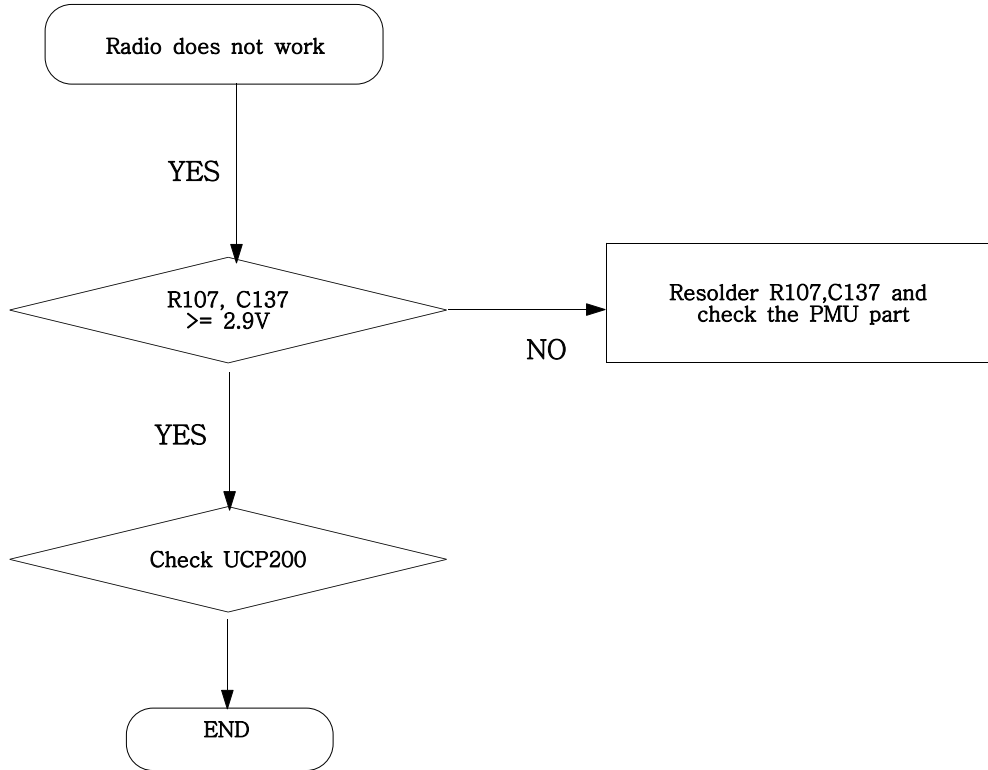

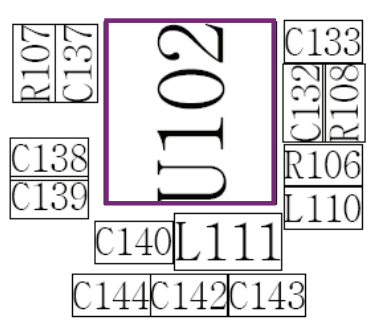
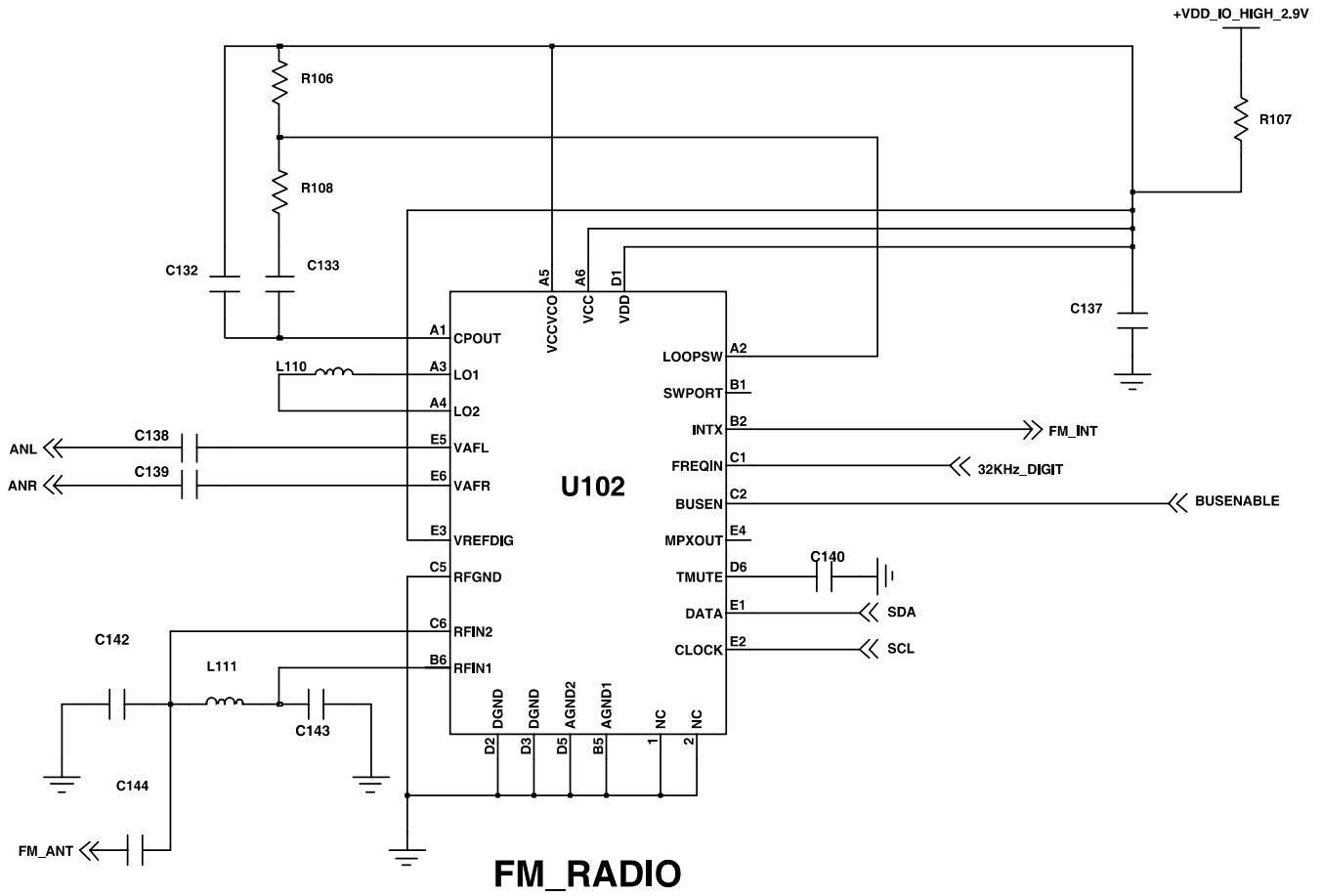

4. Array course control

4-1. Software Adjustments

Test Jig (GH80-03306A)

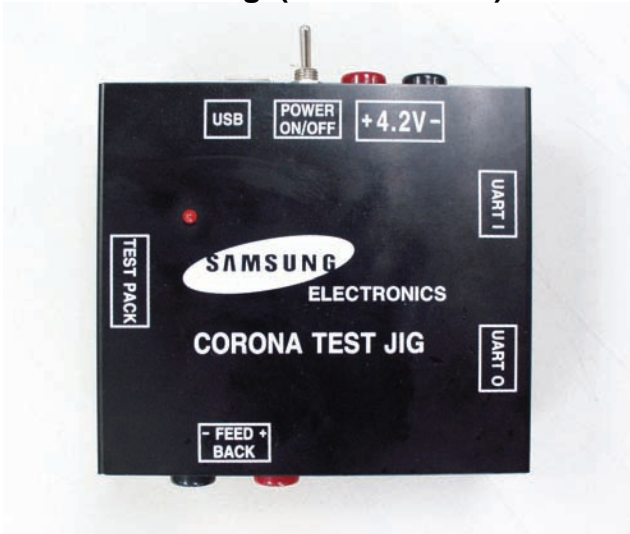

Test Cable (GH39-00499A)



Serial Cable(CSA LL64151-A)

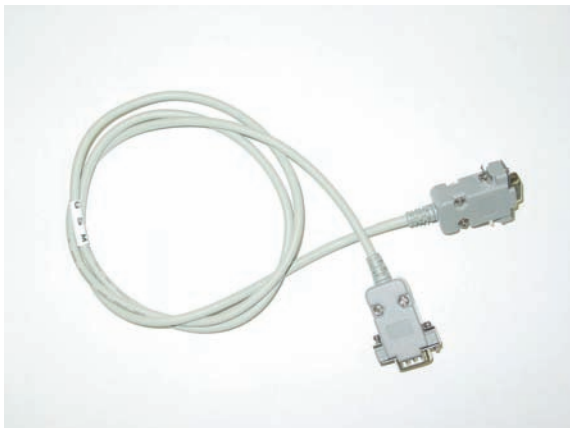

Power Supply Cable



4-2. Software Downloading

4-2-1. Pre-requisite for Downloading

- Downloader Program(OneNAND Downloader v1.5 Lite For PNx5230(tfs4 v1.6).exe)
- L600 Mobile Phone
- Data Cable
- Binary file, TFS file

4-2-2. S/W Downloader Program

■ Load the binary download program by executing the “OneNAND Downloader v1.5 Lite For PNx5230”

1. Select the connected serial port and the rate of speed
2. Select the check box, the mode you want to download.
 - if the binary file wanted, check only 'BIN'
 - if the tfs file wanted, check only 'TFS'
 - if all the files wanted, check 'BIN+TFS'

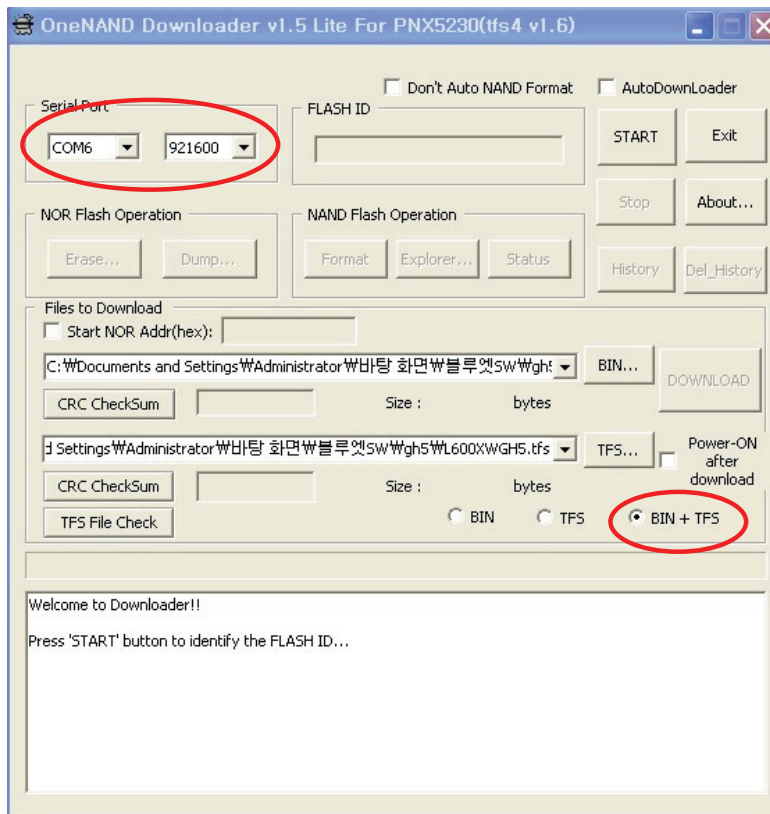

3. Select the file(s) what you want to download

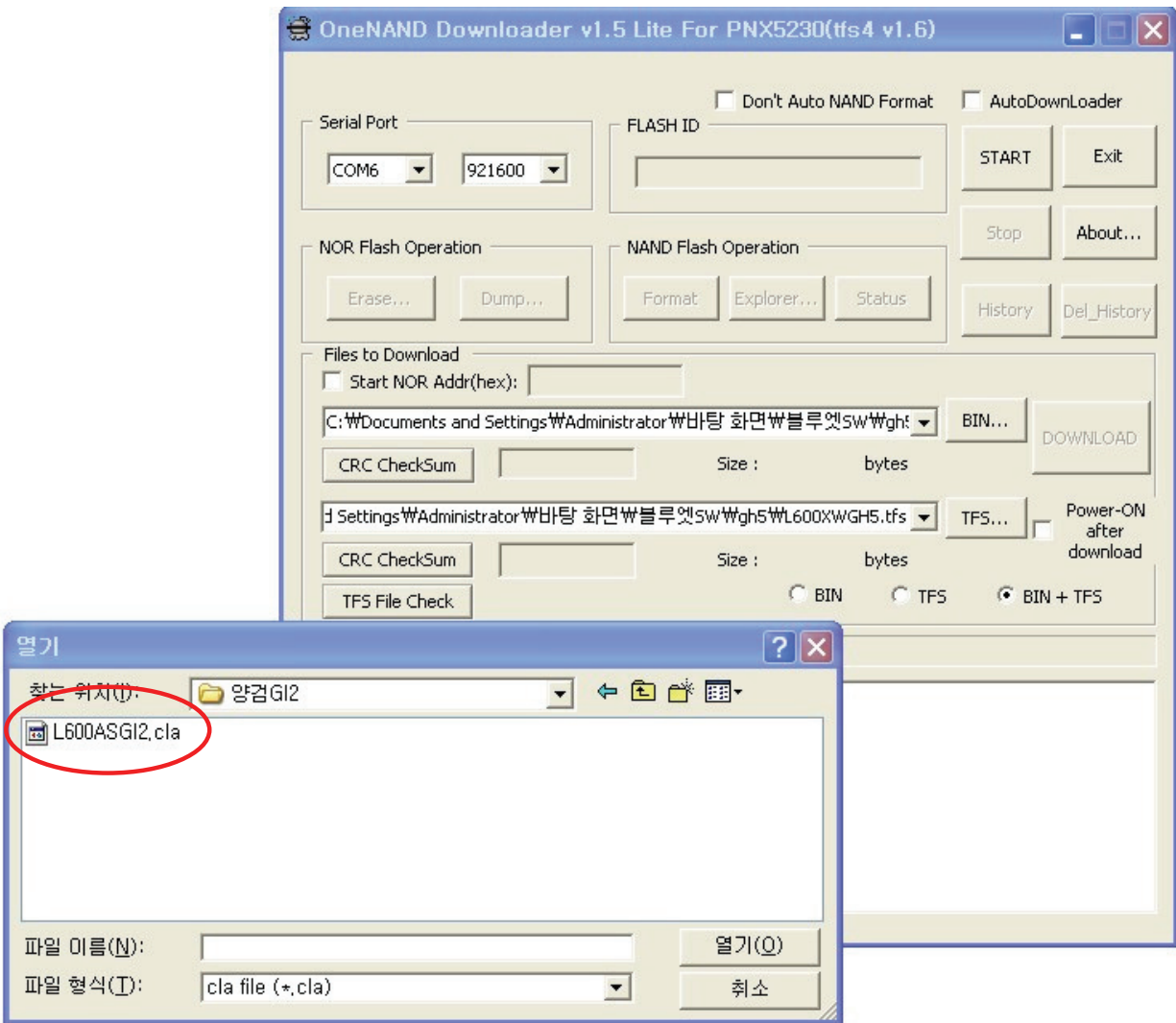

7. Block Diagrams

7-1. RF Solution Block Diagram

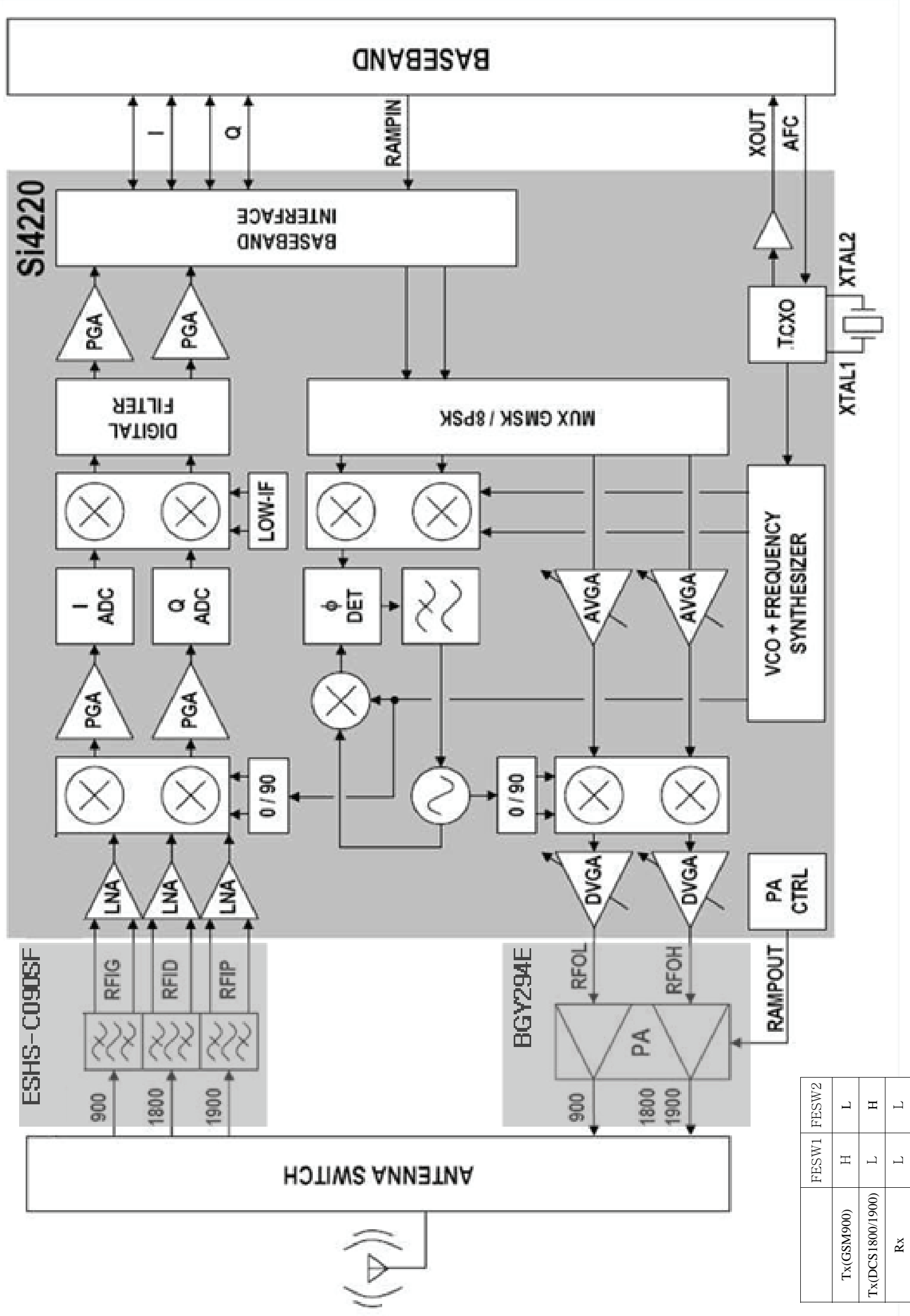

7-2. BT Solution Block Diagram

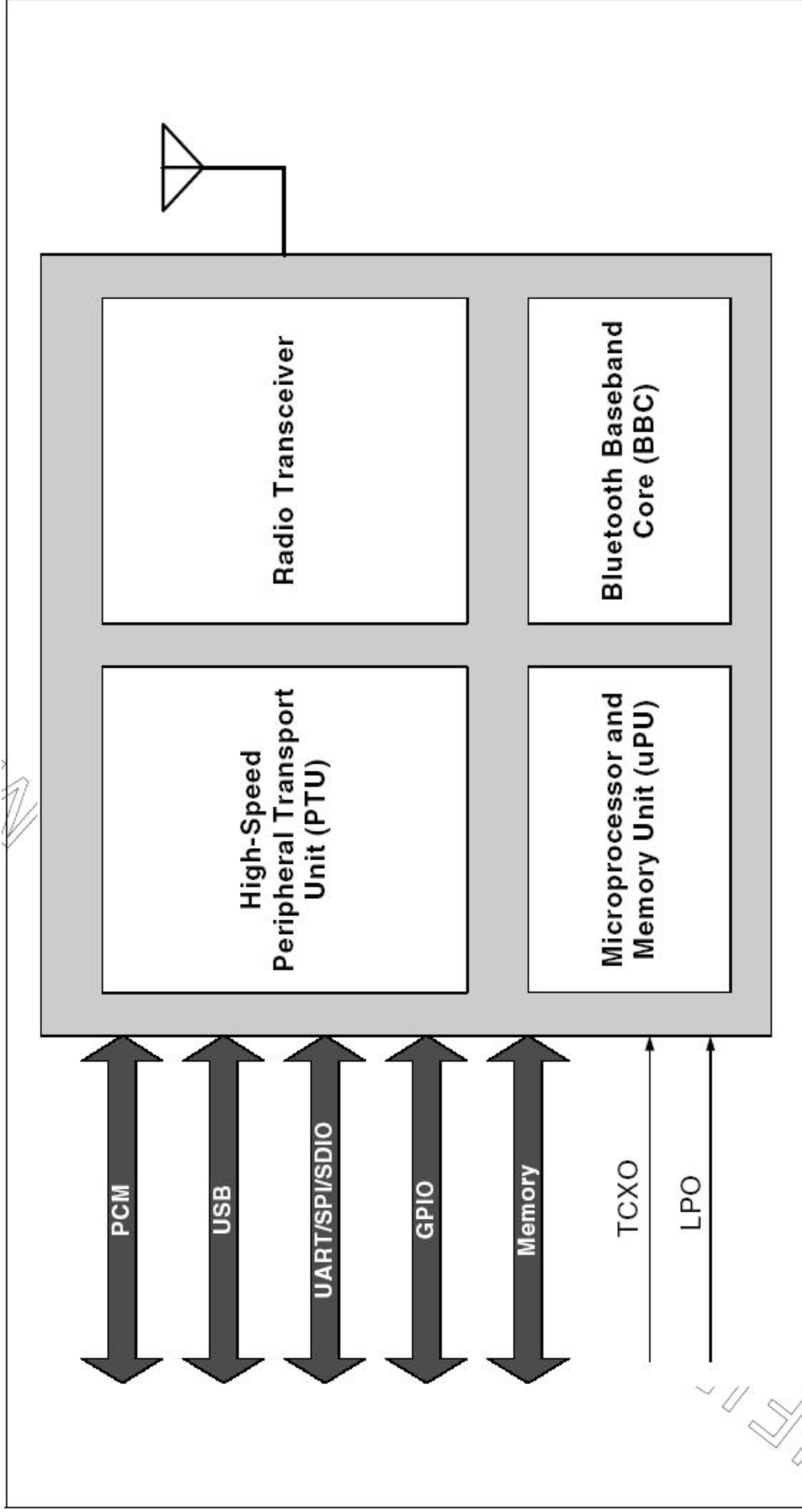

7-3. Base Band Solution Block Diagram

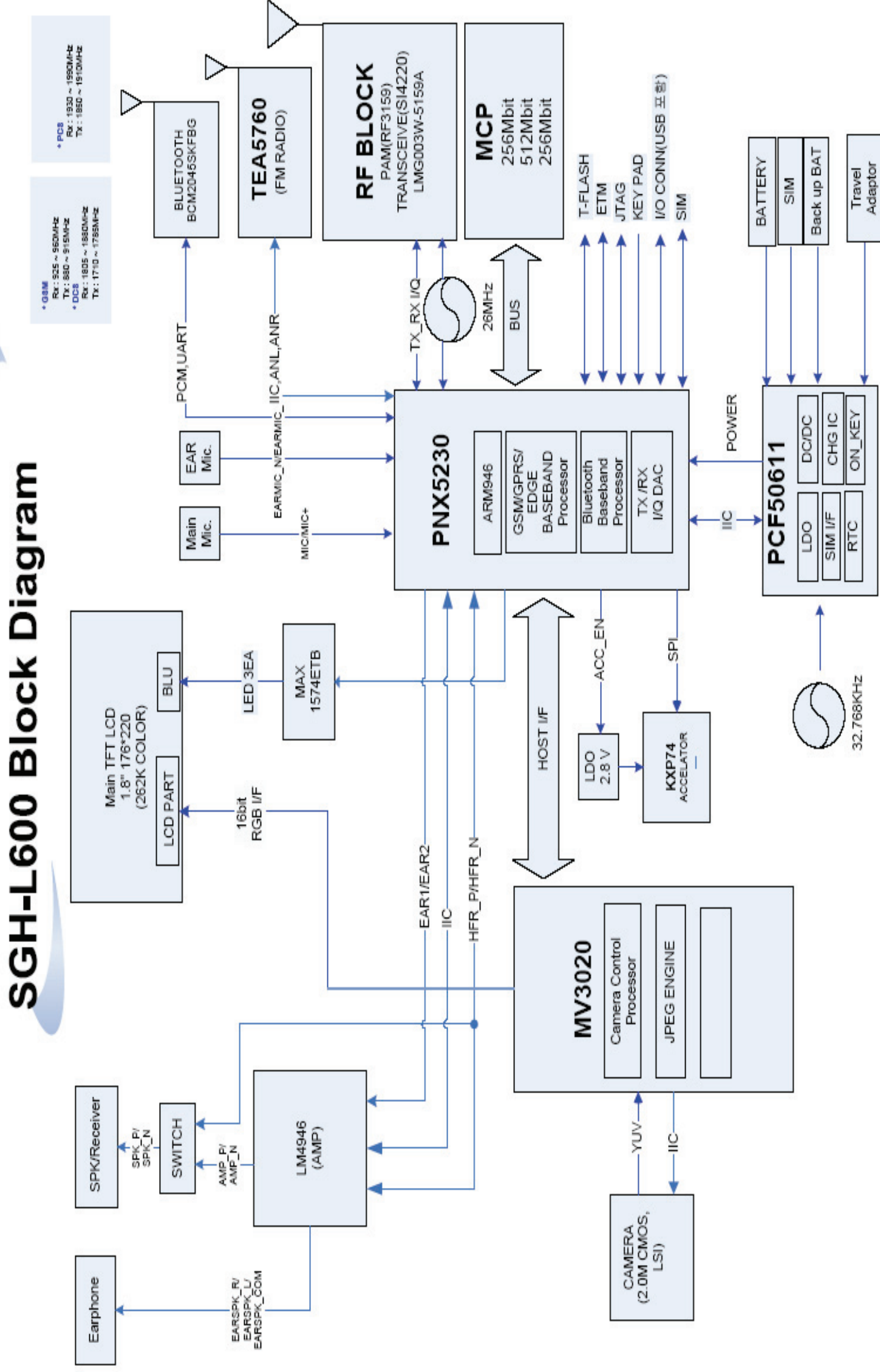

8. PCB Diagrams

Top

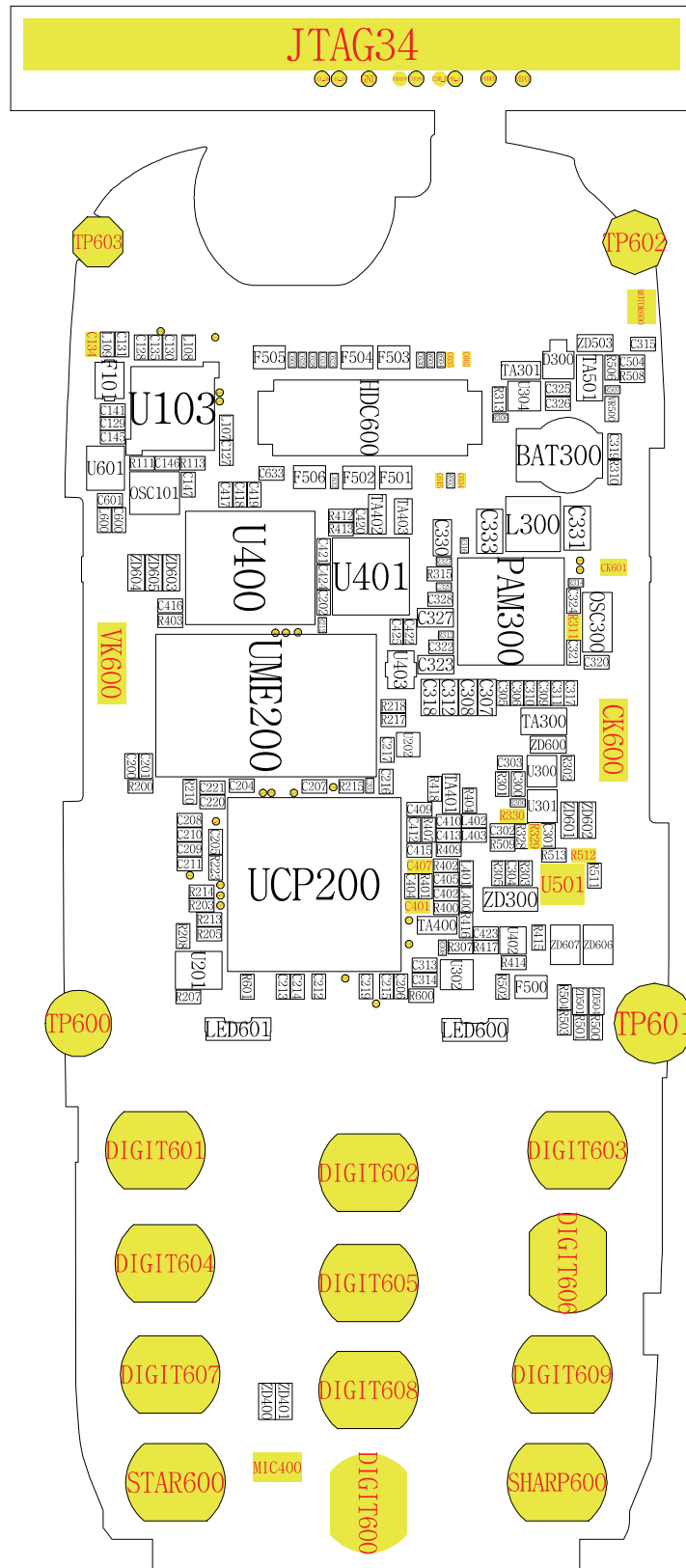

Bottom

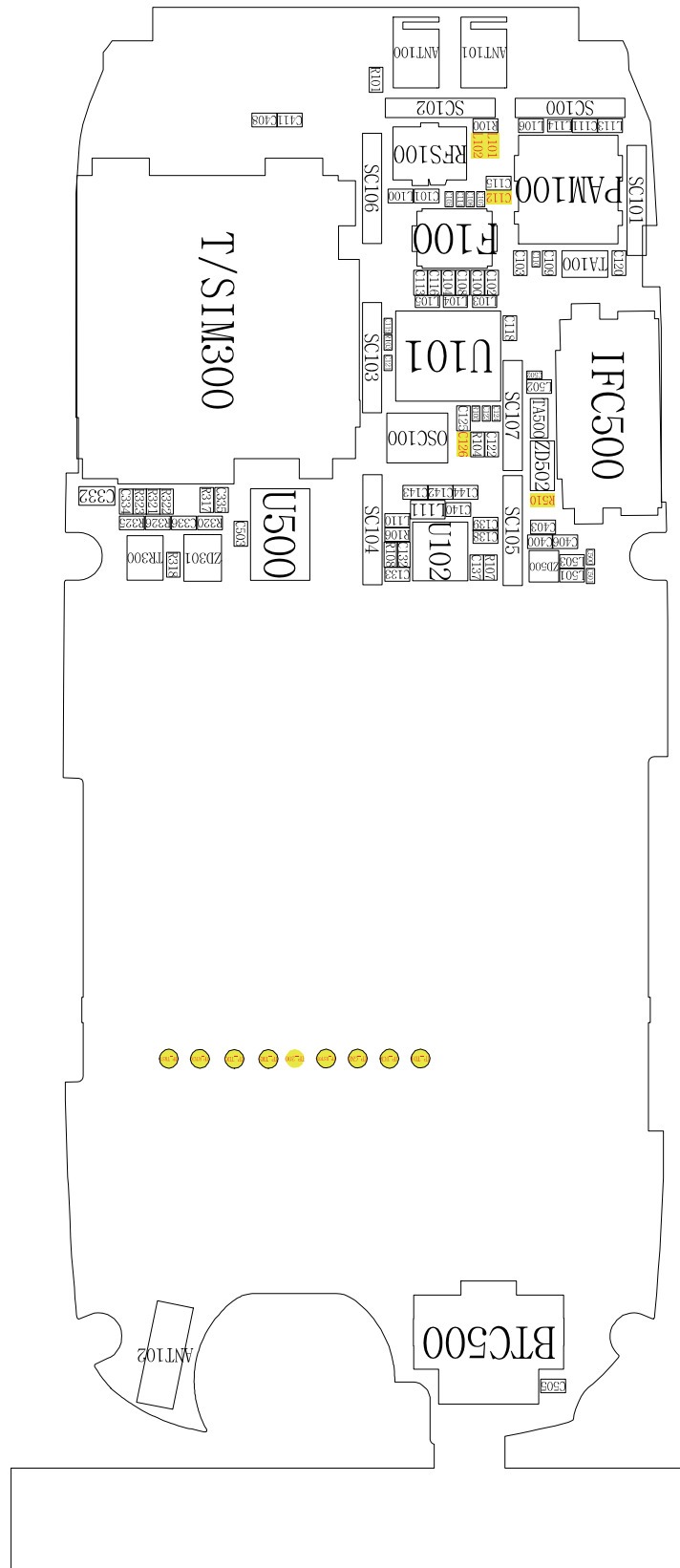

6. MAIN Electrical Parts List

Design LOC	Description	SEC Code	STATUS
ANT100	NPR-ANT CONTACT	GH71-06625A	SA
ANT101	NPR-ANT CONTACT	GH71-06625A	SA
ANT102	ANTENNA-CHIP	4202-001255	SA
BAT300	BATTERY-LI(2ND)	4302-001181	SA
BTC500	HEADER-BATTERY	3711-006025	SA
C100	C-CER,CHIP	2203-005288	SA
C101	C-CER,CHIP	2203-000233	SA
C102	C-CER,CHIP	2203-005288	SA
C103	C-CER,CHIP	2203-000278	SA
C104	C-CER,CHIP	2203-005050	SA
C105	C-CER,CHIP	2203-005736	SA
C106	C-CER,CHIP	2203-005736	SA
C107	C-CER,CHIP	2203-005736	SA
C108	C-CER,CHIP	2203-005050	SA
C109	C-CER,CHIP	2203-006562	SA
C110	C-CER,CHIP	2203-005682	SA
C111	C-CER,CHIP	2203-005057	SA
C113	C-CER,CHIP	2203-005288	SA
C114	C-CER,CHIP	2203-005736	SA
C115	C-CER,CHIP	2203-005552	SA
C116	C-CER,CHIP	2203-005288	SA
C118	C-CER,CHIP	2203-000278	SA
C119	C-CER,CHIP	2203-005736	SA
C120	C-CER,CHIP	2203-000812	SA
C121	C-CER,CHIP	2203-006423	SA
C122	C-CER,CHIP	2203-006638	SA
C123	C-CER,CHIP	2203-006423	SA
C124	C-CER,CHIP	2203-006423	SA
C125	C-CER,CHIP	2203-000438	SA
C127	C-CER,CHIP	2203-006048	SA
C128	C-CER,CHIP	2203-000438	SA
C129	C-CER,CHIP	2203-006048	SA
C130	C-CER,CHIP	2203-006838	SA
C131	C-CER,CHIP	2203-002668	SA
C132	C-CER,CHIP	2203-006048	SA
C133	C-CER,CHIP	2203-006562	SA
C135	C-CER,CHIP	2203-006838	SA
C137	C-CER,CHIP	2203-006048	SA
C138	C-CER,CHIP	2203-006260	SA
C139	C-CER,CHIP	2203-006260	SA
C140	C-CER,CHIP	2203-006048	SA
C141	C-CER,CHIP	2203-000278	SA
C142	C-CER,CHIP	2203-000995	SA
C143	C-CER,CHIP	2203-000679	SA
C144	C-CER,CHIP	2203-000359	SA
C145	C-CER,CHIP	2203-006842	SA
C146	C-CER,CHIP	2203-000278	SA
C147	C-CER,CHIP	2203-000278	SA
C200	C-CER,CHIP	2203-006399	SA
C201	C-CER,CHIP	2203-005482	SA
C202	C-CER,CHIP	2203-005482	SA
C203	C-CER,CHIP	2203-006123	SA
C204	C-CER,CHIP	2203-005482	SA

Design LOC	Description	SEC Code	STATUS
C205	C-CER,CHIP	2203-005482	SA
C206	C-CER,CHIP	2203-000679	SA
C207	C-CER,CHIP	2203-005482	SA
C208	C-CER,CHIP	2203-005450	SA
C209	C-CER,CHIP	2203-000679	SA
C210	C-CER,CHIP	2203-005482	SA
C211	C-CER,CHIP	2203-005482	SA
C212	C-CER,CHIP	2203-005482	SA
C213	C-CER,CHIP	2203-005450	SA
C214	C-CER,CHIP	2203-000679	SA
C215	C-CER,CHIP	2203-005482	SA
C216	C-CER,CHIP	2203-005482	SA
C217	C-CER,CHIP	2203-006399	SA
C219	C-CER,CHIP	2203-006562	SA
C220	C-CER,CHIP	2203-000425	SA
C221	C-CER,CHIP	2203-000425	SA
C300	C-CER,CHIP	2203-006562	SA
C301	C-CER,CHIP	2203-006562	SA
C302	C-CER,CHIP	2203-006562	SA
C303	C-CER,CHIP	2203-006562	SA
C304	C-CER,CHIP	2203-006048	SA
C305	C-CER,CHIP	2203-006257	SA
C306	C-CER,CHIP	2203-006257	SA
C307	C-CER,CHIP	2203-006208	SA
C308	C-CER,CHIP	2203-006890	SA
C309	C-CER,CHIP	2203-005056	SA
C310	C-CER,CHIP	2203-006562	SA
C311	C-CER,CHIP	2203-006257	SA
C312	C-CER,CHIP	2203-006208	SA
C313	C-CER,CHIP	2203-006562	SA
C314	C-CER,CHIP	2203-006562	SA
C315	C-CER,CHIP	2203-000995	SA
C317	C-CER,CHIP	2203-006257	SA
C318	C-CER,CHIP	2203-006208	SA
C319	C-CER,CHIP	2203-000233	SA
C320	C-CER,CHIP	2203-006257	SA
C321	C-CER,CHIP	2203-000425	SA
C322	C-CER,CHIP	2203-006562	SA
C323	C-CER,CHIP	2203-006348	SA
C324	C-CER,CHIP	2203-000425	SA
C325	C-CER,CHIP	2203-005482	SA
C326	C-CER,CHIP	2203-006562	SA
C327	C-CER,CHIP	2203-006324	SA
C328	C-CER,CHIP	2203-006257	SA
C329	C-CER,CHIP	2203-006423	SA
C330	C-CER,CHIP	2203-006208	SA
C331	C-CER,CHIP	2203-006361	SA
C332	C-CER,CHIP	2203-006824	SA
C333	C-CER,CHIP	2203-006474	SA
C334	C-CER,CHIP	2203-006048	SA
C335	C-CER,CHIP	2203-006562	SA
C336	C-CER,CHIP	2203-000425	SA
C400	C-CER,CHIP	2203-001437	SA

Design LOC	Description	SEC Code	STATUS
C402	C-CER,CHIP	2203-005482	SA
C403	C-CER,CHIP	2203-001072	SA
C404	C-CER,CHIP	2203-000278	SA
C405	C-CER,CHIP	2203-005482	SA
C406	C-CER,CHIP	2203-001437	SA
C408	C-CER,CHIP	2203-000628	SA
C409	C-CER,CHIP	2203-000278	SA
C410	C-CER,CHIP	2203-005482	SA
C411	C-CER,CHIP	2203-000628	SA
C412	C-CER,CHIP	2203-000278	SA
C413	C-CER,CHIP	2203-005482	SA
C415	C-CER,CHIP	2203-000278	SA
C416	C-CER,CHIP	2203-006562	SA
C417	C-CER,CHIP	2203-005482	SA
C418	C-CER,CHIP	2203-005482	SA
C419	C-CER,CHIP	2203-006562	SA
C420	C-CER,CHIP	2203-005482	SA
C421	C-CER,CHIP	2203-006626	SA
C422	C-CER,CHIP	2203-005483	SA
C423	C-CER,CHIP	2203-000233	SA
C424	C-CER,CHIP	2203-006626	SA
C425	C-CER,CHIP	2203-005483	SA
C500	C-CER,CHIP	2203-005779	SA
C501	C-CER,CHIP	2203-005779	SA
C502	C-CER,CHIP	2203-005779	SA
C503	C-CER,CHIP	2203-005482	SA
C504	C-CER,CHIP	2203-005482	SA
C505	C-CER,CHIP	2203-000995	SA
C600	C-CER,CHIP	2203-000438	SA
C601	C-CER,CHIP	2203-002709	SA
C603	C-CER,CHIP	2203-005717	SA
C623	C-CER,CHIP	2203-005717	SA
C628	C-CER,CHIP	2203-005717	SA
C629	C-CER,CHIP	2203-005717	SA
C630	C-CER,CHIP	2203-006423	SA
C631	C-CER,CHIP	2203-005717	SA
C632	C-CER,CHIP	2203-005717	SA
C633	C-CER,CHIP	2203-006562	SA
D300	DIODE-ARRAY	0407-001002	SA
F100	DUPLEXER-FEM	2911-000072	SA
F101	FILTER-LC	2909-001299	SA
F500	FILTER-EMI SMD	2901-001408	SA
F501	FILTER-EMI SMD	2901-001413	SA
F502	FILTER-EMI SMD	2901-001413	SA
F503	FILTER-EMI SMD	2901-001413	SA
F504	FILTER-EMI SMD	2901-001413	SA
F505	FILTER-EMI SMD	2901-001413	SA
F506	FILTER-EMI SMD	2901-001413	SA
HDC600	HEADER-BOARD TO BOARD	3711-005933	SA
IFC500	SOCKET-INTERFACE	3710-002499	SA
L100	INDUCTOR-SMD	2703-002314	SA
L103	INDUCTOR-SMD	2703-002608	SA
L104	INDUCTOR-SMD	2703-002608	SA

Main Electrical Parts List

Design LOC	Description	SEC Code	STATUS
L105	INDUCTOR-SMD	2703-002558	SA
L106	INDUCTOR-SMD	2703-001734	SA
L107	BEAD-SMD	3301-001534	SA
L108	BEAD-SMD	3301-001659	SA
L109	INDUCTOR-SMD	2703-002208	SA
L110	INDUCTOR-SMD	2703-002206	SA
L111	INDUCTOR-SMD	2703-001673	SA
L113	INDUCTOR-SMD	2703-001181	SA
L114	INDUCTOR-SMD	2703-002596	SA
L300	INDUCTOR-SMD	2703-002829	SA
L400	BEAD-SMD	3301-001729	SA
L401	BEAD-SMD	3301-001729	SA
L402	BEAD-SMD	3301-001729	SA
L403	BEAD-SMD	3301-001729	SA
L501	BEAD-SMD	3301-001885	SA
L502	BEAD-SMD	3301-001885	SA
L503	BEAD-SMD	3301-001885	SA
L600	BEAD-SMD	3301-001729	SA
LED600	LED	0601-002268	SA
LED601	LED	0601-002268	SA
OSC100	CRYSTAL-SMD	2801-004426	SA
OSC101	CRYSTAL-SMD	2801-004560	SA
OSC300	CRYSTAL-SMD	2801-004466	SA
PAM100	IC-POWER AMP	1201-002423	SA
PAM300	IC-POWER SUPERVISOR	1203-004382	SA
R100	R-CHIP	2007-000171	SA
R101	R-CHIP	2007-000171	SA
R103	R-CHIP	2007-008419	SA
R104	R-CHIP	2007-001313	SA
R105	R-CHIP	2007-008052	SA
R106	R-CHIP	2007-007308	SA
R107	R-CHIP	2007-003001	SA
R108	R-CHIP	2007-007316	SA
R111	R-CHIP	2007-007489	SA
R113	R-CHIP	2007-007942	SA
R200	R-CHIP	2007-000171	SA
R203	R-CHIP	2007-000148	SA
R205	R-CHIP	2007-000758	SA
R207	R-CHIP	2007-000170	SA
R208	R-CHIP	2007-000170	SA
R210	R-CHIP	2007-000162	SA
R212	R-CHIP	2007-008055	SA
R213	R-CHIP	2007-000758	SA
R214	R-CHIP	2007-000140	SA
R215	R-CHIP	2007-000148	SA
R217	R-CHIP	2007-007137	SA
R218	R-CHIP	2007-007137	SA
R223	R-CHIP	2007-000148	SA
R300	R-CHIP	2007-008055	SA
R301	R-CHIP	2007-000171	SA
R302	R-CHIP	2007-000162	SA
R303	R-CHIP	2007-007573	SA
R305	R-CHIP	2007-008354	SA

Design LOC	Description	SEC Code	STATUS
R306	R-CHIP	2007-009168	SA
R307	R-CHIP	2007-000162	SA
R308	R-CHIP	2007-009168	SA
R310	R-CHIP	2007-000171	SA
R312	R-CHIP	2007-008648	SA
R313	R-CHIP	2007-000162	SA
R314	R-CHIP	2007-008588	SA
R315	R-CHIP	2007-000138	SA
R316	R-CHIP	2007-009314	SA
R317	R-CHIP	2007-000148	SA
R318	R-CHIP	2007-000140	SA
R320	R-CHIP	2007-000159	SA
R321	R-CHIP	2007-000162	SA
R322	R-CHIP	2007-000162	SA
R323	R-CHIP	2007-000162	SA
R325	R-CHIP	2007-000758	SA
R326	R-CHIP	2007-001333	SA
R327	R-CHIP	2007-008055	SA
R328	R-CHIP	2007-000171	SA
R400	R-CHIP	2007-000137	SA
R401	R-CHIP	2007-000148	SA
R402	R-CHIP	2007-000137	SA
R403	R-CHIP	2007-000162	SA
R404	R-CHIP	2007-000137	SA
R407	R-CHIP	2007-000148	SA
R409	R-CHIP	2007-000137	SA
R412	R-CHIP	2007-001288	SA
R413	R-CHIP	2007-001288	SA
R414	R-CHIP	2007-007014	SA
R415	R-CHIP	2007-000138	SA
R416	R-CHIP	2007-000138	SA
R417	R-CHIP	2007-007014	SA
R418	R-CHIP	2007-000138	SA
R500	R-CHIP	2007-001333	SA
R501	R-CHIP	2007-001339	SA
R502	R-CHIP	2007-001333	SA
R503	R-CHIP	2007-007142	SA
R504	R-CHIP	2007-007334	SA
R506	R-CHIP	2007-007142	SA
R507	R-CHIP	2007-009157	SA
R508	R-CHIP	2007-007312	SA
R509	R-CHIP	2007-000171	SA
R511	R-CHIP	2007-000171	SA
R513	R-CHIP	2007-000162	SA
R600	R-CHIP	2007-001284	SA
R601	R-CHIP	2007-001284	SA
R602	R-CHIP	2007-009168	SA
R603	R-CHIP	2007-009112	SNA
R604	R-CHIP	2007-008055	SA
RFS100	CONNECTOR-COAXIAL	3705-001421	SA
SC100	ICT SHIELD-CAN CLIP	GH70-02640A	SA
SC101	ICT SHIELD-CAN CLIP	GH70-02640A	SA
SC102	ICT SHIELD-CAN CLIP	GH70-02640A	SA

Design LOC	Description	SEC Code	STATUS
SC103	ICT SHIELD-CAN CLIP	GH70-02640A	SA
SC104	ICT SHIELD-CAN CLIP	GH70-02640A	SA
SC105	ICT SHIELD-CAN CLIP	GH70-02640A	SA
SC106	ICT SHIELD-CAN CLIP	GH70-02640A	SA
SC107	ICT SHIELD-CAN CLIP	GH70-02640A	SA
T/SIM300	CONNECTOR-CARD EDGE	3709-001453	SA
TA100	C-TA,CHIP	2404-001496	SA
TA300	C-TA,CHIP	2404-001430	SA
TA301	C-TA,CHIP	2404-001381	SA
TA400	C-TA,CHIP	2404-001377	SA
TA401	C-TA,CHIP	2404-001377	SA
TA402	C-TA,CHIP	2404-001381	SA
TA403	C-TA,CHIP	2404-001226	SA
TA500	C-TA,CHIP	2404-001381	SA
TA501	C-TA,CHIP	2404-001430	SA
TR300	FET-SILICON	0505-002111	SA
U101	IC-TRANSCIEVER	1205-003093	SA
U102	IC-DEMODULATOR	1204-002688	SA
U103	IC-TRANSCIEVER	1205-002942	SA
U201	FILTER-EMI SMD	2901-001316	SA
U202	IC-CMOS LOGIC	0801-003022	SA
U300	IC-POSI.FIXED REG.	1203-003523	SA
U301	IC-POSI.FIXED REG.	1203-003737	SA
U302	IC-POSI.FIXED REG.	1203-003737	SA
U304	IC-POSI.FIXED REG.	1203-003737	SA
U400	IC ASIC	GH13-00032A	SA
U401	IC-AUDIO AMP	1201-002492	SA
U402	IC-CMOS LOGIC	0801-003079	SA
U403	IC-ANALOG MULTIPLEX	1001-001447	SA
U500	IC-SENSOR	1209-001774	SA
U601	IC-HALL EFFECT S/W	1009-001020	SA
UCP200	IC-COMM. CONTROLLER	1205-003082	SA
UME200	IC-MCP	1108-000102	SA
VR500	THERMISTOR-NTC	1404-001221	SA
ZD300	DIODE-ZENER	0403-001547	SA
ZD301	DIODE-TVS	0406-001200	SA
ZD400	DIODE-TVS	0406-001201	SA
ZD401	DIODE-TVS	0406-001201	SA
ZD500	DIODE-TVS	0406-001215	SA
ZD501	DIODE-TVS	0406-001254	SA
ZD502	DIODE-ZENER	0403-001339	SA
ZD503	DIODE-TVS	0406-001150	SA
ZD504	DIODE-TVS	0406-001254	SA
ZD600	DIODE-TVS	0406-001201	SA
ZD601	DIODE-TVS	0406-001201	SA
ZD602	DIODE-TVS	0406-001201	SA
ZD603	DIODE-TVS	0406-001201	SA
ZD604	DIODE-TVS	0406-001201	SA
ZD605	DIODE-TVS	0406-001201	SA
ZD606	DIODE-TVS	0406-001208	SA
ZD607	DIODE-TVS	0406-001208	SA

Please consult the GSPN website (Samsung Portal) for the most recent version of the product's part list.

3. Product Function

Main Function

- GPRS/EDGE Class10
- 2 Megapixel Camera
- 262K Color TFT QCIF Screen (1.8" 176x220)
- Video Recording & Messaging
- Mp3, AAC, AAC+, WMA
- USB 2.0
- Bluetooth V2.0 EDR
- Multimedia Message Service (MMS)
- External Memory
- Java / WAP2.0
- Tri-band(900/1800/1900MHz)
- FM Radio
- Stereo / Speaker Phone

10. Reference data

Reference Abbreviate

- **AAC**: Advanced Audio Coding.
- **AVC** : Advanced Video Coding.
- **BER** : Bit Error Rate
- **BPSK**: Binary Phase Shift Keying
- **CA** : Conditional Access
- **CDM** : Code Division Multiplexing
- **C/I** : Carrier to Interference
- **DMB** : Digital Multimedia Broadcasting
- **EN** : European Standard
- **ES** : Elementary Stream
- **ETSI**: European Telecommunications Standards Institute
- **MPEG**: Moving Picture Experts Group
- **PN** : Pseudo-random Noise
- **PS** : Pilot Symbol
- **QPSK**: Quadrature Phase Shift Keying
- **RS** : Reed-Solomon
- **SI** : Service Information
- **TDM** : Time Division Multiplexing
- **TS** : Transport Stream

1. Safety Precautions

1-1. Repair Precaution

- Repair in Shield Box, during detailed tuning.
Take specially care of tuning or test,
because specipicty of cellular phone is sensitive for surrounding interference(RF noise).
- Be careful to use a kind of magnetic object or tool,
because performance of parts is damaged by the influence of magnetic force.
- Surely use a standard screwdriver when you disassemble this product, otherwise screw
will be worn away.
- Use a thicken twisted wire when you measure level.
A thicken twisted wire has low resistance, therefore error of measurement is few.
- Repair after separate Test Pack and Set because for short danger (for example an
overcurrent and furious flames of parts etc) when you repair board in condition of
connecting Test Pack and tuning on.
- Take specially care of soldering, because Land of PCB is small and weak in heat.
- Surely tune on/off while using AC power plug, because a repair of battery charger is
dangerous when tuning ON/OFF PBA and Connector after disassembling charger.
- Don't use as you pleases after change other material than replacement registered on SEC
System.
Otherwise engineer in charge isn't charged with problem that you don't keep this rules.

1-2. ESD(Electrostatically Sensitive Devices) Precaution

Several semiconductor may be damaged easily by static electricity. Such parts are called by ESD(Electrostatically Sensitive Devices), for example IC,BGA chip etc. Read Precaution below. You can prevent from ESD damage by static electricity.

- Remove static electricity remained your body before you touch semiconductor or parts with semiconductor. There are ways that you touch an earthed place or wear static electricity prevention string on wrist.
- Use earthed soldering steel when you connect or disconnect ESD.
- Use soldering removing tool to break static electricity. , otherwise ESD will be damaged by static electricity.
- Don't unpack until you set up ESD on product. Because most of ESD are packed by box and aluminum plate to have conductive power,they are prevented from static electricity.
- You must maintain electric contact between ESD and place due to be set up until ESD is connected completely to the proper place or a circuit board.