

SAMSUNG

GSM TELEPHONE

SGH-X810

SERVICE *Manual*

GSM TELEPHONE



CONTENTS

1. Safety Precautions
2. Specification
3. Product Function
4. Array course control
5. Exploded View and Parts List
6. MAIN Electrical Parts List
7. Block Diagrams
8. PCB Diagrams
9. Flow Chart of Troubleshooting
10. Reference data

**SAMSUNG
ELECTRONICS**



목 차

1. Safety Precautions

- 1-1. Repair Precaution1-1
- 1-2. ESD(Electrostatically Sensitive Devices) Precaution1-2

2. Specification

- 2-1. GSM General Specification2-1
- 2-2. GSM Tx Power Class2-2

3. Product Function

- 3-1. Main Function3-1

4. Array course control

Software Downloading

- 4-1. Downloading Binary Files4-2
- 4-2. Pre-requisite for Downloading4-2
- 4-3. S/W Downloader Program4-3

5. Exploded View and Parts List

- 5-1. Cellular phone Exploded View5-1
- 5-2. Cellular phone Part list5-2
- 5-3. Cellular phone Exploded View5-4
- 5-4. Cellular phone assembling5-7
- 5-5. Slide FPCB KIT assembling5-15

6. MAIN Electrical Parts List

7. Block Diagrams

8. PCB Diagrams

- 8-1. Main8-1
- 8-2. LCD8-3

9. Flow Chart of Troubleshooting

- 9-1. Baseband
 - 9-1-1. Power ON9-1
-

목 차

9-1-2. Initial	9-4
9-1-3. Sim Part	9-6
9-1-4. Charging Part	9-8
9-1-5. Microphone Part	9-10
9-1-6. Speaker Part	9-12
9-1-7. LCD	9-15
9-1-8. Camera	9-17
9-2. RF	
9-2-1. GSM Receiver.....	9-19
9-2-2. DCS Receiver.....	9-20
9-2-3. PCS Receiver.....	9-21
9-2-4. GSM Transmitter.....	9-23
9-2-5. DCS Transmitter.....	9-24
9-2-6. PCS Transmitter.....	9-25
9-2-7. Bluetooth Part	9-27

10. Reference data

1. Safety Precautions

1-1. Repair Precaution

- Repair in Shield Box, during detailed tuning.
Take specially care of tuning or test,
because specipicty of cellular phone is sensitive for surrounding interference(RF noise).
- Be careful to use a kind of magnetic object or tool,
because performance of parts is damaged by the influence of manetic force.
- Surely use a standard screwdriver when you disassemble this product,
otherwise screw will be worn away.
- Use a thicken twisted wire when you measure level.
A thicken twisted wire has low resistance, therefore error of measurement is few.
- Repair after separate Test Pack and Set because for short danger (for example an
overcurrent and furious flames of parts etc) when you repair board in condition of
connecting Test Pack and tuning on.
- Take specially care of soldering, because Land of PCB is small and weak in heat.
- Surely tune on/off while using AC power plug, because a repair of battery charger is
dangerous when tuning ON/OFF PBA and Connector after disassembling charger.
- Don't use as you pleases after change other material than replacement registered on SEC System.
Otherwise engineer in charge isn't charged with problem that you don't keep this rules.

1-2. ESD(Electrostatically Sensitive Devices) Precaution

Several semiconductor may be damaged easily by static electricity. Such parts are called by ESD (Electrostatically Sensitive Devices), for example IC,BGA chip etc. Read Precaution below. You can prevent from ESD damage by static electricity.

- Remove static electricity remained your body before you touch semiconductor or parts with semiconductor. There are ways that you touch an earthed place or wear static electricity prevention string on wrist.
- Use earthed soldering steel when you connect or disconnect ESD.
- Use soldering removing tool to break static electricity. , otherwise ESD will be damaged by static electricity.
- Don't unpack until you set up ESD on product. Because most of ESD are packed by box and aluminum plate to have conductive power,they are prevented from static electricity.
- You must maintain electric contact between ESD and place due to be set up until ESD is connected completely to the proper place or a circuit board.

2. Specification

2-1. GSM General Specification

	GSM900 Phase 1	EGSM 900 Phase 2	DCS1800 Phase 1	PCS1900
Freq. Band[MHz] Uplink/Downlink	890~915 935~960	880~915 925~960	1710~1785 1805~1880	1850~1910 1930~1990
ARFCN range	1~124	0~124 & 975~1023	512~885	512~810
Tx/Rx spacing	45MHz	45MHz	95MHz	80MHz
Mod. Bit rate/ Bit Period	270.833kbps 3.692us	270.833kbps 3.692us	270.833kbps 3.692us	270.833kbps 3.692us
Time Slot Period/Frame Period	576.9us 4.615ms	576.9us 4.615ms	576.9us 4.615ms	576.9us 4.615ms
Modulation	0.3GMSK	0.3GMSK	0.3GMSK	0.3GMSK
MS Power	33dBm~13dBm	33dBm~5dBm	30dBm~0dBm	30dBm~0dBm
Power Class	5pcl ~ 15pcl	5pcl ~ 19pcl	0pcl ~ 15pcl	0pcl ~ 15pcl
Sensitivity	-102dBm	-102dBm	-100dBm	-100dBm
TDMA Mux	8	8	8	8
Cell Radius	35Km	35Km	2Km	-

2-2. GSM Tx Power Class

TX Power control level	GSM900	TX Power control level	DCS1800	TX Power control level	PCS1900
5	33±2 dBm	0	30±3 dBm	0	30±3 dBm
6	31±2 dBm	1	28±3 dBm	1	28±3 dBm
7	29±2 dBm	2	26±3 dBm	2	26±3 dBm
8	27±2 dBm	3	24±3 dBm	3	24±3 dBm
9	25±2 dBm	4	22±3 dBm	4	22±3 dBm
10	23±2 dBm	5	20±3 dBm	5	20±3 dBm
11	21±2 dBm	6	18±3 dBm	6	18±3 dBm
12	19±2 dBm	7	16±3 dBm	7	16±3 dBm
13	17±2 dBm	8	14±3 dBm	8	14±3 dBm
14	15±2 dBm	9	12±4 dBm	9	12±4 dBm
15	13±2 dBm	10	10±4 dBm	10	10±4 dBm
16	11±3 dBm	11	8±4dBm	11	8±4dBm
17	9±3dBm	12	6±4 dBm	12	6±4 dBm
18	7±3 dBm	13	4±4 dBm	13	4±4 dBm
19	5±3 dBm	14	2±5 dBm	14	2±5 dBm
		15	0±5 dBm	15	0±5 dBm

3. Product Function

Main Function

- Camera and camcorder
- Image editor
- MP3 player
- Phonebook
- Name card
- Multimedia Message Service (MMS)
- E-mail
- Voice recorder
- Bluetooth
- Get personal with photo caller ID
- Web browser
- Java
- Calendar

4. Array course control

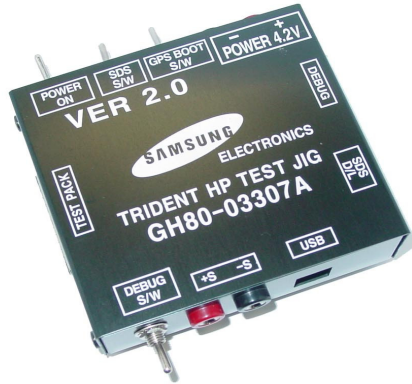

Test Jig (GH80-03307A)



Test Cable (GH39-00127A)



RF Test Cable (GH39-00283A)

Software Downloading

4-1. Downloading Binary Files

- Three binary files for downloading X810.
 - X810XXYY.s3 : Main source code binary.

4-2. Pre-requisite for Downloading

- Downloader Program([OptiFlash.exe](#))
- X810 Mobile Phone
- Data Cable
- Binary files

4-3. S/W Downloader Program

1. Load the binary download program by executing the **"OptiFlash.exe"**



2. Select the **"Options" -> "Settings" -> "Generic" -> "Specify hardware platform"**.

Choose hardware platform for the downloader file setting.

Set the everything else as the default values which are shown below

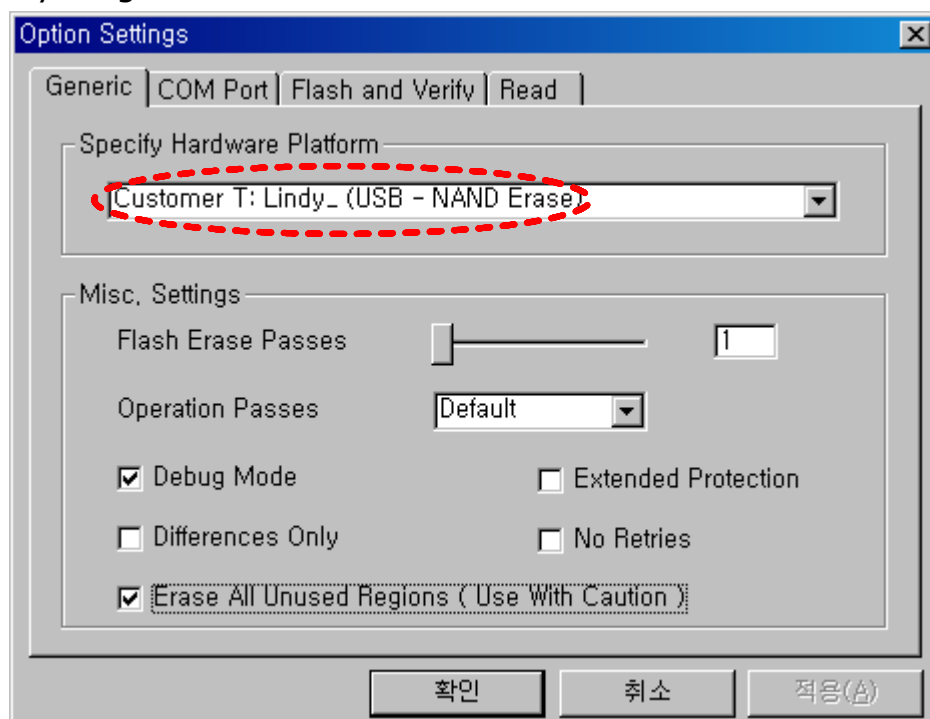

3. Select the **COM port** when the download cable is connected

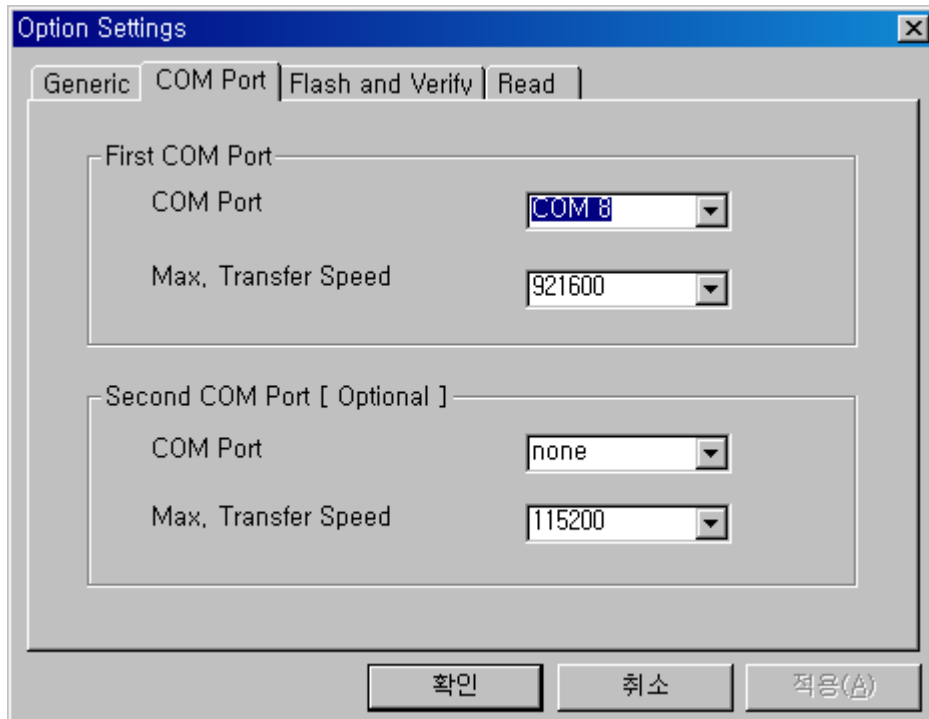

Up to twelve ports are supported. Additionally you can select the maximum transfer speed OptiFlash will use to communicate with the phone. However, OptiFlash will use a slower speed if either the PC's or the phone's serial hardware is incapable of handling the selected speed

4. Select the "**Flash&Verify**" -> "**Browse**"

Set the directory path and choose the latest s/w binary, for example "X810XXYY.s3", for the downloader binary setting.

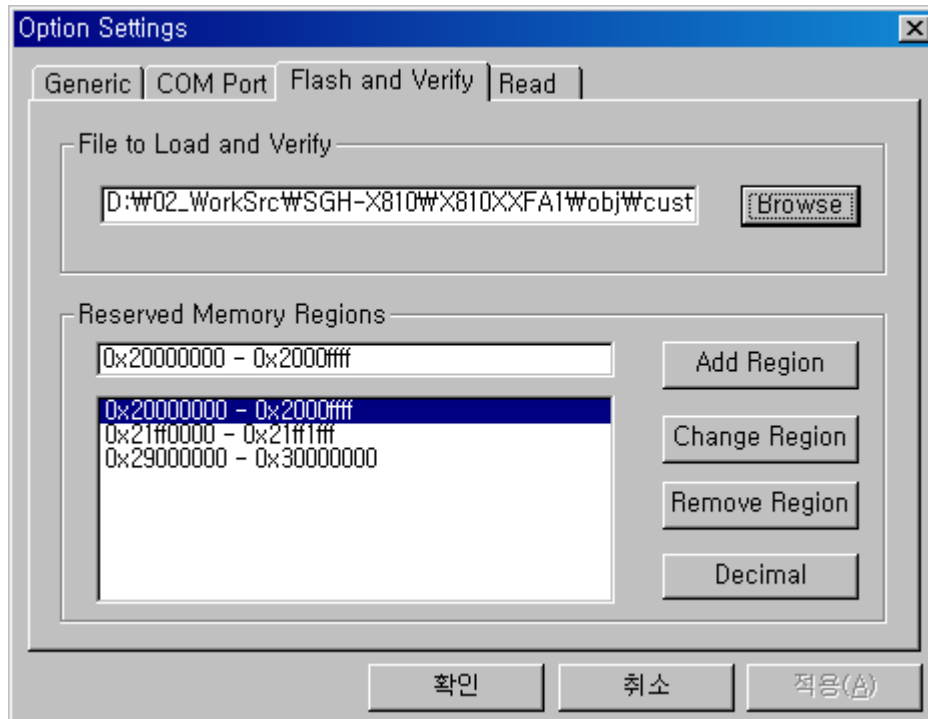

Make sure that not to change the reserved memory regions.

In case of X800 the reserved regions are :

-0x20000000 – 0x2000ffff

-0x21ff0000– 0x21ff1fff

-0x29000000 – 0x30000000

- Click "OK" button then press "Flash".
(Before pressing 'Flash' button, push the button '*' and 'END' at the same time. Then press 'Flash'.)

Downloader will upload the binary file as below for the downloading. 🎵

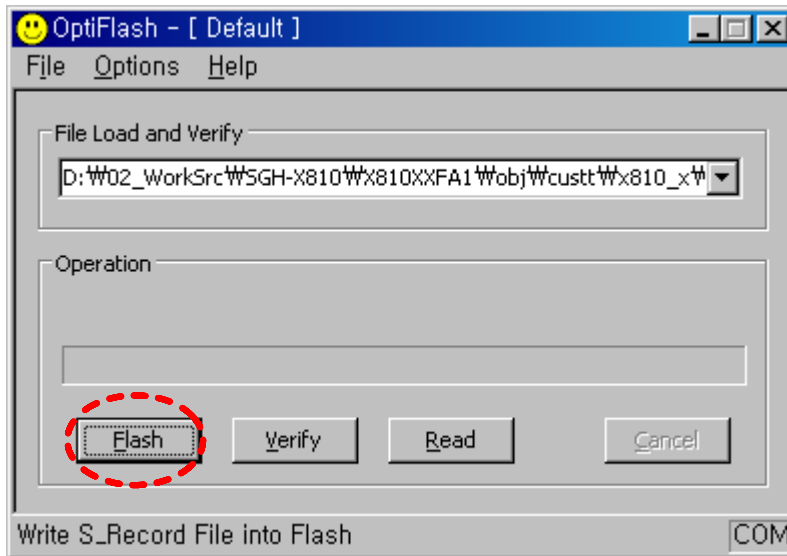

- When downloading is finished successfully, there is a "All is well" message. 🎵
- After finishing downloading, Certain memory resets should be done to guarantee the normal performance. 🎵
- Confirm the downloaded version name and etc. : 🎵

***#5002*8376263#** 🎵

Full Reset : 🎵

***2767*3855#**

5. Exploded View and Parts List

5-1. Cellular phone Exploded View

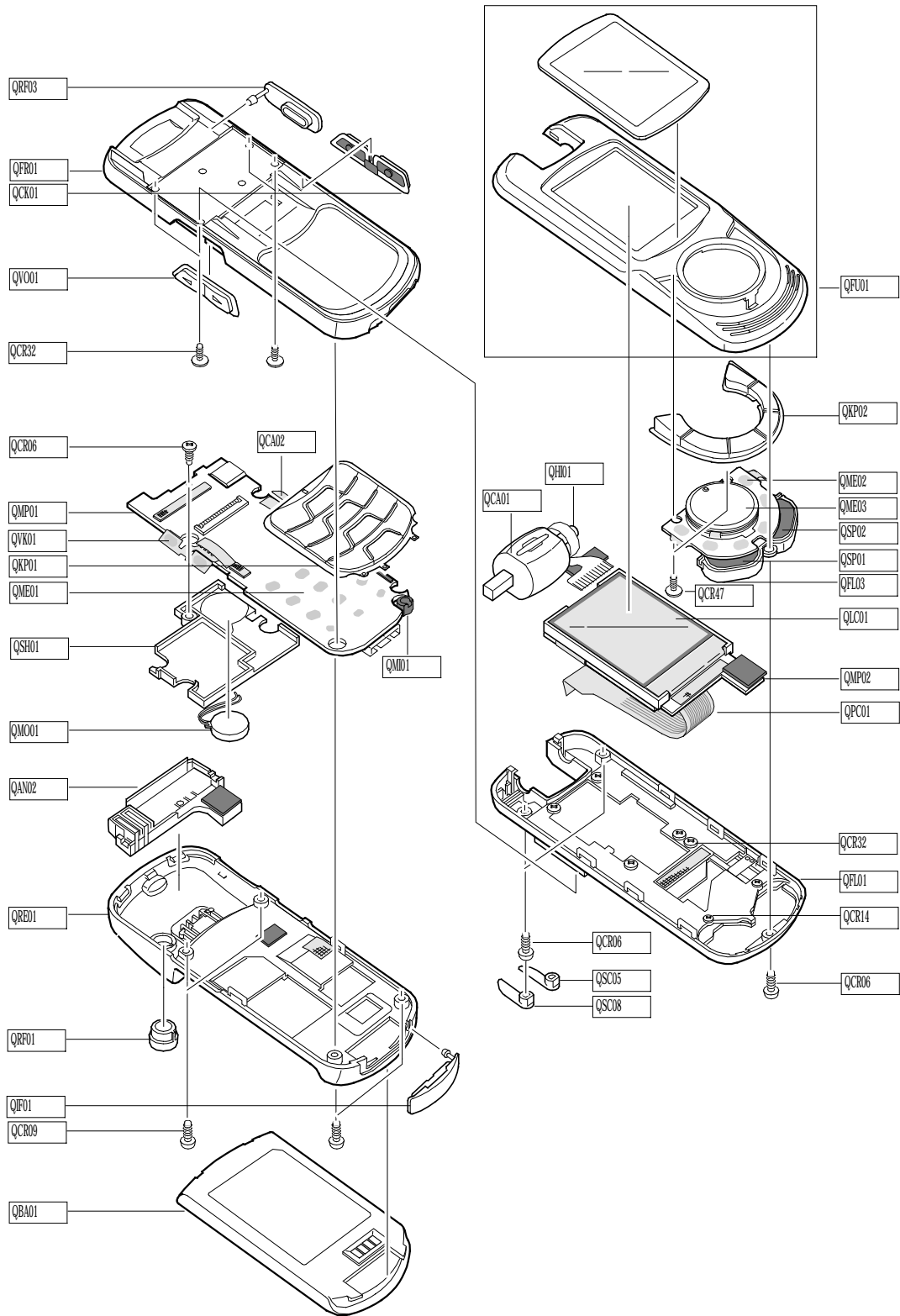







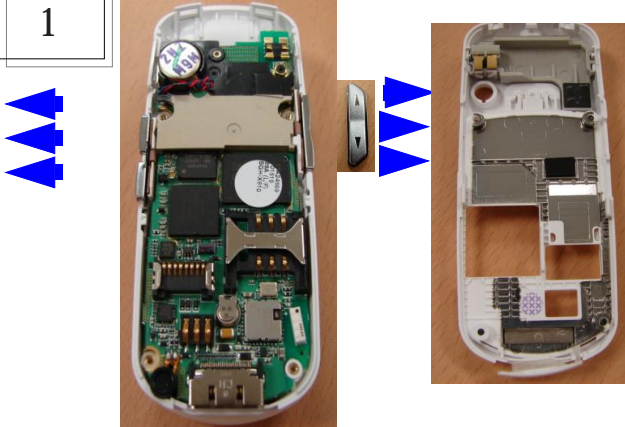

5-2. Cellular phone Parts list

Design LOC	Discription	SEC Code	
QAN02	INTENNA-SGHX810	GH42-00675A	
QBA01	BATTERY-800MAH, WHITE, EU, M	GH43-02042A	
QCA01	UNIT-CAMERA	GH59-02104B	
QCA02	UNIT-CAMERA KEY	GH59-02381A	
QCK01	MEC-CAMERA KEY	GH75-07163A	
QCR06	SCREW-MACHINE	6001-001155	
QCR06	SCREW-MACHINE	6001-001155	
QCR09	SCREW-MACHINE	6001-001670	
QCR32	SCREW-MACHINE	6001-001700	
QCR47	SCREW-MACHINE	6001-001695	
QFL03	PMO-SLIDE KEY BRACKET	GH72-28604A	
QFU01	MEC-SLIDE UPPER SUB	GH75-07335A	
QHI01	MEC-HINGE(CAMERA)	GH75-06936A	
QKP01	MEC-KEYPAD(SER/RUSS)	GH75-08151A	
QKP02	MEC-KEYPAD SUB	GH75-07165A	
QLC01	LCD-SGHX810	GH07-00818A	
QME01	UNIT-METAL DOME	GH59-02382A	
QME02	UNIT-KEY FPCB	GH59-02769A	
QME03	UNIT-JOG KEY	GH59-02063A	
QMI01	MICROPHONE-ASSY-SCHS380	GH30-00189A	
QMO01	MOTOR DC-SGHX810	GH31-00190A	
QMP01	PBA MAIN-SGHX810	GH92-02177A	
QMP02	PBA SUB-SGHX810 LCD	GH92-02231A	
QPC01	MEA-SLIDE FPCB KIT	GH97-05420A	
QRF01	PMO-RF COVER	GH72-21648B	
QSC05	PMO-SLIDE LOWER BUSH L	GH72-22302B	
QSC08	PMO-SLIDE LOWER BUSH R	GH72-22303B	
QSH01	MEC-SHIELD COVER	GH75-07453A	
QSP01	SPEAKER	3001-001885	
QSP02	SPEAKER	3001-001876	
QVK01	UNIT-VOLUME KEY	GH59-02380A	
QVO01	MEC-KEY VOLUME	GH75-06934A	
QRE01	MEC-REAR COVER	GH75-07162A	
	QIF01	PMO-IF COVER	GH72-23824A
QFR01		MEC-FRONT COVER	GH75-07159A
	QRF03	PMO-EAR COVER	GH72-21642B
	QFL01	MEC-S/LOWER HINGE	GH75-07160A
	QCR14	SCREW-MACHINE	6001-001648
	QCR32	SCREW-MACHINE	6001-001700

Discription	SEC Code
BAG PE	6902-000297
CBF INTERFACE-PC DATA CABLE	GH39-00404A
CHARGER-SGHE880 TC	GH44-00861A
S/W CD-X810 PC STUDIO 3.0	GH46-00199A
UNIT-EARPHONE	GH59-02320B
LABEL(P)-WATER SOAK	GH68-02026A
LABEL(P)-WATER SOAK	GH68-02026A
MANUAL-WARRANTY CARD	GH68-02623A
MANUAL-SFC	GH68-04336A
MANUAL-USER	GH68-07940A
LABEL(R)-MAIN(SER)	GH68-08176B
LABEL(P)-BARCODE RUSSIA	GH68-08494A
BOX(P)-UNIT MAIN(SER)	GH69-03274B
CUSHION-CASE TA2 MANUAL2	GH69-03316A
MPR-VINYL BOHO UPPER A	GH74-15083C
MPR-INTENNA PORON	GH74-17166A
MPR-PCB SHIELD SPONGE	GH74-17187A
MPR-TAPE LCD CON MASK	GH74-18421A
MPR-TAPE LCD B2B CONMASK	GH74-18422A
MPR-TAPE LCD HOLE MASK	GH74-18423A
MPR-TAPE CAM CON MASK	GH74-18424A
MPR-CAM FPCB GASKET	GH74-18425A
MPR-TAPE MAIN B2B CON	GH74-18590A
MPR-SIDE KEY GASKET	GH74-18687A
MPR-TAPE VOL KEY MASK	GH74-18688A
MPR-TAPE DOME SHORT	GH74-18689A
MPR-TAPE LCD SHORT	GH74-19768A
MPR-LOWER CONTACT GASKET	GH74-19769A
MPR-TAPE MAIN PCB GND	GH74-19770A
MPR-TAPE SUB KEY GND	GH74-19771A
MPR-TAPE SUB KEY MASK	GH74-19772A
MPR-LIGHT PORON A	GH74-20133A
MPR-LIGHT PORON B	GH74-20134A
MPR-TAPE JOG KEY MASK	GH74-20135A
MPR-LCD PORON	GH74-20566A
MPR-VINYL BOHO REAR	GH74-20788A
MPR-BT GASKET	GH74-20864A
MEC-ANT CONTACT RUBBER	GH75-05947A

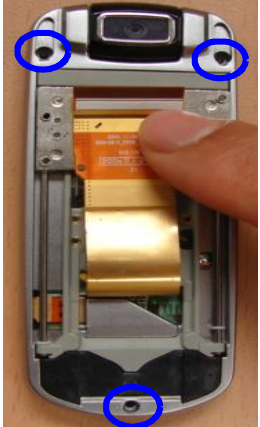
5-3. Cellular phone Exploded View

<div style="border: 1px solid black; padding: 5px; width: 40px; text-align: center; margin-bottom: 10px;">1</div> 	<div style="border: 1px solid black; padding: 5px; width: 40px; text-align: center; margin-bottom: 10px;">2</div> 
<div style="border: 1px solid black; padding: 5px;"> <ol style="list-style-type: none"> 1) Unscrew. 2) Remove the camera key and the volume key from the PBA. 3) Remove the camera FPCB and the volume key FPCB from the surface of the wall. </div>	<div style="border: 1px solid black; padding: 5px;"> <ol style="list-style-type: none"> 1) Remove the dome short tape with tweezers. 2) Remove main b2b con mask tape with tweezers. </div>
<ol style="list-style-type: none"> 1) When you dismantle a mobile phone, be careful about the warp of the framework or damage of the hook. 2) Be careful about the tear of the camera and the volume key FPCB. 	<ol style="list-style-type: none"> 1) When you remove the tape, Be careful drop of a conduction of electricity thrum. 2) When you use tweezers, be careful a damage of component.
<div style="border: 1px solid black; padding: 5px; width: 40px; text-align: center; margin-bottom: 10px;">3</div>  <div style="border: 1px solid black; padding: 5px; margin-top: 10px;"> <ol style="list-style-type: none"> 1) Open the actuator. 2) Pull out the FPCB carefully. </div>	<div style="border: 1px solid black; padding: 5px; width: 40px; text-align: center; margin-bottom: 10px;">4</div> <div style="border: 1px solid black; padding: 5px; margin-top: 10px;"> <ol style="list-style-type: none"> 1) Remove the key pad. 2) Unscrew 4 points using a screwdriver. 3) Separate the front </div> <div style="text-align: right; margin-top: 20px;">  </div>
<ol style="list-style-type: none"> 1) Be careful about the damage of the connector. 	<ol style="list-style-type: none"> 1) Watch out not to come off a waveguide rubber, when you remove the key pad.

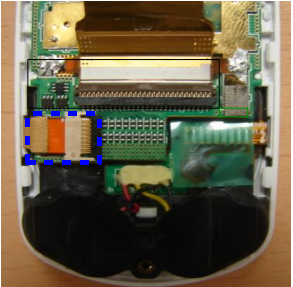
<p>5</p>  <p>1) Lift the slide. 2) Remove the slide lower bush using tweezers. Red circle: dismantling point</p>	<p>6</p>  <p>1) Remove the poron from the slide lower. 2) Unscrew 3 points using a screwdriver.</p>
<p>1) Be careful not to be scratched framework when you dismantle.</p>	
<p>7</p>  <p>1) Disjoint rear cover along blue line using a disassemble stick.</p>	<p>8</p>  <p>1) Remove the camera FPCB gasket with tweezers. 2) Remove the camera connector tape with tweezers.</p>
<p>1) When you dismantle a mobile phone, beware of the warp of the framework and damage of the hook.</p>	<p>1) When you use tweezers, pay attention not to damage parts.</p>
<p>9</p>  <p>1) Open the camera actuator. 2) Disjoint camera hinge in the camera module. 3) Disjoint camera module in the camera connector.</p>	<p>10</p>  <p>1) Take off the sub key mask tape with tweezers. 2) Disjoint the slide key connector. 3) Disjoint the LCD assay. 4) Attach the protect vinyl on the LCD.</p>
<p>1) Beware of the connector.</p>	<p>1) Beware of the connector.</p>

11

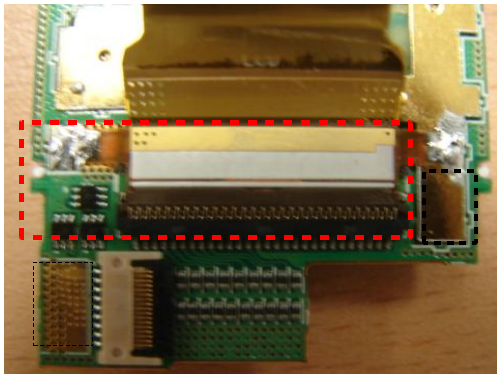

1) Remove the LCD B2B CON mask tape with tweezers.

1) When you use tweezers, pay attention not to damage parts.

12

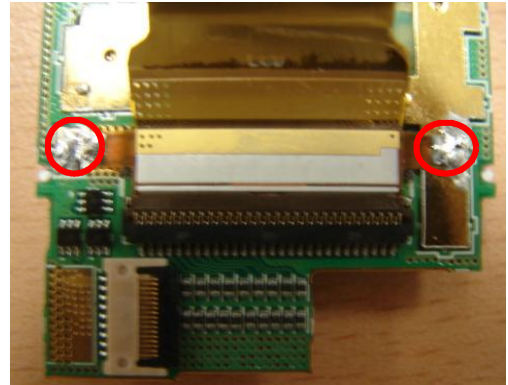

1) Unsolder the B2B FPCB from the LCD PBA.
2) Open the actuator.
3) Disjoint the LCD FPCB from the LCD main connector.

1) Beware of the connector.

13



1) Take off the LCD connector masking tape with tweezers.
2) Open the actuator.
3) Disjoint the LCD FPCB from the LCD connector.

1) Pay attention to damage of the connector.
2) Pay attention to tear of the FPCB.

5-4. Cellular phone assembling

1

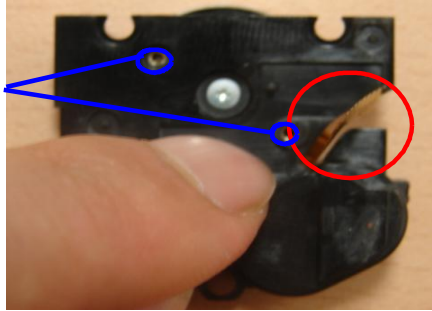

1) Screw on a JOG.

1) Pull the F-PCB of JOG through the gap of KEY BRACKET.

2



1) Put the SPEAKER WIRE through the hole of KEY BRACKET marked in red circle.

1) Check the color of SPEAKER WIRE.

3

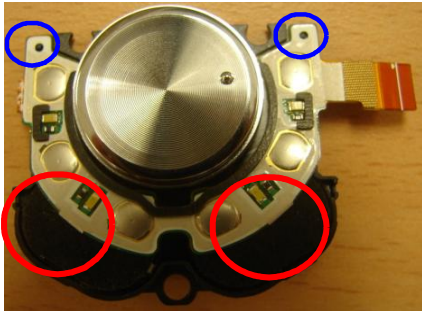

- 1) Remove the paper on the back of SLIDE KEY F-PCB.
- 2) Adhere the SLIDE KEY F-PCB to SLIDE KEY BRACKET from GUIDE PIN marked in blue circle.
- 3) Take care of the GUIDE HOLE of SLIDE KEY F-PCB adhering on the GUIDE PIN of KEY BRACKET front.
- 4) Press the marked part in red circle of SLIDE KEY FPCB with thomb to stick to SPKEAR.

1) Take care of the PORON on SLIDE KEY F-PCB not to be pressed.

4

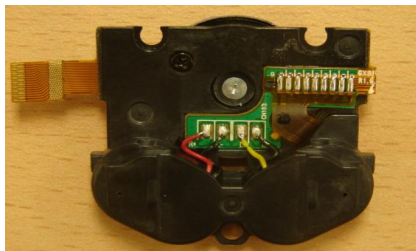

- 1) Solder the JOG KEY F-PCB after positioning it on the GUIDE PIN.
- 2) Solder the SPEAKER WIRE using pinset.

1) Take care of soldering correct.

5

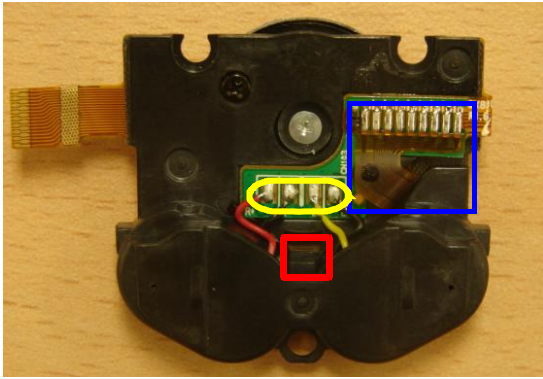

- 1) Open the SPK WIRE using pinset not to position in the square marked in red.
- 2) Bond the soldered part marked in yellow circle all together.
- 3) Adhere the JOG KEY MASK TAPE in the square marked in blue to cover the soldered part.

- 1) Do not bond too much and control the amount of bond not to be high.
- 2) Take care of the TAPE not to be twisted..

6

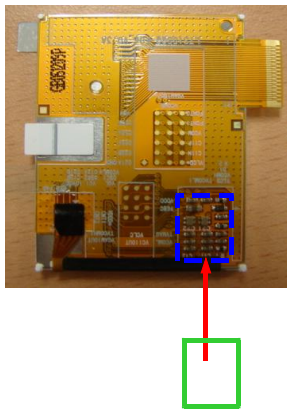

- 1) Adhere the LCD PCB SHORT TAPE along the silk line.
- 2) Adhere the LCD HOLE MASKING TAPE along the silk line using pinset.

- 1) Take care of TAPES not to be twisted.

7

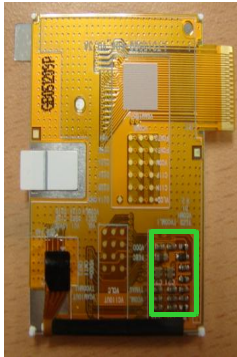

- 1) Insert the LCD F-PCB to the CONNECTOR along the LCD F-PCB silk line.
- 2) Press the ACTUATOR of CONNECTOR.
- 3) Remove the white paper and vinyl paper on the back of LCD.
- 4) Adhere the LCD to LCD PCB with 4 fixing LCD POLES.
- 5) Adhere the LCD CONNECTOR MASKING TAPE using pinset from the left end of ONNECTOR.

1) After inserting CONNECTOR and adhering TAPE, rub evenly.

8

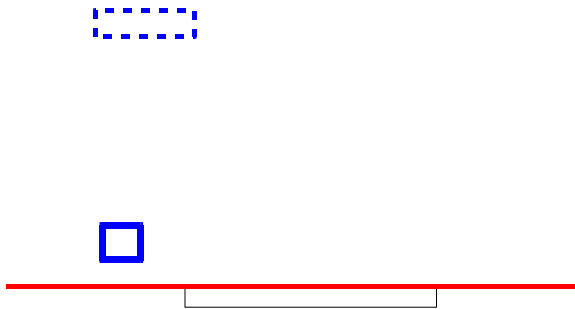

- 1) Adhere the CAM FPCB GASKET along the gold-plated line of PCB left top using pinset .
- 2) Adhere the PCB SHIELD SPONGE along the silk line marked in red line using pinset.
- 3) Adhere the LCD PORON on the left metal plate from left top side.

1) Keep being shown the white slik line after adhering PCB SHIELD SPONGE.

9

Forded
the line

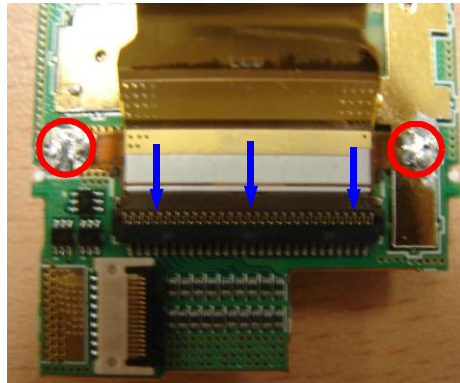

- 1) Fold the FPCB at the end of GND.
- 2) Open the ACTUATOR.
- 3) Remove the paper on the back of SHIELD SPONGE.
- 4) Insert the LCD F-PCB connection part which has soldering wings to the LCD_MAIN CONNECTOR.
- 5) Close the ACTUATOR by pressing with proper finger strength.
- 6) Solder the both sides of F-PCB wing.

- 1) Press the ACTUATOR of CONNECTOR not to make a gap.

10

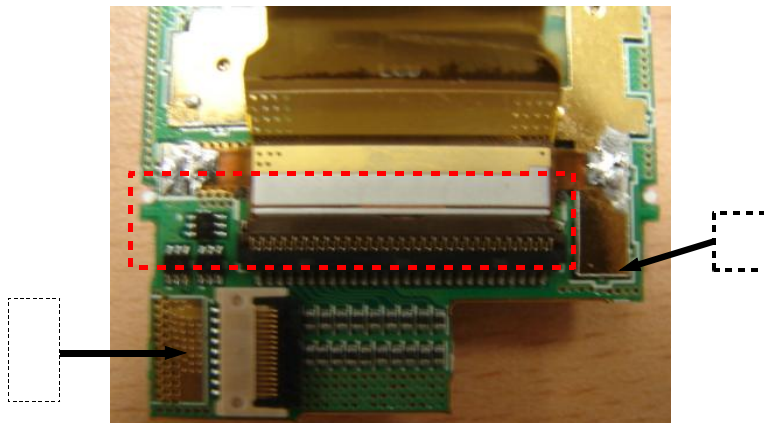

- 1) Adhere the LCD B2B CON MASK TAPE from the right end of CONNECTOR.
- 2) Adhere the LOWER CONTACT GASKET from the bottom silk line.
- 3) Adhere the SUB KEY GND TAPE on the left gold-plated part and position it as far as you can from the connector.

- 1) Rub the taped part evenly after adhering.
- 2) Keep being shown the white slik line after adhering SUB KEY GND TAPE.

11

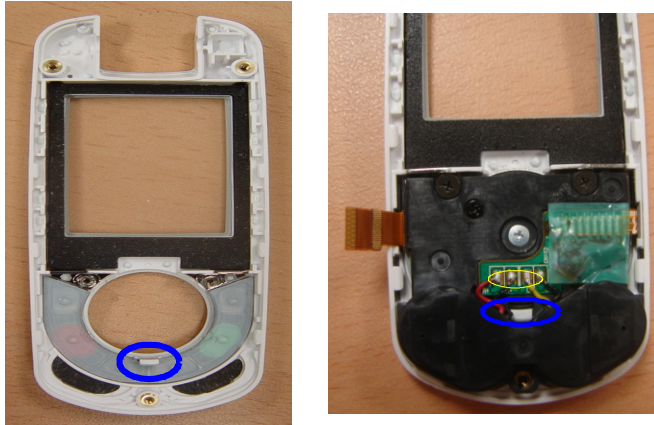

- 1) Put the SLIDE KEY on the SLIDE UPPER like above photo.
- 2) Raise the RIB of FRONT slightly by pushing it from front side.
- 3) Insert the JOG on the FRONT with coming out the RIB through the JOG hole.

12

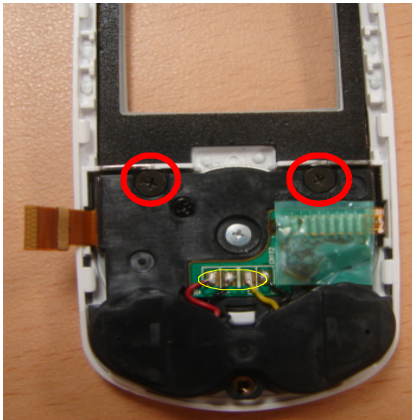

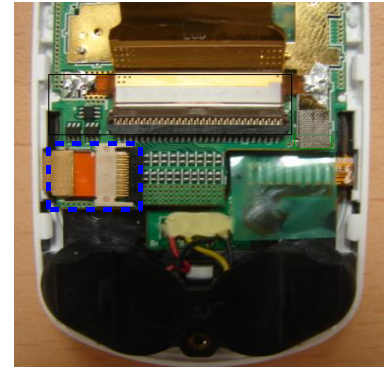

- 1) Screw 2 points marked in red circle.

13

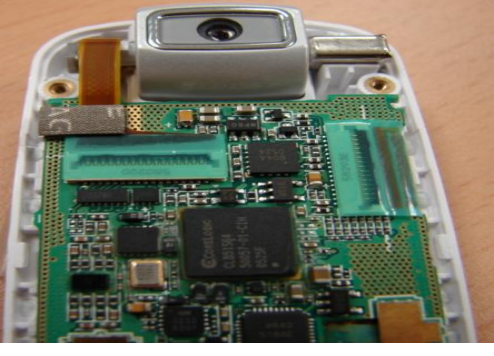
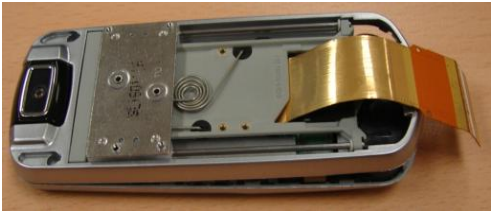

- 1) Remove LCD Protection Film.
- 2) Put LCD down on the Upper structure.
- 3) Remove release paper of Sub Key GND Tape.
- 4) Combine slide key with connector.
- 5) Put on SUB KEY MASK TAPE.

- 1) When Combine SLIDE KEY with CONNECTOR, Be careful move Fixed TAPE
- 2) Attach tape by base line.
- 3) After attach TAPE, Press tape

<div data-bbox="175 243 285 323" style="border: 1px solid black; padding: 2px; width: fit-content; margin-bottom: 10px;">14</div> <div data-bbox="329 243 773 596" style="text-align: center;">  </div> <div data-bbox="168 617 792 835" style="border: 1px solid black; padding: 5px;"> <ol style="list-style-type: none"> 1) Combine Camera connector with camera module. 2) Combine Camera HINGE with Camera module 3) Camera be Rotated two times and Put Camera on SLIDE UPPER. </div>	<div data-bbox="836 243 946 323" style="border: 1px solid black; padding: 2px; width: fit-content; margin-bottom: 10px;">15</div> <div data-bbox="967 243 1458 596" style="text-align: center;">  </div> <div data-bbox="829 617 1458 714" style="border: 1px solid black; padding: 5px;"> <ol style="list-style-type: none"> 1) Put on Camera connector tape. 2) Put GASKET on attached GASKET. </div>
<ol style="list-style-type: none"> 1) Insert Camera FPCB in the Connector. (By Silk Base Line) 2) Camera be rotated surely two times. 	<ol style="list-style-type: none"> 1) Put on CAMERA CONNECTOR TAPE and Press Tape. 2) Put GASKET on attached GASKET.
<div data-bbox="175 1129 285 1209" style="border: 1px solid black; padding: 2px; width: fit-content; margin-bottom: 10px;">16</div> <div data-bbox="306 1129 794 1339" style="text-align: center;">  </div> <div data-bbox="162 1360 802 1499" style="border: 1px solid black; padding: 5px;"> <ol style="list-style-type: none"> 1) F-PCB pass through a SLIDE LOWER. 2) Combine SLIDE UPPER with SLIDE LOWER. (All sides must be locked) </div>	<div data-bbox="836 1129 946 1209" style="border: 1px solid black; padding: 2px; width: fit-content; margin-bottom: 10px;">17</div> <div data-bbox="1170 1129 1378 1486" style="text-align: center;">  </div> <div data-bbox="899 1436 1159 1486" style="border: 1px solid black; padding: 5px; margin-top: 10px;"> <ol style="list-style-type: none"> 1) Screw down. </div>
<ol style="list-style-type: none"> 11) FPCB must be located in Center. 	

<div data-bbox="170 247 284 325" style="border: 1px solid black; padding: 5px; width: fit-content;">18</div> <div data-bbox="354 241 706 730" style="text-align: center;"> </div> <div data-bbox="170 756 787 856" style="border: 1px solid black; padding: 5px;"> <p>1) Put PORON on SLIDE LOWER Structure. 2) Press PORON.</p> </div>	<div data-bbox="836 247 950 325" style="border: 1px solid black; padding: 5px; width: fit-content;">19</div> <div data-bbox="1015 241 1442 640" style="text-align: center;"> </div> <div data-bbox="860 667 1429 856" style="border: 1px solid black; padding: 5px;"> <p>1) Remove SLIDE LOWER BUSH Release Paper 2) Put on SLIDE LOWER BUSH. 3) Press SLIDE LOWER BUSH.</p> </div>
<p>1) Put FPCB on and Check to see both side of PORON.</p>	<p>1)Right & Left SLIDE LOWER BUSH. (Caution of Direction)</p>

<div data-bbox="170 1087 284 1165" style="border: 1px solid black; padding: 5px; width: fit-content;">20</div> <div data-bbox="581 1155 787 1249" style="text-align: center;"> </div> <div data-bbox="162 1360 560 1459" style="border: 1px solid black; padding: 5px;"> <p>1) Put on FRONT Structure and Screw Down.</p> </div>	<div data-bbox="836 1087 950 1165" style="border: 1px solid black; padding: 5px; width: fit-content;">21</div> <div data-bbox="1291 1291 1421 1470" style="text-align: center;"> </div> <div data-bbox="836 1360 1226 1459" style="border: 1px solid black; padding: 5px;"> <p>1) Combine KEY PAD with Front Structure.</p> </div>
--	--

22

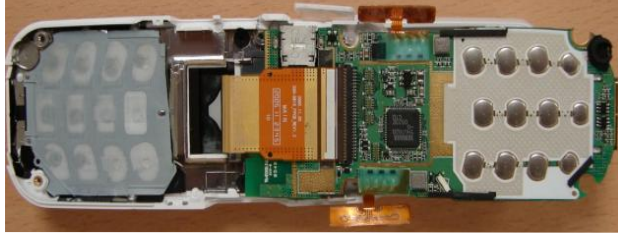

- 1) Insert F-PCB in CONNECTOR (By base line)
- 2) After Connector Locker locked, press Locker of CONNECTOR.

- 1) When insert FPCB in connector, be careful sticking of both side TAPE
- 2) Please be careful damage to connector

23

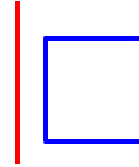

- 1) Attach MAIN B2B CON MASK TAPE by white silk base line.
- 2) Press tape.

- 1) Tape must be covered other parts.
- 2) Press tape.

24

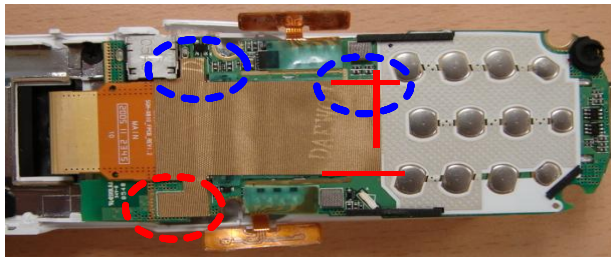

- 1) Put on DOME SHORT TAPE.
- 2) Press TAPE.
- 3) After SLIDE surely closed, Put MAIN PBA on FRONT.
- 4) Attach VOLUME KEY F-PCB & Camera Key F-PCB on FRONT both side

- 1) After SLIDE surely closed, Put MAIN PBA on FRONT.
- 2) When attach TAPE, Be careful Short other parts..

25

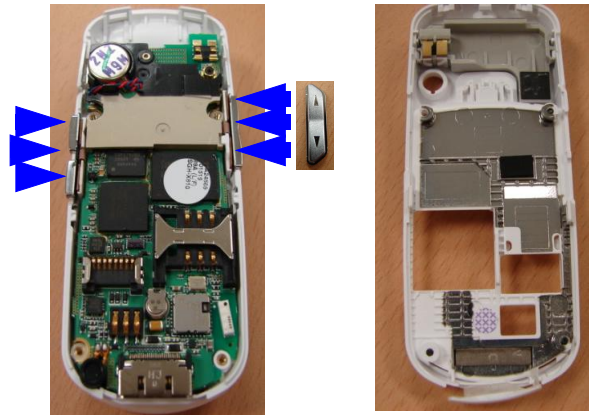

- 1) Put on Camera Key & Volume Key
- 2) Screw Down.

- 1) CAMERA Key & VOLUME Key (Caution of Direction)

5-4. Slide FPCB KIT assembling

1



1) After attach conductivity TAPE for FPCB fixing depending on base line, remove the white paper.
Notice
 When attach, lower SILK line has to be seen

Discription	SEC CODE	SEC Design	quantity
PCB SHIELD SPONGE	GH74-17187A(gray)	DTD-2021, 19 x 3 x 0.4T	1
-	-	-	-

2

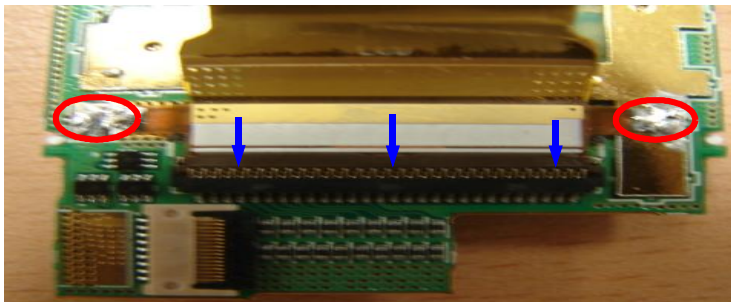

1) Slide FPCB's "LCD" typeface visualizes and inserts to Connector.
 (When insert, PCB's SILK line should be certainly conformable with FPCB's SILK)
 2) After SLIK line agreement confirmation, Presses equally and contracts ACTUATOR.
 3) Solder
Notice : SLIK line agreement confirm certainly.

Discription	SEC CODE	SEC Design	quantity
-	-	-	-

3

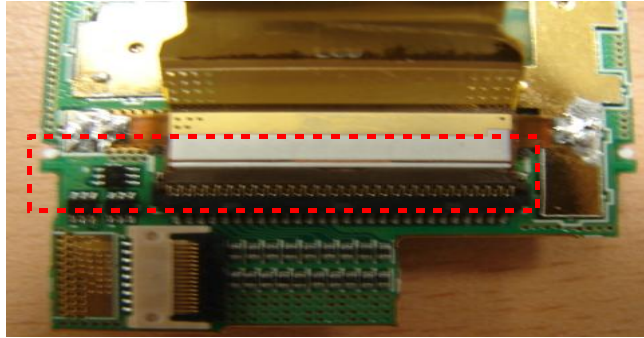

- 1) Attach insulation TAPE on connector via PCB left side..
- 2) Rub by top and bottom, right and left so that can attach perfectly

Notice
That do not swerve.

Discription	SEC CODE	SEC Design	quantity
LCD B2B CON MASK	GH74-18422A(Green)	3M 851, 25 x 7 x 0.08T	1
-	-	-	-

4



- 1) Attach MAIN PCB GND TAPE via the GND PATTERN top portion using tweezers.

Notice
Take care so that other parts and SHORT may not happen.

Discription	SEC CODE	SEC Design	quantity
MAIN PCB GND TAPE	GH74-19770A	DTD-2041, 22 X 3 X 0.4T	1
-	-	-	-

5

- 1) Insert slide that FPCB silk screen "main" is seen
(when we insert FPCB, must be FPCB silk and PCB silk at one)
- 2) After check silks(FPCB silk and PCB silk) that be at one, AXTUATOR down.

Notice

You must check silks(FPCB silk and PCB silk) that be at one.

Discription	SEC CODE	SEC Design	quantity
-	-	-	-

6



- 1) Attach to do horizontality with connetor via white SILK line.

Notice

That do not swerve.

Discription	SEC CODE	SEC Design	quantity
MAIN B2B CON MASK TAPE (green)	GH74-018590A	3M 851, 19.95 X 19.15 X 0.08T	1
-	-	-	-

7



1) Attach DOME SHORT TAPE depending on red base line.

Notice

Take care so that other parts and SHORT may not happen.

Discription	SEC CODE	SEC Design	quantity
DOME SHORT TAPE	GH74-18689A(Gold)	DTF-100, 33.5 X 29.5 X 0.1T	1
-	-	-	-

6. MAIN Electrical Parts List

SEC Code	Ddsign LOC	Discription	STATUS
GH71-04813A	ANT_GND	NPR-ANTENNA CONTACT	SA
GH71-04813A	ANT_SIG	NPR-ANTENNA CONTACT	SA
4202-001111	ANT101	ANTENNA-CHIP	SA
4302-001201	BAT300	BATTERY-LI(2ND)	SA
3711-005781	BTC402	CONNECTOR-BATTERY	SA
2203-000233	C100	C-CER,CHIP	SA
2203-006423	C100	C-CER,CHIP	SA
2203-000233	C101	C-CER,CHIP	SA
2203-005482	C102	C-CER,CHIP	SA
2203-005732	C102	C-CER,CHIP	SA
2203-002668	C103	C-CER,CHIP	SA
2203-006318	C104	C-CER,CHIP	SA
2203-005450	C105	C-CER,CHIP	SA
2203-006318	C106	C-CER,CHIP	SA
2203-006562	C106	C-CER,CHIP	SA
2203-006562	C107	C-CER,CHIP	SA
2203-006846	C107	C-CER,CHIP	SNA
2203-006562	C108	C-CER,CHIP	SA
2203-006846	C108	C-CER,CHIP	SNA
2203-006562	C109	C-CER,CHIP	SA
2203-005682	C111	C-CER,CHIP	SA
2404-001226	C111	C-TA,CHIP	SA
2203-005736	C112	C-CER,CHIP	SA
2203-006838	C113	C-CER,CHIP	SA
2404-001151	C113	C-TA,CHIP	SA
2203-006194	C114	C-CER,CHIP	SA
2404-001402	C114	C-TA,CHIP	SA
2203-005682	C115	C-CER,CHIP	SA
2404-001352	C115	C-TA,CHIP	SA
2203-005792	C116	C-CER,CHIP	SA
2203-006840	C116	C-CER,CHIP	SA
2203-005792	C117	C-CER,CHIP	SA
2203-006399	C118	C-CER,CHIP	SA
2203-000254	C119	C-CER,CHIP	SA
2203-006556	C120	C-CER,CHIP	SA
2203-005682	C121	C-CER,CHIP	SA

SEC Code	Ddsign LOC	Discription	STATUS
2203-006423	C122	C-CER,CHIP	SA
2203-005729	C123	C-CER,CHIP	SA
2203-006305	C124	C-CER,CHIP	SA
2203-006201	C125	C-CER,CHIP	SA
2203-006562	C125	C-CER,CHIP	SA
2203-006562	C126	C-CER,CHIP	SA
2203-006201	C127	C-CER,CHIP	SA
2203-006562	C127	C-CER,CHIP	SA
2203-005482	C128	C-CER,CHIP	SA
2203-006562	C128	C-CER,CHIP	SA
2203-000854	C129	C-CER,CHIP	SA
2203-005061	C130	C-CER,CHIP	SA
2203-006562	C130	C-CER,CHIP	SA
2203-005061	C131	C-CER,CHIP	SA
2203-006648	C131	C-CER,CHIP	SA
2203-005061	C132	C-CER,CHIP	SA
2203-005736	C132	C-CER,CHIP	SA
2203-005736	C133	C-CER,CHIP	SA
2203-006423	C133	C-CER,CHIP	SA
2203-005736	C134	C-CER,CHIP	SA
2203-006423	C134	C-CER,CHIP	SA
2203-005736	C135	C-CER,CHIP	SA
2203-006423	C135	C-CER,CHIP	SA
2203-006194	C136	C-CER,CHIP	SA
2203-006194	C137	C-CER,CHIP	SA
2203-005725	C138	C-CER,CHIP	SA
2203-005736	C139	C-CER,CHIP	SA
2203-005806	C140	C-CER,CHIP	SA
2203-005482	C141	C-CER,CHIP	SA
2203-005792	C145	C-CER,CHIP	SA
2203-006439	C146	C-CER,CHIP	SA
1405-001108	C147	VARISTOR	SA
2203-001437	C148	C-CER,CHIP	SA
2203-006556	C148	C-CER,CHIP	SA
2203-000233	C149	C-CER,CHIP	SA
2203-006556	C149	C-CER,CHIP	SA

SEC Code	Ddsign LOC	Discription	STATUS
2203-006556	C150	C-CER,CHIP	SA
2203-006556	C151	C-CER,CHIP	SA
2203-006556	C152	C-CER,CHIP	SA
2203-006556	C153	C-CER,CHIP	SA
2203-006556	C154	C-CER,CHIP	SA
2203-006556	C155	C-CER,CHIP	SA
2203-006556	C156	C-CER,CHIP	SA
2203-006556	C157	C-CER,CHIP	SA
2203-006556	C158	C-CER,CHIP	SA
2203-006556	C159	C-CER,CHIP	SA
2203-006556	C160	C-CER,CHIP	SA
2203-006556	C161	C-CER,CHIP	SA
2203-006556	C162	C-CER,CHIP	SA
2203-006556	C163	C-CER,CHIP	SA
2203-006562	C164	C-CER,CHIP	SA
2203-006048	C165	C-CER,CHIP	SA
2203-006048	C167	C-CER,CHIP	SA
2203-006048	C168	C-CER,CHIP	SA
2203-006556	C169	C-CER,CHIP	SA
2203-006556	C170	C-CER,CHIP	SA
2203-006556	C171	C-CER,CHIP	SA
2203-006048	C177	C-CER,CHIP	SA
2203-006840	C178	C-CER,CHIP	SA
2203-006840	C179	C-CER,CHIP	SA
2203-006585	C180	C-CER,CHIP	SA
2203-006840	C181	C-CER,CHIP	SA
2203-006585	C182	C-CER,CHIP	SA
2203-006048	C183	C-CER,CHIP	SA
2203-006562	C184	C-CER,CHIP	SA
2203-006562	C185	C-CER,CHIP	SA
2203-006121	C186	C-CER,CHIP	SA
2203-000254	C200	C-CER,CHIP	SA
2203-000254	C201	C-CER,CHIP	SA
2203-006423	C201	C-CER,CHIP	SA
2203-006423	C202	C-CER,CHIP	SA
2203-006562	C202	C-CER,CHIP	SA

SEC Code	Ddsign LOC	Discription	STATUS
2203-006423	C203	C-CER,CHIP	SA
2203-006423	C203	C-CER,CHIP	SA
2203-006423	C204	C-CER,CHIP	SA
2203-006423	C204	C-CER,CHIP	SA
2203-000254	C205	C-CER,CHIP	SA
2203-006361	C205	C-CER,CHIP	SA
2203-006208	C206	C-CER,CHIP	SA
2203-006423	C206	C-CER,CHIP	SA
2203-000254	C207	C-CER,CHIP	SA
2203-006423	C207	C-CER,CHIP	SA
2203-006305	C208	C-CER,CHIP	SA
2203-006423	C208	C-CER,CHIP	SA
2203-006305	C209	C-CER,CHIP	SA
2203-006647	C209	C-CER,CHIP	SA
2203-006423	C210	C-CER,CHIP	SA
2203-005731	C211	C-CER,CHIP	SA
2203-005731	C212	C-CER,CHIP	SA
2203-006423	C213	C-CER,CHIP	SA
2203-006423	C214	C-CER,CHIP	SA
2203-006562	C214	C-CER,CHIP	SA
2203-006194	C215	C-CER,CHIP	SA
2203-006423	C216	C-CER,CHIP	SA
2203-005682	C221	C-CER,CHIP	SA
2203-005682	C223	C-CER,CHIP	SA
2203-006562	C224	C-CER,CHIP	SA
2203-006562	C225	C-CER,CHIP	SA
2404-001339	C226	C-TA,CHIP	SA
2203-006423	C228	C-CER,CHIP	SA
2203-006562	C229	C-CER,CHIP	SA
2203-006423	C230	C-CER,CHIP	SA
2203-006423	C231	C-CER,CHIP	SA
2007-008275	C232	R-CHIP	SA
2007-008275	C233	R-CHIP	SA
2203-006562	C234	C-CER,CHIP	SA
2203-006324	C235	C-CER,CHIP	SA
2203-006423	C236	C-CER,CHIP	SA

SEC Code	Ddsign LOC	Discription	STATUS
2203-006423	C237	C-CER,CHIP	SA
2203-006379	C238	C-CER,CHIP	SA
2404-001381	C239	C-TA,CHIP	SA
2404-001381	C240	C-TA,CHIP	SA
2203-006260	C241	C-CER,CHIP	SA
2203-006260	C242	C-CER,CHIP	SA
2203-006562	C243	C-CER,CHIP	SA
2203-006562	C244	C-CER,CHIP	SA
2203-006194	C300	C-CER,CHIP	SA
2203-006194	C301	C-CER,CHIP	SA
2203-006423	C302	C-CER,CHIP	SA
2203-006423	C303	C-CER,CHIP	SA
2203-006121	C304	C-CER,CHIP	SA
2203-006423	C305	C-CER,CHIP	SA
2203-005682	C306	C-CER,CHIP	SA
2203-005682	C307	C-CER,CHIP	SA
2203-005682	C308	C-CER,CHIP	SA
2203-006201	C309	C-CER,CHIP	SA
2203-006399	C310	C-CER,CHIP	SA
2203-006399	C311	C-CER,CHIP	SA
2203-006399	C312	C-CER,CHIP	SA
2203-006399	C313	C-CER,CHIP	SA
2203-006399	C314	C-CER,CHIP	SA
2203-006399	C315	C-CER,CHIP	SA
2203-005736	C316	C-CER,CHIP	SA
2203-006648	C318	C-CER,CHIP	SA
2203-006423	C320	C-CER,CHIP	SA
2203-006423	C321	C-CER,CHIP	SA
2203-006399	C322	C-CER,CHIP	SA
2203-006399	C323	C-CER,CHIP	SA
2203-006423	C324	C-CER,CHIP	SA
2203-006208	C329	C-CER,CHIP	SA
2203-006399	C330	C-CER,CHIP	SA
2203-006208	C331	C-CER,CHIP	SA
2203-006423	C400	C-CER,CHIP	SA
2203-006053	C401	C-CER,CHIP	SA

SEC Code	Ddsign LOC	Discription	STATUS
2404-001225	C402	C-TA,CHIP	SA
2404-001225	C403	C-TA,CHIP	SA
2203-000854	C404	C-CER,CHIP	SA
2203-000854	C405	C-CER,CHIP	SA
2203-006190	C407	C-CER,CHIP	SA
2203-005682	C409	C-CER,CHIP	SA
2203-000854	C410	C-CER,CHIP	SA
2203-006190	C411	C-CER,CHIP	SA
2203-006423	C412	C-CER,CHIP	SA
2404-001225	C414	C-TA,CHIP	SA
2203-006190	C415	C-CER,CHIP	SA
2203-006423	C416	C-CER,CHIP	SA
2203-000854	C417	C-CER,CHIP	SA
2203-005682	C418	C-CER,CHIP	SA
2203-000386	C419	C-CER,CHIP	SA
2203-000386	C420	C-CER,CHIP	SA
2203-000386	C421	C-CER,CHIP	SA
2203-000386	C422	C-CER,CHIP	SA
2203-006190	C423	C-CER,CHIP	SA
2203-000854	C425	C-CER,CHIP	SA
2203-006648	C426	C-CER,CHIP	SA
2203-005806	C427	C-CER,CHIP	SA
2404-001380	C428	C-TA,CHIP	SA
2404-001380	C429	C-TA,CHIP	SA
2203-006194	C431	C-CER,CHIP	SA
2404-001413	C432	C-TA,CHIP	SA
2404-001225	C433	C-TA,CHIP	SA
2203-006194	C435	C-CER,CHIP	SA
2404-001339	C436	C-TA,CHIP	SA
2203-006648	C437	C-CER,CHIP	SA
2203-000654	C438	C-CER,CHIP	SA
2203-006423	C439	C-CER,CHIP	SA
2203-006423	C440	C-CER,CHIP	SA
2203-006423	C441	C-CER,CHIP	SA
2203-006423	C442	C-CER,CHIP	SA
2203-006668	C444	C-CER,CHIP	SA

SEC Code	Ddsign LOC	Discription	STATUS
2203-006423	C445	C-CER,CHIP	SA
2203-006423	C448	C-CER,CHIP	SA
2203-000854	C449	C-CER,CHIP	SA
2203-006423	C451	C-CER,CHIP	SA
2203-005806	C452	C-CER,CHIP	SA
2404-001225	C453	C-TA,CHIP	SA
2203-006399	C454	C-CER,CHIP	SA
2203-006399	C455	C-CER,CHIP	SA
2203-006423	C506	C-CER,CHIP	SA
2203-006399	C507	C-CER,CHIP	SA
2203-006423	C508	C-CER,CHIP	SA
2404-001394	C509	C-TA,CHIP	SA
2203-006399	C510	C-CER,CHIP	SA
2203-006423	C515	C-CER,CHIP	SA
3709-001381	CD502	CONNECTOR-CARD EDGE	SA
3708-002114	CN101	CONNECTOR-FPC/FFC/PIC	SA
GH71-05778A	CN200	NPR-LCD PLATE L	SA
GH71-05779A	CN201	NPR-LCD PLATE R	SA
2901-001349	D101	FILTER-EMI/ESD	SA
2901-001348	D102	FILTER-EMI/ESD	SA
3722-002175	EAR400	JACK-EAR PHONE	SA
2911-000010	F100	DUPLEXER-FEM	SA
3301-001342	F200	BEAD-SMD	SA
2901-001256	F300	FILTER-EMI SMD	SA
2901-001320	F500	FILTER-EMI/ESD	SA
2901-001320	F501	FILTER-EMI/ESD	SA
2901-001320	F502	FILTER-EMI/ESD	SA
2901-001320	F503	FILTER-EMI/ESD	SA
2901-001361	F504	FILTER-EMI/ESD	SA
2901-001256	F505	FILTER-EMI SMD	SA
3710-002225	IFC401	CONNECTOR-INTERFACE	SA
3301-001729	L100	BEAD-SMD	SA
2703-002586	L101	INDUCTOR-SMD	SA
3301-001729	L101	BEAD-SMD	SA
3301-001729	L102	BEAD-SMD	SA
2703-002636	L103	INDUCTOR-SMD	SA

SEC Code	Ddsign LOC	Discription	STATUS
3301-001729	L104	BEAD-SMD	SA
2703-002558	L105	INDUCTOR-SMD	SA
2703-001876	L108	INDUCTOR-SMD	SA
2703-001722	L110	INDUCTOR-SMD	SA
2703-002798	L111	INDUCTOR-SMD	SNA
2703-002795	L112	INDUCTOR-SMD	SNA
2703-002819	L200	INDUCTOR-SMD	SA
2703-002734	L302	INDUCTOR-SMD	SA
2703-001938	L501	INDUCTOR-SMD	SA
2703-001938	L502	INDUCTOR-SMD	SA
0601-002119	LED308	LED	SA
2801-004426	OSC101	CRYSTAL-SMD	SA
2801-004225	OSC200	CRYSTAL-SMD	SA
2801-004373	OSC200	CRYSTAL-SMD	SA
1201-002223	PAM101	IC-POWER AMP	SA
2007-008483	R100	R-CHIP	SA
2007-008542	R101	R-CHIP	SA
2007-009158	R101	R-CHIP	SA
2007-000162	R103	R-CHIP	SA
2007-008542	R103	R-CHIP	SA
2007-007311	R105	R-CHIP	SA
2007-007134	R108	R-CHIP	SA
2007-007134	R110	R-CHIP	SA
2007-007134	R111	R-CHIP	SA
2007-008263	R112	R-CHIP	SA
2007-008531	R112	R-CHIP	SA
2007-008263	R113	R-CHIP	SA
2007-008516	R113	R-CHIP	SA
2007-008045	R114	R-CHIP	SA
2007-008588	R115	R-CHIP	SA
2007-008587	R116	R-CHIP	SA
2007-008542	R117	R-CHIP	SA
2007-001298	R122	R-CHIP	SA
2007-007488	R133	R-CHIP	SA
2007-009154	R134	R-CHIP	SNA
2007-009154	R135	R-CHIP	SNA

SEC Code	Ddsign LOC	Discription	STATUS
2007-008588	R138	R-CHIP	SA
2007-008419	R139	R-CHIP	SA
2007-008055	R140	R-CHIP	SA
2007-008052	R141	R-CHIP	SA
2007-007311	R142	R-CHIP	SA
2007-007311	R143	R-CHIP	SA
2007-007311	R144	R-CHIP	SA
2007-007311	R145	R-CHIP	SA
2007-007311	R147	R-CHIP	SA
2007-007134	R148	R-CHIP	SA
2007-008588	R200	R-CHIP	SA
2007-008055	R201	R-CHIP	SA
2007-008588	R201	R-CHIP	SA
2007-008483	R202	R-CHIP	SA
2007-008055	R203	R-CHIP	SA
2007-008483	R204	R-CHIP	SA
2007-000162	R205	R-CHIP	SA
2007-009084	R205	R-CHIP	SA
2007-008531	R206	R-CHIP	SA
2007-008647	R207	R-CHIP	SA
2007-008647	R208	R-CHIP	SA
2007-008531	R211	R-CHIP	SA
2007-008531	R214	R-CHIP	SA
2007-008531	R215	R-CHIP	SA
2007-008483	R216	R-CHIP	SA
2007-008483	R217	R-CHIP	SA
2007-008516	R219	R-CHIP	SA
2007-008055	R220	R-CHIP	SA
2007-008210	R221	R-CHIP	SA
2007-008210	R222	R-CHIP	SA
2007-007741	R224	R-CHIP	SA
2007-008579	R225	R-CHIP	SA
2007-008579	R226	R-CHIP	SA
2007-008588	R300	R-CHIP	SA
2007-008052	R304	R-CHIP	SA
2007-008483	R306	R-CHIP	SA

SEC Code	Ddsign LOC	Discription	STATUS
2007-008478	R308	R-CHIP	SA
2007-008420	R311	R-CHIP	SA
2007-008420	R313	R-CHIP	SA
2007-008806	R316	R-CHIP	SA
2007-008806	R317	R-CHIP	SA
2007-008806	R318	R-CHIP	SA
2007-008806	R319	R-CHIP	SA
2007-008806	R320	R-CHIP	SA
2007-008806	R321	R-CHIP	SA
2007-008806	R322	R-CHIP	SA
2007-008806	R323	R-CHIP	SA
2007-008806	R324	R-CHIP	SA
2007-008806	R325	R-CHIP	SA
2007-008806	R326	R-CHIP	SA
2007-001292	R329	R-CHIP	SA
2007-009084	R331	R-CHIP	SA
2007-001298	R333	R-CHIP	SA
2007-001292	R401	R-CHIP	SA
2007-001292	R402	R-CHIP	SA
2007-008055	R403	R-CHIP	SA
2007-007741	R404	R-CHIP	SA
2007-007741	R405	R-CHIP	SA
2007-008055	R406	R-CHIP	SA
2007-008051	R407	R-CHIP	SA
2007-008478	R408	R-CHIP	SA
2007-001119	R409	R-CHIP	SA
2007-008478	R410	R-CHIP	SA
2007-008478	R411	R-CHIP	SA
2007-007741	R412	R-CHIP	SA
2007-008055	R413	R-CHIP	SA
2007-007741	R415	R-CHIP	SA
2007-008055	R416	R-CHIP	SA
2007-009170	R417	R-CHIP	SA
2007-008055	R418	R-CHIP	SA
2007-008419	R419	R-CHIP	SA
2007-008419	R420	R-CHIP	SA

SEC Code	Ddsign LOC	Discription	STATUS
2007-003025	R423	R-CHIP	SA
2007-003025	R424	R-CHIP	SA
2007-008483	R425	R-CHIP	SA
2007-008419	R426	R-CHIP	SA
2007-008419	R427	R-CHIP	SA
2007-008419	R428	R-CHIP	SA
2007-008542	R429	R-CHIP	SA
2007-008419	R430	R-CHIP	SA
2007-008419	R431	R-CHIP	SA
2007-008419	R432	R-CHIP	SA
2007-008419	R433	R-CHIP	SA
2007-008419	R434	R-CHIP	SA
2007-008549	R435	R-CHIP	SA
2007-001119	R436	R-CHIP	SA
2007-008055	R437	R-CHIP	SA
2007-008786	R438	R-CHIP	SA
2007-008786	R439	R-CHIP	SA
2007-007310	R442	R-CHIP	SA
2203-006047	R443	C-CER,CHIP	SA
2203-006047	R444	C-CER,CHIP	SA
2007-008478	R445	R-CHIP	SA
2007-008419	R446	R-CHIP	SA
2007-008055	R447	R-CHIP	SA
2007-008055	R448	R-CHIP	SA
2007-008806	R508	R-CHIP	SA
2007-008806	R509	R-CHIP	SA
2007-008806	R510	R-CHIP	SA
2007-008806	R511	R-CHIP	SA
2007-008806	R512	R-CHIP	SA
2007-008806	R513	R-CHIP	SA
2007-008806	R514	R-CHIP	SA
2007-008483	R515	R-CHIP	SA
2007-008052	R517	R-CHIP	SA
2007-008542	R518	R-CHIP	SA
2007-008483	R519	R-CHIP	SA
2007-008483	R520	R-CHIP	SA

SEC Code	Ddsign LOC	Discription	STATUS
2007-008806	R526	R-CHIP	SA
3705-001358	RFS100	CONNECTOR-COAXIAL	SA
3709-001383	SIM300	CONNECTOR-CARD EDGE	SA
3708-002213	SLC100	CONNECTOR-FPC/FFC/PIC	SA
3708-001890	SLC102	CONNECTOR-FPC/FFC/PIC	SA
3708-002112	SLC103	CONNECTOR-FPC/FFC/PIC	SA
3708-002213	SLC500	CONNECTOR-FPC/FFC/PIC	SA
2809-001295	TCX100	OSCILLATOR-VCTCXO	SA
0504-001012	TR100	TR-DIGITAL	SA
0504-001012	TR101	TR-DIGITAL	SA
0504-001140	TR200	TR-DIGITAL	SA
1203-002713	U100	IC-BATTERY	SA
4709-001368	U102	BLUETOOTH MODULE	SA
1203-002625	U103	IC-POSI.FIXED REG.	SA
1205-002433	U103	IC-TRANSCEIVER	SA
1203-003231	U104	IC-MULTI REG.	SA
1203-003432	U104	IC-POSI.FIXED REG.	SA
1201-002232	U105	IC-AUDIO AMP	SA
1203-003432	U106	IC-POSI.FIXED REG.	SA
1203-003735	U107	IC-POSI.FIXED REG.	SA
1203-003428	U200	IC-DC/DC CONVERTER	SA
1205-002612	U201	IC-CODEC	SA
GH09-00038A	U201	IC MICOM	SA
1001-001261	U202	IC-ANALOG SWITCH	SA
1108-000024	U202	IC-MCP	SA
1009-001020	U203	IC-HALL EFFECT S/W	SA
1203-002861	U204	IC-MULTI REG.	SA
1203-003565	U300	IC-POWER SUPERVISOR	SA
1205-002272	U301	IC-TRANSCEIVER	SA
1209-001219	U302	IC-SENSOR	SA
1203-003434	U304	IC-DC/DC CONVERTER	SA
1205-002681	U401	IC-CODEC	SA
0406-001203	U404	DIODE-TVS	SA
1203-002596	U405	IC-POSI.FIXED REG.	SA
1204-002309	U407	IC-MELODY	SA
1001-001261	U409	IC-ANALOG SWITCH	SA

SEC Code	Ddsign LOC	Discription	STATUS
1203-003789	U500	IC-POWER SUPERVISOR	SA
1205-002568	U501	IC-SWITCH	SA
2011-001363	U621	R-NET	SA
2011-001363	U622	R-NET	SA
1405-001108	VR101	VARISTOR	SA
1405-001121	VR112	VARISTOR	SA
1405-001121	VR113	VARISTOR	SA
1405-001121	VR114	VARISTOR	SA
1405-001121	VR115	VARISTOR	SA
1405-001108	VR119	VARISTOR	SA
1405-001133	VR120	VARISTOR	SA
1405-001133	VR121	VARISTOR	SA
1405-001108	VR122	VARISTOR	SA
1405-001108	VR123	VARISTOR	SA
1405-001108	VR124	VARISTOR	SA
1405-001108	VR125	VARISTOR	SA
1405-001108	VR126	VARISTOR	SA
1405-001108	VR127	VARISTOR	SA
1405-001108	VR128	VARISTOR	SA
1405-001108	VR129	VARISTOR	SA
1405-001108	VR130	VARISTOR	SA
1405-001108	VR131	VARISTOR	SA
1405-001108	VR132	VARISTOR	SA
1405-001108	VR133	VARISTOR	SA
1405-001108	VR134	VARISTOR	SA
1405-001108	VR135	VARISTOR	SA
1405-001108	VR136	VARISTOR	SA
1405-001108	VR137	VARISTOR	SA
1405-001108	VR138	VARISTOR	SA
1405-001108	VR139	VARISTOR	SA
1405-001108	VR140	VARISTOR	SA
1405-001082	VR201	VARISTOR	SA
1405-001108	VR201	VARISTOR	SA
1405-001082	VR202	VARISTOR	SA
1405-001133	VR202	VARISTOR	SA
1405-001133	VR203	VARISTOR	SA

SEC Code	Ddsign LOC	Discription	STATUS
1405-001108	VR204	VARISTOR	SA
1405-001108	VR301	VARISTOR	SA
1405-001108	VR302	VARISTOR	SA
1405-001108	VR303	VARISTOR	SA
1405-001108	VR304	VARISTOR	SA
1405-001108	VR305	VARISTOR	SA
1405-001108	VR306	VARISTOR	SA
1405-001108	VR307	VARISTOR	SA
1405-001108	VR308	VARISTOR	SA
1405-001108	VR309	VARISTOR	SA
1405-001108	VR310	VARISTOR	SA
1405-001108	VR311	VARISTOR	SA
1405-001108	VR312	VARISTOR	SA
1405-001082	VR400	VARISTOR	SA
1405-001082	VR401	VARISTOR	SA
1405-001082	VR404	VARISTOR	SA
1405-001082	VR405	VARISTOR	SA
1405-001082	VR408	VARISTOR	SA
1405-001082	VR409	VARISTOR	SA
1405-001082	VR500	VARISTOR	SA
1405-001108	VR501	VARISTOR	SA
1405-001082	VR502	VARISTOR	SA
1405-001108	ZD100	VARISTOR	SA
1405-001108	ZD101	VARISTOR	SA
0406-001203	ZD200	DIODE-TVS	SA
0406-001203	ZD201	DIODE-TVS	SA
0406-001208	ZD201	DIODE-TVS	SA
0406-001208	ZD202	DIODE-TVS	SA
0406-001208	ZD203	DIODE-TVS	SA
0406-001203	ZD300	DIODE-TVS	SA
0406-001203	ZD302	DIODE-TVS	SA
0406-001203	ZD303	DIODE-TVS	SA
0406-001203	ZD304	DIODE-TVS	SA
0406-001203	ZD305	DIODE-TVS	SA
0406-001203	ZD306	DIODE-TVS	SA
0406-001203	ZD307	DIODE-TVS	SA

SEC Code	Ddsign LOC	Discription	STATUS
0406-001203	ZD308	DIODE-TVS	SA
0406-001150	ZD309	DIODE-TVS	SA
0406-001203	ZD400	DIODE-TVS	SA
0403-001547	ZD401	DIODE-ZENER	SA
0406-001150	ZD404	DIODE-TVS	SA
0406-001150	ZD405	DIODE-TVS	SA
0406-001150	ZD406	DIODE-TVS	SA
0406-001203	ZD407	DIODE-TVS	SA
0406-001203	ZD408	DIODE-TVS	SA
0403-001547	ZD410	DIODE-ZENER	SA
0406-001104	ZD411	DIODE-TVS	SA
0406-001104	ZD412	DIODE-TVS	SA
0406-001203	ZD501	DIODE-TVS	SA
0406-001203	ZD502	DIODE-TVS	SA
0406-001203	ZD503	DIODE-TVS	SA
0407-000115	ZD505	DIODE-ARRAY	SA
0406-001203	ZD506	DIODE-TVS	SA
0406-001203	ZD507	DIODE-TVS	SA
0406-001203	ZD508	DIODE-TVS	SA

7. Block Diagrams

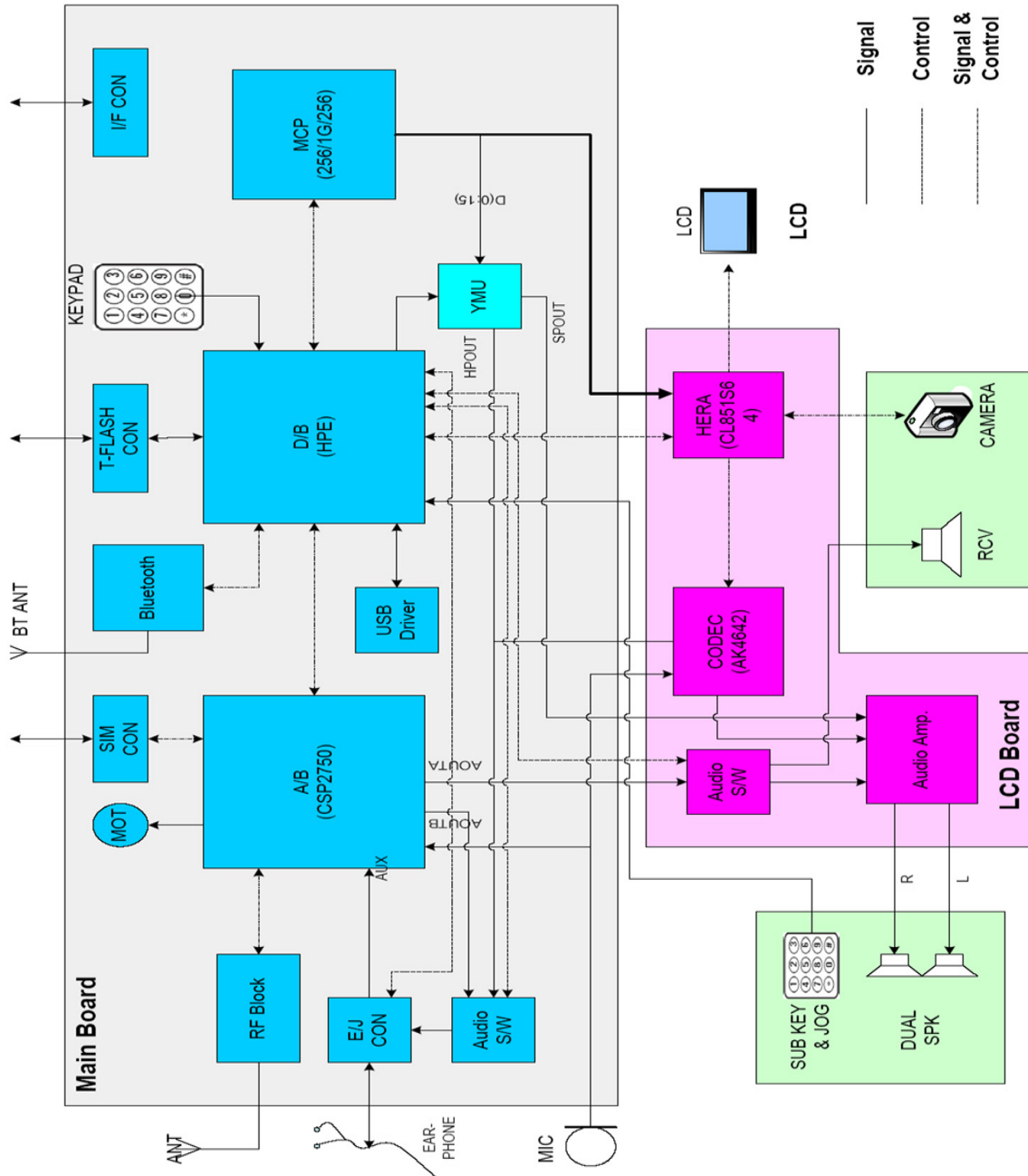

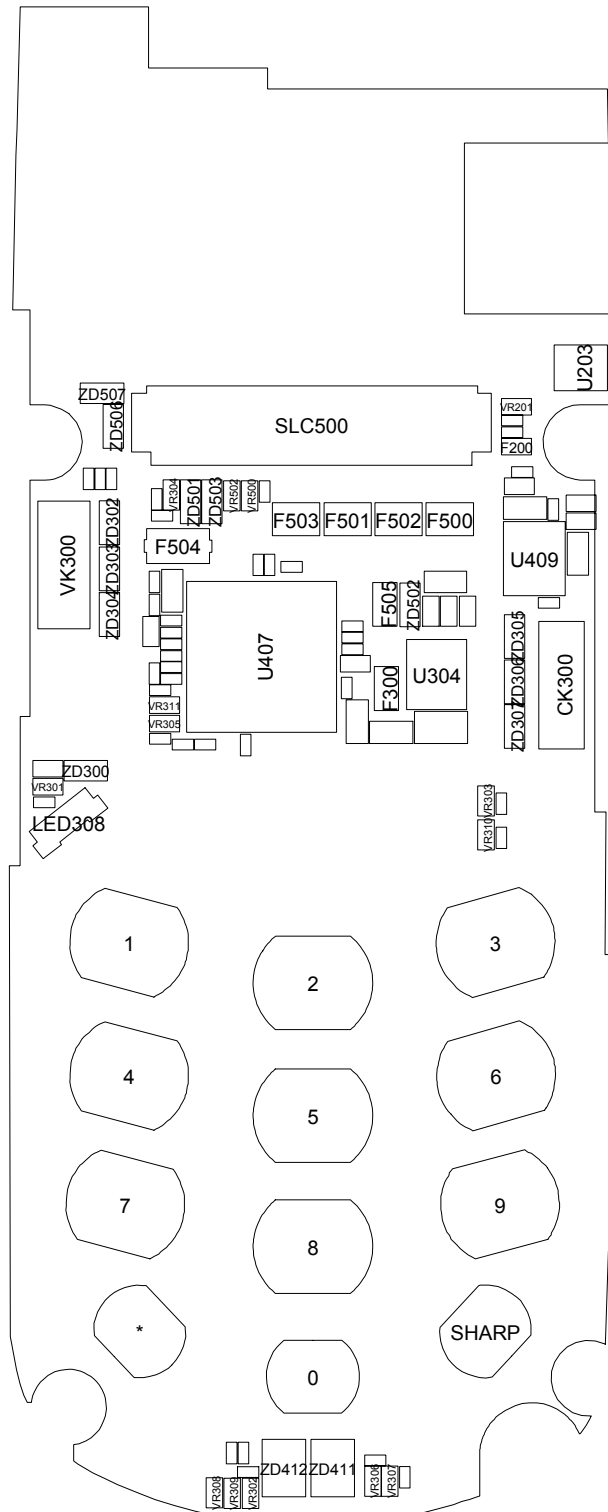

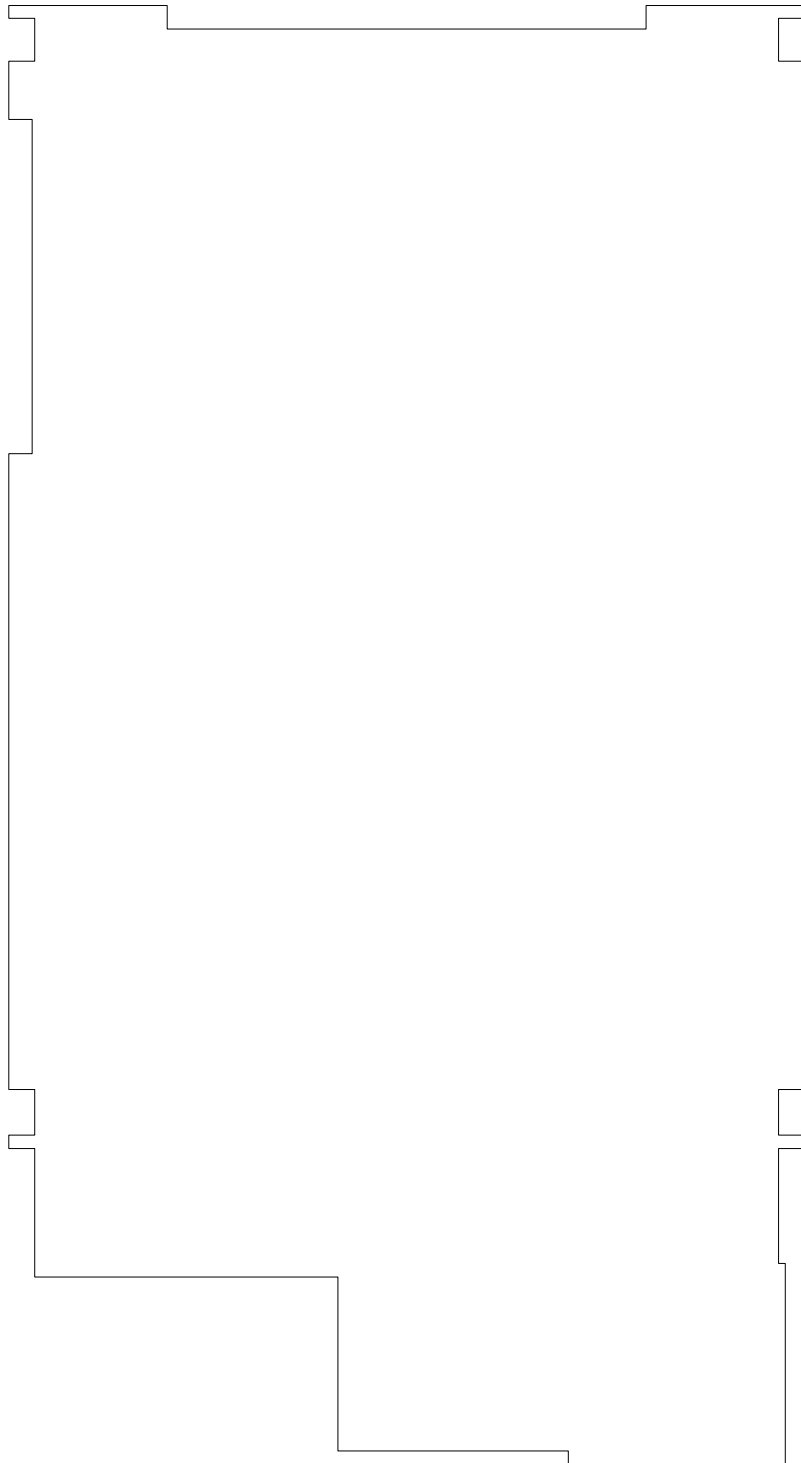

9. Flow Chart of Troubleshooting

9-1 BASEBAND

9-1-1. Power ON

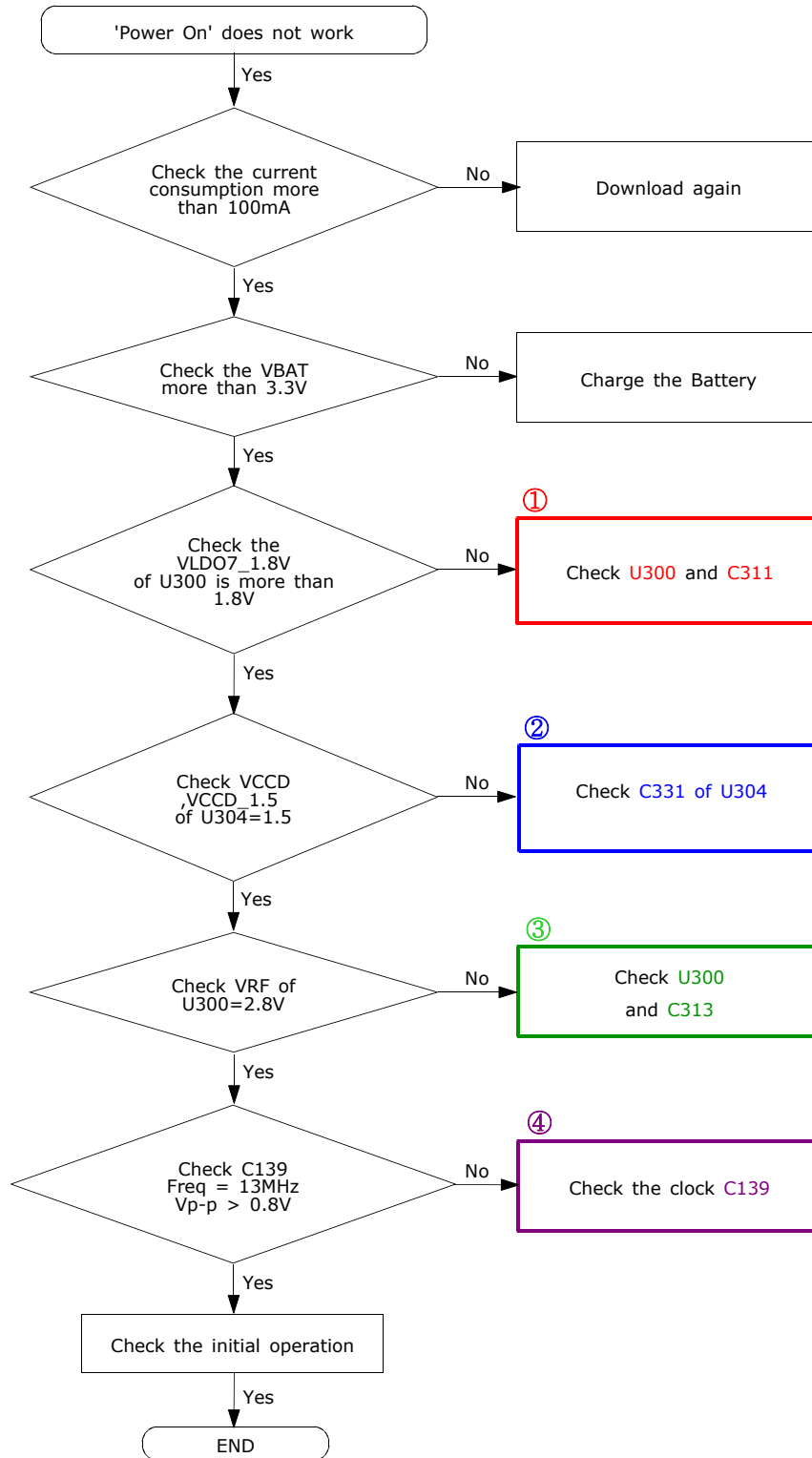

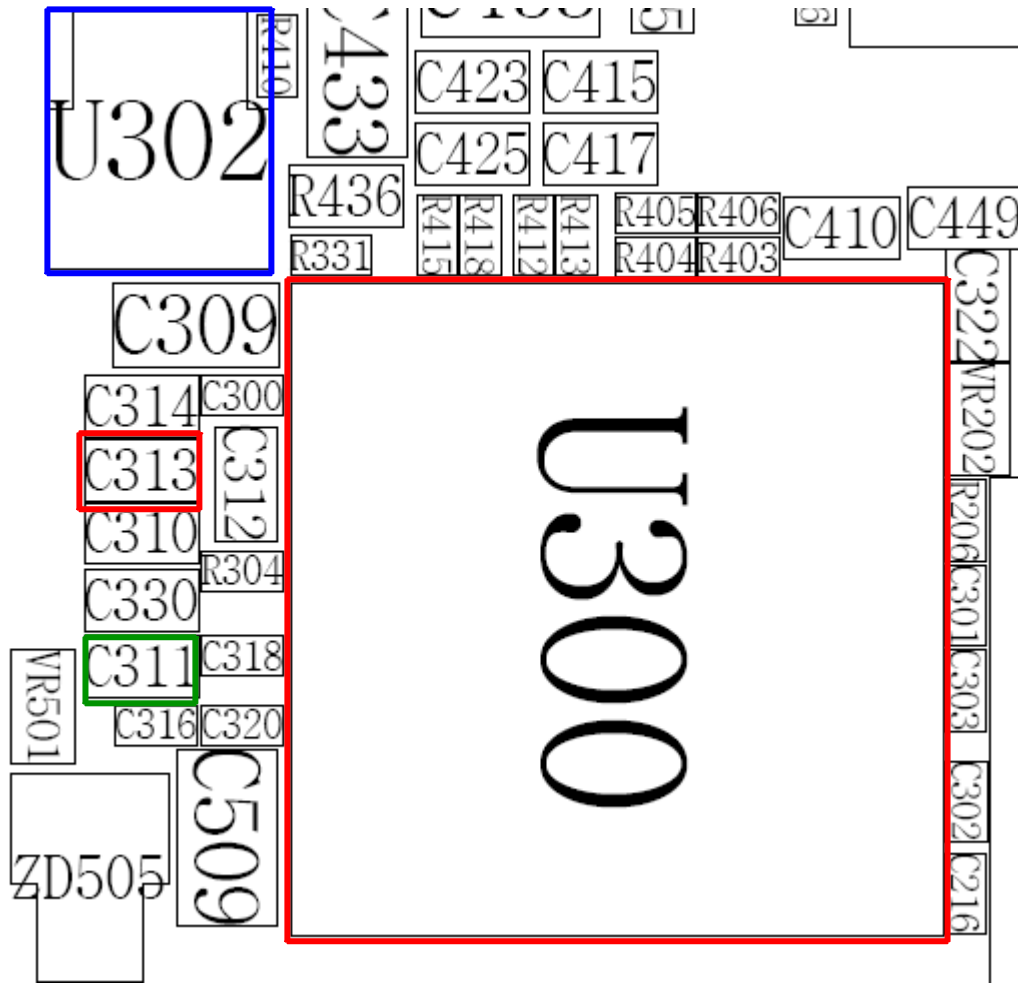

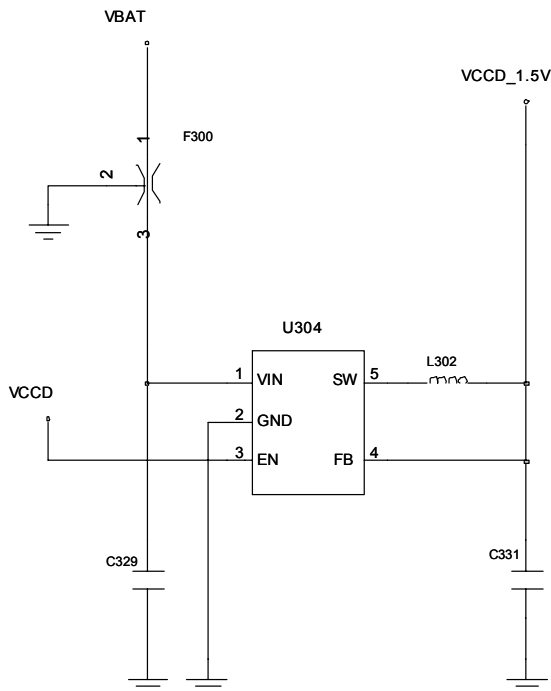
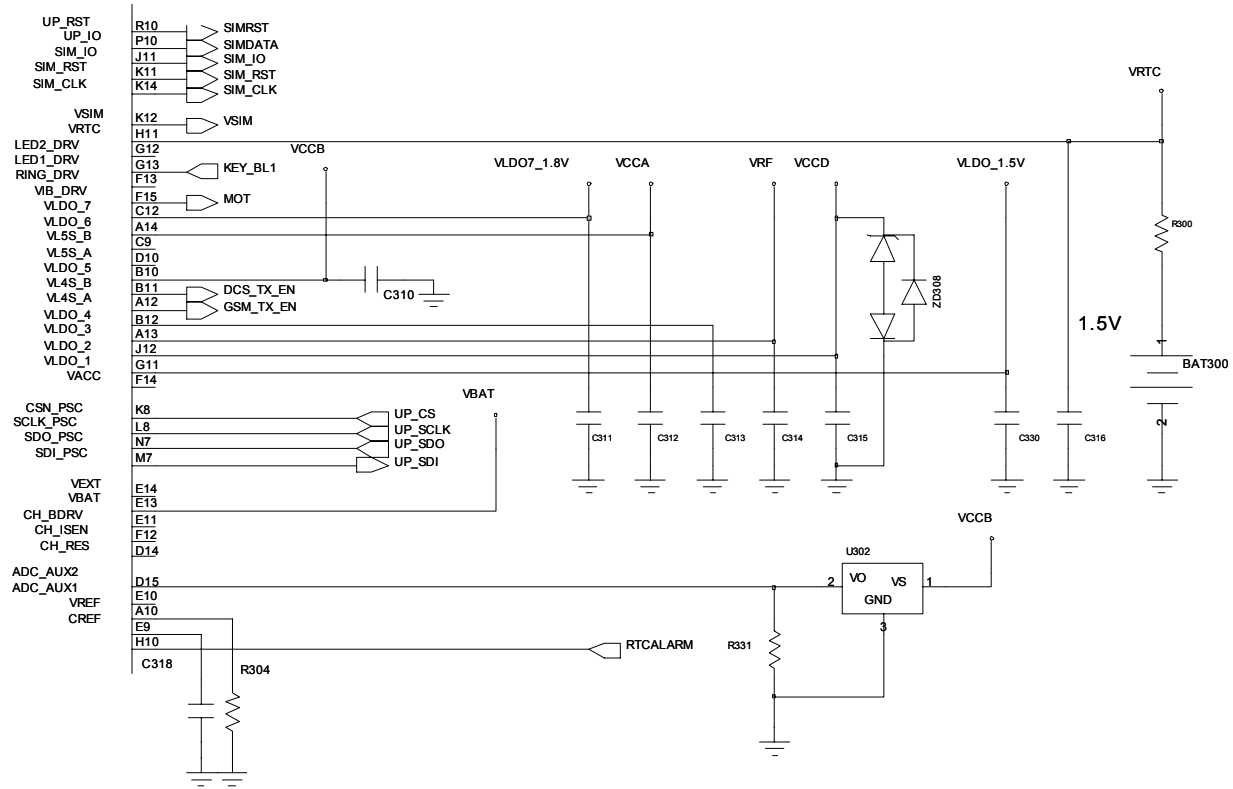

9-2-2. Initial

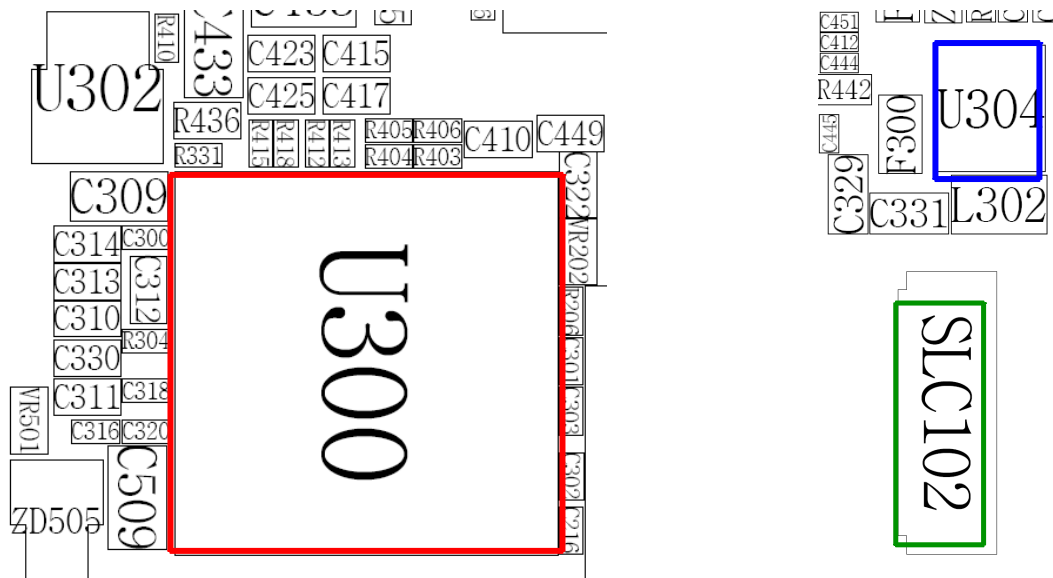
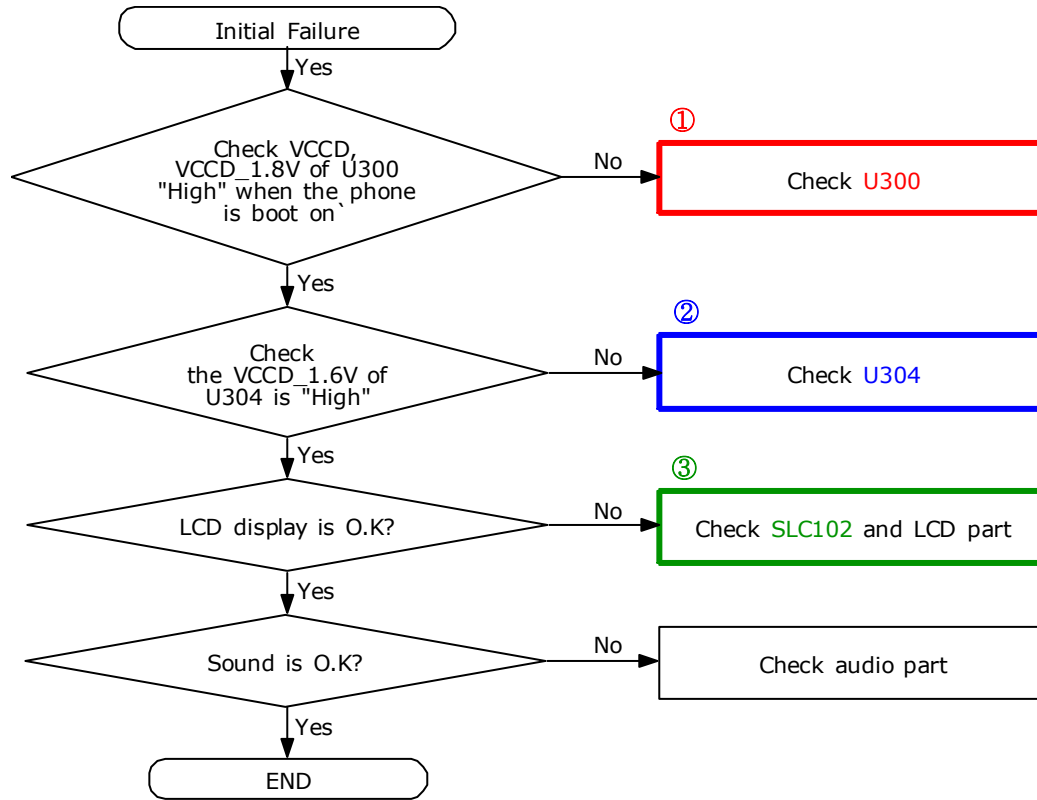

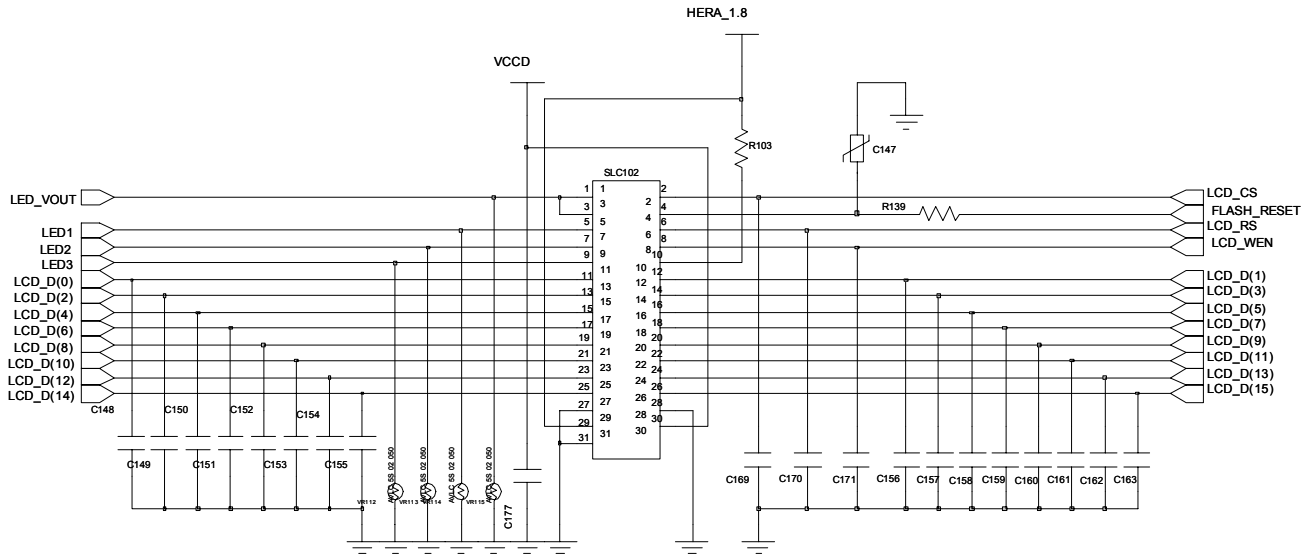

9-1-3. Sim Part

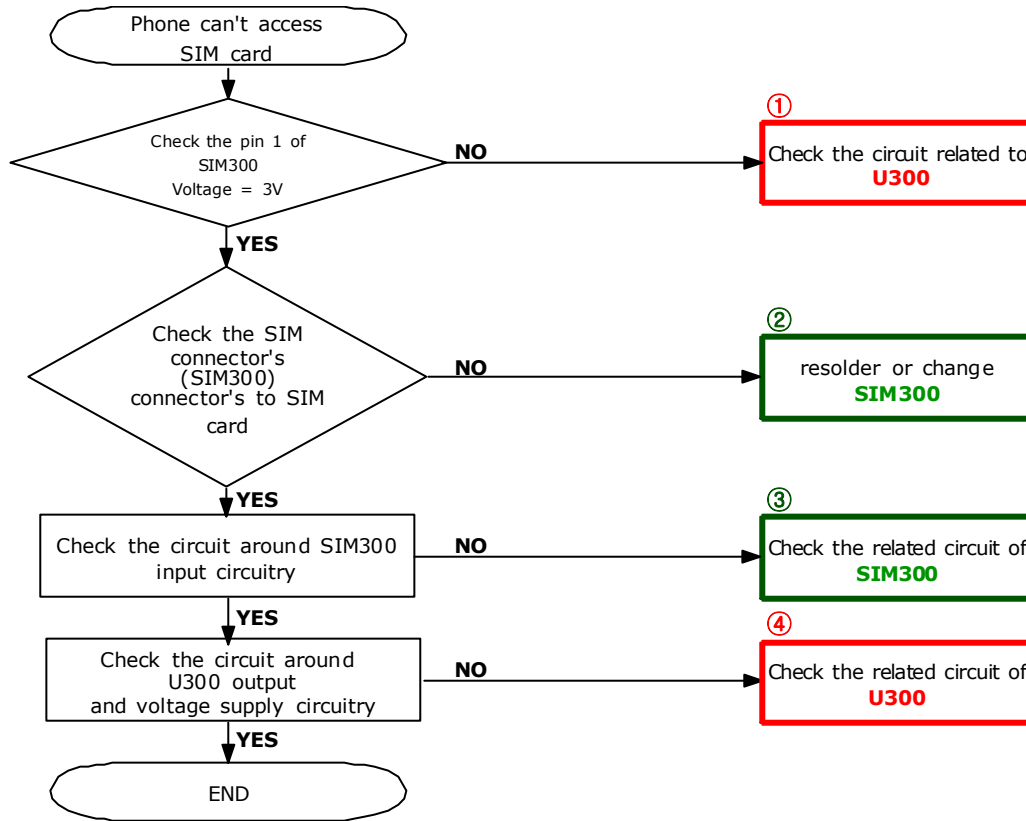

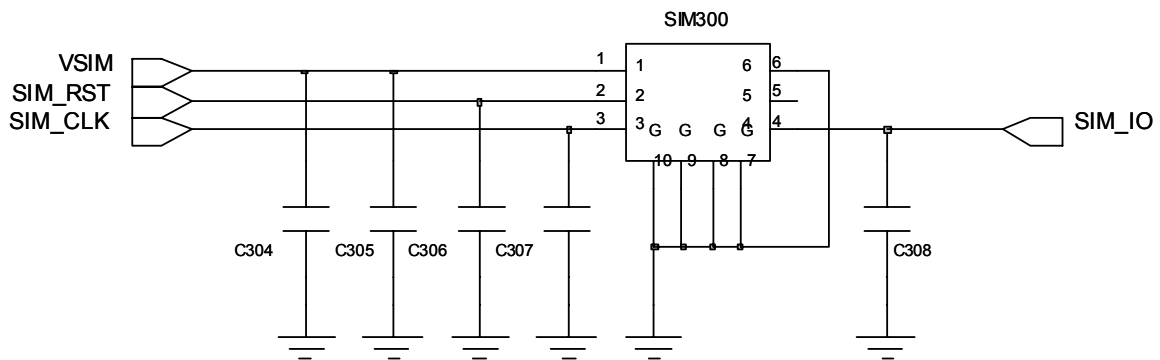
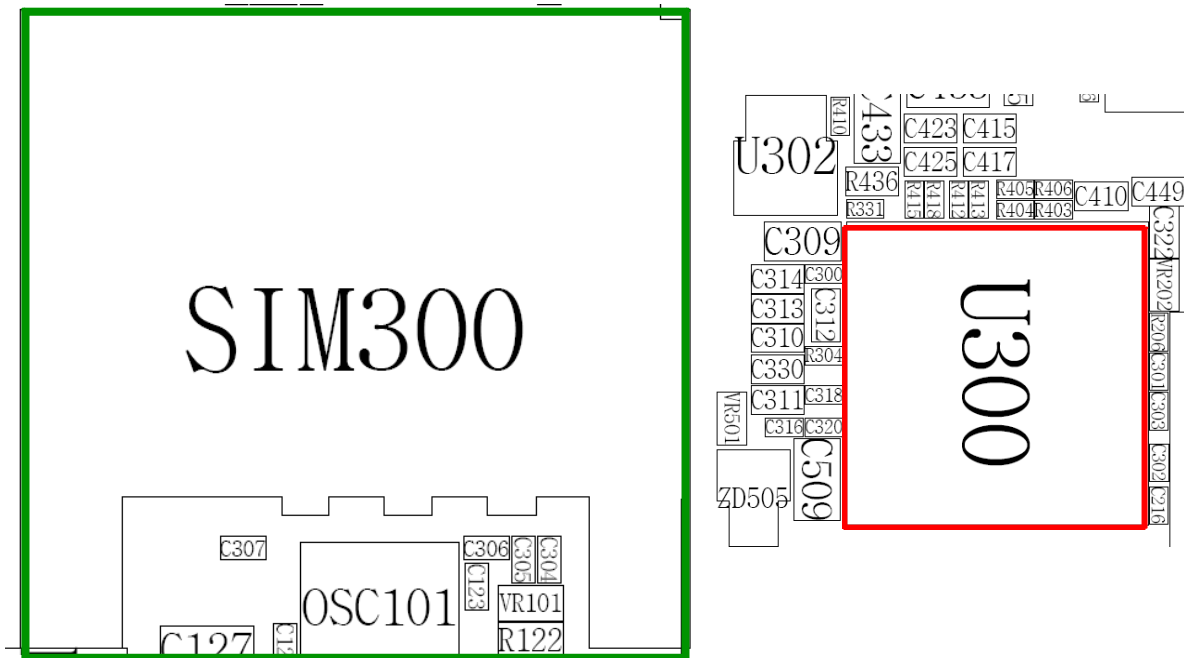

9-1-4. Charging Part

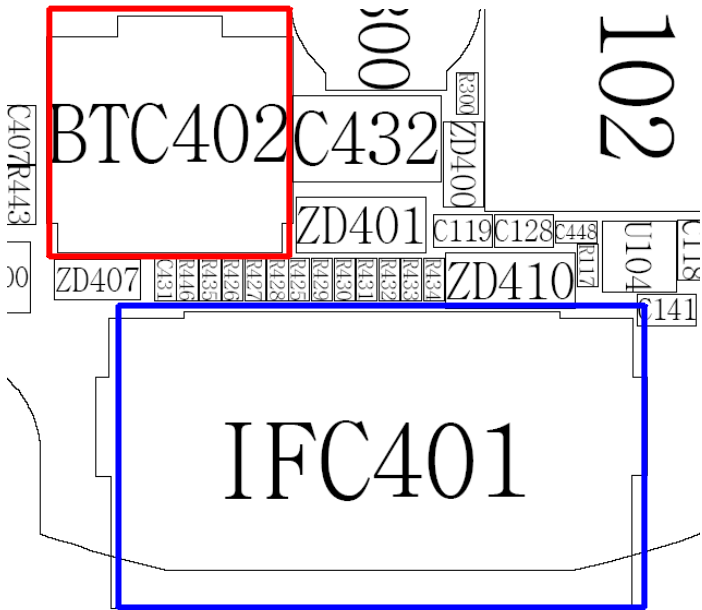
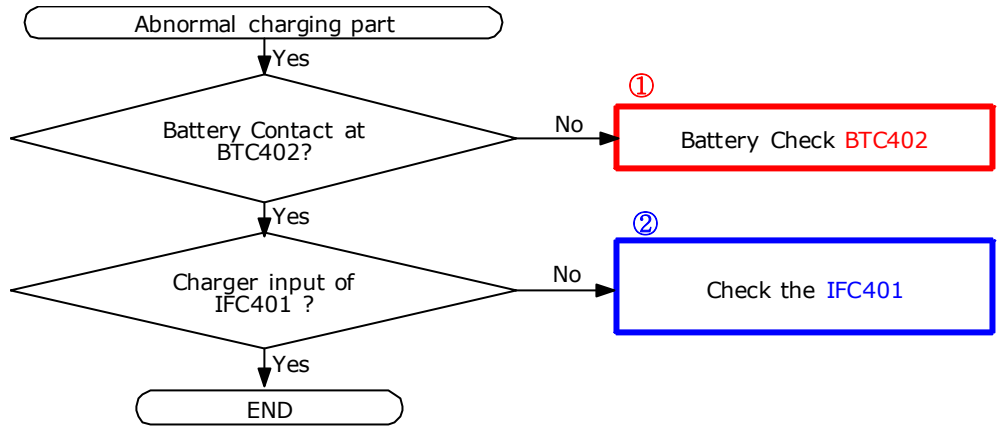

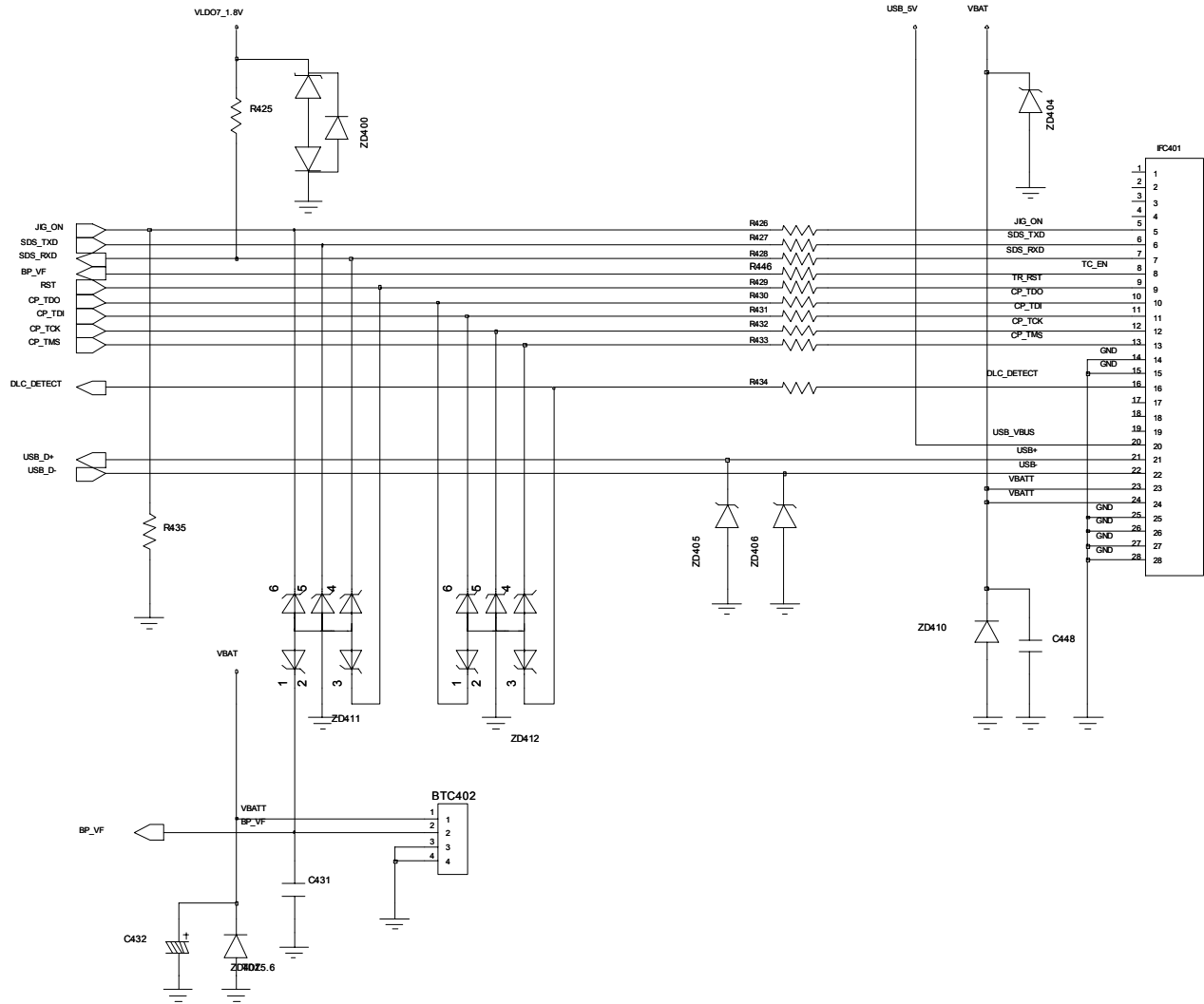

9-1-5. Microphone Part

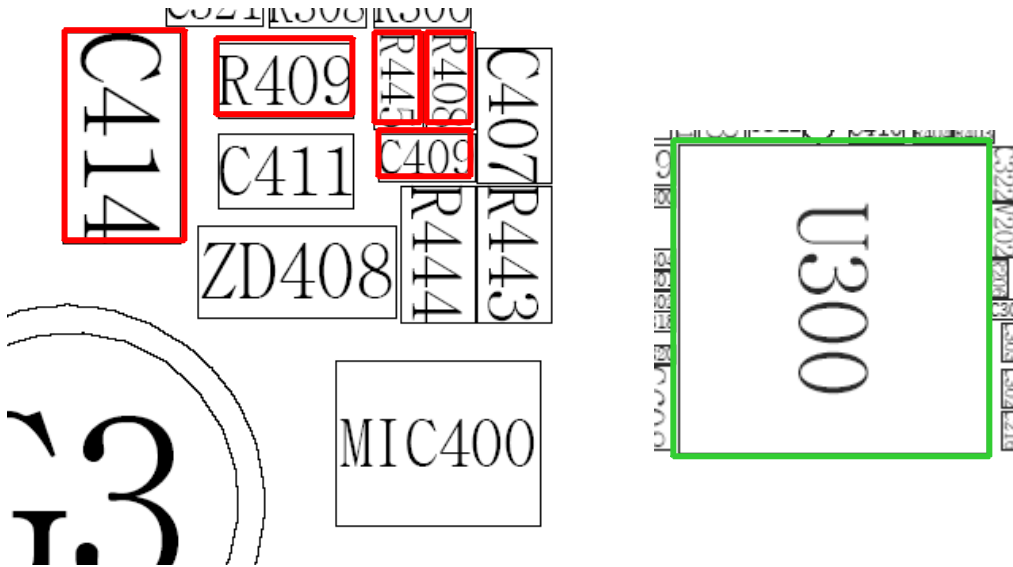
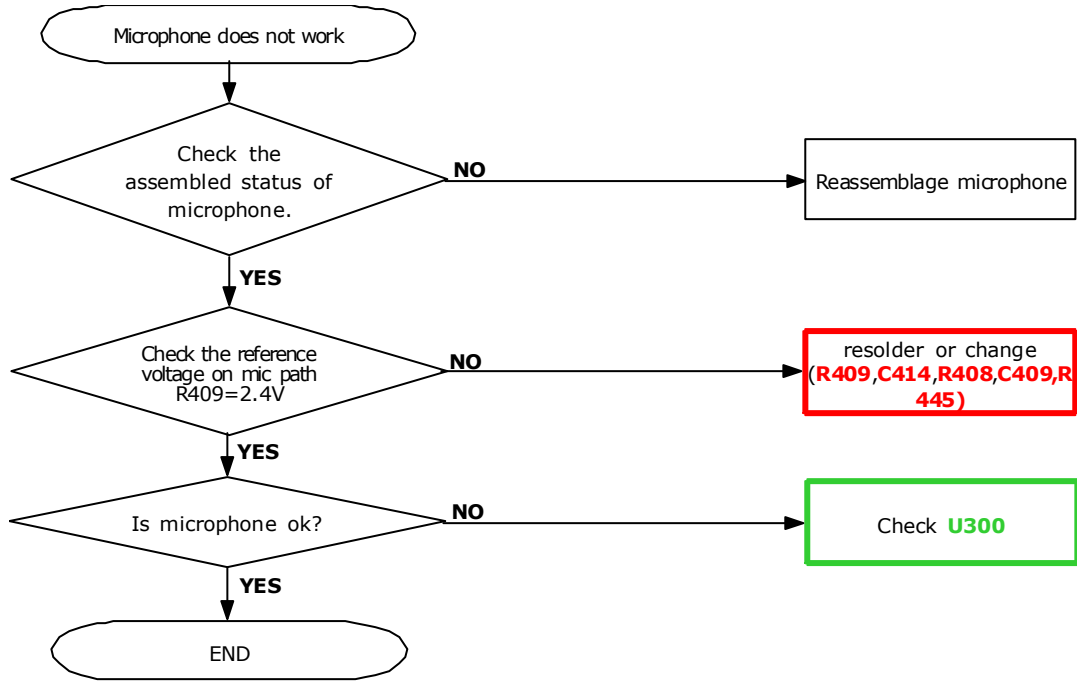

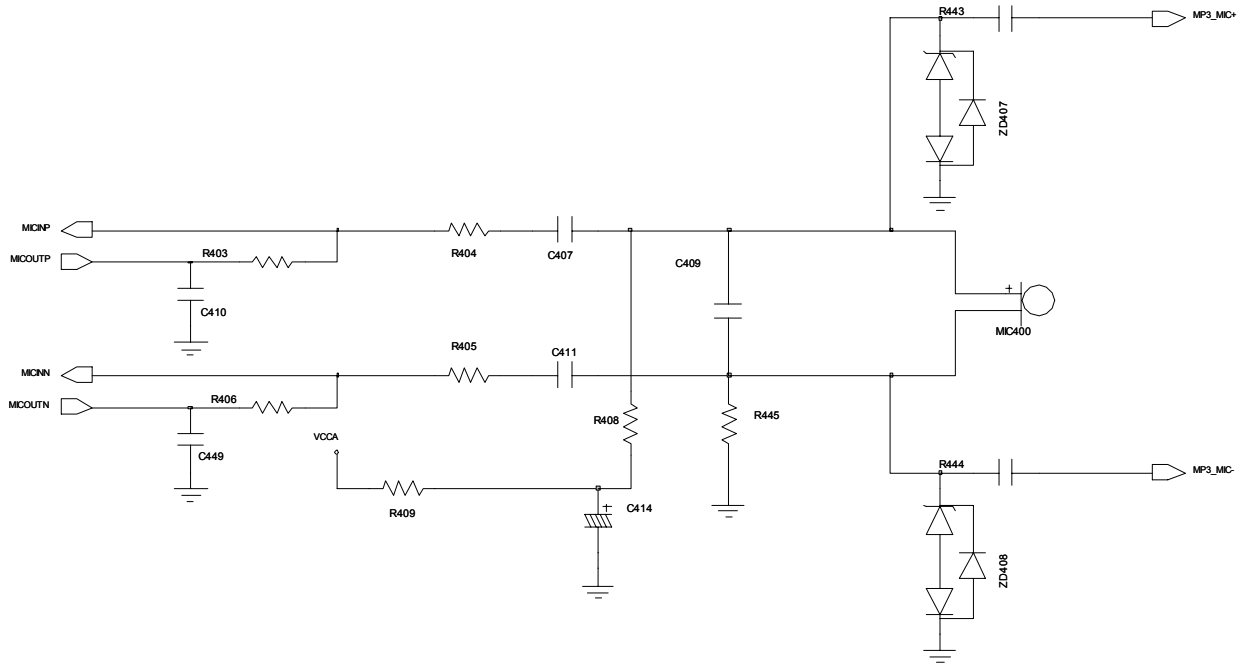

U300

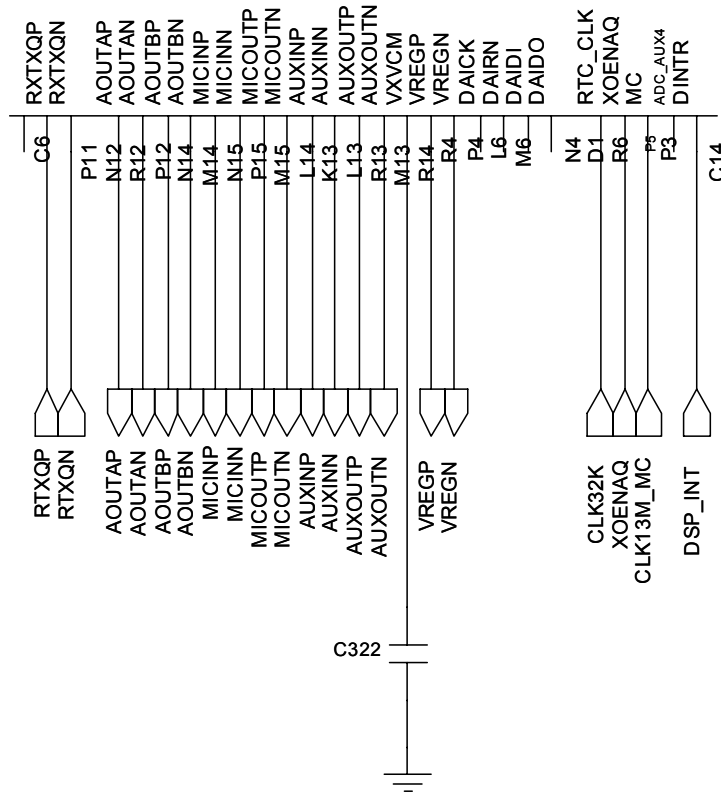

9-1-6. Speaker Part

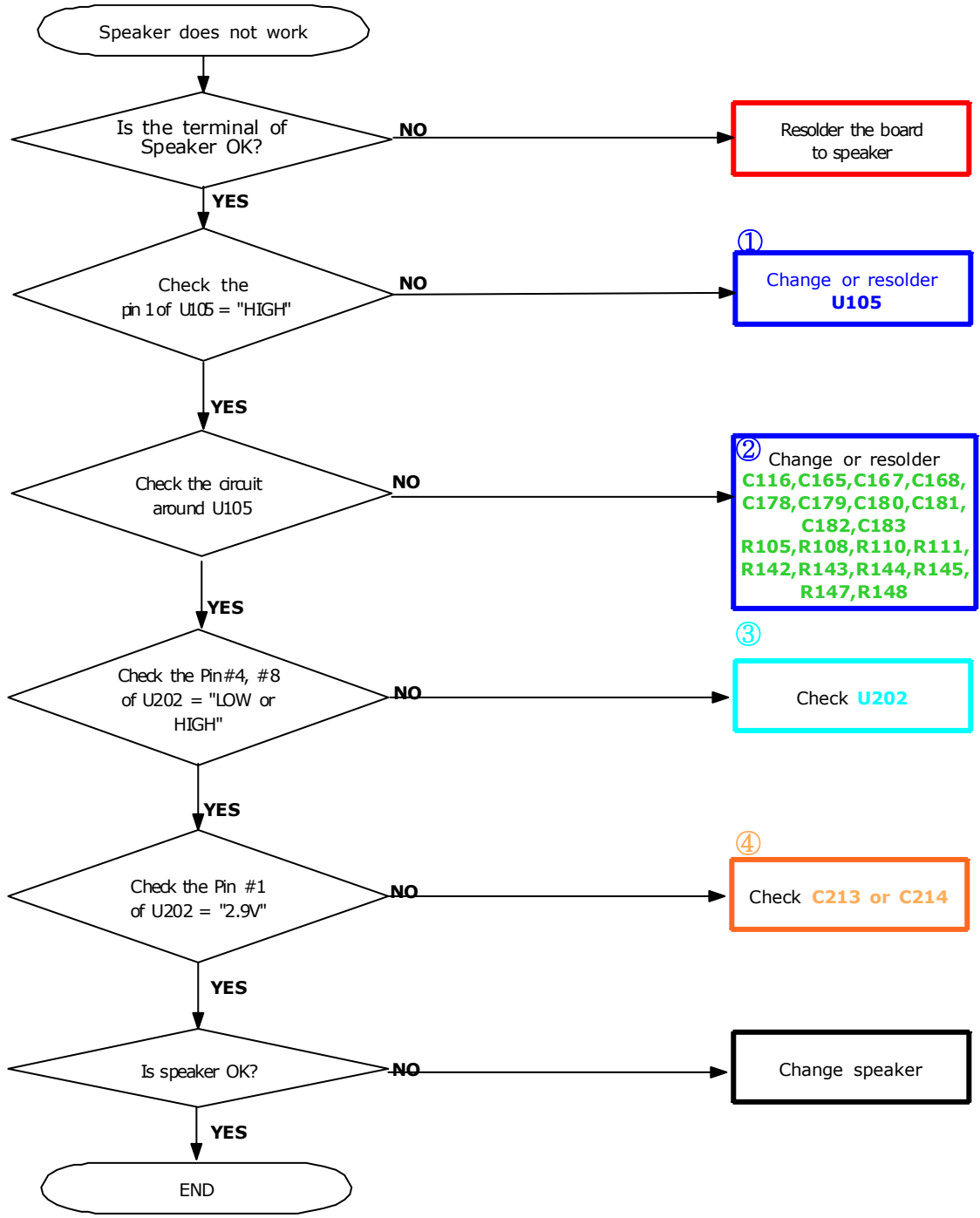

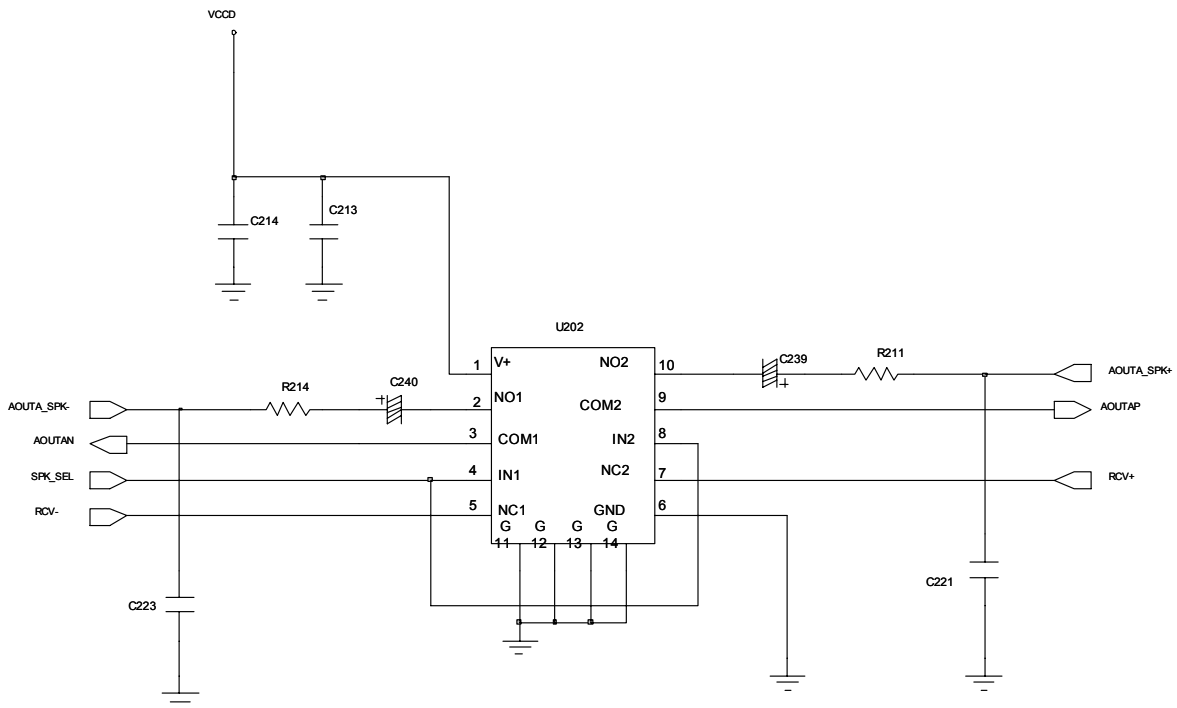
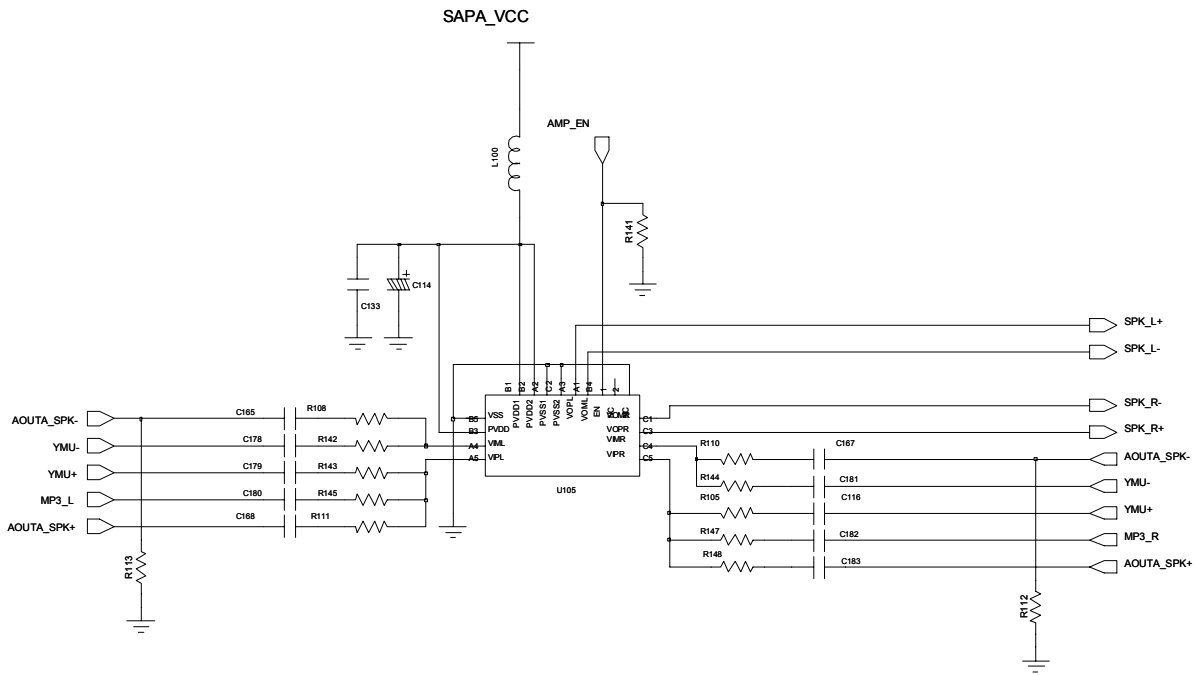

9-1-7. LCD

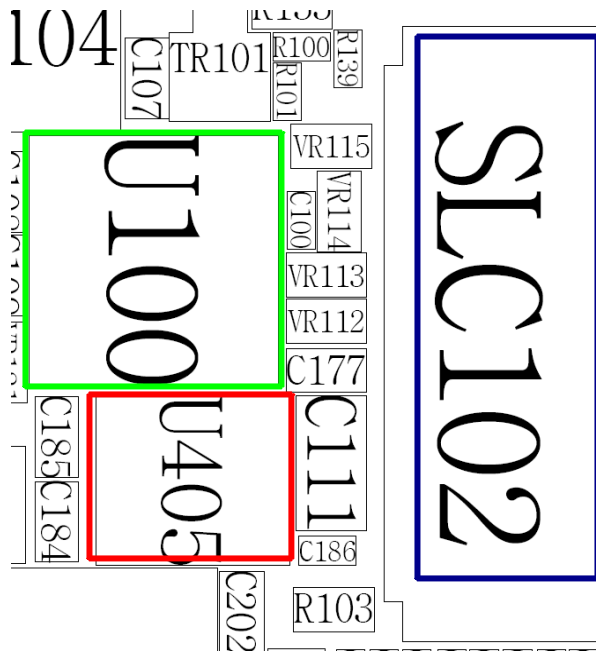
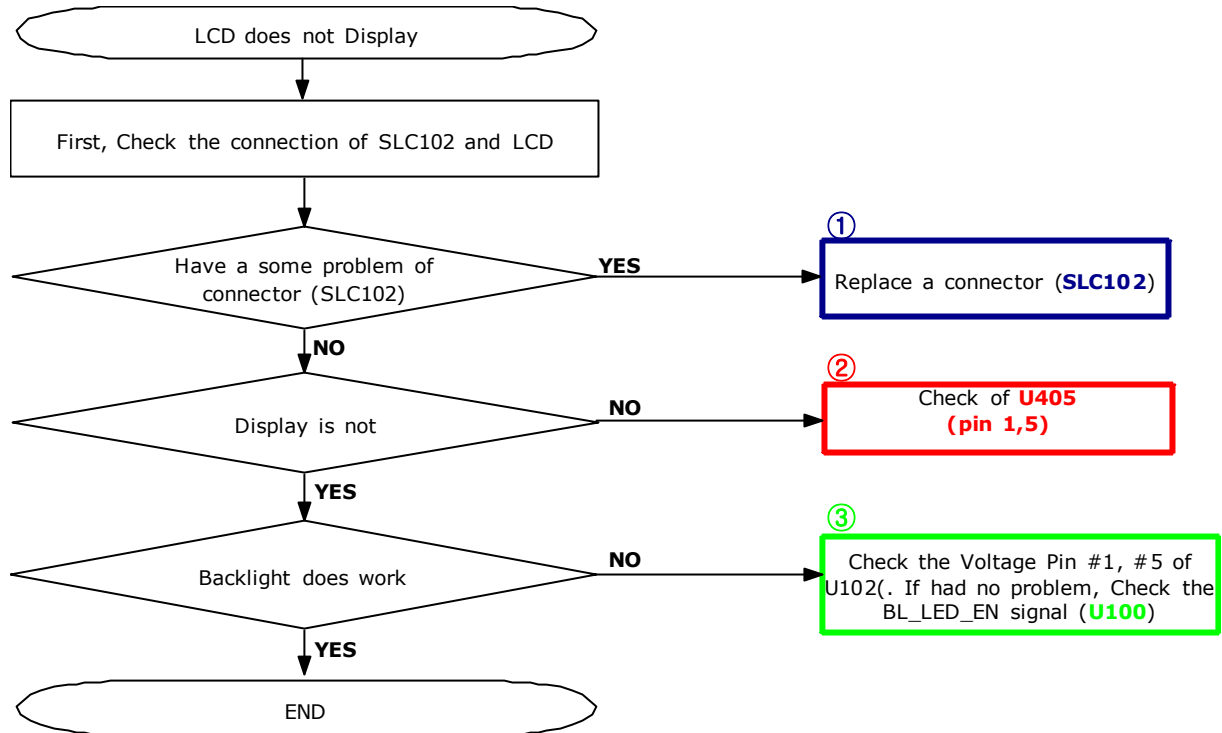

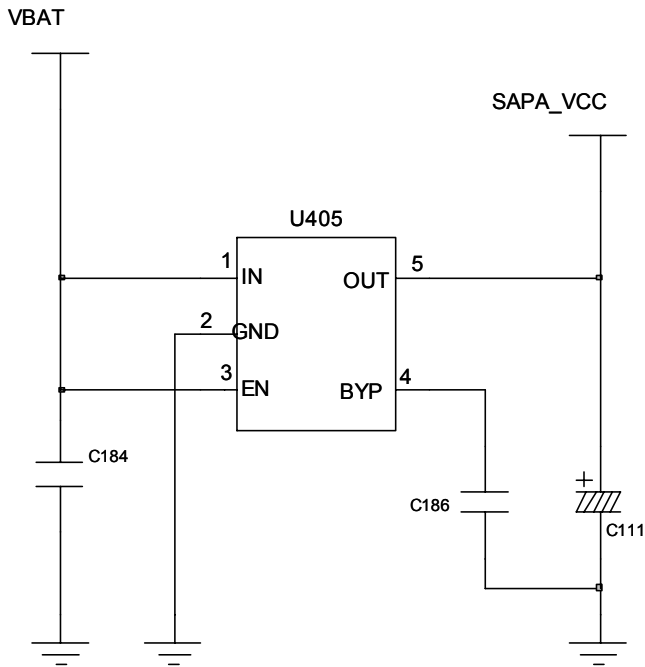
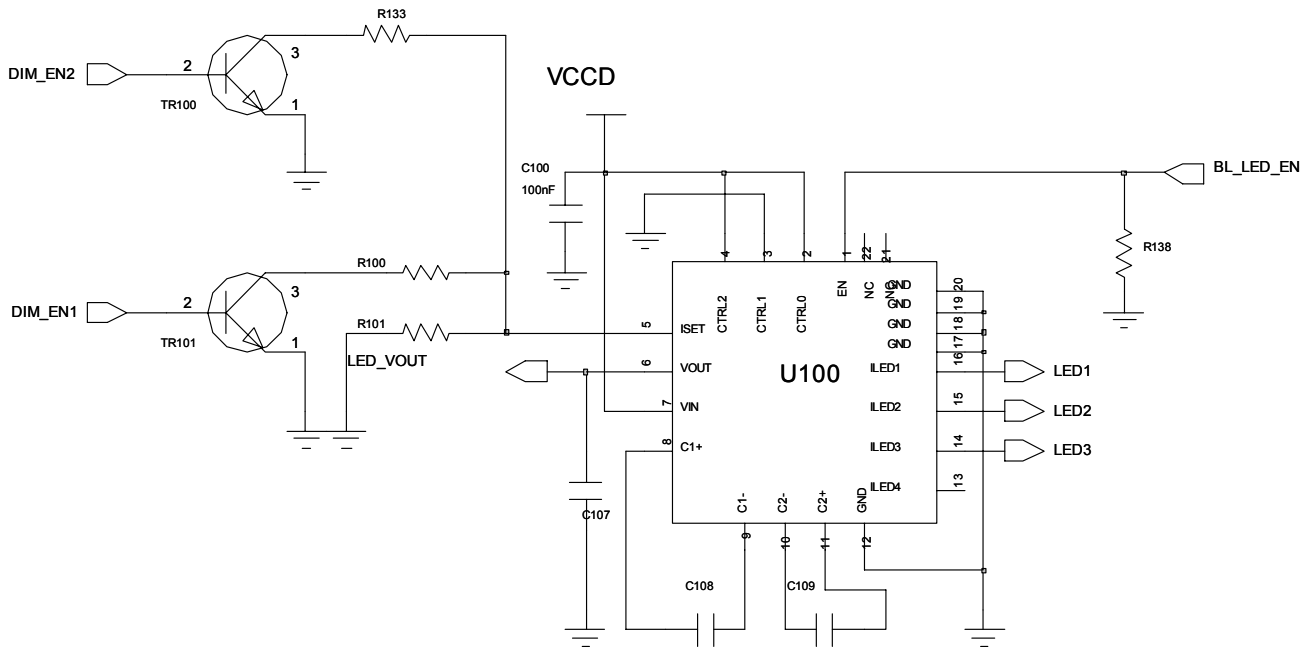

9-1-8. Camera

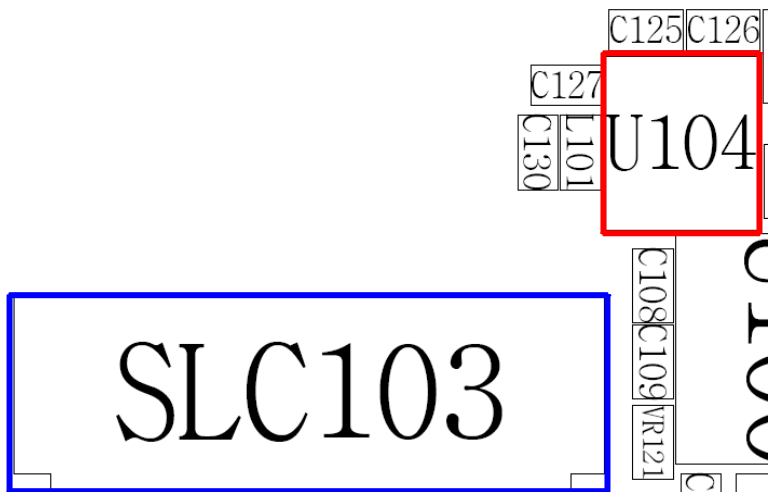
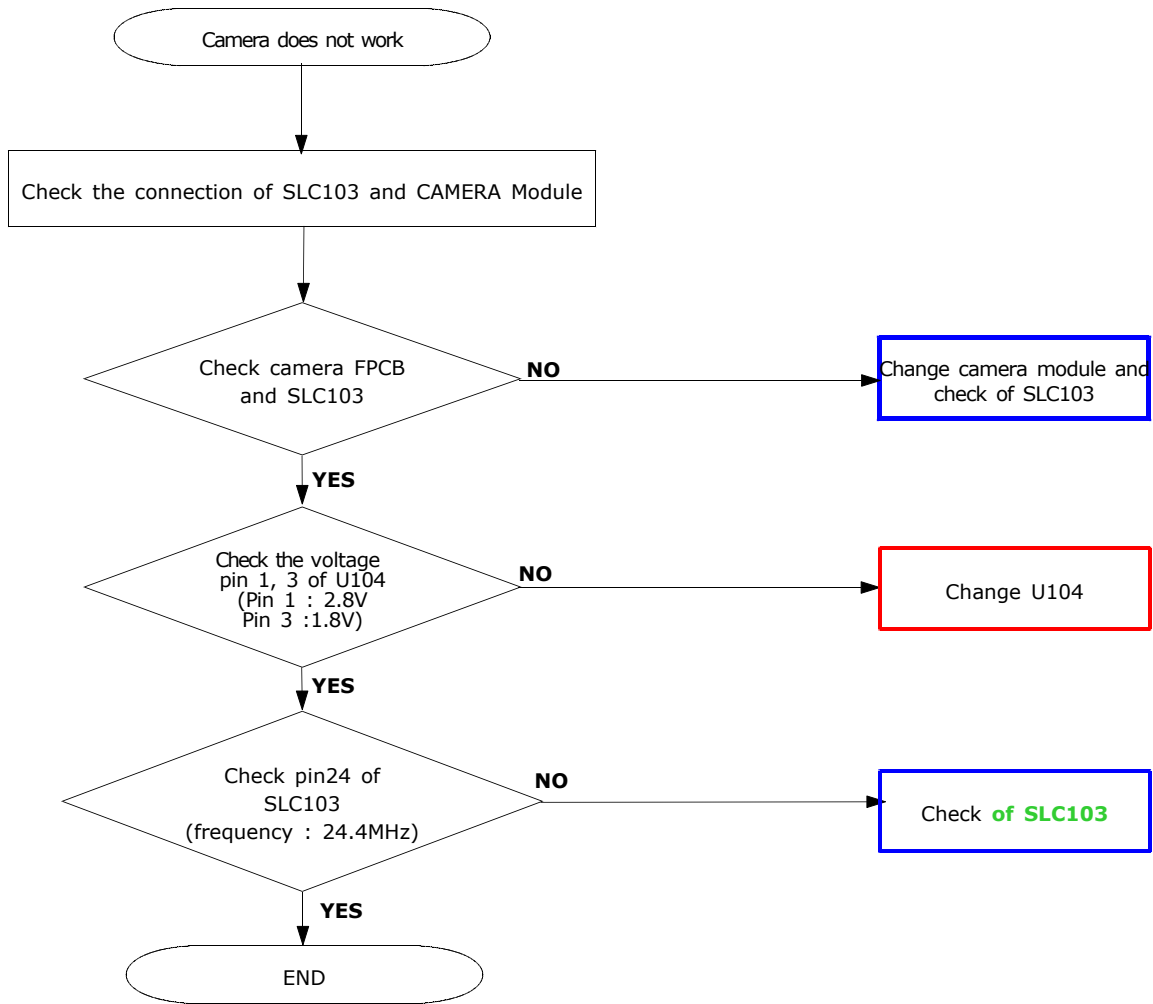

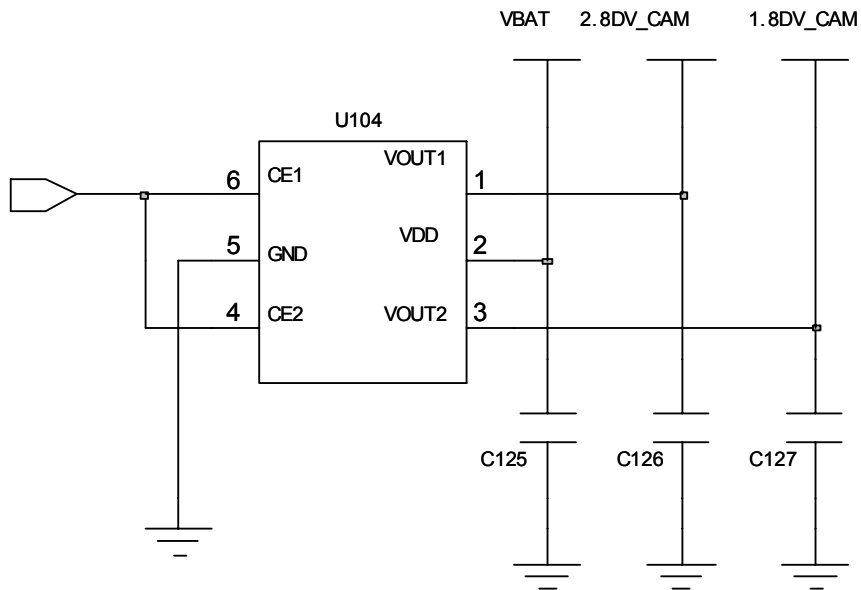
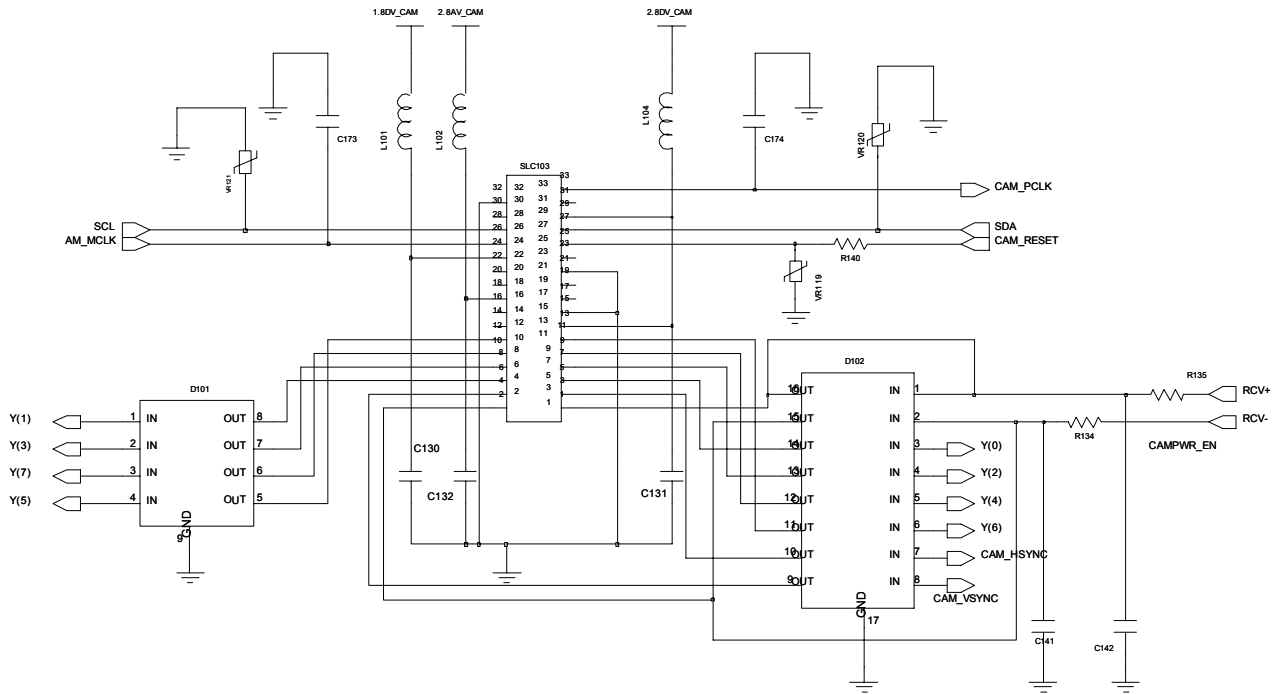

9-2. RF

9-2-1. GSM Receiver

CONTINUOUS RX ON
RF INPUT : 62CH
Cell power : -50dBm

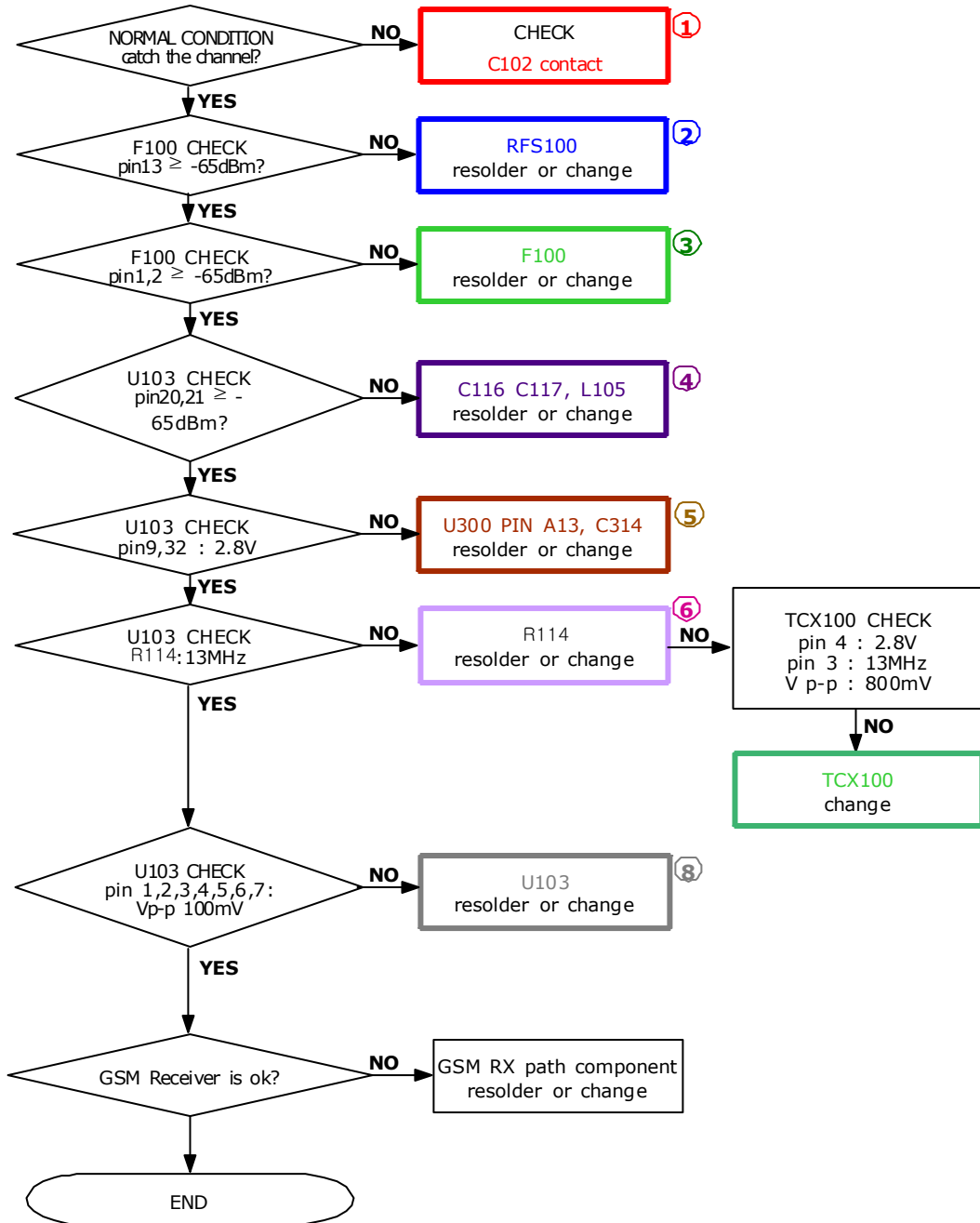

9-2-2. DCS Receiver

CONTINUOUS RX ON
RF INPUT : 698CH
Cell power : -50dBm

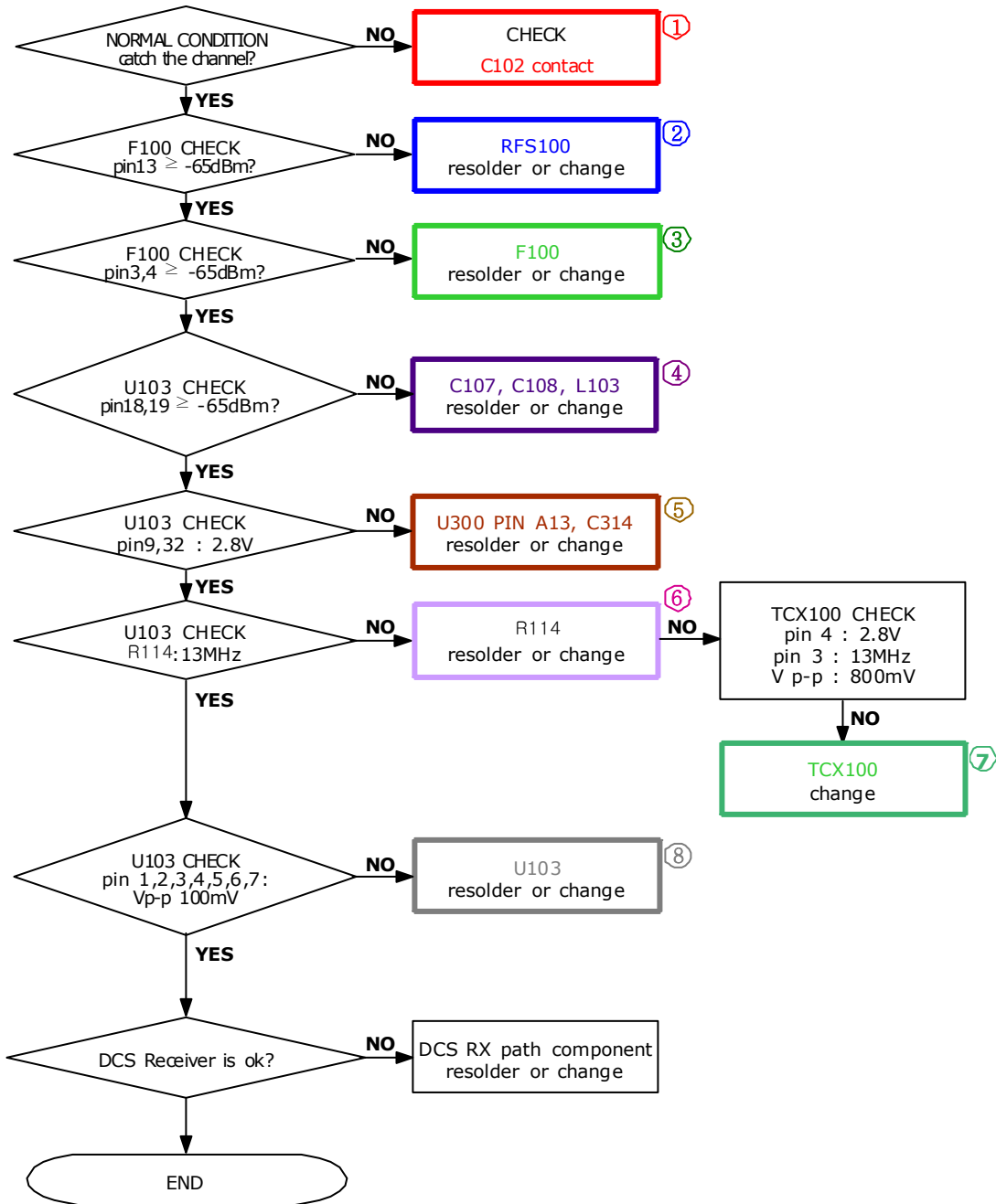

9-2-3. PCS Receiver

CONTINUOUS RX ON
RF INPUT : 698CH
Cell power : -50dBm

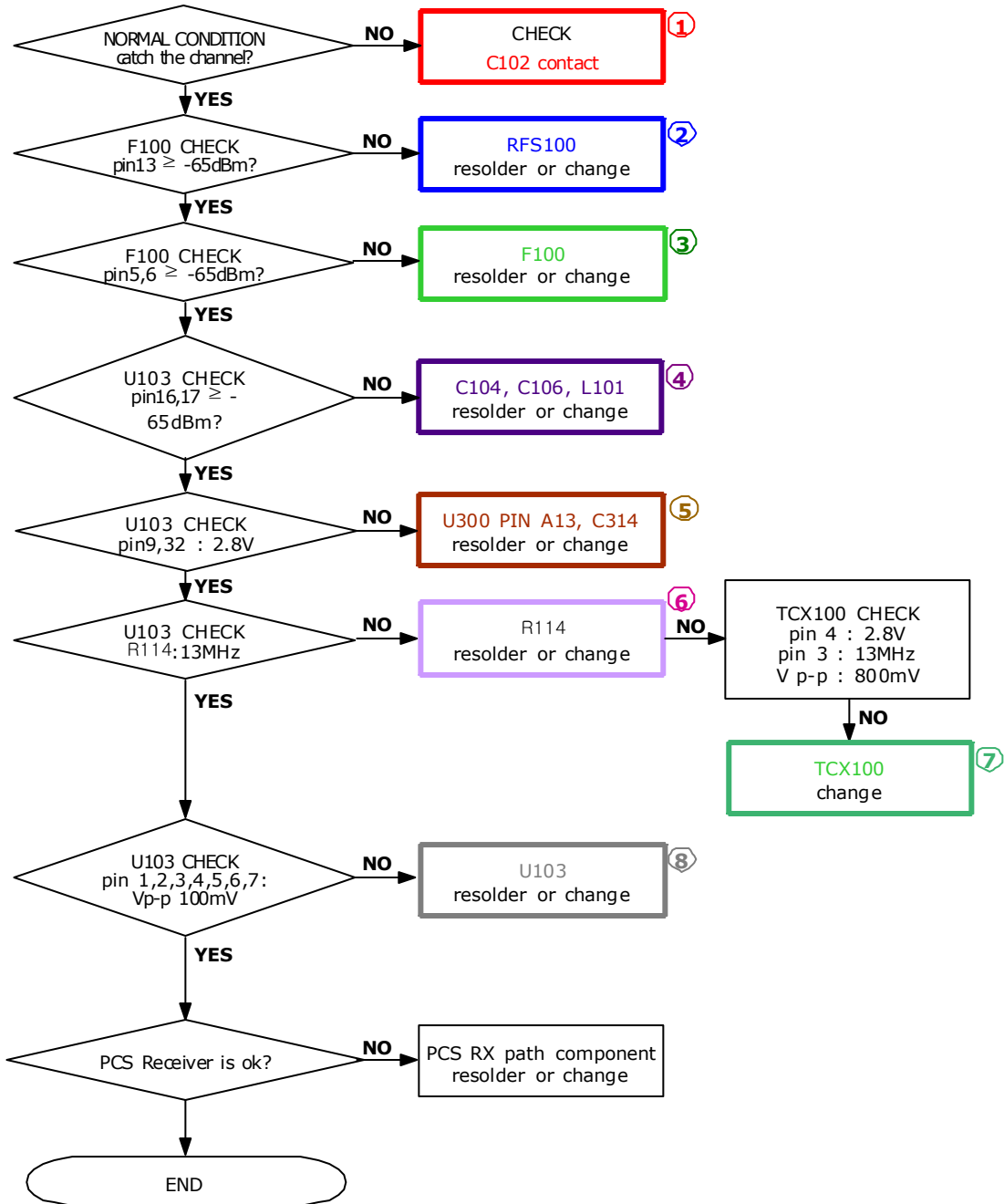



9-2-4. GSM Transmitter

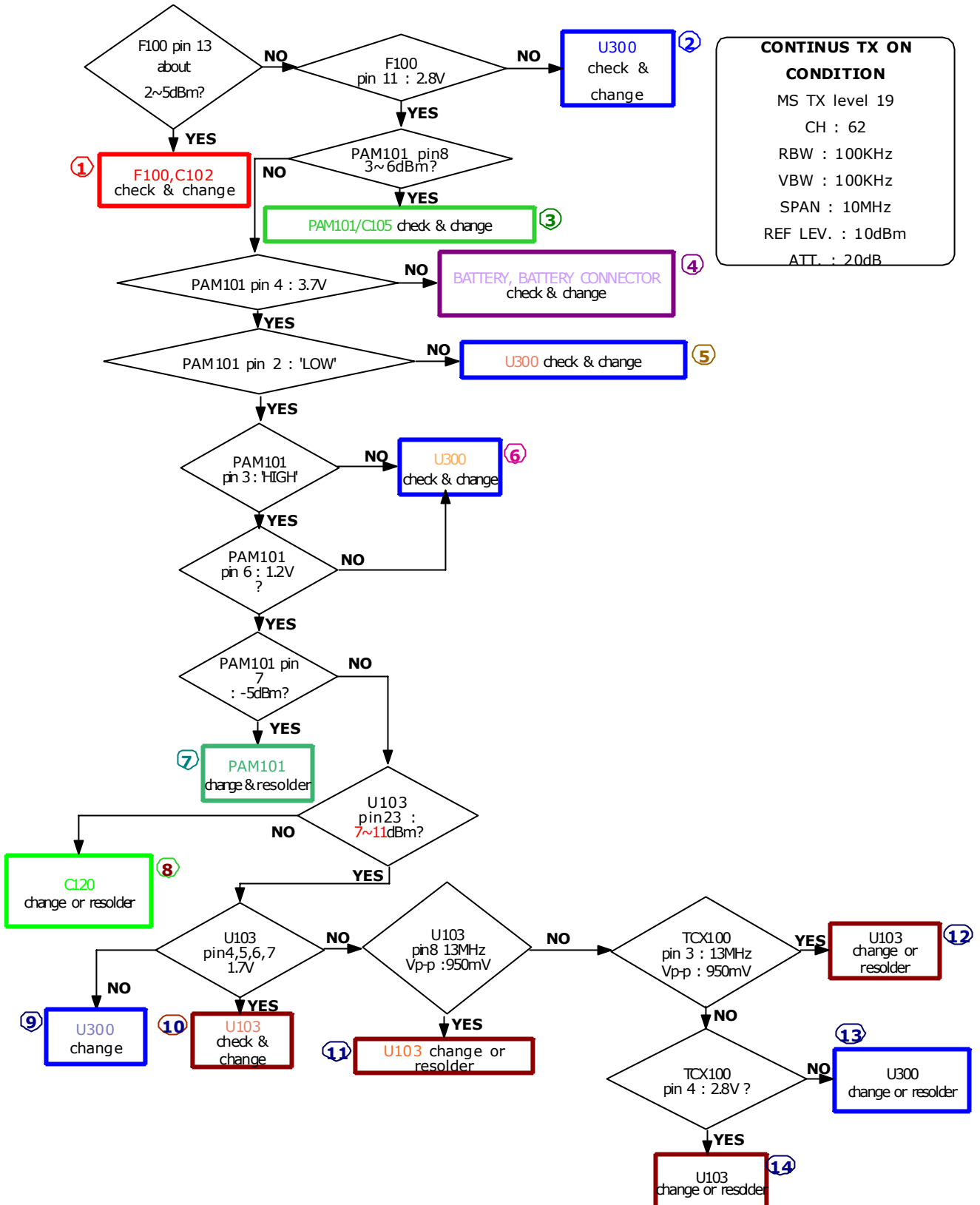

**CONTINUS TX ON
CONDITION**
 MS TX level 19
 CH : 62
 RBW : 100KHz
 VBW : 100KHz
 SPAN : 10MHz
 REF LEV. : 10dBm
 ATT. : 20dB

9-2-5. DCS Transmitter

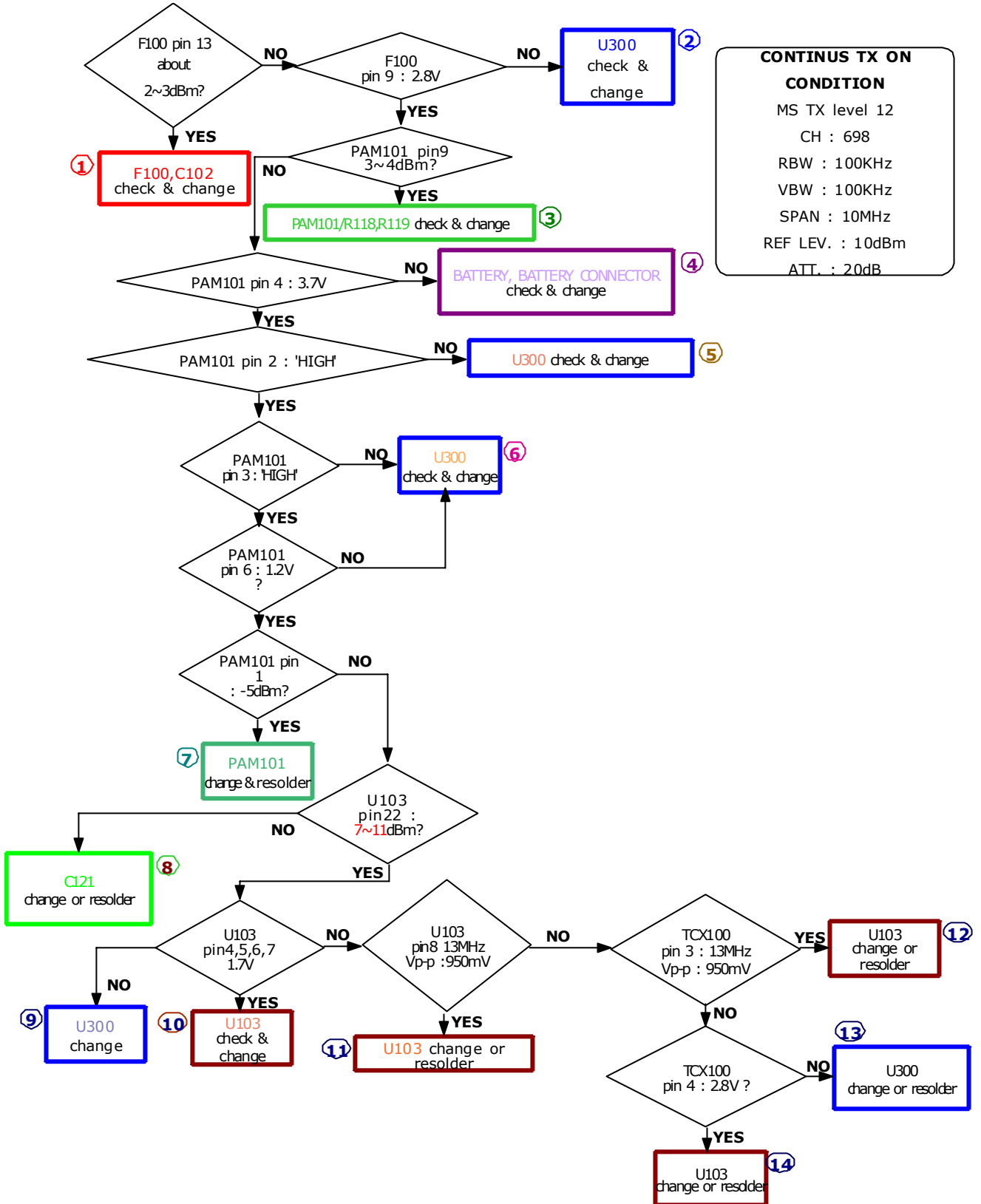

**CONTINUS TX ON
CONDITION**
 MS TX level 12
 CH : 698
 RBW : 100KHz
 VBW : 100KHz
 SPAN : 10MHz
 REF LEV. : 10dBm
 ATT. : 20dB

9-2-6. PCS Transmitter

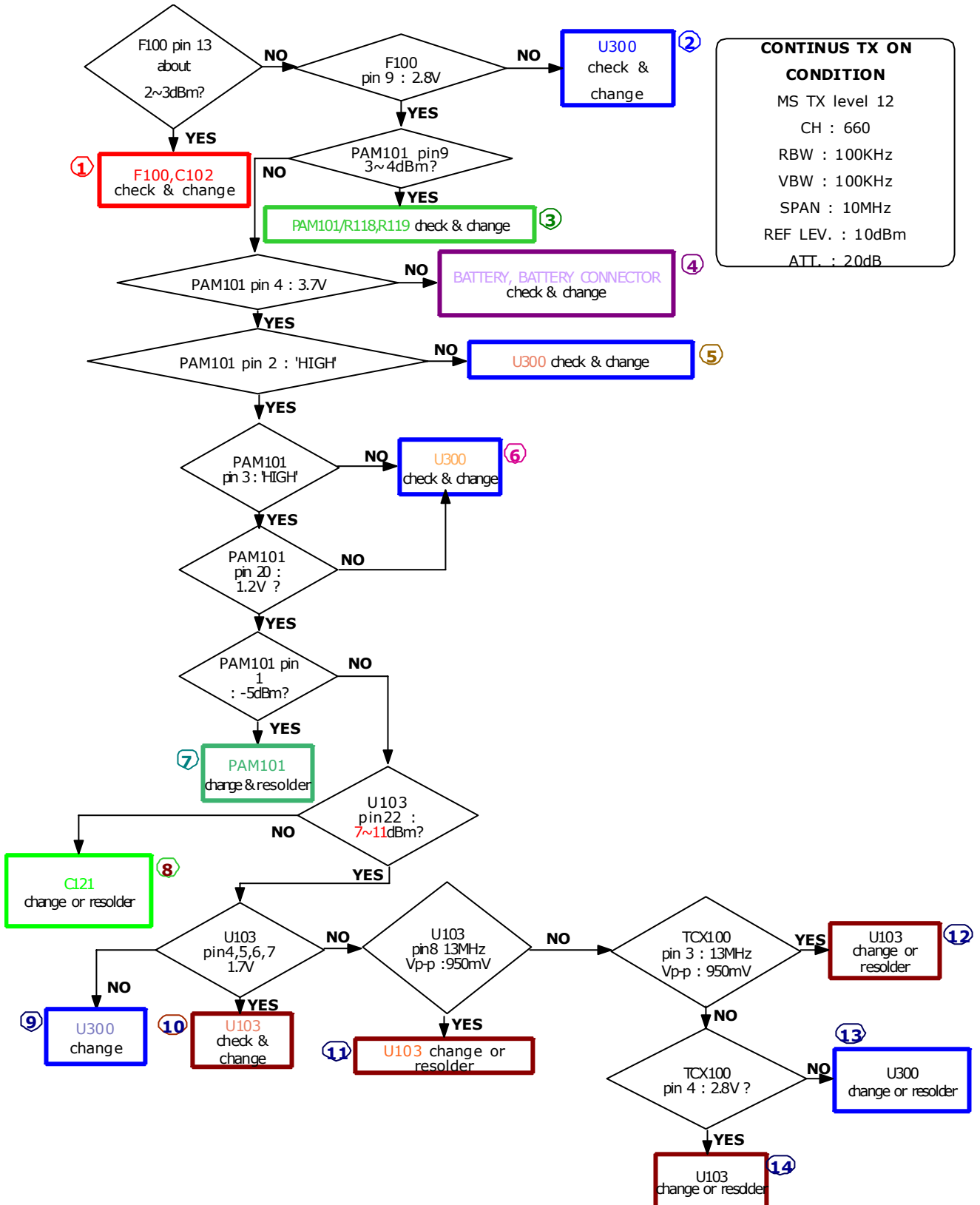

**CONTINUS TX ON
CONDITION**
 MS TX level 12
 CH : 660
 RBW : 100KHz
 VBW : 100KHz
 SPAN : 10MHz
 REF LEV. : 10dBm
 ATT. : 20dB

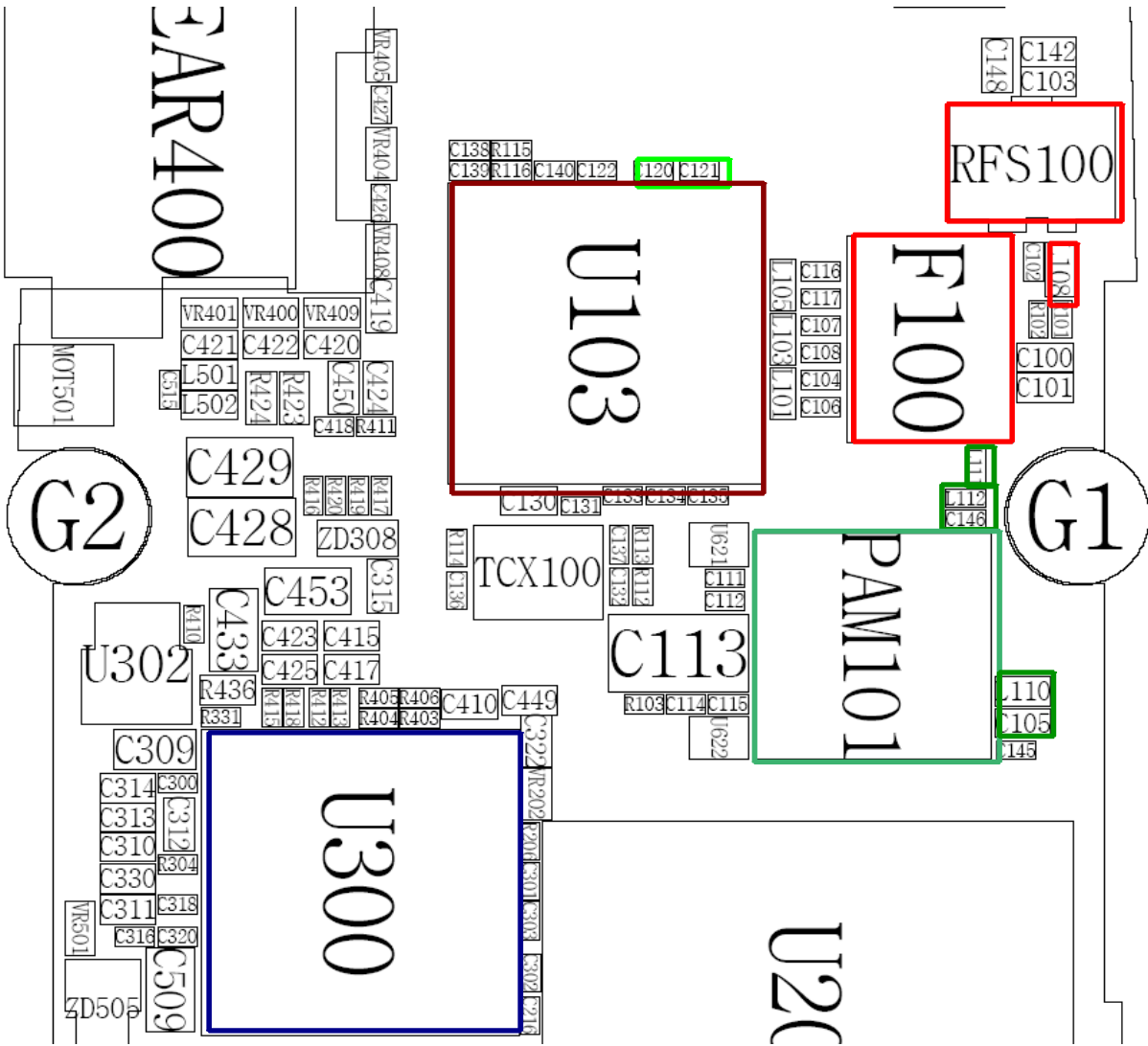

9-2-7. Bluetooth Part

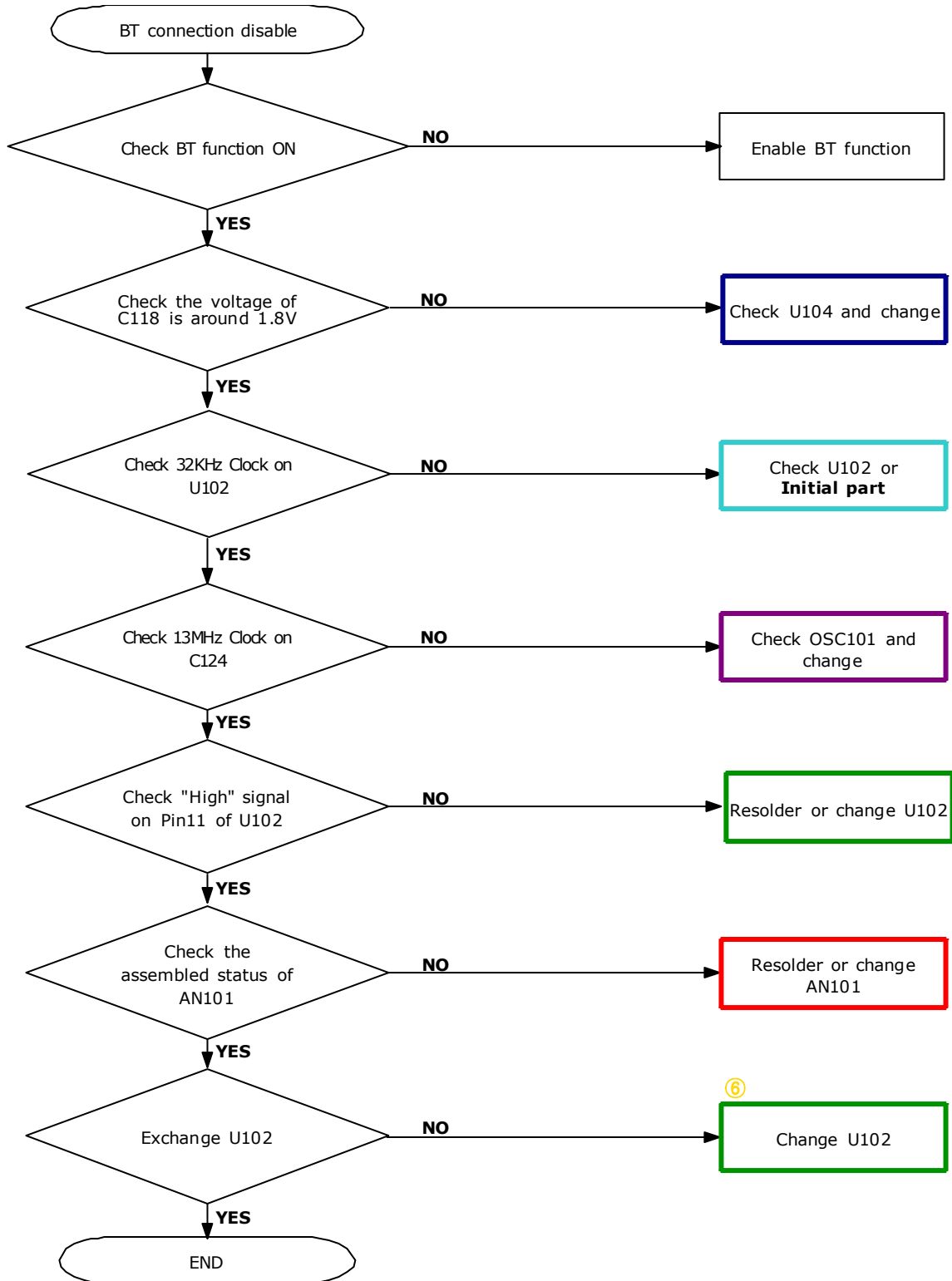

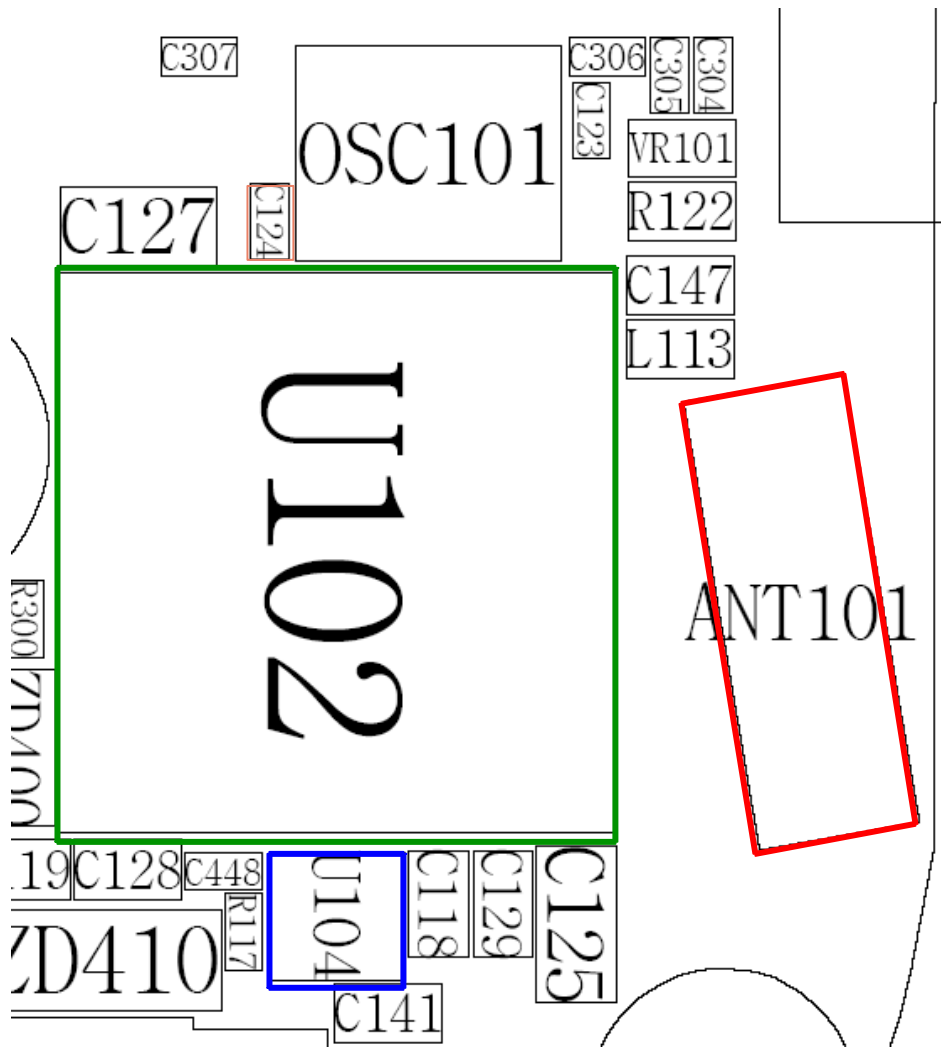

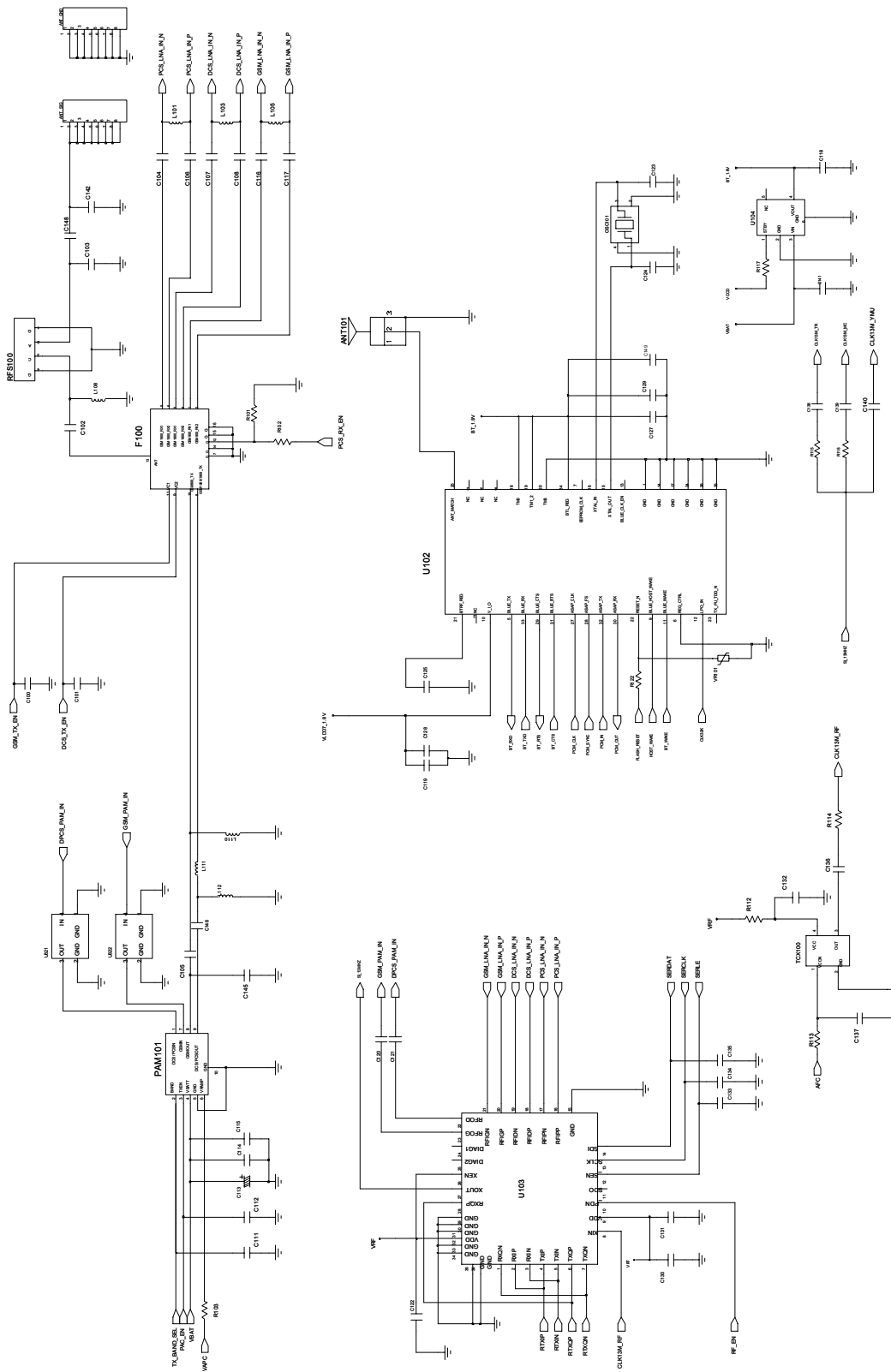

10. Reference data

10-1. Reference Abbreviate

AAC: Advanced Audio Coding.
AVC : Advanced Video Coding.
BER : Bit Error Rate
BPSK: Binary Phase Shift Keying
CA : Conditional Access
CDM : Code Division Multiplexing
C/I : Carrier to Interference
DMB : Digital Multimedia Broadcasting
EN : European Standard
ES : Elementary Stream
ETSI: European Telecommunications Standards Institute
MPEG: Moving Picture Experts Group
PN : Pseudo-random Noise
PS : Pilot Symbol
QPSK: Quadrature Phase Shift Keying
RS : Reed-Solomon
SI : Service Information
TDM : Time Division Multiplexing
TS : Transport Stream