

Trouble Shooting Guide, Mechanical

Applicable for K750

Contents

1	General	2
	1.1. Service functions in the software	2
	1.2. Misuse and other no warranty issues	3
2	Appearance Problems	6
3	Network/Signal Problems	9
4	On/Off Problems	10
5	Audio Problems	12
6	Key Problems	16
7	Display Problems	19
8	Illumination Problems	21
9	Alert Problems	23
10	SIM Problems	25
11	Charging/Capacity Problems	26
12	Camera Problems	27
13	Data Communication Problems	30
14	Hands-Free Problems	32
15	Software Problems	32
16	Revision History	33

1 General

This document outlines the mechanical repairs that should be made in an attempt to fix the common failures that are seen in the field. To gain a complete understanding of how to test and repair a specific failure, this document should be used in conjunction with the Test Instructions, Mechanical and the Working Instructions, Mechanical.

1.1. Service functions in the software

The service menu will be accessed with the following key combination. Use the joystick.

⇒*←←*←*

They are as follows:

Service info

Service tests

Text labels

The phones software has a built in service functionality that allows you to test some of the phones functions. (*See point 2 above*) It looks like this:

Main display

LED/illumination

Keyboard

Speaker

Earphone

Microphone

Vibrator

Camera

Flash LED

Memory Stick

Real time clock

FM radio (You need a headset to test)

Total call time

NOTE: Different names may occur depending on language setting and customization.

1.2. Misuse and other no warranty issues





Misuse is not covered by warranty. This chapter will explain what's not covered by warranty. Phones that have been exposed to misuse will not be covered by warranty.

This means: if it is possible to repair the phone, the customer will have to pay for the repair. SEMC will not allow any of these phones to be claimed into WCMS. Some local perspectives may interfere with this. Please reference to local directives.

1.1.1 Action

Make a general visual inspection for misuse.

Below are some **examples** of what is not covered by warranty.

				
Front window broken due to misuse.	LCD cracked due to drop.	Clear scratches	Mark after drop	Corrosion components on the PCB.

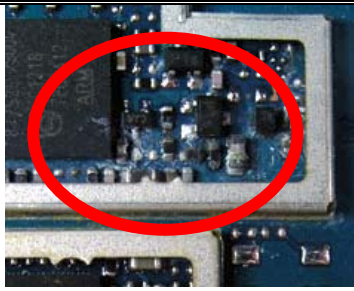
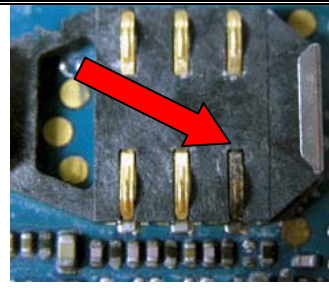
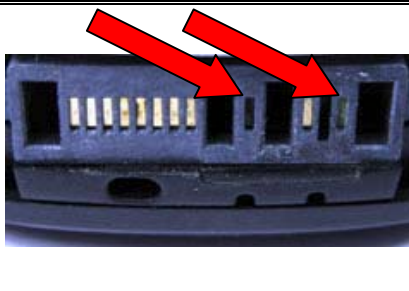
			
Corrosion components on the PCB.	Corrosion components on the PCB.	SIM reader damaged by liquid.	System connector damaged by liquid

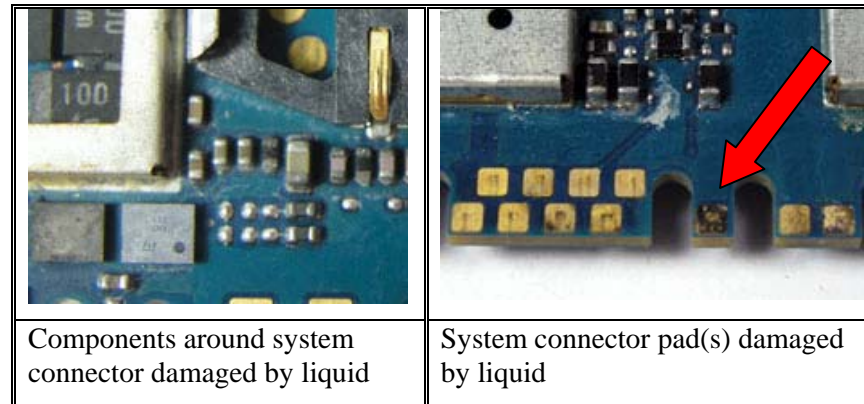

1.1.2 Liquid damage sticker

In the phone there is placed a sticker that can give you a hint to see if the phone is damage by liquid or not. This sticker is located near the SIM reader (Fig. 1.2.1) and it is possible to see it without disassemble the phone.

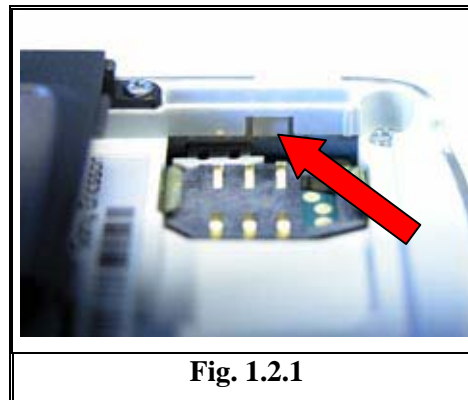

On the pictures below you will see the different between a sticker that has been in contact with liquid (Fig. 1.2.3) and with one that hasn't (Fig. 1.2.2).

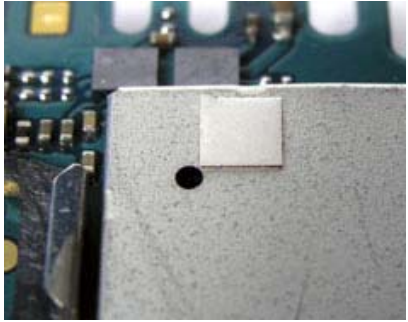
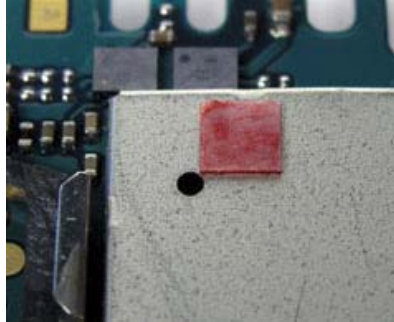
This sticker is ok	This sticker is <u>not</u> ok	
		<p>The white sticker that has been in contact with liquid turns into a red or pink sticker. In this case you should check the phone for liquid damage (<i>See point 1.1.1</i>).</p> <p>Note: There must be clear marks after liquid on the PCB before rejecting the phone for repair.</p>
Fig. 1.2.2	Fig. 1.2.3	

1.1.3 Action

Make a general visual inspection for misuse, corrosion or oxidation from liquid damage. No further action should be taken for a liquid damaged phone. Handle the unit according to local directives.

2 Appearance Problems

Problem Area	Items to Check	Repair Action	Reference Image
Appearance	Visually inspect the cosmetic quality of all user viewable surfaces Front System connector Joystick button Frame assembly IRDA window Memory card rubber lid Antenna cover assembly Battery cover assembly Co-brand inlay	<ul style="list-style-type: none"> • If dirty – Clean parts as necessary. • If unacceptably scratched or damaged – Replace damage parts as necessary. <p>NOTE: Misuse is not covered by warranty. Refer to chapter 1.2</p>	

Problem Area	Items to Check	Repair Action	Reference Image
	Visually inspect all keys Keyboard On/Off key Music key Volume key Camera key	<ul style="list-style-type: none"> • If dirty – Clean parts as necessary. • If unacceptably scratched or damaged – Replace damaged parts as necessary. <p>NOTE: Misuse is not covered by warranty. Refer to chapter 1.2</p>	



Problem Area	Items to Check	Repair Action	Reference Image
	Visually inspect for improper gap between seams	<ul style="list-style-type: none">• Reassemble or replace damaged parts as necessary.	

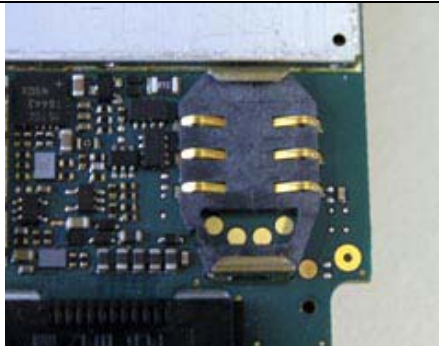
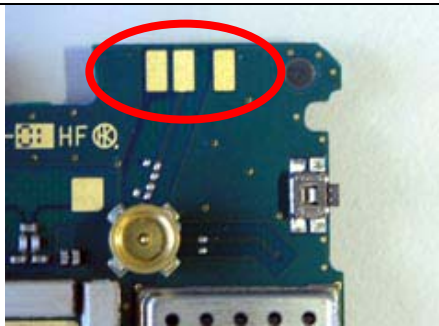

3 Network/Signal Problems

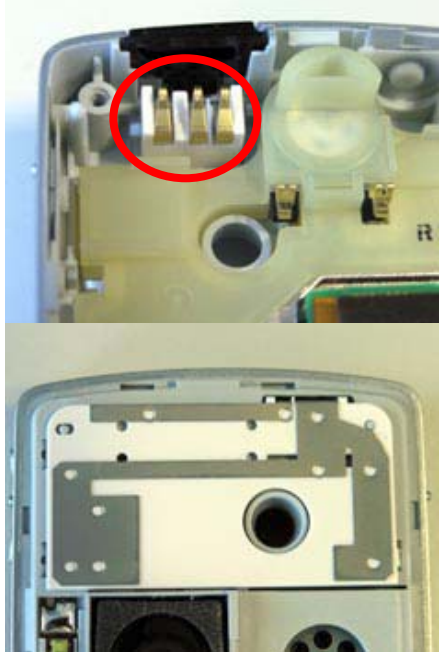
Problem Area	Items to Check	Repair Action	Reference Image
No Signal or Poor Signal	Before proceeding →	Perform a flash upgrade.	
	Visually inspect SIM holder	<ul style="list-style-type: none"> • If dirty or oxidized – Clean it. • If damaged – Send to an electrical repair location. 	
	Visually inspect antenna contact pads	<ul style="list-style-type: none"> • If dirty or oxidized – Clean the pads and replace the antenna assembly. 	



Problem Area	Items to Check	Repair Action	Reference Image
	Visually inspect antenna	<ul style="list-style-type: none"> • If dirty or oxidized – Replace it. • If damaged – Replace it. 	
	If the issue has not been resolved →	<ul style="list-style-type: none"> • Handle the unit according to local directives. 	

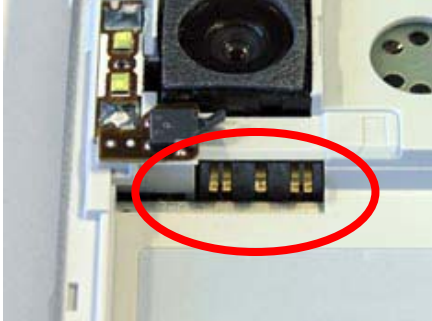

4 On/Off Problems



Problem Area	Items to Check	Repair Action	Reference Image
Power On problems	Check whether the phone vibrates 10 to 15 seconds after pressing the power key and whether the keypad illuminates	<ul style="list-style-type: none"> • If activation of the vibrator and keypad are detected, refer to the “Display Problems” section 	
	Before proceeding →	<ul style="list-style-type: none"> • Perform a flash upgrade. 	

Problem Area	Items to Check	Repair Action	Reference Image
	Visually inspect contact pads on battery	<ul style="list-style-type: none"> • If dirty or oxidized – Clean pads. • If damaged – Replace it. 	
	Visually inspect battery connector	<ul style="list-style-type: none"> • If dirty or oxidized – Clean it. • If damaged – Send to an electrical repair location. 	
	Visually inspect the power key	<ul style="list-style-type: none"> • If damaged – Replace it. 	
	If the issue has not been resolved →	<ul style="list-style-type: none"> • Handle the unit according to local directives. 	

5 Audio Problems

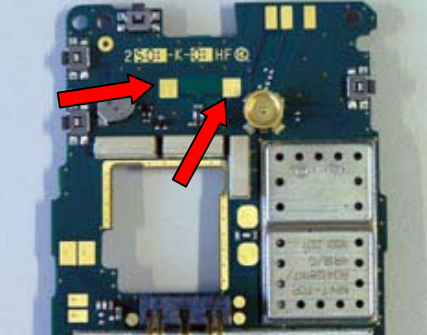
Problem Area	Items to Check	Repair Action	Reference Image
Microphone: No sound or poor	Before proceeding →	<ul style="list-style-type: none"> Perform a flash upgrade and a setting reset. 	
	Visually inspect the microphone's external port	<ul style="list-style-type: none"> If clogged - Clean or replace frame assembly. 	
	Visually inspect the microphone's dust cloth	<ul style="list-style-type: none"> If dirty or damaged – Replace frame assembly. 	
	If the issue has not been resolved →	<ul style="list-style-type: none"> Handle the unit according to local directives. 	
Speaker: No sound or poor	Before proceeding →	<ul style="list-style-type: none"> Perform a flash upgrade and a setting reset. 	

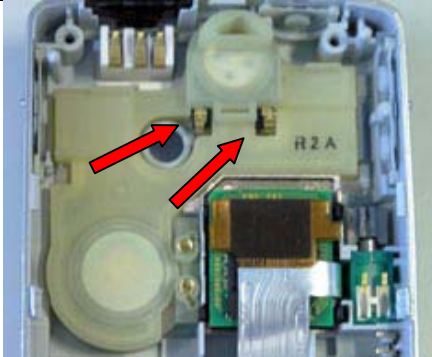

Problem Area	Items to Check	Repair Action	Reference Image
quality sound	Visually inspect speaker's external port	<ul style="list-style-type: none"> If clogged – Clean or replace front assembly. 	
	Visually inspect speaker's dust cloth	<ul style="list-style-type: none"> If dirty or damaged – Replace front cover. 	
	Visually inspect the speaker's contact pads on the PCB	<ul style="list-style-type: none"> If dirty or oxidized- Clean pads. 	

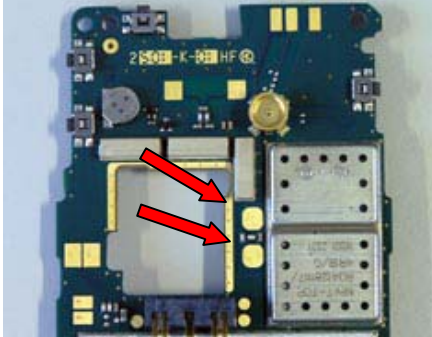
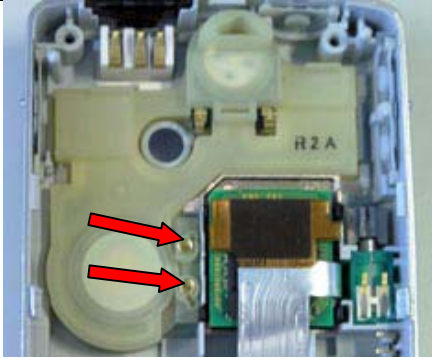
Problem Area	Items to Check	Repair Action	Reference Image
	Visually inspect the speaker pins	<ul style="list-style-type: none"> If damaged, dirty or oxidized – Replace speaker box. 	
	If the issue has not been resolved →	<ul style="list-style-type: none"> Replace speaker box. 	
	If the issue has not been resolved →	<ul style="list-style-type: none"> Handle the unit according to local directives. 	
Poly.-Speaker: No sound or poor quality sound	Before proceeding →	<ul style="list-style-type: none"> Perform a flash upgrade and a setting reset. 	
	Visually inspect speaker's external port	<ul style="list-style-type: none"> If clogged – Clean or replace antenna cover. 	

Problem Area	Items to Check	Repair Action	Reference Image
	Visually inspect the speaker's dust cloth	<ul style="list-style-type: none"> If dirty or damaged - Replace antenna cover. 	
	Visually inspect the speaker's contact pads on the PCB	<ul style="list-style-type: none"> If dirty or oxidized- Clean pads. 	
	Visually inspect the speaker pins	<ul style="list-style-type: none"> If damaged, dirty or oxidized – Replace speaker box. 	
	If the issue has not been resolved →	<ul style="list-style-type: none"> Replace speaker box. 	
	If the issue has not been resolved →	<ul style="list-style-type: none"> Handle the unit according to local directives. 	

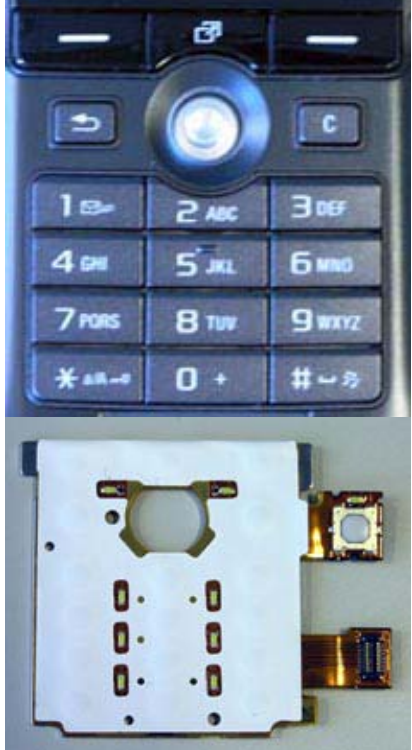
6 Key Problems

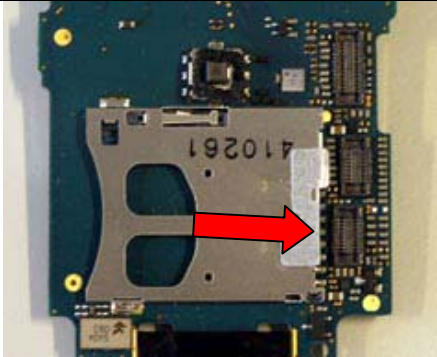
Problem Area	Items to Check	Repair Action	Reference Image
<p>Keyboard:</p> <p>A key on the keyboard is not functioning or is intermittent</p>	<p>Visually inspect for debris between keyboard and keyboard foil, and for damage to the keyboard and the keyboard foil.</p> <p>NOTE: Camera switch is located on the keyboard foil.</p> <p>NOTE: Camera switch is a dual switch.</p>	<ul style="list-style-type: none"> • If dirty – Clean both parts. • If damaged - Replace keypad and/or keyboard foil as necessary. 	

Problem Area	Items to Check	Repair Action	Reference Image
	Visually inspect whether the keyboard flex film is properly connected to its connector on the PCB	<ul style="list-style-type: none"> If improperly connected – Re-establish proper connection. 	
	If the issue has not been resolved →	<ul style="list-style-type: none"> Replace the keyboard foil, if it has not already been replaced. 	
	If the issue has not been resolved →	<ul style="list-style-type: none"> Handle the unit according to local directives. 	
Joystick:	Visually inspect the joystick button	<ul style="list-style-type: none"> If dirty or damaged – Replace it. 	

Problem Area	Items to Check	Repair Action	Reference Image
Side keys	Visually inspect for damage to the side keys Volume keys Music key Camera key On/Off key	<ul style="list-style-type: none"> If damaged - Replace keys as necessary. 	
	If the issue has not been resolved →	<ul style="list-style-type: none"> Handle the unit according to local directives. 	

7 Display Problems

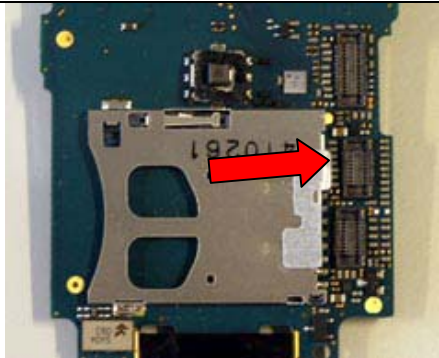
Problem Area	Items to Check	Repair Action	Reference Image
LCD problem	Check whether the phone vibrates 10 to 15 seconds after pressing the power key and whether the keypad illuminates	<ul style="list-style-type: none"> If activation of the vibrator are not detected, refer to the On/Off Problems” chapter 2 	
	Before proceeding →	<ul style="list-style-type: none"> Perform a flash upgrade and a setting reset. 	
	Visually inspect whether the LCD flex film is properly connected to its connector on the PCB	<ul style="list-style-type: none"> If improperly connected – Re-establish proper connection. 	

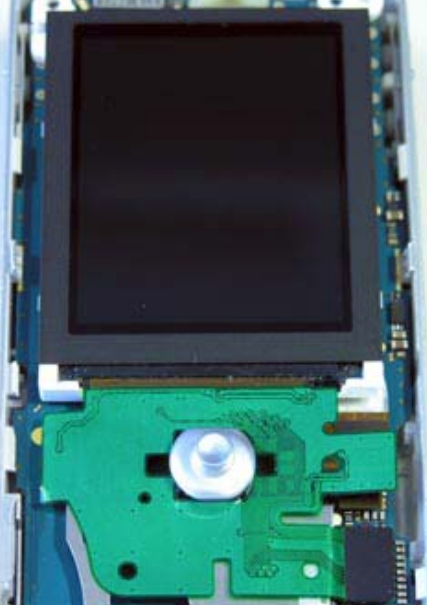
Problem Area	Items to Check	Repair Action	Reference Image
	If the issue has not been resolved →	<ul style="list-style-type: none"> • Replace the LCD. 	

8 Illumination Problems

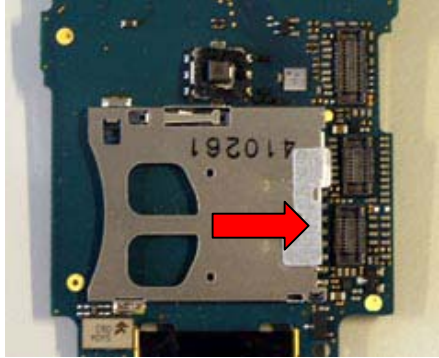
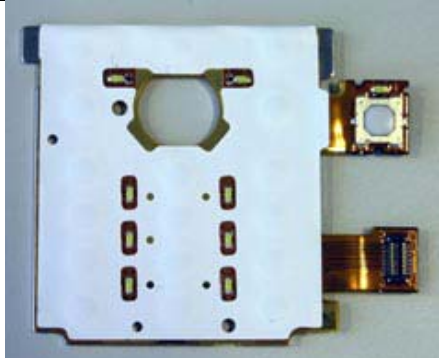
Problem Area	Items to Check	Repair Action	Reference Image
Keys: The entire keypad or a portion of the keypad does not illuminate.	Before proceeding →	<ul style="list-style-type: none"> Perform a flash upgrade and a setting reset. 	
	Visually inspect whether the keyboard flex film is properly connected to its connector on the PCB	<ul style="list-style-type: none"> If improperly connected – Re-establish proper connection. 	
	Visually inspect the keyboard foil.	<ul style="list-style-type: none"> If dirty or oxidized – Replace it. If damaged – Replace it. 	
	If the issue has not been resolved →	<ul style="list-style-type: none"> Replace the keypad and the keyboard foil. 	
	If the issue has not been resolved →	<ul style="list-style-type: none"> Handle the unit according to local directives. 	
LCD	Before proceeding →	<ul style="list-style-type: none"> Perform a flash upgrade and a setting reset. 	

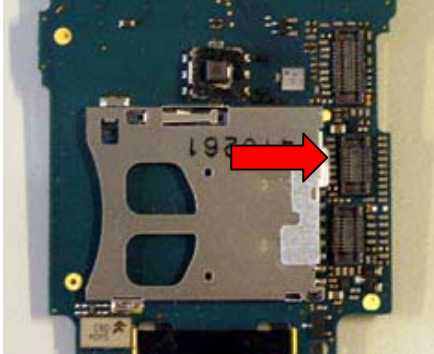
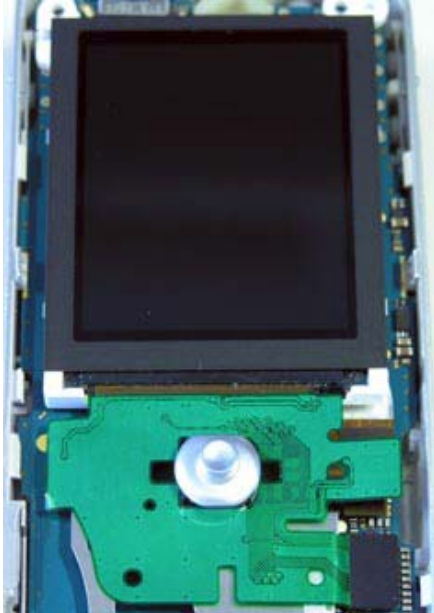
Problem Area	Items to Check	Repair Action	Reference Image
	Visually inspect whether the LCD flex film is properly connected to its connector on the PCB	<ul style="list-style-type: none"> If improperly connected – Re-establish proper connection. 	
	If issue has not been resolved →	<ul style="list-style-type: none"> Replace the LCD. 	
	If the issue has not been resolved →	<ul style="list-style-type: none"> Handle the unit according to local directives. 	

9 Alert Problems

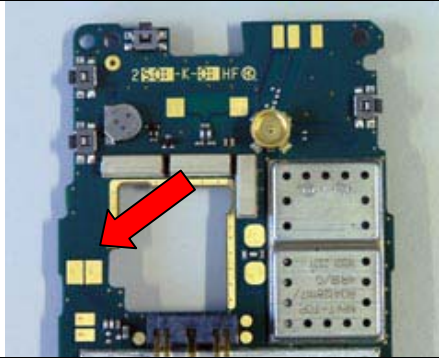
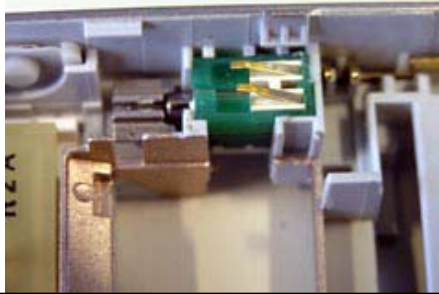
Problem Area	Items to Check	Repair Action	Reference Image
Vibrator:	Before proceeding →	<ul style="list-style-type: none"> Perform a flash upgrade and a setting reset. 	
	Visually inspect the vibrator contact pads on the PCB	<ul style="list-style-type: none"> If dirty or oxidized – Clean them. 	
Poly.-Speaker:	Before proceeding →	<ul style="list-style-type: none"> Perform a flash upgrade and a setting reset. 	
	Visually inspect the vibrator	<ul style="list-style-type: none"> If dirty or oxidized – Replace it. If damaged - Replace it. 	

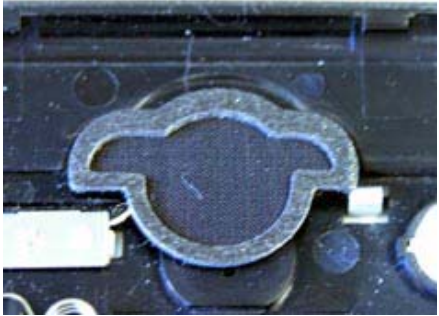
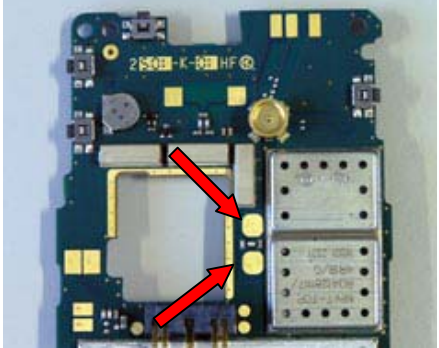

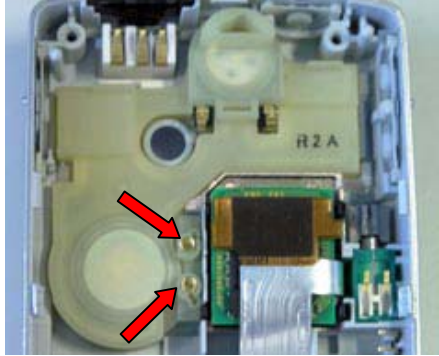
Problem Area	Items to Check	Repair Action	Reference Image
No sound or poor quality sound	Visually inspect speaker's external port	<ul style="list-style-type: none"> If clogged – Clean it. 	
	Visually inspect the speaker's dust cloth	<ul style="list-style-type: none"> If dirty or damaged - Replace antenna cover. 	
	Visually inspect the speaker's contact pads on the PCB	<ul style="list-style-type: none"> If dirty or oxidized- Clean pads. 	

Problem Area	Items to Check	Repair Action	Reference Image
	Visually inspect the speaker pins	<ul style="list-style-type: none"> If damaged, dirty or oxidized – Replace speaker box. 	
	If the issue has not been resolved →	<ul style="list-style-type: none"> Replace speaker box. 	
	If the issue has not been resolved →	<ul style="list-style-type: none"> Handle the unit according to local directives. 	

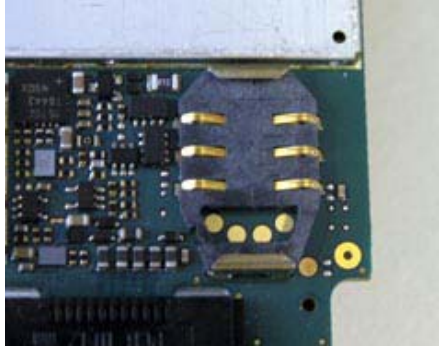
10 SIM Problems

Problem Area	Items to Check	Repair Action	Reference Image
SIM undetected (Insert SIM)	Inspect SIM holder	<ul style="list-style-type: none"> If dirty or oxidized – Clean. If damaged – Send to an electrical repair location. 	
Unit indicates the incorrect SIM is inserted (Insert correct SIM)	Check whether the phone is locked to a particular carrier and whether the correct carrier's SIM is being used	<ul style="list-style-type: none"> Use Correct Carrier SIM or test SIM. 	
	If the issue has not been resolved →	<ul style="list-style-type: none"> Handle the unit according to local directives. 	

11 Charging/Capacity Problems



Problem Area	Items to Check	Repair Action	Reference Image
Battery will not charge	Visually inspect the contact pads of the battery	<ul style="list-style-type: none"> • If dirty or oxidized – Clean. • If damaged – Replace battery. 	
	Visually inspect the of the battery connector	<ul style="list-style-type: none"> • If dirty or oxidized – Clean. • If damaged – Send to an electrical repair location. 	
	Visually inspect the system connector	<ul style="list-style-type: none"> • If dirty or oxidized – Replace the system connector. • If damaged – Replace the system connector. 	

Battery loses charge quickly/ standby time seems short	Before proceeding →	<ul style="list-style-type: none"> Perform a flash upgrade and a setting reset. 	
	If the issue has not been resolved →	<ul style="list-style-type: none"> Replace battery. 	
	If the issue has not been resolved →	<ul style="list-style-type: none"> Handle the unit according to local directives. 	

12 Camera Problems

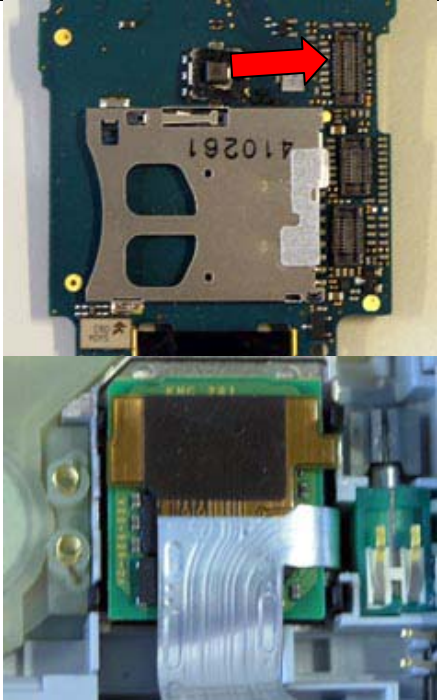

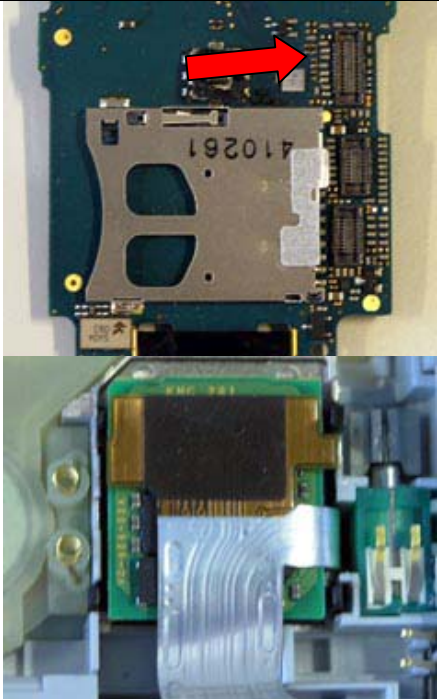
Problem Area	Items to Check	Repair Action	Reference Image
Lines, marks, blurred or discolored picture	Visually inspect the camera lens	<ul style="list-style-type: none"> If dirty – Clean camera lens. If scratched or damaged – Replace the camera module. 	



Problem Area	Items to Check	Repair Action	Reference Image
	Visually inspect whether the camera flex film is properly connected to its connector on the PCB and on the camera	<ul style="list-style-type: none"> • If improperly connected – Re-establish proper connection. 	
	Visually inspect camera flex film	<ul style="list-style-type: none"> • If dirty or oxidized – Replace it. • If damaged – Replace it. 	
	If the issue has not been resolved →	<ul style="list-style-type: none"> • Replace the camera module and the camera flex. 	
Will not capture an image	Visually inspect for debris between and/or damage to the camera key and the keyboard foil.	<ul style="list-style-type: none"> • If dirty – Clean both parts. • If damaged - Replace the camera key and/or the keyboard foil as necessary. 	
	Visually inspect whether the keyboard foil is properly connected to its connector on the circuit board	<ul style="list-style-type: none"> • If improperly connected – Re-establish proper connection. 	

Problem Area	Items to Check	Repair Action	Reference Image
	Visually inspect whether the camera flex film is properly connected to its connector on the PCB and on the camera	<ul style="list-style-type: none"> If improperly connected – Re-establish proper connection. 	
	If the issue has not been resolved →	<ul style="list-style-type: none"> Replace the keyboard foil if it has not already been replaced. 	
	If the issue has not been resolved →	<ul style="list-style-type: none"> Replace camera module. 	

Problem Area	Items to Check	Repair Action	Reference Image
	If the issue has not been resolved →	<ul style="list-style-type: none"> Handle the unit according to local directives. 	

13 Data Communication Problems

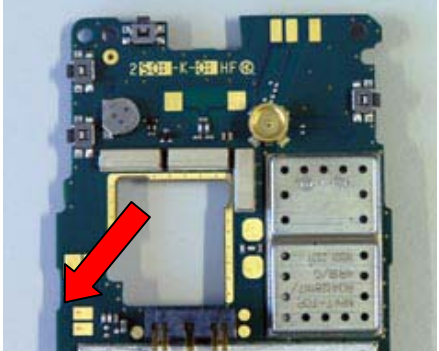
Problem Area	Items to Check	Repair Action	Reference Image
Problem transferring data using a direct connection	Visually inspect the system connector	<ul style="list-style-type: none"> If dirty or oxidized – Replace it. If damaged – Replace it. 	
Will not connect with a functional IR device	Visually inspect the IRDA window for dirt, scratches, and damage	<ul style="list-style-type: none"> If dirty – Clean it. If damaged – Replace it. 	

<p>Will not connect with a functional Bluetooth device</p>	<p>Visually inspect the Bluetooth antenna contact pads on the PCB</p>	<ul style="list-style-type: none"> • If dirty or oxidized – Clean it. 	
	<p>Visually inspect the Bluetooth antenna</p>	<ul style="list-style-type: none"> • If dirty or oxidized – Replace it. • If damaged – Replace it. 	
	<p>If the issue has not been resolved →</p>	<ul style="list-style-type: none"> • Handle the unit according to local directives. 	

14 Hands-Free Problems

Problem Area	Items to Check	Repair Action	Reference Image
Hands-free not working	Visually inspect the system connector	<ul style="list-style-type: none"> • If dirty or oxidized – Replace it. • If damaged – Replace it. 	
	If the issue has not been resolved →	<ul style="list-style-type: none"> • Handle the unit according to local directives. 	

15 Software Problems

- If there are problems with the response of the keypad commands, or spelling errors in the menu, if they are not related to mechanical damage, make a master reset and flash the phone with the latest software from EMMA III.
- Checking the software revision can be done in the Service info, see chapter *Service functions in the software*.
Choose: Service info / SW information.
The Software revision and date will be shown in the display.

Note: Do a SW upgrade before sending the unit to a higher level. Do **not** scrap a phone that hasn't been upgraded.

If the failure still occurs, handle the unit according to the local directives.

16 Revision History

Rev.	Date	Changes / Comments
A	2005-05-13	First draft
B	2005-05-17	Due to system problem
C	2005-05-19	Due to system problem