

Service Schematics

Introduction

Important:

This document is intended for use by authorized service centers only.

“Service Schematics“ was created with focus on customer care. The purpose of this document is to provide further technical repair information for NOKIA mobile phones on Level 3/4 service activities. It contains additional information such as e.g. “Component finder”, “Frequency band table” or “Antenna switch table”. The “Signal overview” page gives a good and fast overview about the most important signals and voltages on board. Saving process time and improving the repair quality is the aim of this document. It is to be used additionally to the service manual and other training or service information such as Service Bulletins.

All measurements were made using following equipment:

Nokia repair SW	:	Phoenix version 2006.04.6.130
Oscilloscope	:	Fluke PM 3380A/B
Spectrum Analyzer	:	Advanced R3162 with an analog probe
RF-Generator/GSM Tester	:	Rhode & Schwarz CMU 200
Multimeter	:	Fluke 73 Series II

While every endeavour has been made to ensure the accuracy of this document, some errors may exist. If the reader finds any errors, NOKIA shall be notified in writing.

Please send E-Mail to: training.sace@nokia.com

Copyright © NOKIA

This material, including documentation and any related computer programs is protected by copyright, controlled by NOKIA. All rights are reserved. Copying, including reproducing, modifying, storing, adapting or translating any or all of this material requires the prior written consent of NOKIA. This material also contains confidential information, which may not be disclosed to others without the prior written consent of NOKIA.

NOKIA

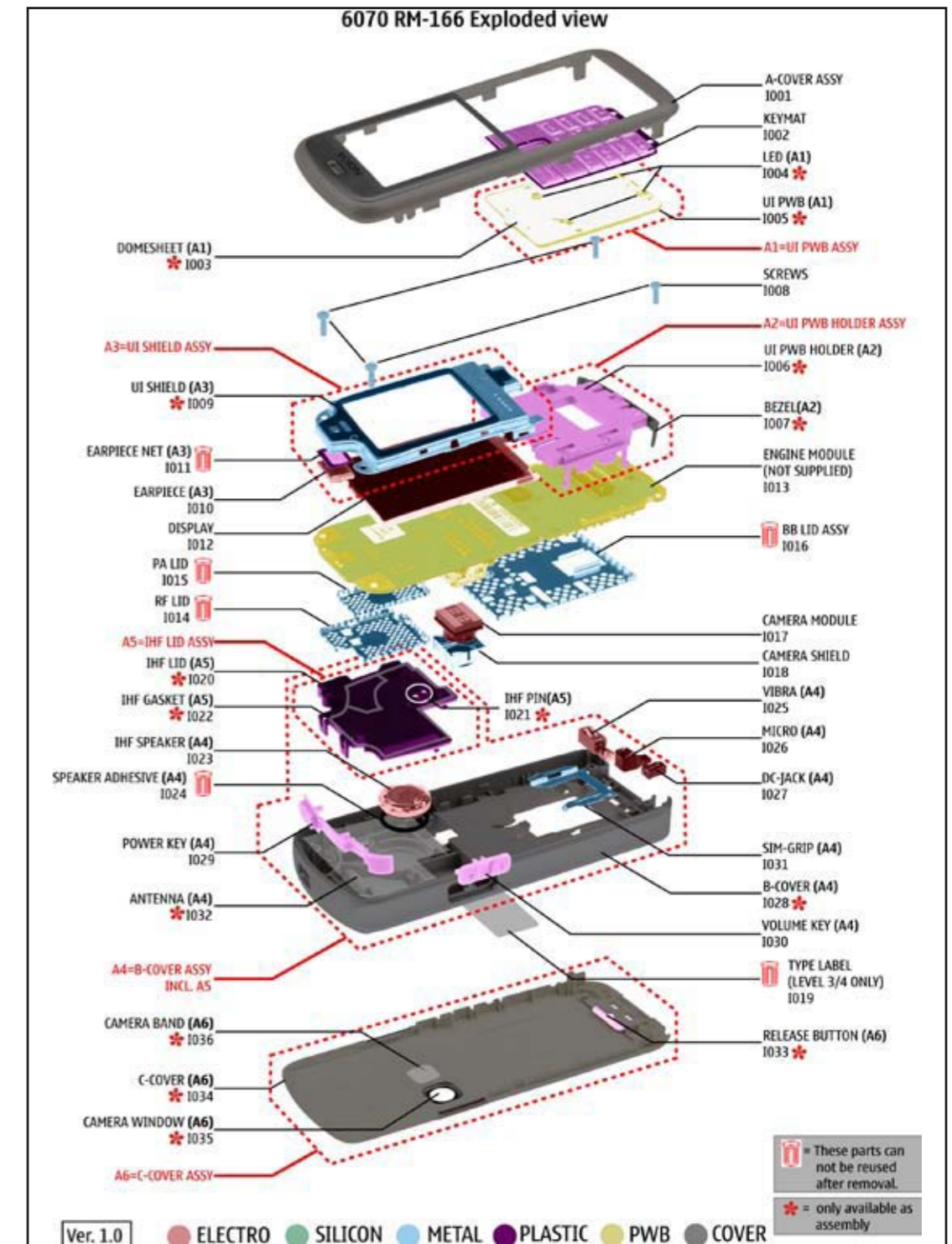
6070

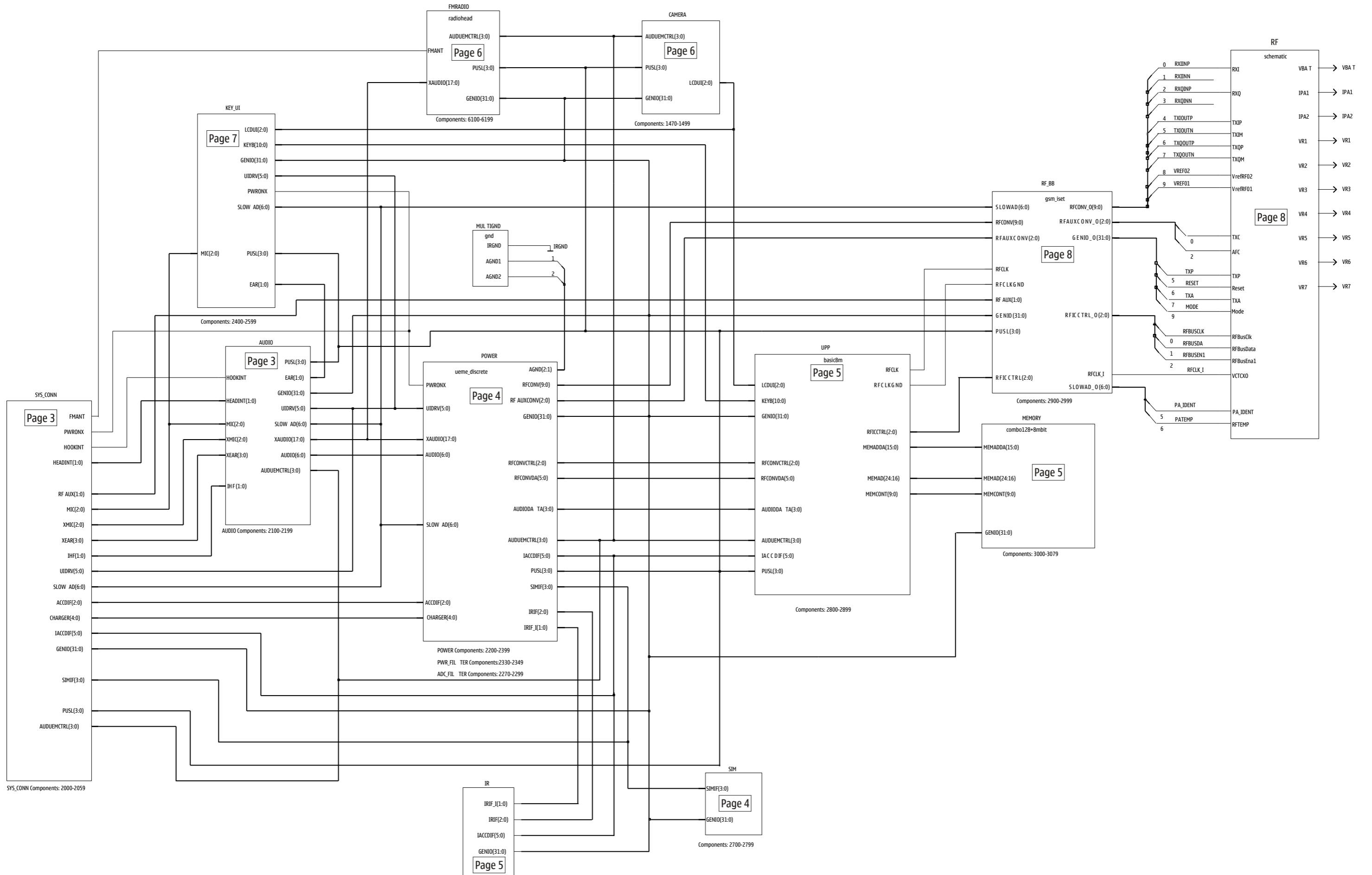
RM-166/167

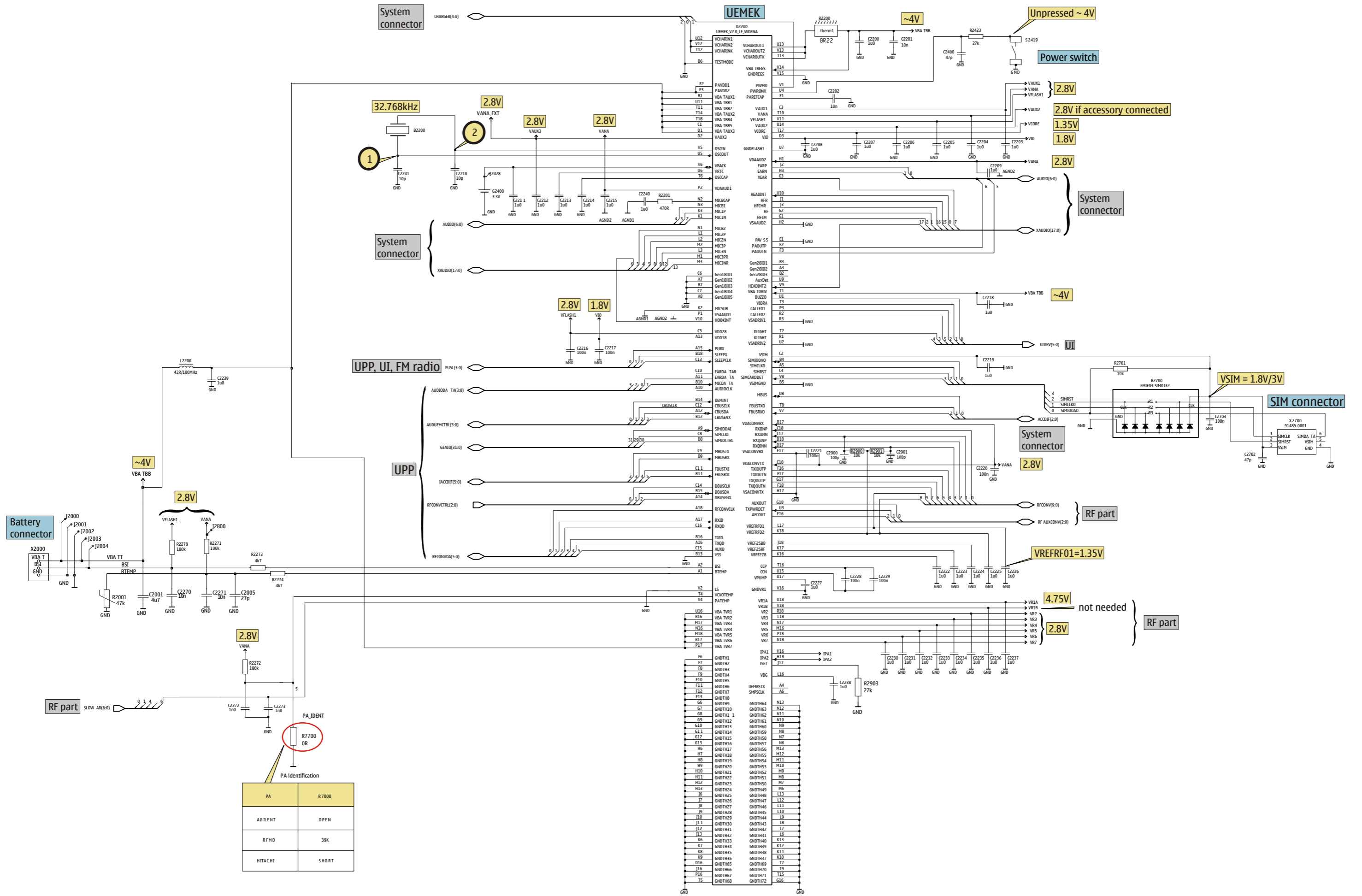


Table of contents	
Frontpage	1
DCT-4 common baseband	2
Sytem connector & Audio	3
UEME & SIM	4
UPP, Combo memory & IrDA	5
FM Radio & Camera	6
UI, Vibra & Key PWB	7
RF part	8
Signal overview	9
Component finder - engine	10
Component finder - keyboard	11

Exploded view and component disposal

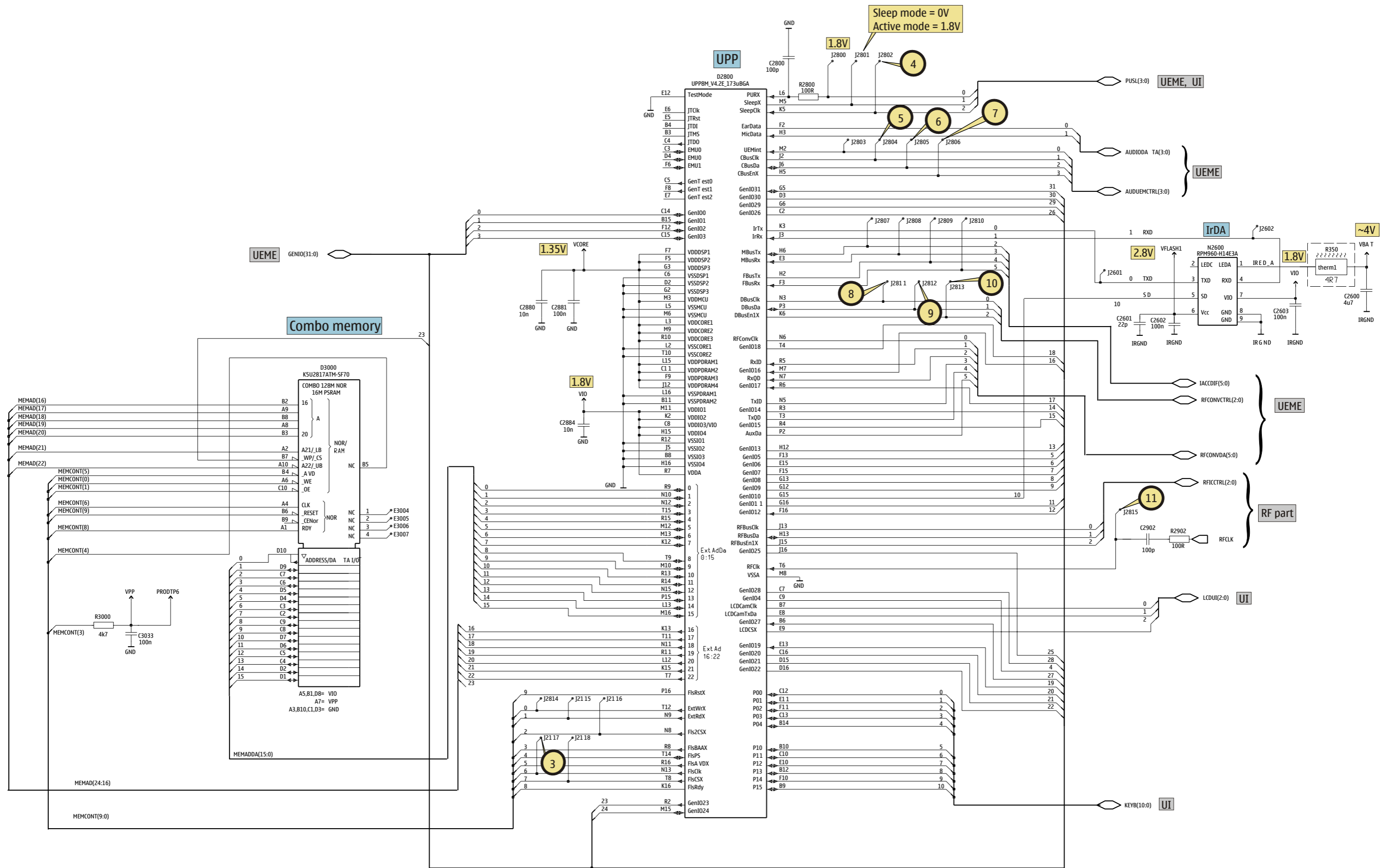


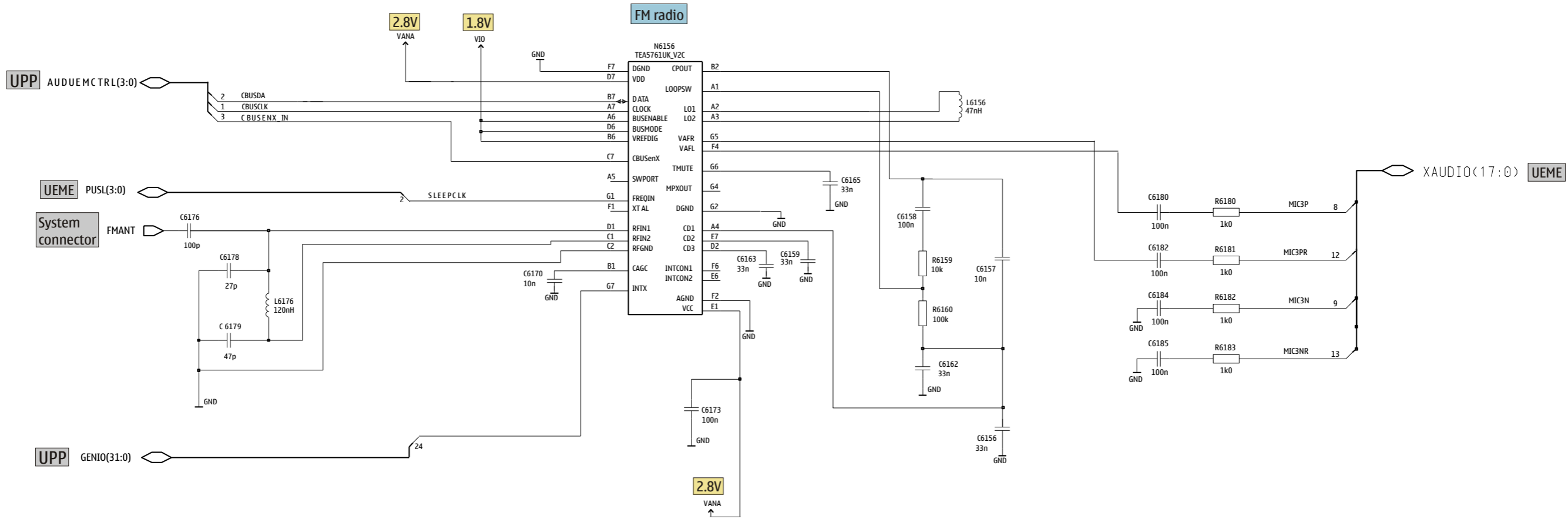




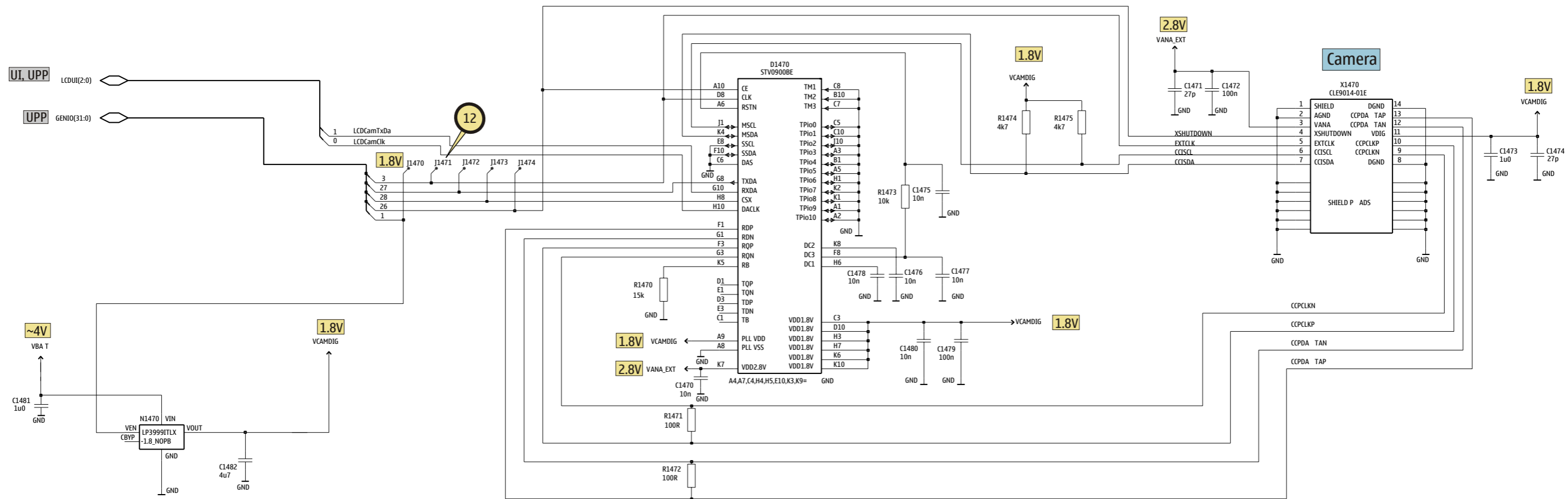
PA Identification

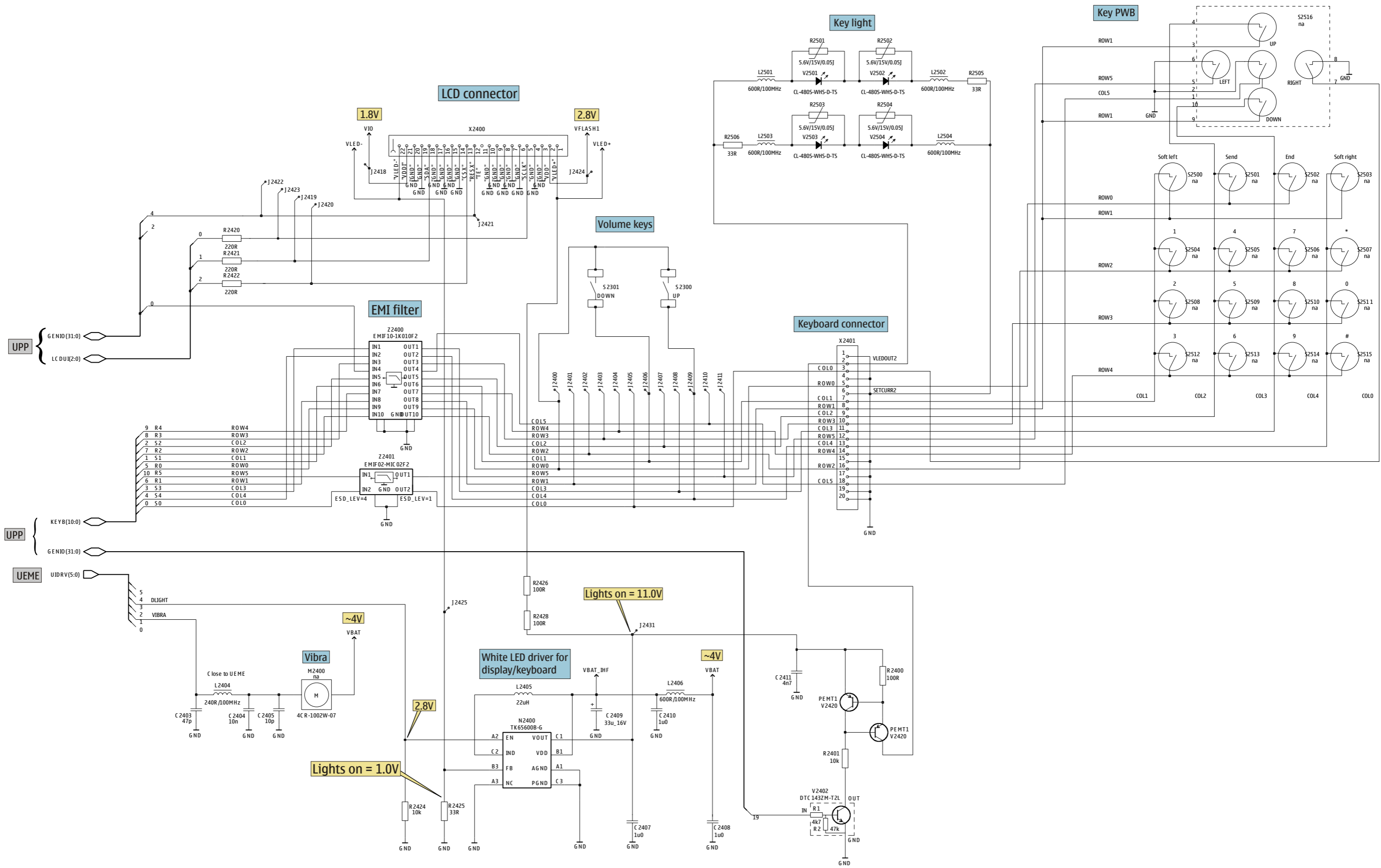
PA	R 7000
AGLENT	OPEN
RFMD	39K
HTACH1	SHORT

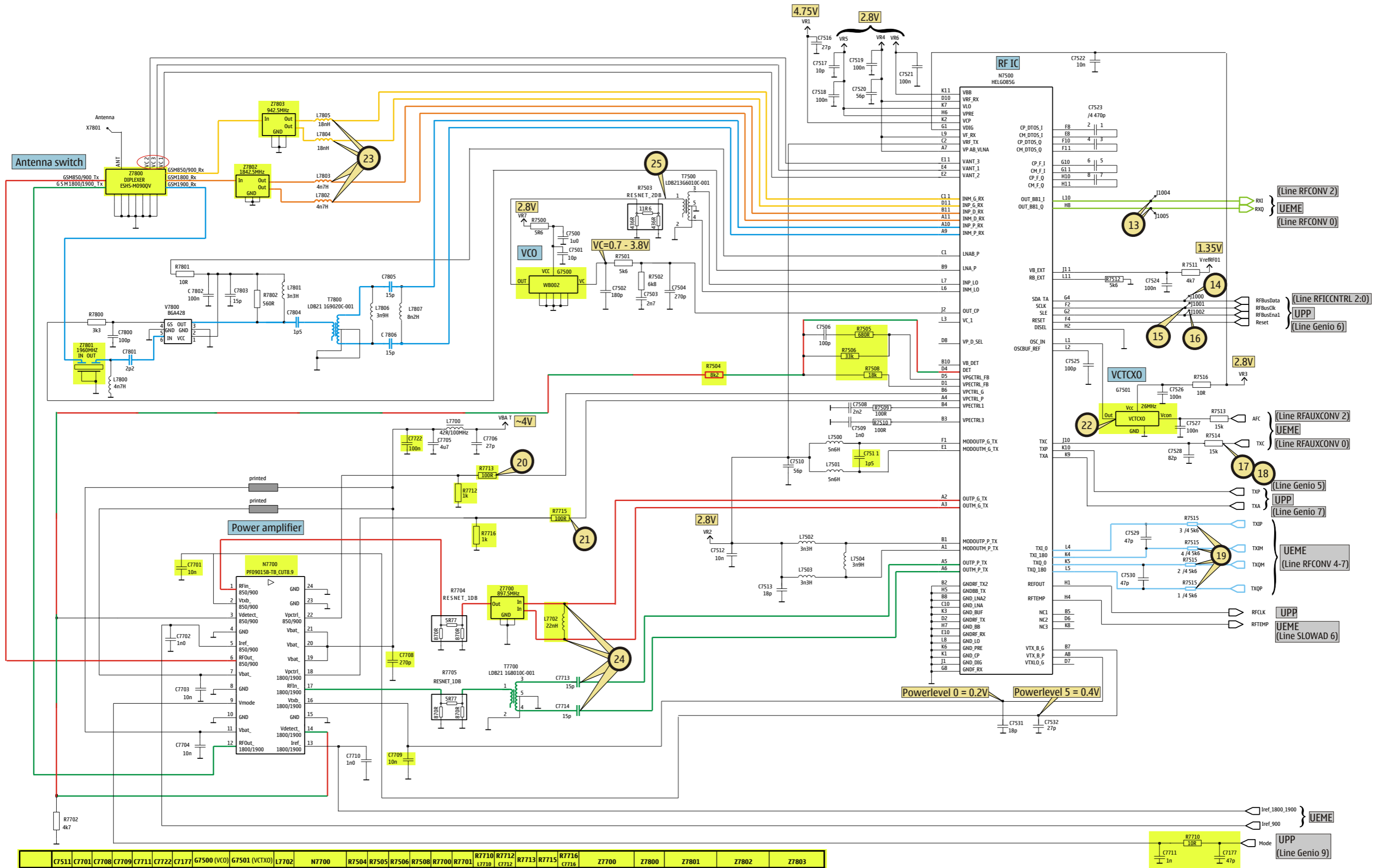




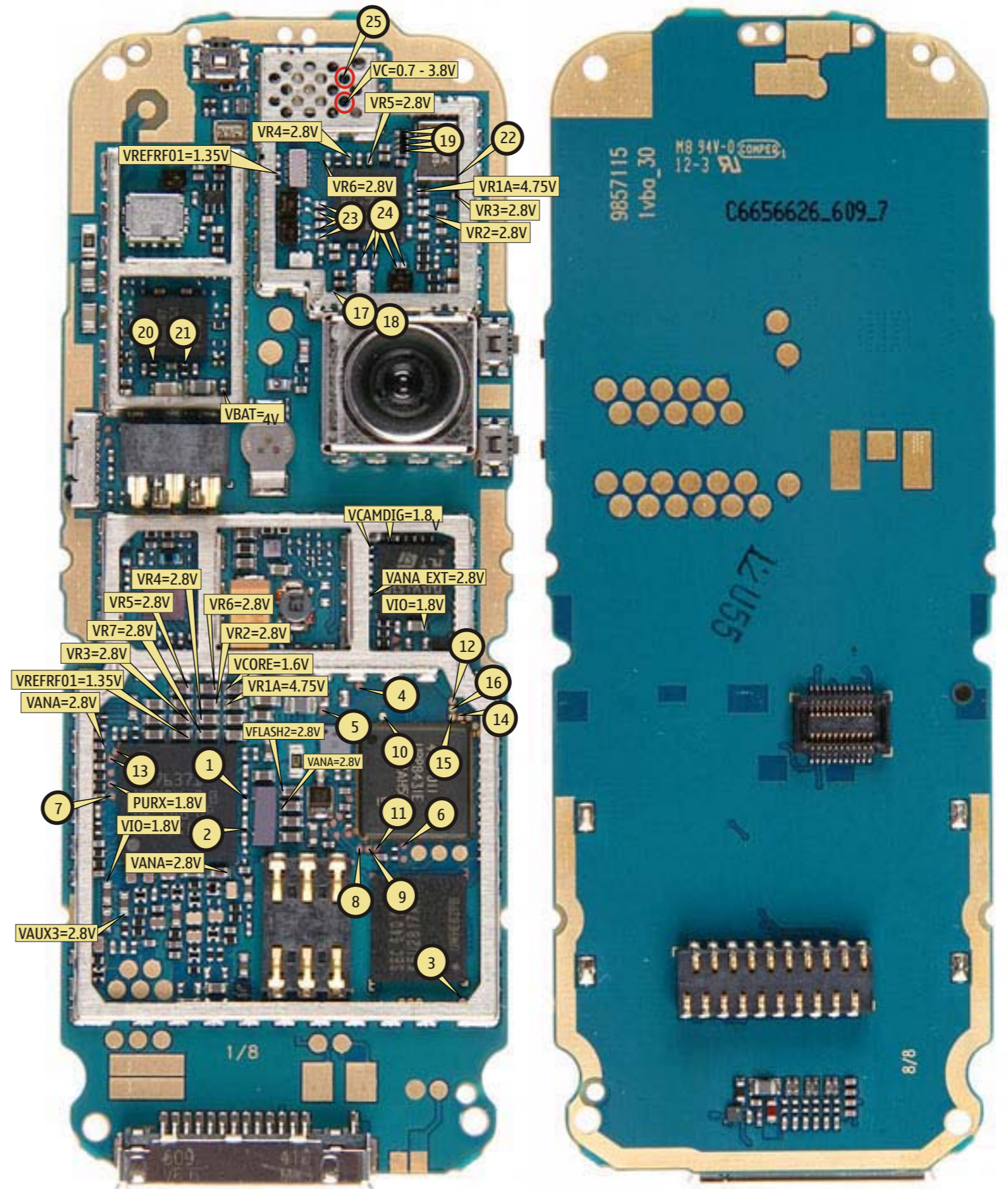
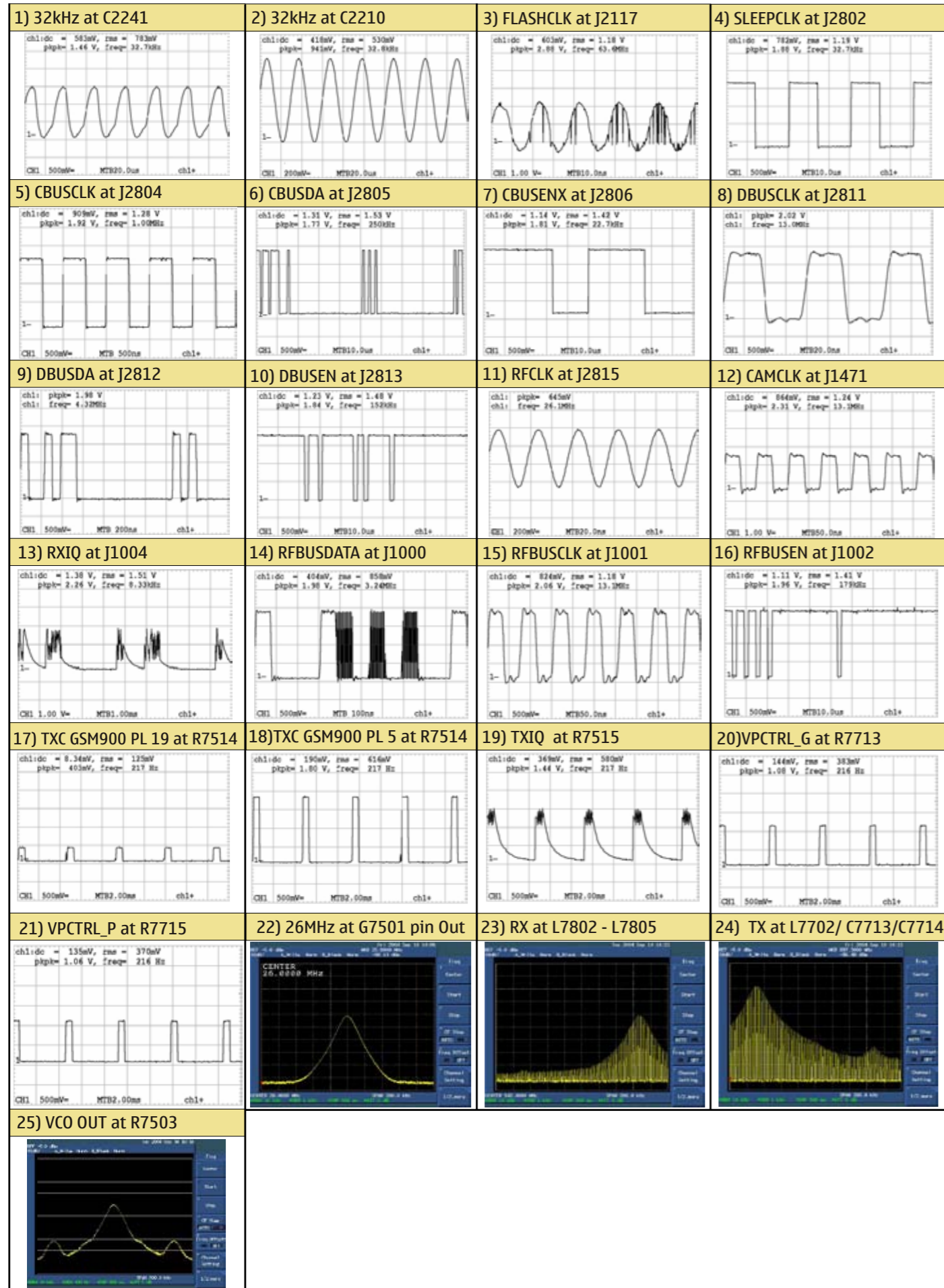
HW accelerator



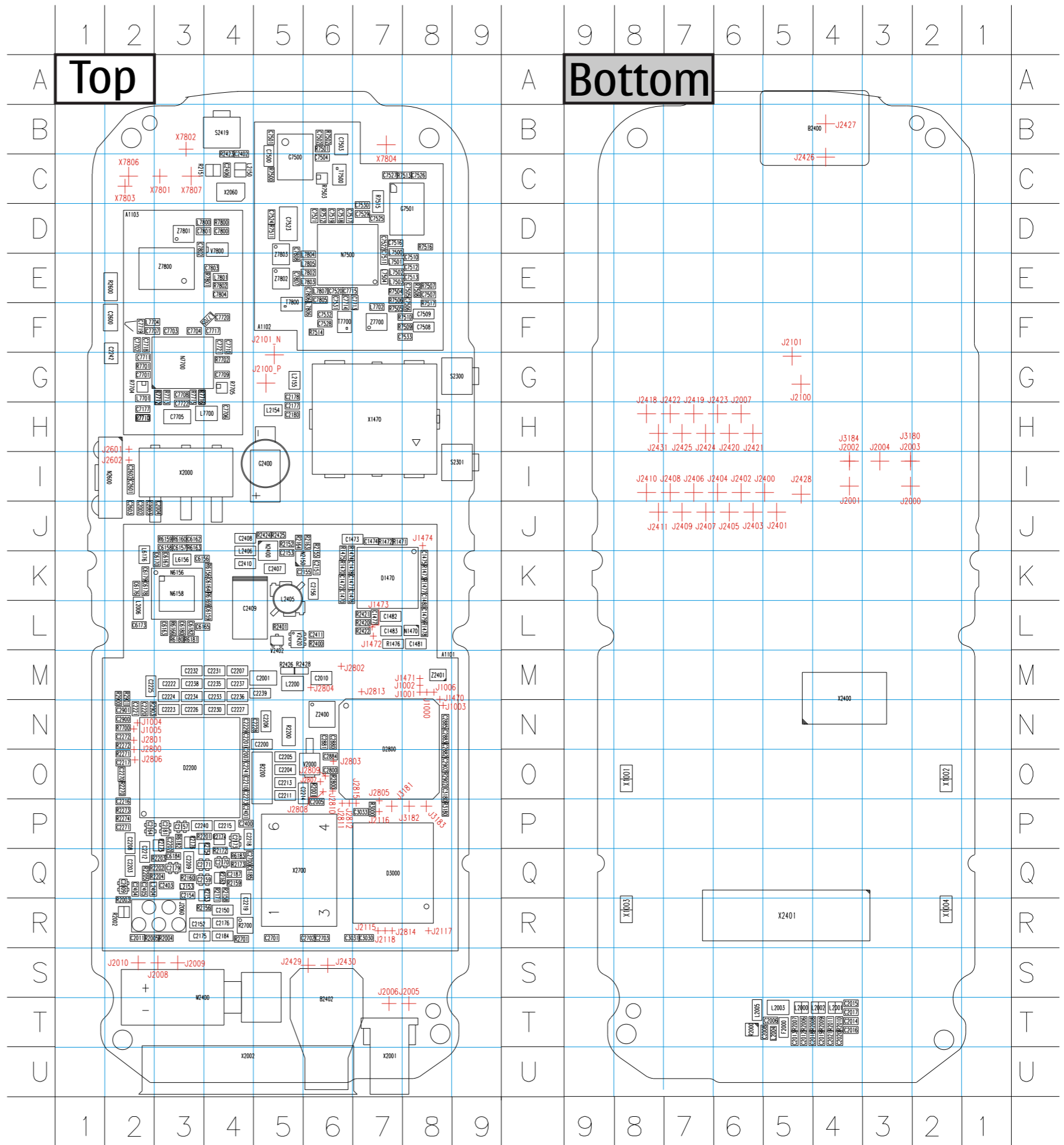




	C7511	C7701	C7708	C7709	C7711	C7712	C7717	G7500 (VCO)	G7501 (VCTCXO)	L7702	N7700	R7504	R7505	R7506	R7508	R7700	R7701	R7710 (C7710)	R7712 (C7712)	R7713	R7715	R7716 (C7716)	Z7700	Z7800	Z7801	Z7802	Z7803
EU BOM1	1p5	100n	270p	10n	1n	100n	47p	FDK WB002G	Toyocom TC0-914 T	22nH	RFMD PF09015B-cut 8.9	8k2	680	33k	18k	0R	na	10	1k	100R	100R	1k	Epos 89012	Hitachi M0900V	Epos 89008	Epos 89018	Epos 89017
EU BOM2	1p2	na	10n	na	na	na	na	Matsushita ENFVZ7095	NDK NKG3138D	33nH	RFMD PA RF9250 ver 5.1	4k7	4k7	22k	10k	39k	1k	3n9	10n	33R	33R	10n	SAFEK897MFM0F04	Murata DA269	Murata SAFEK1G96K80F04	Murata SAFEK1G84FC0F04	Murata SAFEK942MFL0F04
EU BOM2B	1p2	na	10n	na	na	na	47p	FDK WB002G	Kyocera KT20a	33nH	RFMD PA RF9250 ver 5.1	4k7	4k7	22k	10k	39k	1k	3n9	10n	33R	33R	10n	SAFEK897MFM0F04	Murata DA269	Murata SAFEK1G96K80F04	Murata SAFEK1G84FC0F04	Murata SAFEK942MFL0F04
US BOM2	1p5	na	10n	na	na	na	na	Matsushita ENFVZ7095	NDK NKG3138D	33nH	RFMD PA RF9250 ver 5.1	4k7	4k7	22k	10k	39k	1k	3n9	10n	33R	33R	10n	SAFEK897MFM0F04	Murata DA269	Murata SAFEK1G96K80F04	Murata SAFEK1G84FC0F04	Murata SAFEK881MFM0F04
US BOM2B	1p5	na	10n	na	na	na	2p7	FDK WB002G	Kyocera KT20a	33nH	RFMD PA RF9250 ver 5.1	4k7	4k7	22k	10k	39k	1k	3n9	10n	33R	33R	10n	SAFEK897MFM0F04	Murata DA269	Murata SAFEK1G96K80F04	Murata SAFEK1G84FC0F04	Murata SAFEK881MFM0F04



B	C2208	P2	C3033	P7	C7719	F2	J2423	H6	N	R2700	R4	X2002	U4		
B2200	O5	C2209	Q3	C3180	O8	C7720	F4	J2424	G7	N1470	L8	R2701	R4	X2060	C4
B2401	F4	C2210	O4	C6156	K3	C7721	F4	J2425	G7	N2150	K5	R2800	O6	X2400	M4
B2402	T6	C2212	Q2	C6158	J3	C7800	D4	J2427	B4	N2600	I2	R2901	M2	X2700	Q5
C	C2213	O5	C6159	L4	C7801	D3	J2428	I5	N6156	K3	R2902	O8	Z		
C1470	K6	C2214	O6	C6162	J3	C7802	D3	J2429	S6	N6158	K3	R2903	N2	Z2400	N6
C1471	K6	C2215	P4	C6163	L3	C7803	E4	J2430	S6	N7500	E6	R3000	P7	Z2401	M8
C1472	K6	C2216	P2	C6164	K4	C7804	E4	J2431	H8	N7700	G3	R3180	P8	Z7700	F7
C1473	J6	C2217	O2	C6165	L3	C7805	E6	J2601	H2	R	R6156	K4	Z7800	E3	
C1474	J7	C2218	P4	C6167	K3	C7806	E6	J2602	I2	R1470	K6	R6159	J3	Z7801	D3
C1475	K8	C2219	R4	C6170	K3	C7807	E5	J2800	N2	R1471	J7	R6160	J3	Z7802	E5
C1476	K6	C2220	N6	C6173	L2	C7808	E5	J2801	N2	R1472	J7	R6163	J3	Z7803	E5
C1477	L7	C2221	N2	C6176	K2	D	J2802	M6	R1473	K8	R6166	L3			
C1478	K6	C2222	M3	C6178	K2	D1470	K7	J2803	O6	R1474	K6	R6169	K4		
C1479	L8	C2223	N3	C6179	K2	D2200	O3	J2804	M6	R1475	K6	R6180	L3		
C1480	L8	C2224	M3	C6180	L3	D2800	N7	J2805	P7	R1476	L7	R6181	L3		
C1481	L8	C2225	M2	C6182	L3	D3000	Q7	J2806	O2	R1477	K8	R6182	P3		
C1482	L7	C2226	N3	C6184	Q3	F	J2807	O6	R1478	L8	R6183	Q4			
C1483	L7	C2227	N4	C6185	Q4	F2000	T5	J2808	O6	R2000	T6	R7500	C5		
C2001	M5	C2228	N5	C7177	H2	G	J2809	O6	R2001	O6	R7501	B6			
C2002	J2	C2229	N4	C7500	C5	G2400	I5	J2810	O6	R2002	R2	R7502	B6		
C2003	J2	C2230	N4	C7501	B5	G7500	C5	J2811	P6	R2003	R2	R7503	C6		
C2004	J3	C2231	M4	C7502	B6	G7501	D8	J2812	P6	R2004	R3	R7504	E7		
C2005	P6	C2232	M3	C7503	B6	J	J2813	M7	R2005	R2	R7505	F7			
C2006	T5	C2233	M4	C7504	C6	J1000	M8	J2814	R7	R2006	T5	R7506	E7		
C2007	O4	C2234	M3	C7505	E8	J1001	M8	J2815	P7	R2007	T5	R7507	E8		
C2008	T5	C2235	M4	C7506	F8	J1002	M8	J3180	I3	R2008	T5	R7508	E8		
C2009	Q2	C2236	M4	C7507	E8	J1003	N8	J3181	P7	R2009	T4	R7509	F8		
C2010	M6	C2237	M4	C7508	F8	J1004	N2	J3182	P8	R2010	T4	R7510	F8		
C2011	R2	C2238	M3	C7509	F8	J1005	N2	J3183	P8	R2011	T4	R7511	D5		
C2012	T5	C2239	M5	C7510	E8	J1006	M8	J3184	I4	R2151	C4	R7512	D6		
C2013	T5	C2240	P3	C7511	E7	J1470	M8	L	J2815	J	R7513	C8			
C2014	T4	C2241	O4	C7512	E8	J1471	M8	L2000	T5	R2153	Q4	R7514	F6		
C2015	T4	C2242	G2	C7513	E8	J1472	L7	L2001	T4	R2154	Q4	R7515	C7		
C2016	T4	C2270	O2	C7516	D7	J1473	L7	L2002	T4	R2155	J6	R7516	D8		
C2017	T4	C2271	P2	C7517	D6	J1474	J8	L2003	T5	R2156	R4	R7517	F8		
C2018	T5	C2272	N2	C7518	D6	J2000	I3	L2004	T5	R2158	Q4	R7700	N2		
C2019	T4	C2273	O4	C7519	D6	J2001	I4	L2005	T6	R2159	Q4	R7701	G2		
C2020	T4	C2400	P4	C7520	E6	J2002	I4	L2006	L2	R2160	Q3	R7702	G4		
C2021	T4	C2401	P4	C7521	D6	J2003	I3	L2150	C4	R2162	Q4	R7704	G2		
C2150	R4	C2402	C4	C7522	D7	J2004	I4	L2153	Q3	R2163	J6	R7705	G4		
C2151	K6	C2403	Q3	C7523	D5	J2005	T8	L2154	H5	R2164	J5	R7710	H2		
C2152	R3	C2404	Q2	C7524	D5	J2006	T7	L2155	G5	R2171	Q4	R7712	G3		
C2153	K5	C2405	Q2	C7525	D7	J2007	G6	L2200	M5	R2172	Q4	R7713	G3		
C2154	Q3	C2406	C4	C7526	C8	J2008	S3	L2404	Q2	R2173	Q4	R7715	G3		
C2155	K6	C2407	K5	C7527	C7	J2009	S3	L2405	K5	R2174	P4	R7716	G3		
C2156	K6	C2408	J4	C7528	F6	J2010	S2	L2406	K4	R2175	P3	R7800	D4		
C2157	P3	C2409	L4	C7529	D7	J2100	G5	L6156	K3	R2176	P3	R7801	E4		
C2159	Q4	C2410	K4	C7530	D7	J2101	G5	L6176	K2	R2200	N5	R7802	E4		
C2164	P2	C2411	L6	C7531	F6	J2115	R7	L7500	D7	R2201	P4	S			
C2170	Q4	C2600	F2	C7532	F6	J2116	P7	L7501	E7	R2202	Q3	S2300	G9		
C2171	Q4	C2601	I2	C7533	F8	J2117	R8	L7502	E7	R2203	Q3	S2301	I9		
C2173	P4	C2602	I2	C7701	G2	J2118	R7	L7503	E7	R2204	Q3	S2419	B4		
C2175	R3	C2603	J2	C7702	F2	J2400	I5	L7504	E7	R2205	Q2	T			
C2176	R4	C2700	Q4	C7703	F3	J2401	J5	L7700	H4	R2270	O2	T7500	C6		
C2177	H5	C2701	R5	C7704	F3	J2402	I6	L7701	G2	R2271	O2	T7700	F6		
C2178	G5	C2702	R6	C7705	H3	J2403	J6	L7702	F7	R2272	N2	T7800	F5		
C2179	Q3	C2703	R6	C7706	H4	J2404	I6	L7704	F2	R2273	P2	V			
C2180	H5	C2800	O6	C7707	F2	J2405	J6	L7705	F4	R2274	P2	V2000	O6		
C2181	P3	C2880	N6	C7708	G3	J2406	I7	L7710	H2	R2400	L6	V2402	L5		
C2184	R4	C2881	N6	C7709	G4	J2407	J7	L7800	D3	R2401	L5	V2420	L5		
C2187	Q4	C2882	O8	C7710	F4	J2408	I7	L7801	E4	R2420	L7	V7800	D4		
C2200	N5	C2883	N8	C7711	G2	J2409	J7	L7802	E6	R2421	L7	X			
C2201	N4	C2884	O6	C7712	G3	J2410	I8	L7803	E6	R2422	L7	X1001	O8		
C2202	P3	C2885	N8	C7713	E7	J2411	J8	L7804	E6	R2423	C4	X1002	O2		
C2203	Q2	C2900	N2	C7714	E6	J2418	H8	L7805	E6	R2424	J5	X1003	R8		
C2204	O5	C2901	N2	C7715	E6	J2419	H7	L7806	F6	R2425	J5	X1004	R2		
C2205	O5	C2902	O8	C7716	G3	J2420	H6	L7807	E6	R2426	M5	X1470	H7		
C2206	N5	C3030	R7	C7717	F4	J2421	H6	M	R2428	M5	X2000	I3			
C2207	M4	C3031	R6	C7718	F2	J2422	H7	M2400	T3	R2600	E2	X2001	U7		



L	
L2501	J3
L2502	J6
L2503	D2
L2504	D6
R	
R2501	J3
R2502	J6
R2503	D2
R2504	D6
R2505	D7
R2506	D1
V	
V2501	J3
V2502	J6
V2503	D3
V2504	D6

