

SHEET TITLE

01	COVER SHEET
02	BLOCK DIAGRAM
03	BOM & PCB MODIFY HISTORY
04	P4 LGA775 A
05	P4 LGA775 B
06	P4 LGA775 C
07	P4 LGA775 D,E,F,G
08	GMCH-LAKEPORT HOST
09	GMCH-LAKEPORT DDRII
10	GMCH-LAKEPORT PCI E, DMI
11	GMCH-LAKEPORT INT VGA
12	GMCH-LAKEPORT GND
13	GMCH-LAKEPORT PWR
14	DDRII CHANNEL A 1
15	DDRII CHANNEL B 2
16	DDRII TERMINATION
17	PCI EXPRESS*16 SLOT
18	ICH7 PCI, USB, DMI, LAN
19	ICH7 IDE, GPIO, SATA, CTRL
20	ICH7 VCC, GND
21	GB/CK410M-OC CLOCK.
22	PCI SLOT 1,2,3
23	IDE/FLOPPY
24	ITE 8718 GBIX
25	COM LPT
26	BIOS, CI, HWM, KB/MS
27	AZALIA ALC888

SHEET TITLE

28	REAR AUDIO JACK
29	DISCRETE POWER
30	VCORE PWM ISL6312
31	ATX, OTHERS POWER
32	REALTEK RTL8110SC
33	FRONT PANEL

Gigabyte Technology

Title		
Cover Sheet		
Size	Document Number	Rev
Custom	945GCM-S2	3.0
Date:	Wednesday, January 03, 2007	Sheet 1 of 33

BLOCK DIAGRAM

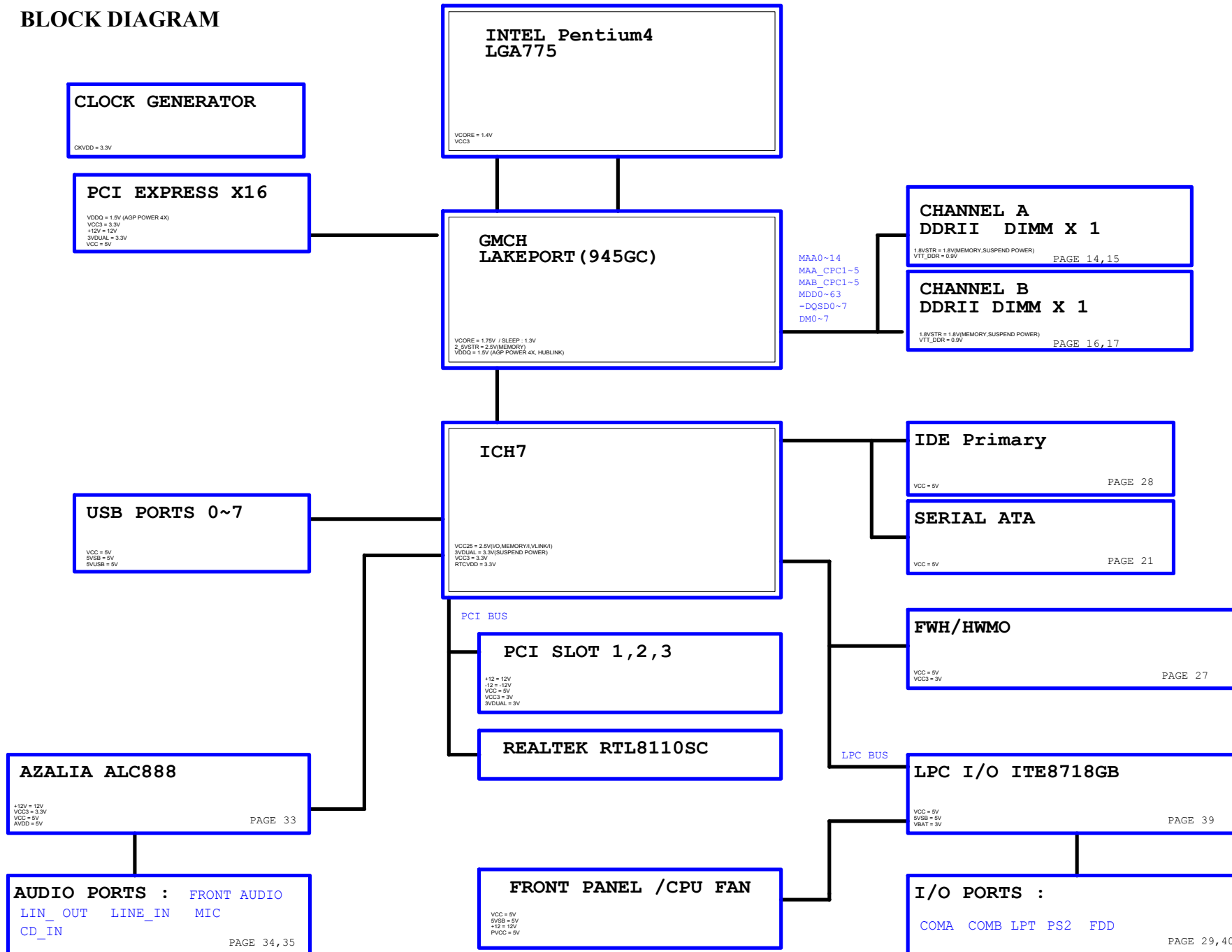

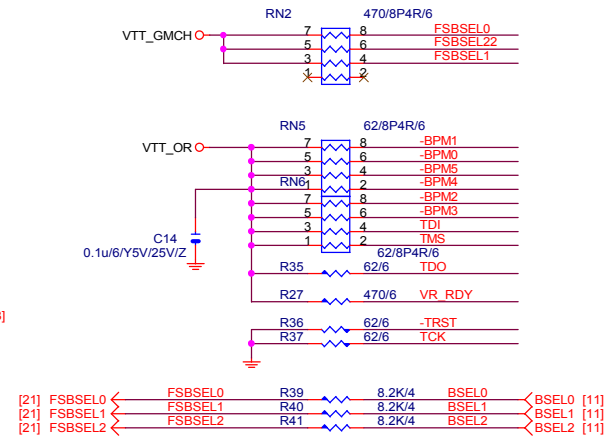
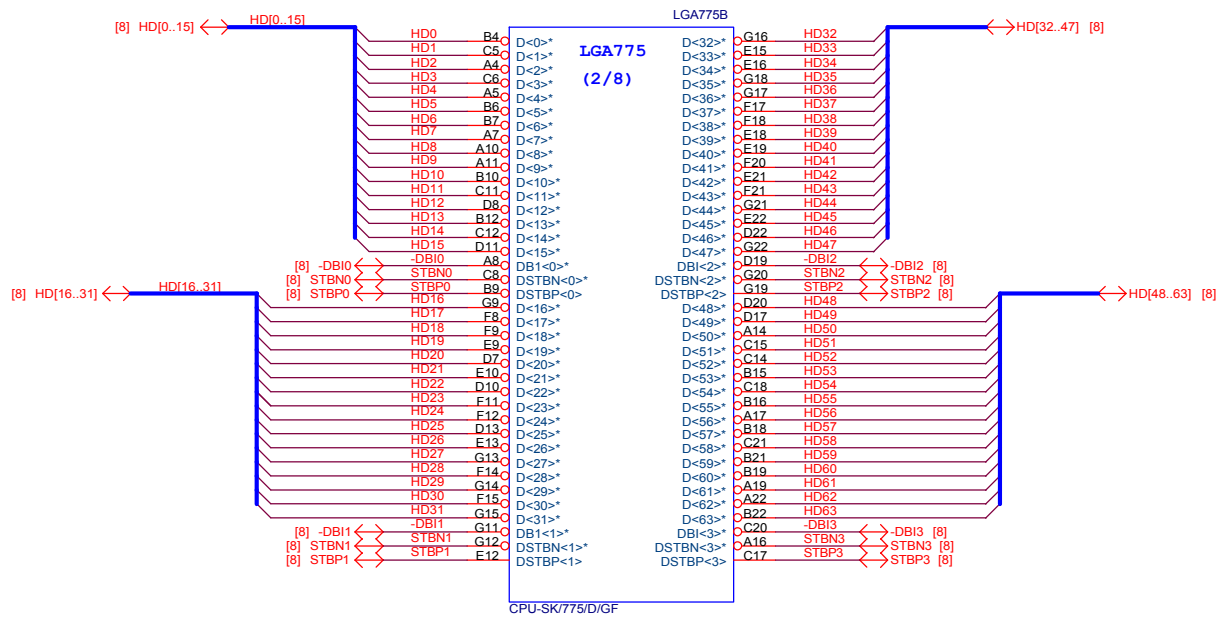

CPU

NA	FSB	FSA	Clock
FSBSEL3 = 1	FSBSEL1 = 0	FSBSEL0 = 1	100MHz
FSBSEL3 = 0	FSBSEL1 = 0	FSBSEL0 = 1	133MHz
FSBSEL3 = 0	FSBSEL1 = 1	FSBSEL0 = 1	166MHz
FSBSEL3 = 0	FSBSEL1 = 1	FSBSEL0 = 0	200MHz
FSBSEL3 = 0	FSBSEL1 = 0	FSBSEL0 = 0	266MHz

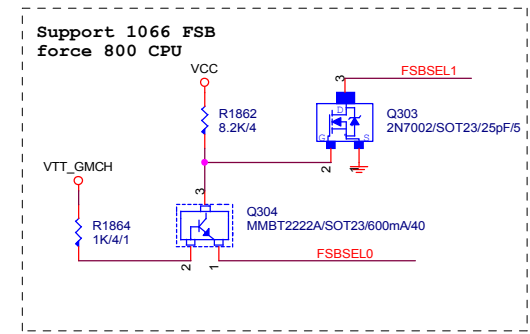
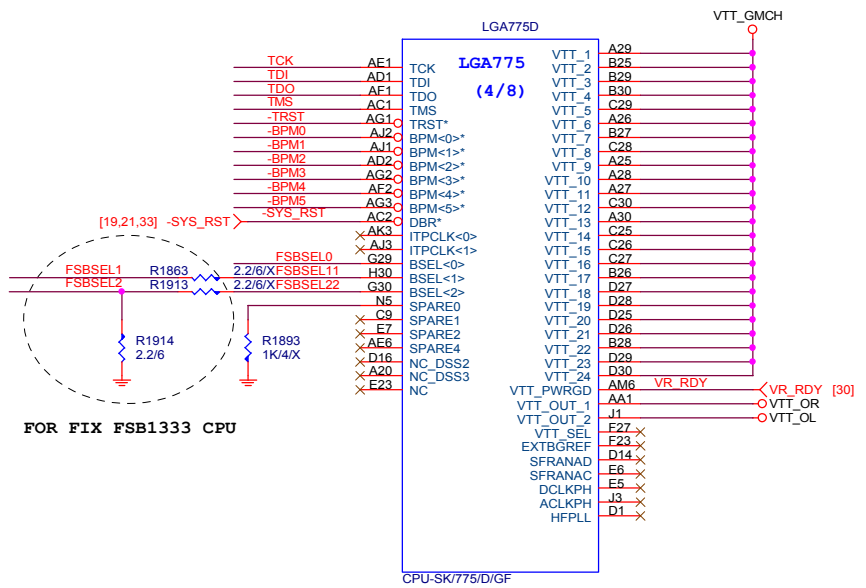

Gigabyte Technology

Title		P4_LGA775-B,D	
Size	Document Number	945GCM-S2	
Custom			Rev 3.0
Date:	Wednesday, January 03, 2007	Sheet	5 of 33

Note:
VCCA & VCOREPLL
define doesn't same as
old P4 design kit

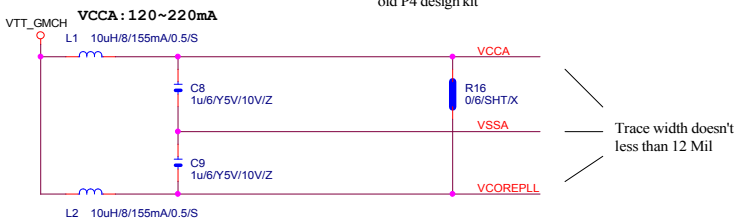

Trace width doesn't
less than 12 Mil

As close as possible to
CPU socket

VCOREPLL : 100mA

CPU

FSA	FSB	NA	Clock	
FSBSEL0	FSBSEL1	FSBSEL3		
1	0	1	100MHz	X
1	0	0	133MHz	
1	1	0	166MHz	RATIO
0	1	0	200MHz	2.66/3.33
0	0	0	266MHz	2.00/2.5

945 Design Guide rev1.5 spec.
VCCA=120~220mA
公板為125mA

10LI2-12100A-13=INDUCTOR 10uH 300mA TAI-TECH
10LI2-12100A-02=INDUCTOR 10uH 155mA TAIYO
10LI2-12100A-01=INDUCTOR 10uH 120mA TDK

限用兩種

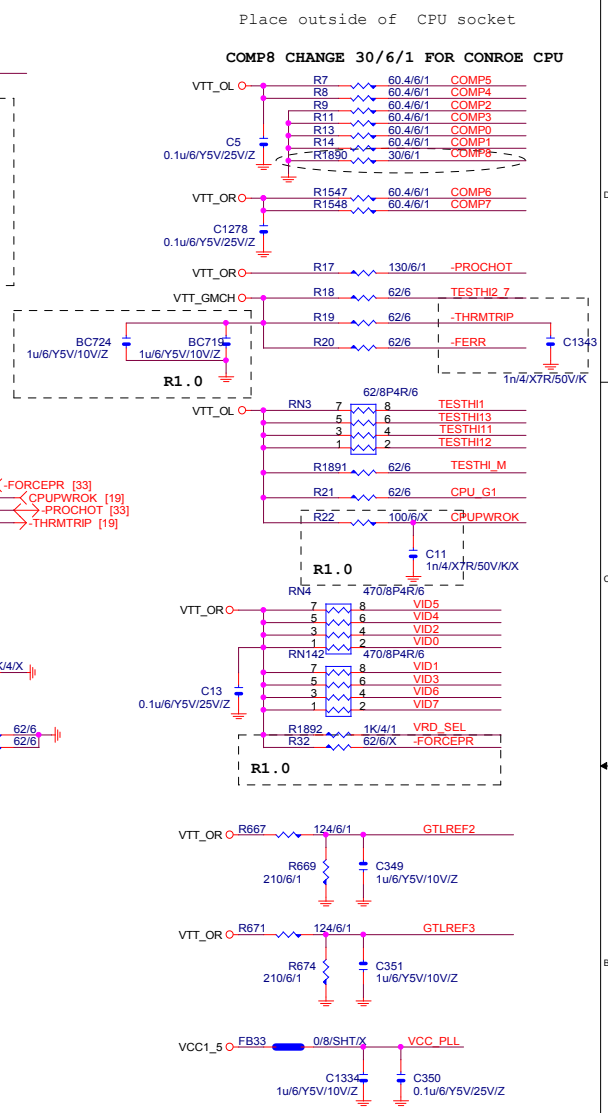
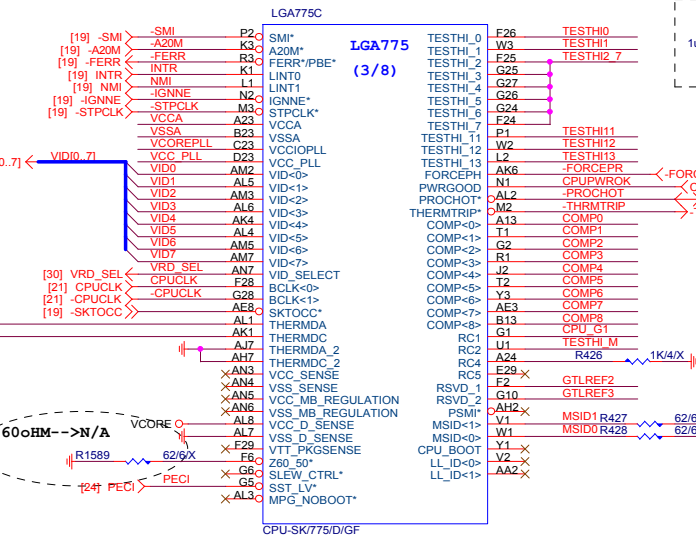
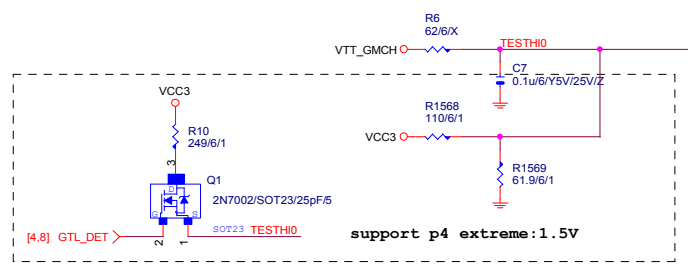

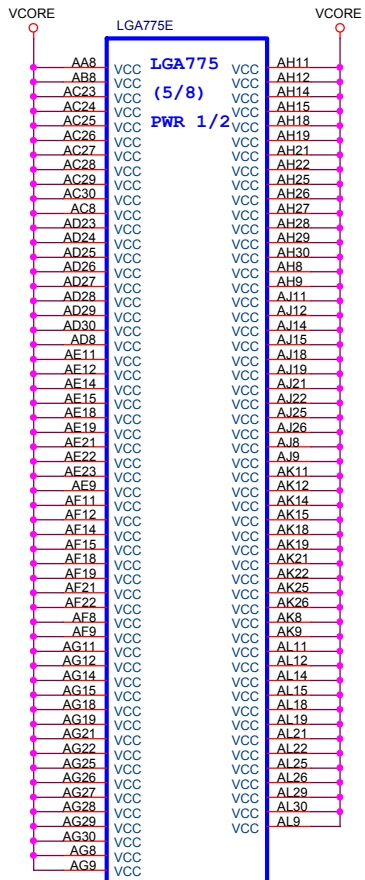

CPU-SK/775/D/GF

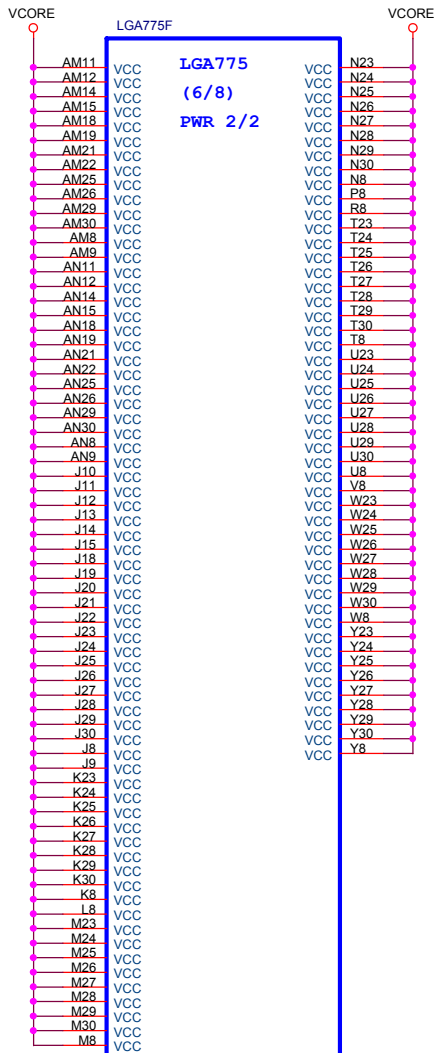

CPU-SK/775/D/GF

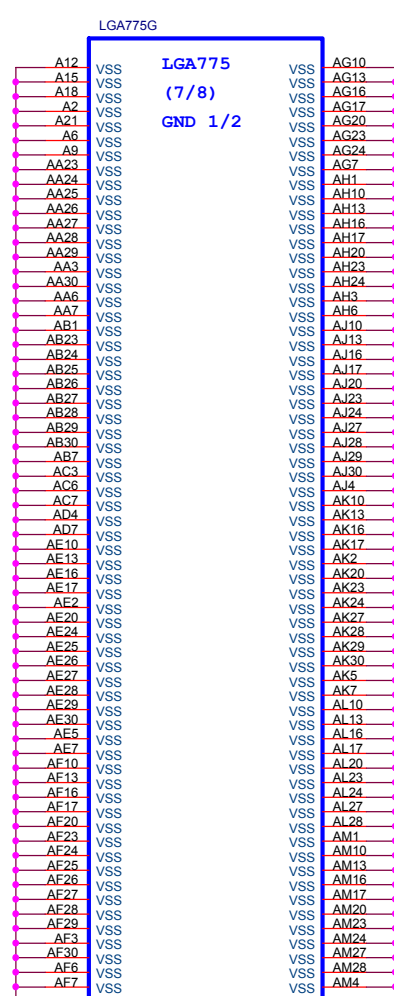

CPU-SK/775/D/GF

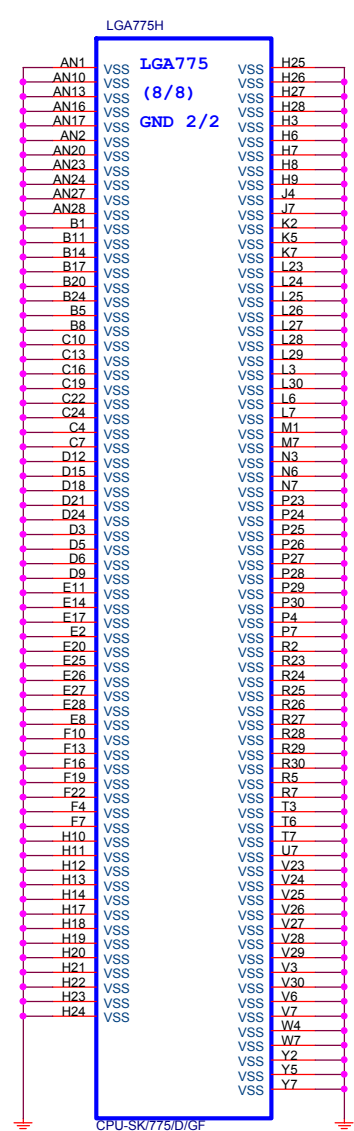

CPU-SK/775/D/GF

Gigabyte Technology

Title			P4_LGA775-E,F,G,H		
Size B	Document Number	945GCM-S2		Rev	3.0
Date:	Wednesday, January 03, 2007	Sheet	7	of	33

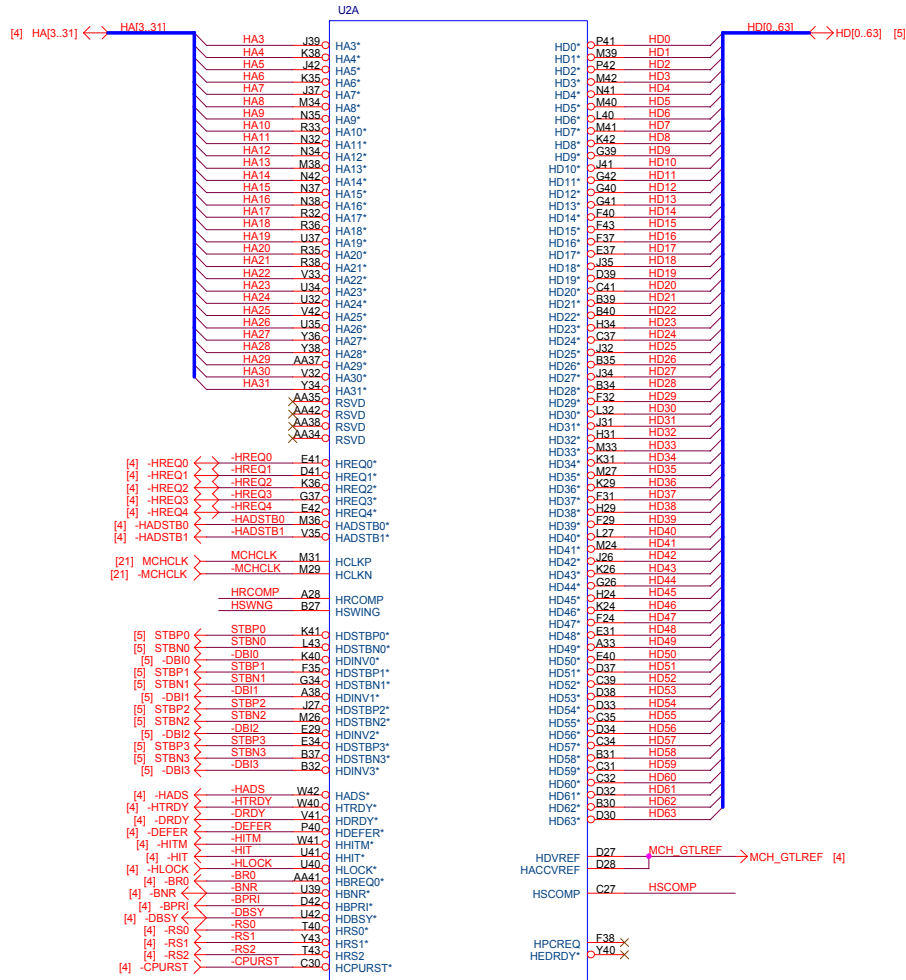

945GC/BGA1202[10HB1-033000-71R]

Pb-Free

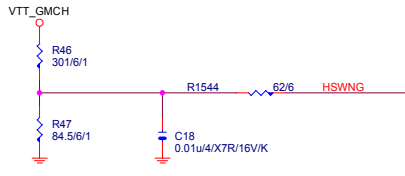
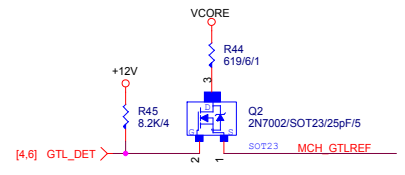
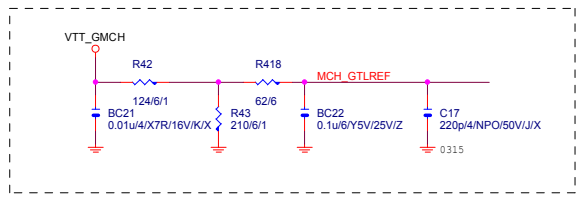

Gigabyte Technology		
Title GMCH-HOST		
Size Custom	Document Number 945GCM-S2	Rev 3.0
Date: Wednesday, January 03, 2007	Sheet 8	of 33

U2F

U2G

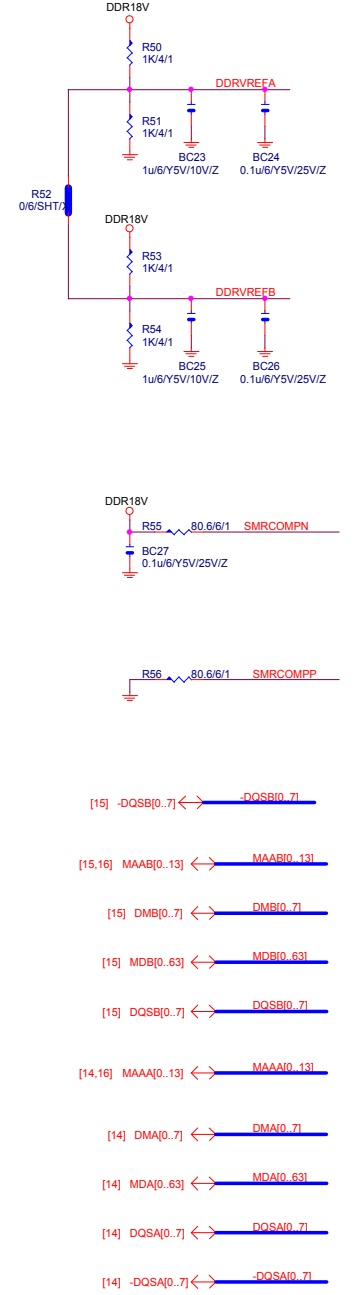
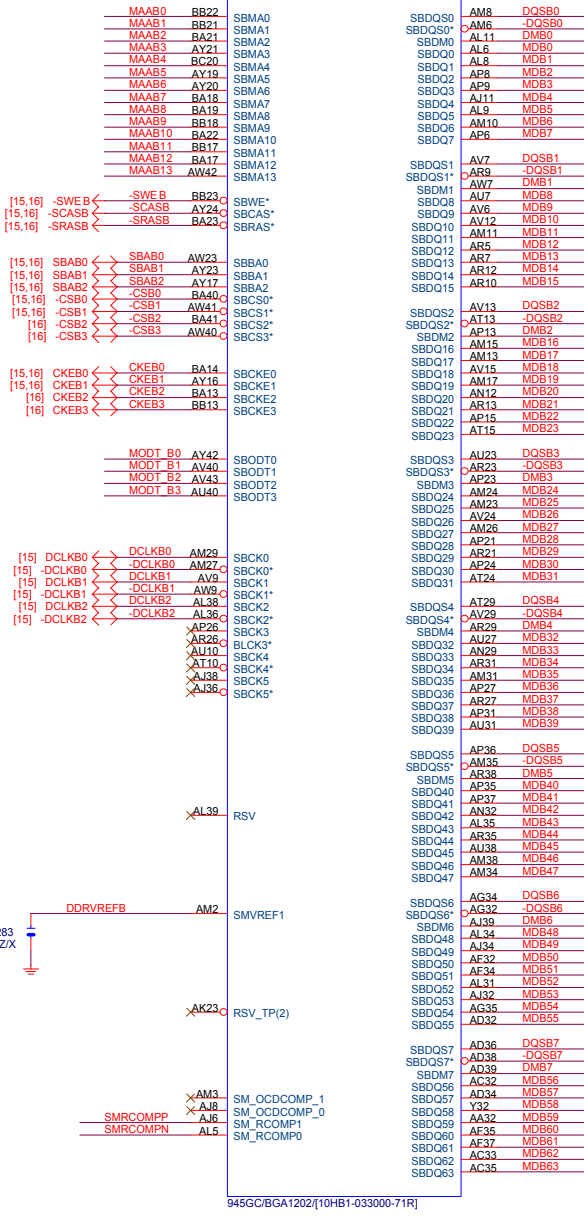

NB_HEATSIN

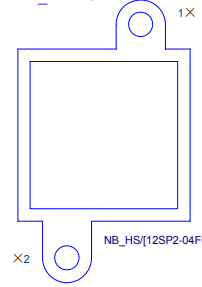

NB_HS[12SP2-04F003-C1R_12SP2-04F003-C2R_12SP2-04F003-C3R]

945GC/BGA1202[10HB1-033000-71R]

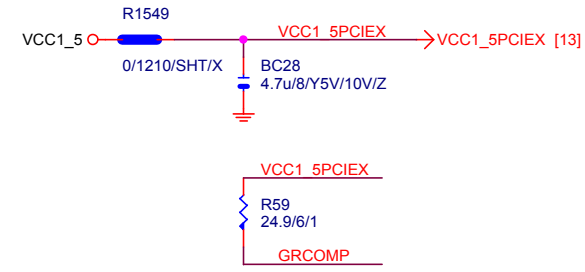
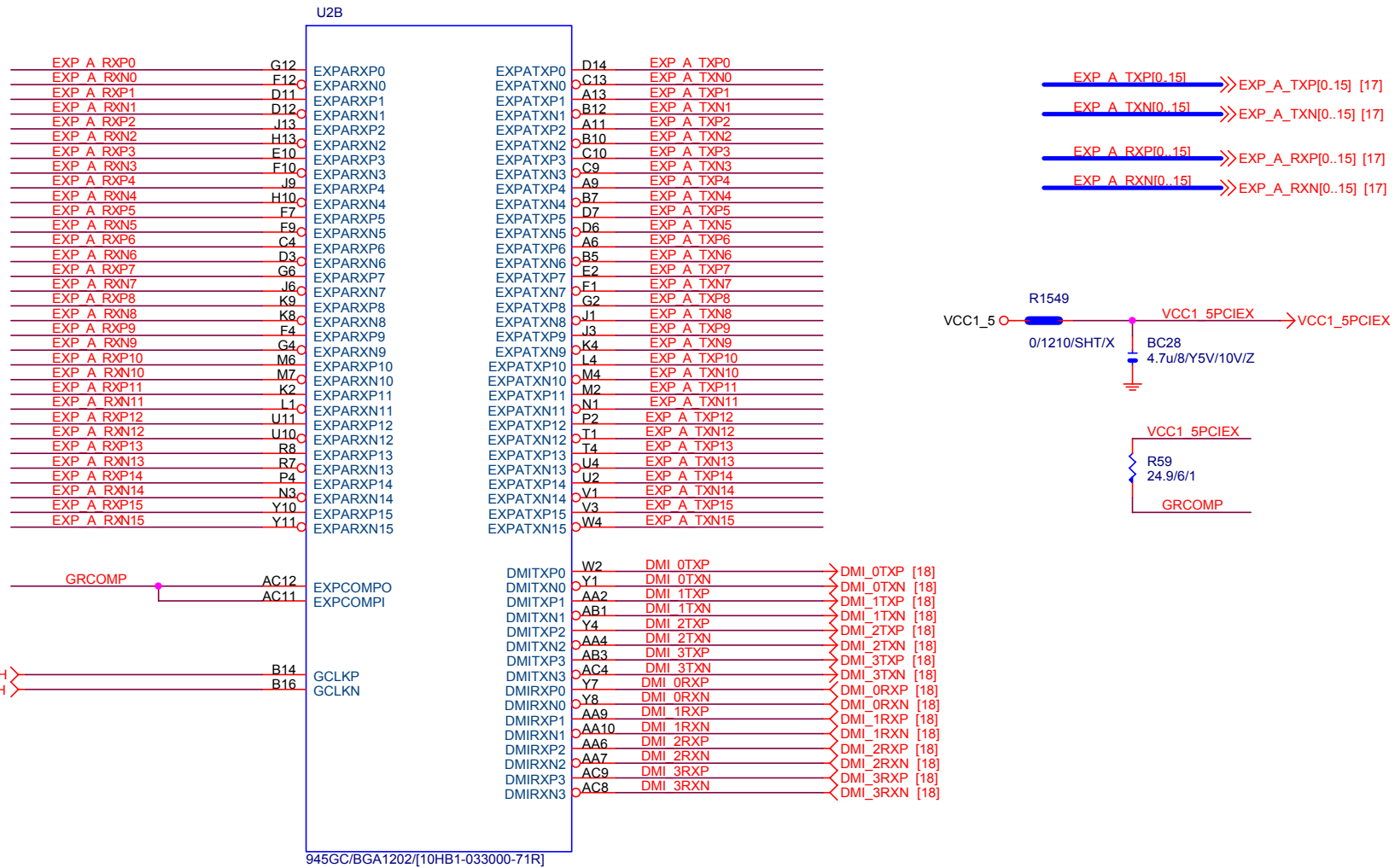

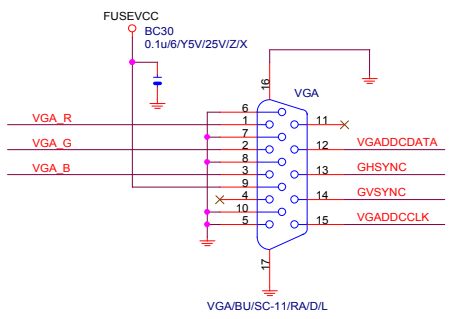
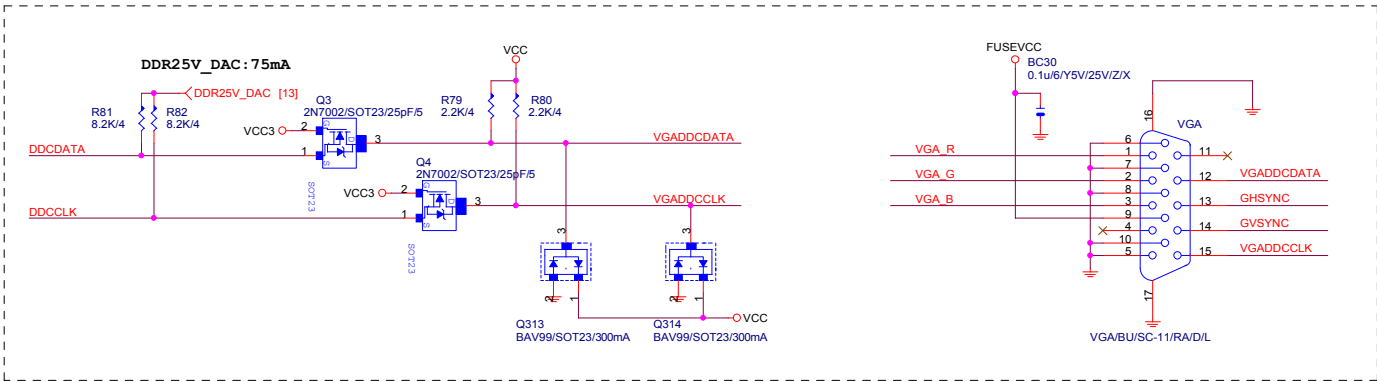
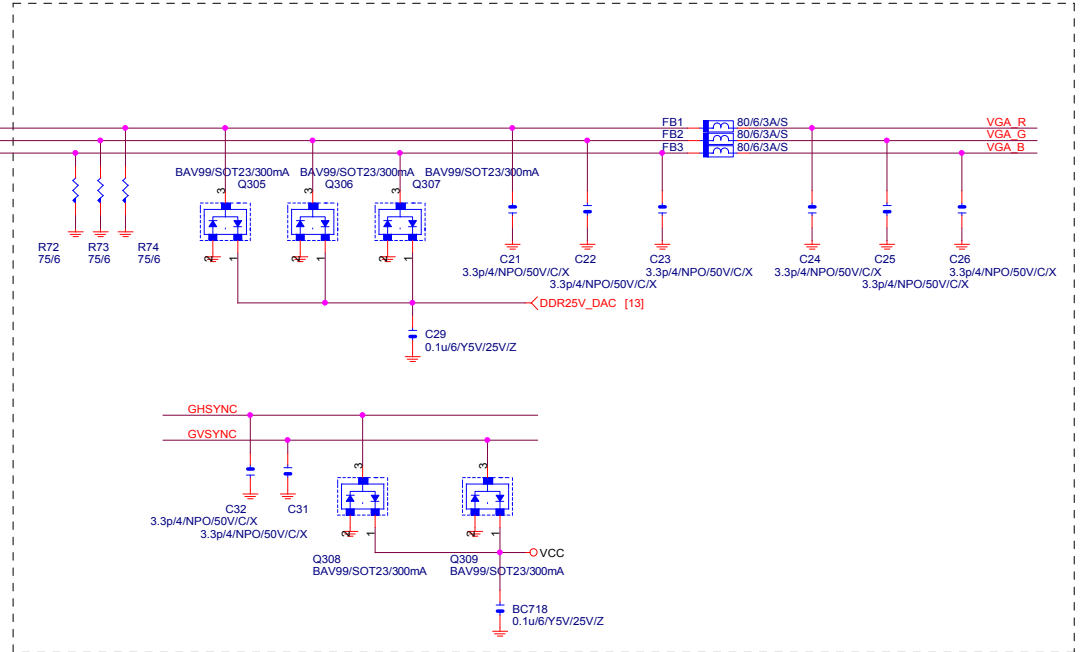
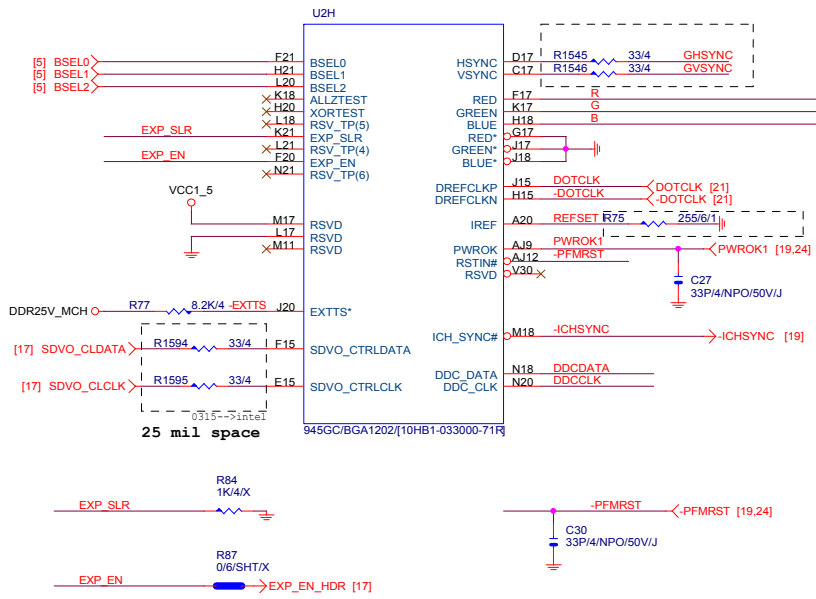

U2C

A4	VSS	N2
A16	VSS	N6
A22	VSS	N8
A26	VSS	N13
A31	VSS	N15
A35	VSS	N24
B4	VSS	N26
B6	VSS	N27
B9	VSS	N29
B11	VSS	N31
B13	VSS	N33
B21	VSS	N36
B22	VSS	N39
B28	VSS	N43
B33	VSS	P3
B38	VSS	P14
C3	VSS	P15
C5	VSS	P24
C7	VSS	P26
C12	VSS	P27
C14	VSS	P29
C22	VSS	P30
C40	VSS	R6
D2	VSS	R9
D5	VSS	R12
D10	VSS	R14
D16	VSS	R30
D20	VSS	R31
D21	VSS	R34
E3	VSS	R37
E4	VSS	R39
E7	VSS	T2
E9	VSS	T7
F12	VSS	T12
F13	VSS	U3
F17	VSS	U5
F18	VSS	U9
F20	VSS	U12
F21	VSS	U14
F32	VSS	U31
F2	VSS	U33
F8	VSS	U38
F13	VSS	V2
F18	VSS	V8
F26	VSS	V11
F34	VSS	V12
F42	VSS	V14
G3	VSS	V34
G5	VSS	V36
G7	VSS	V37
G9	VSS	V38
G10	VSS	V39
G13	VSS	V43
G15	VSS	W3
G18	VSS	Y2
G20	VSS	Y5
G21	VSS	Y6
G24	VSS	Y9
G27	VSS	Y12
G29	VSS	Y14
G31	VSS	Y31
G32	VSS	Y35
G35	VSS	Y39
G38	VSS	Y42
H12	VSS	Y43
H17	VSS	Y45
H26	VSS	Y37
H27	VSS	Y39
H32	VSS	Y42
J2	VSS	AA3
J5	VSS	AA8
J7	VSS	AA11
J10	VSS	AA12
J12	VSS	AA14
J21	VSS	AA21
J24	VSS	AA23
J29	VSS	AA31
J38	VSS	AA33
J43	VSS	AA36
K3	VSS	AB2
K5	VSS	AB43
K6	VSS	AC2
K7	VSS	AC3
K10	VSS	AC7
K12	VSS	AC10
K13	VSS	AC14
K15	VSS	AC21
K20	VSS	AC23
K27	VSS	AC31
K32	VSS	AC36
K34	VSS	AC37
K37	VSS	AC39
K39	VSS	AC38
L2	VSS	AC39
L12	VSS	
L13	VSS	
L24	VSS	
L26	VSS	
L29	VSS	
L31	VSS	
L42	VSS	
M3	VSS	
M5	VSS	
M8	VSS	
M9	VSS	
M10	VSS	
M13	VSS	
M20	VSS	
M21	VSS	
M35	VSS	
M37	VSS	

945GC/BGA1202[10HB1-033000-71R]

U2E

AD7	VSS	AD7
AD9	VSS	AD9
AD11	VSS	AD11
AD13	VSS	AD13
AD33	VSS	AD33
N24	VSS	N24
AD37	VSS	AD37
AD42	VSS	AD42
N29	VSS	N29
AF2	VSS	AF2
N33	VSS	N33
AF5	VSS	AF5
N39	VSS	N39
AF36	VSS	AF36
P3	VSS	P3
P14	VSS	P14
P15	VSS	P15
AG31	VSS	AG31
AG33	VSS	AG33
AG36	VSS	AG36
AG37	VSS	AG37
AG38	VSS	AG38
AG39	VSS	AG39
AH42	VSS	AH42
R12	VSS	R12
A10	VSS	A10
A30	VSS	A30
A31	VSS	A31
A33	VSS	A33
A35	VSS	A35
A37	VSS	A37
AK24	VSS	AK24
AK26	VSS	AK26
AK29	VSS	AK29
AK30	VSS	AK30
AL1	VSS	AL1
AL3	VSS	AL3
AL7	VSS	AL7
AL10	VSS	AL10
AL12	VSS	AL12
AL13	VSS	AL13
AL15	VSS	AL15
AL18	VSS	AL18
AL21	VSS	AL21
AL23	VSS	AL23
AL24	VSS	AL24
AL27	VSS	AL27
AL32	VSS	AL32
AL33	VSS	AL33
V38	VSS	V38
AL43	VSS	AL43
AM5	VSS	AM5
AM7	VSS	AM7
Y2	VSS	Y2
AM3	VSS	AM3
AM33	VSS	AM33
Y6	VSS	Y6
AM36	VSS	AM36
Y9	VSS	Y9
AM39	VSS	AM39
Y12	VSS	Y12
AN2	VSS	AN2
Y31	VSS	Y31
Y35	VSS	Y35
AN13	VSS	AN13
Y37	VSS	Y37
AN15	VSS	AN15
AN17	VSS	AN17
AN18	VSS	AN18
AN20	VSS	AN20
AN21	VSS	AN21
AN23	VSS	AN23
AN24	VSS	AN24
AN26	VSS	AN26
AN27	VSS	AN27
AN31	VSS	AN31
AN42	VSS	AN42
AP5	VSS	AP5
AP7	VSS	AP7
AP10	VSS	AP10
AP12	VSS	AP12
AP29	VSS	AP29
AP34	VSS	AP34
AP38	VSS	AP38
AR1	VSS	AR1
AR6	VSS	AR6
AR15	VSS	AR15
AR20	VSS	AR20
AR24	VSS	AR24
AR32	VSS	AR32
AR37	VSS	AR37
AR39	VSS	AR39
AR43	VSS	AR43
AT12	VSS	AT12
AT17	VSS	AT17
AT18	VSS	AT18
AT21	VSS	AT21
AT23	VSS	AT23
AT26	VSS	AT26
AT27	VSS	AT27
AT31	VSS	AT31
AU6	VSS	AU6
AU9	VSS	AU9
AU12	VSS	AU12
AU13	VSS	AU13
AU15	VSS	AU15
AU17	VSS	AU17
AU20	VSS	AU20
AD18	VSS	AD18
AD20	VSS	AD20
AD22	VSS	AD22
AD24	VSS	AD24
AD27	VSS	AD27
AD29	VSS	AD29
AE19	VSS	AE19
AE21	VSS	AE21
AE23	VSS	AE23
AE25	VSS	AE25
AF18	VSS	AF18
AF20	VSS	AF20
AF22	VSS	AF22
AF24	VSS	AF24
AY1	VSS	AY1
BC4	VSS	BC4

945GC/BGA1202[10HB1-033000-71R]

VSS	AU21
VSS	AU24
VSS	AU26
VSS	AU29
VSS	AU32
VSS	AU34
VSS	AV2
VSS	AV10
VSS	AV17
VSS	AV37
VSS	AW10
VSS	BA4
VSS	BA42
VSS	BB3
VSS	BB6
VSS	BB11
VSS	BB14
VSS	BB19
VSS	BB34
VSS	BB39
VSS	BB41
VSS	BC9
VSS	A40
VSS	D1
VSS	D43
VSS	R26
VSS	R29
VSS	U29
VSS	V24
VSS	V26
VSS	V29
VSS	W21
VSS	W23
VSS	W25
VSS	Y20
VSS	Y22
VSS	Y24
VSS	Y26
VSS	Y29
VSS	AA27
VSS	AA29
VSS	AC19
VSS	AC26
VSS	AC29

NC	A42
NC	B2
NC	B3
NC	B4
NC	B42
NC	B43
NC	C2
NC	C42
NC	E35
NC	AV26
NC	AV27
NC	AV28
NC	AW26
NC	BA2
NC	BB1
NC	BB2
NC	BB43
NC	BC1
NC	BC2
NC	BC42
NC	BC43

RSVD	AK21
RSVD	AJ23
RSVD	AJ26
RSVD	AL20
RSVD	AL20
RSVD	AJ21
RSVD	AL26
RSVD	AK27
RSVD	AD30
RSVD	AC34
RSVD	Y30
RSVD	Y31
RSVD	AF31
RSVD	AD31
RSVD	U30
RSVD	V31
RSVD	AA30
RSVD	AC30
RSVD	AA3
RSVD	AG26
RSVD	AG28
RSVD	AG27
RSVD	AJ24
RSVD	AJ27
RSVD	AK40
RSVD	AW17
RSVD	AW19
RSVD	AY14
RSVD	BC16
RSVD	AJ25
RSVD	AG29

Gigabyte Technology

Title			GMCH-GND		
Size	Document Number	945GCM-S2		Rev	3.0
Date	Wednesday, January 03, 2007	Sheet	12	of	33

1. 425~1.575V

VCC1_5
P17
P18
P20
P21
AA2
AB21
AB22
AB23
AC22
AD14
AE6
AE7
AE8
AE9
AF10
AF11
AF12
AF13
AF14
AF30
AG2
AG3
AG4
AG5
AG6
AG7
AG8
AG9
AG10
AG11
AG12
AG13
AG14
AH1
AH2
AH4
AJ5
AJ13
AJ14
AK3
AK4
AK14
AK20
R15
R17
R18
R20
R21
R23
R24
U15
U17
U18
U19
U20
U21
U22
U23
U24
U25
U26
V15
V19
V18
V20
V21
V22
V23
V25
W27
W17
W18
W19
W20
W22
W24
W26
W27
Y15
Y17
Y18
Y19
Y21
Y23
Y26
Y27
AA15
AA17
AA18
AA19
AA20
AA24
AA26
AB17
AB18
AB19
AB20
AB24
AB25
AB26
AB27
AC15
AC17
AC18
AC20
AC24
AC26
AC27
AD15
AD17
AD19
AD21
AD23
AD25
AD26
AE17
AE18
AE20
AE22
AE24
AE26
AE27
AF15
AF17
AF19
AF21
AF23
AF25
AF26
AF27
AF29

1. 7~1.9V

BB16
AW15
BB42
BB43
BC18
BC22
BC26
BB20
VCCSM
AW24
BB36
BC31
BB38
BB33
BB28
BB24
AW29
AW31
AW31
AX41
AW42
AW23
AW18
BC40
AW38
AW43
AW20
AW21
AW13
AW21
C23
G23
P23
E23
D23
D24
D25
B25
B24
B23
B26
H23
J23
K23
L23
M23
E24
N23
F23
E27
E26
C25
C26
C26
C21
VCCA_MPLL
B20
VCCA_MPLL
C21
VCCA_HPLL
C19
VCCA_DPLLA
B18
DDR25V_DAC
C18
D19
VCCA_GPLL
B17
DDR25V_MCH
A18
VCC_EXP
AD12
AC5
AA5
V5
V5
V13
AE2
R13
N12
N10
R6
N7
N11
AE3
N9
AD10
AD1
AC8
AD8
AD2
AD4
AD5
AD6
Y13
N6
U8
AC13
AE4
U7
R10
R11
U6
V6
V7
V9
V10
AG15
AG17
AG18
AG19
AG20
AG21
AG22
AG23
AG24
A115
A117
A118
A120

1.14~1.26V

VTT
VTT
VTT
D25
B25
B24
B23
B26
H23
J23
K23
L23
M23
E24
N23
F23
E27
E26
C25
C26
C26

2.375~2.625V

VCCA_DAC=DDR25V_DAC=70mA (2.375~2.625V)

1.425~1.575V

VCCA_DPLL
VCCA_MPLL
VCCA_HPLL
VCCA_DPLLA
VCCA_DAC
VCCA_DAC
VCC2
VCCA_GPLL
VSSA_DAC
AA13
AD12
AC5
AA5
V5
V5
V13
AE2
R13
N12
N10
R6
N7
N11
AE3
N9
AD10
AD1
AC8
AD8
AD2
AD4
AD5
AD6
Y13
N6
U8
AC13
AE4
U7
R10
R11
U6
V6
V7
V9
V10
AG15
AG17
AG18
AG19
AG20
AG21
AG22
AG23
AG24
A115
A117
A118
A120

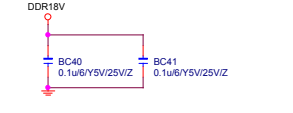
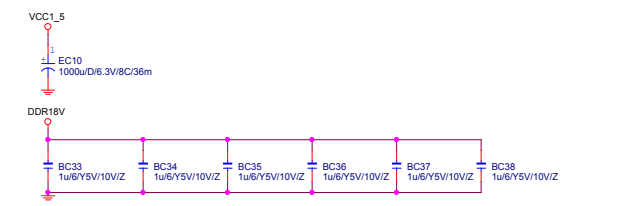
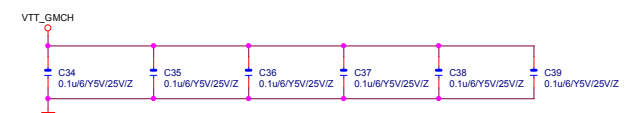
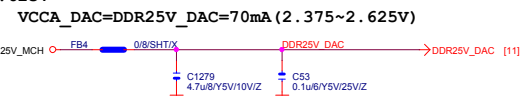
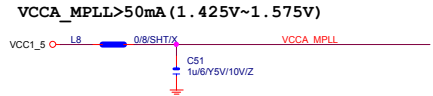
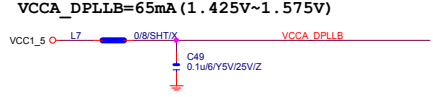
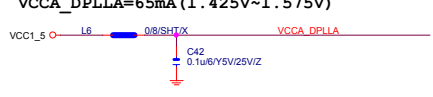
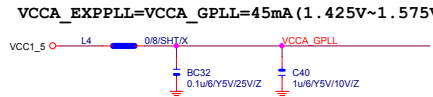

945 Design Guide rev1.5 spec.
 VCCA_EXPPLL=VCCA_GPLL=45mA (1.425V~1.575V)
 VCCA_HPLL>50mA 公板為200mA (1.425V~1.575V)
 VCCA_DPLLA=65mA (1.425V~1.575V)
 VCCA_DPLLB=65mA (1.425V~1.575V)
 VCCA_MPLL>50mA (1.425V~1.575V)
 VCCA_DAC=DDR25V_DAC=70mA (2.375~2.625V)

Gigabyte Technology		
File	GMCH-PWR	
Size Custon	Document Number 945GCM-S2	Rev 3.0
Date:	Wednesday, January 03, 2007	Sheet 13 of 33

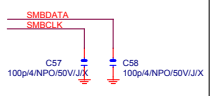
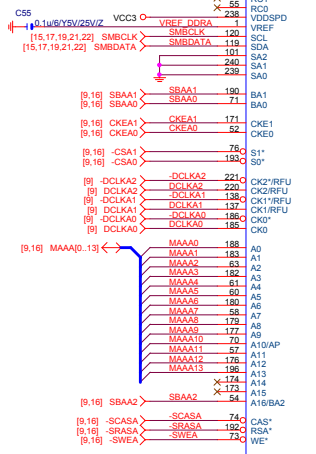
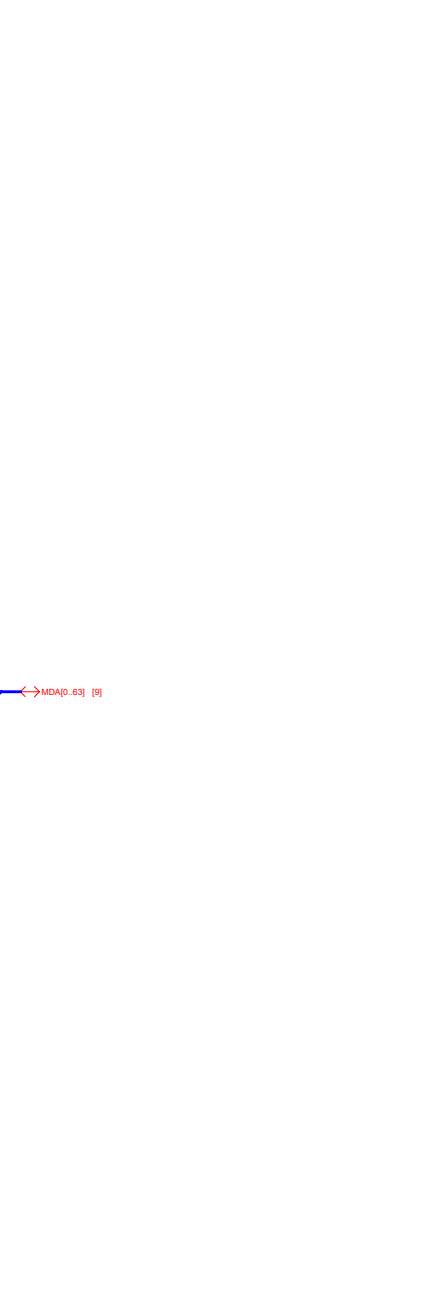
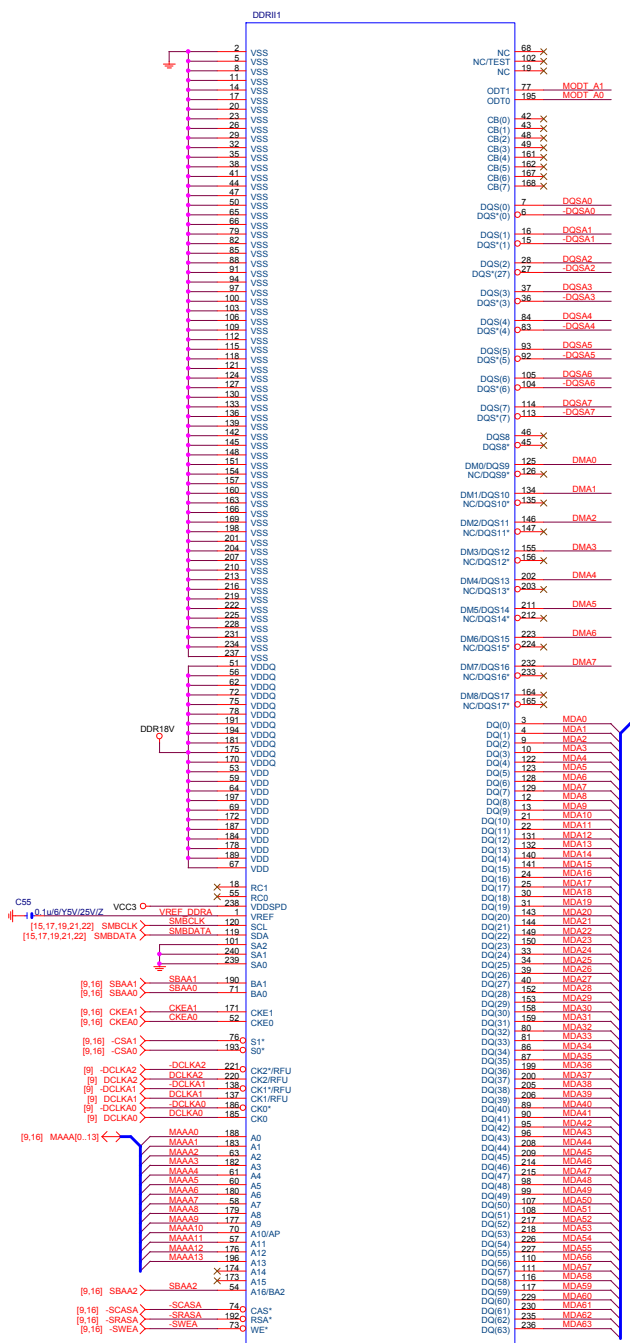

- MODT_A0_31 ↔ MODT_A0_31 [9,16]
- DDCSA0_71 ↔ DDCSA0_71 [9]
- DDCSA0_71 ↔ DDCSA0_71 [9]
- DMA0_71 ↔ DMA0_71 [9]

Gigabyte Technology		
DDRII CHANNEL A		
Title	945GCM-S2	
Size	Document Number	Rev.
Count	945GCM-S2	3.0
Date	Sheet	14 of 33

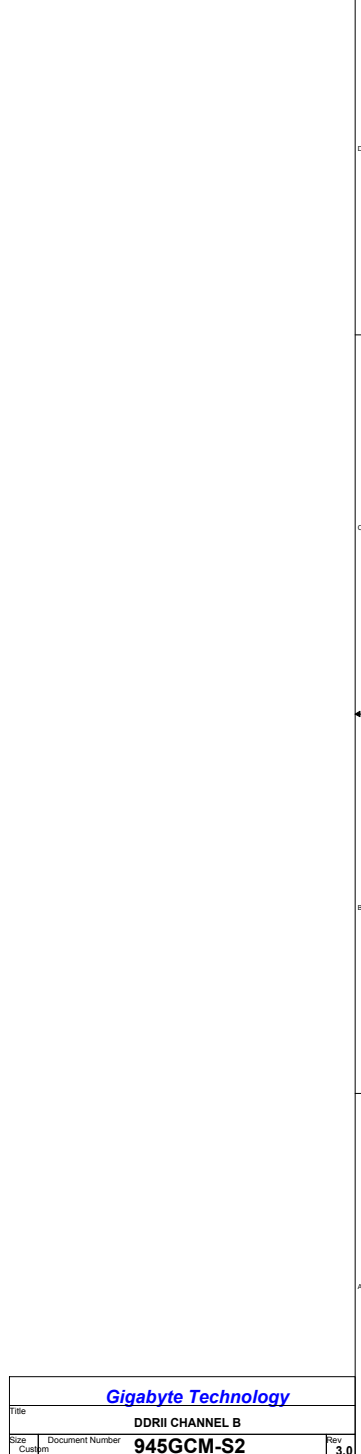
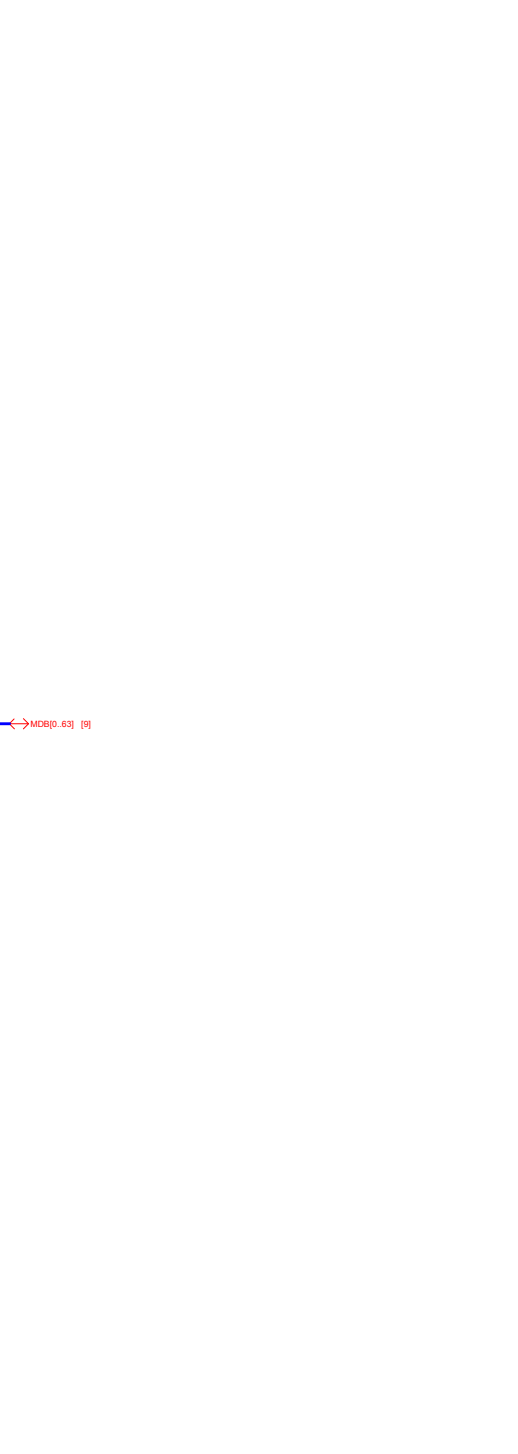
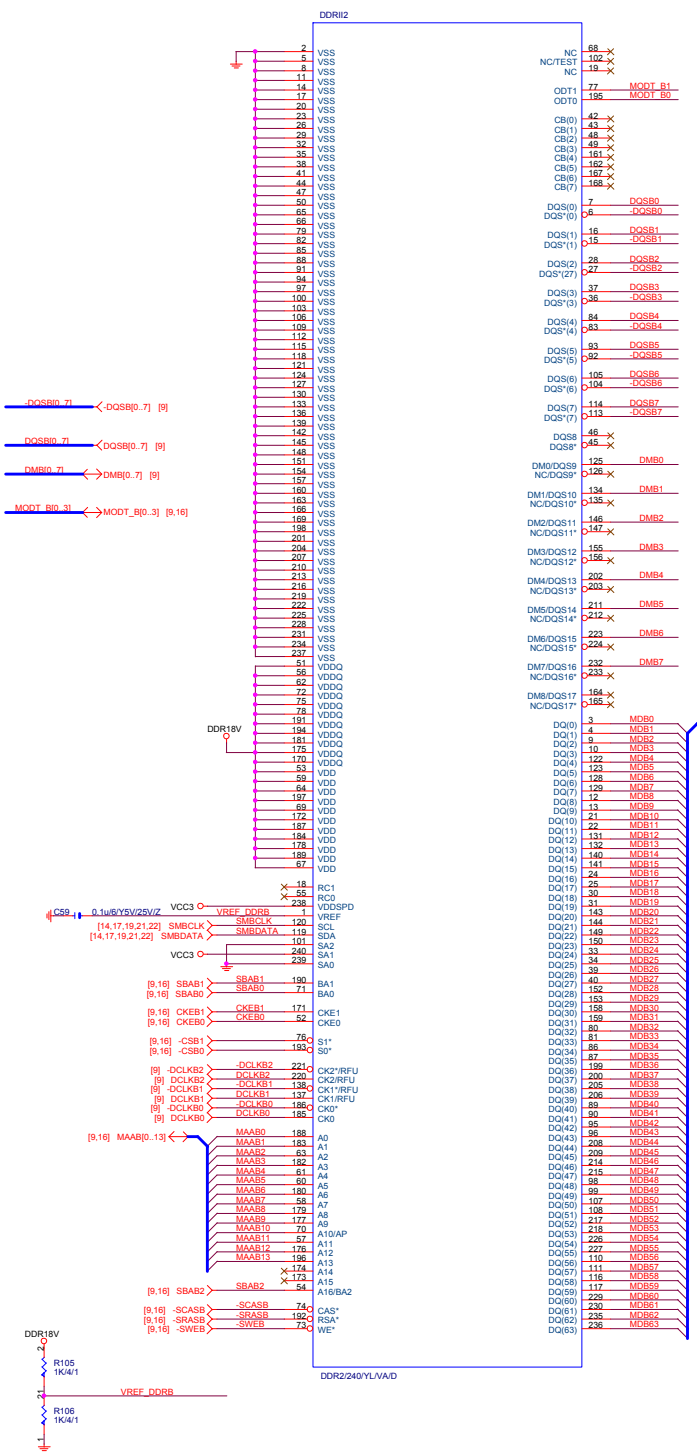

Gigabyte Technology		
Title DDR2 CHANNEL B		
Size Column	Document Number 945GCM-S2	Rev. 3.0
Date	Sheet 15 of 33	

DDR TERMINATION CHANNEL A

DDRVTT Decouple

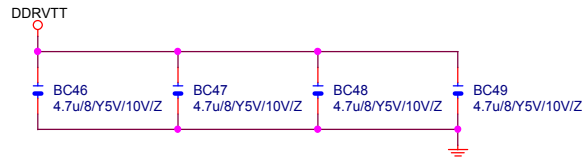
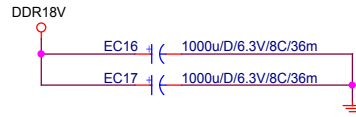
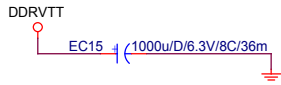

DDR18V Decouple

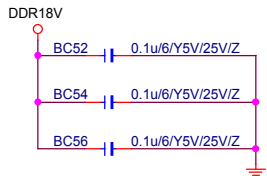

DDRVTT Decouple

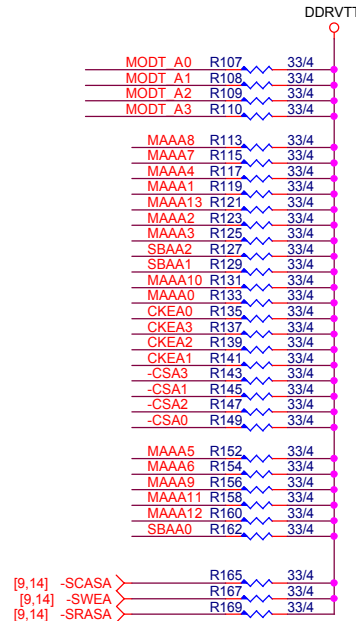
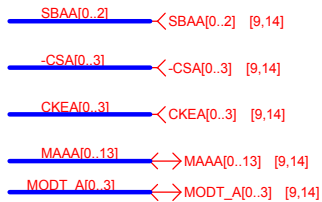
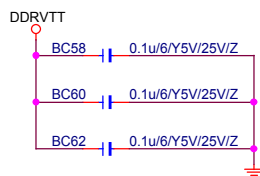

DDR TERMINATION CHANNEL B

DDR18V Decouple

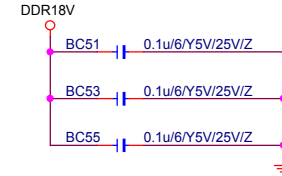

DDRVTT Decouple

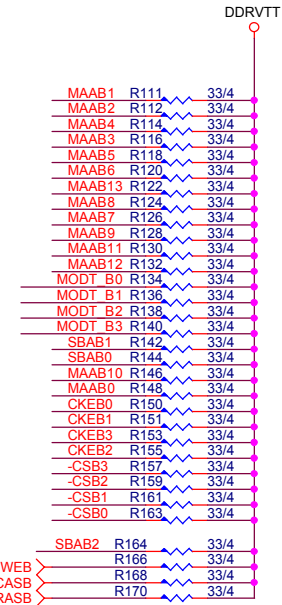
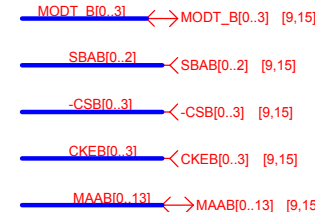
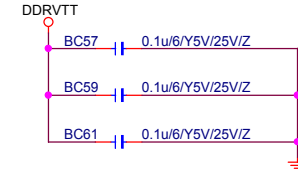

Gigabyte Technology

Title		
DDRII TERMINATOR		
Size Custom	Document Number	Rev
	945GCM-S2	3.0
Date:	Wednesday, January 03, 2007	Sheet 16 of 33

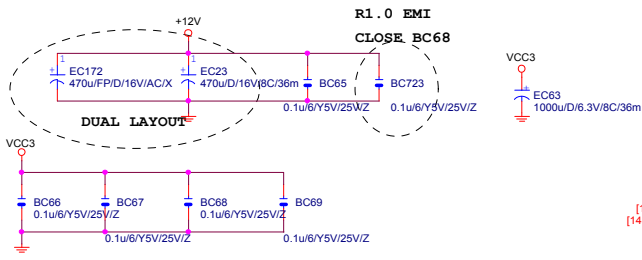

EXP_A_TXP0	C92	0.1u/4Y5V/16V/Z	EXP_A_TXP0C
EXP_A_TXN0	C93	0.1u/4Y5V/16V/Z	EXP_A_TXN0C
EXP_A_TXP1	C94	0.1u/4Y5V/16V/Z	EXP_A_TXP1C
EXP_A_TXN1	C95	0.1u/4Y5V/16V/Z	EXP_A_TXN1C
EXP_A_TXP2	C96	0.1u/4Y5V/16V/Z	EXP_A_TXP2C
EXP_A_TXN2	C97	0.1u/4Y5V/16V/Z	EXP_A_TXN2C
EXP_A_TXP3	C98	0.1u/4Y5V/16V/Z	EXP_A_TXP3C
EXP_A_TXN3	C99	0.1u/4Y5V/16V/Z	EXP_A_TXN3C
EXP_A_TXP4	C100	0.1u/4Y5V/16V/Z	EXP_A_TXP4C
EXP_A_TXN4	C101	0.1u/4Y5V/16V/Z	EXP_A_TXN4C
EXP_A_TXP5	C102	0.1u/4Y5V/16V/Z	EXP_A_TXP5C
EXP_A_TXN5	C103	0.1u/4Y5V/16V/Z	EXP_A_TXN5C
EXP_A_TXP6	C104	0.1u/4Y5V/16V/Z	EXP_A_TXP6C
EXP_A_TXN6	C105	0.1u/4Y5V/16V/Z	EXP_A_TXN6C
EXP_A_TXP7	C106	0.1u/4Y5V/16V/Z	EXP_A_TXP7C
EXP_A_TXN7	C107	0.1u/4Y5V/16V/Z	EXP_A_TXN7C
EXP_A_TXP8	C108	0.1u/4Y5V/16V/Z	EXP_A_TXP8C
EXP_A_TXN8	C109	0.1u/4Y5V/16V/Z	EXP_A_TXN8C
EXP_A_TXP9	C110	0.1u/4Y5V/16V/Z	EXP_A_TXP9C
EXP_A_TXN9	C111	0.1u/4Y5V/16V/Z	EXP_A_TXN9C
EXP_A_TXP10	C112	0.1u/4Y5V/16V/Z	EXP_A_TXP10C
EXP_A_TXN10	C113	0.1u/4Y5V/16V/Z	EXP_A_TXN10C
EXP_A_TXP11	C114	0.1u/4Y5V/16V/Z	EXP_A_TXP11C
EXP_A_TXN11	C115	0.1u/4Y5V/16V/Z	EXP_A_TXN11C
EXP_A_TXP12	C116	0.1u/4Y5V/16V/Z	EXP_A_TXP12C
EXP_A_TXN12	C117	0.1u/4Y5V/16V/Z	EXP_A_TXN12C
EXP_A_TXP13	C118	0.1u/4Y5V/16V/Z	EXP_A_TXP13C
EXP_A_TXN13	C119	0.1u/4Y5V/16V/Z	EXP_A_TXN13C
EXP_A_TXP14	C120	0.1u/4Y5V/16V/Z	EXP_A_TXP14C
EXP_A_TXN14	C121	0.1u/4Y5V/16V/Z	EXP_A_TXN14C
EXP_A_TXP15	C122	0.1u/4Y5V/16V/Z	EXP_A_TXP15C
EXP_A_TXN15	C123	0.1u/4Y5V/16V/Z	EXP_A_TXN15C

EXP_A_RXP0	SR1	04/SHT/X	EXP_A_RXP0C
EXP_A_RXN0	SR2	04/SHT/X	EXP_A_RXN0C
EXP_A_RXP1	SR3	04/SHT/X	EXP_A_RXP1C
EXP_A_RXN1	SR4	04/SHT/X	EXP_A_RXN1C
EXP_A_RXP2	SR5	04/SHT/X	EXP_A_RXP2C
EXP_A_RXN2	SR6	04/SHT/X	EXP_A_RXN2C
EXP_A_RXP3	SR7	04/SHT/X	EXP_A_RXP3C
EXP_A_RXN3	SR8	04/SHT/X	EXP_A_RXN3C
EXP_A_RXP4	SR9	04/SHT/X	EXP_A_RXP4C
EXP_A_RXN4	SR10	04/SHT/X	EXP_A_RXN4C
EXP_A_RXP5	SR11	04/SHT/X	EXP_A_RXP5C
EXP_A_RXN5	SR12	04/SHT/X	EXP_A_RXN5C
EXP_A_RXP6	SR13	04/SHT/X	EXP_A_RXP6C
EXP_A_RXN6	SR14	04/SHT/X	EXP_A_RXN6C
EXP_A_RXP7	SR15	04/SHT/X	EXP_A_RXP7C
EXP_A_RXN7	SR16	04/SHT/X	EXP_A_RXN7C
EXP_A_RXP8	SR17	04/SHT/X	EXP_A_RXP8C
EXP_A_RXN8	SR18	04/SHT/X	EXP_A_RXN8C
EXP_A_RXP9	SR19	04/SHT/X	EXP_A_RXP9C
EXP_A_RXN9	SR20	04/SHT/X	EXP_A_RXN9C
EXP_A_RXP10	SR21	04/SHT/X	EXP_A_RXP10C
EXP_A_RXN10	SR22	04/SHT/X	EXP_A_RXN10C
EXP_A_RXP11	SR23	04/SHT/X	EXP_A_RXP11C
EXP_A_RXN11	SR24	04/SHT/X	EXP_A_RXN11C
EXP_A_RXP12	SR25	04/SHT/X	EXP_A_RXP12C
EXP_A_RXN12	SR26	04/SHT/X	EXP_A_RXN12C
EXP_A_RXP13	SR27	04/SHT/X	EXP_A_RXP13C
EXP_A_RXN13	SR28	04/SHT/X	EXP_A_RXN13C
EXP_A_RXP14	SR29	04/SHT/X	EXP_A_RXP14C
EXP_A_RXN14	SR30	04/SHT/X	EXP_A_RXN14C
EXP_A_RXP15	SR31	04/SHT/X	EXP_A_RXP15C
EXP_A_RXN15	SR32	04/SHT/X	EXP_A_RXN15C

[18] PCIE_OP0	PCIE_OP0	SR49	04/X	EXP_A_TXP0C
[18] PCIE_ON0	PCIE_ON0	SR50	04/X	EXP_A_TXN0C
[18] PCIE_OP1	PCIE_OP1	SR51	04/X	EXP_A_TXP1C
[18] PCIE_ON1	PCIE_ON1	SR52	04/X	EXP_A_TXN1C
[18] PCIE_OP2	PCIE_OP2	SR37	04/X	EXP_A_TXP2C
[18] PCIE_ON2	PCIE_ON2	SR38	04/X	EXP_A_TXN2C
[18] PCIE_OP3	PCIE_OP3	SR39	04/X	EXP_A_TXP3C
[18] PCIE_ON3	PCIE_ON3	SR40	04/X	EXP_A_TXN3C

[18] PCIE_IP0	PCIE_IP0	SR53	04/X	EXP_A_RXP0C
[18] PCIE_IN0	PCIE_IN0	SR54	04/X	EXP_A_RXN0C
[18] PCIE_IP1	PCIE_IP1	SR55	04/X	EXP_A_RXP1C
[18] PCIE_IN1	PCIE_IN1	SR56	04/X	EXP_A_RXN1C
[18] PCIE_IP2	PCIE_IP2	SR45	04/X	EXP_A_RXP2C
[18] PCIE_IN2	PCIE_IN2	SR46	04/X	EXP_A_RXN2C
[18] PCIE_IP3	PCIE_IP3	SR47	04/X	EXP_A_RXP3C
[18] PCIE_IN3	PCIE_IN3	SR48	04/X	EXP_A_RXN3C

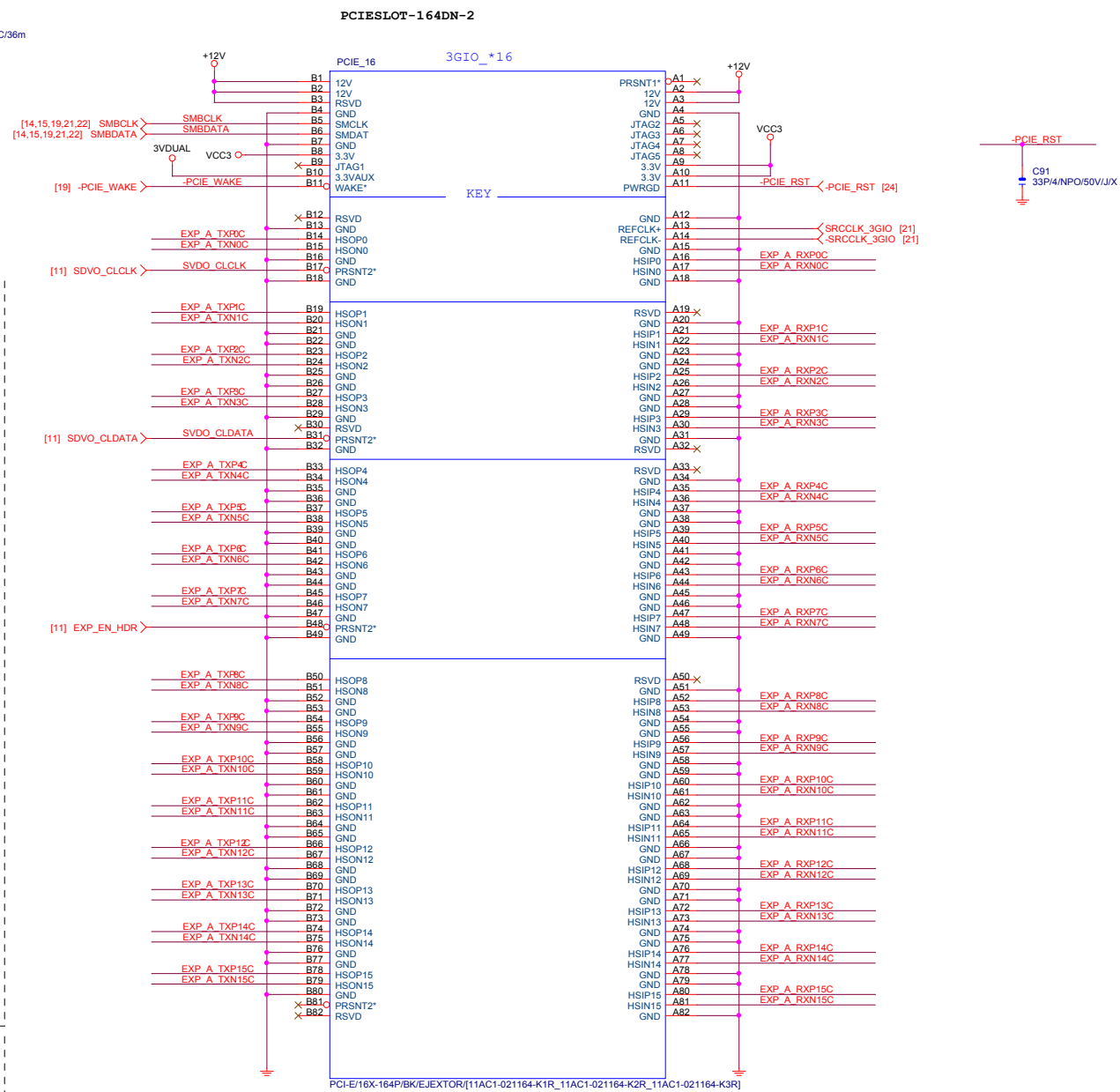

PCIE-E16X-164P/BK/EJEXTOR[T11AC1-021164-K1R_11AC1-021164-K2R_11AC1-021164-K3R]

Gigabyte Technology

PCI EXPRESS * 16

Title	Document Number	Rev
	945GCM-S2	3.0
Date:	Wednesday, January 03, 2007	Sheet 17 of 33

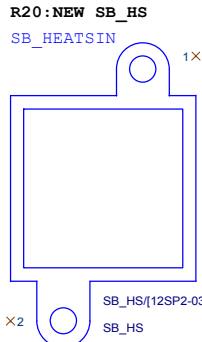
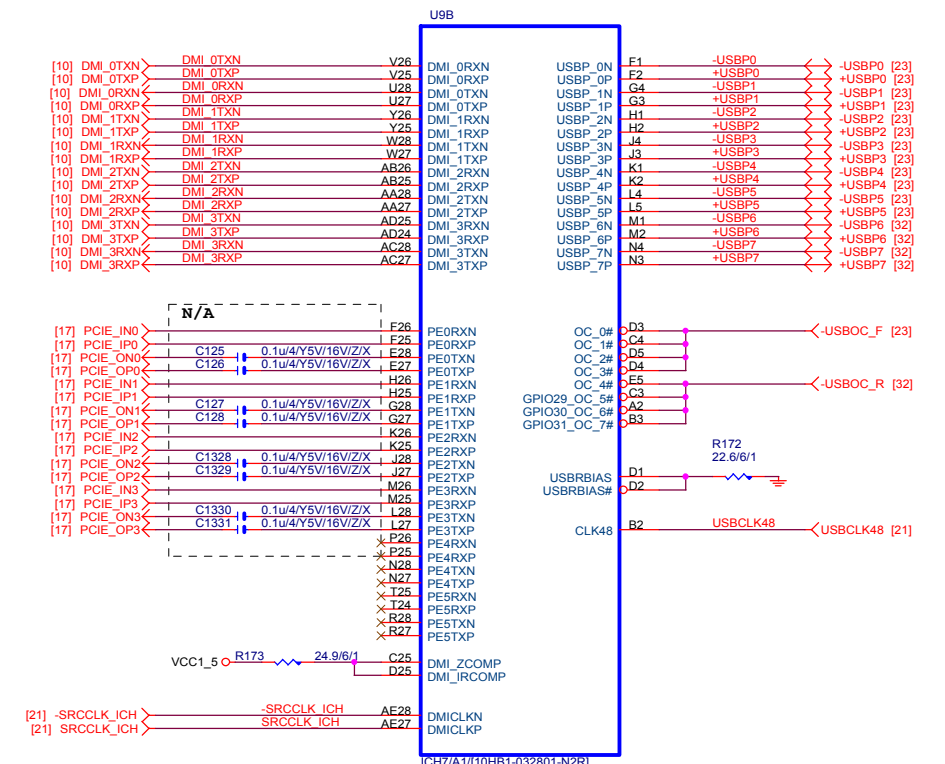
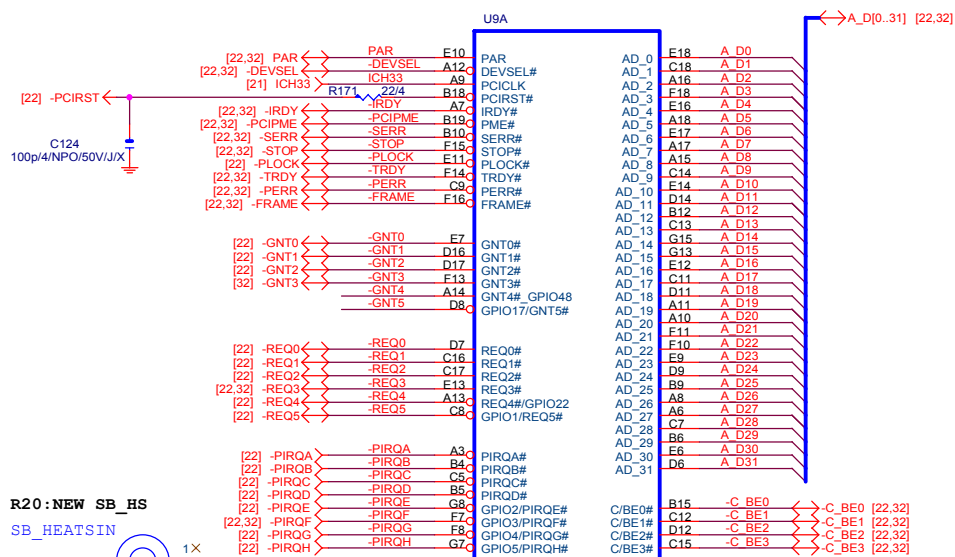

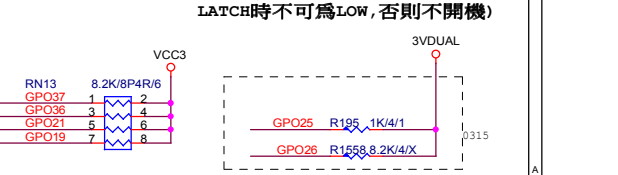
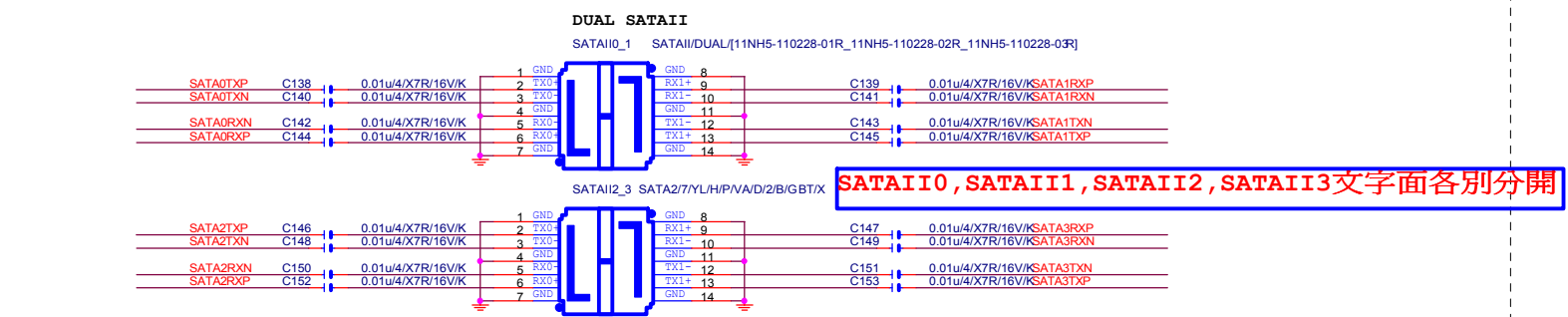
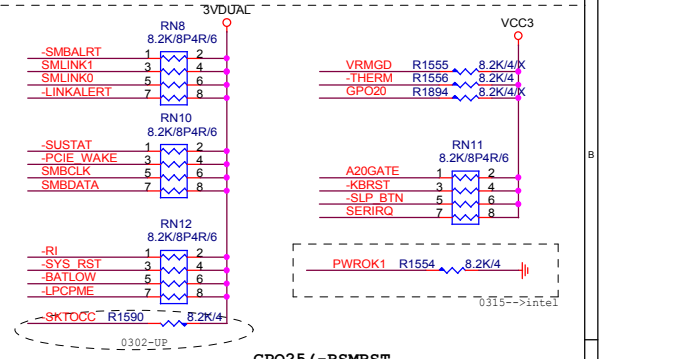
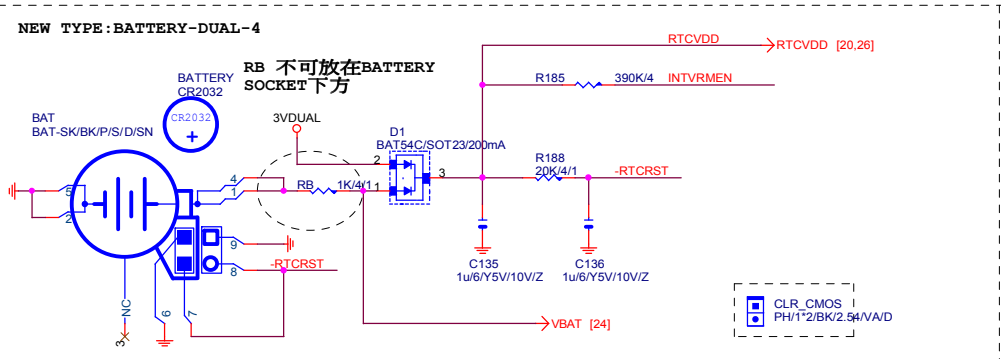
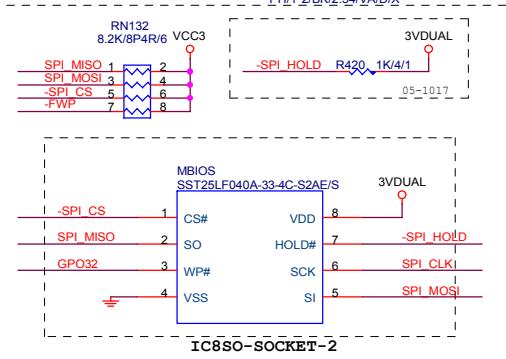
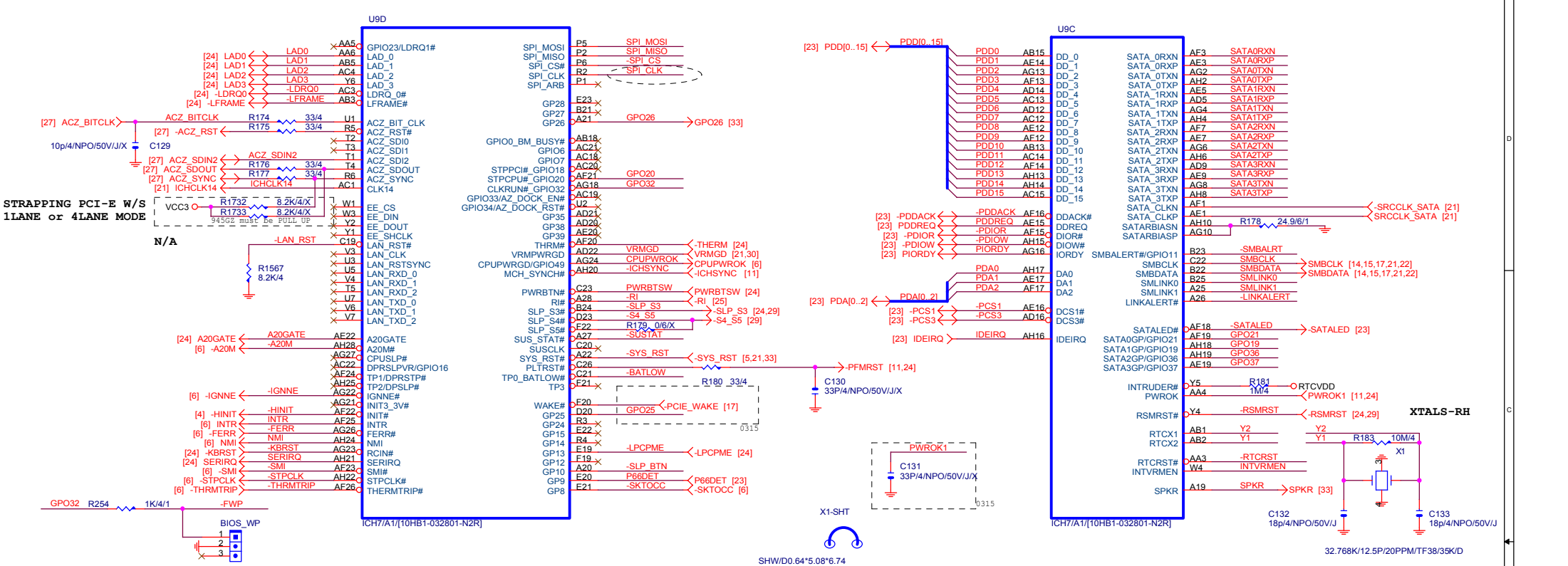

U9F		
A4	VSS1	R14
A23	VSS2	R15
B1	VSS3	R16
B8	VSS4	R17
B11	VSS5	R18
B14	VSS6	T6
B17	VSS7	T12
B20	VSS8	T13
B26	VSS9	T14
B28	VSS10	T15
C2	VSS11	T16
C6	VSS12	T17
D10	VSS13	U4
D13	VSS14	U12
D18	VSS15	U13
D21	VSS16	U14
D24	VSS17	U15
E1	VSS18	U16
E2	VSS19	U17
E8	VSS20	U24
E15	VSS21	U25
F3	VSS22	U26
F4	VSS23	U27
F12	VSS24	U28
F27	VSS25	V24
F28	VSS27	V27
G1	VSS28	V28
G2	VSS29	W6
G5	VSS30	W24
G6	VSS31	W25
G9	VSS32	W26
G14	VSS33	Y3
G18	VSS34	Y24
G21	VSS35	Y27
G24	VSS36	Y28
G25	VSS37	AA1
G26	VSS38	AA24
H3	VSS39	AA25
H4	VSS40	AA26
H5	VSS41	AB4
H24	VSS42	AB6
H27	VSS43	AB11
H28	VSS44	AB14
J1	VSS45	AB16
J2	VSS46	AB19
J5	VSS47	AB21
J24	VSS48	AB24
J25	VSS49	AB27
J26	VSS50	AB28
K24	VSS51	AC2
K27	VSS52	AC5
K28	VSS53	AC9
L13	VSS54	AC11
L15	VSS55	AD1
L24	VSS56	AD3
L25	VSS57	AD4
L26	VSS58	AD7
M3	VSS59	AD8
M4	VSS60	AD15
M5	VSS61	AD19
M12	VSS62	AD23
M13	VSS63	AE2
M14	VSS64	AE4
M15	VSS65	AE8
M16	VSS66	AE11
M17	VSS67	AE13
M24	VSS68	AE18
M27	VSS69	AE21
M28	VSS70	AE24
N1	VSS71	AE25
N2	VSS72	AF2
N5	VSS73	AF4
N6	VSS74	AF8
N11	VSS75	AF11
N12	VSS76	AF27
N13	VSS77	AF29
N14	VSS78	AG1
N15	VSS79	AG3
N16	VSS80	AG7
N17	VSS81	AG14
N18	VSS82	AG17
N24	VSS83	AG20
N26	VSS84	AG25
P3	VSS85	AH1
P4	VSS86	AH3
P12	VSS88	AH7
P13	VSS89	AH12
P14	VSS90	AH23
P15	VSS91	AH27
P16	VSS92	C27
P17	VSS93	E4
P24	VSS94	AG11
P27	VSS95	
P28	VSS96	
R1	VSS97	
R11	VSS98	
R12	VSS99	
R13	VSS100	

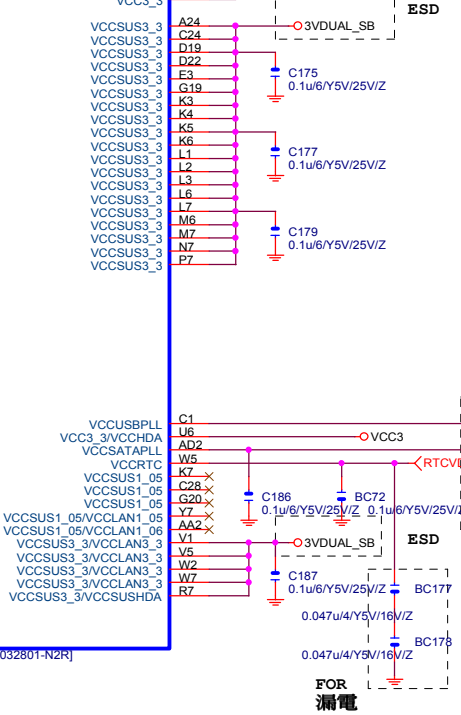
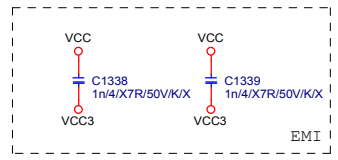
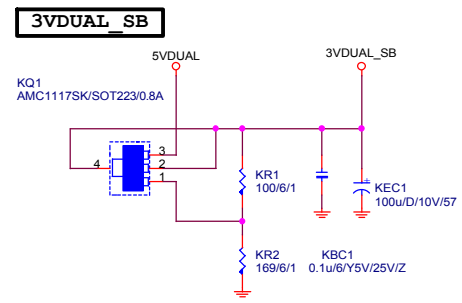
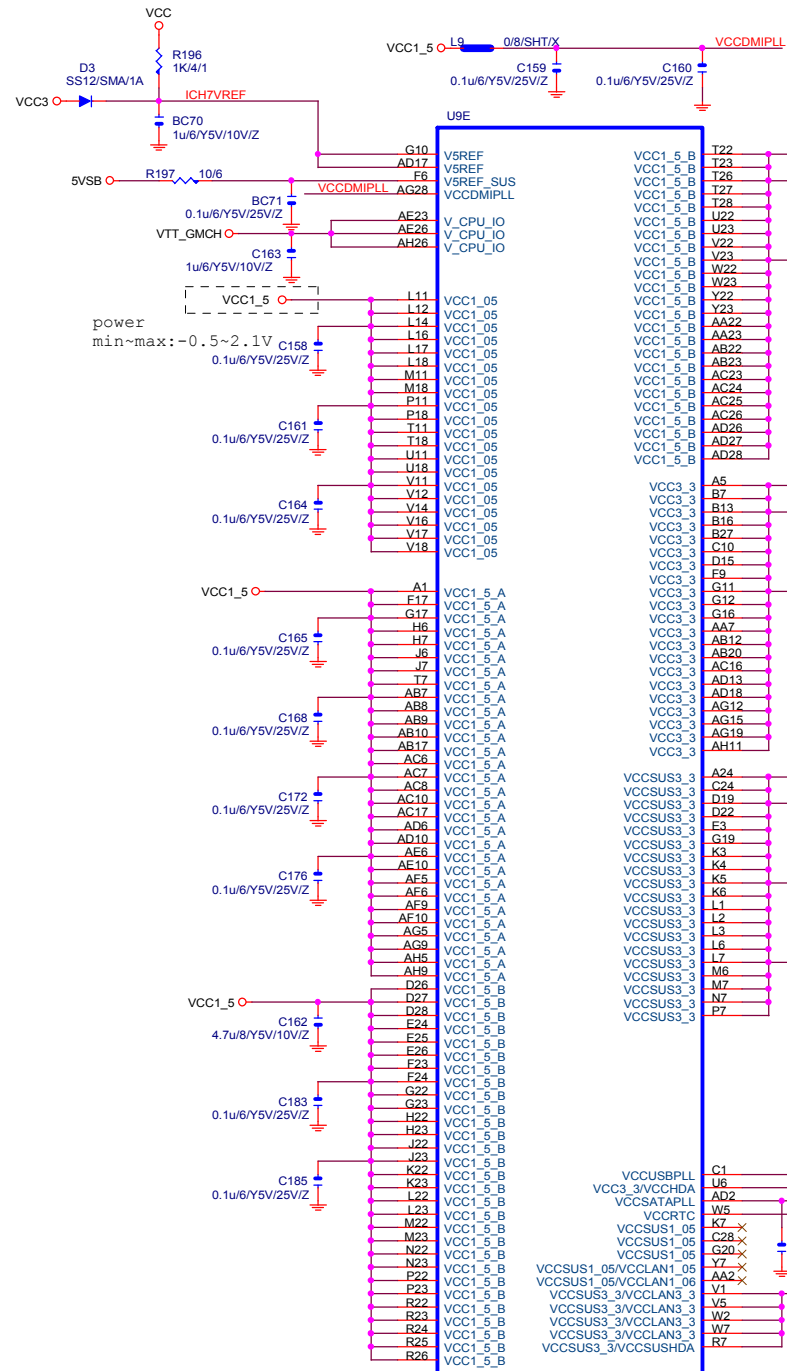

Gigabyte Technology		
ICH7-PWR & GND		
Title	Document Number	Rev
	945GCM-S2	3.0
Date:	Wednesday, January 03, 2007	Sheet 20 of 33

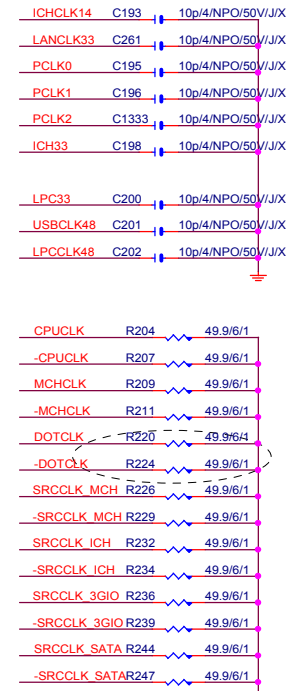
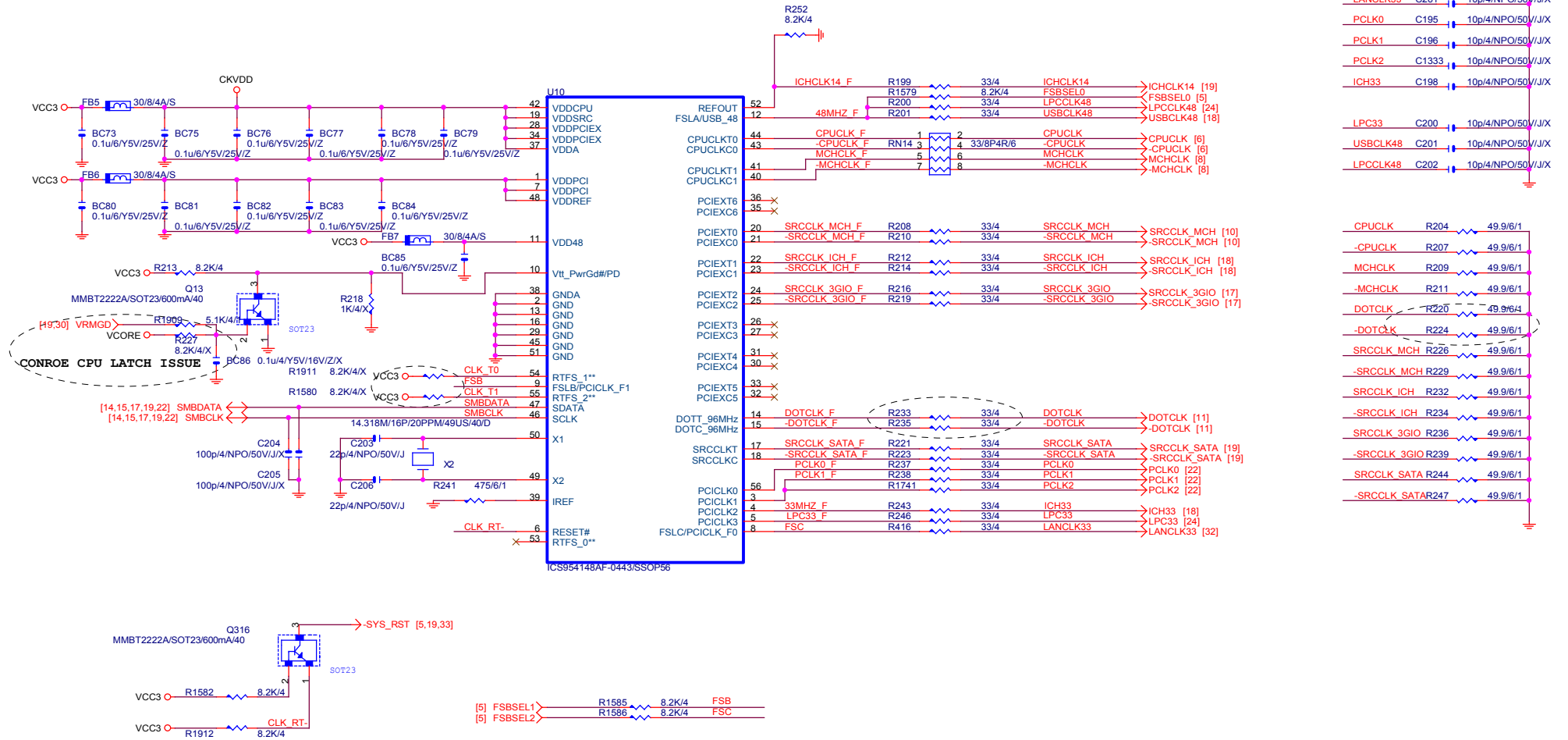

PCI1, 2 SLOT

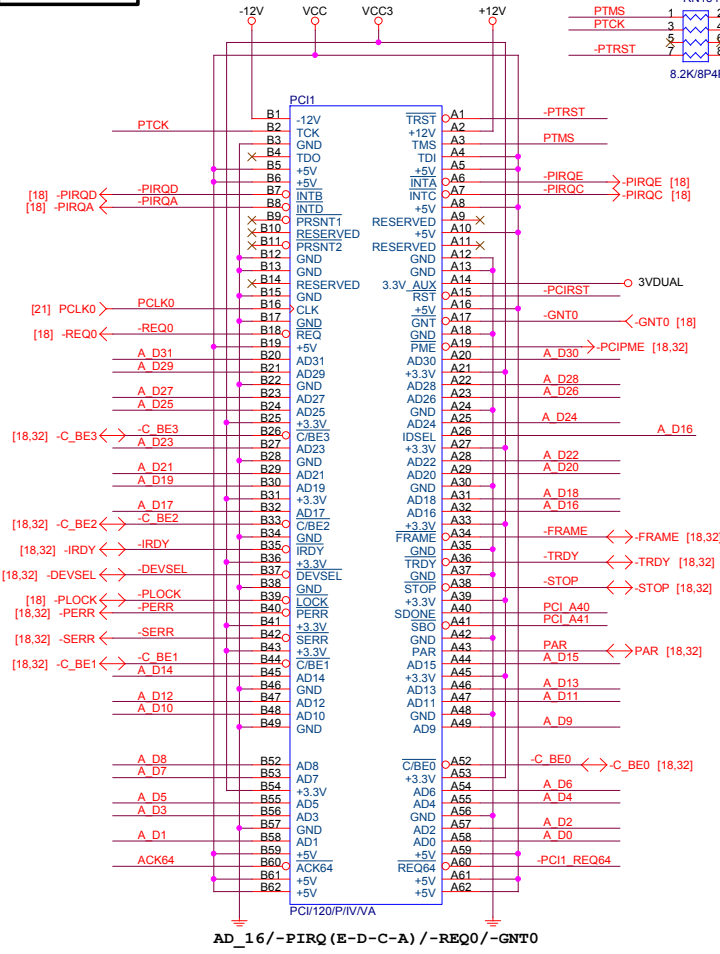

AD_16/-PIRQ (E-D-C-A) /-REQ0/-GNT0

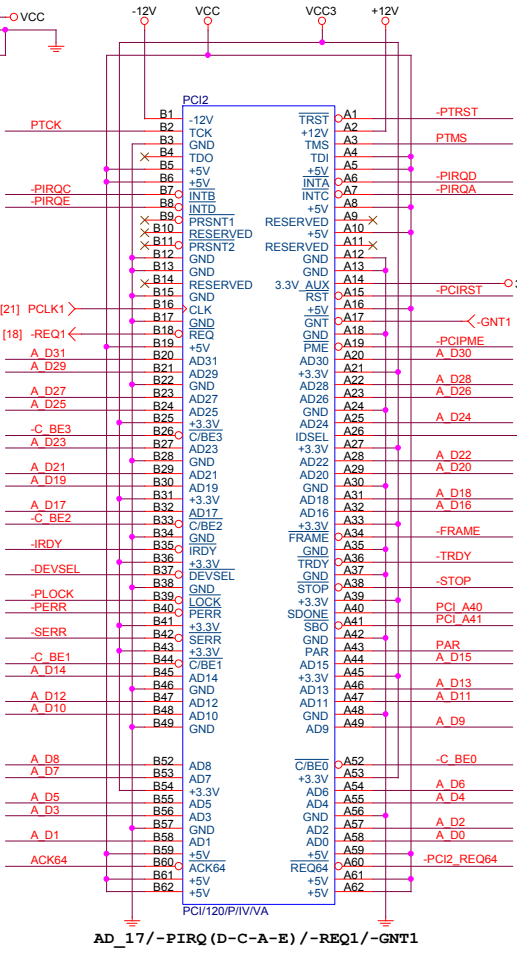

AD_17/-PIRQ (D-C-A-E) /-REQ1/-GNT1

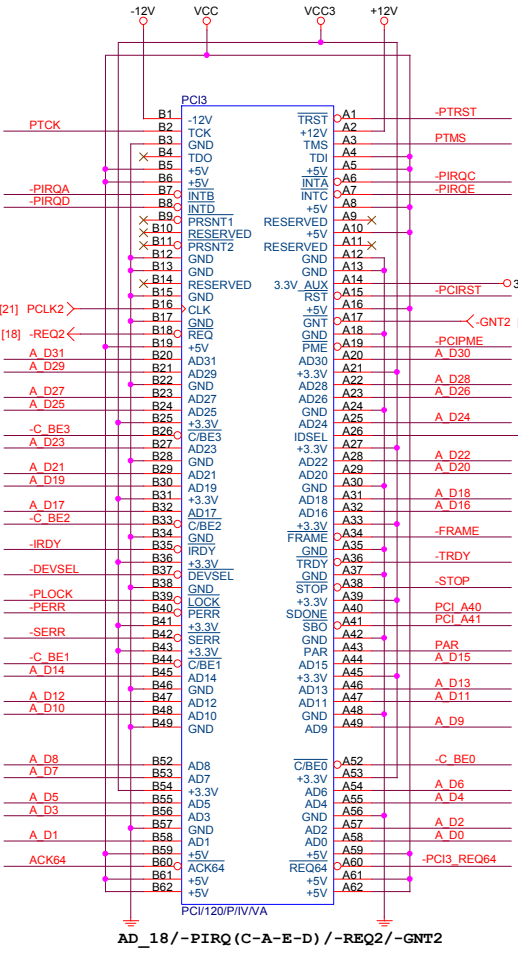

AD_18/-PIRQ (C-A-E-D) /-REQ2/-GNT2

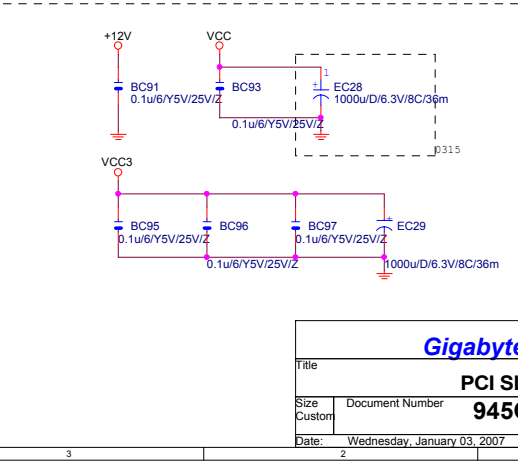
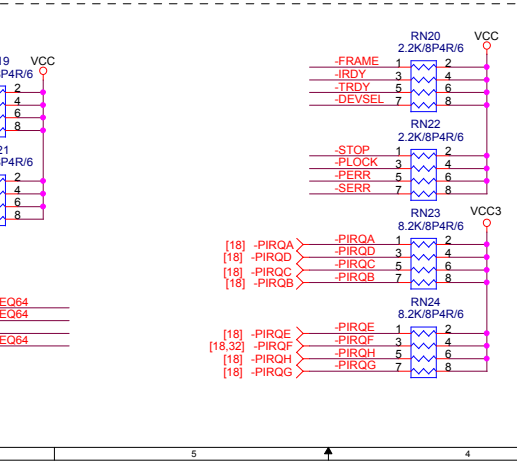
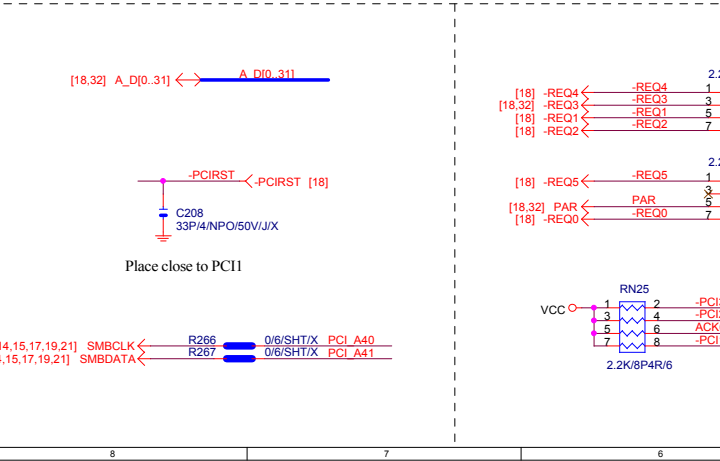

Gigabyte Technology

PCI SLOT 1, 2/PCIEX1

945GCM-S2

File	Document Number	Rev
Size	945GCM-S2	3.0
Customer		
Date:	Wednesday, January 03, 2007	Sheet 22 of 33

IDE/SATA LED

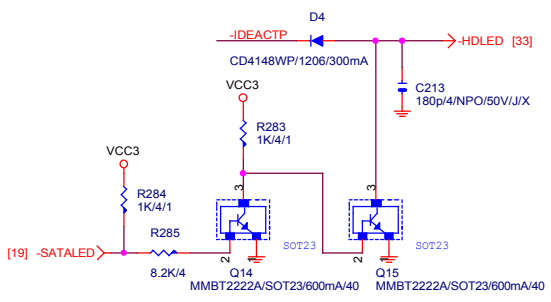

IDE RESET

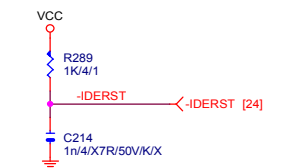

FLOPPY

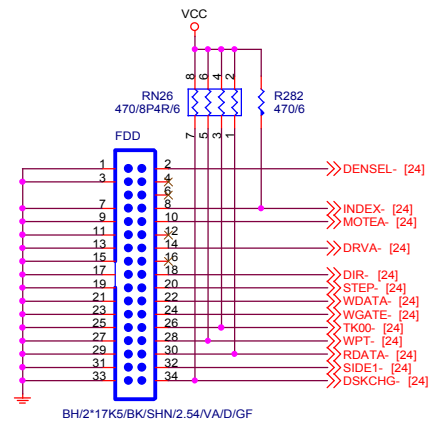

IDE

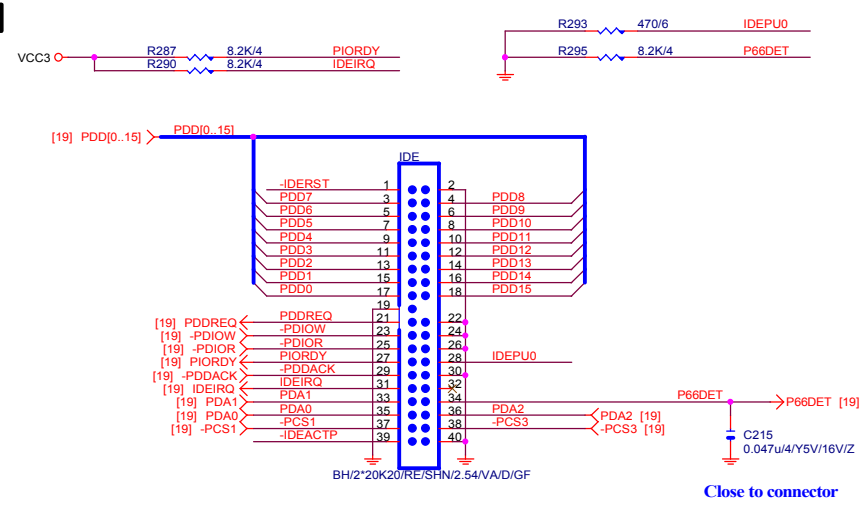

FRONT USB1

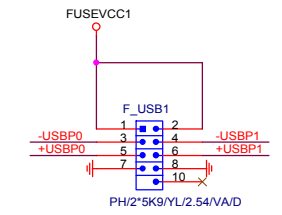

FRONT USB2

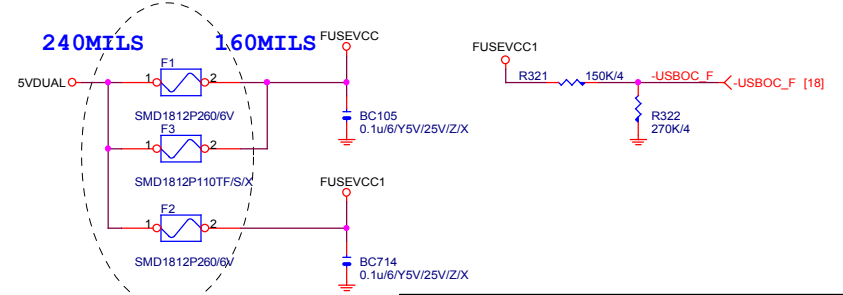
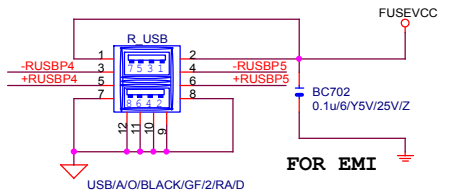
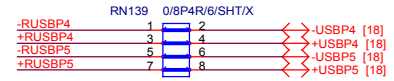
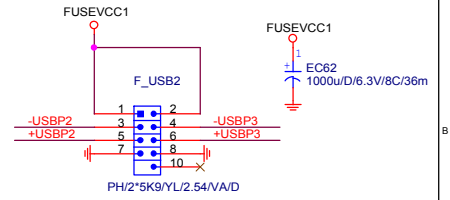

RTS2- ==LOW CPU FAN 50%
 ==HIGH 100%
DEFAULT 50%

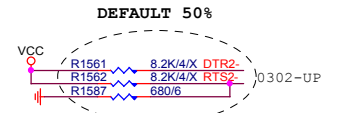

SOUT2	1	VID pins threshold voltage select: Vih / Vil : 2.0 / 0.8V
	0	VID pins threshold voltage select: Vih / Vil : 0.8 / 0.4V



- [25] DTR2- << 32
- [25] RTS2- << 33
- [25] DSR2 << 34
- [25] DSR2 << [GP64]
- VCC << 35
- [25] TXD2 << 36
- [25] RXD2 << 37
- [33] FANIO1 << 38
- [33] FANPWM1 << 39
- [33] FANIO2 << 40
- [33] FANPWM3 << 41
- [30] IO_VID5 << 42
- [30] IO_VID4 << 43
- [30] IO_VID3 << 44
- [30] IO_VID2 << 45
- [30] IO_VID1 << 46
- [30] IO_VID0 << 47
- [30] IO_VID2 << 48
- [30] IO_VID1 << 49
- [30] IO_VID0 << 50

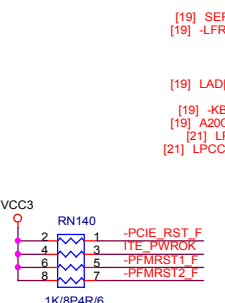
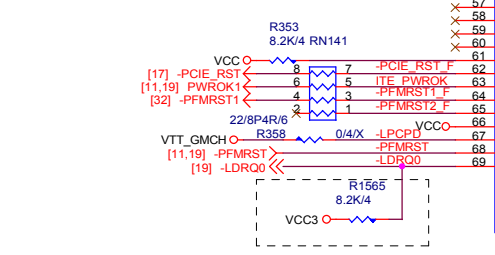

Dual BIOS:
 GB logo :Pin 61 (GP15/CSA)
 GB logo :Pin 59 (GP17/CSB)
 Pin 59 Dual BIOS ,Power On Strapping:
 H ==>Dual BIOS function Enable
 L ==>Dual BIOS function Disable

1.2V or 3.3V tolerance select.
 1.2V OUTPUT 接 VTT_GMCH
 3.3V OUTPUT 接 3.3V
 LPCPD#=#VIDVCC

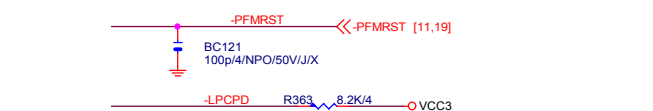
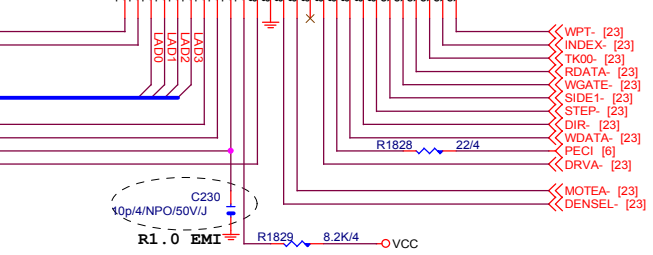
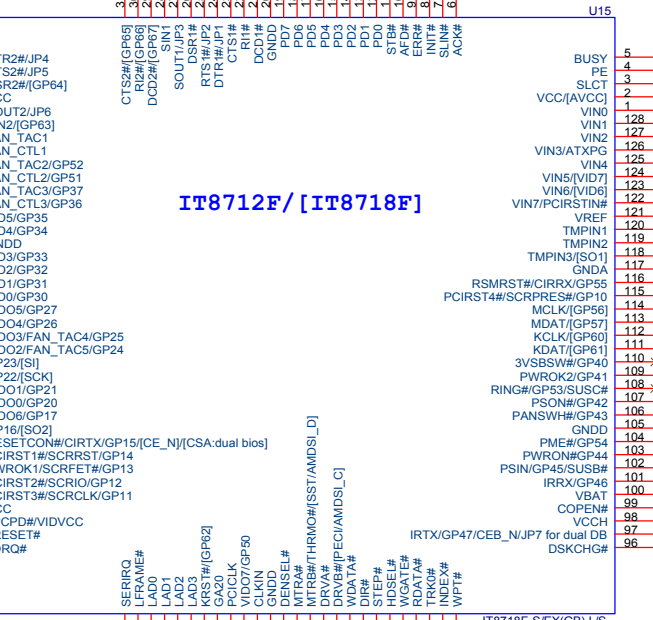
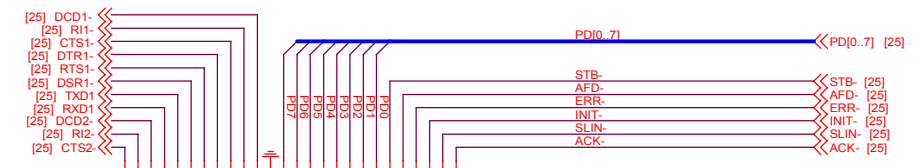

**JP7 : HIGH DUAL BIOS DISABLE
 LOW DUAL BIOS ENABLE**

COMA

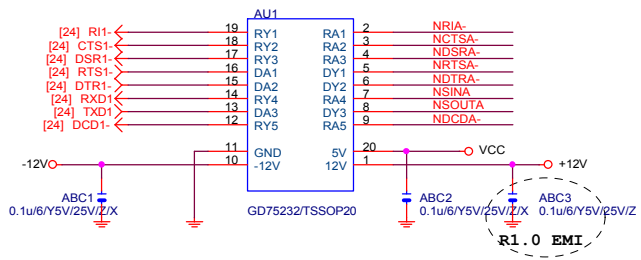

RING IN

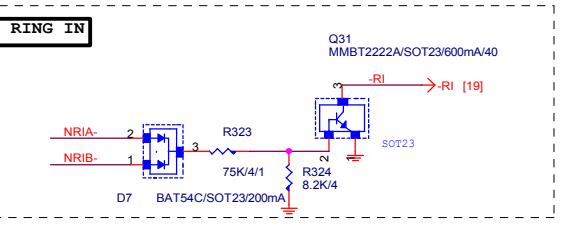

EXTERNAL COMA

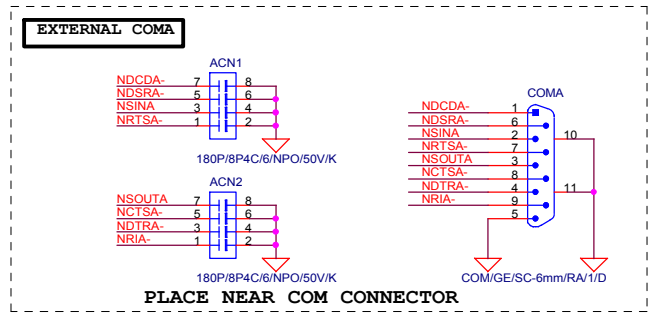

PLACE NEAR COM CONNECTOR

COMB

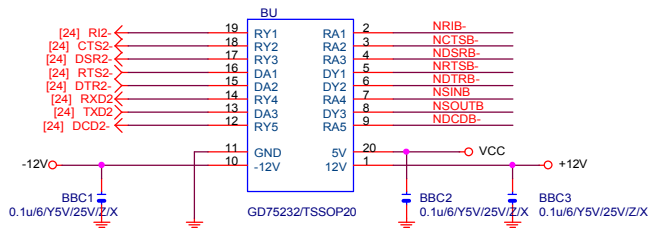

INTERNAL COMB

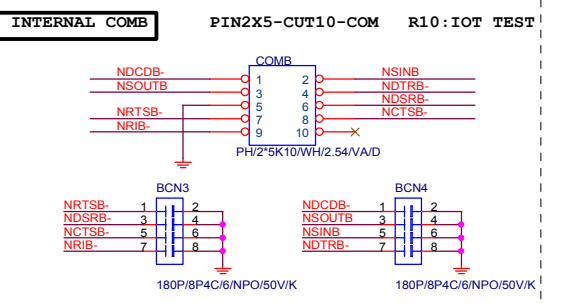

LPT PORT

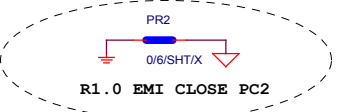
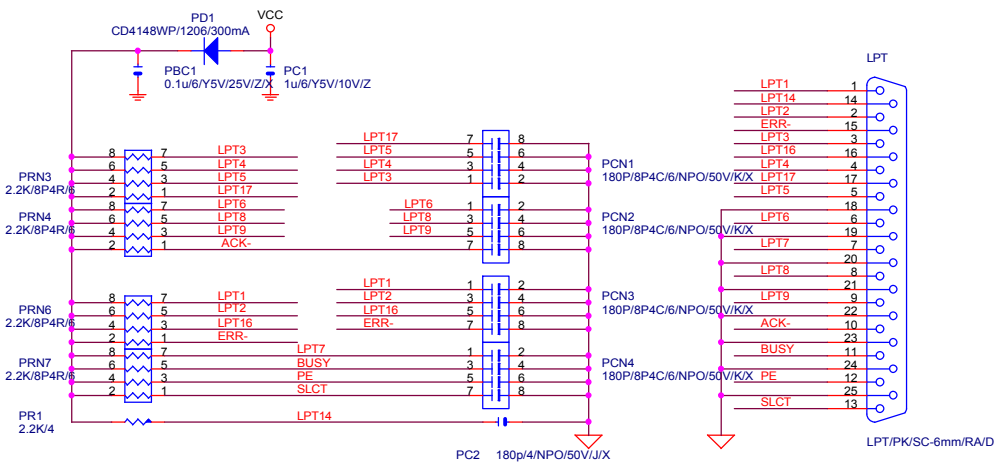
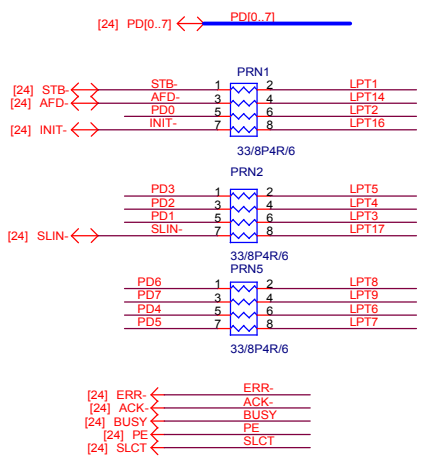

Gigabyte Technology		
COM & LPT PORT		
Title	Document Number	Rev
	945GCM-S2	3.0
Date:	Wednesday, January 03, 2007	Sheet 25 of 33

TEMP H/W MONITOR

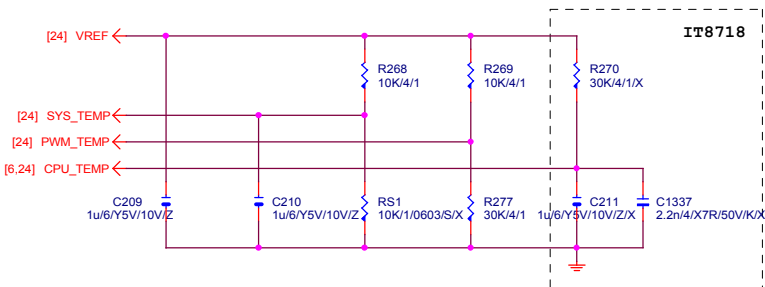

VOLTAGE-- H/W MONITOR

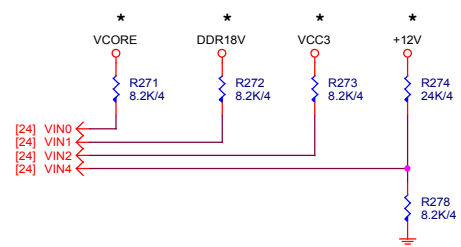

CASE OPEN

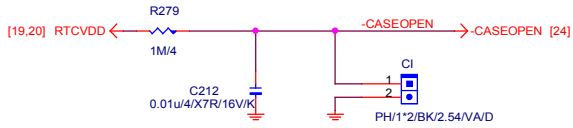

Case Open Circuits

KB/MS

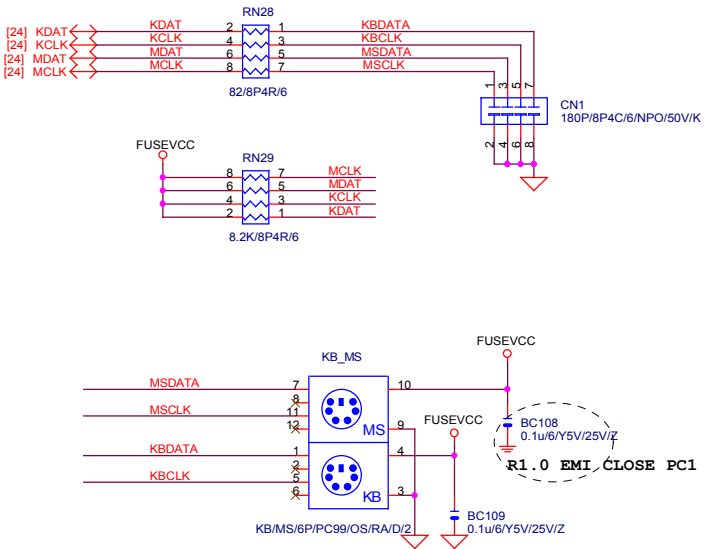

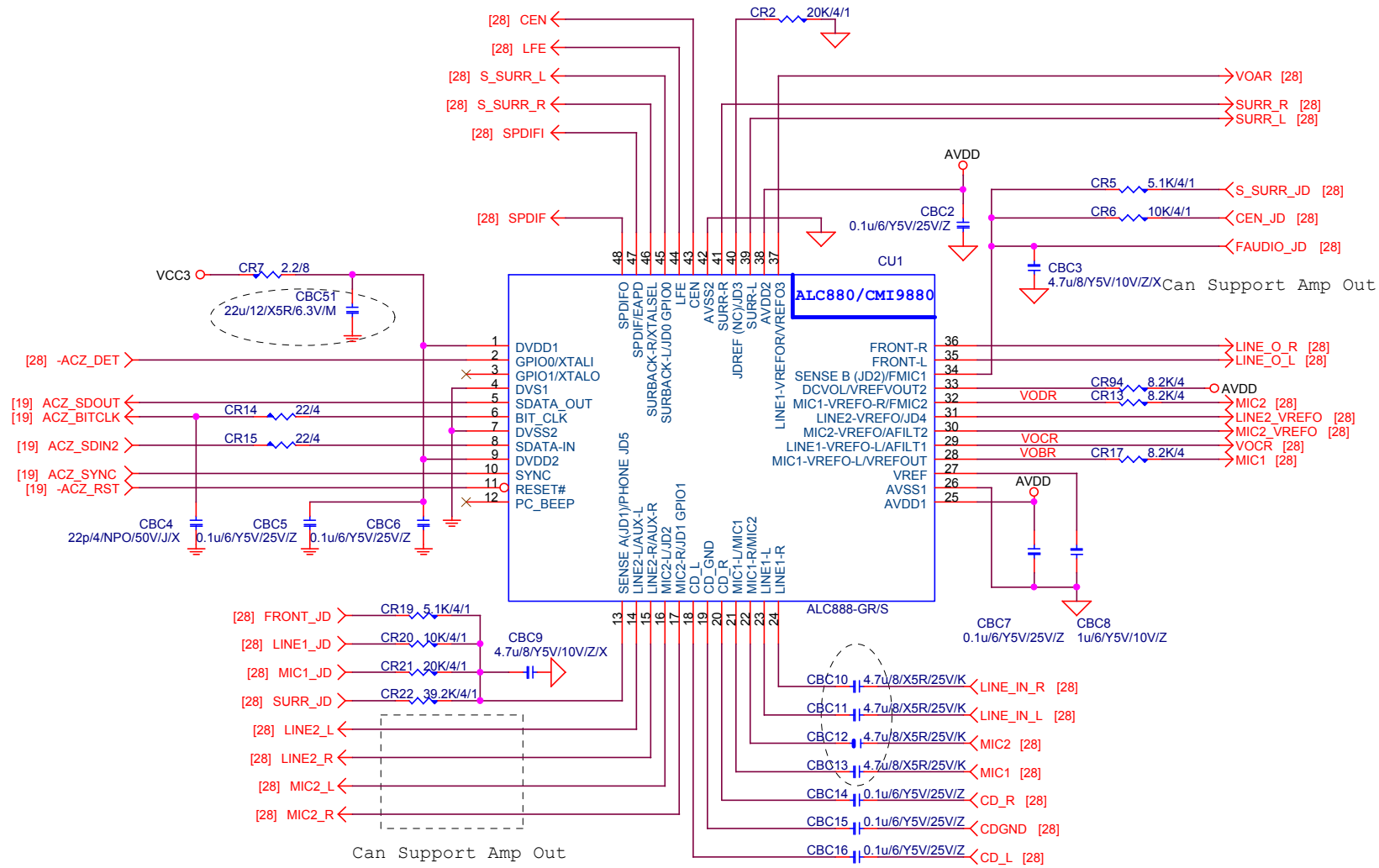

Gigabyte Technology

Title			AZALIA ALC888		
Size Custom	Document Number	945GCM-S2			Rev 3.0
Date:	Wednesday, January 03, 2007	Sheet	27	of	33

CODEC POWER/EMI PAD

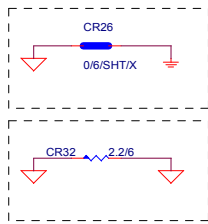
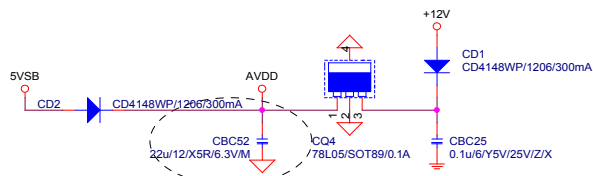

CD IN

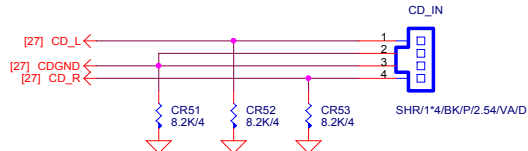

SPDIF

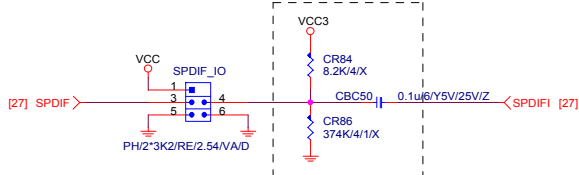

AZALIA JACK

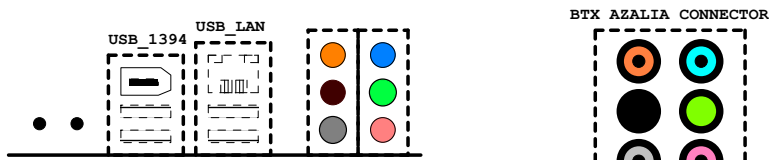

3RP/26P/OR, BK, GY, BU, GE, PK/RA/D/1/B
VISTA規範: REAR-->BLK, CEN/SUB-->ORG

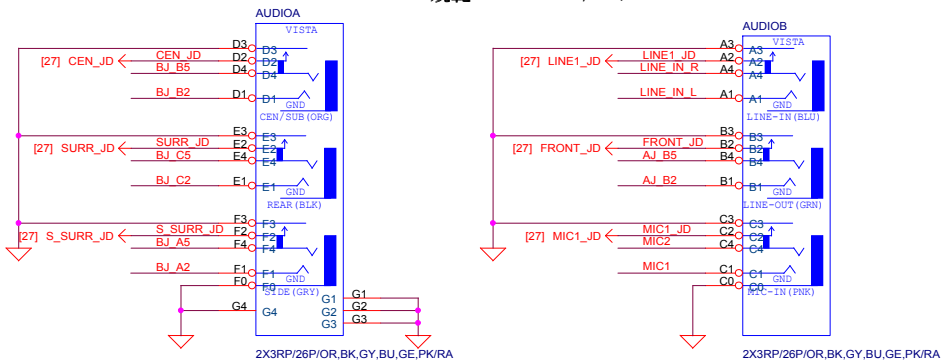

LINE-OUT

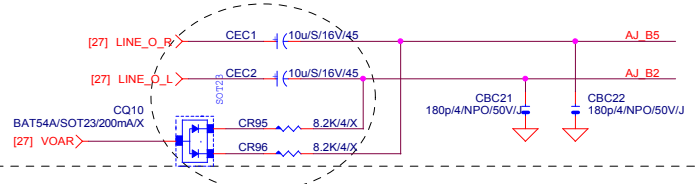

LINE-IN

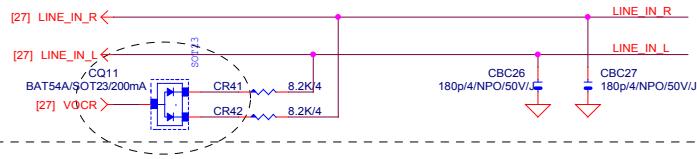

MIC-IN

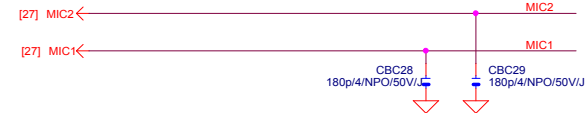

SURROUND

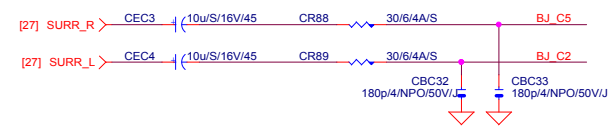

CEN/LFE

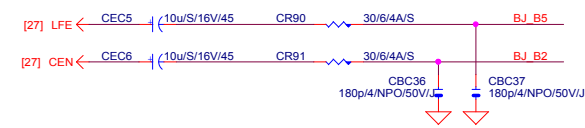

SURRBACK

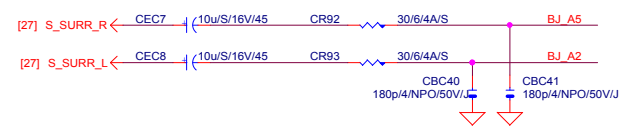

AZALIA FRONT PANEL

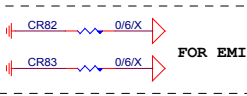
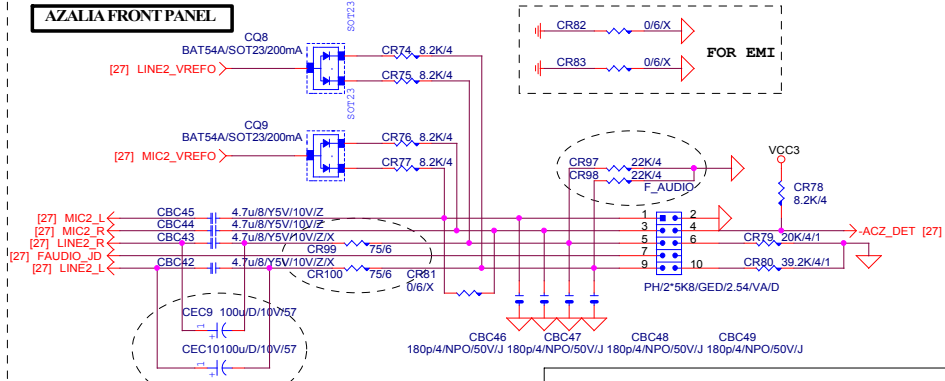

Gigabyte Technology			
AUDIO JACK			
945GCM-S2			
Title	Document Number	Rev	
Size	945GCM-S2	3.0	
Custom			
Date:	Wednesday, January 03, 2007	Sheet	28 of 33

3VDUAL

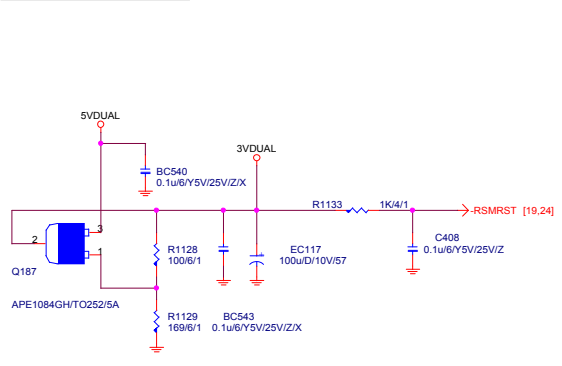

DDRVTT

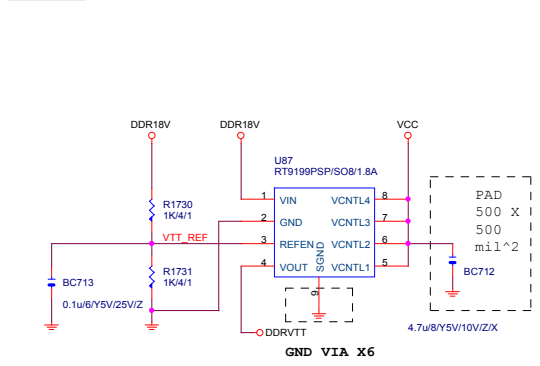

5VDUAL

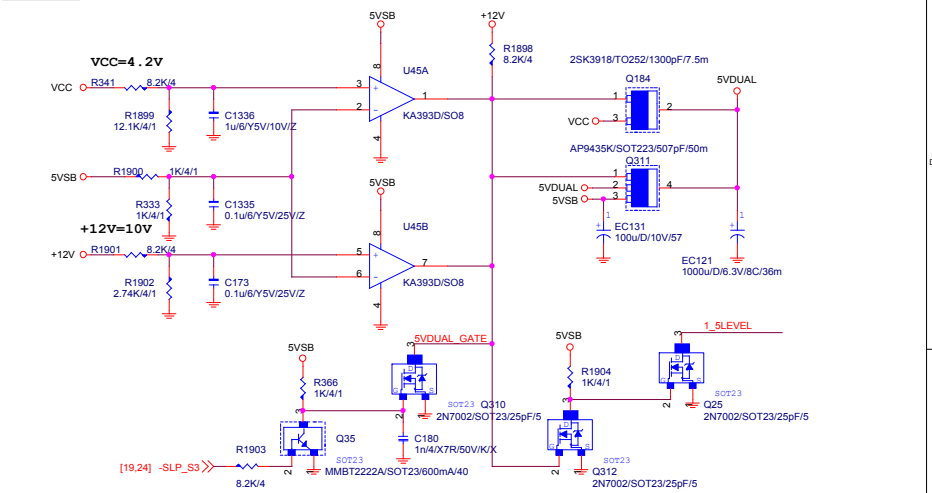

S3 TURN OFF 2 5LEVEL, 避免DDR18V DROP
 (DDR18V +12V 关断, 避免DDR18V DROP)
 ON, 导致DDR18V LOADING WORSE

DDR18V

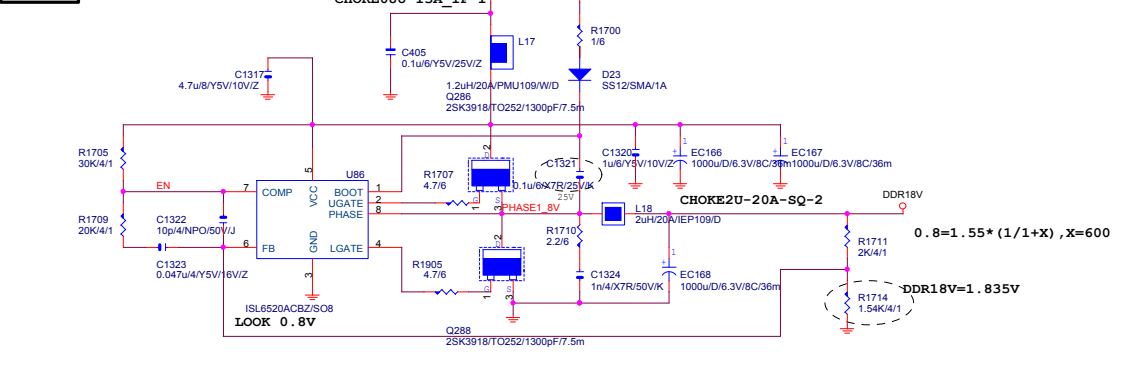

POWER

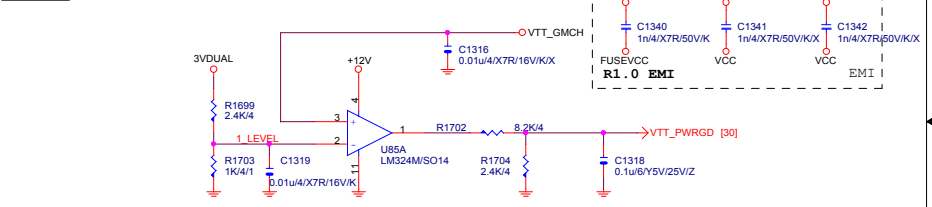

POWER SEQUENCE

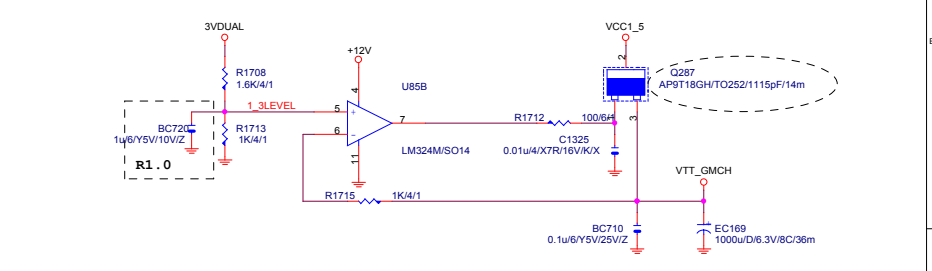
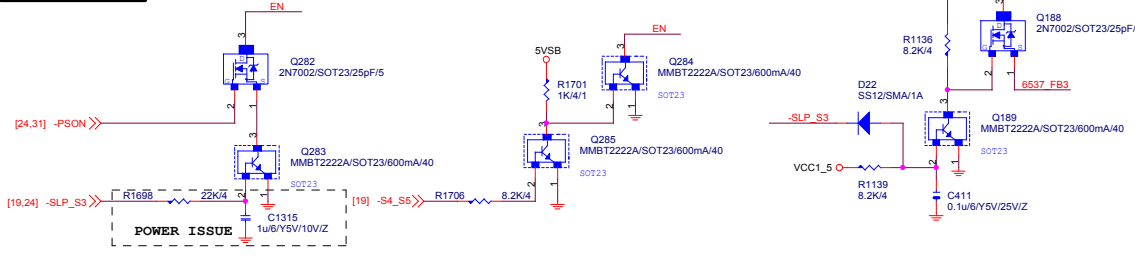

FIX DATA-SW ISSUE

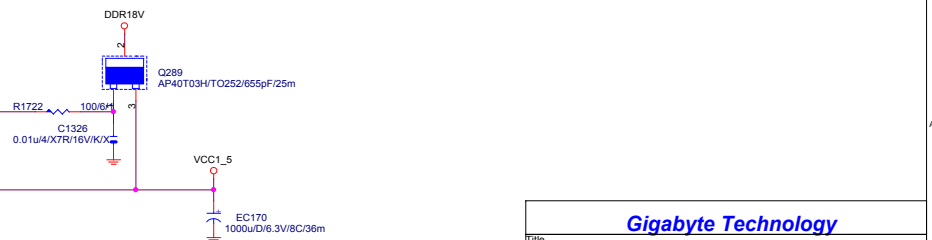
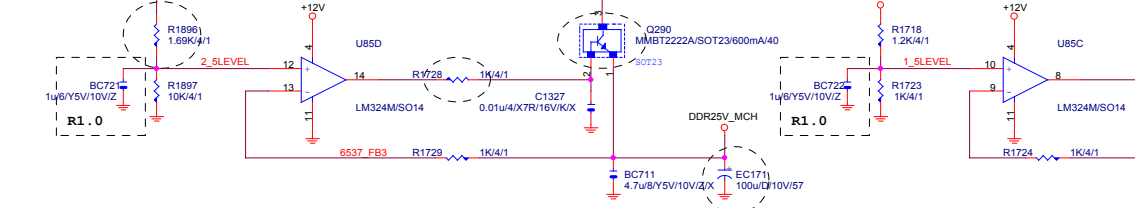

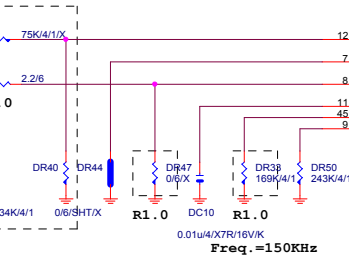
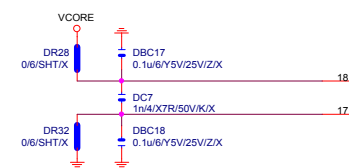
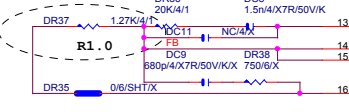
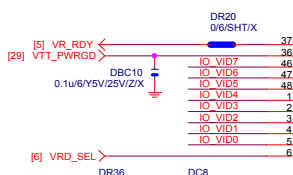
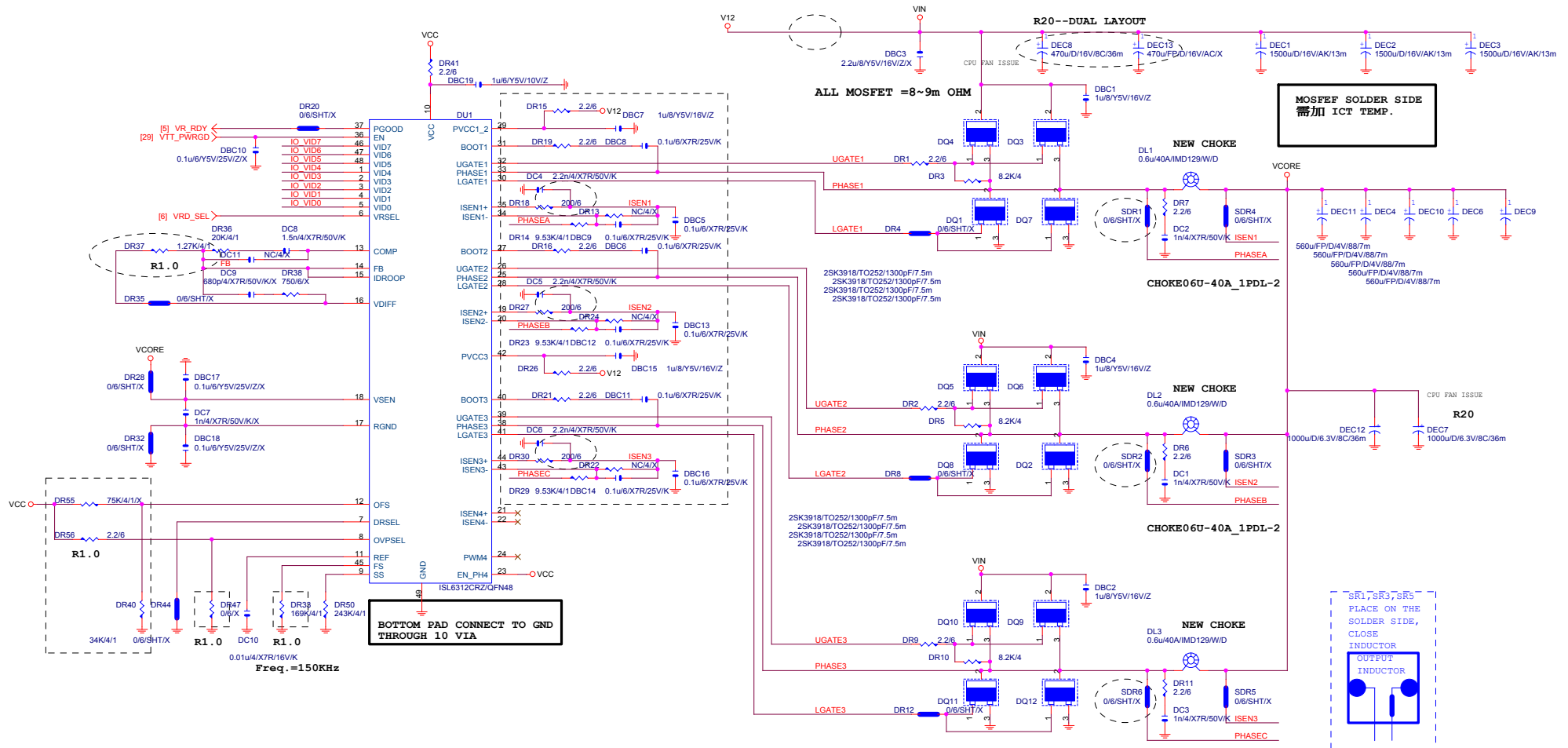

BOTTOM PAD CONNECT TO GND THROUGH 10 VIA

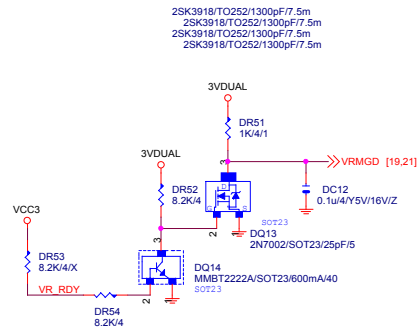
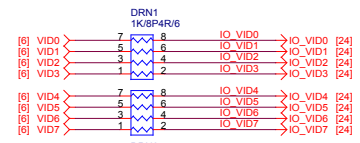

MOSFET SOLDER SIDE 帶加 ICT TEMP.

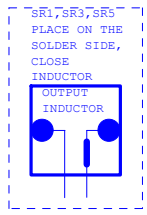

ATXPWR_24-2
ATX POWER CONNECTOR

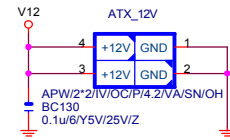
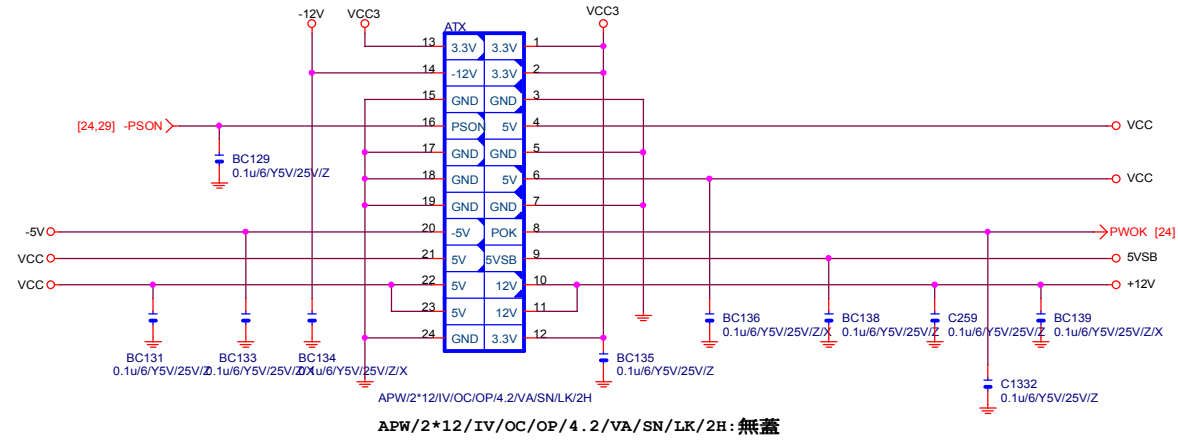

HOLE_3-RH-2

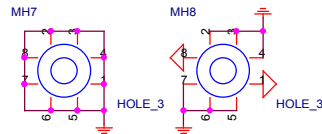
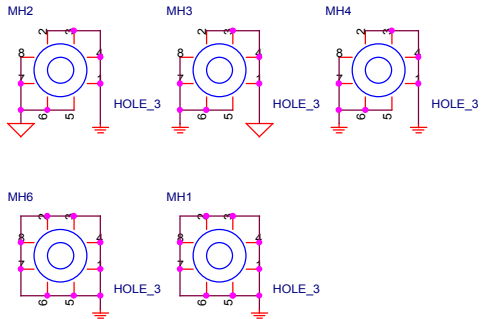

HOLE_3-RH-5MM

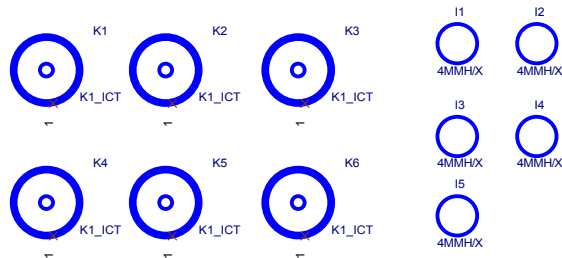

Gigabyte Technology		
ATX POWER CONNECTOR		
Size B	Document Number 945GCM-S2	Rev 3.0
Date: Wednesday, January 03, 2007	Sheet 31	of 33

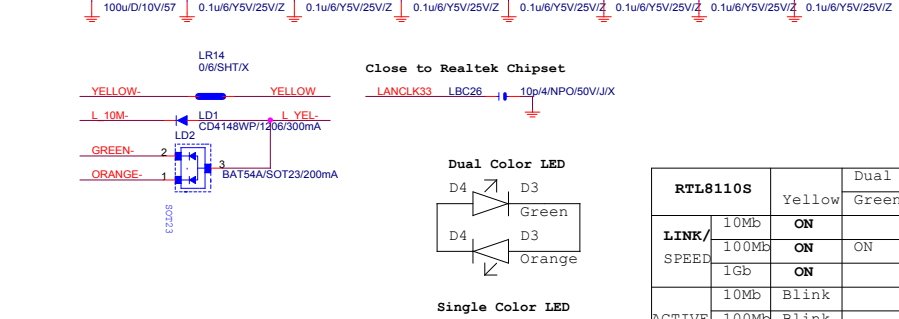
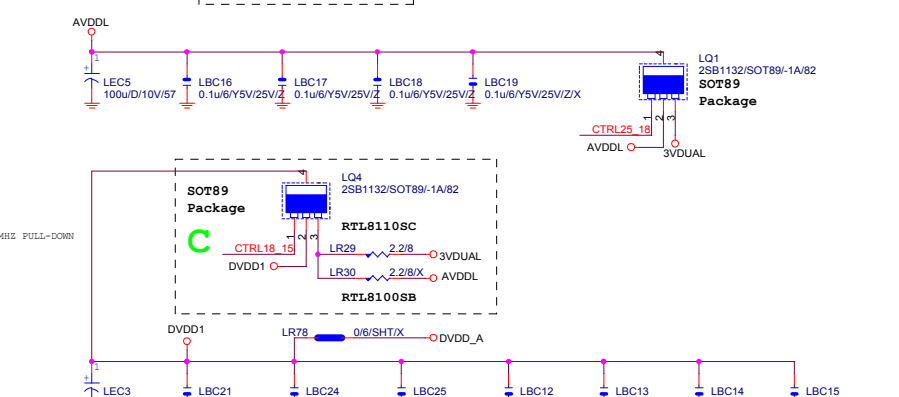
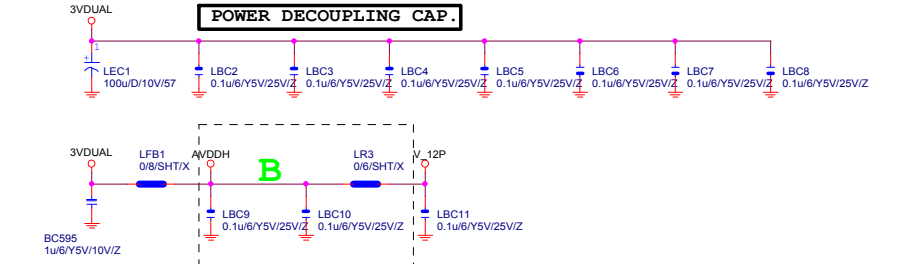
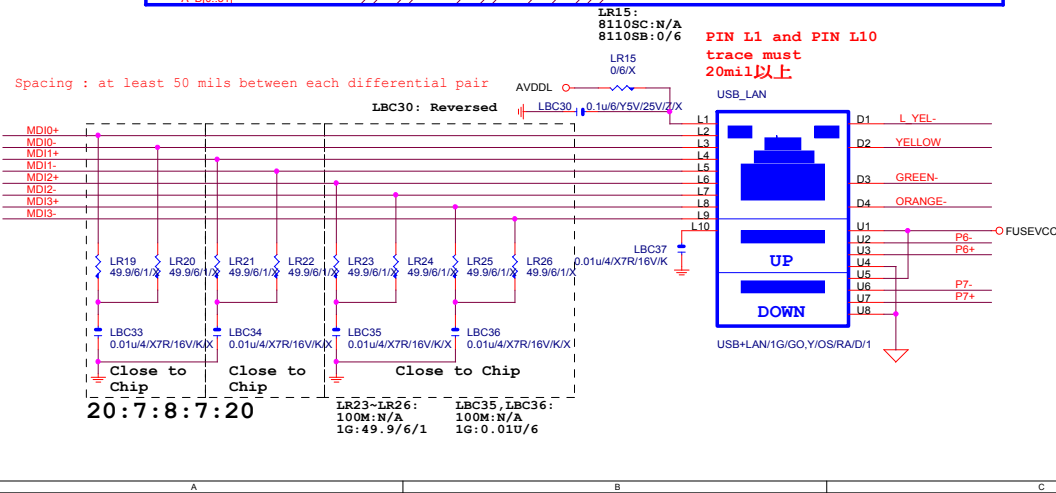
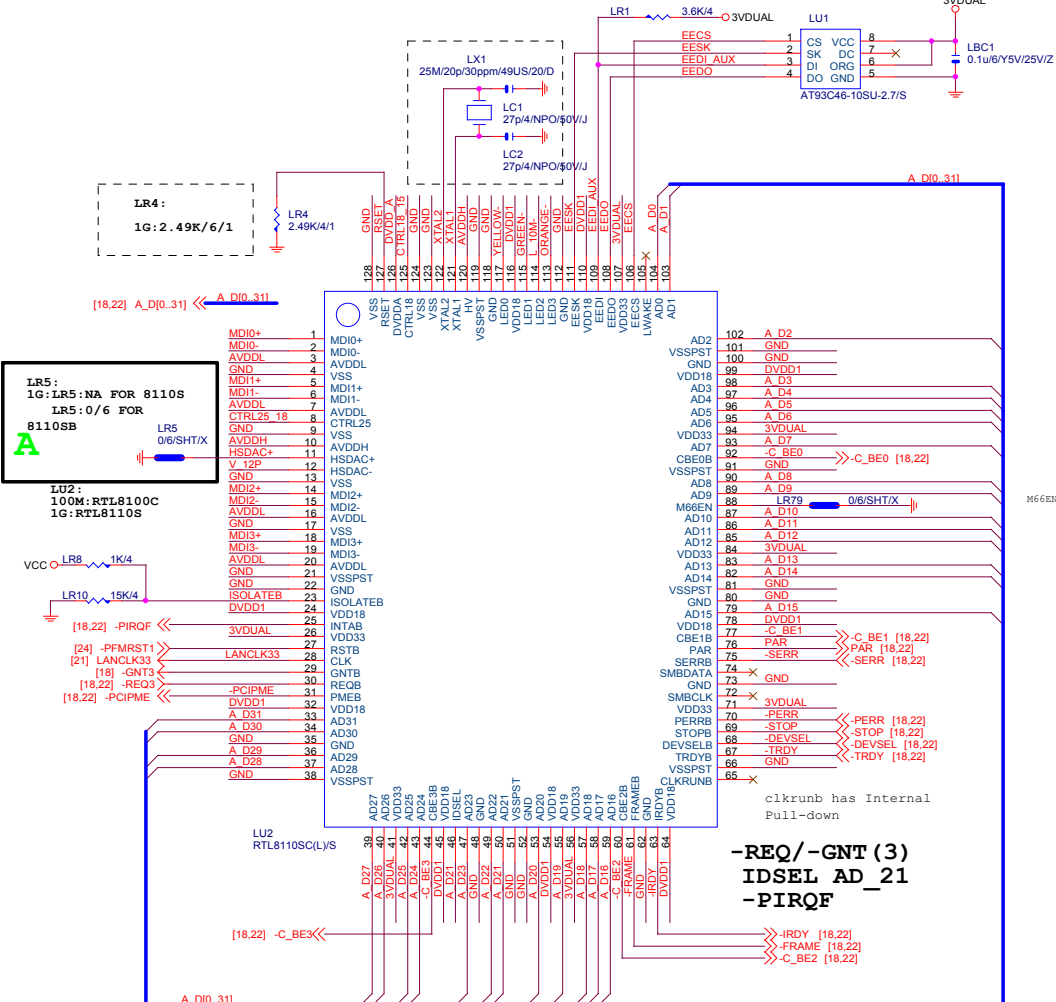

RTL8110S		Dual Color LED		
		Yellow	Green	Orange
LINK/SPEED	10Mb	ON		
	100Mb	ON	ON	
ACTIVE	10Mb		Blink	
	100Mb		Blink	ON

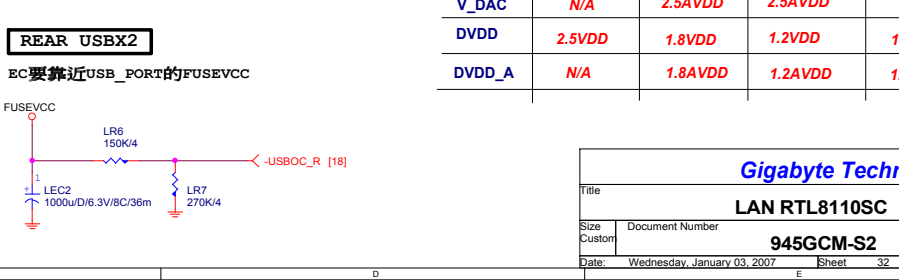
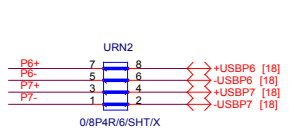
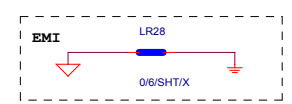

	RTL8100C	RTL8110S/ RTL8169S	RTL8110SB/ RTL8169SB	RTL8110SC
AVDDH	N/A	3.3AVDD	3.3AVDD	3.3AVDD
V_12P	2.5AVDD	N/A	3.3AVDD	3.3AVDD
AVDDL	3.3AVDD	2.5AVDD	2.5AVDD	1.8AVDD
V_DAC	N/A	2.5AVDD	2.5AVDD	N/A
DVDD	2.5VDD	1.8VDD	1.2VDD	1.5VDD
DVDD_A	N/A	1.8AVDD	1.2AVDD	1.5AVDD

CPU SMART FAN SMART FAN

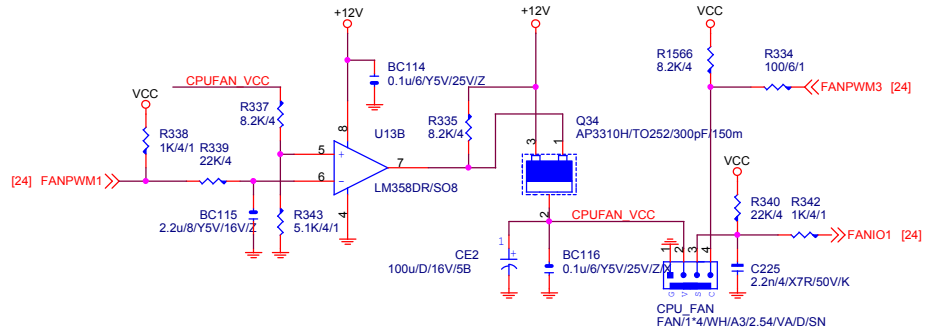

PROCESSOR HOT

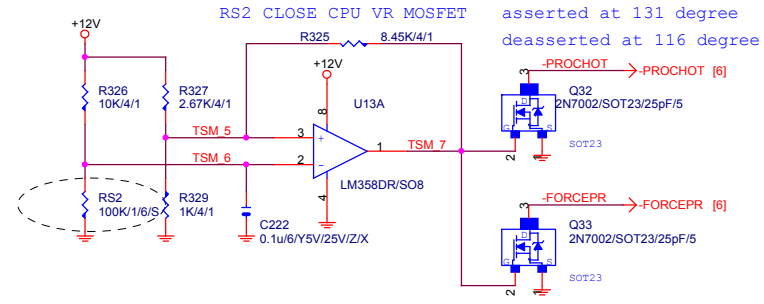

INTEL FRONT PANEL

MPD- : (GPIO25--VCCSUS3+HI+HI+DEFINED (C3/C4/S/1/S3/S/4/S5)) -->INTEL

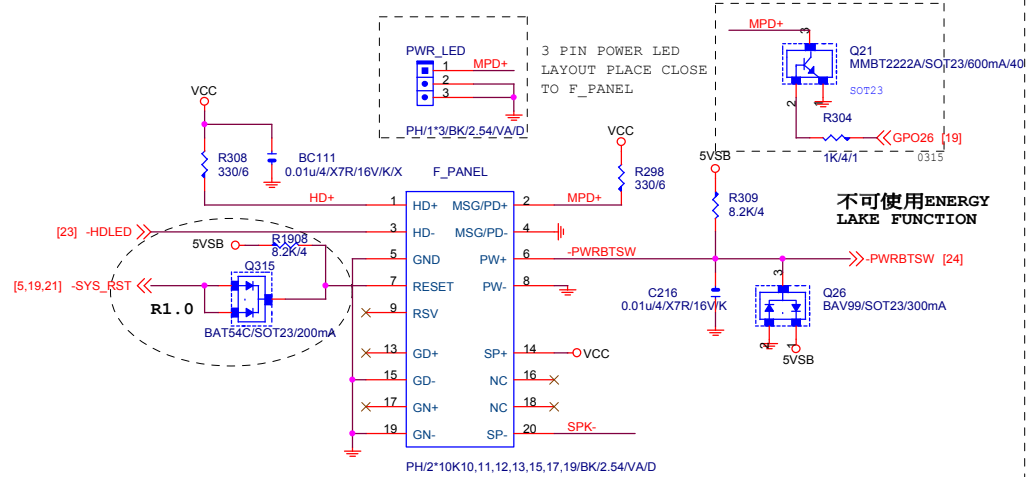

SYS_FAN

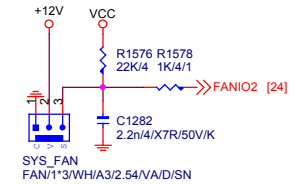

BUZZER

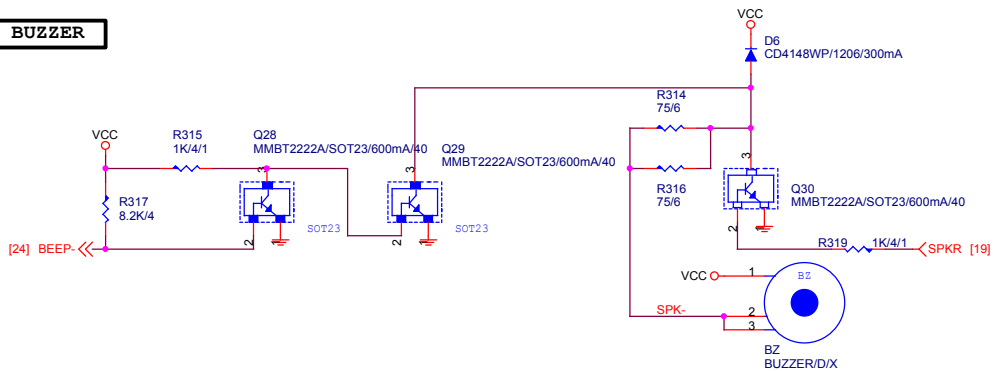

Gigabyte Technology		
FRONT PANEL		
945GCM-S2		
Size Custom	Document Number	Rev 3.0
Date: Wednesday, January 03, 2007	Sheet 33 of 33	