

Version	Date	Author	Change Note	Approved
V1.0	20101207	HCH	First edictor	
V1.1	20110516	BrookWang	1) Change U45:AK8973 to AK8975 (BGA-package) 2) Power sequence circuit change include HDMI etc. 3) Camera circuit: connect a resistor R40[10R] in series with NET[VIP_CLKIN]. 4) DC circuit: add a decoupling capacitor R256[22uF/16V] to reduce power ripple.	Luoxh
V1.2	20110622	BrookWang	1) Change LED TP_VCC NET conection to VB. 2) [DCN] Change component Q16(3904) type with XP151 PMOS,and add a pull-down resitance R256(20K) with GND, to make sure AP3911 to be fully off 3) [DCN] Change componenent C199 C201 C272 PCB decal with C0603 to ensure real value 4) [DCN] Change componenent D10(1SS400) with CAP 1uF	Luoxh

- 1.I2C0 IC
- 2.I2C1 IO
- 3.UART1
- 4.IO
- 5.GP#0 RK2900 IO

Title: MSI1003HC	
File: Modify note	REV: 1.2
Create Date:	Page Num:
Modify Date: Wednesday, June 22, 2011	Page Total:

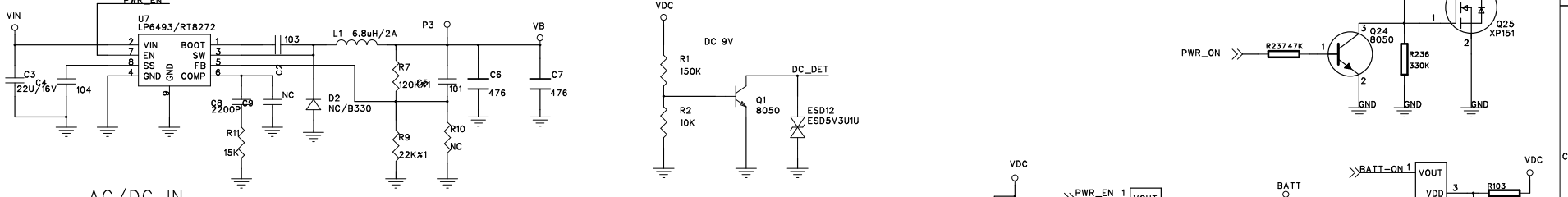
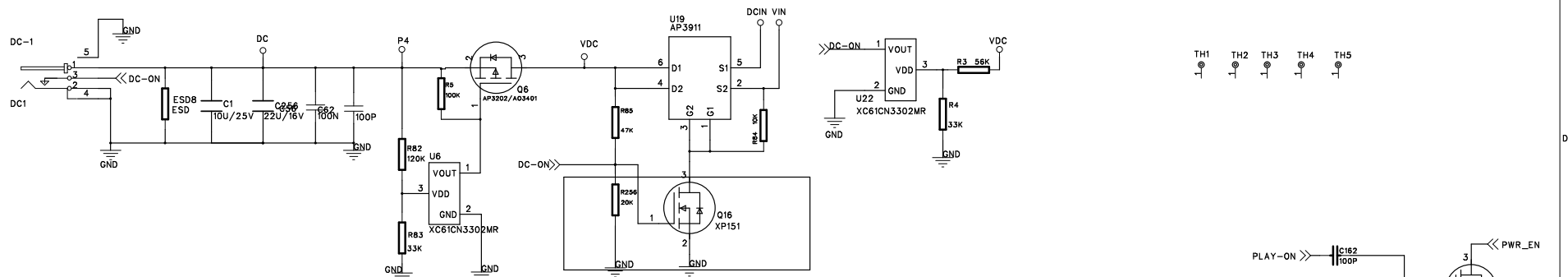

AC/DC IN

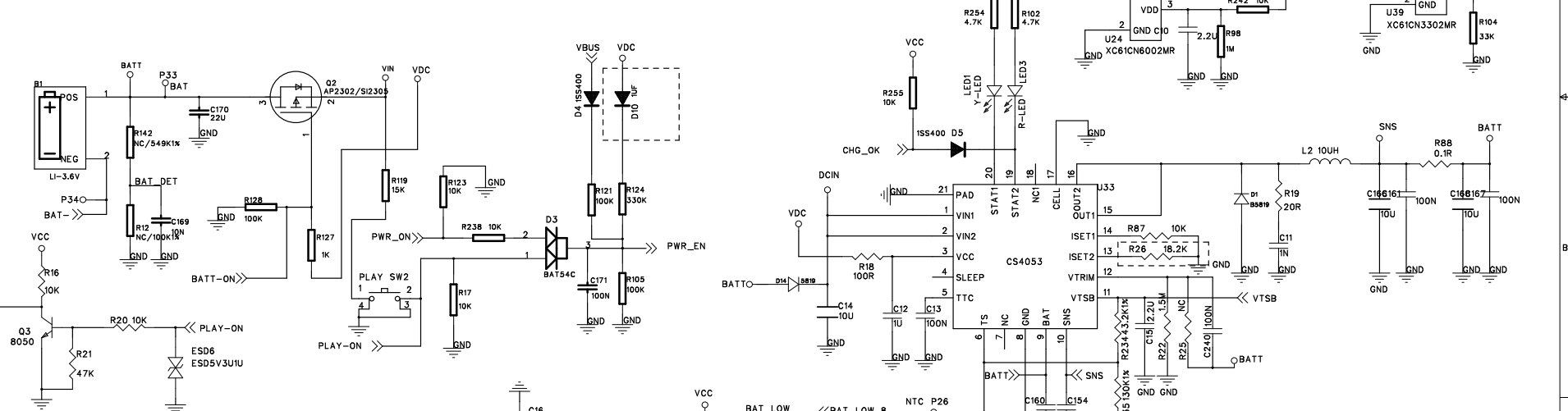

BATTERY DET

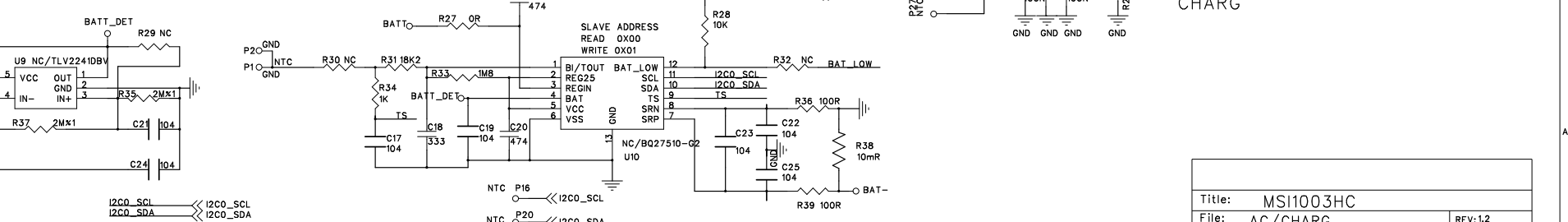

CHARGE



Title: MS1003HC	
File: AC/CHARGE	REV:1.2
Create Date:	Page Num: 3
Modify Date: Wednesday, June 22, 2011	Page Total: 14

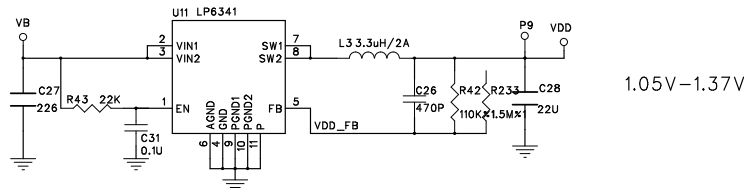

1.05V-1.37V

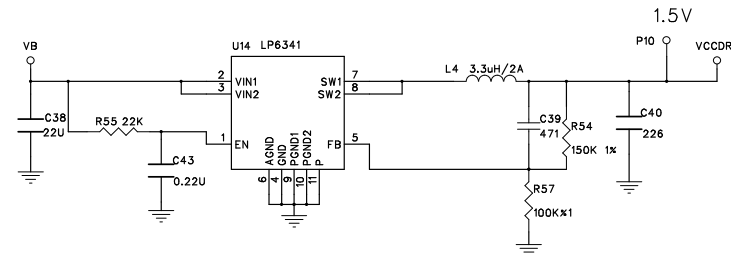
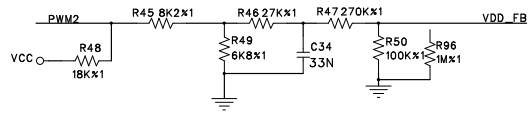

1.5V

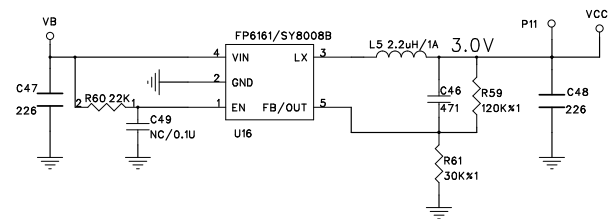

3.0V

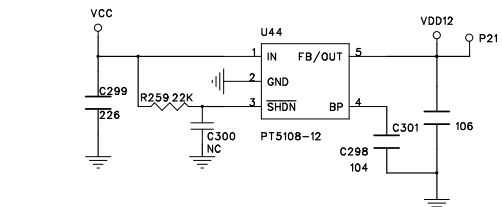
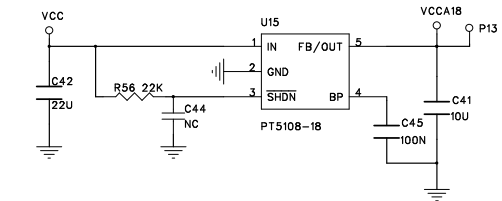
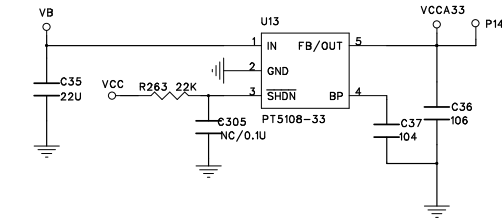
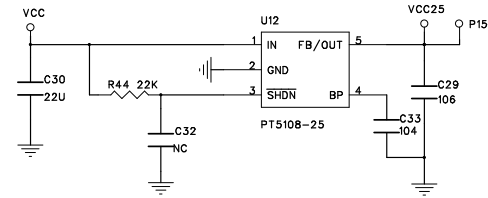

SYSTEM POWER

Title: MSI1003HC	
File: SYSTEM POWER	REV: 1.2
Create Date:	Page Num#
Modify Date@Wednesday, June 22, 2011	Page Total#

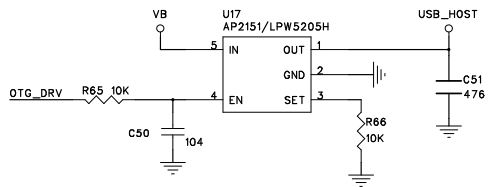

USB_INT >>> USB_INT 8
 UART1_SQOUT <<< UART1_SQOUT 8
 UART1_SIN <<< UART1_SIN 8

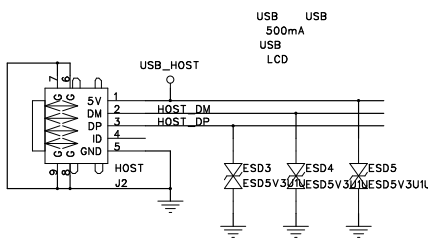
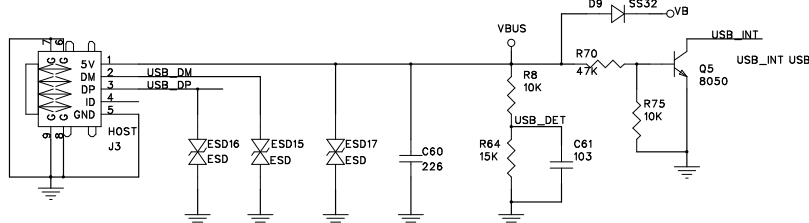

USB&HOST

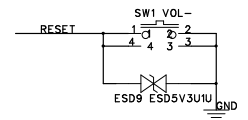
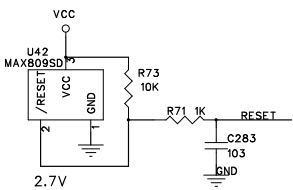

RESET

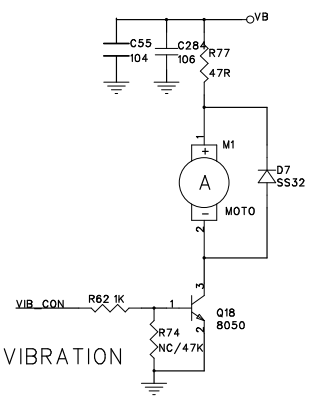

VIBRATION

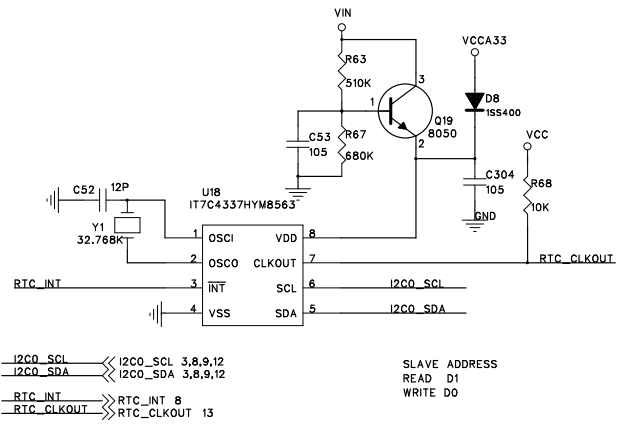

I2CO_SCL <<< I2CO_SCL 3,8,9,12
 I2CO_SDA <<< I2CO_SDA 3,8,9,12
 RTC_INT <<< RTC_INT 8
 RTC_CLKOUT <<< RTC_CLKOUT 13

SLAVE ADDRESS
 READ D1
 WRITE D0

RTC

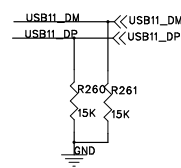
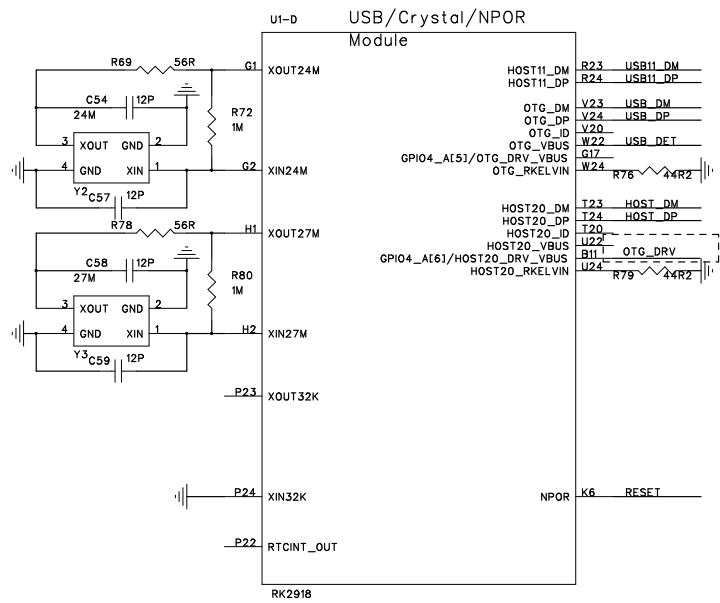

Title: MS1003HC	
File: USB_HOST/RTC/VIB	REV: 1.2
Create Date:	Page Num:
Modify Date@Wednesday, June 22, 2011	Page Totd#

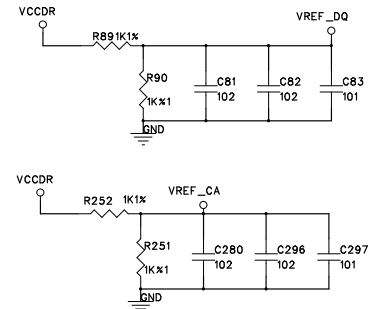
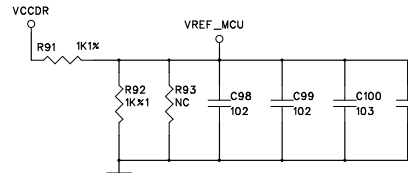
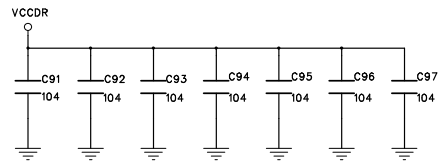
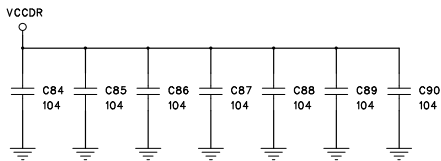
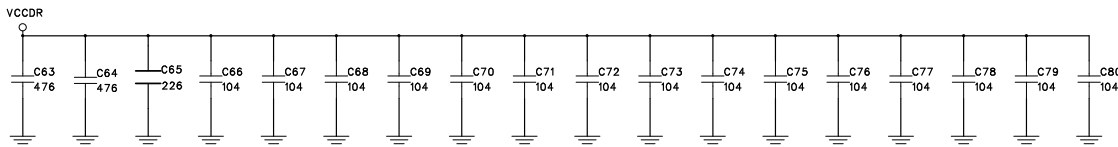
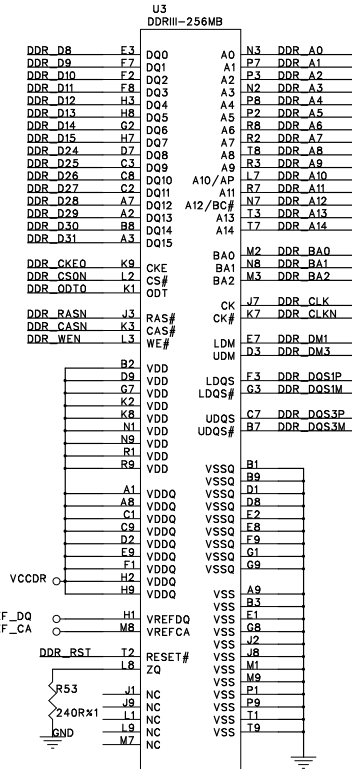
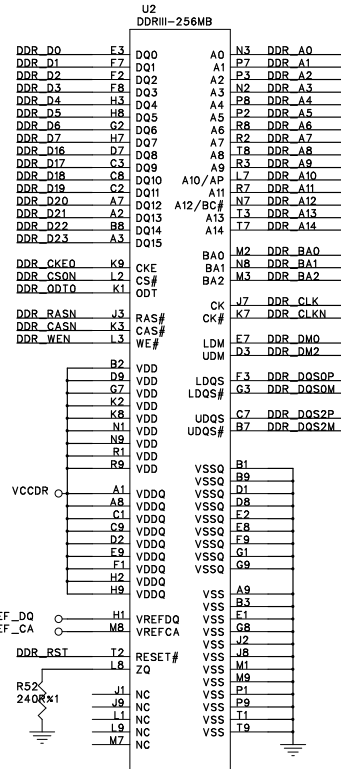
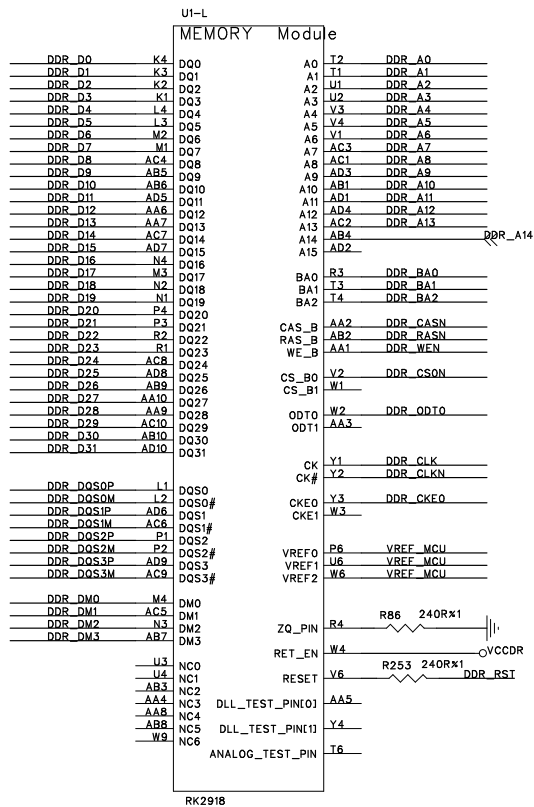

Title: MS1003HC		
File: DDRII	REV: 1.2	
Create Date:	Page	Nur#:
Modify Date: Wednesday, June 22, 2011	Page Tot#	

DDRII

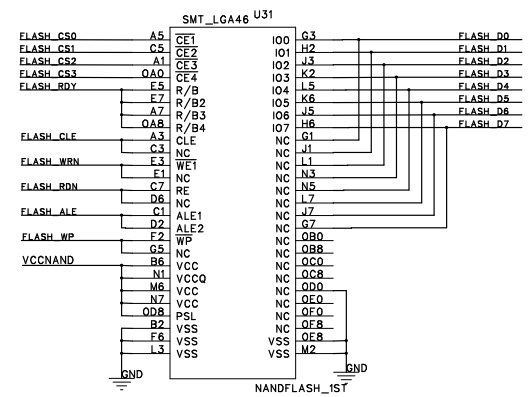
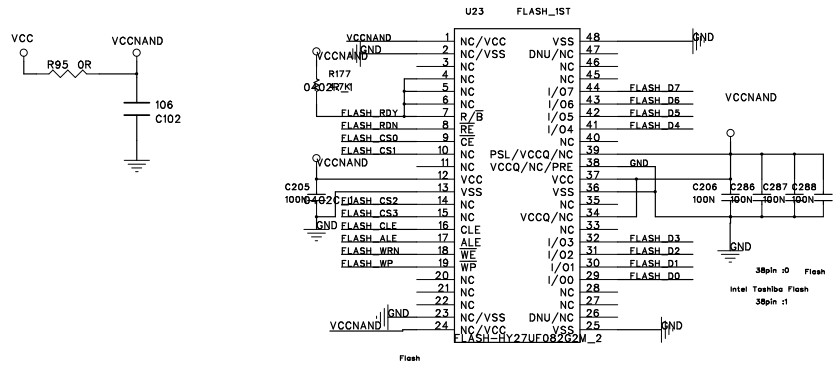

FLASH

NAND FLASH/EMMC

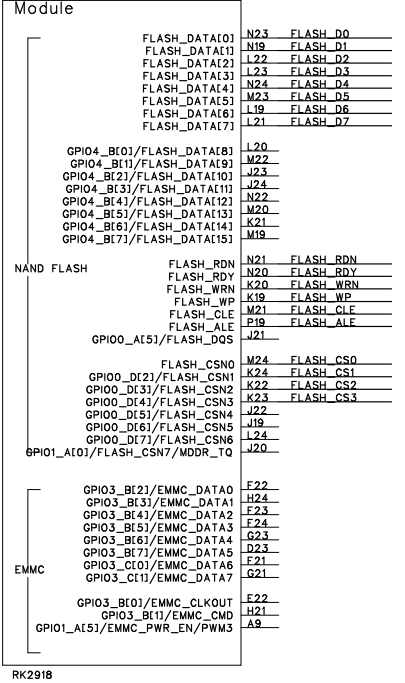

SDMMC Module

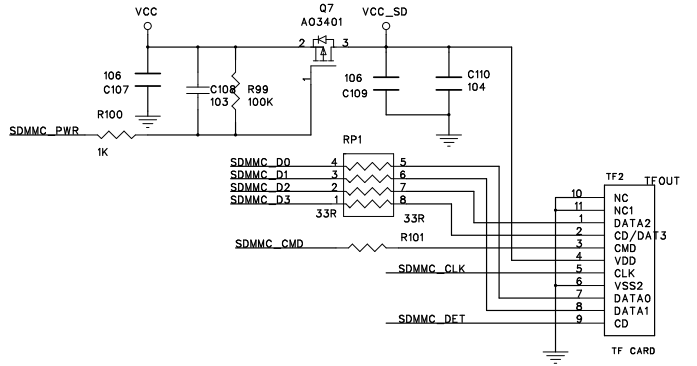
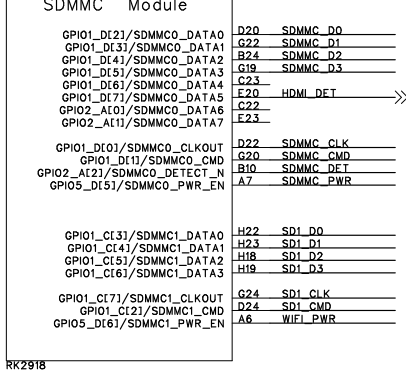

Title: MSI1003HC	
File: MEMORY	REV: 1.2
Create Date:	Page Num#
Modify Date@ednesday, June 22, 2011	Page Totd#

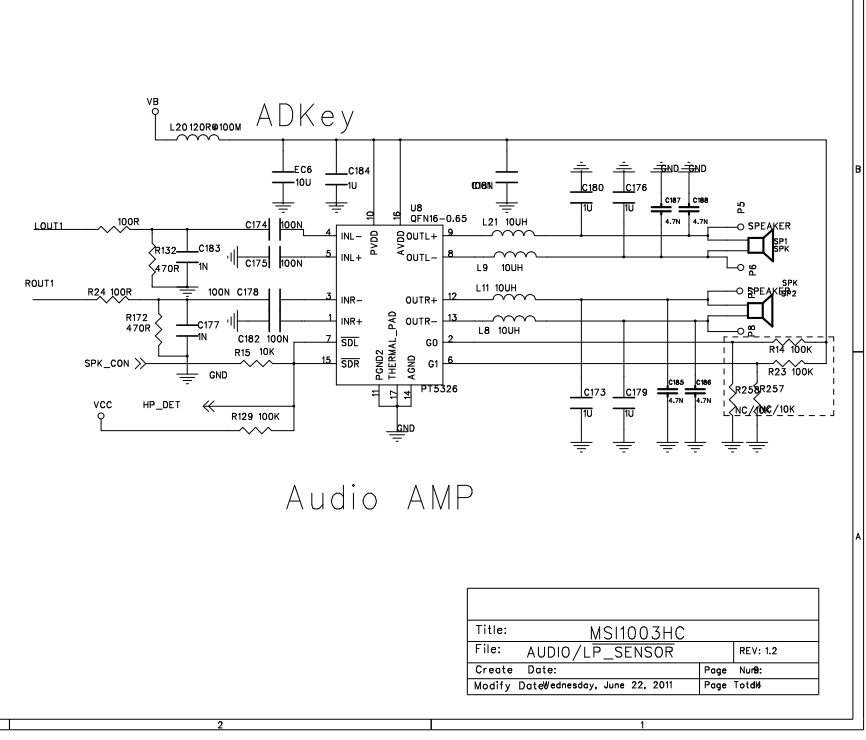
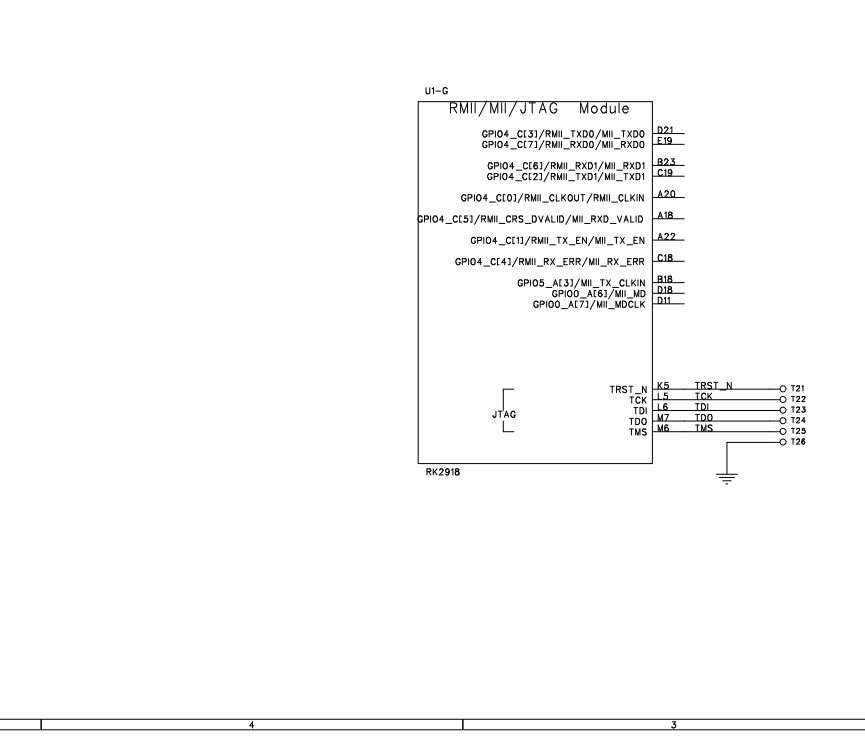
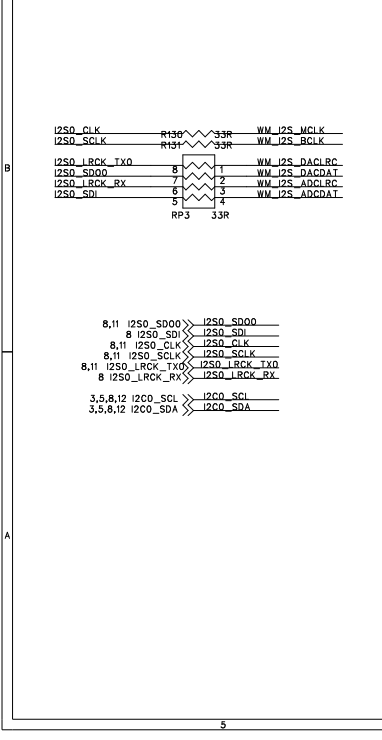
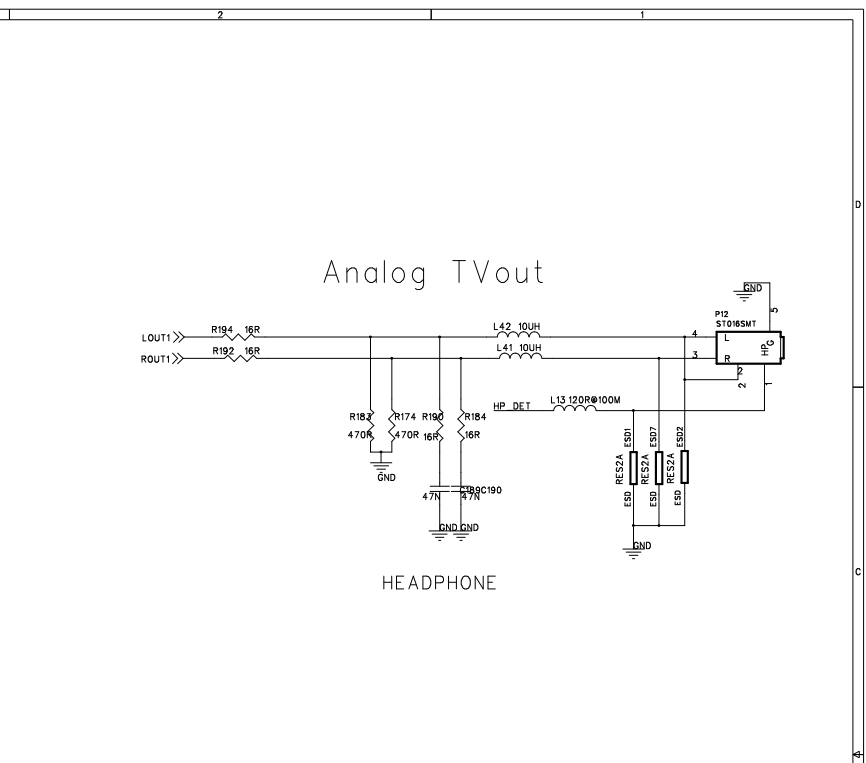
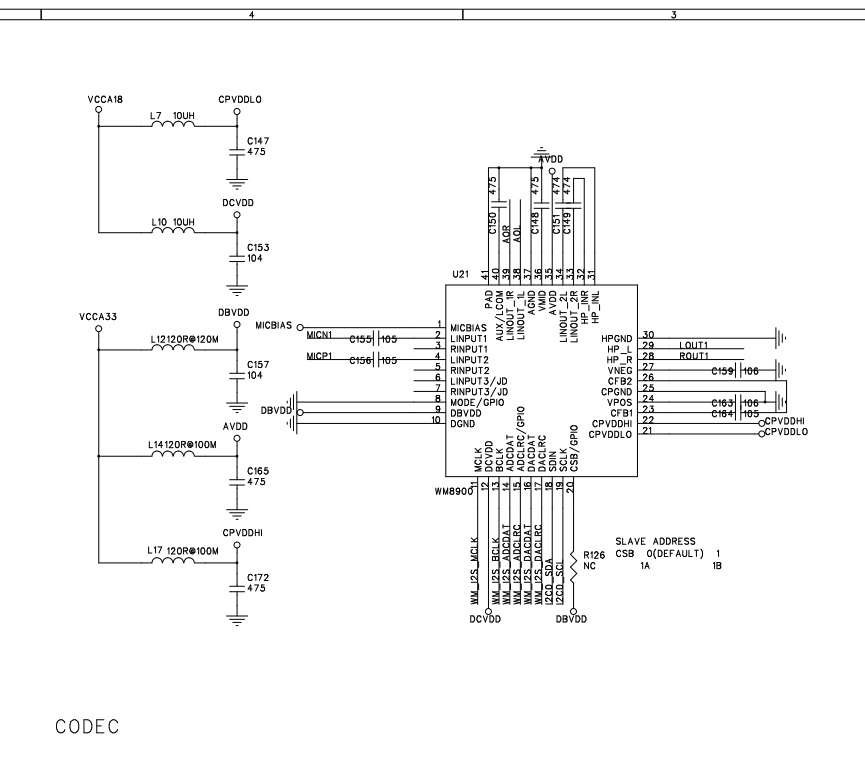
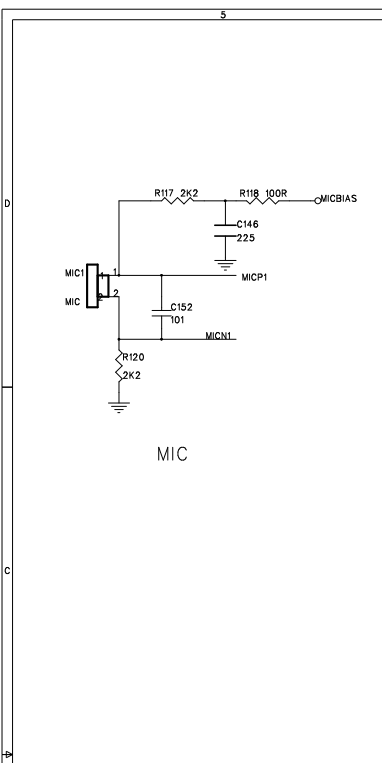

Title:	MSI1003HC	
File:	AUDIO/LP_SENSOR	REV: 1.2
Create Date:		Page Num:
Modify Date:	wednesday, June 22, 2011	Page Totl:

[DCN] VCC_TP , TP_VCC 5V

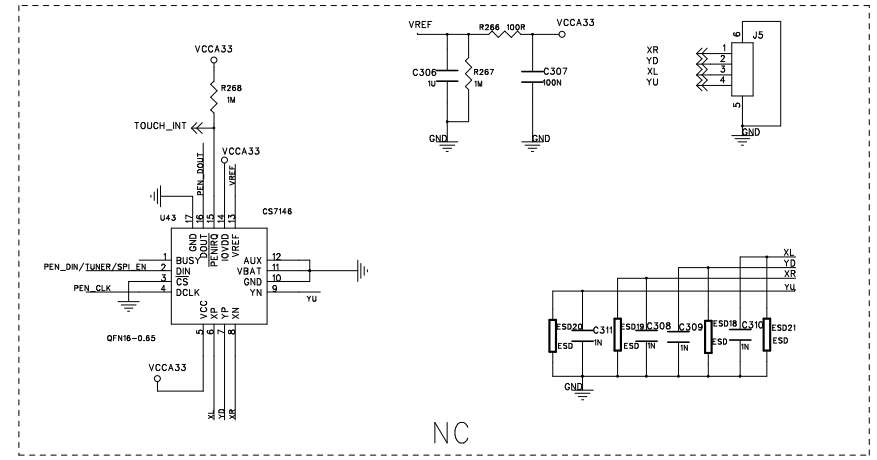
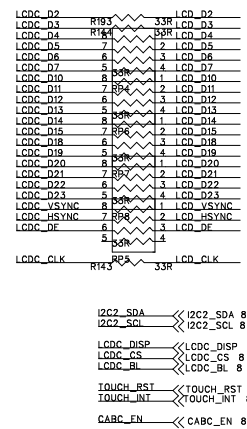
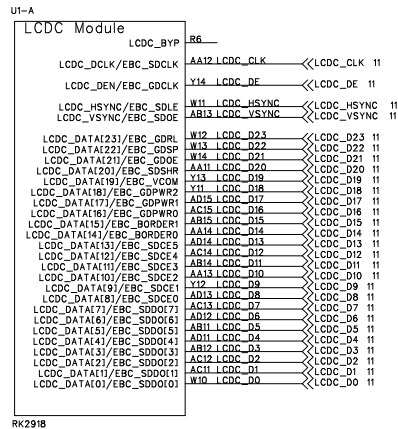
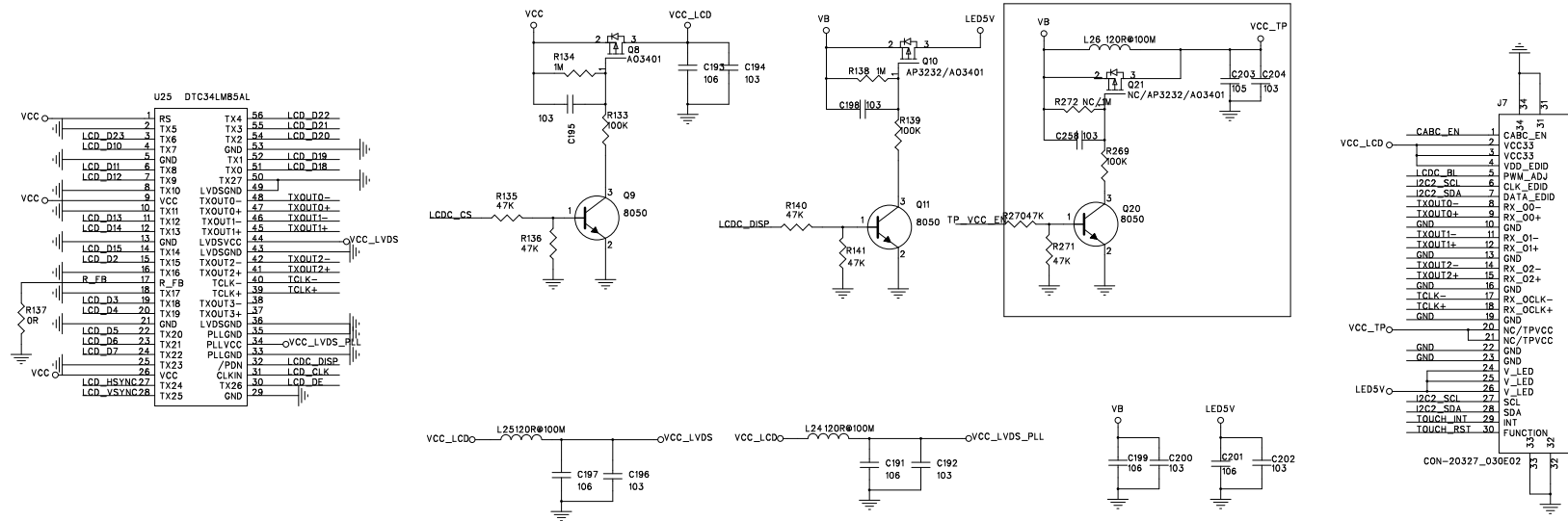

LCD CONNECTOR

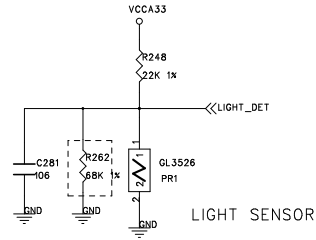

Title:	MS1003HC		
File:	LCD	REV:	1.2
Create Date:		Page	Num#
Modify Date:	Wednesday, June 22, 2011	Page	Total#

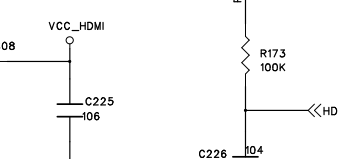
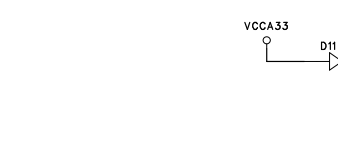
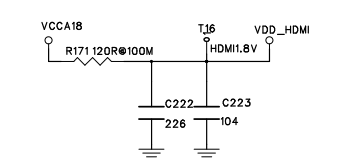
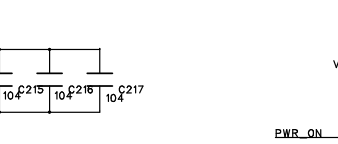
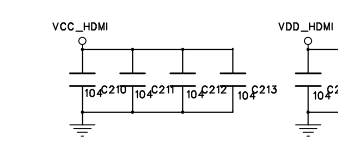
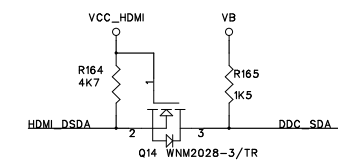
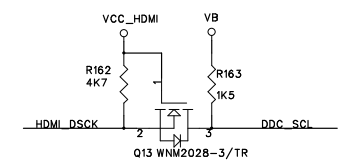
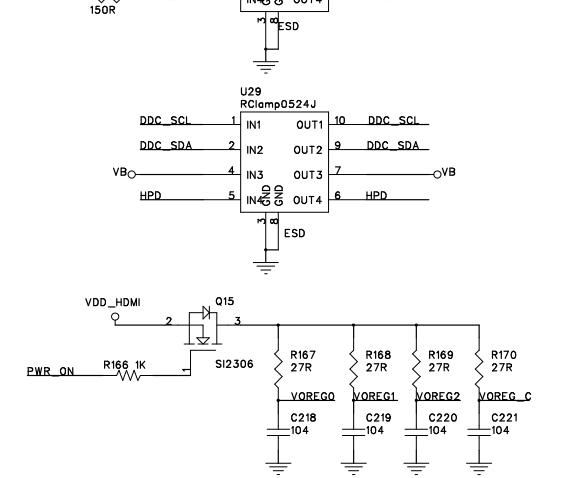
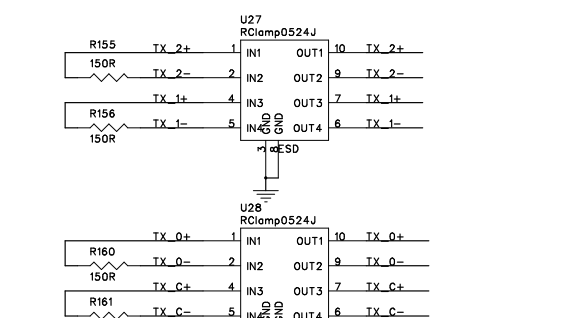
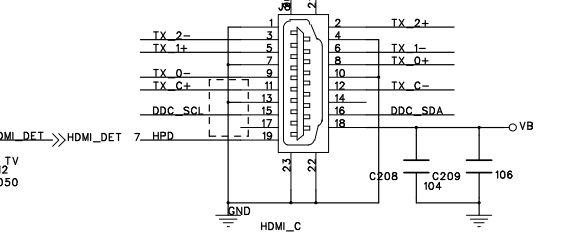
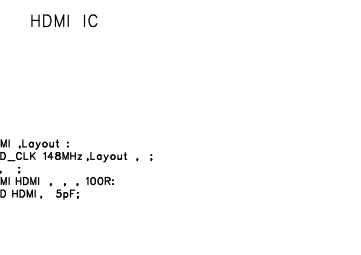
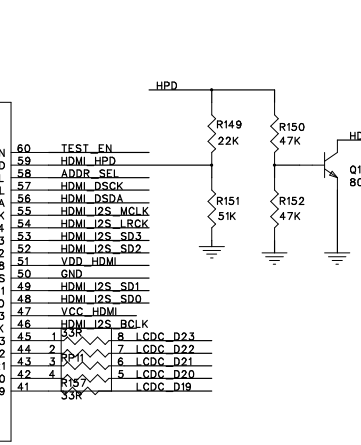
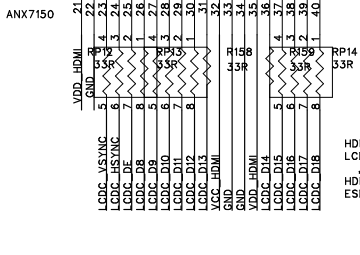
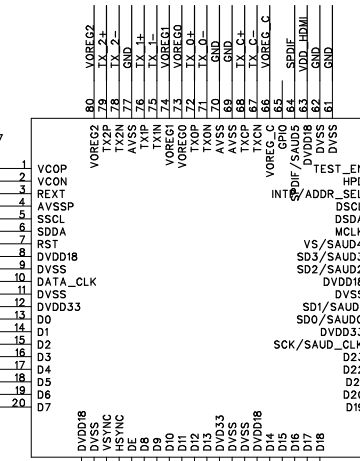
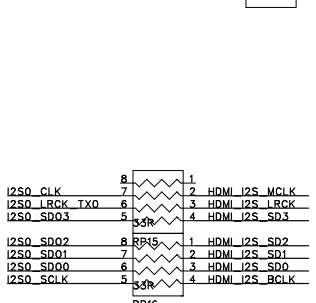
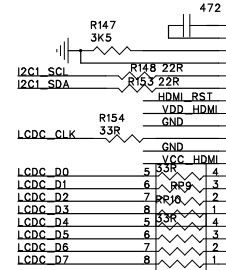
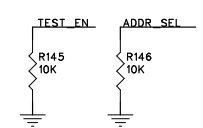
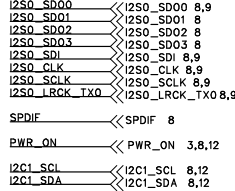
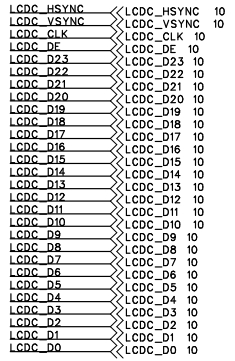

HDMI

Title: MS1003HC	
File: HDMI	REV: 1.2
Create Date:	Page Num#
Modify Date@Wednesday, June 22, 2011	Page Total#

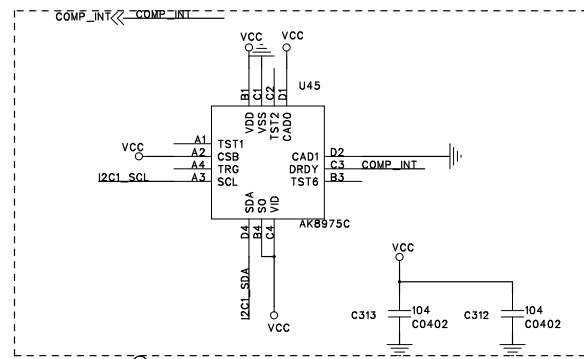
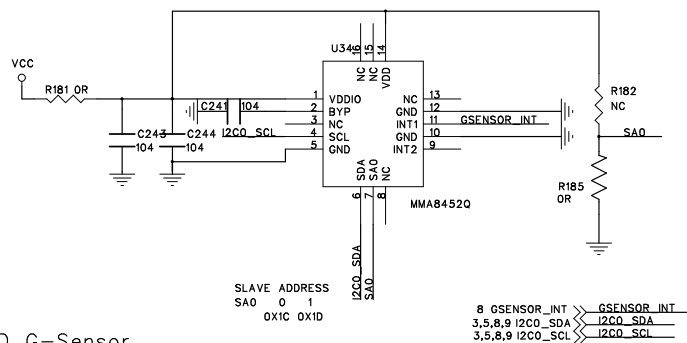
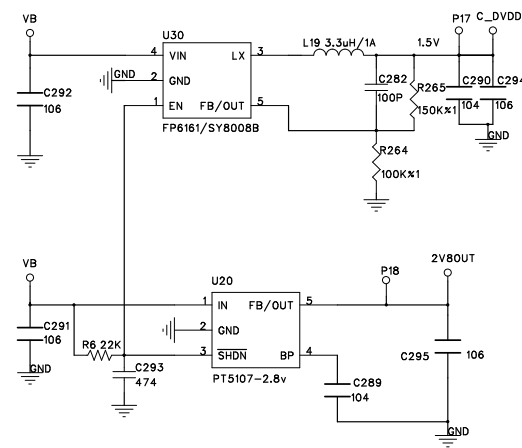
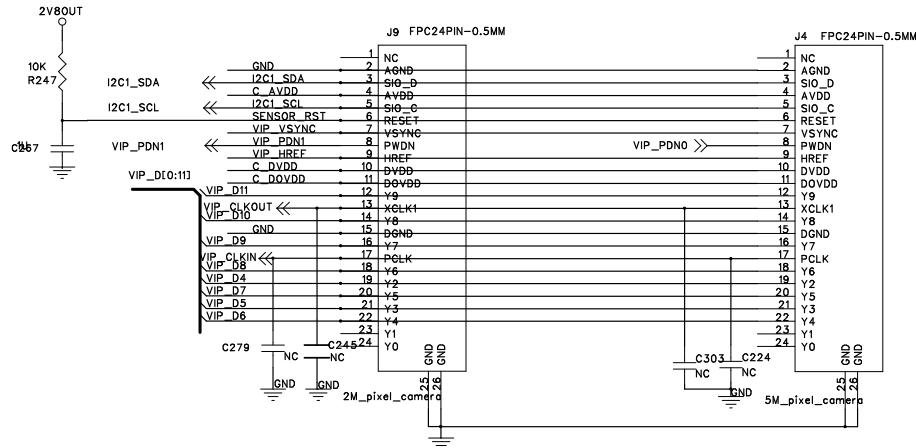
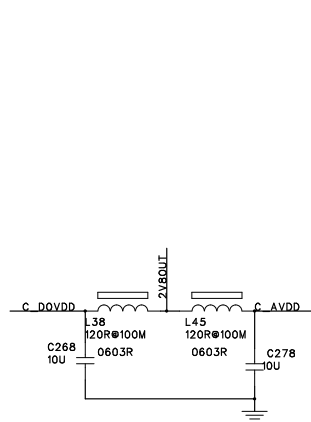

Compass

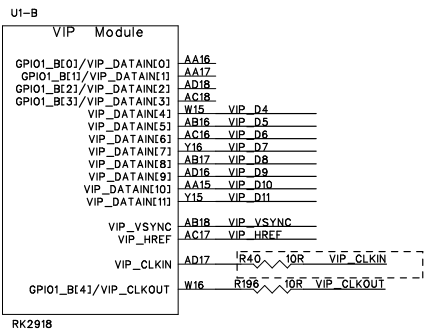

C245

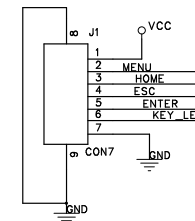
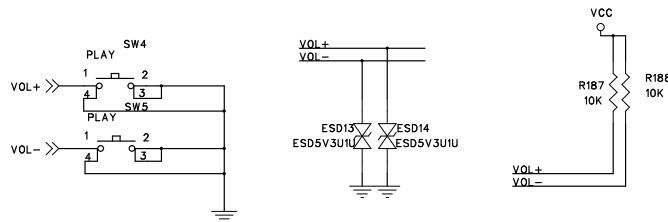

KEY BAORD

Title: MSI1003HC	
File: CAMERA/G_SENSOR/KEY/IR	REV:1:2
Create Date:	Page Num42
Modify Date@ednesday, June 22, 2011	Page Tot42

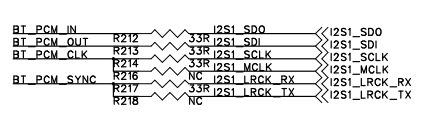
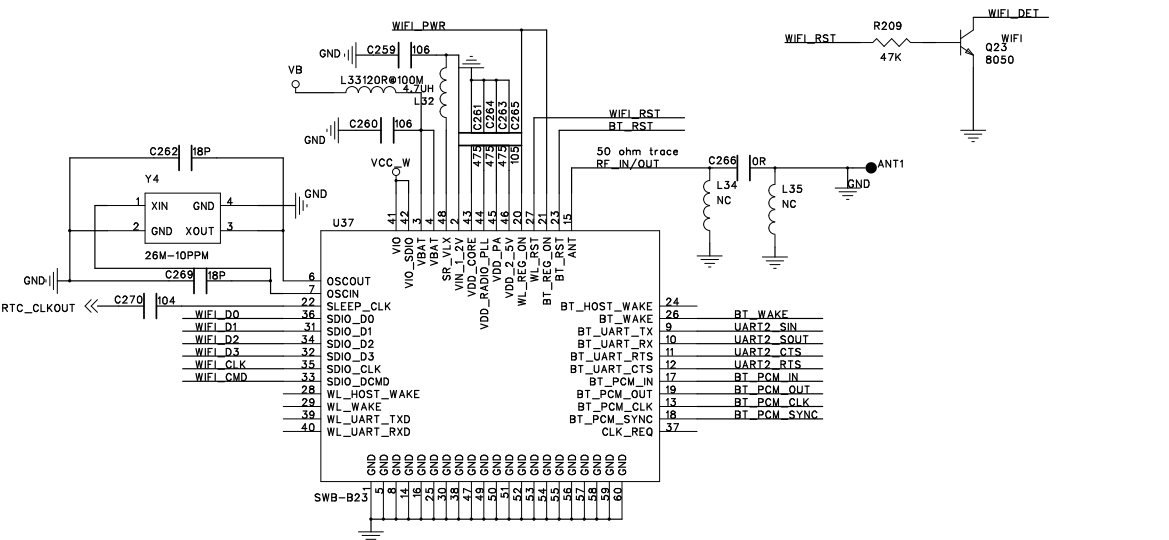
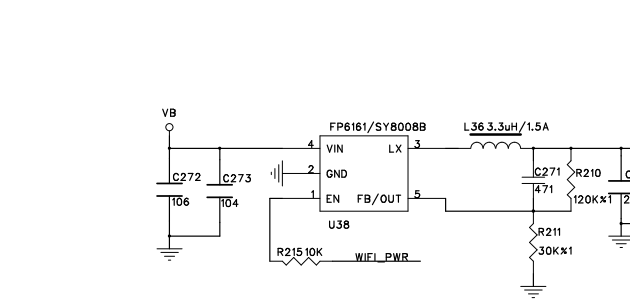
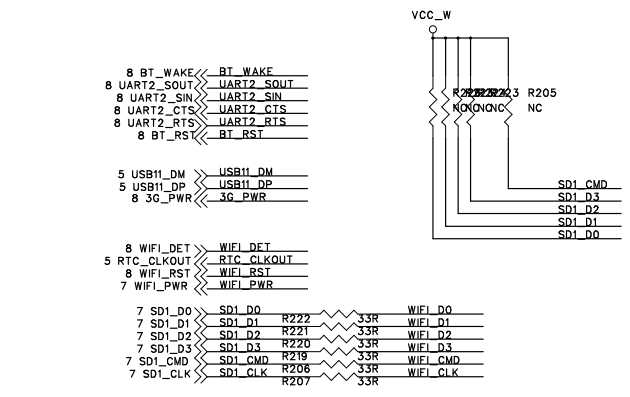
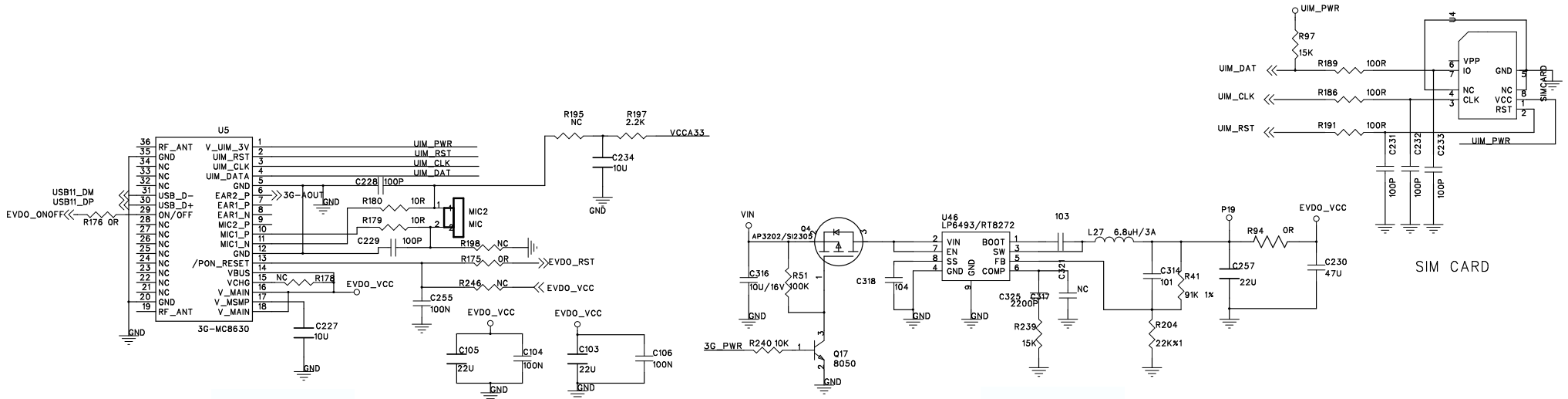

Title: MSI1003HC	
File: 3G/WIFI	REV: 1.2
Create Date:	Page Num33
Modify Date@ednesday, June 22, 2011	Page Total4

WIFI+BT

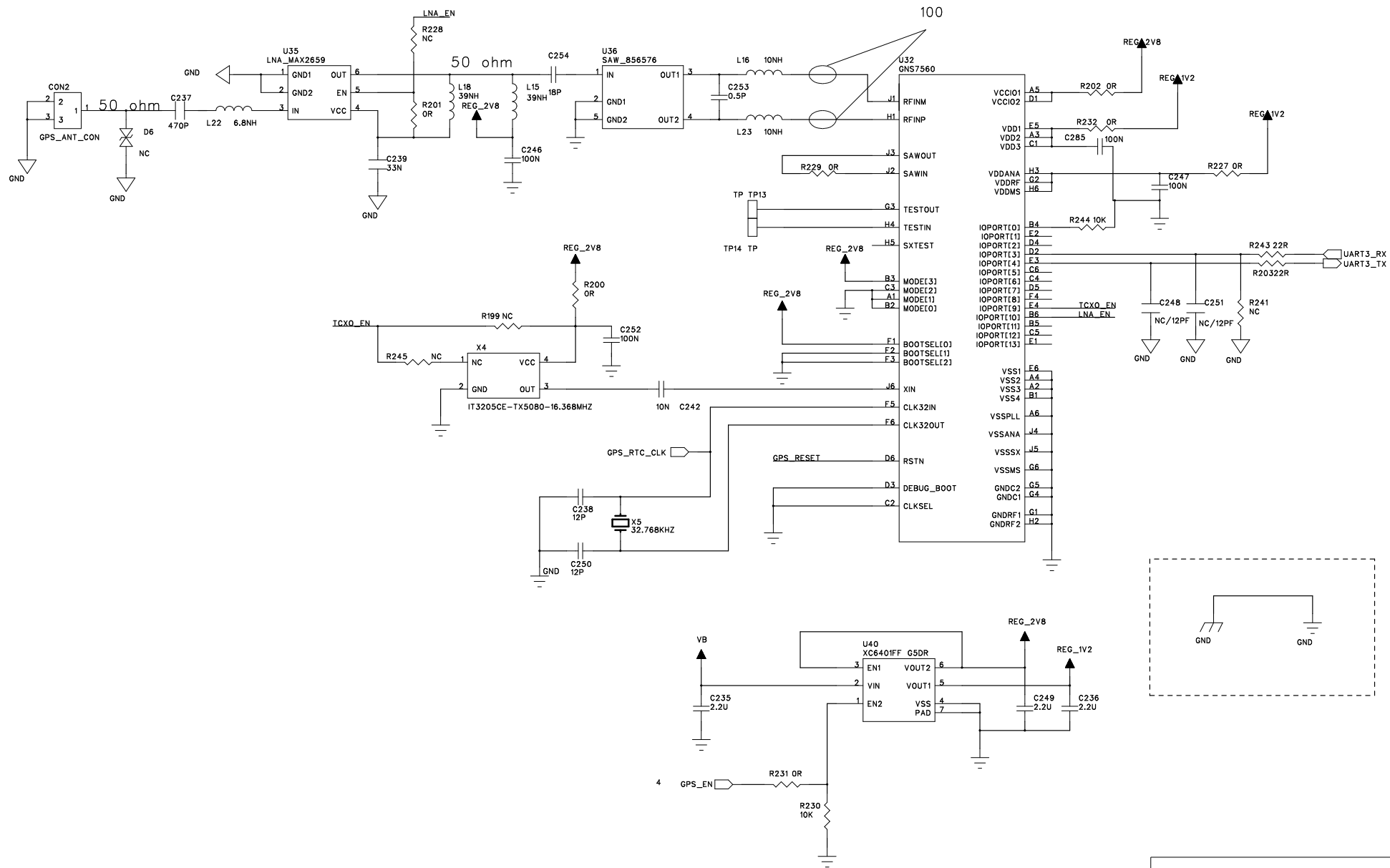

Title: MS11003HC	
File: GPS module	REV: 1.2
Create Date:	Page Num#4
Modify Date@Wednesday, June 22, 2011	Page Totol#4