

# Chelsea 10MG MP Build

2009.04.06

DRAWER	EE	DATE	POWER	DATE	<b>INVENTEC</b>
DESIGN					
CHECK					
RESPONSIBLE					
TITLE					<i>Chelsea 10MG</i>
SIZE =	3	VER :			SIZE
FILE NAME :	XXXX-XXXXXX-XX				CODE
P/N	XXXXXXXXXXXX				A3 CS
					DOC. NUMBER
					Model No
					REV
					000
					SHEET
					1 OF 70

DATE	CHANGE NO.	REV
1		2

**TABLE OF CONTENTS**

<b>PAGE</b>	<b>PAGE</b>	<b>PAGE</b>
<b>1.COVER PAGE</b>	<b>33- ICH9-1</b>	<b>55.WLAN /Debug</b>
<b>2.Index</b>	<b>34- ICH9-2</b>	<b>56.MDC CONN</b>
<b>3.Block Diagram</b>	<b>35- ICH9-3</b>	<b>57.LED &amp; MMB CONN</b>
<b>4.Power Sequence Block</b>	<b>36- ICH9-4</b>	<b>58. Fingerprinter Board</b>
<b>5-12.System Power</b>	<b>37- ICH9-5</b>	<b>59. FM Board</b>
<b>13.Clock Generator</b>	<b>38.SATA HDD &amp; SSD CONN</b>	<b>60.Kill Switch</b>
<b>14.CPU-1</b>	<b>39.ODD CONN</b>	<b>61.Screw</b>
<b>15.CPU-2</b>	<b>40.USB CONN</b>	<b>62.EMI</b>
<b>16.CPU-3</b>	<b>41.e-SATA CONN</b>	<b>63.3G/TV Tuner/GPS</b>
<b>17.CPU-4</b>	<b>42.Felica/Camera/Wirless LED</b>	<b>64.3D Sensor</b>
<b>18.Fan &amp; Thermal Sensor</b>	<b>43.Bluetooth CONN</b>	<b>65.FM differential to single end</b>
<b>19.Cantiga-1</b>	<b>44.KBC</b>	<b>66.Pick button board</b>
<b>20.Cantiga-2</b>	<b>45.K/B &amp; TP/B+Fingerprint &amp; K/B LED CONN</b>	<b>67.Touchpad switch board</b>
<b>21.Cantiga-3</b>	<b>46.Audio codec/Headphone+SPDIF CONN</b>	<b>68.LED &amp; Hall sensor board</b>
<b>22.Cantiga-4</b>	<b>47.Audio AMP/MIC/Speaker</b>	<b>69.Logo LED board</b>
<b>23.Cantiga-5</b>	<b>48. WUSB</b>	<b>70.Power button board</b>
<b>24.Cantiga-6</b>	<b>49.LAN Controller</b>	
<b>25.Cantiga-7</b>	<b>50.RJ45 &amp; Transformer</b>	
<b>26.DDR2 DIMM0</b>	<b>51.HDM CEC</b>	
<b>27.DDR2 DIMM1</b>	<b>52.HDMI CONN &amp; CIR</b>	
<b>28.DDR Damping</b>	<b>53.Card Reader/1394</b>	
<b>29.MXM CONN</b>	<b>54.Express Card CONN</b>	
<b>30.CRT CONN</b>		
<b>31.DisplayPort CONN</b>		
<b>32.LCM CONN</b>		

<b>INVENTEC</b>			
TITLE <i>Chelsea 10MG</i>			
SIZE <b>A3</b>	CODE <b>CS</b>	DOC. NUMBER <i>Model No</i>	REV <b>000</b>
CHANGE by <i>Drawer Name</i>		23-Dec-2008	
SHEET		<b>2</b>	OF <b>70</b>

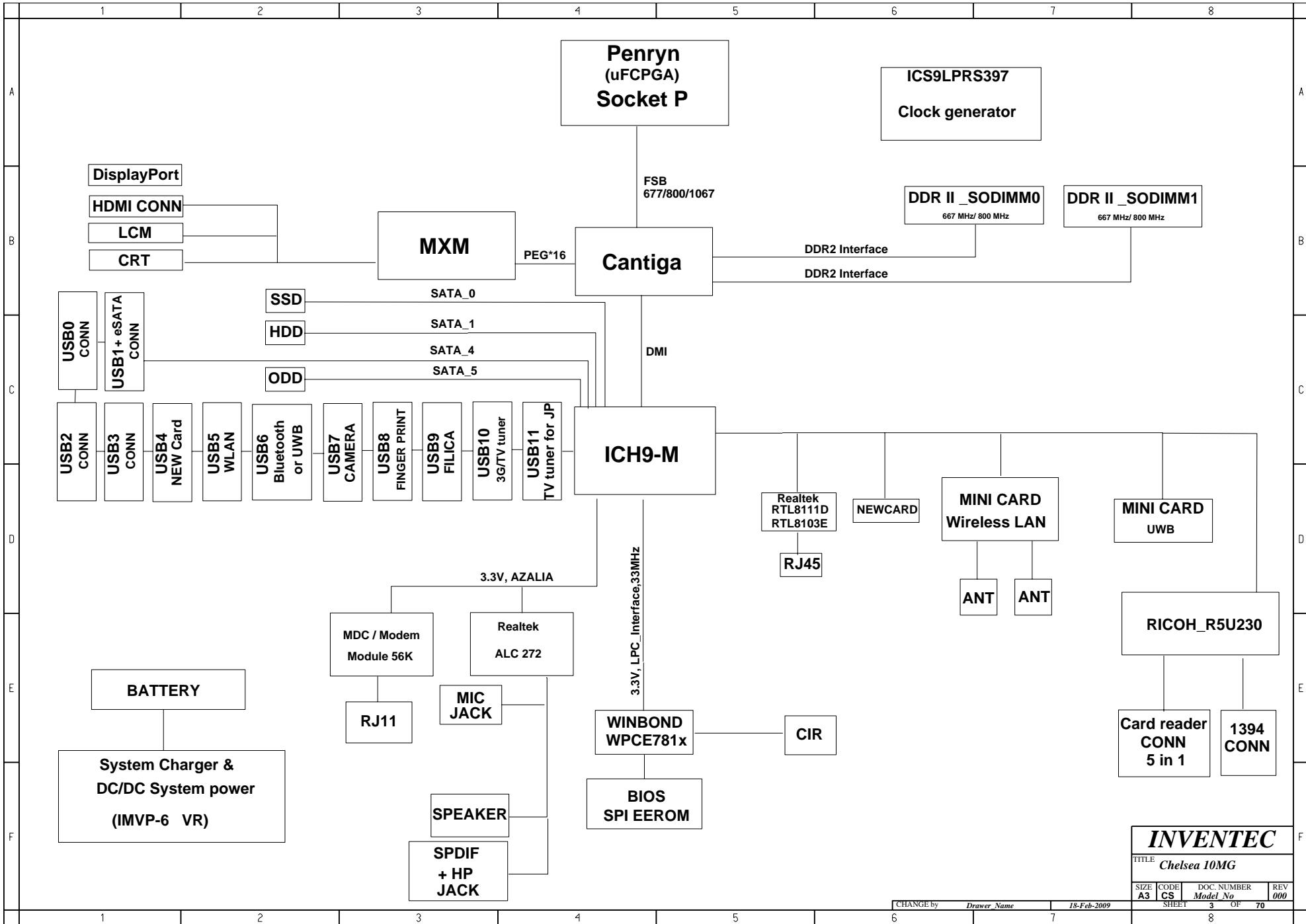

<b>INVENTEC</b>			
TITLE <i>Chelsea 10MG</i>			
SIZE <b>A3</b>	CODE <b>CS</b>	DOC. NUMBER <i>Model No</i>	REV <b>000</b>
SHEET <b>3</b>		OF <b>70</b>	

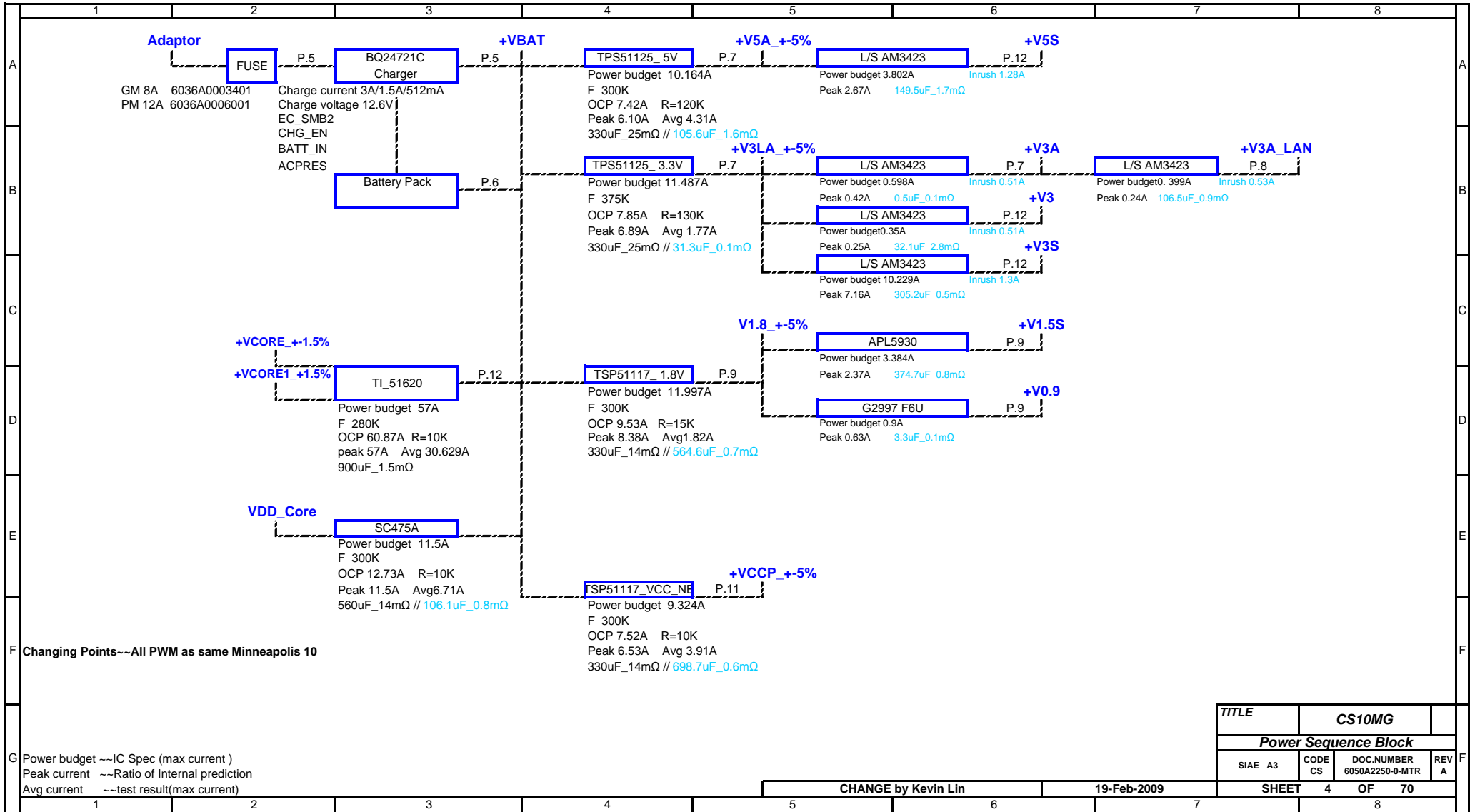

G Power budget --IC Spec (max current )  
 Peak current --Ratio of Internal prediction  
 Avg current --test result(max current)

TITLE		CS10MG	
Power Sequence Block			
SIAE A3	CODE CS	DOC.NUMBER 6050A2250-0-MTR	REV A
CHANGE by Kevin Lin		19-Feb-2009	
SHEET 4		OF 70	

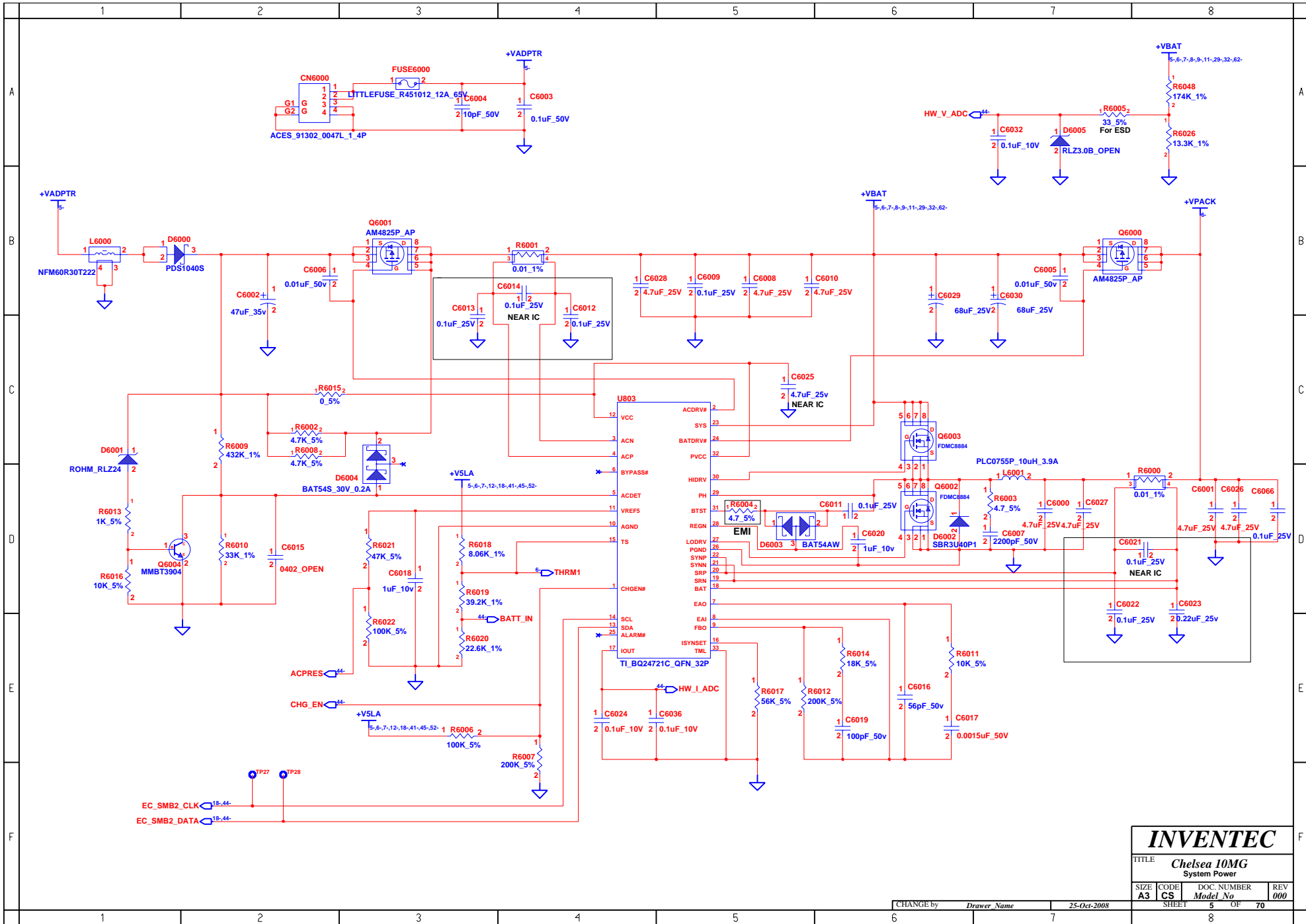

**INVENTEC**

TITLE *Chelsea 10MG*  
System Power

SIZE	CODE	DOC. NUMBER	REV
A3	CS	Model No	000

CHANGE by *Drawer Name* 25-Oct-2008 SHEET 5 OF 70

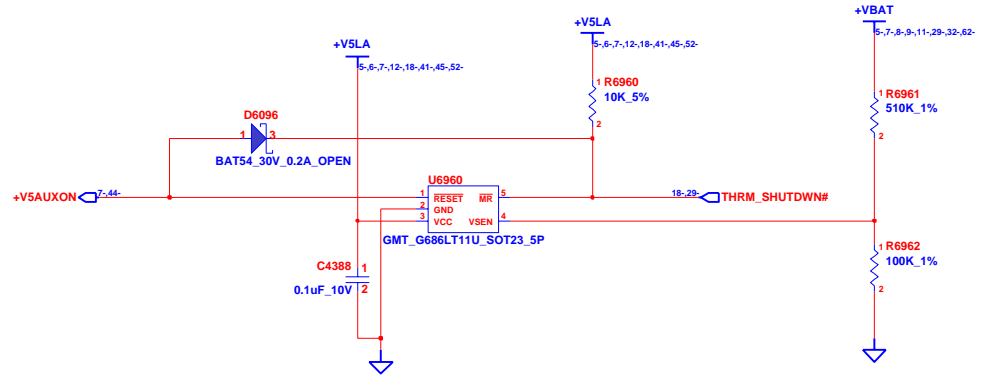
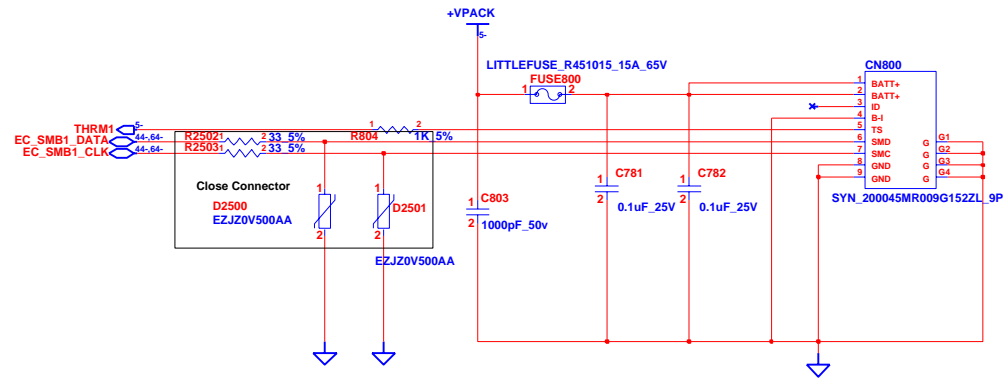

# INVENTEC

TITLE			
Chelsea 10MG			
System Power			
SIZE	CODE	DOC. NUMBER	REV
A3	CS	Model No	000

CHANGE by *Drawer Name* 25-Oct-2008

SHEET 6 OF 70

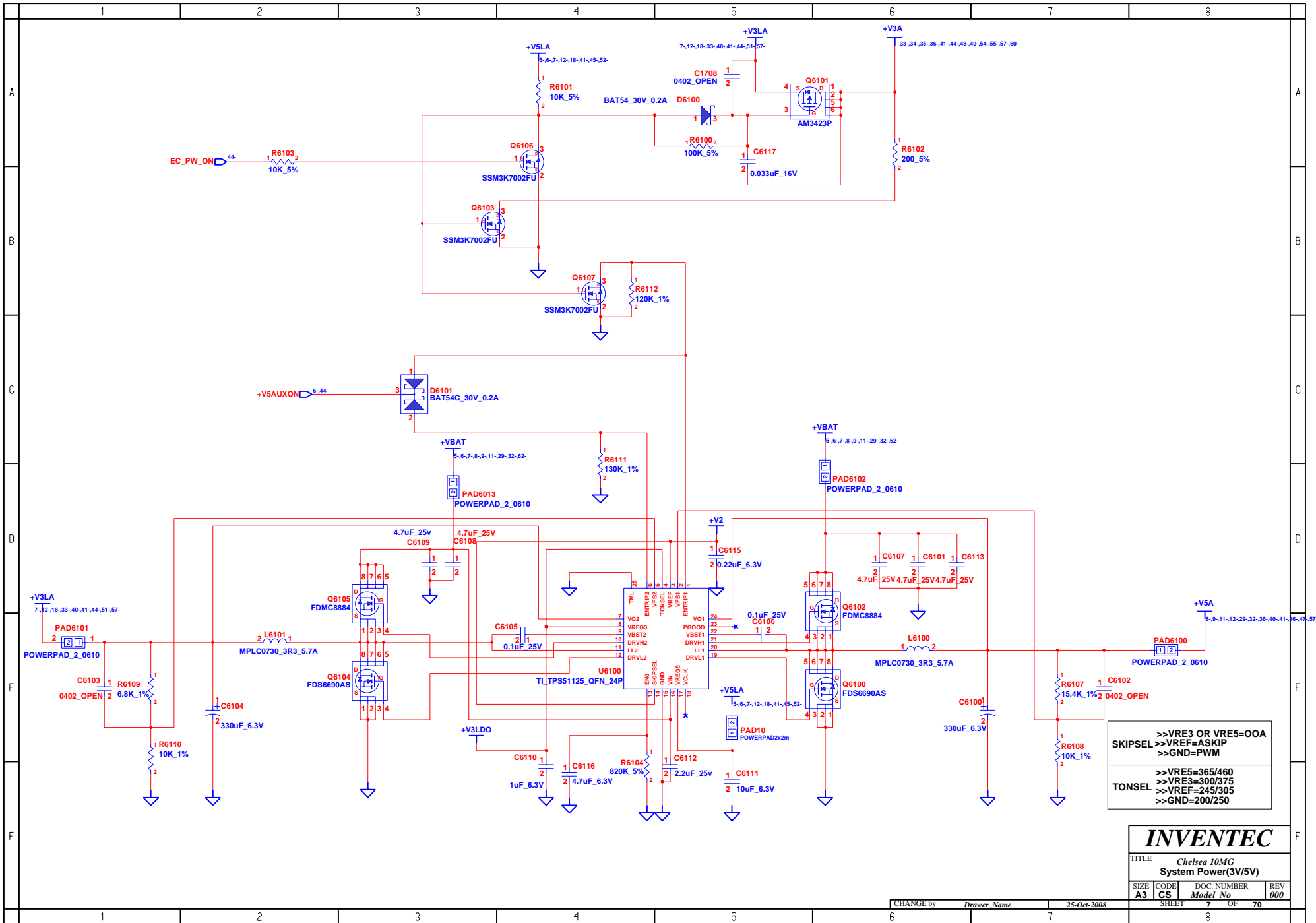

# INVENTEC

TITLE Chelsea 10MG System Power(3V/5V)			
SIZE A3	CODE CS	DOC. NUMBER Model No	REV 000

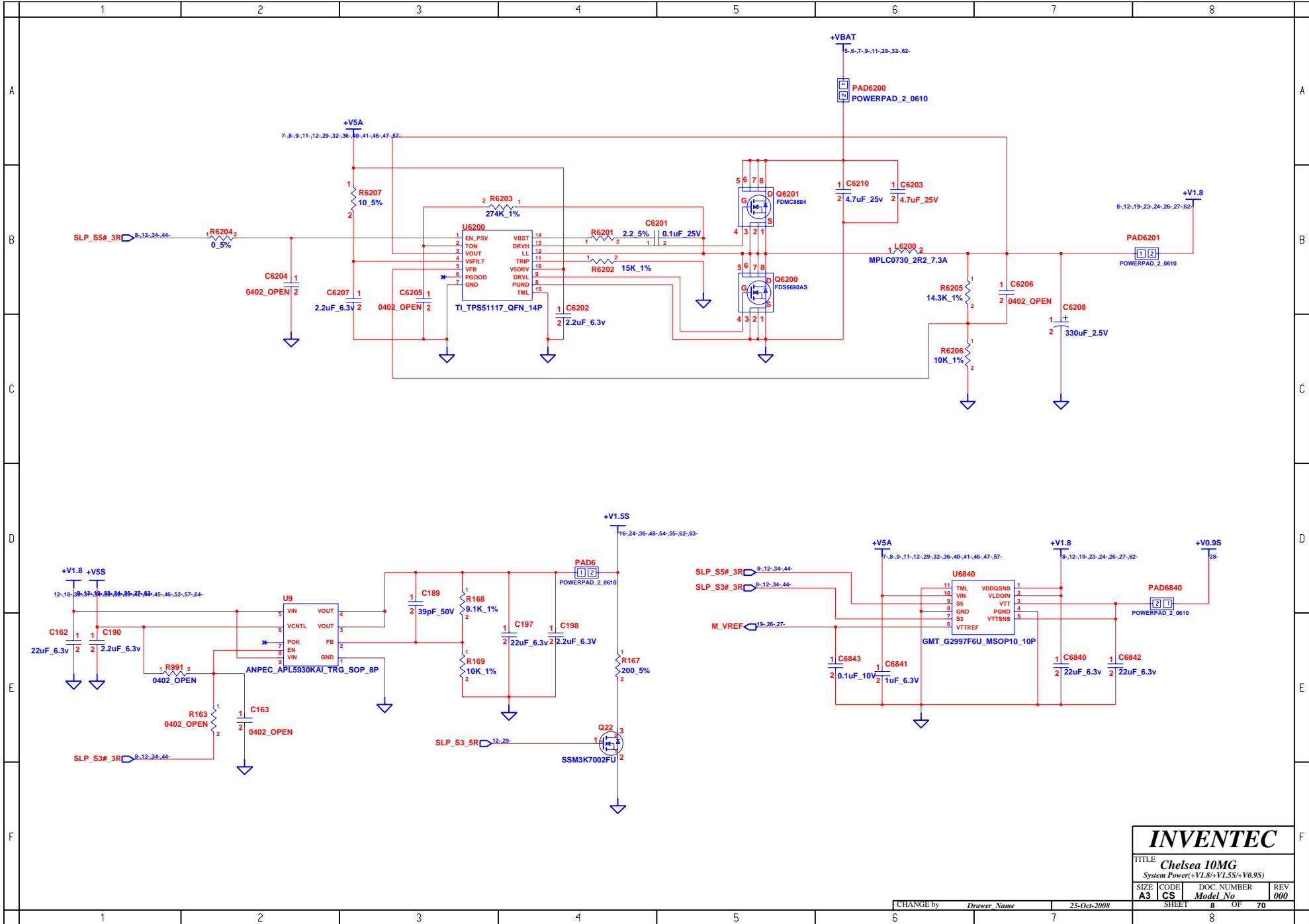

<b>INVENTEC</b>			
TITLE <b>Chelsea 10MG</b>			
System Power(+V1.8/+V1.5S/+V0.9S)			
SIZE <b>A3</b>	CODE <b>CS</b>	DOC. NUMBER <b>Model No</b>	REV <b>000</b>



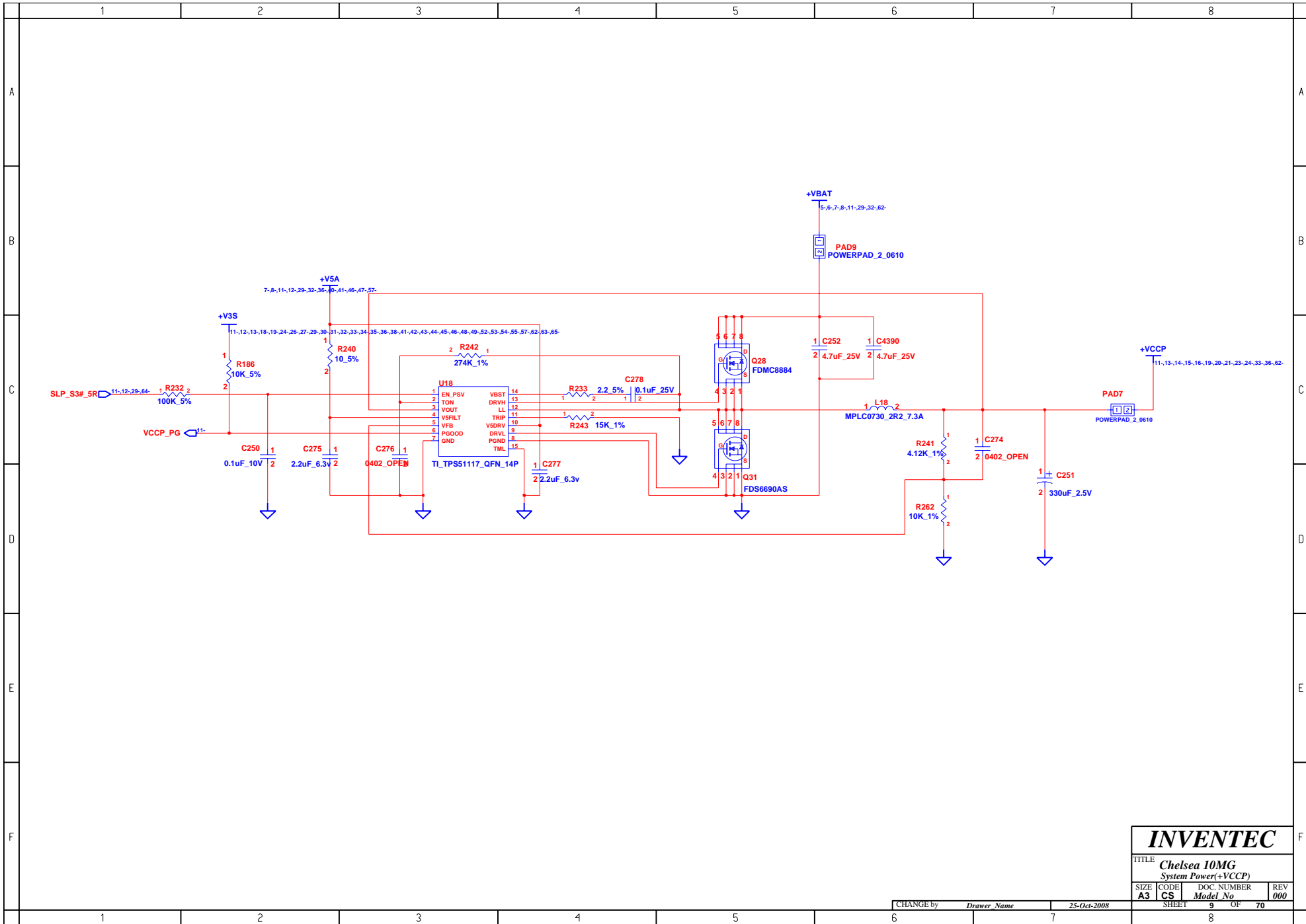

**INVENTEC**

TITLE  
**Chelsea 10MG**  
 System Power(+VCCP)

SIZE <b>A3</b>	CODE <b>CS</b>	DOC. NUMBER <i>Model No</i>	REV <b>000</b>
-------------------	-------------------	--------------------------------	-------------------

CHANGE by *Drawer Name* 25-Oct-2008 SHEET **9** OF **70**

**BLANK**

	1	2	3	4	5	6	7	8	
A									A
B									B
C									C
D									D
E									E
F									F
	1	2	3	4	5	6	7	8	

<b>INVENTEC</b>			
TITLE <i>Chelsea 10MG System Power(Blank)</i>			
SIZE	CODE	DOC. NUMBER	REV
A3	CS	Model No	000
CHANGE by <i>Drawer Name</i>		25-Oct-2008	SHEET 10 OF 70

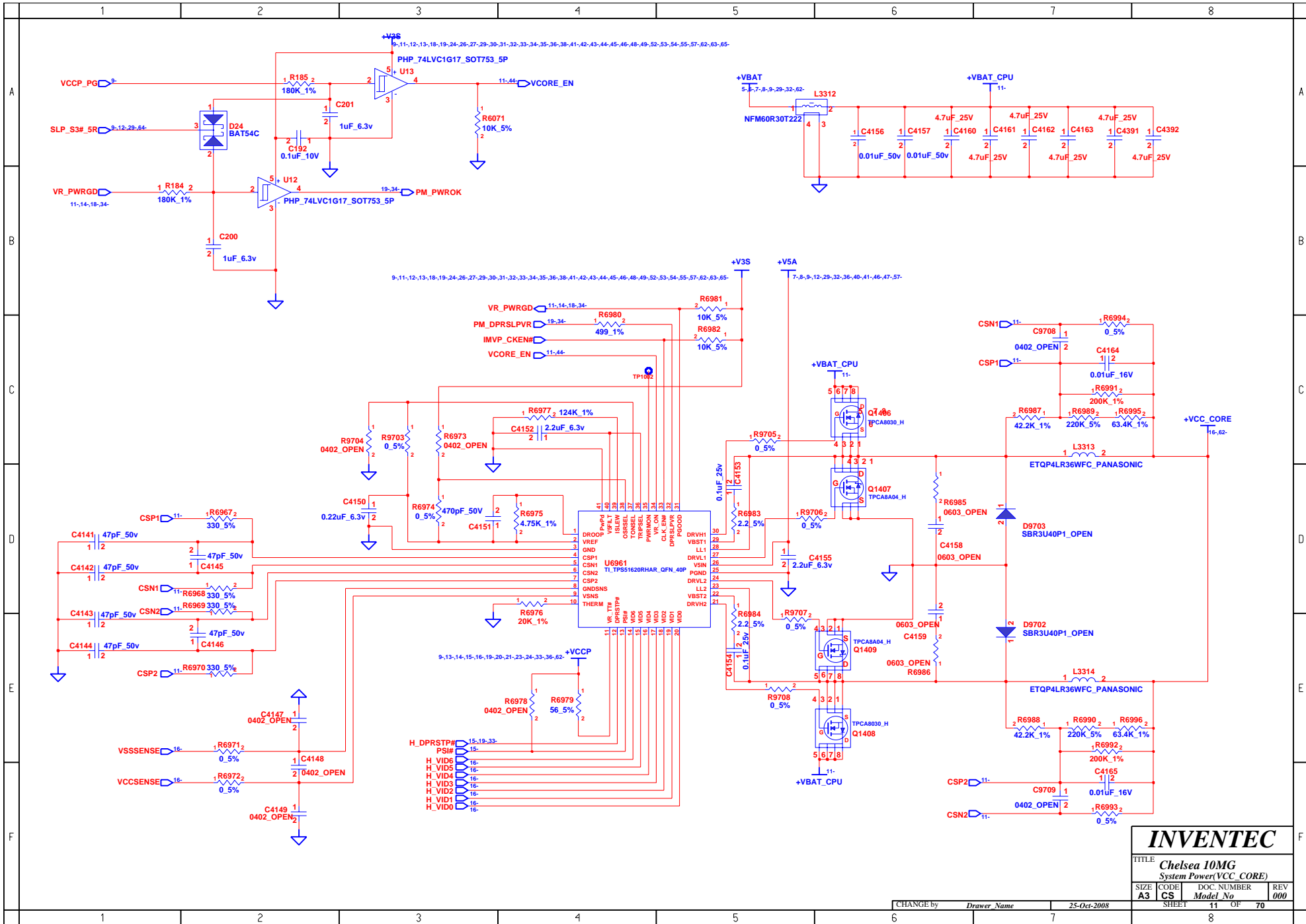

# INVENTEC

TITLE  
**Chelsea 10MG**  
 System Power(VCC\_CORE)

SIZE	CODE	CS	DOC. NUMBER	REV
A3	CS		Model No	000

CHANGE by *Drawer Name* 25-Oct-2008 SHEET 11 OF 70

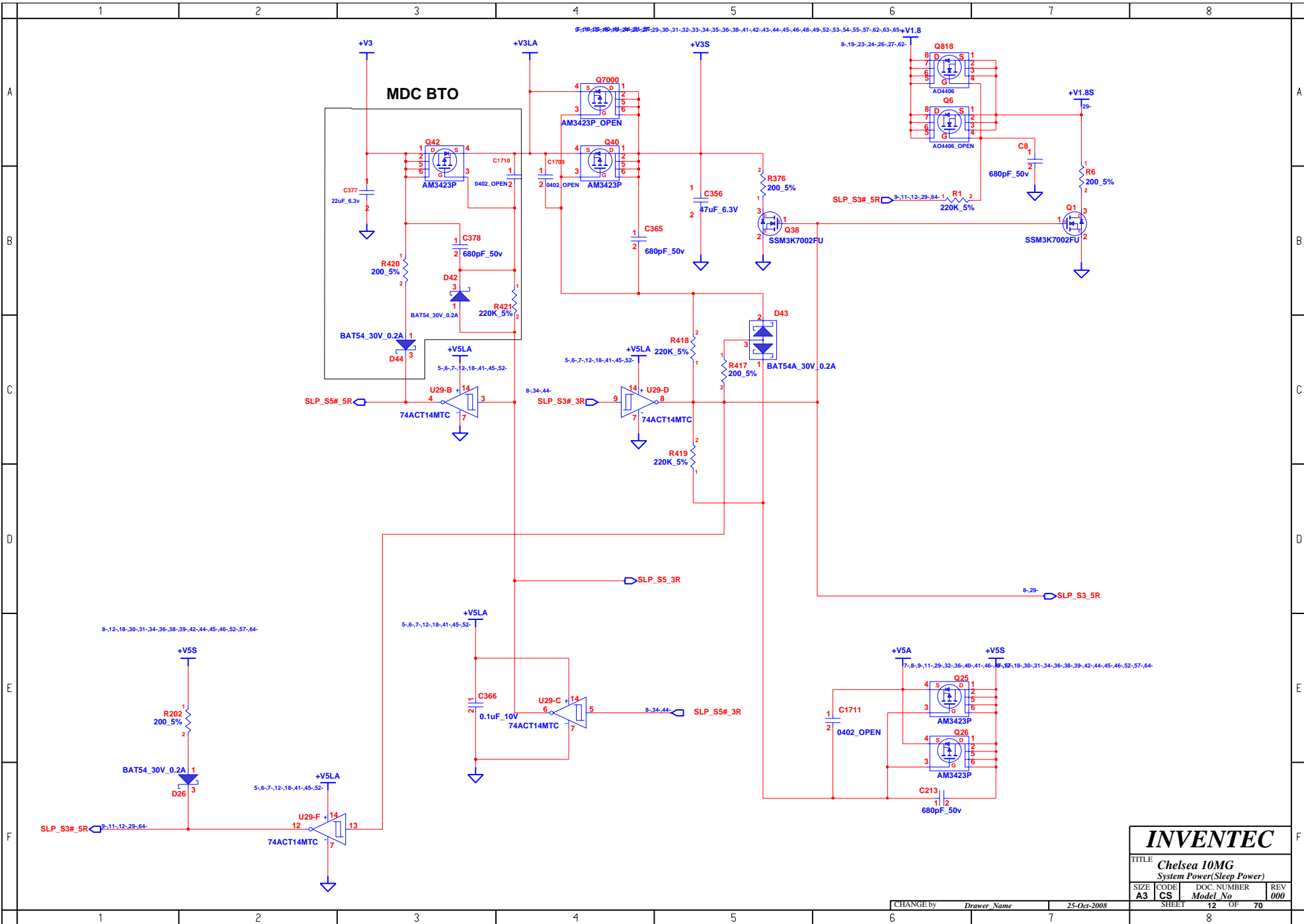

<b>INVENTEC</b>			
TITLE <i>Chelsea 10MG</i> System Power(Sleep Power)			
SIZE <b>A3</b>	CODE <b>CS</b>	DOC. NUMBER Model No	REV <b>000</b>
CHANGE by Drawer Name		25-Oct-2008	
SHEET 12		OF 70	

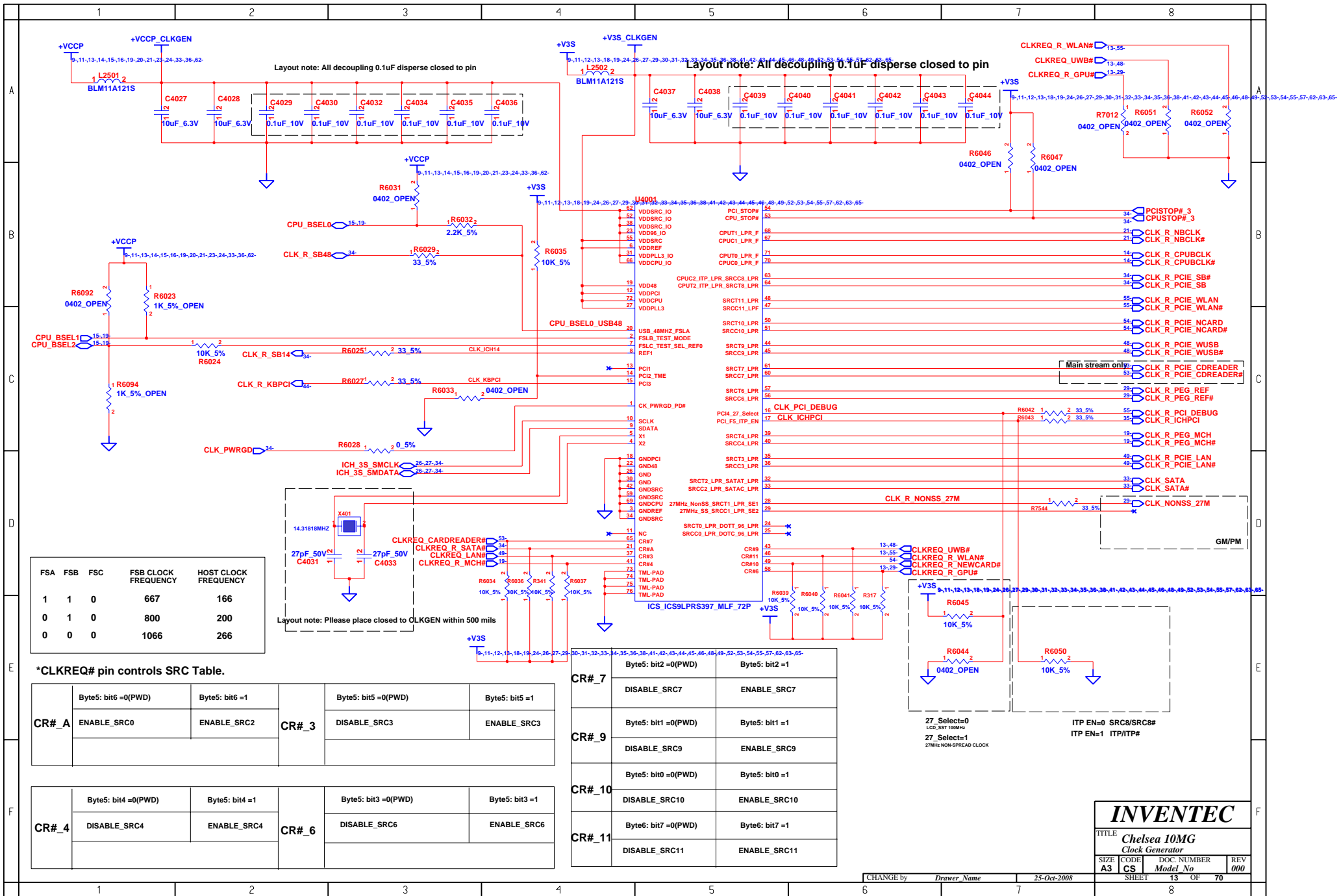

**INVENTEC**

TITLE: **Chelsea 10MG**  
 Clock Generator

SIZE: A3    CODE: CS    DOC. NUMBER: Model No    REV: 000

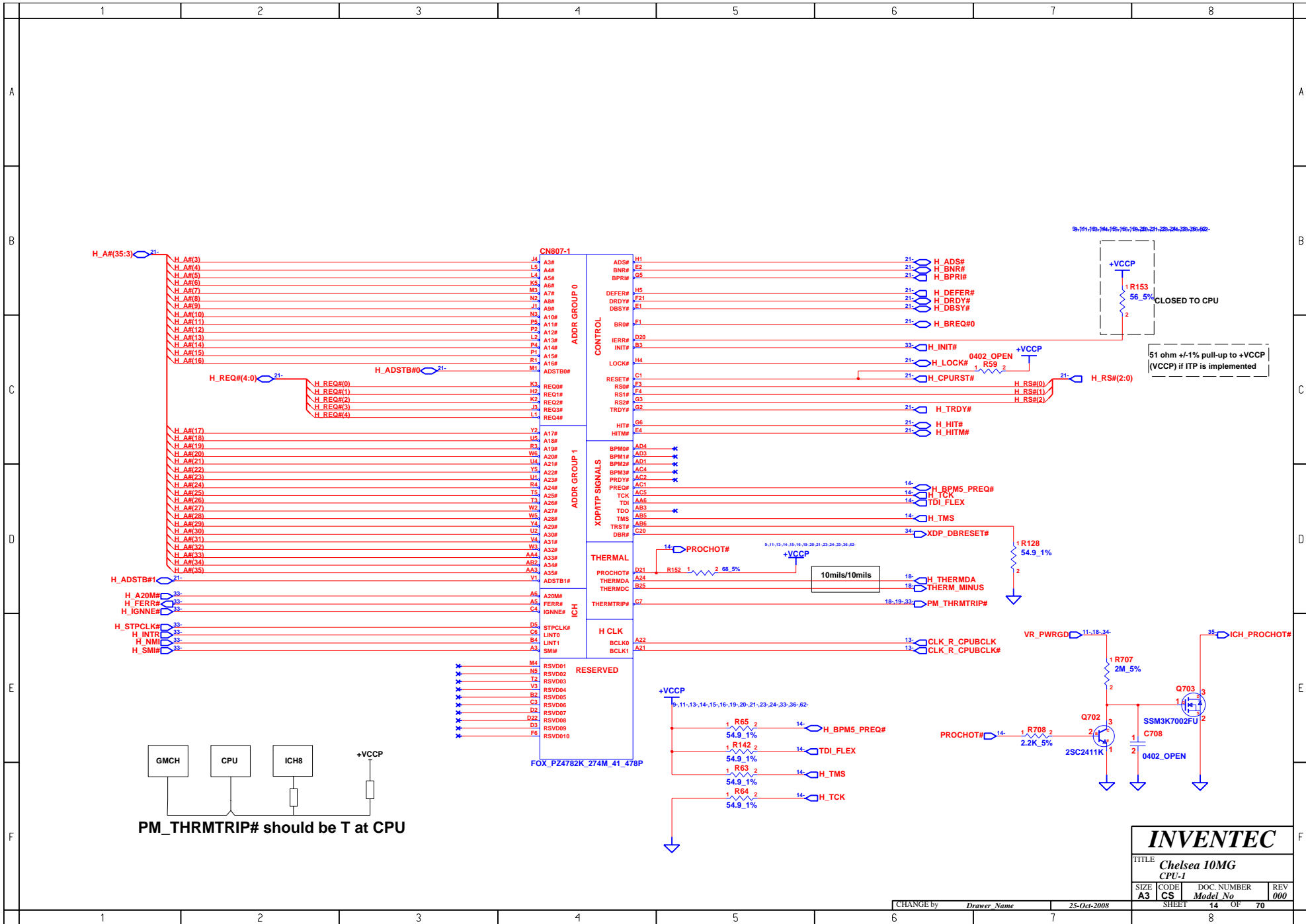

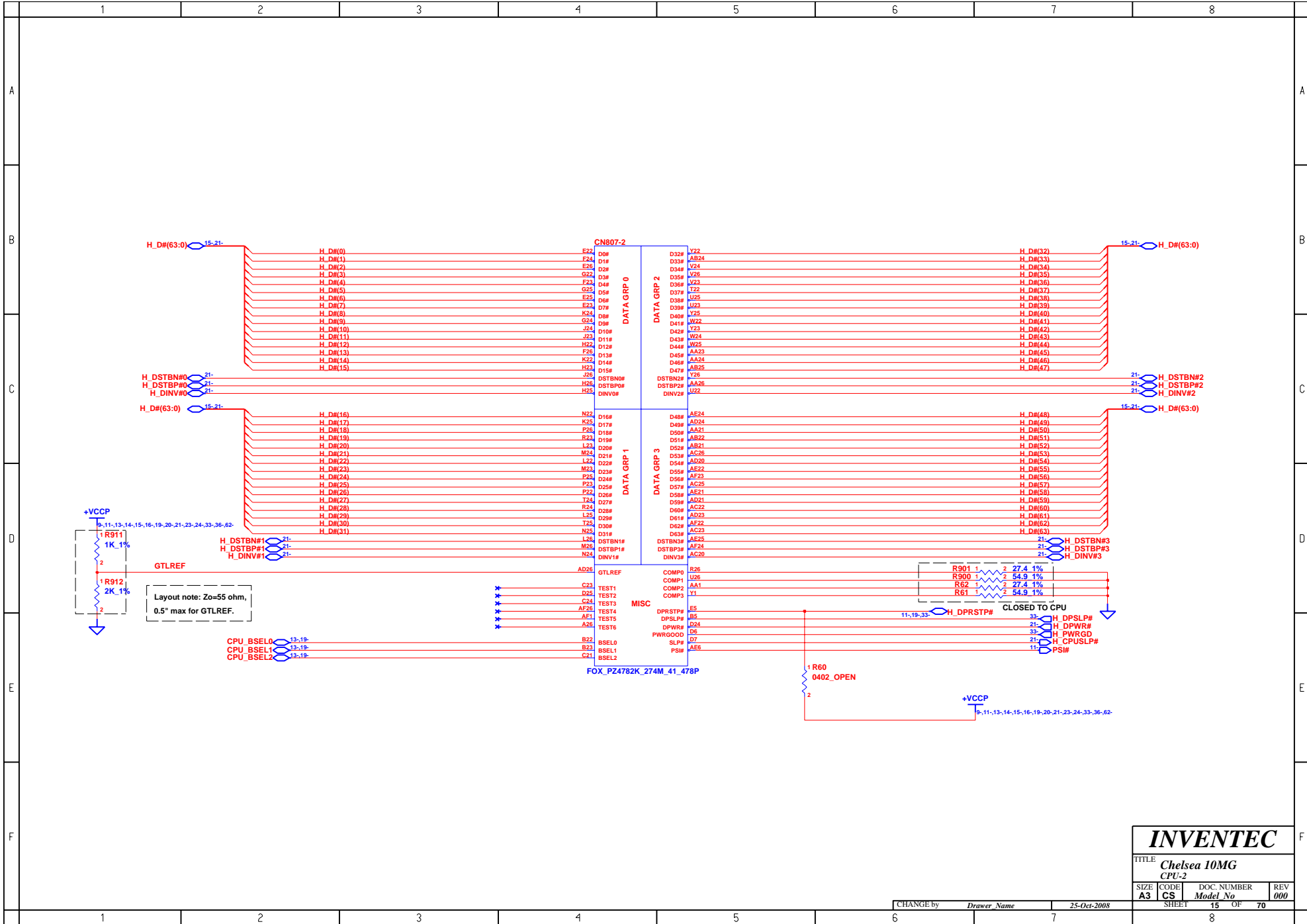

<b>INVENTEC</b>			
TITLE Chelsea 10MG CPU-2			
SIZE A3	CODE CS	DOC. NUMBER Model No	REV 000
CHANGE by Drawer Name		25-Oct-2008	
SHEET 15		OF 70	

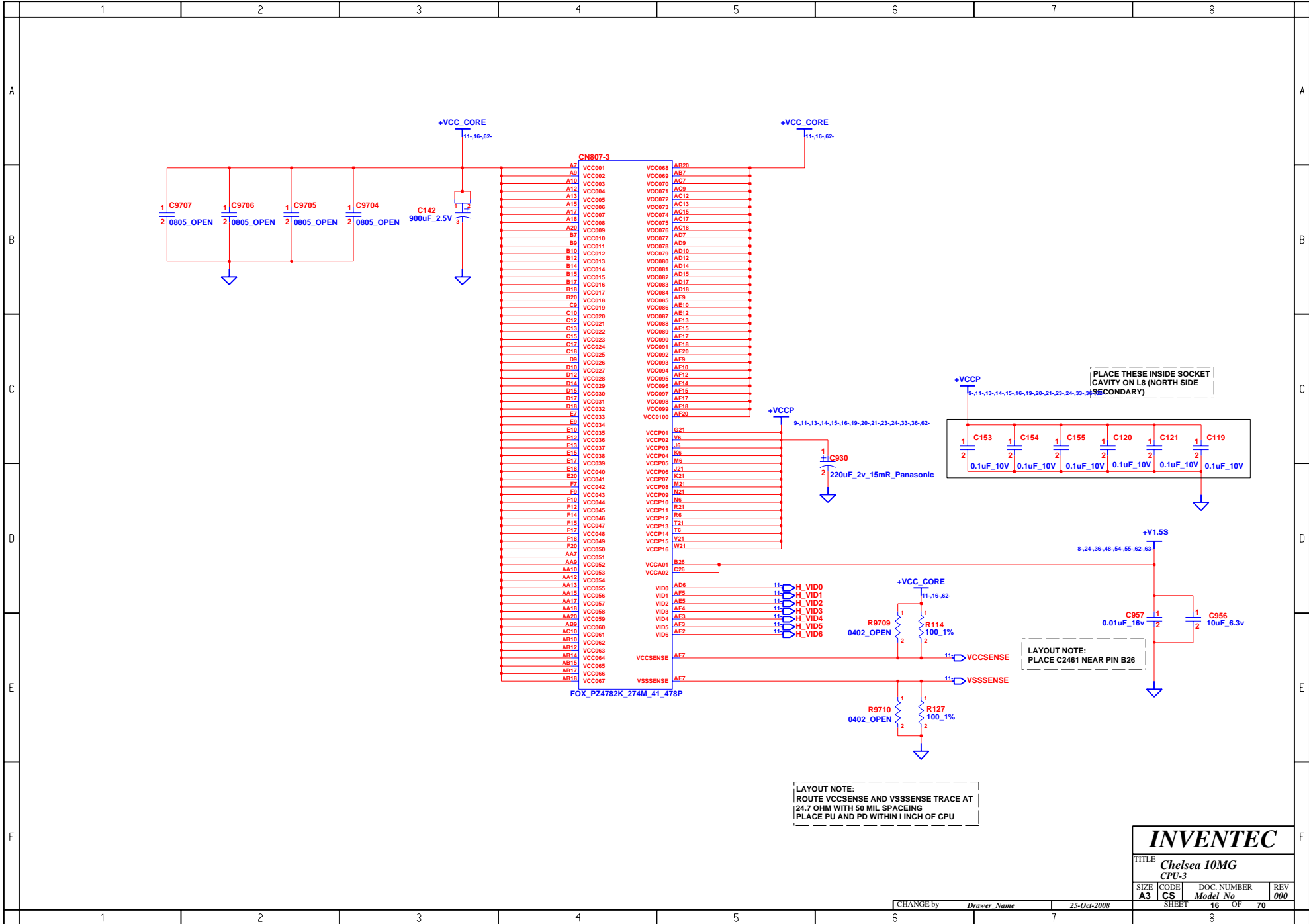

+VCC\_CORE  
11,16,62

+VCC\_CORE  
11,16,62

CN807-3

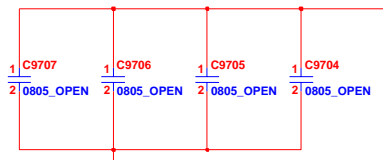

A7	VCC001	AB20	VCC068
A9	VCC002	AB7	VCC069
A10	VCC003	AC7	VCC070
A11	VCC004	AC9	VCC071
A12	VCC005	AC12	VCC072
A13	VCC006	AC13	VCC073
A15	VCC007	AC15	VCC074
A17	VCC008	AC17	VCC075
A18	VCC009	AC18	VCC076
A20	VCC010	AD7	VCC077
B7	VCC011	AD9	VCC078
B9	VCC012	AD10	VCC079
B10	VCC013	AD12	VCC080
B12	VCC014	AD14	VCC081
B14	VCC015	AD15	VCC082
B15	VCC016	AD17	VCC083
B17	VCC017	AD18	VCC084
B18	VCC018	AE9	VCC085
B20	VCC019	AE10	VCC086
C9	VCC020	AE12	VCC087
C10	VCC021	AE13	VCC088
C12	VCC022	AE15	VCC089
C13	VCC023	AE17	VCC090
C15	VCC024	AE18	VCC091
C17	VCC025	AE20	VCC092
C18	VCC026	AF9	VCC093
D9	VCC027	AF10	VCC094
D10	VCC028	AF12	VCC095
D12	VCC029	AF14	VCC096
D14	VCC030	AF15	VCC097
D15	VCC031	AF17	VCC098
D17	VCC032	AF18	VCC099
D18	VCC033	AF20	VCC100
E7	VCC034	G21	VCC081
E9	VCC035	V6	VCC082
E10	VCC036	V6	VCC083
E12	VCC037	J6	VCC084
E13	VCC038	KE	VCC085
E15	VCC039	ME	VCC086
E17	VCC040	ME	VCC087
E18	VCC041	K21	VCC088
E20	VCC042	VCC08	VCC089
F7	VCC043	N21	VCC090
F9	VCC044	N6	VCC091
F10	VCC045	N6	VCC092
F12	VCC046	R21	VCC093
F14	VCC047	T21	VCC094
F15	VCC048	T6	VCC095
F17	VCC049	V21	VCC096
F18	VCC050	W21	VCC097
F20	VCC051		
AA7	VCC052		
AA9	VCC053		
AA10	VCC054		
AA12	VCC055		
AA13	VCC056		
AA15	VCC057		
AA17	VCC058		
AA18	VCC059		
AA20	VCC060		
AB9	VCC061		
AB10	VCC062		
AB12	VCC063		
AB14	VCC064		
AB15	VCC065		
AB17	VCC066		
AB18	VCC067		

FOX\_P24782K\_274M\_41\_478P

PLACE THESE INSIDE SOCKET CAVITY ON L8 (NORTH SIDE SECONDARY)

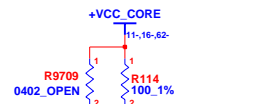
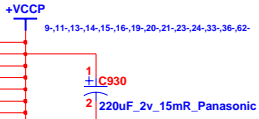
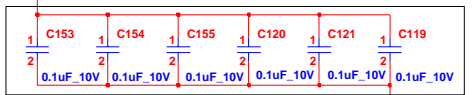

LAYOUT NOTE:  
PLACE C2461 NEAR PIN B26

LAYOUT NOTE:  
ROUTE VCCSENSE AND VSSSENSE TRACE AT 24.7 OHM WITH 50 MIL SPACING  
PLACE PU AND PD WITHIN 1 INCH OF CPU

+V1.5S  
8,24,36,48,54,55,62,63

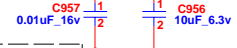



	1	2	3	4	5	6	7	8																																																																																																																																																																																																																																																																																																																																									
A	<p style="color: red; font-weight: bold;">CPU-4</p> <table border="1" style="margin: auto; border-collapse: collapse;"> <tr><td>A4</td><td>VSS001</td><td>VSS002</td><td>P6</td></tr> <tr><td>A8</td><td>VSS002</td><td>VSS003</td><td>P21</td></tr> <tr><td>A11</td><td>VSS003</td><td>VSS004</td><td>P24</td></tr> <tr><td>A14</td><td>VSS004</td><td>VSS005</td><td>R2</td></tr> <tr><td>A16</td><td>VSS005</td><td>VSS006</td><td>R5</td></tr> <tr><td>A19</td><td>VSS006</td><td>VSS007</td><td>R22</td></tr> <tr><td>A23</td><td>VSS007</td><td>VSS008</td><td>R25</td></tr> <tr><td>A24</td><td>VSS008</td><td>VSS009</td><td>T1</td></tr> <tr><td>A25</td><td>VSS009</td><td>VSS010</td><td>T4</td></tr> <tr><td>B6</td><td>VSS010</td><td>VSS011</td><td>T23</td></tr> <tr><td>B8</td><td>VSS011</td><td>VSS012</td><td>T26</td></tr> <tr><td>B11</td><td>VSS012</td><td>VSS013</td><td>U3</td></tr> <tr><td>B13</td><td>VSS013</td><td>VSS014</td><td>U6</td></tr> <tr><td>B16</td><td>VSS014</td><td>VSS015</td><td>U21</td></tr> <tr><td>B19</td><td>VSS015</td><td>VSS016</td><td>U24</td></tr> <tr><td>B21</td><td>VSS016</td><td>VSS017</td><td>V2</td></tr> <tr><td>B24</td><td>VSS017</td><td>VSS018</td><td>V5</td></tr> <tr><td>C5</td><td>VSS018</td><td>VSS019</td><td>V22</td></tr> <tr><td>C8</td><td>VSS019</td><td>VSS020</td><td>V25</td></tr> <tr><td>C11</td><td>VSS020</td><td>VSS021</td><td>W1</td></tr> <tr><td>C14</td><td>VSS021</td><td>VSS022</td><td>W4</td></tr> <tr><td>C16</td><td>VSS022</td><td>VSS023</td><td>W23</td></tr> <tr><td>C19</td><td>VSS023</td><td>VSS024</td><td>W26</td></tr> <tr><td>C22</td><td>VSS024</td><td>VSS025</td><td>Y3</td></tr> <tr><td>C25</td><td>VSS025</td><td>VSS026</td><td>Y6</td></tr> <tr><td>D1</td><td>VSS026</td><td>VSS027</td><td>Y21</td></tr> <tr><td>D4</td><td>VSS027</td><td>VSS028</td><td>Y24</td></tr> <tr><td>D8</td><td>VSS028</td><td>VSS029</td><td>AA2</td></tr> <tr><td>D11</td><td>VSS029</td><td>VSS030</td><td>AA5</td></tr> <tr><td>D13</td><td>VSS030</td><td>VSS031</td><td>AA8</td></tr> <tr><td>D16</td><td>VSS031</td><td>VSS032</td><td>AA11</td></tr> <tr><td>D19</td><td>VSS032</td><td>VSS033</td><td>AA14</td></tr> <tr><td>D23</td><td>VSS033</td><td>VSS034</td><td>AA16</td></tr> <tr><td>D26</td><td>VSS034</td><td>VSS035</td><td>AA19</td></tr> <tr><td>E3</td><td>VSS035</td><td>VSS036</td><td>AA22</td></tr> <tr><td>E6</td><td>VSS036</td><td>VSS037</td><td>AA25</td></tr> <tr><td>E8</td><td>VSS037</td><td>VSS038</td><td>AB1</td></tr> <tr><td>E11</td><td>VSS038</td><td>VSS039</td><td>AB4</td></tr> <tr><td>E14</td><td>VSS039</td><td>VSS040</td><td>AB8</td></tr> <tr><td>E16</td><td>VSS040</td><td>VSS041</td><td>AB11</td></tr> <tr><td>E19</td><td>VSS041</td><td>VSS042</td><td>AB13</td></tr> <tr><td>E21</td><td>VSS042</td><td>VSS043</td><td>AB16</td></tr> <tr><td>E24</td><td>VSS043</td><td>VSS044</td><td>AB18</td></tr> <tr><td>F5</td><td>VSS044</td><td>VSS045</td><td>AB23</td></tr> <tr><td>F8</td><td>VSS045</td><td>VSS046</td><td>AB26</td></tr> <tr><td>F11</td><td>VSS046</td><td>VSS047</td><td>AC3</td></tr> <tr><td>F13</td><td>VSS047</td><td>VSS048</td><td>AC6</td></tr> <tr><td>F16</td><td>VSS048</td><td>VSS049</td><td>AC8</td></tr> <tr><td>F19</td><td>VSS049</td><td>VSS050</td><td>AC11</td></tr> <tr><td>F2</td><td>VSS050</td><td>VSS051</td><td>AC14</td></tr> <tr><td>F22</td><td>VSS051</td><td>VSS052</td><td>AC16</td></tr> <tr><td>F25</td><td>VSS052</td><td>VSS053</td><td>AC19</td></tr> <tr><td>G4</td><td>VSS053</td><td>VSS054</td><td>AC21</td></tr> <tr><td>G11</td><td>VSS054</td><td>VSS055</td><td>AC24</td></tr> <tr><td>G23</td><td>VSS055</td><td>VSS056</td><td>AD2</td></tr> <tr><td>G26</td><td>VSS056</td><td>VSS057</td><td>AD5</td></tr> <tr><td>H3</td><td>VSS057</td><td>VSS058</td><td>AD8</td></tr> <tr><td>H6</td><td>VSS058</td><td>VSS059</td><td>AD11</td></tr> <tr><td>H21</td><td>VSS059</td><td>VSS060</td><td>AD13</td></tr> <tr><td>H24</td><td>VSS060</td><td>VSS061</td><td>AD16</td></tr> <tr><td>J4</td><td>VSS061</td><td>VSS062</td><td>AD19</td></tr> <tr><td>J5</td><td>VSS062</td><td>VSS063</td><td>AD22</td></tr> <tr><td>J22</td><td>VSS063</td><td>VSS064</td><td>AD25</td></tr> <tr><td>J25</td><td>VSS064</td><td>VSS065</td><td>AE1</td></tr> <tr><td>K1</td><td>VSS065</td><td>VSS066</td><td>AE4</td></tr> <tr><td>K4</td><td>VSS066</td><td>VSS067</td><td>AE8</td></tr> <tr><td>K23</td><td>VSS067</td><td>VSS068</td><td>AE11</td></tr> <tr><td>K26</td><td>VSS068</td><td>VSS069</td><td>AE14</td></tr> <tr><td>L3</td><td>VSS069</td><td>VSS070</td><td>AE16</td></tr> <tr><td>L6</td><td>VSS070</td><td>VSS071</td><td>AE19</td></tr> <tr><td>L21</td><td>VSS071</td><td>VSS072</td><td>AE23</td></tr> <tr><td>L24</td><td>VSS072</td><td>VSS073</td><td>AE26</td></tr> <tr><td>M2</td><td>VSS073</td><td>VSS074</td><td>AF</td></tr> <tr><td>M5</td><td>VSS074</td><td>VSS075</td><td>AF6</td></tr> <tr><td>M22</td><td>VSS075</td><td>VSS076</td><td>AF8</td></tr> <tr><td>M25</td><td>VSS076</td><td>VSS077</td><td>AF11</td></tr> <tr><td>N1</td><td>VSS077</td><td>VSS078</td><td>AF13</td></tr> <tr><td>N4</td><td>VSS078</td><td>VSS079</td><td>AF16</td></tr> <tr><td>N23</td><td>VSS079</td><td>VSS080</td><td>AF19</td></tr> <tr><td>N26</td><td>VSS080</td><td>VSS081</td><td>AF21</td></tr> <tr><td>P3</td><td>VSS081</td><td></td><td>AF25</td></tr> <tr><td></td><td></td><td></td><td>AF25</td></tr> </table> <p style="color: blue; font-weight: bold; text-align: center;">FOX_PZ4782K_274M_41_478P</p>									A4	VSS001	VSS002	P6	A8	VSS002	VSS003	P21	A11	VSS003	VSS004	P24	A14	VSS004	VSS005	R2	A16	VSS005	VSS006	R5	A19	VSS006	VSS007	R22	A23	VSS007	VSS008	R25	A24	VSS008	VSS009	T1	A25	VSS009	VSS010	T4	B6	VSS010	VSS011	T23	B8	VSS011	VSS012	T26	B11	VSS012	VSS013	U3	B13	VSS013	VSS014	U6	B16	VSS014	VSS015	U21	B19	VSS015	VSS016	U24	B21	VSS016	VSS017	V2	B24	VSS017	VSS018	V5	C5	VSS018	VSS019	V22	C8	VSS019	VSS020	V25	C11	VSS020	VSS021	W1	C14	VSS021	VSS022	W4	C16	VSS022	VSS023	W23	C19	VSS023	VSS024	W26	C22	VSS024	VSS025	Y3	C25	VSS025	VSS026	Y6	D1	VSS026	VSS027	Y21	D4	VSS027	VSS028	Y24	D8	VSS028	VSS029	AA2	D11	VSS029	VSS030	AA5	D13	VSS030	VSS031	AA8	D16	VSS031	VSS032	AA11	D19	VSS032	VSS033	AA14	D23	VSS033	VSS034	AA16	D26	VSS034	VSS035	AA19	E3	VSS035	VSS036	AA22	E6	VSS036	VSS037	AA25	E8	VSS037	VSS038	AB1	E11	VSS038	VSS039	AB4	E14	VSS039	VSS040	AB8	E16	VSS040	VSS041	AB11	E19	VSS041	VSS042	AB13	E21	VSS042	VSS043	AB16	E24	VSS043	VSS044	AB18	F5	VSS044	VSS045	AB23	F8	VSS045	VSS046	AB26	F11	VSS046	VSS047	AC3	F13	VSS047	VSS048	AC6	F16	VSS048	VSS049	AC8	F19	VSS049	VSS050	AC11	F2	VSS050	VSS051	AC14	F22	VSS051	VSS052	AC16	F25	VSS052	VSS053	AC19	G4	VSS053	VSS054	AC21	G11	VSS054	VSS055	AC24	G23	VSS055	VSS056	AD2	G26	VSS056	VSS057	AD5	H3	VSS057	VSS058	AD8	H6	VSS058	VSS059	AD11	H21	VSS059	VSS060	AD13	H24	VSS060	VSS061	AD16	J4	VSS061	VSS062	AD19	J5	VSS062	VSS063	AD22	J22	VSS063	VSS064	AD25	J25	VSS064	VSS065	AE1	K1	VSS065	VSS066	AE4	K4	VSS066	VSS067	AE8	K23	VSS067	VSS068	AE11	K26	VSS068	VSS069	AE14	L3	VSS069	VSS070	AE16	L6	VSS070	VSS071	AE19	L21	VSS071	VSS072	AE23	L24	VSS072	VSS073	AE26	M2	VSS073	VSS074	AF	M5	VSS074	VSS075	AF6	M22	VSS075	VSS076	AF8	M25	VSS076	VSS077	AF11	N1	VSS077	VSS078	AF13	N4	VSS078	VSS079	AF16	N23	VSS079	VSS080	AF19	N26	VSS080	VSS081	AF21	P3	VSS081		AF25				AF25
A4	VSS001	VSS002	P6																																																																																																																																																																																																																																																																																																																																														
A8	VSS002	VSS003	P21																																																																																																																																																																																																																																																																																																																																														
A11	VSS003	VSS004	P24																																																																																																																																																																																																																																																																																																																																														
A14	VSS004	VSS005	R2																																																																																																																																																																																																																																																																																																																																														
A16	VSS005	VSS006	R5																																																																																																																																																																																																																																																																																																																																														
A19	VSS006	VSS007	R22																																																																																																																																																																																																																																																																																																																																														
A23	VSS007	VSS008	R25																																																																																																																																																																																																																																																																																																																																														
A24	VSS008	VSS009	T1																																																																																																																																																																																																																																																																																																																																														
A25	VSS009	VSS010	T4																																																																																																																																																																																																																																																																																																																																														
B6	VSS010	VSS011	T23																																																																																																																																																																																																																																																																																																																																														
B8	VSS011	VSS012	T26																																																																																																																																																																																																																																																																																																																																														
B11	VSS012	VSS013	U3																																																																																																																																																																																																																																																																																																																																														
B13	VSS013	VSS014	U6																																																																																																																																																																																																																																																																																																																																														
B16	VSS014	VSS015	U21																																																																																																																																																																																																																																																																																																																																														
B19	VSS015	VSS016	U24																																																																																																																																																																																																																																																																																																																																														
B21	VSS016	VSS017	V2																																																																																																																																																																																																																																																																																																																																														
B24	VSS017	VSS018	V5																																																																																																																																																																																																																																																																																																																																														
C5	VSS018	VSS019	V22																																																																																																																																																																																																																																																																																																																																														
C8	VSS019	VSS020	V25																																																																																																																																																																																																																																																																																																																																														
C11	VSS020	VSS021	W1																																																																																																																																																																																																																																																																																																																																														
C14	VSS021	VSS022	W4																																																																																																																																																																																																																																																																																																																																														
C16	VSS022	VSS023	W23																																																																																																																																																																																																																																																																																																																																														
C19	VSS023	VSS024	W26																																																																																																																																																																																																																																																																																																																																														
C22	VSS024	VSS025	Y3																																																																																																																																																																																																																																																																																																																																														
C25	VSS025	VSS026	Y6																																																																																																																																																																																																																																																																																																																																														
D1	VSS026	VSS027	Y21																																																																																																																																																																																																																																																																																																																																														
D4	VSS027	VSS028	Y24																																																																																																																																																																																																																																																																																																																																														
D8	VSS028	VSS029	AA2																																																																																																																																																																																																																																																																																																																																														
D11	VSS029	VSS030	AA5																																																																																																																																																																																																																																																																																																																																														
D13	VSS030	VSS031	AA8																																																																																																																																																																																																																																																																																																																																														
D16	VSS031	VSS032	AA11																																																																																																																																																																																																																																																																																																																																														
D19	VSS032	VSS033	AA14																																																																																																																																																																																																																																																																																																																																														
D23	VSS033	VSS034	AA16																																																																																																																																																																																																																																																																																																																																														
D26	VSS034	VSS035	AA19																																																																																																																																																																																																																																																																																																																																														
E3	VSS035	VSS036	AA22																																																																																																																																																																																																																																																																																																																																														
E6	VSS036	VSS037	AA25																																																																																																																																																																																																																																																																																																																																														
E8	VSS037	VSS038	AB1																																																																																																																																																																																																																																																																																																																																														
E11	VSS038	VSS039	AB4																																																																																																																																																																																																																																																																																																																																														
E14	VSS039	VSS040	AB8																																																																																																																																																																																																																																																																																																																																														
E16	VSS040	VSS041	AB11																																																																																																																																																																																																																																																																																																																																														
E19	VSS041	VSS042	AB13																																																																																																																																																																																																																																																																																																																																														
E21	VSS042	VSS043	AB16																																																																																																																																																																																																																																																																																																																																														
E24	VSS043	VSS044	AB18																																																																																																																																																																																																																																																																																																																																														
F5	VSS044	VSS045	AB23																																																																																																																																																																																																																																																																																																																																														
F8	VSS045	VSS046	AB26																																																																																																																																																																																																																																																																																																																																														
F11	VSS046	VSS047	AC3																																																																																																																																																																																																																																																																																																																																														
F13	VSS047	VSS048	AC6																																																																																																																																																																																																																																																																																																																																														
F16	VSS048	VSS049	AC8																																																																																																																																																																																																																																																																																																																																														
F19	VSS049	VSS050	AC11																																																																																																																																																																																																																																																																																																																																														
F2	VSS050	VSS051	AC14																																																																																																																																																																																																																																																																																																																																														
F22	VSS051	VSS052	AC16																																																																																																																																																																																																																																																																																																																																														
F25	VSS052	VSS053	AC19																																																																																																																																																																																																																																																																																																																																														
G4	VSS053	VSS054	AC21																																																																																																																																																																																																																																																																																																																																														
G11	VSS054	VSS055	AC24																																																																																																																																																																																																																																																																																																																																														
G23	VSS055	VSS056	AD2																																																																																																																																																																																																																																																																																																																																														
G26	VSS056	VSS057	AD5																																																																																																																																																																																																																																																																																																																																														
H3	VSS057	VSS058	AD8																																																																																																																																																																																																																																																																																																																																														
H6	VSS058	VSS059	AD11																																																																																																																																																																																																																																																																																																																																														
H21	VSS059	VSS060	AD13																																																																																																																																																																																																																																																																																																																																														
H24	VSS060	VSS061	AD16																																																																																																																																																																																																																																																																																																																																														
J4	VSS061	VSS062	AD19																																																																																																																																																																																																																																																																																																																																														
J5	VSS062	VSS063	AD22																																																																																																																																																																																																																																																																																																																																														
J22	VSS063	VSS064	AD25																																																																																																																																																																																																																																																																																																																																														
J25	VSS064	VSS065	AE1																																																																																																																																																																																																																																																																																																																																														
K1	VSS065	VSS066	AE4																																																																																																																																																																																																																																																																																																																																														
K4	VSS066	VSS067	AE8																																																																																																																																																																																																																																																																																																																																														
K23	VSS067	VSS068	AE11																																																																																																																																																																																																																																																																																																																																														
K26	VSS068	VSS069	AE14																																																																																																																																																																																																																																																																																																																																														
L3	VSS069	VSS070	AE16																																																																																																																																																																																																																																																																																																																																														
L6	VSS070	VSS071	AE19																																																																																																																																																																																																																																																																																																																																														
L21	VSS071	VSS072	AE23																																																																																																																																																																																																																																																																																																																																														
L24	VSS072	VSS073	AE26																																																																																																																																																																																																																																																																																																																																														
M2	VSS073	VSS074	AF																																																																																																																																																																																																																																																																																																																																														
M5	VSS074	VSS075	AF6																																																																																																																																																																																																																																																																																																																																														
M22	VSS075	VSS076	AF8																																																																																																																																																																																																																																																																																																																																														
M25	VSS076	VSS077	AF11																																																																																																																																																																																																																																																																																																																																														
N1	VSS077	VSS078	AF13																																																																																																																																																																																																																																																																																																																																														
N4	VSS078	VSS079	AF16																																																																																																																																																																																																																																																																																																																																														
N23	VSS079	VSS080	AF19																																																																																																																																																																																																																																																																																																																																														
N26	VSS080	VSS081	AF21																																																																																																																																																																																																																																																																																																																																														
P3	VSS081		AF25																																																																																																																																																																																																																																																																																																																																														
			AF25																																																																																																																																																																																																																																																																																																																																														
B																																																																																																																																																																																																																																																																																																																																																	
C																																																																																																																																																																																																																																																																																																																																																	
D																																																																																																																																																																																																																																																																																																																																																	
E																																																																																																																																																																																																																																																																																																																																																	
F																																																																																																																																																																																																																																																																																																																																																	

INVENTEC			
TITLE <i>Chelsea 10MG CPU-4</i>			
SIZE	CODE	DOC. NUMBER	REV
A3	CS	Model No	000
CHANGE by <i>Drawer Name</i>		25-Oct-2008	
SHEET		OF	
17		70	

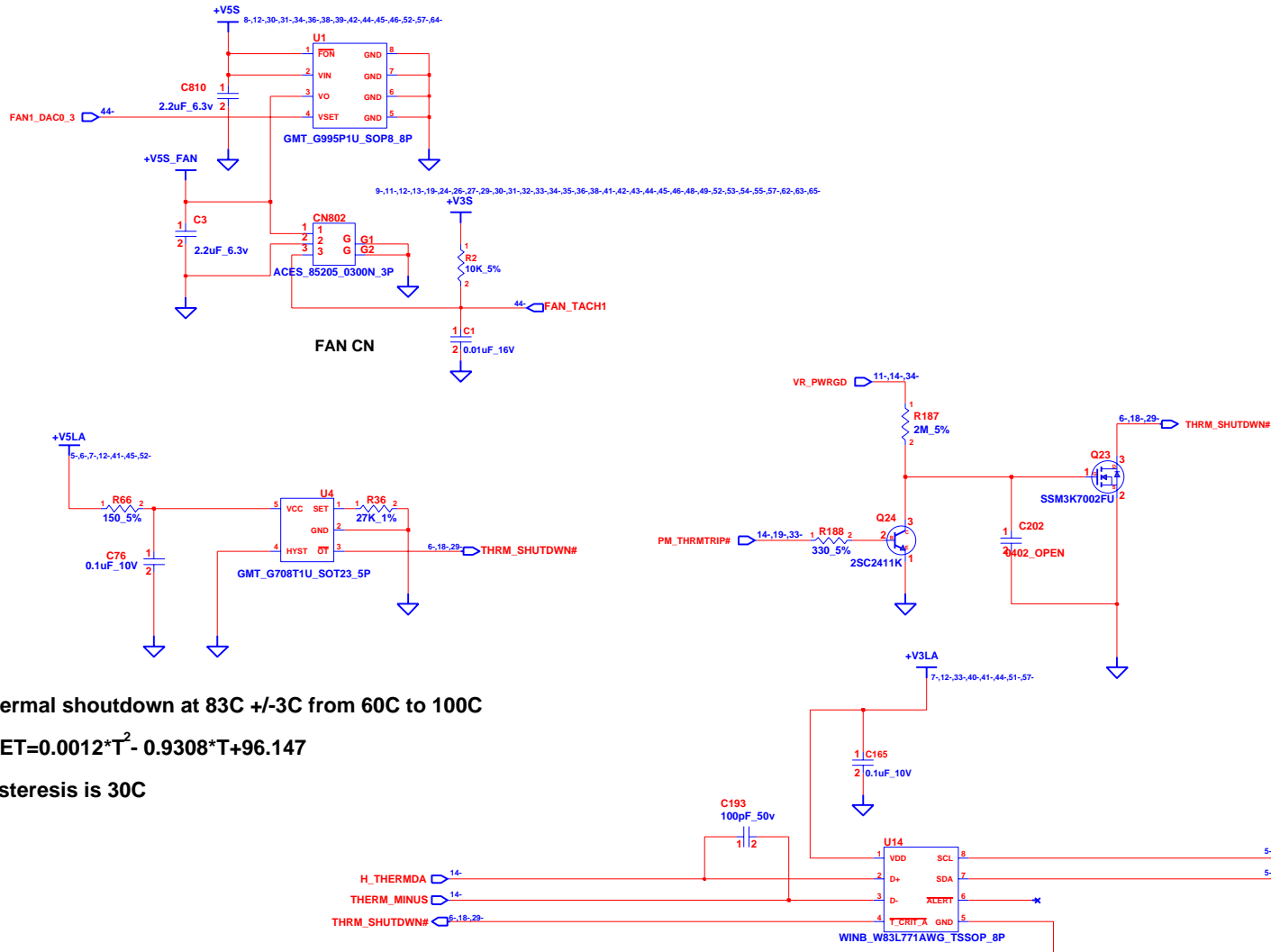

Thermal shutdown at 83C +/-3C from 60C to 100C  
 $RSET=0.0012*T^2 - 0.9308*T+96.147$   
 Hysteresis is 30C

Thermal Sensor For CPU  
 LAYOUT NOTES: PUT THE THERMAL SENSOR CLOSE TO CPU

<b>INVENTEC</b>			
TITLE <i>Chelsea 10MG</i> Fan & Thermal Sensor			
SIZE <b>A3</b>	CODE <b>CS</b>	DOC NUMBER Model No	REV <b>000</b>
CHANGE by Drawer Name		25-Oct-2008	SHEET 18 OF 70

NOTE : USE 4K-OHM RESISTOR WHEN INSTALLING PULL-UP/PULL-DOWN RESISTOR ON ANY MCH-CFG CONNECTION/PINS.

MCH_CFG(5)	LOW=DMIx2 HIGH=DMIx4	MCH_CFG(7) (CPU Strap)	LOW=RSVD HIGH=Mobile CPU	MCH_CFG(9) PCIe Graphics Lane	LOW=Reverse Lane HIGH=Normal operation
------------	-------------------------	---------------------------	-----------------------------	----------------------------------	---

MCH_CFG(13:12) XOR/ALLZ	00=PARTIAL CLOCK GATING DISABLE 01=XOR MODE ENABLE 10=ALL-Z MODE ENABLE 11=NORMAL OPERATION	MCH_CFG(16) FSB Dynamic ODT	LOW=Dynamic ODT HIGH=Dynamic ODT Enable	MCH_CFG(6)	LOW=TPM Enable HIGH=TPM Disable
----------------------------	--	--------------------------------	--	------------	------------------------------------

NOTE: CFG[2:0] STRP : 010b : 800 MT/S  
011b : 667 MT/S

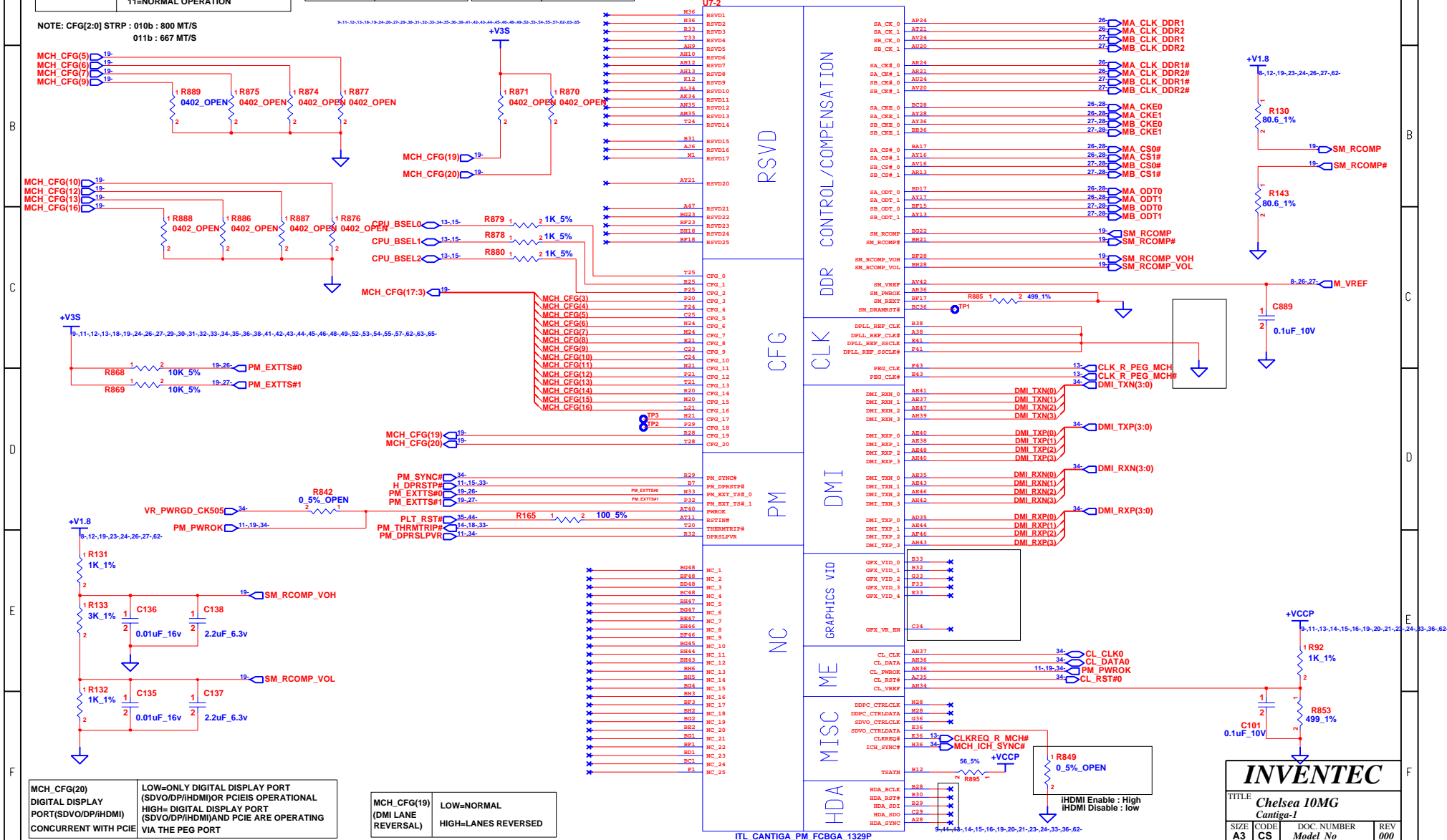

ITL\_CANTIGA\_PM\_FCBGA\_1329P

MCH_CFG(20) DIGITAL DISPLAY PORT (SDVO/DP/HDMI)	LOW=ONLY DIGITAL DISPLAY PORT (SDVO/DP/HDMI) OR PCIE IS OPERATIONAL HIGH= DIGITAL DISPLAY PORT (SDVO/DP/HDMI) AND PCIE ARE OPERATING CONCURRENT WITH PCIE VIA THE PEG PORT
--	---

MCH_CFG(19) LOW=REVERSAL	LOW=NORMAL HIGH=LANES REVERSED
-----------------------------	-----------------------------------

**INVENTEC**

TITLE: *Chelsea 10MG Cantiga-1*

SIZE	CODE	DOC. NUMBER	REV
A3	CS	Model No	000

SHEET 19 OF 70

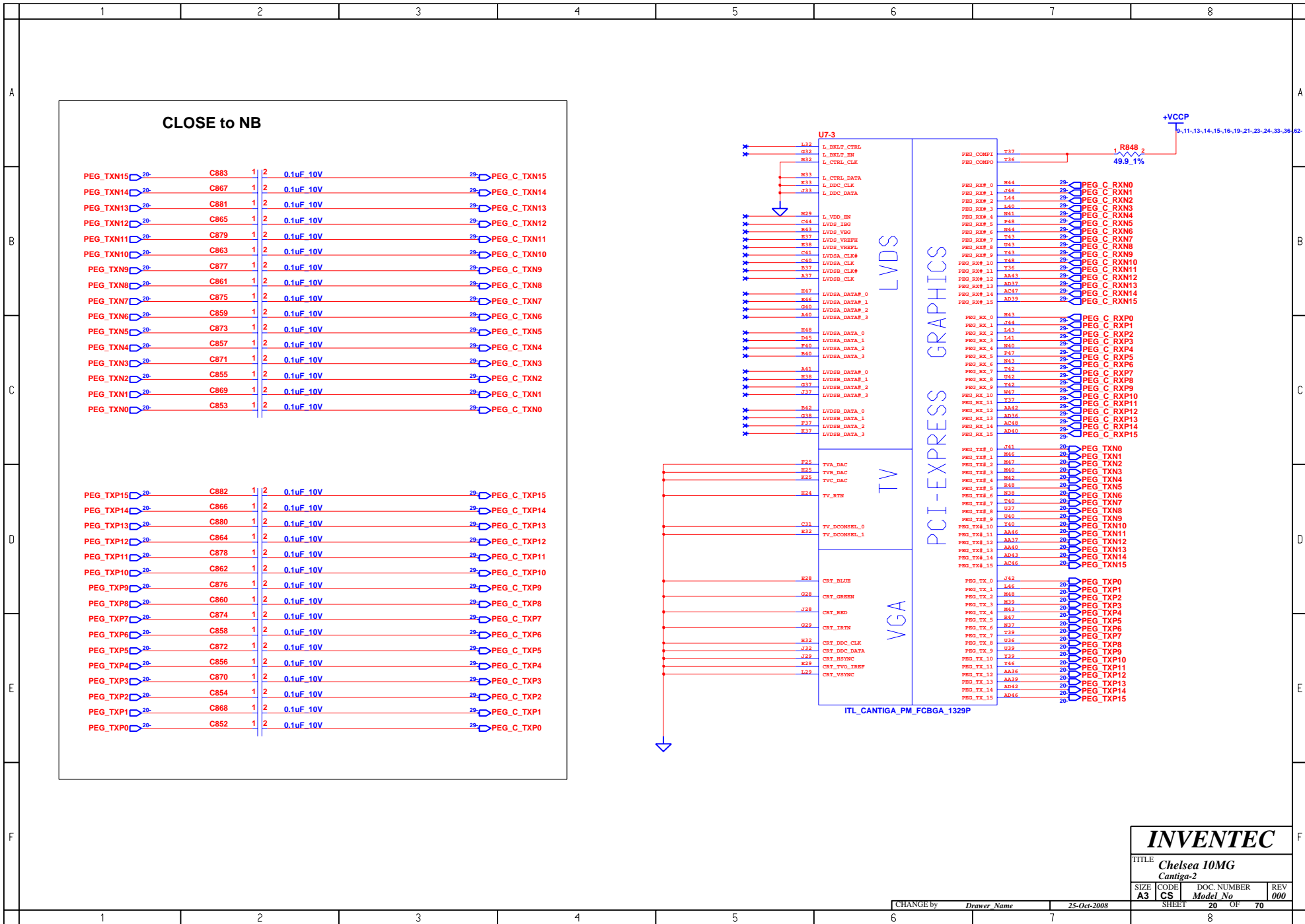

**INVENTEC**

TITLE  
*Chelsea 10MG*  
 Cantiga-2

SIZE	CODE	DOC. NUMBER	REV
A3	CS	Model No	000

CHANGE by *Drawer Name* 25-Oct-2008

SHEET 20 OF 70

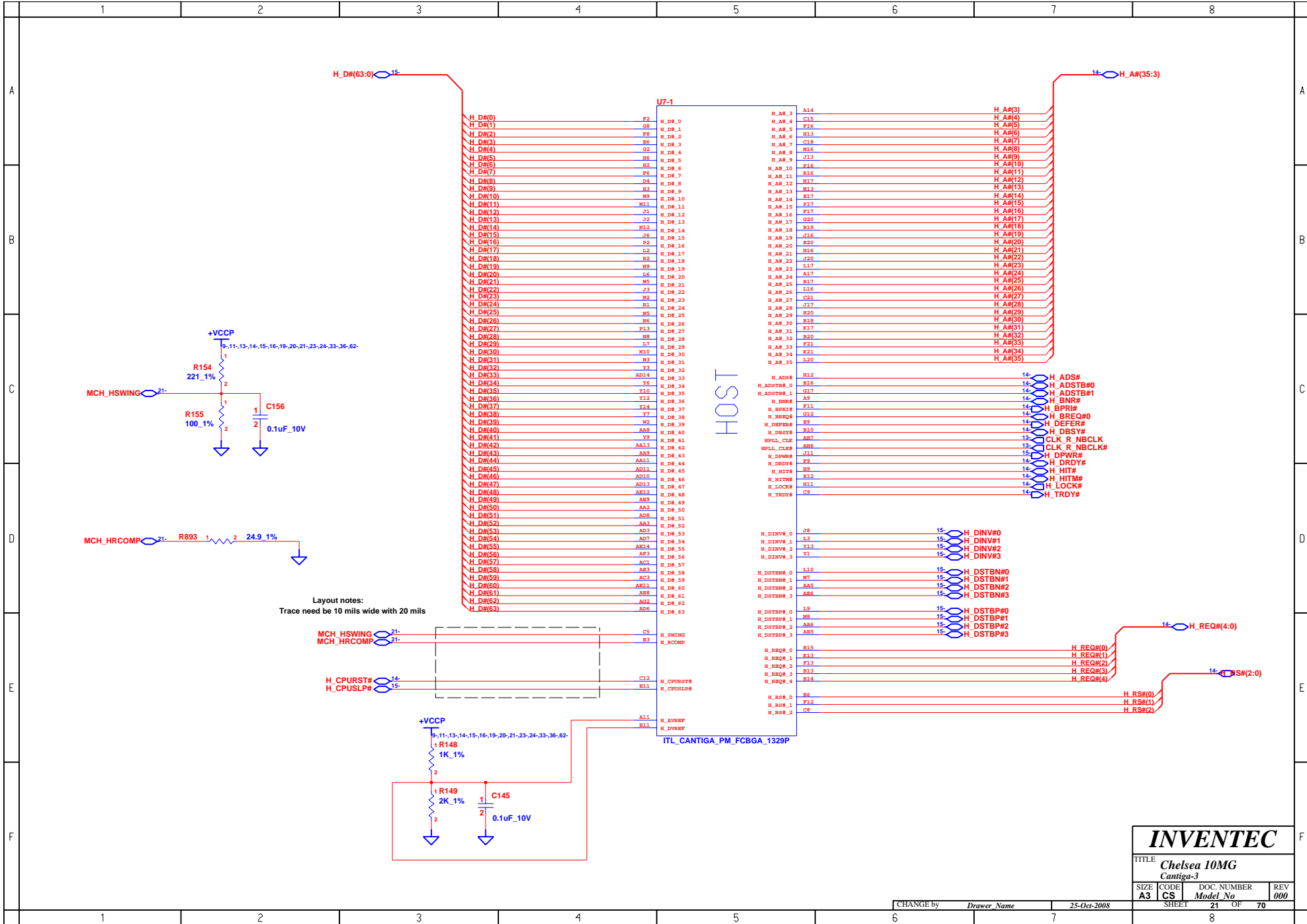

**INVENTEC**

TITLE  
**Chelsea 10MG**  
 Cantiga-3

SIZE	CODE	DOC. NUMBER	REV
A3	CS	Model No	000

CHANGE by *Drawer Name* 25-Oct-2008 SHEET 21 OF 70

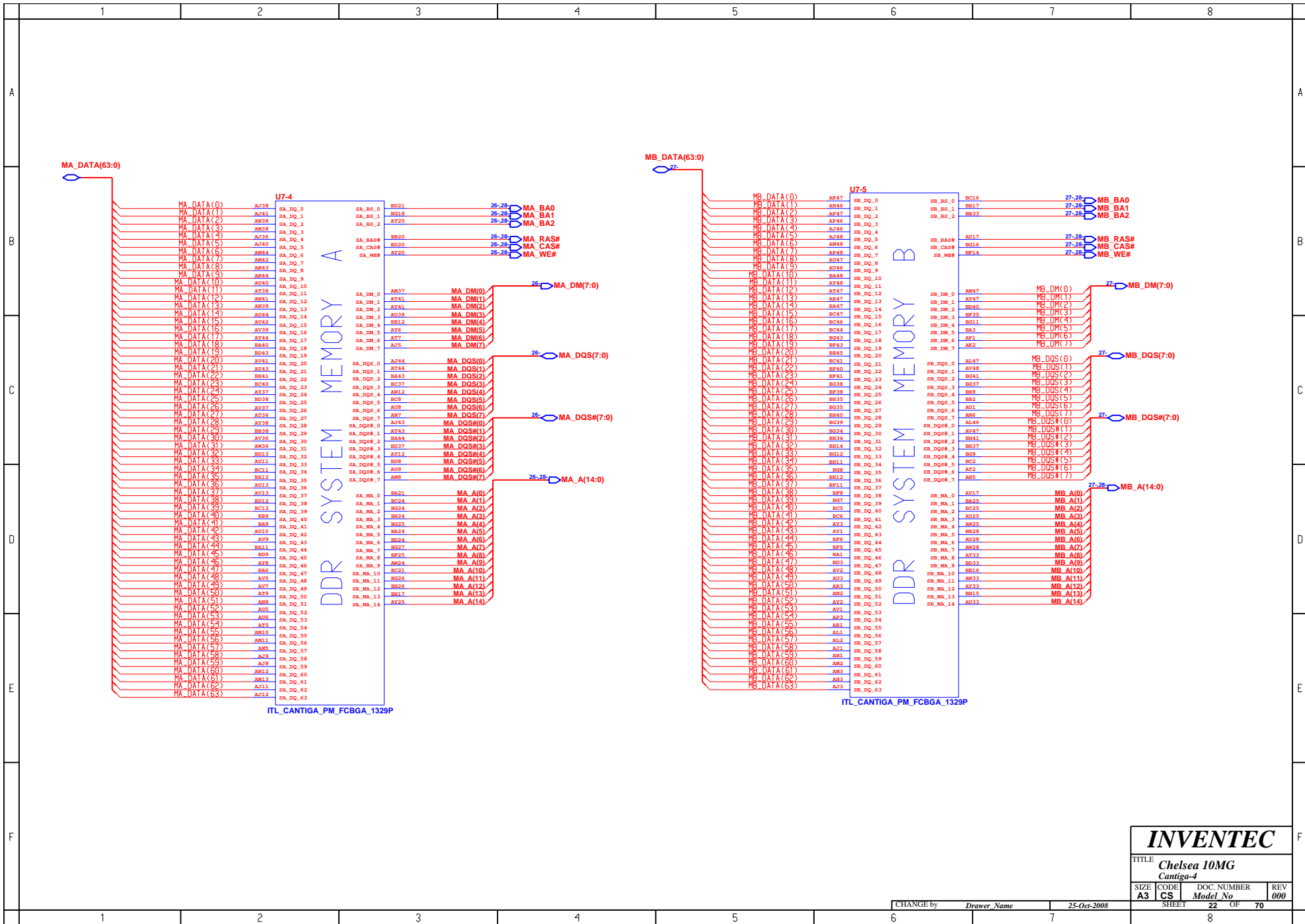

**INVENTEC**

TITLE  
**Chelsea 10MG**  
**Cantiga-4**

SIZE <b>A3</b>	CODE <b>CS</b>	DOC. NUMBER <i>Model No</i>	REV <b>000</b>
-------------------	-------------------	--------------------------------	-------------------

CHANGE by *Drawer Name* 25-Oct-2008

SHEET 22 OF 70

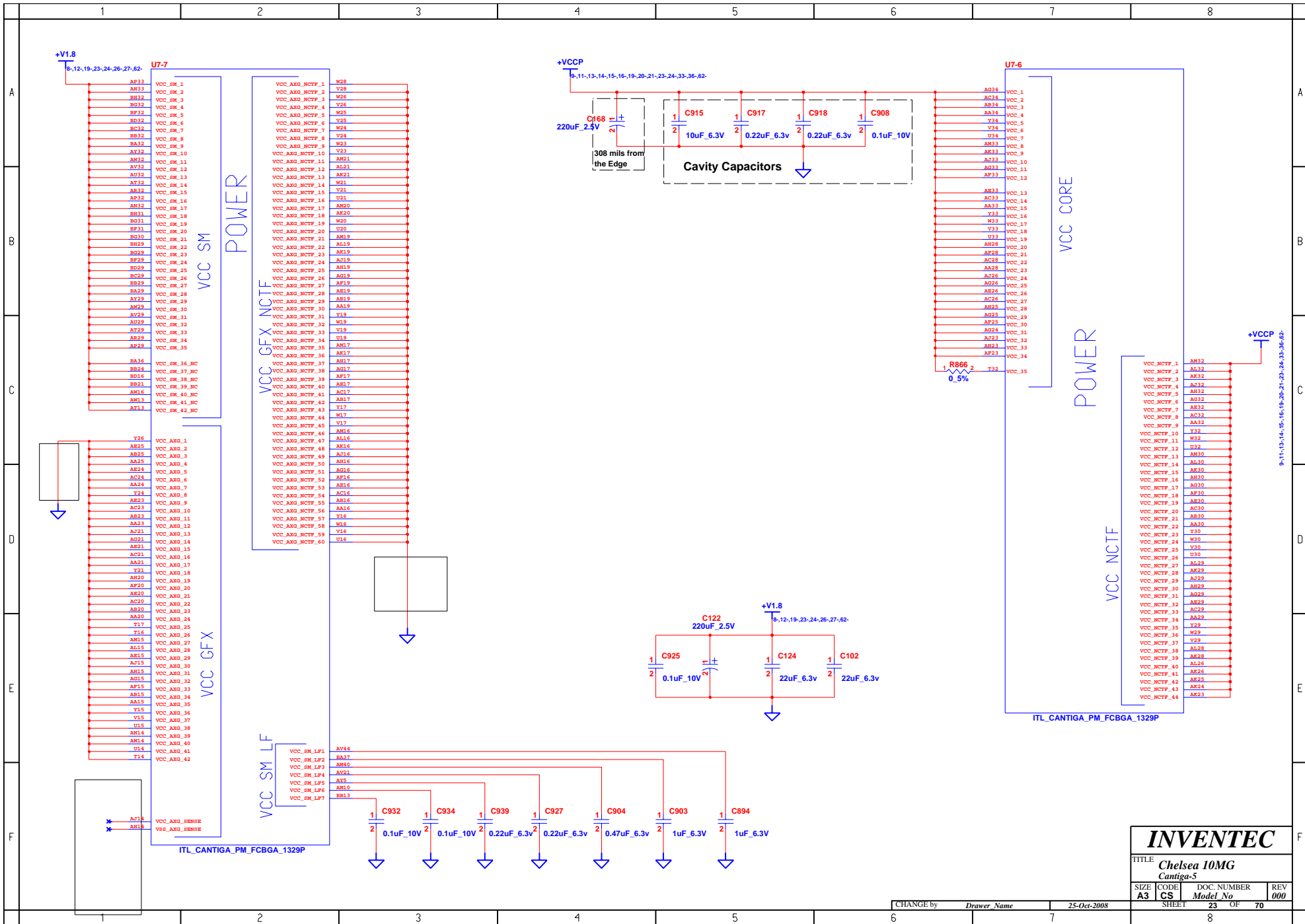

<b>INVENTEC</b>			
TITLE <i>Chelsea 10MG</i> Cantiga-5			
SIZE <b>A3</b>	CODE <b>CS</b>	DOC. NUMBER <i>Model No</i>	REV <b>000</b>
CHANGE by <i>Drawer Name</i>		25-Oct-2008	
SHEET <b>23</b>		OF <b>70</b>	

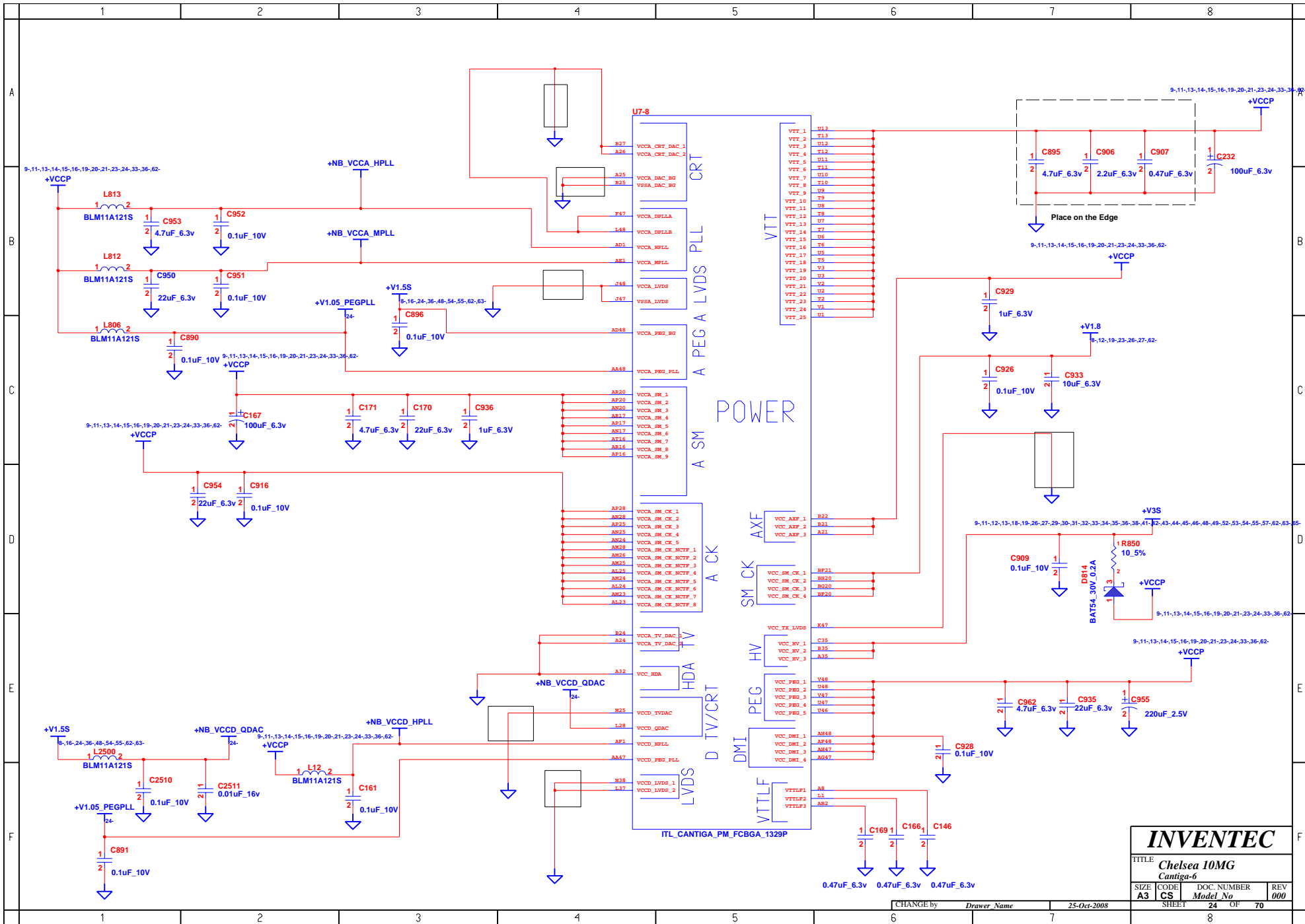

POWER

<b>INVENTEC</b>			
TITLE <i>Chelsea 10MG</i> Cantiga-6			
SIZE A3	CODE CS	DOC. NUMBER Model No	REV 000
CHANGE by Drawer Name		25-Oct-2008	
SHEET 24		OF 70	



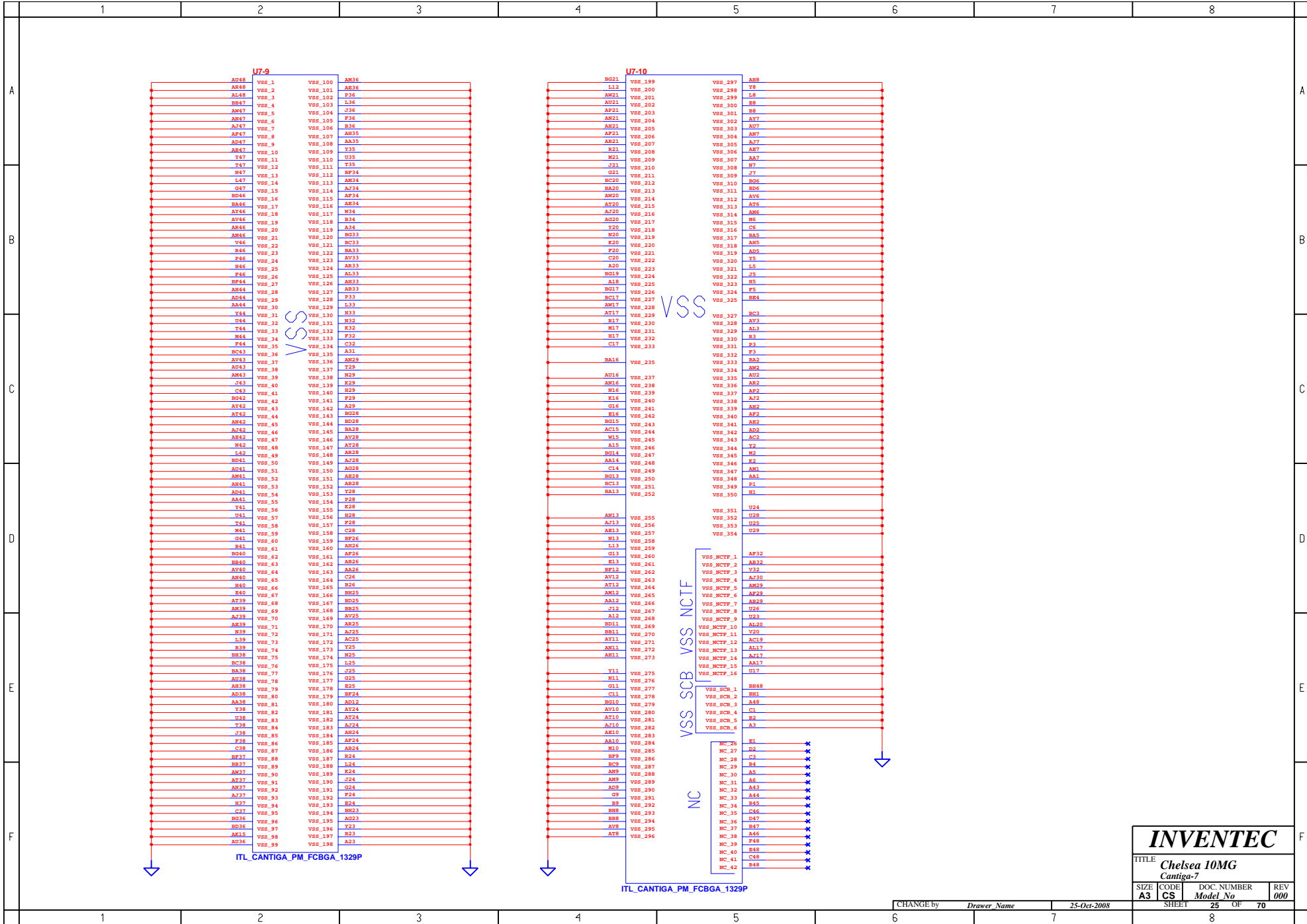

<b>INVENTEC</b>			
TITLE <i>Chelsea 10MG</i> Cantiga-7			
SIZE <b>A3</b>	CODE <b>CS</b>	DOC. NUMBER <i>Model No</i>	REV <b>000</b>
SHEET <b>25</b> OF <b>70</b>			

CHANGE by *Drawer Name* 25-Oct-2008

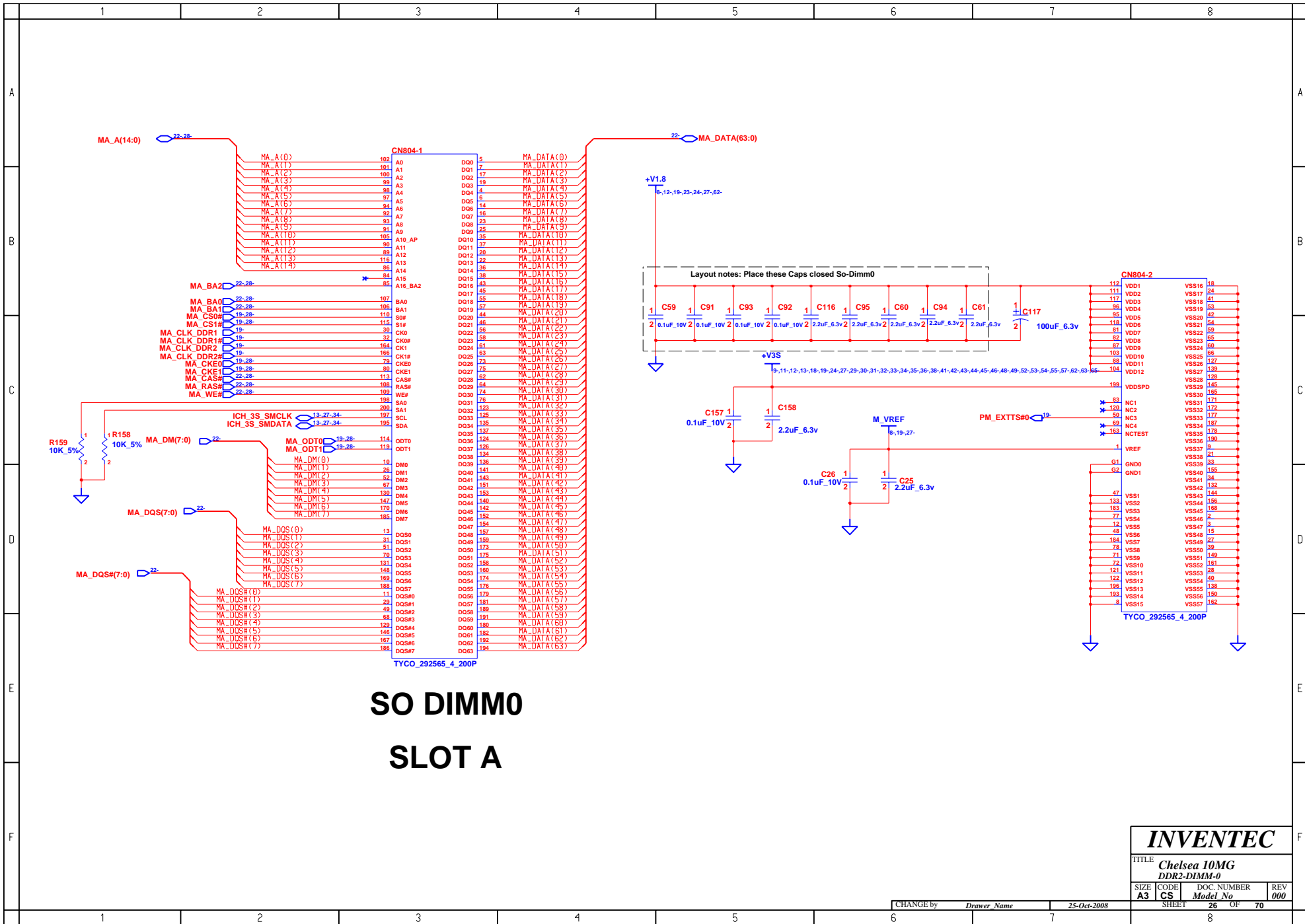

<b>INVENTEC</b>				
TITLE: <i>Chelsea 10MG</i>				
DDR2-DIMM-0				
SIZE	CODE	DOC. NUMBER	REV	
A3	CS	26	000	
CHANGE by		Drawer Name	25-Oct-2008	
SHEET		26		OF 70
		8		

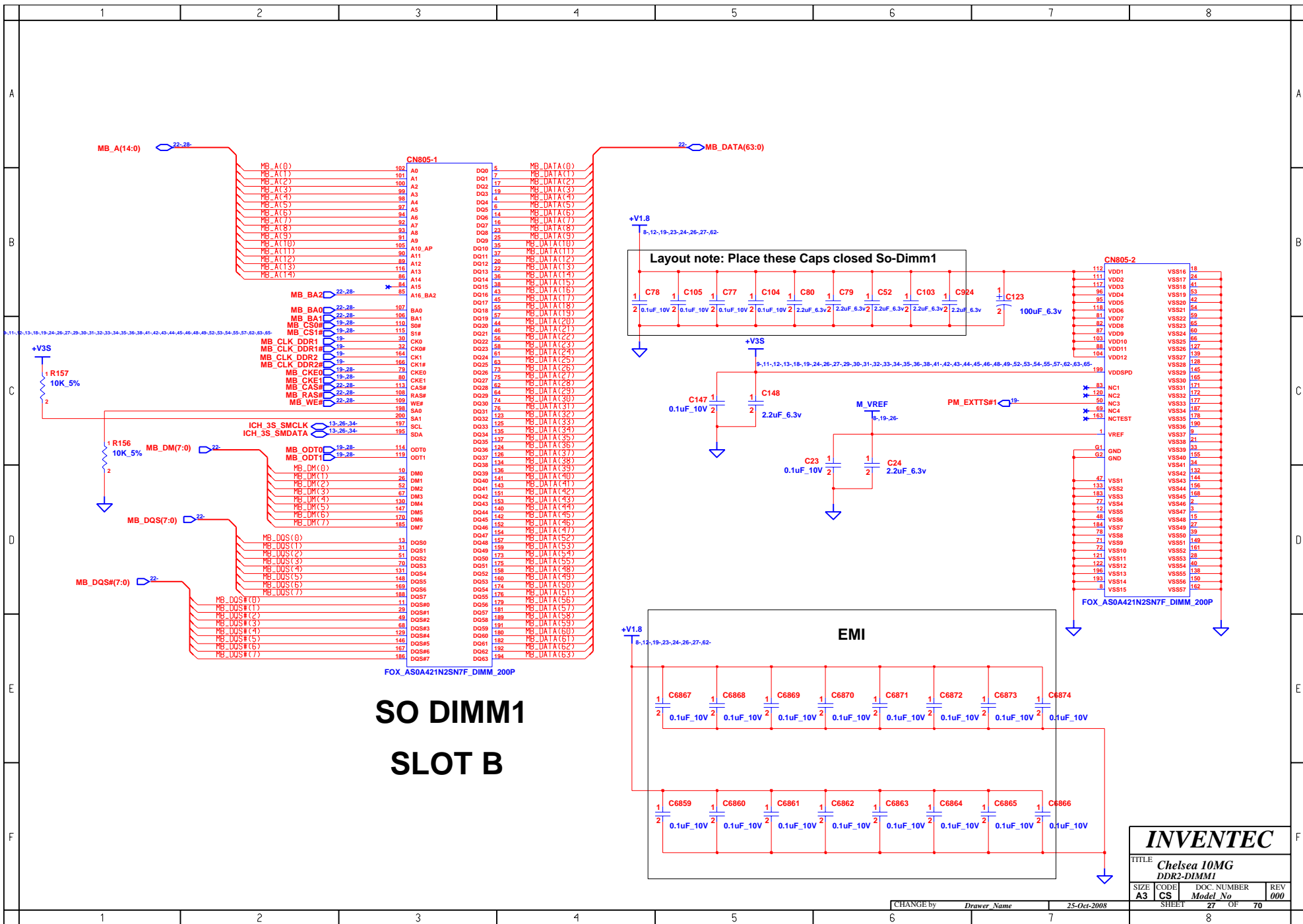

# SO DIMM1 SLOT B

## EMI

INVENTEC			
TITLE: <i>Chelsea 10MG DDR2-DIMM1</i>			
SIZE	CODE	DOC. NUMBER	REV
A3	CS	Model No	000
CHANGE by		Drawer Name	25-Oct-2008
SHEET		27	OF 70

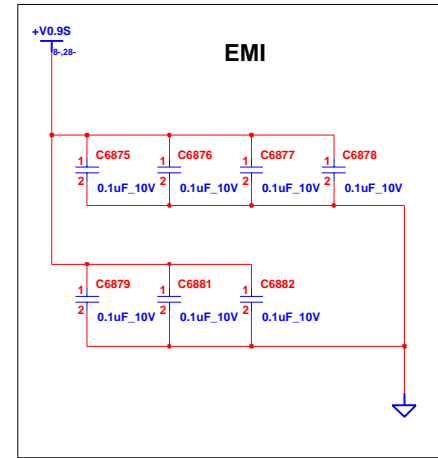
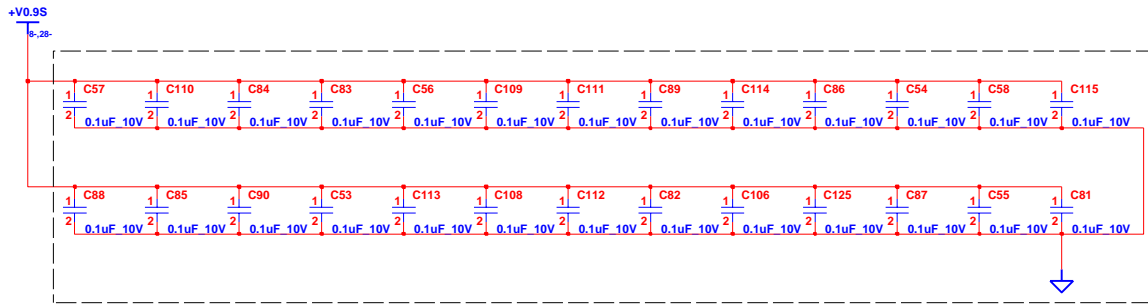

LAYOUT NOTES : PLACE ONE CAP CLOSE TO EVERY 2 PULL UP RESISTOR TERMINATED TO +V0.9S

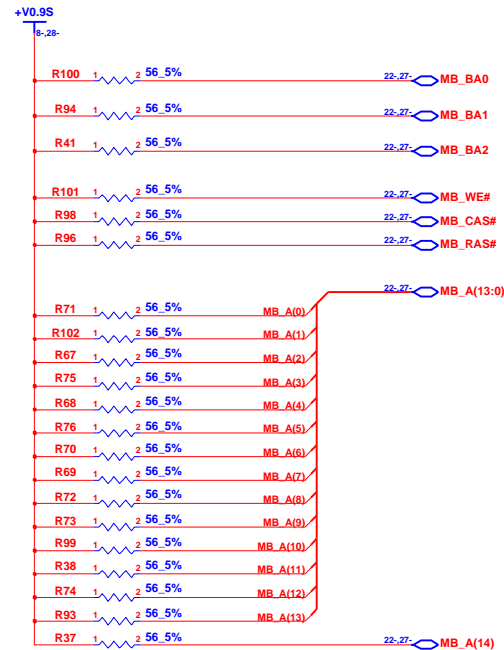
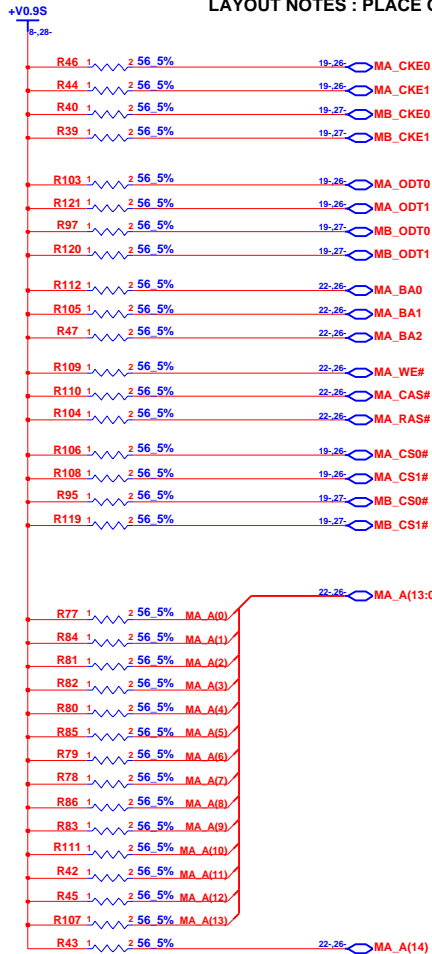

# INVENTEC

TITLE			
Chelsea 10MG			
DDR2-Damping			
SIZE	CODE	DOC NUMBER	REV
A3	CS	Model No	000

CHANGE by *Drawer Name* 27-Sep-2003

SHEET 28 OF 70

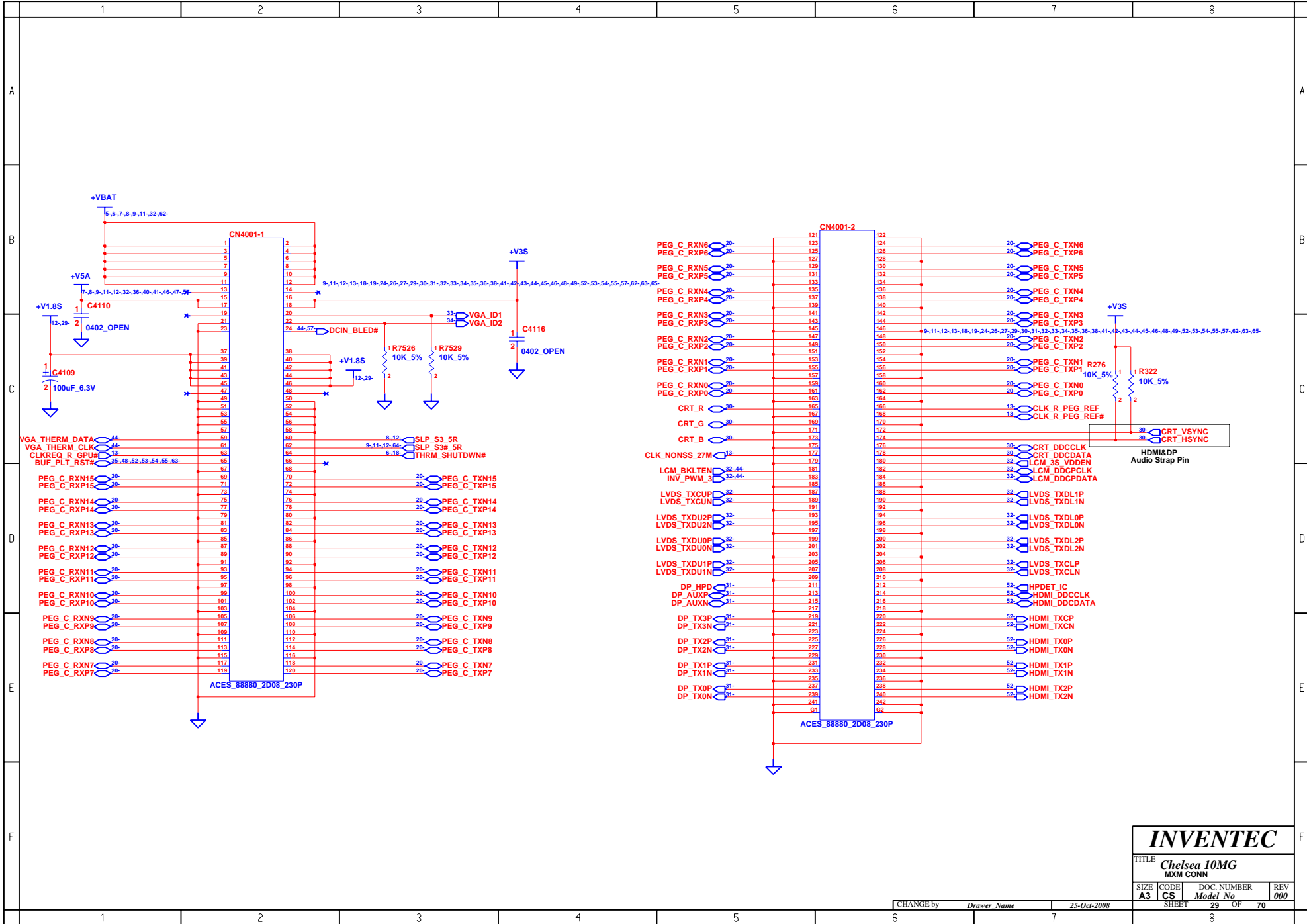

<b>INVENTEC</b>			
TITLE <i>Chelsea 10MG</i> MXM CONN			
SIZE <b>A3</b>	CODE <b>CS</b>	DOC. NUMBER <i>Model No</i>	REV <b>000</b>
CHANGE by <i>Drawer Name</i>		25-Oct-2008	
SHEET <b>29</b> OF <b>70</b>			

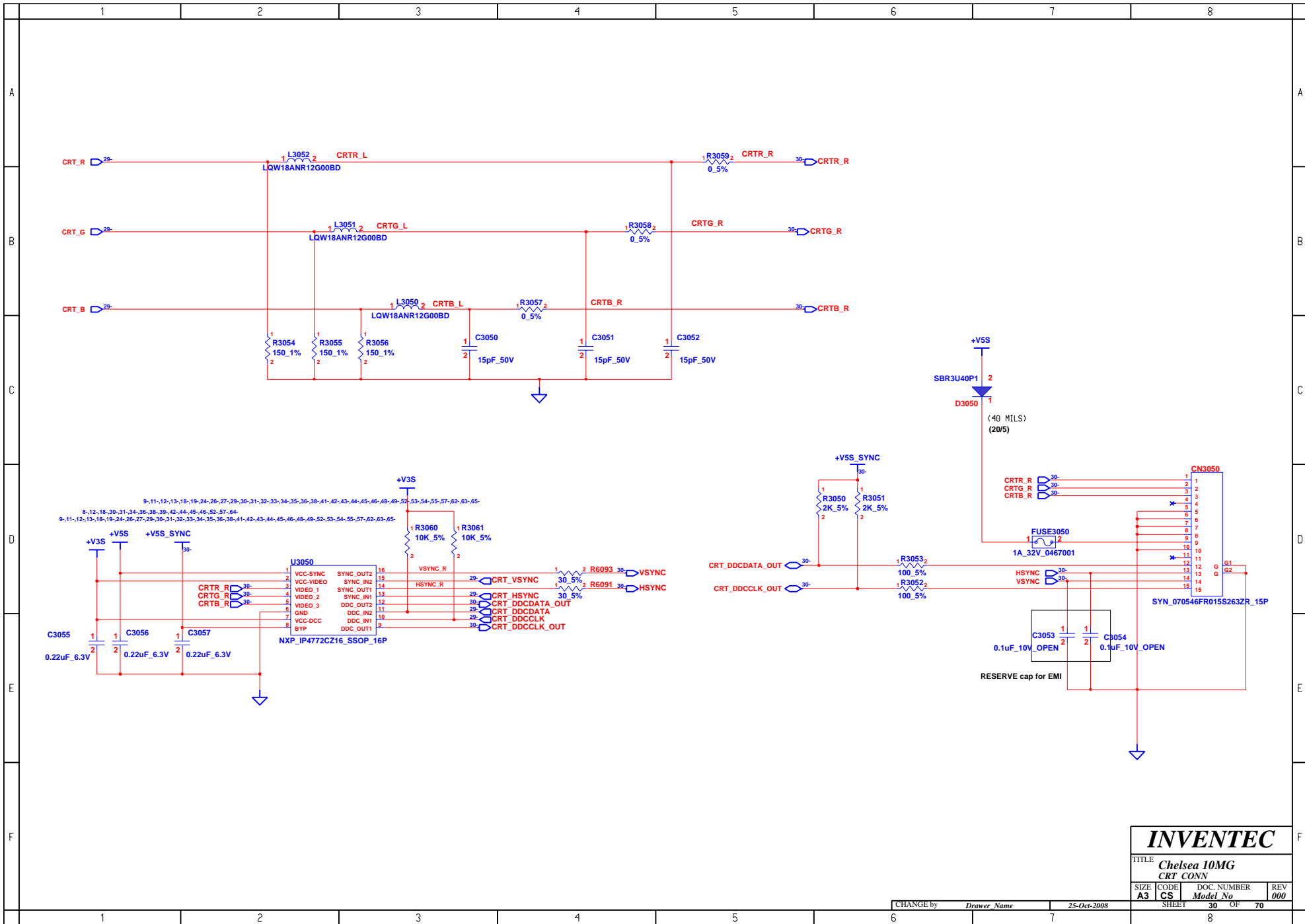

# INVENTEC

TITLE  
**Chelsea 10MG  
 CRT CONN**

SIZE <b>A3</b>	CODE <b>CS</b>	DOC. NUMBER <i>Model No</i>	REV <b>000</b>
-------------------	-------------------	--------------------------------	-------------------

CHANGE by *Drawer Name* 25-Oct-2008

SHEET **30** OF **70**

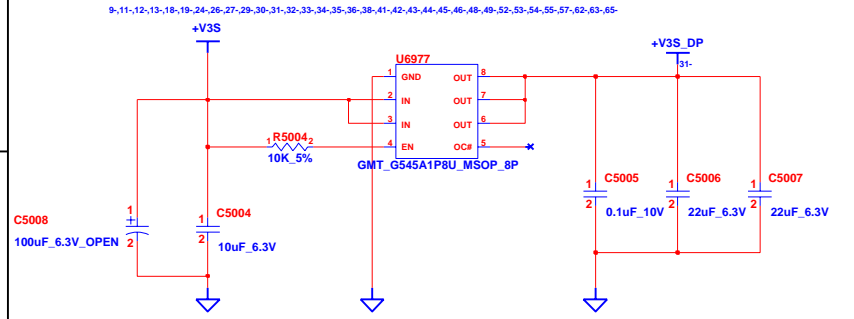
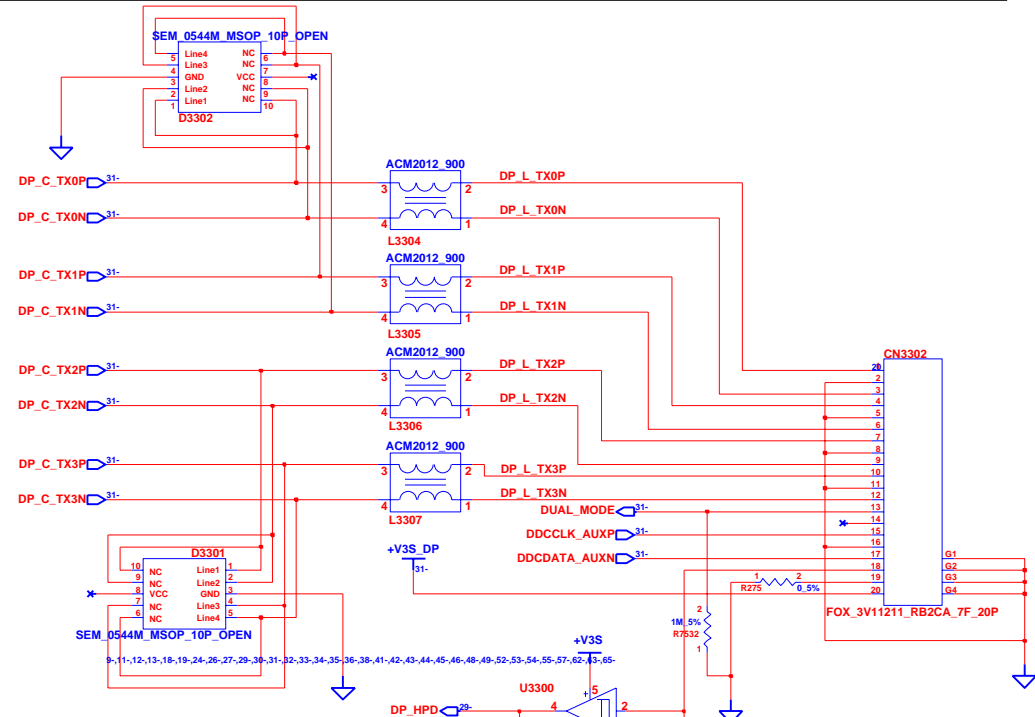
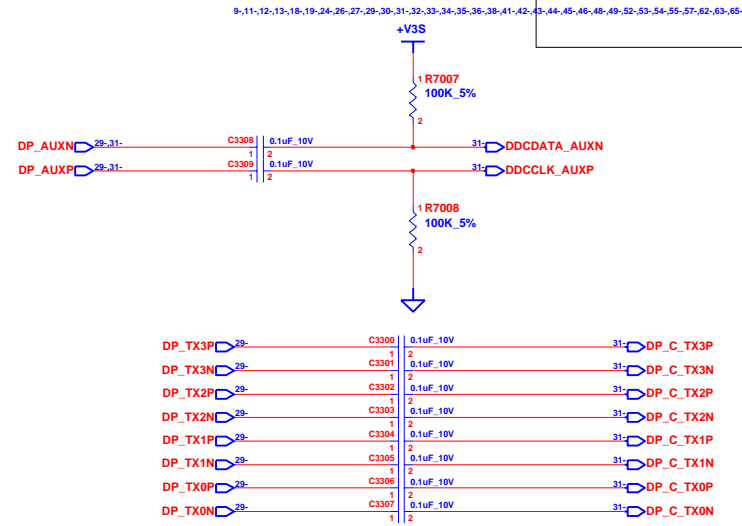
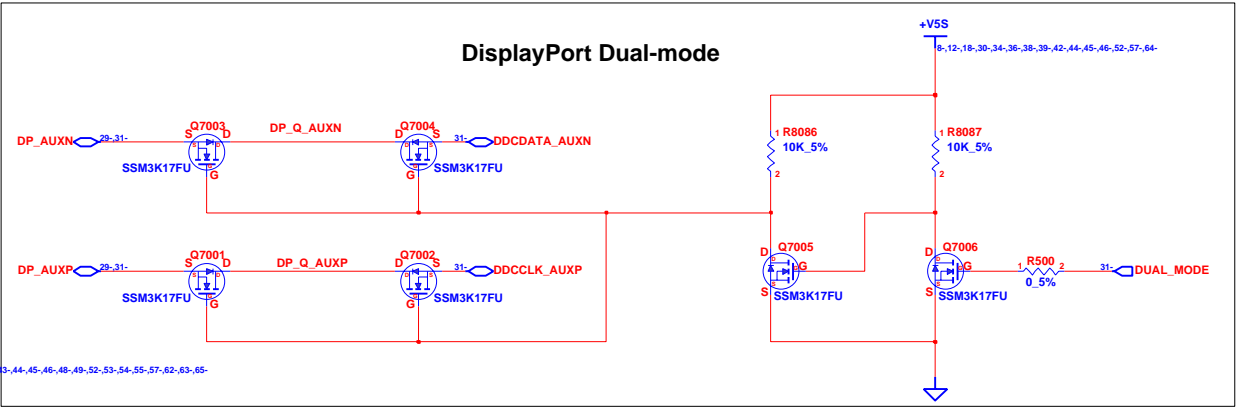

No DisplayPort : Stuff  
60130B1040ZT

<b>INVENTEC</b>			
TITLE <b>Chelsea 10MG DisplayPort</b>			
SIZE <b>A3</b>	CODE <b>CS</b>	DOC NUMBER <i>Model No</i>	REV <b>000</b>
CHANGE by <i>Drawer Name</i>		25-Oct-2008	
SHEET <b>31</b>		OF <b>70</b>	

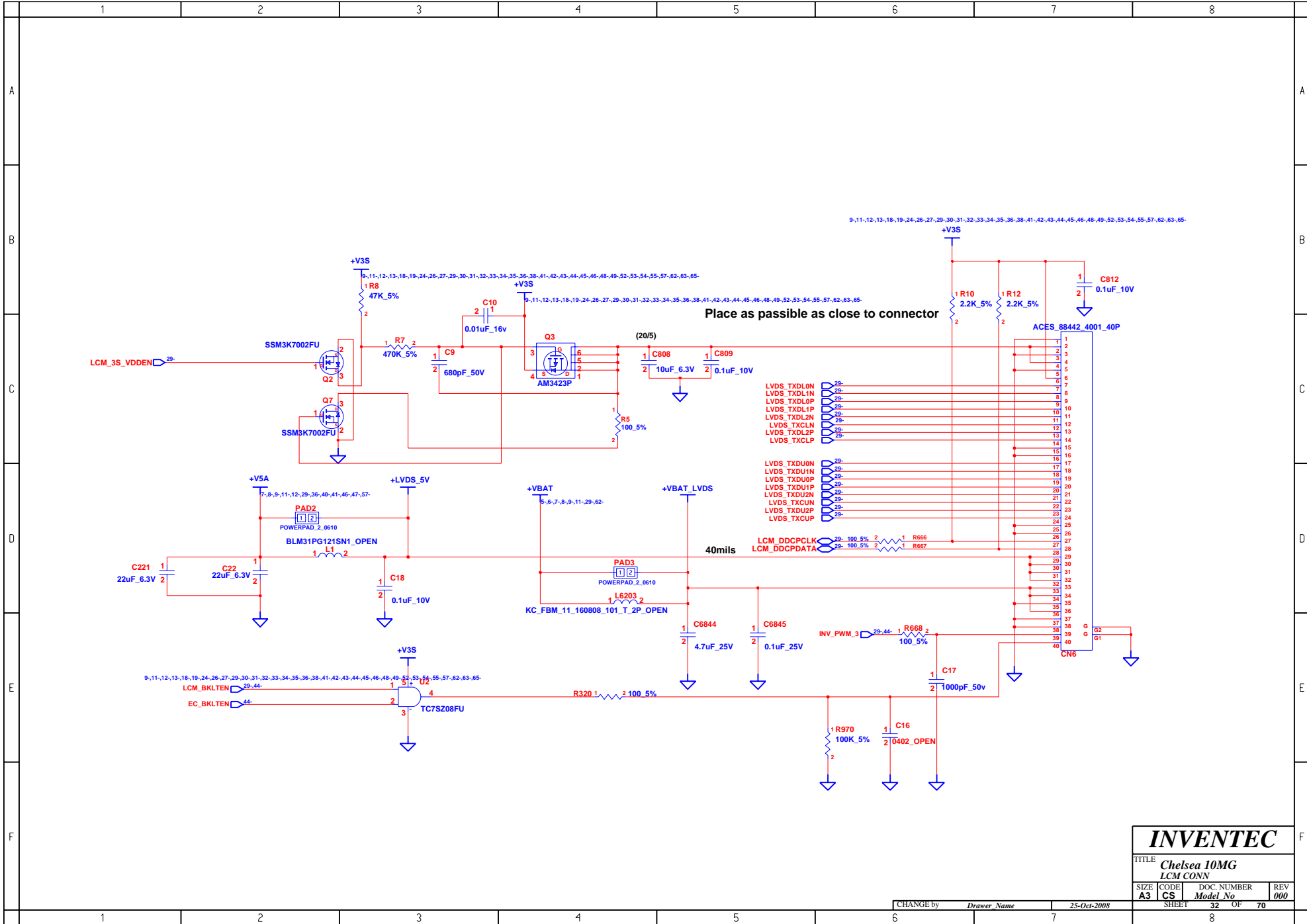

<b>INVENTEC</b>			
TITLE Chelsea 10MG LCM CONN			
SIZE A3	CODE CS	DOC. NUMBER Model No	REV 000
CHANGE by Drawer Name		25-Oct-2008	SHEET 32 OF 70



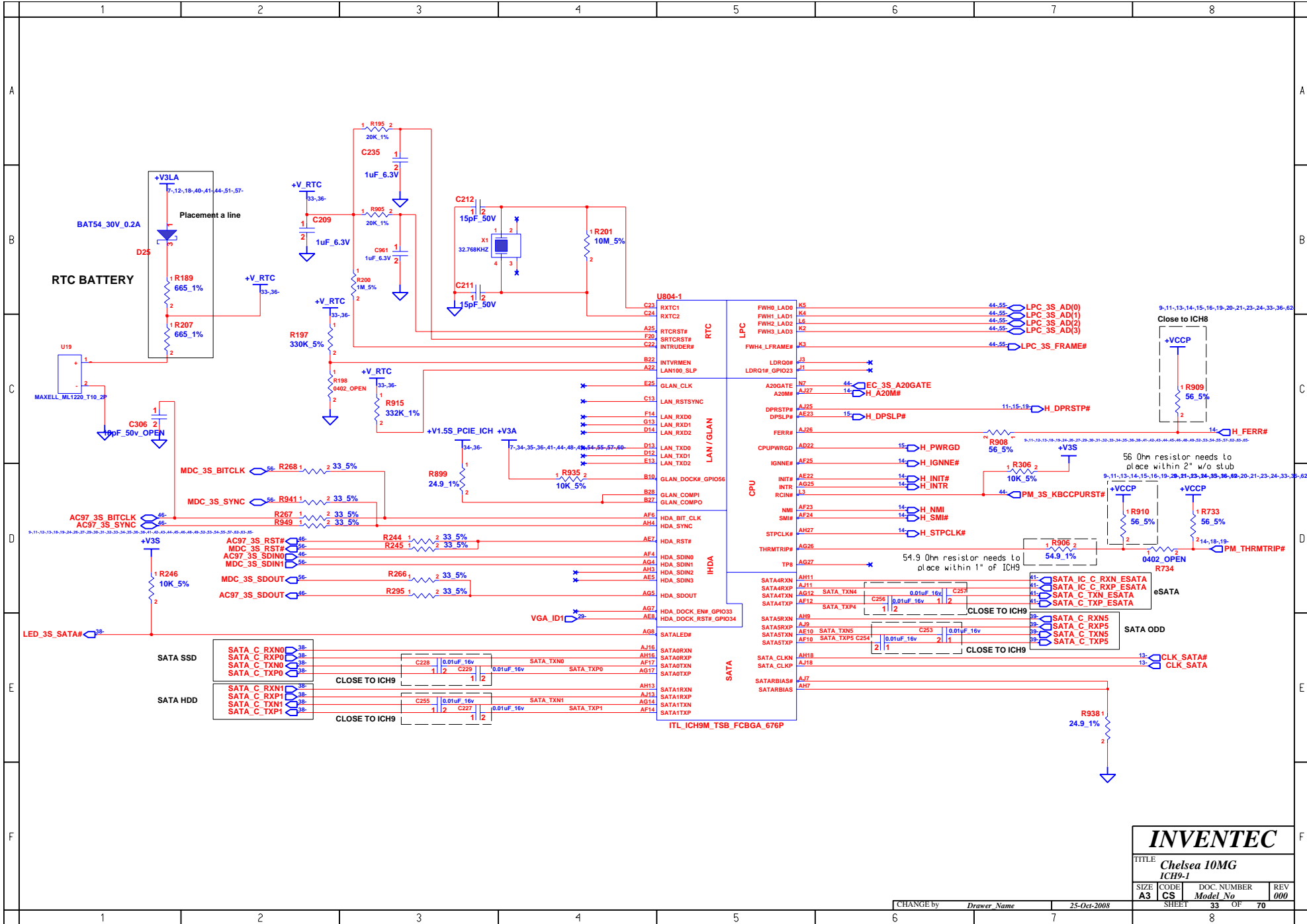

# INVENTEC

TITLE  
**Chelsea 10MG**  
**ICH9-1**

SIZE	CODE	DOC. NUMBER	REV
A3	CS	Model No	000

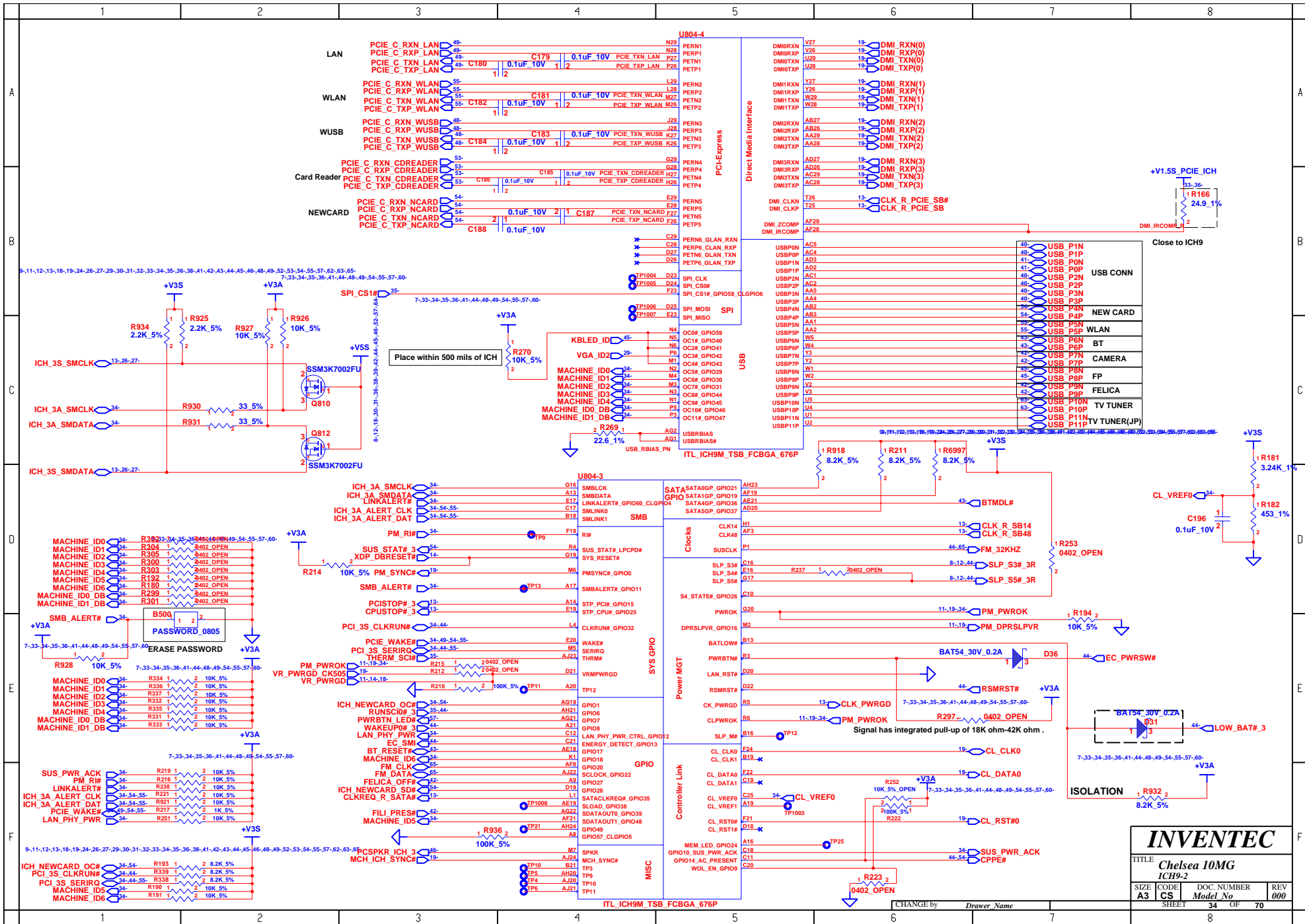

<b>INVENTEC</b>			
TITLE <b>Chelsea 10MG ICH9-2</b>			
SIZE <b>A3</b>	CODE <b>CS</b>	DOC. NUMBER	REV <b>000</b>
SHEET <b>34</b>		OF <b>70</b>	

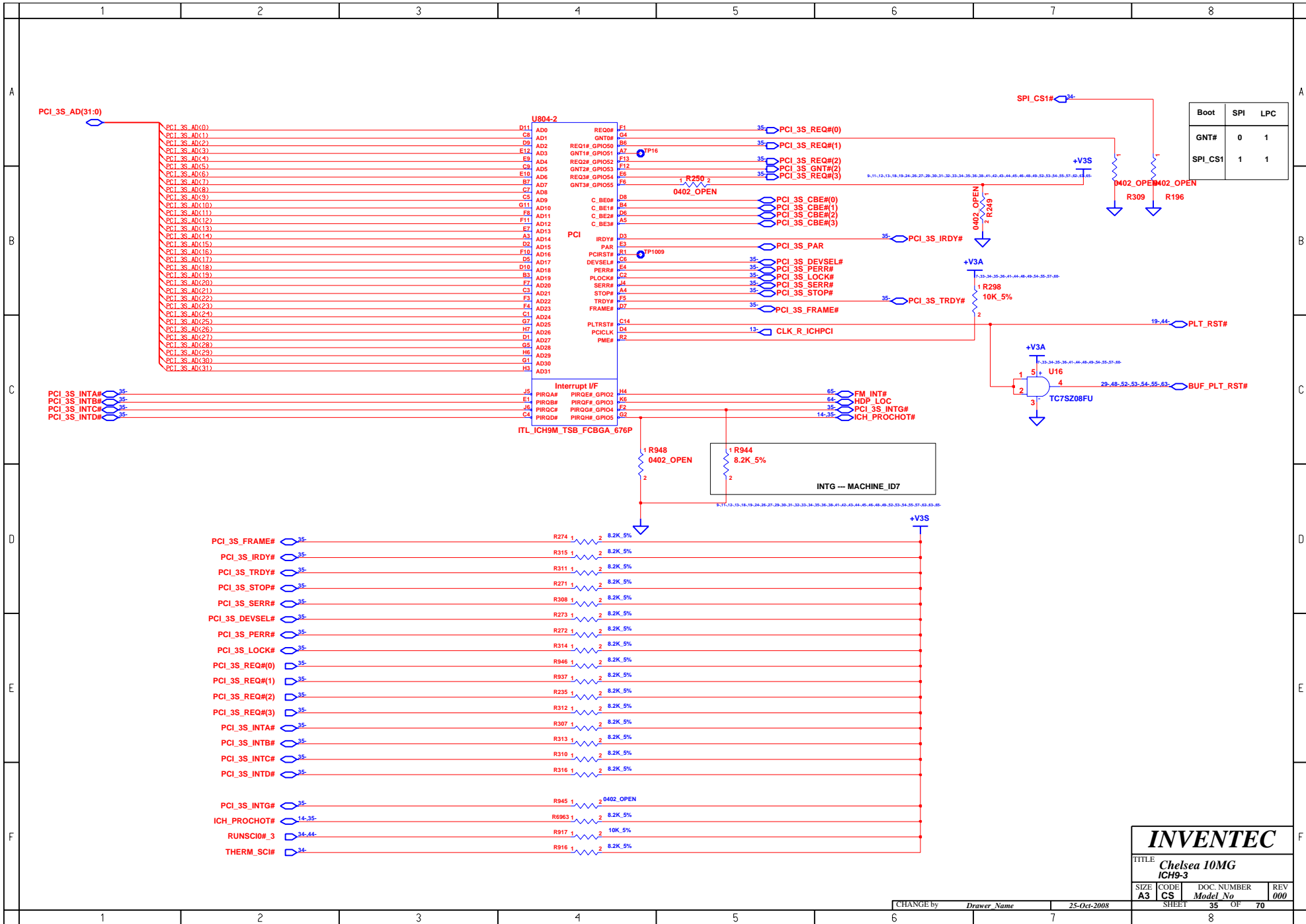

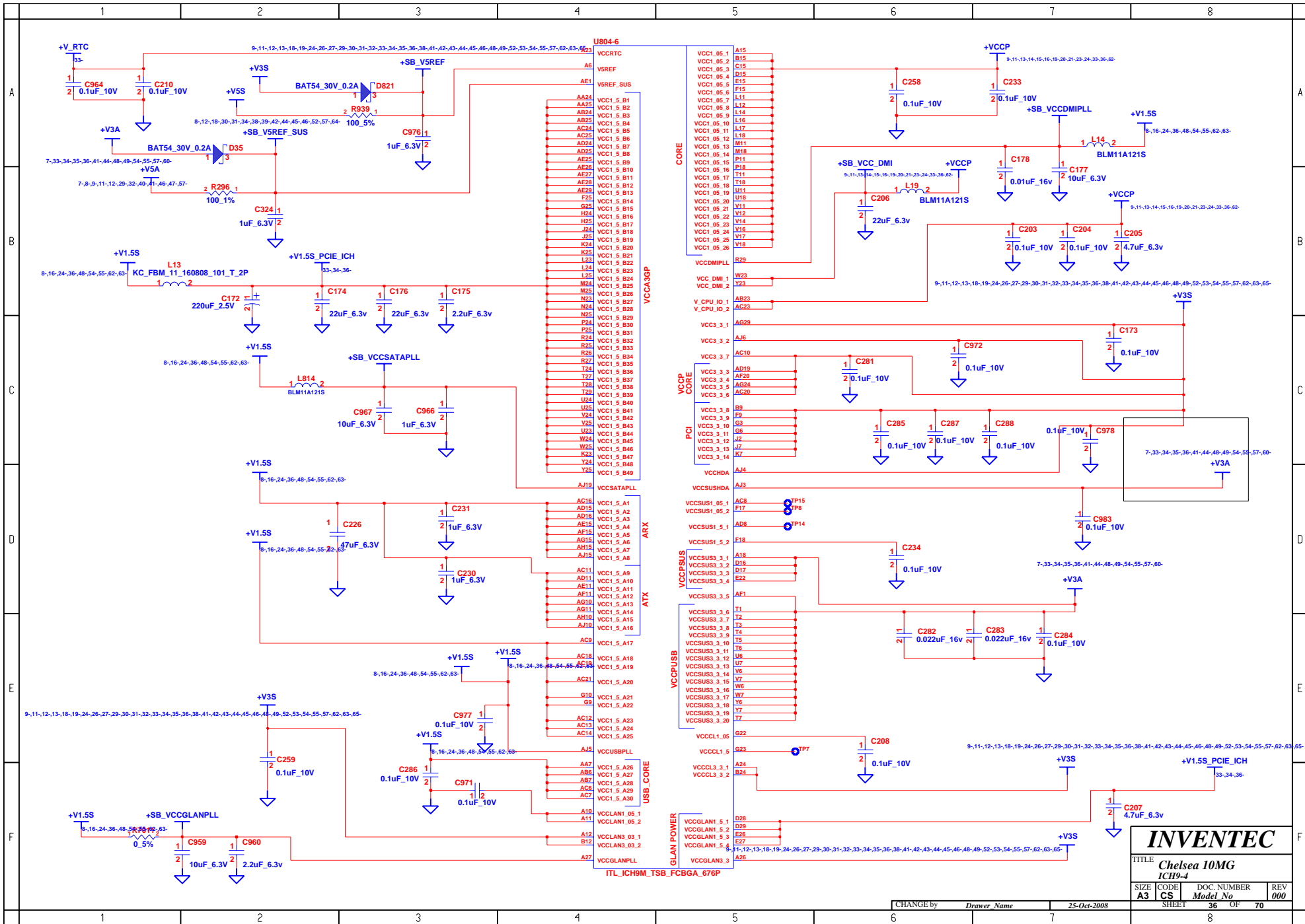

**INVENTEC**

TITLE: **Chelsea 10MG ICH9-4**

SIZE	CODE	DOC. NUMBER	REV
A3	CS	Model No	000

SHEET 36 OF 70

CHANGE by *Drawer Name* 25-Oct-2008

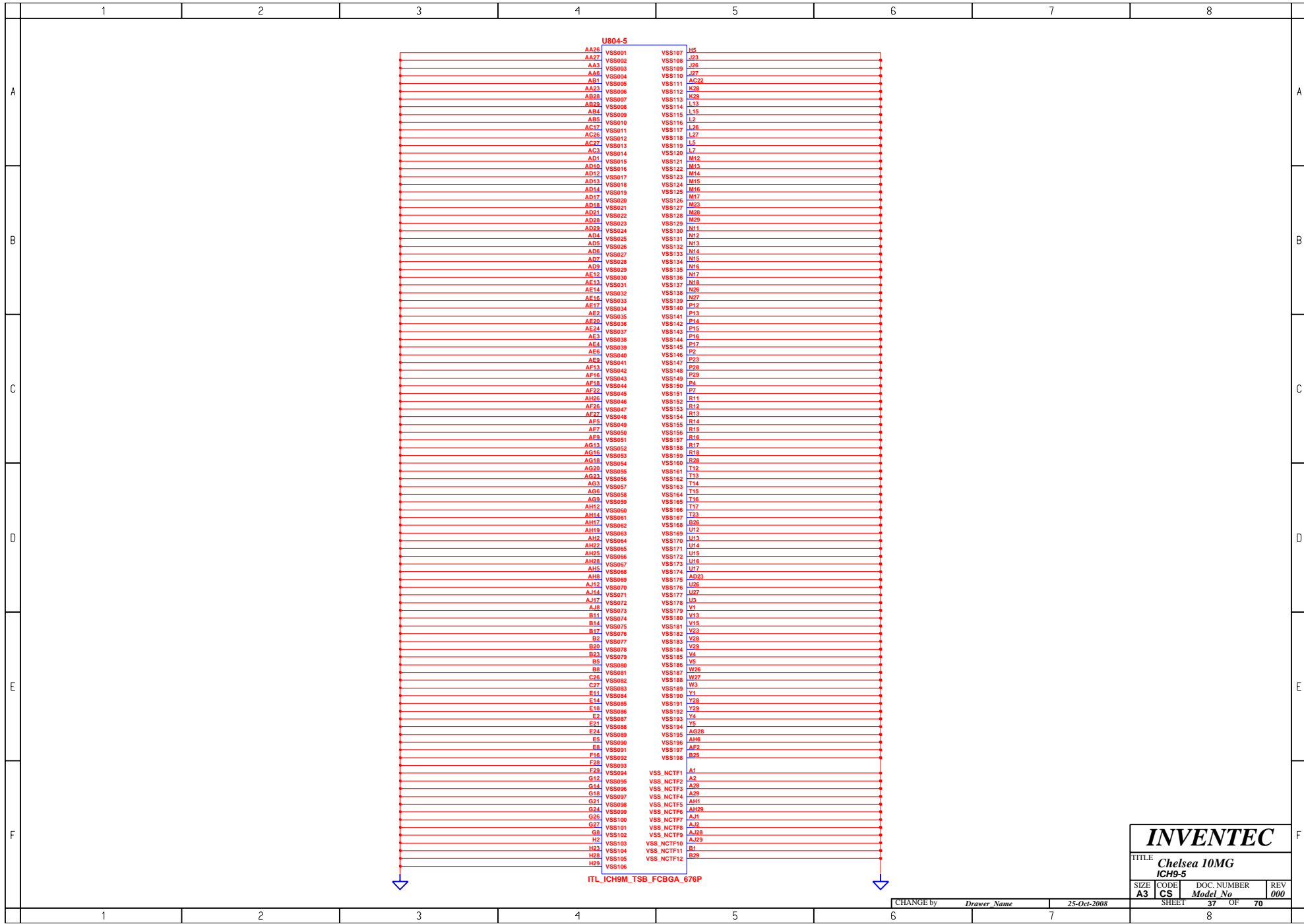

**U804-5**

AA26	VSS001	VSS107	H5
AA27	VSS002	VSS108	J23
AA3	VSS003	VSS109	J26
AA4	VSS004	VSS110	J27
AB1	VSS005	VSS111	AC22
AA23	VSS006	VSS112	K28
AB26	VSS007	VSS113	K29
AB28	VSS008	VSS114	L13
AB4	VSS009	VSS115	L15
AB5	VSS010	VSS116	L2
AC17	VSS011	VSS117	L26
AC26	VSS012	VSS118	L27
AC27	VSS013	VSS119	L5
AC3	VSS014	VSS120	L7
AD1	VSS015	VSS121	M12
AD10	VSS016	VSS122	M13
AD12	VSS017	VSS123	M14
AD13	VSS018	VSS124	M15
AD14	VSS019	VSS125	M16
AD17	VSS020	VSS126	M17
AD18	VSS021	VSS127	M23
AD21	VSS022	VSS128	M28
AD26	VSS023	VSS129	M29
AD29	VSS024	VSS130	N11
AD4	VSS025	VSS131	N12
AD6	VSS026	VSS132	N13
AD6	VSS027	VSS133	N14
AD7	VSS028	VSS134	N15
AD9	VSS029	VSS135	N16
AE13	VSS030	VSS136	N17
AE13	VSS031	VSS137	N18
AE14	VSS032	VSS138	N26
AE16	VSS033	VSS139	N27
AE17	VSS034	VSS140	P12
AE1	VSS035	VSS141	P13
AE20	VSS036	VSS142	P14
AE24	VSS037	VSS143	P15
AE3	VSS038	VSS144	P16
AE4	VSS039	VSS145	P17
AE6	VSS040	VSS146	P2
AE9	VSS041	VSS147	P23
AF13	VSS042	VSS148	P28
AF16	VSS043	VSS149	P29
AF18	VSS044	VSS150	P4
AF26	VSS045	VSS151	P7
AH26	VSS046	VSS152	R11
AF26	VSS047	VSS153	R12
AF27	VSS048	VSS154	R13
AF3	VSS049	VSS155	R14
AF7	VSS050	VSS156	R15
AF9	VSS051	VSS157	R16
AG13	VSS052	VSS158	R17
AG16	VSS053	VSS159	R18
AG18	VSS054	VSS160	R28
AG20	VSS055	VSS161	T12
AG23	VSS056	VSS162	T13
AG3	VSS057	VSS163	T14
AG6	VSS058	VSS164	T15
AG9	VSS059	VSS165	T16
AH12	VSS060	VSS166	T17
AH14	VSS061	VSS167	T23
AH17	VSS062	VSS168	B26
AH19	VSS063	VSS169	U12
AH2	VSS064	VSS170	U13
AH22	VSS065	VSS171	U14
AH26	VSS066	VSS172	U15
AH28	VSS067	VSS173	U16
AH6	VSS068	VSS174	U17
AH6	VSS069	VSS175	AD23
AJ12	VSS070	VSS176	U26
AJ14	VSS071	VSS177	U27
AJ17	VSS072	VSS178	U3
AJ8	VSS073	VSS179	V1
B11	VSS074	VSS180	V13
B14	VSS075	VSS181	V15
B17	VSS076	VSS182	V23
B1	VSS077	VSS183	V28
B20	VSS078	VSS184	V29
B23	VSS079	VSS185	V4
B5	VSS080	VSS186	V5
B6	VSS081	VSS187	W26
C26	VSS082	VSS188	W27
C27	VSS083	VSS189	W3
E11	VSS084	VSS190	Y1
E14	VSS085	VSS191	Y28
E18	VSS086	VSS192	Y29
ER	VSS087	VSS193	Y4
E21	VSS088	VSS194	Y5
E24	VSS089	VSS195	AG28
E5	VSS090	VSS196	AH6
ER	VSS091	VSS197	AF2
F16	VSS092	VSS198	B26
F29	VSS093		
F29	VSS094	VSS_NCTF1	A1
G12	VSS095	VSS_NCTF2	A2
G14	VSS096	VSS_NCTF3	A28
G19	VSS097	VSS_NCTF4	A29
G21	VSS098	VSS_NCTF5	AH1
G26	VSS099	VSS_NCTF6	AH29
G26	VSS100	VSS_NCTF7	AJ1
G27	VSS101	VSS_NCTF8	AJ2
GB	VSS102	VSS_NCTF9	AJ28
H3	VSS103	VSS_NCTF10	AJ29
H26	VSS104	VSS_NCTF11	B1
H28	VSS105	VSS_NCTF12	B29
H29	VSS106		

ITL\_ICH9M\_TSB\_FCBGA\_676P

**INVENTEC**

TITLE **Chelsea 10MG ICH9-5**

SIZE	CODE	DOC. NUMBER	REV
A3	CS	Model No	000

CHANGE by *Drawer Name* 25-Oct-2008 SHEET 37 OF 70

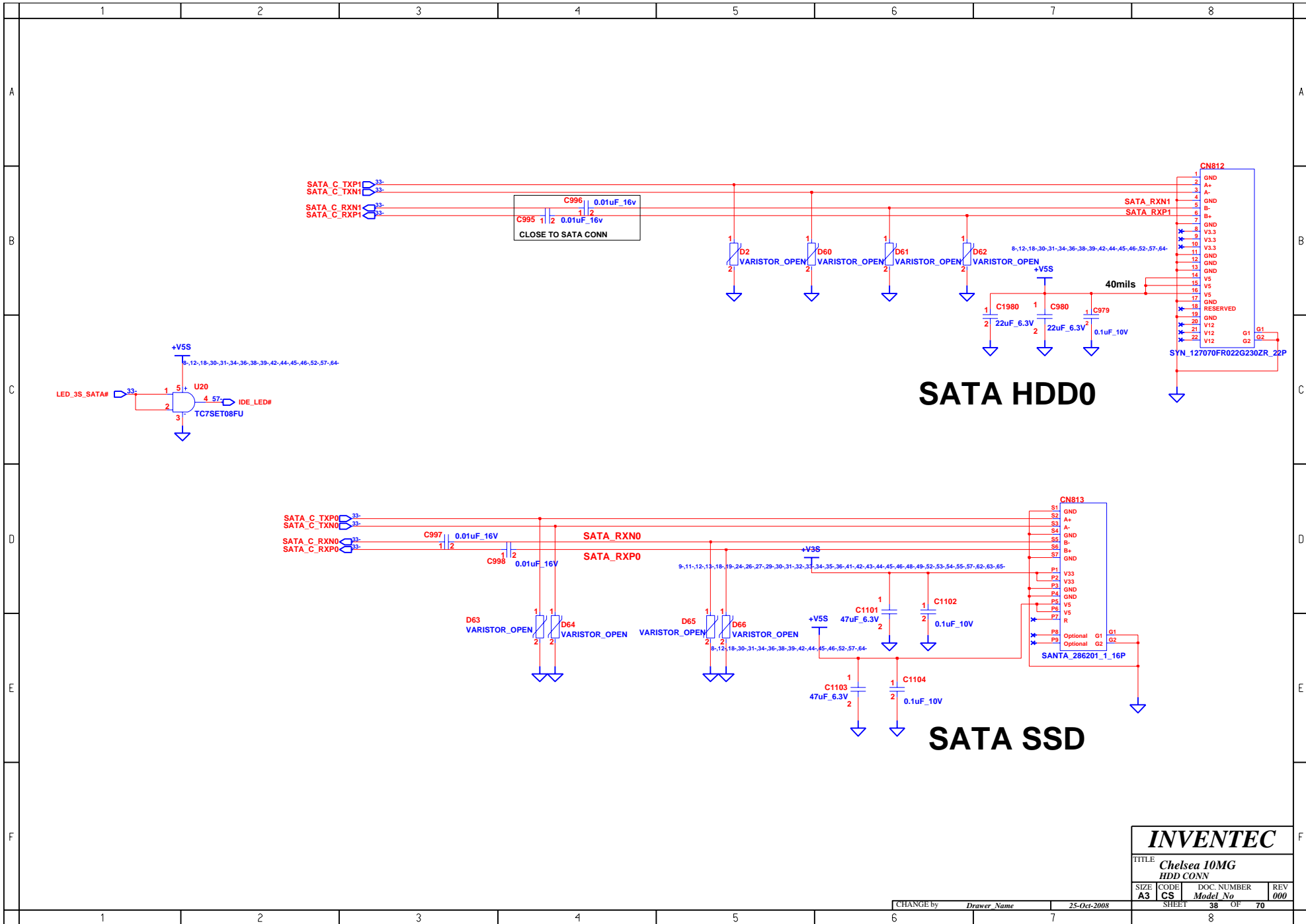

# SATA HDD0

# SATA SSD

<b>INVENTEC</b>			
TITLE <b>Chelsea 10MG HDD CONN</b>			
SIZE <b>A3</b>	CODE <b>CS</b>	DOC. NUMBER <i>Model No</i>	REV <b>000</b>
CHANGE by <i>Drawer Name</i>		25-Oct-2008	SHEET <b>38</b> OF <b>70</b>

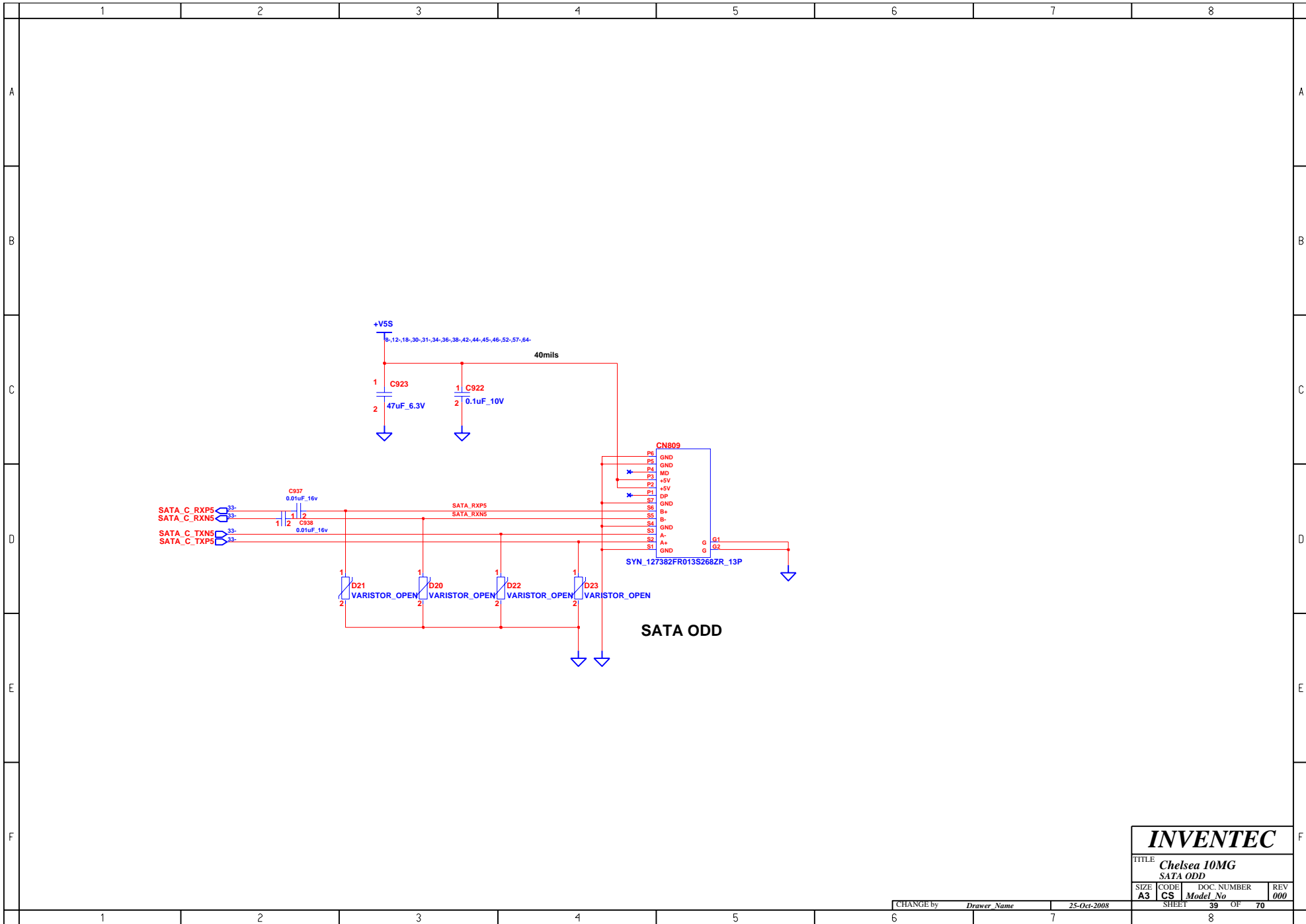

<b>INVENTEC</b>			
TITLE <b>Chelsea 10MG SATA ODD</b>			
SIZE <b>A3</b>	CODE <b>CS</b>	DOC. NUMBER <i>Model No</i>	REV <b>000</b>
CHANGE by <i>Drawer Name</i>		25-Oct-2008	SHEET <b>39</b> OF <b>70</b>

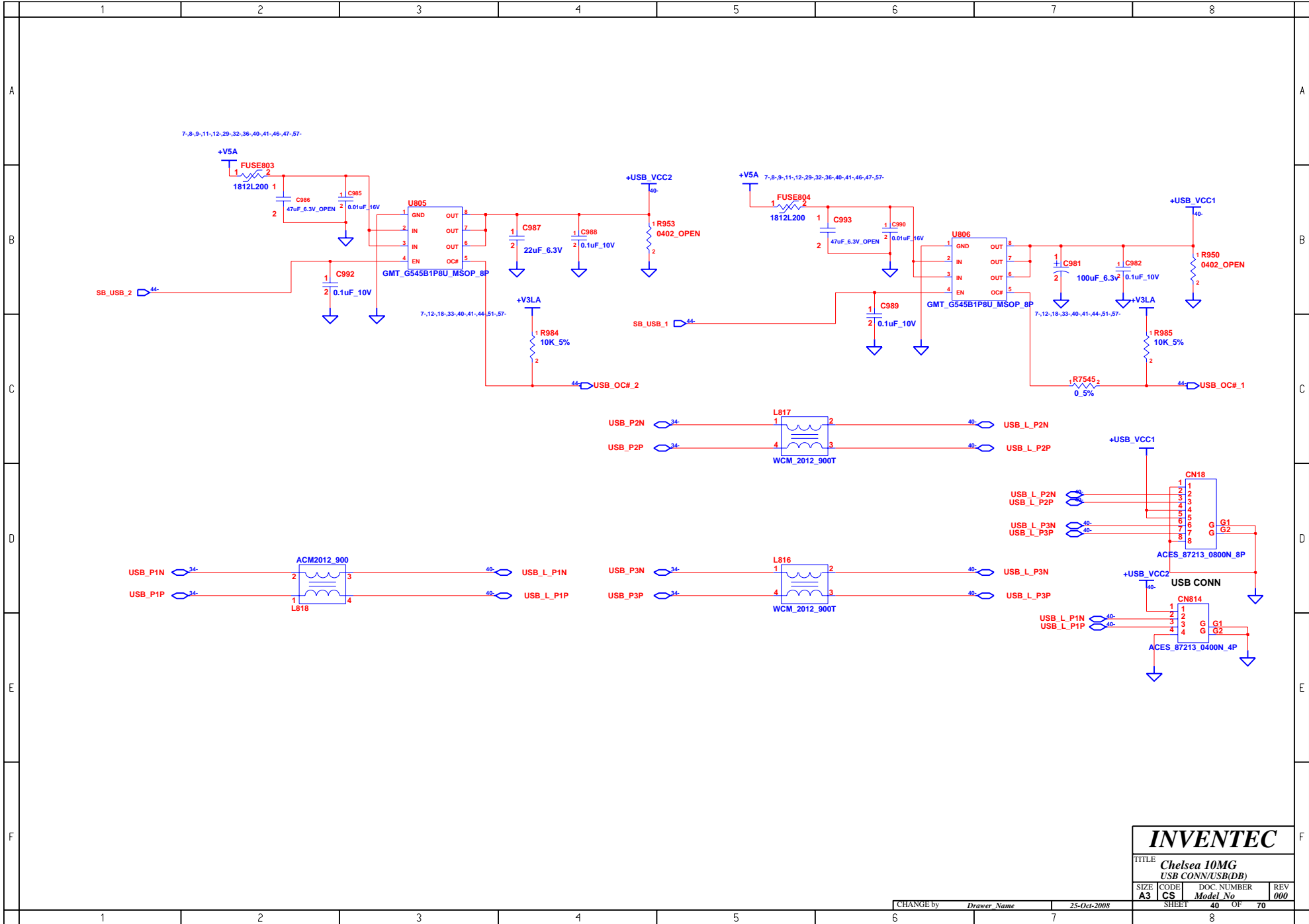

<b>INVENTEC</b>			
TITLE <i>Chelsea 10MG</i> USB CONN/USB(DB)			
SIZE <b>A3</b>	CODE <b>CS</b>	DOC. NUMBER Model No	REV <b>000</b>
CHANGE by <i>Drawer Name</i>		25-Oct-2008	SHEET <b>40</b> OF <b>70</b>



# E-SATA

ICH9

SATARXN  
SATARXP  
SATATXN  
SATATXP

## CLOSE TO IC PINS

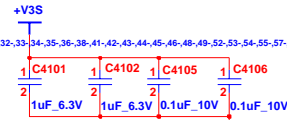

EN	D0	D1	FUNCTION
0	X	X	STANDBY
1	0	0	DEFAULT
1	1	0	CH0->5DB
1	0	1	CH1->5DB
1	1	1	CH0,1->5DB

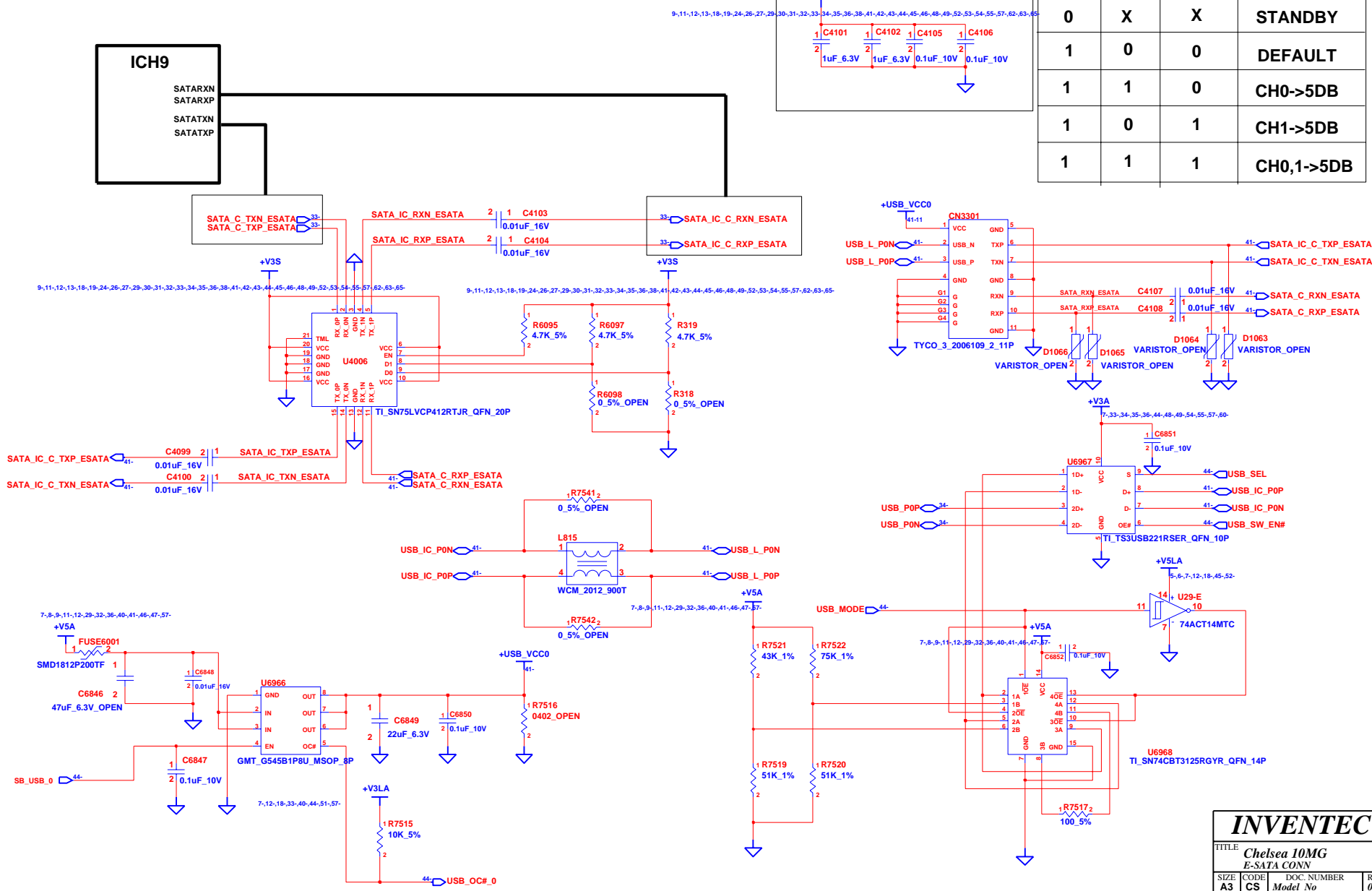

**INVENTEC**

TITLE Chelsea 10MG E-SATA CONN			
SIZE A3	CODE CS	DOC NUMBER Model No	REV 000
CHANGE by Drawer Name		25-Oct-2008	
SHEET 41		OF 70	

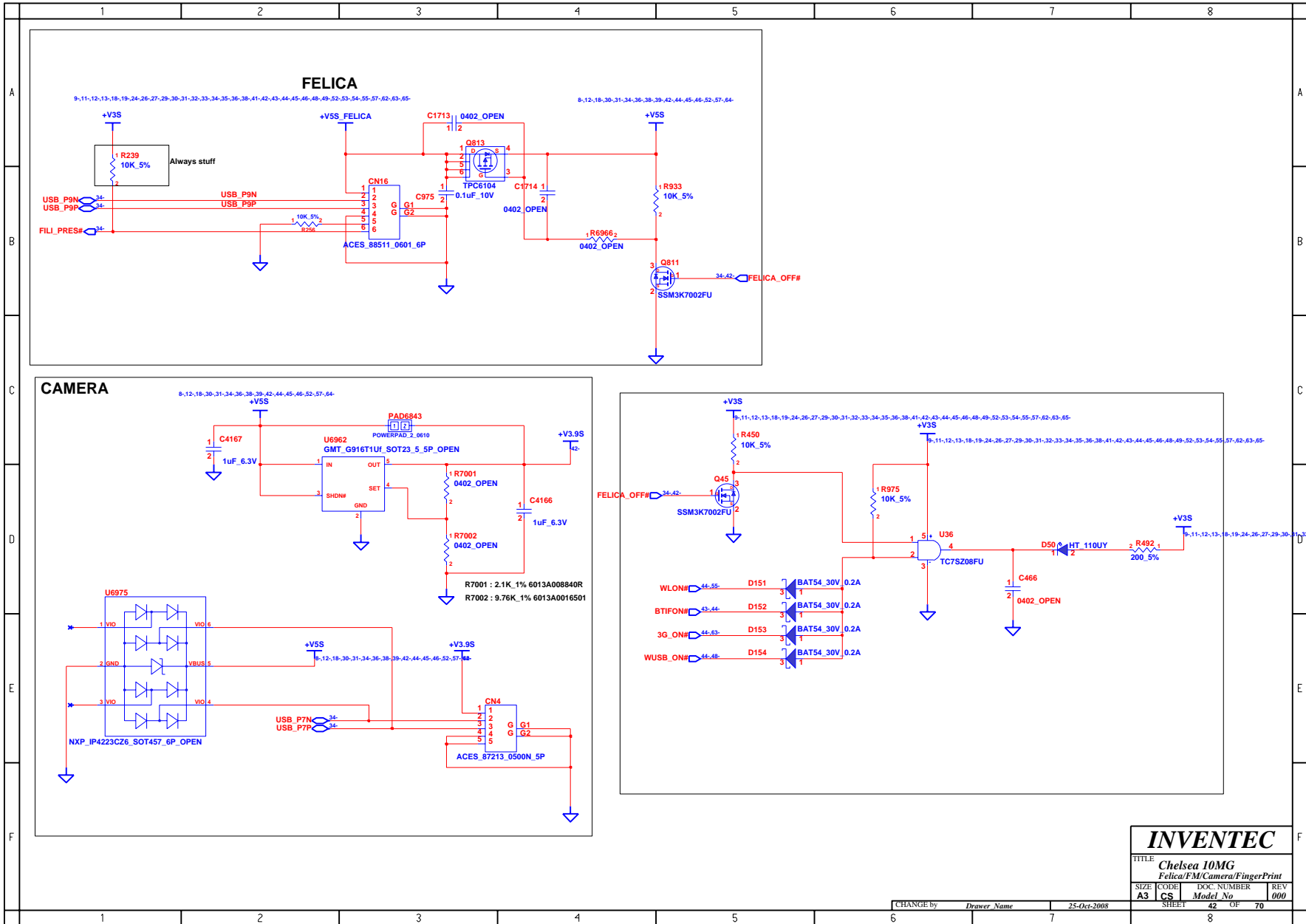

<b>INVENTEC</b>			
TITLE <i>Chelsea 10MG Felica/FM/Camera/FingerPrint</i>			
SIZE	CODE	DOC. NUMBER	REV
A3	CS	Model No	000
CHANGE by		25-Oct-2008	SHEET 42 OF 70

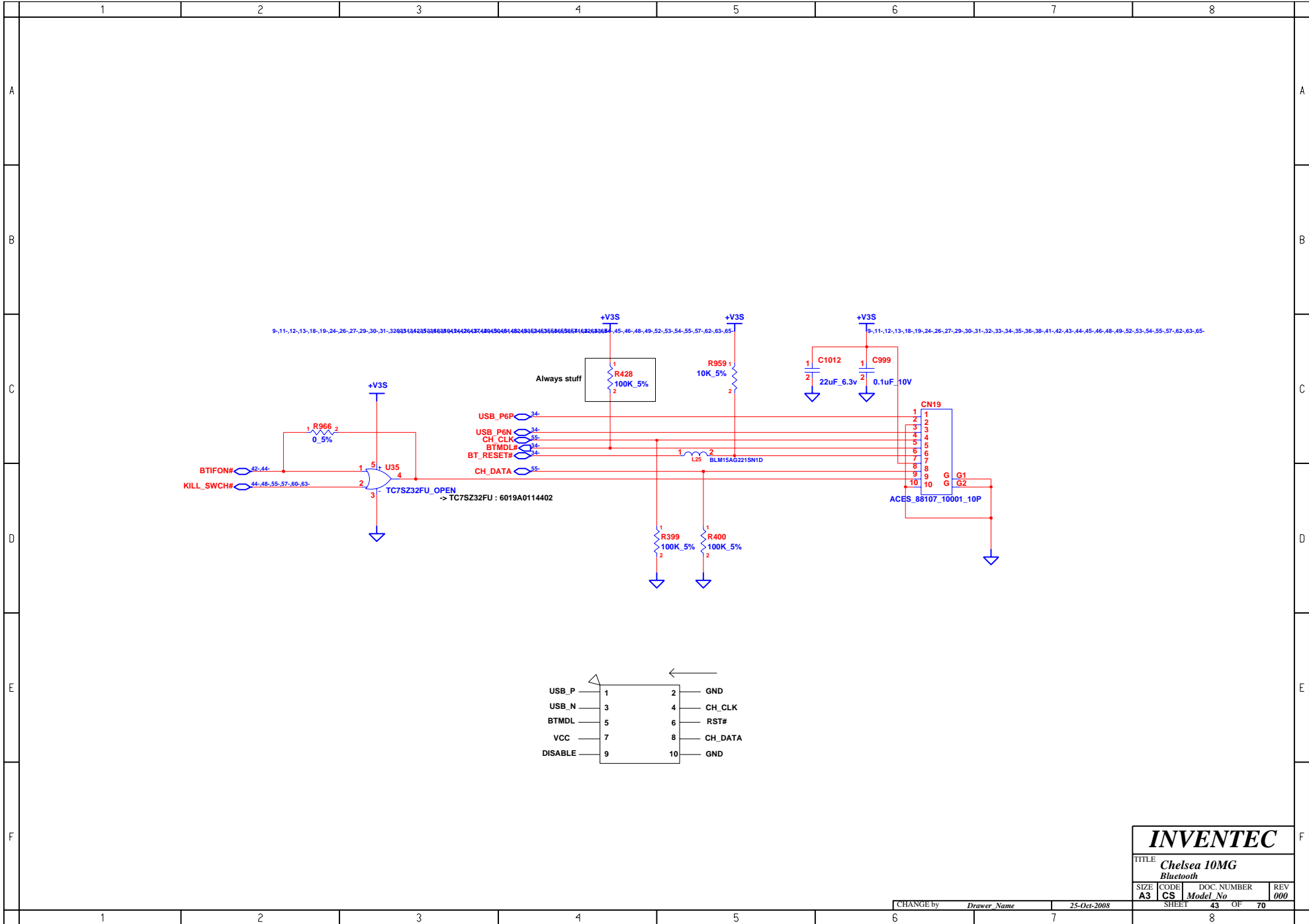

**INVENTEC**

TITLE  
**Chelsea 10MG**  
 Bluetooth

SIZE <b>A3</b>	CODE <b>CS</b>	DOC. NUMBER <i>Model No</i>	REV <b>000</b>
CHANGE by <i>Drawer Name</i>		25-Oct-2008	
SHEET <b>43</b>		OF <b>70</b>	

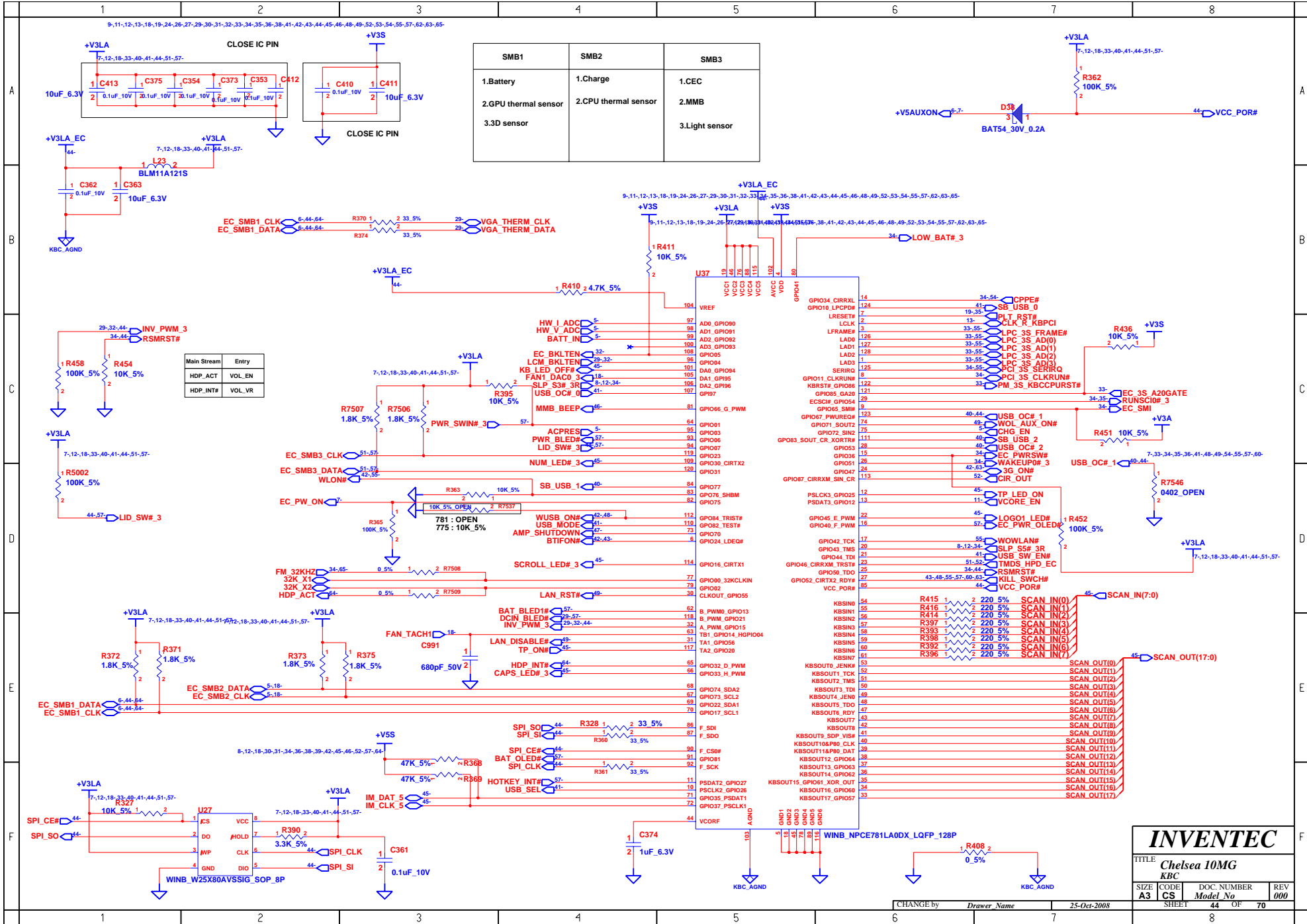

SMB1	SMB2	SMB3
1. Battery	1. Charge	1. CEC
2. GPU thermal sensor	2. CPU thermal sensor	2. MMB
3. 3D sensor		3. Light sensor

Main Stream	Entry
HDP_ACT	VOL_EN
HDP_INT#	VOL_VR

**INVENTEC**

TITLE **Chelsea 10MG KBC**

SIZE <b>A3</b>	CODE <b>CS</b>	DOC. NUMBER	REV <b>000</b>
		SHEET <b>44</b>	OF <b>70</b>

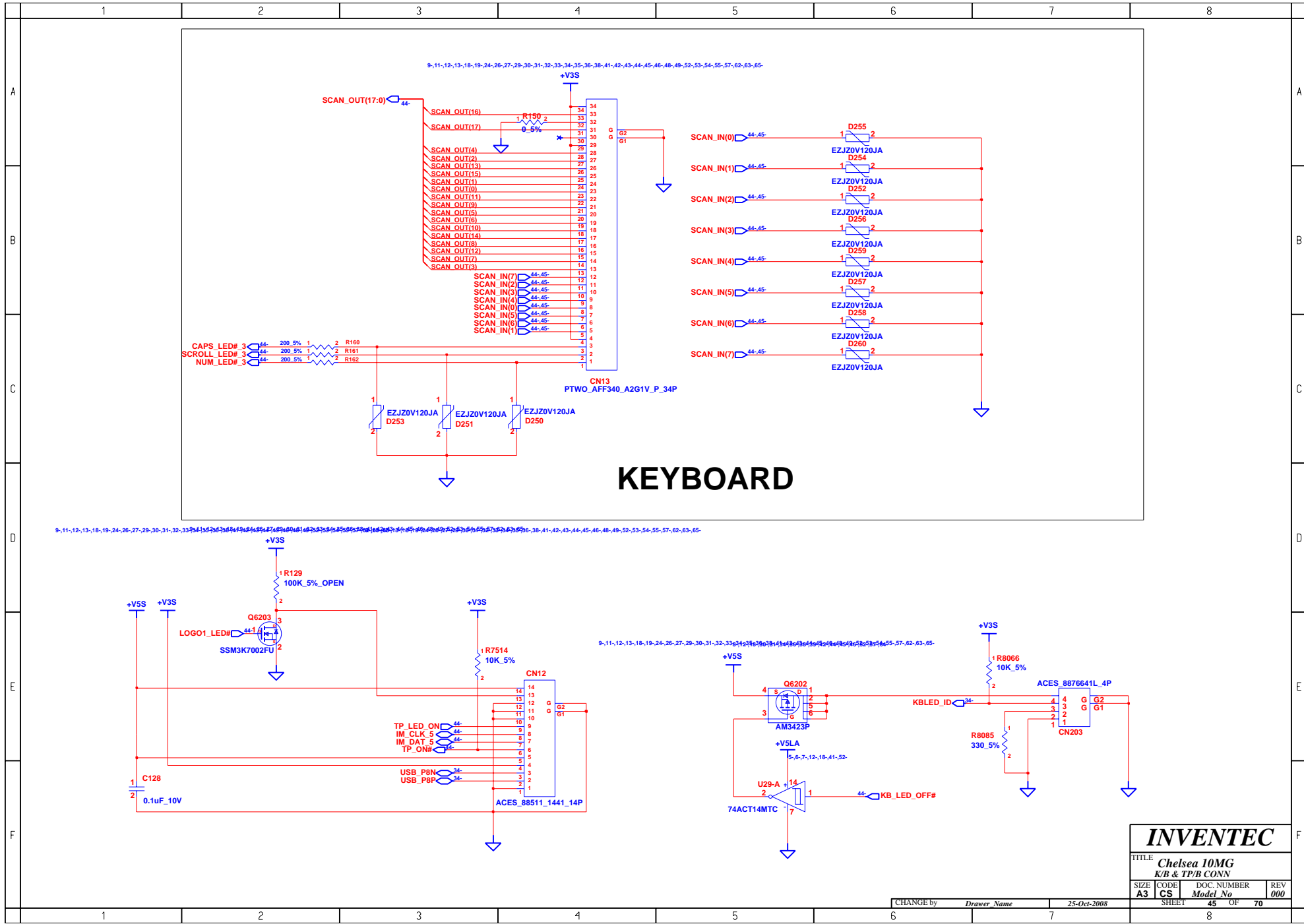

<b>INVENTEC</b>			
TITLE <i>Chelsea 10MG</i>			
K/B & TP/B CONN			
SIZE <b>A3</b>	CODE <b>CS</b>	DOC. NUMBER <i>Model No</i>	REV <b>000</b>
CHANGE by <i>Drawer Name</i>		25-Oct-2008	
SHEET <b>45</b>		OF <b>70</b>	

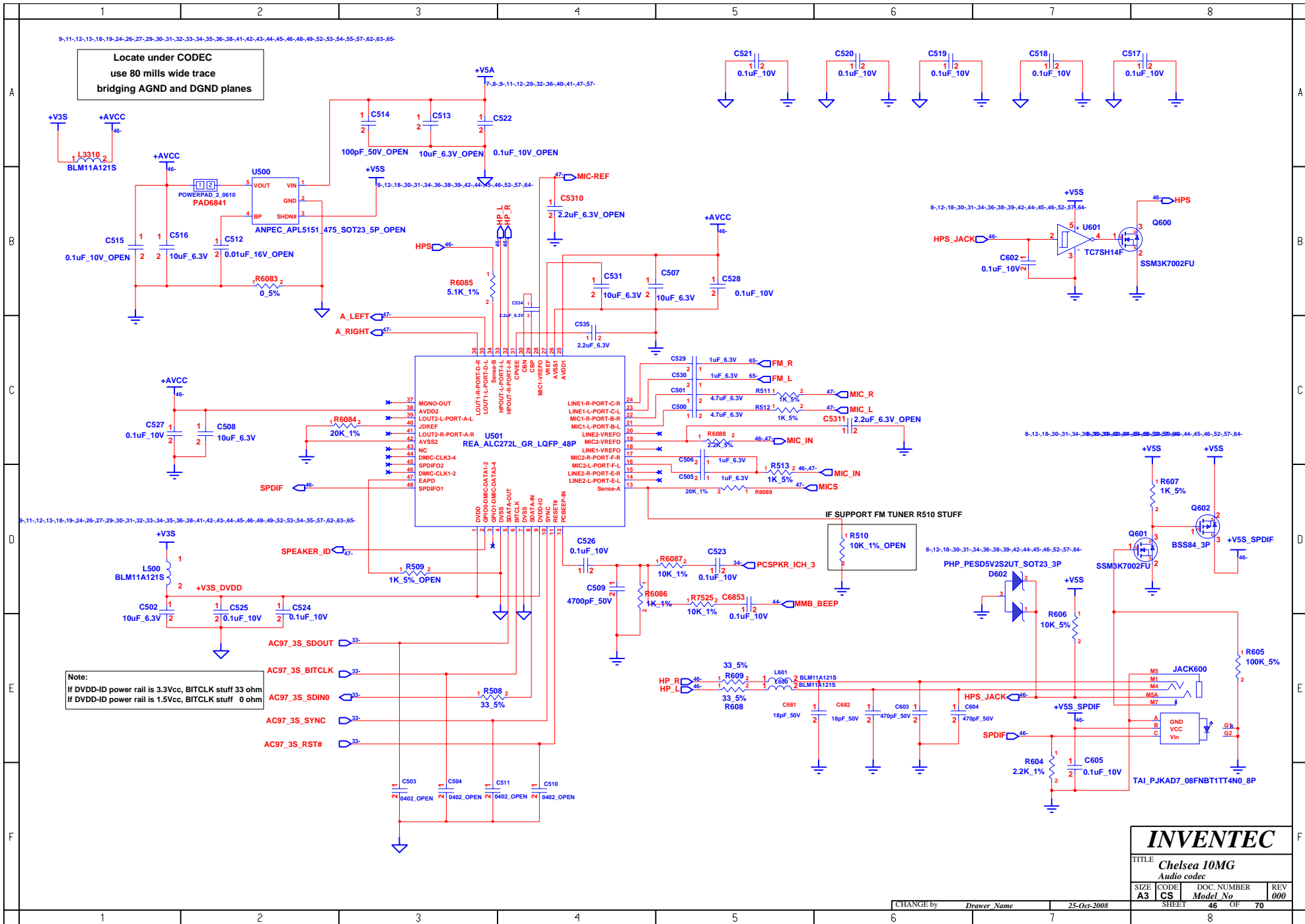

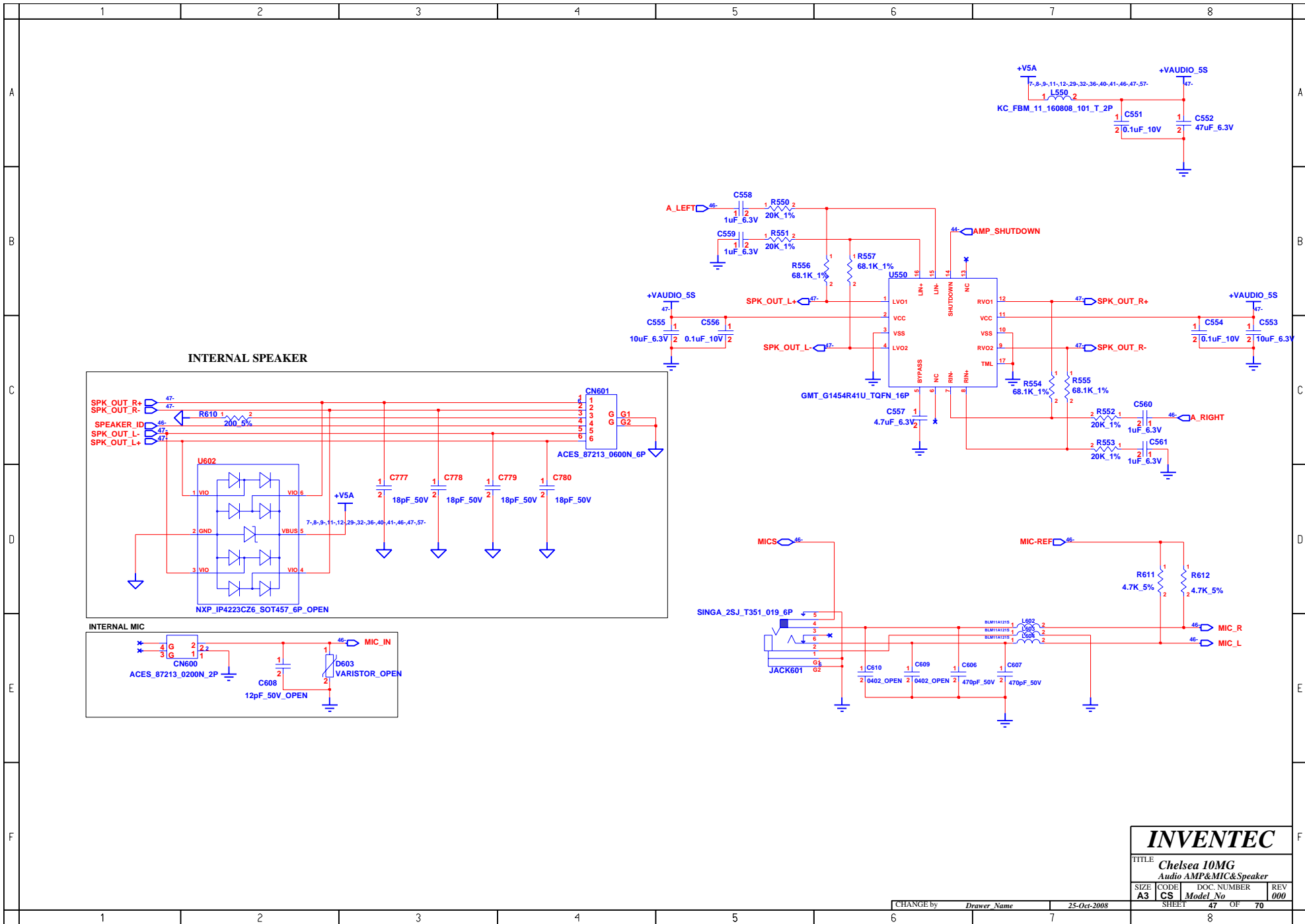

<b>INVENTEC</b>			
TITLE <i>Chelsea 10MG</i> Audio AMP&MIC&Speaker			
SIZE <b>A3</b>	CODE <b>CS</b>	DOC NUMBER Model No	REV <b>000</b>
CHANGE by <i>Drawer Name</i>		25-Oct-2008	
SHEET		47 OF 70	

# UWB

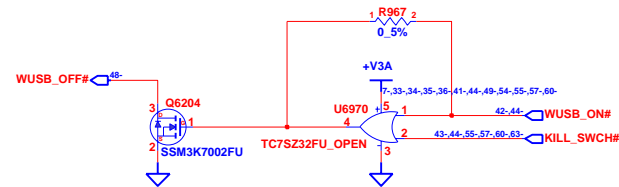
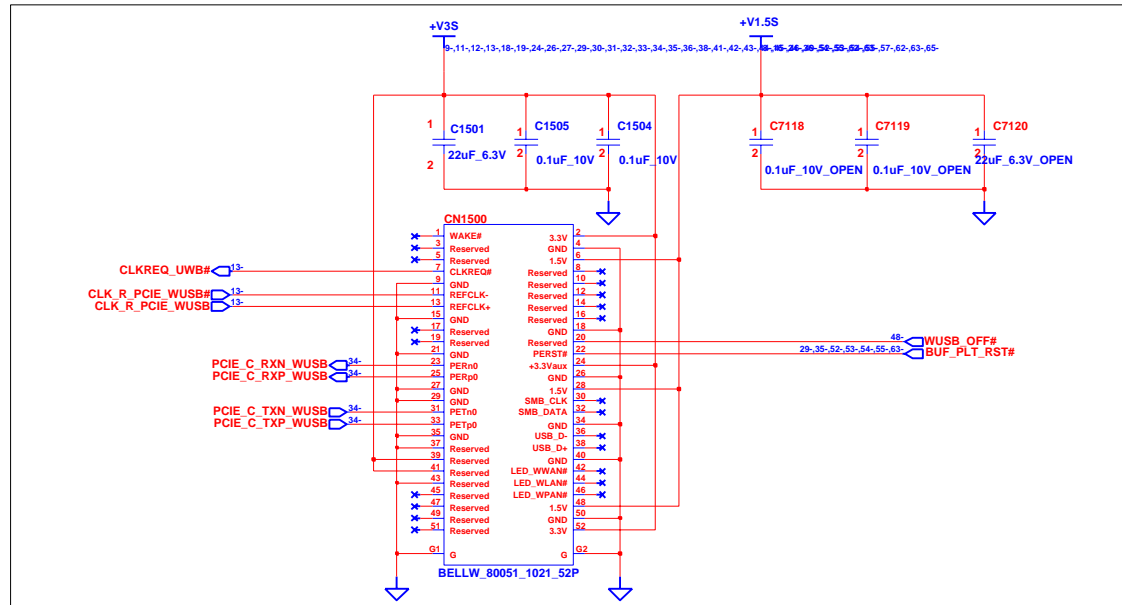

<b>INVENTEC</b>			
TITLE <i>Chelsea 10MG</i>			
WUSB			
SIZE <b>A3</b>	CODE <b>CS</b>	DOC. NUMBER <i>Model No</i>	REV <b>000</b>
CHANGE by <i>Drawer Name</i>		25-Oct-2008	
SHEET <b>48</b>		OF <b>70</b>	



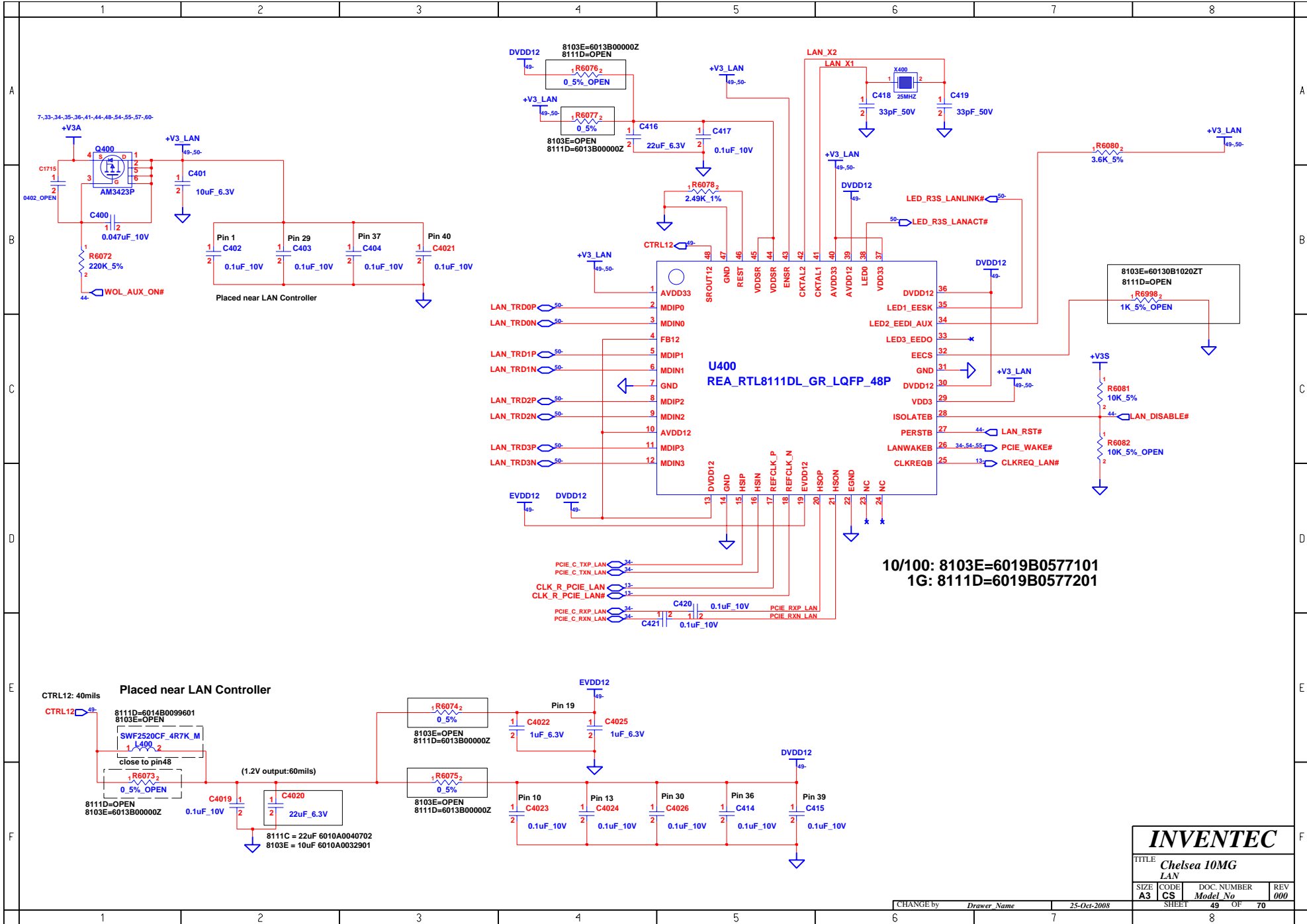

<b>INVENTEC</b>			
TITLE <b>Chelsea 10MG LAN</b>			
SIZE <b>A3</b>	CODE <b>CS</b>	DOC. NUMBER <b>Model No</b>	REV <b>000</b>
CHANGE by <i>Drawer Name</i>		25-Oct-2008	
SHEET <b>49</b>		OF <b>70</b>	

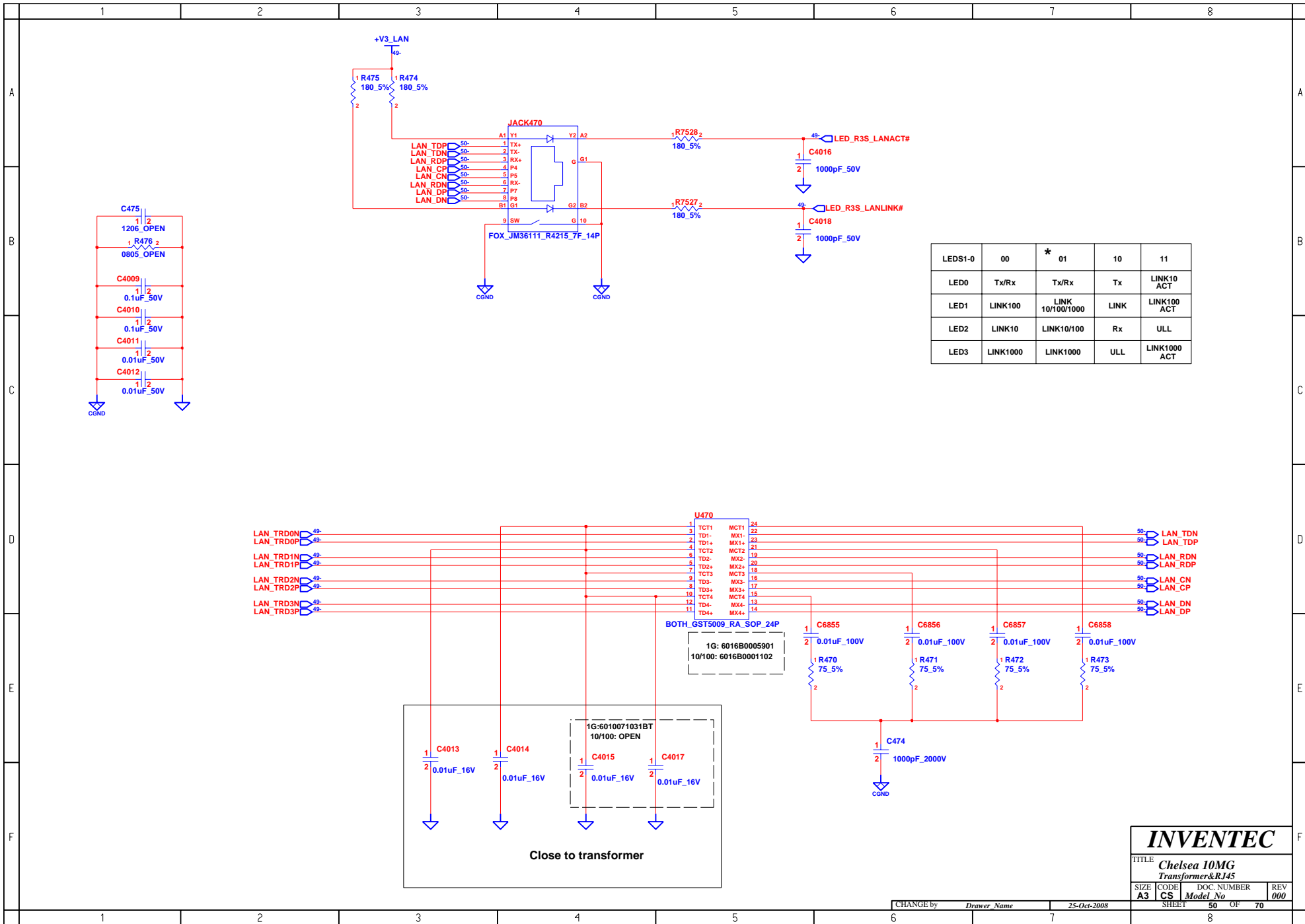

LEDS1-0	00	* 01	10	11
LED0	Tx/Rx	Tx/Rx	Tx	LINK10 ACT
LED1	LINK100	LINK 10/100/1000	LINK	LINK100 ACT
LED2	LINK10	LINK10/100	Rx	ULL
LED3	LINK1000	LINK1000	ULL	LINK1000 ACT

**INVENTEC**

TITLE			
Chelsea 10MG Transformer&RJ45			
SIZE	CODE	DOC. NUMBER	REV
A3	CS	Model No	000
SHEET		OF	TOTAL
50		OF	70

CHANGE by *Drawer Name* 25-Oct-2008

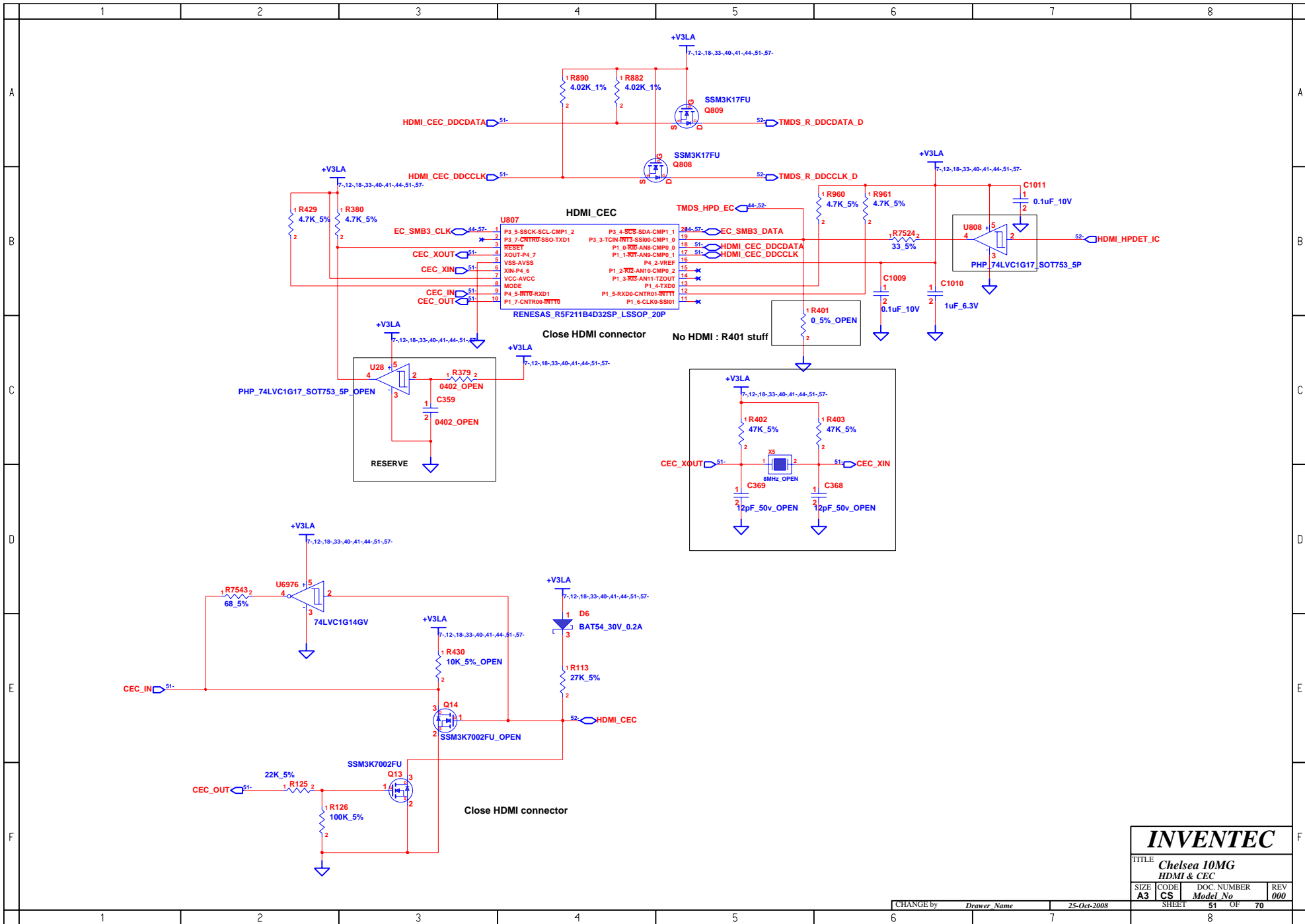

# INVENTEC

TITLE  
**Chelsea 10MG**  
**HDMI & CEC**

SIZE	CODE	DOC. NUMBER	REV
A3	CS	Model No	000

CHANGE by *Drawer Name* 25-Oct-2008

SHEET 51 OF 70

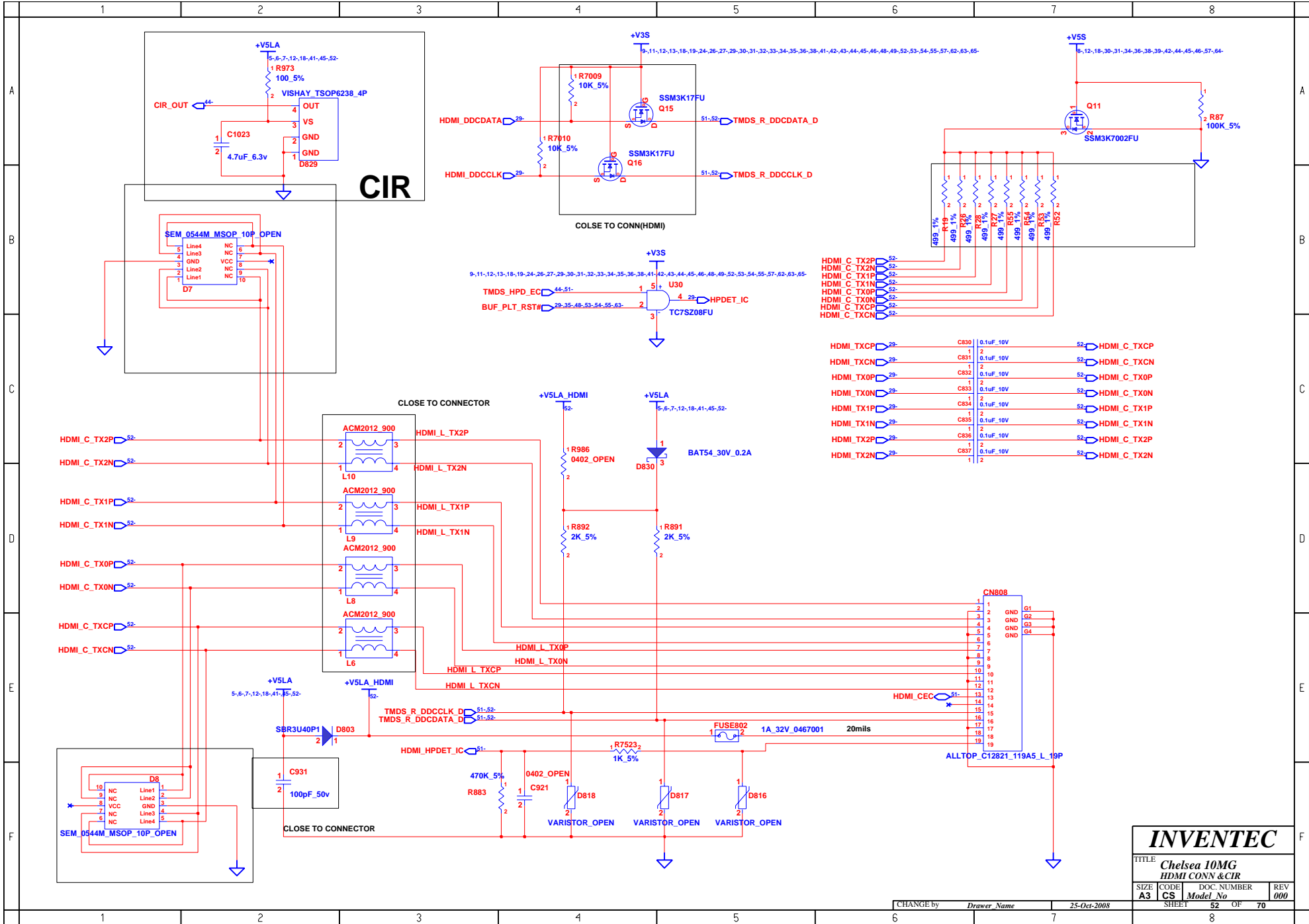

<b>INVENTEC</b>			
TITLE <b>Chelsea 10MG HDMI CONN &amp; CIR</b>			
SIZE <b>A3</b>	CODE <b>CS</b>	DOC NUMBER <i>Model No</i>	REV <b>000</b>
CHANGE by <i>Drawer Name</i>		25-Oct-2008	
SHEET <b>52</b>		OF <b>70</b>	

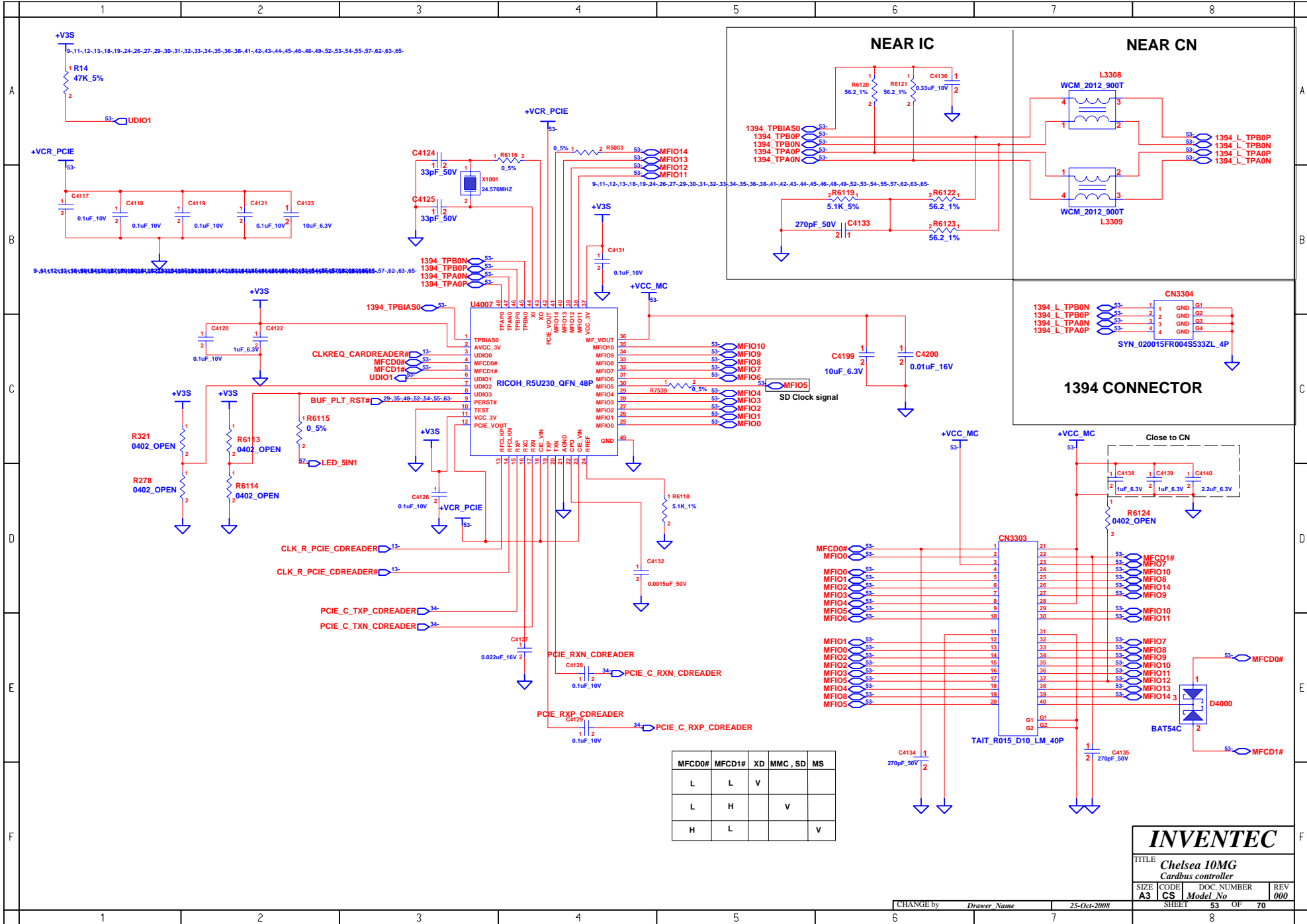

**INVENTEC**

TITLE: **Chelsea 10MG**  
**Cardbus controller**

SIZE: **A3** CODE: **CS** DOC NUMBER: **Model No** REV: **000**

CHANGE by: *Drawer Name* 25-Oct-2008 SHEET: **53** OF **70**

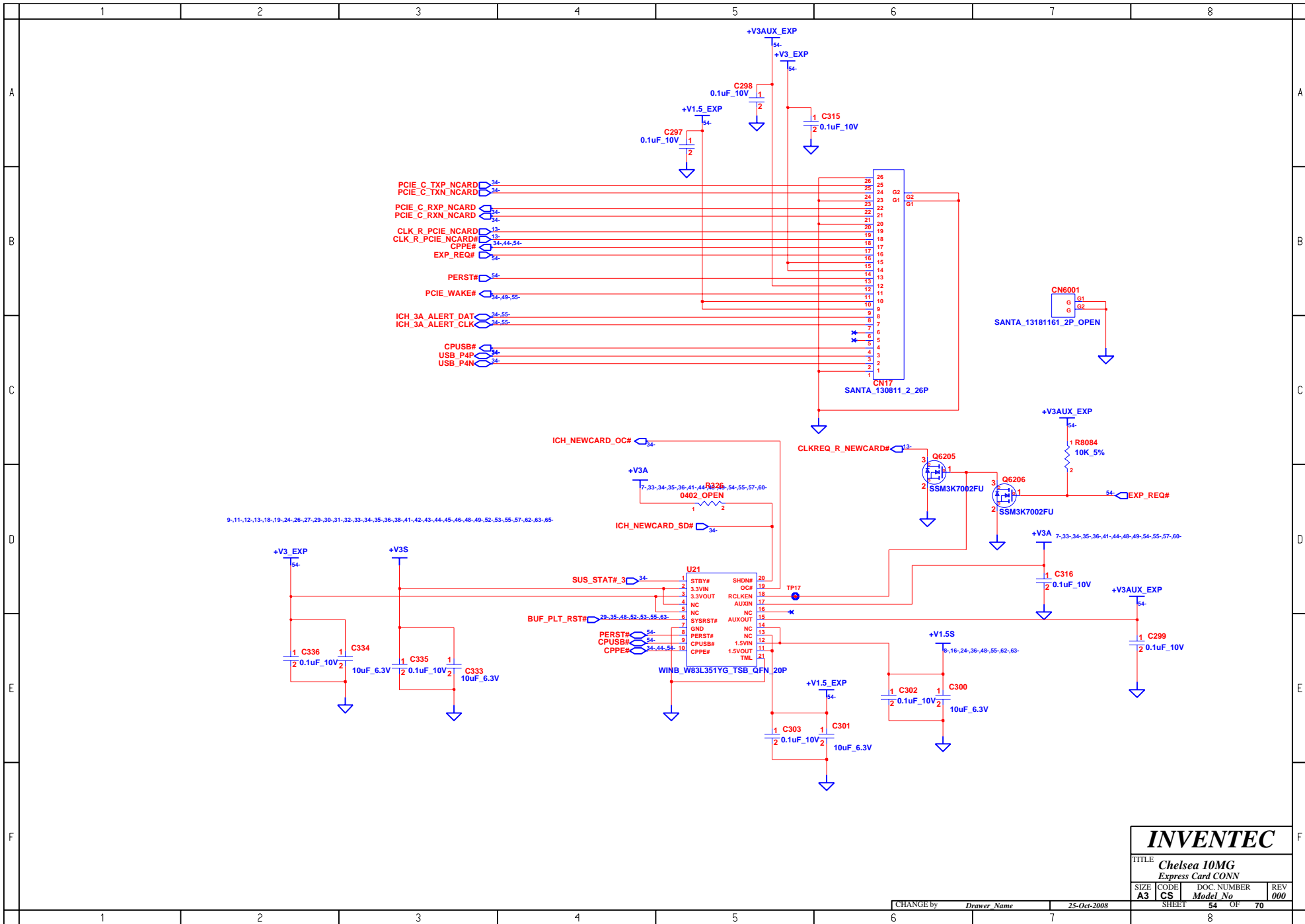

<b>INVENTEC</b>			
TITLE <i>Chelsea 10MG Express Card CONN</i>			
SIZE <b>A3</b>	CODE <b>CS</b>	DOC. NUMBER <i>Model No</i>	REV <b>000</b>
CHANGE by <i>Drawer Name</i>		25-Oct-2008	
SHEET <b>54</b>		OF <b>70</b>	



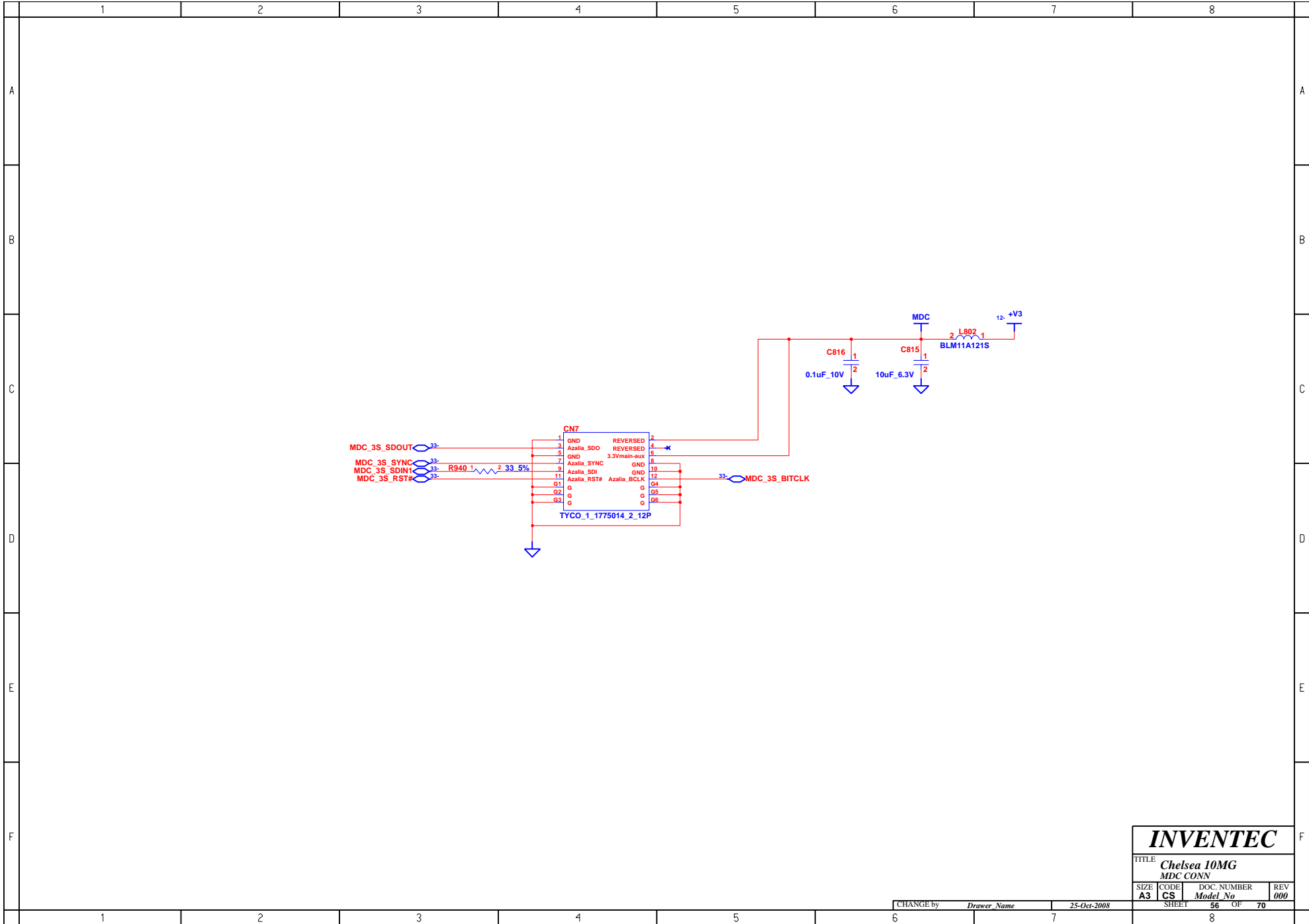

**INVENTEC**

TITLE *Chelsea 10MG*  
MDC CONN

SIZE	CODE	DOC. NUMBER	REV
A3	CS	Model No	000

CHANGE by	Drawer Name	25-Oct-2008	SHEET	56	OF	70
1	2	3	4	5	6	7



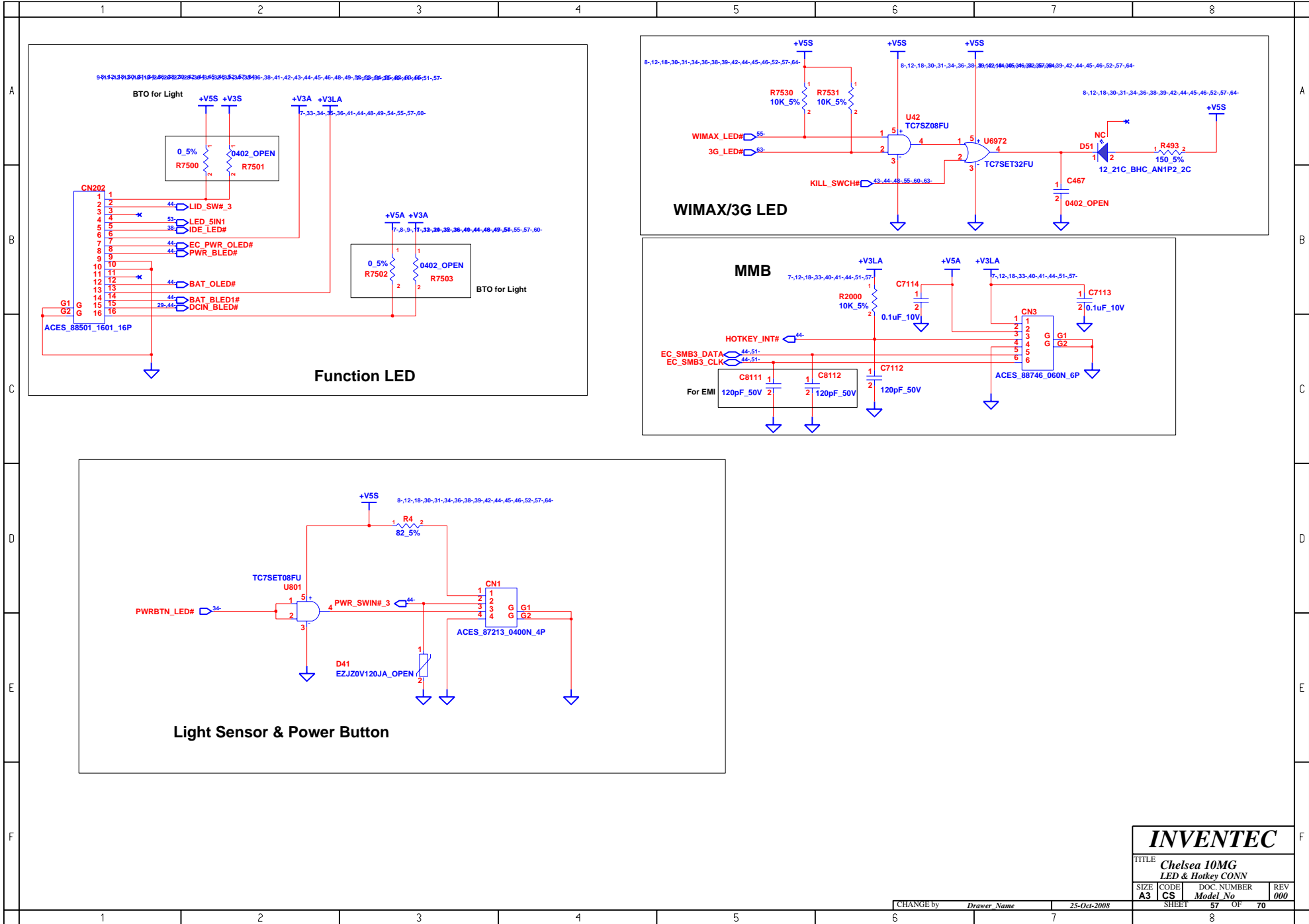

**INVENTEC**

TITLE  
**Chelsea 10MG  
 LED & Hotkey CONN**

SIZE <b>A3</b>	CODE <b>CS</b>	DOC. NUMBER <i>Model No</i>	REV <b>000</b>
-------------------	-------------------	--------------------------------	-------------------

CHANGE by *Drawer Name* 25-Oct-2008 SHEET 57 OF 70

**BLANK**

<b>INVENTEC</b>			
TITLE <i>Chelsea 10MG FingerPrint Board</i>			
SIZE <b>A3</b>	CODE <b>CS</b>	DOC. NUMBER <i>Model No</i>	REV <b>000</b>
CHANGE by <i>Drawer Name</i>		25-Dec-2008	
SHEET		58	OF 70

	1	2	3	4	5	6	7	8	
A									A
B									B
C									C
D									D
E									E
F									F
	1	2	3	4	5	6	7	8	

**BLANK**

<b>INVENTEC</b>			
TITLE <i>Chelsea 10MG FM Board</i>			
SIZE <b>A3</b>	CODE <b>CS</b>	DOC. NUMBER <i>Model No</i>	REV <b>000</b>
CHANGE by <i>Drawer Name</i>		25-Dec-2008	
SHEET		59	OF 70
		8	

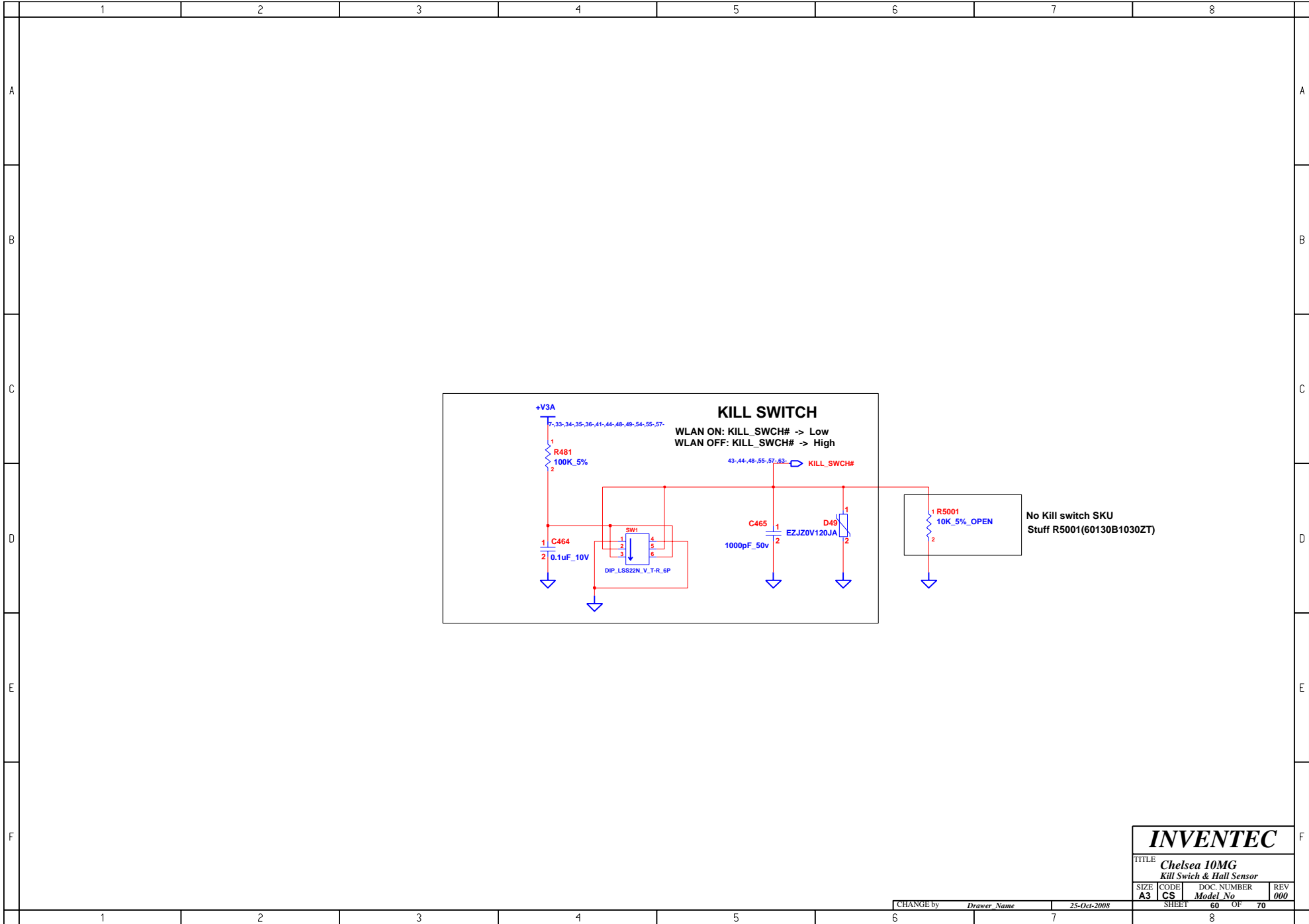

**INVENTEC**

TITLE **Chelsea 10MG**  
**Kill Swich & Hall Sensor**

SIZE	CODE	DOC. NUMBER	REV
A3	CS	Model No	000

CHANGE by *Drawer Name* 25-Oct-2008

SHEET 60 OF 70

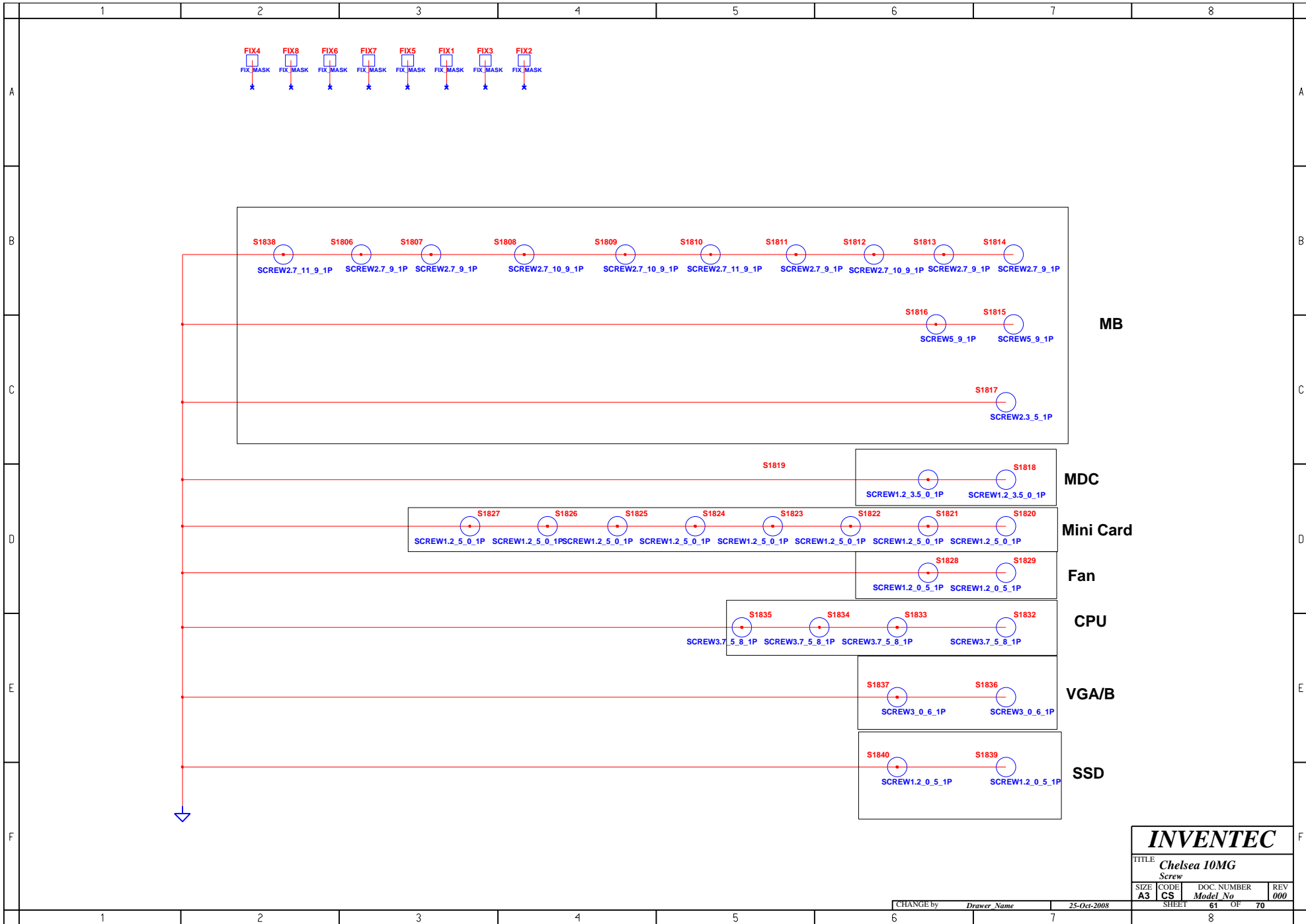

<b>INVENTEC</b>			
TITLE <i>Chelsea 10MG</i>			
Screw			
SIZE	CODE	DOC. NUMBER	REV
A3	CS	Model No	000
CHANGE by <i>Drawer Name</i>		25-Oct-2008	
SHEET 61		OF 70	

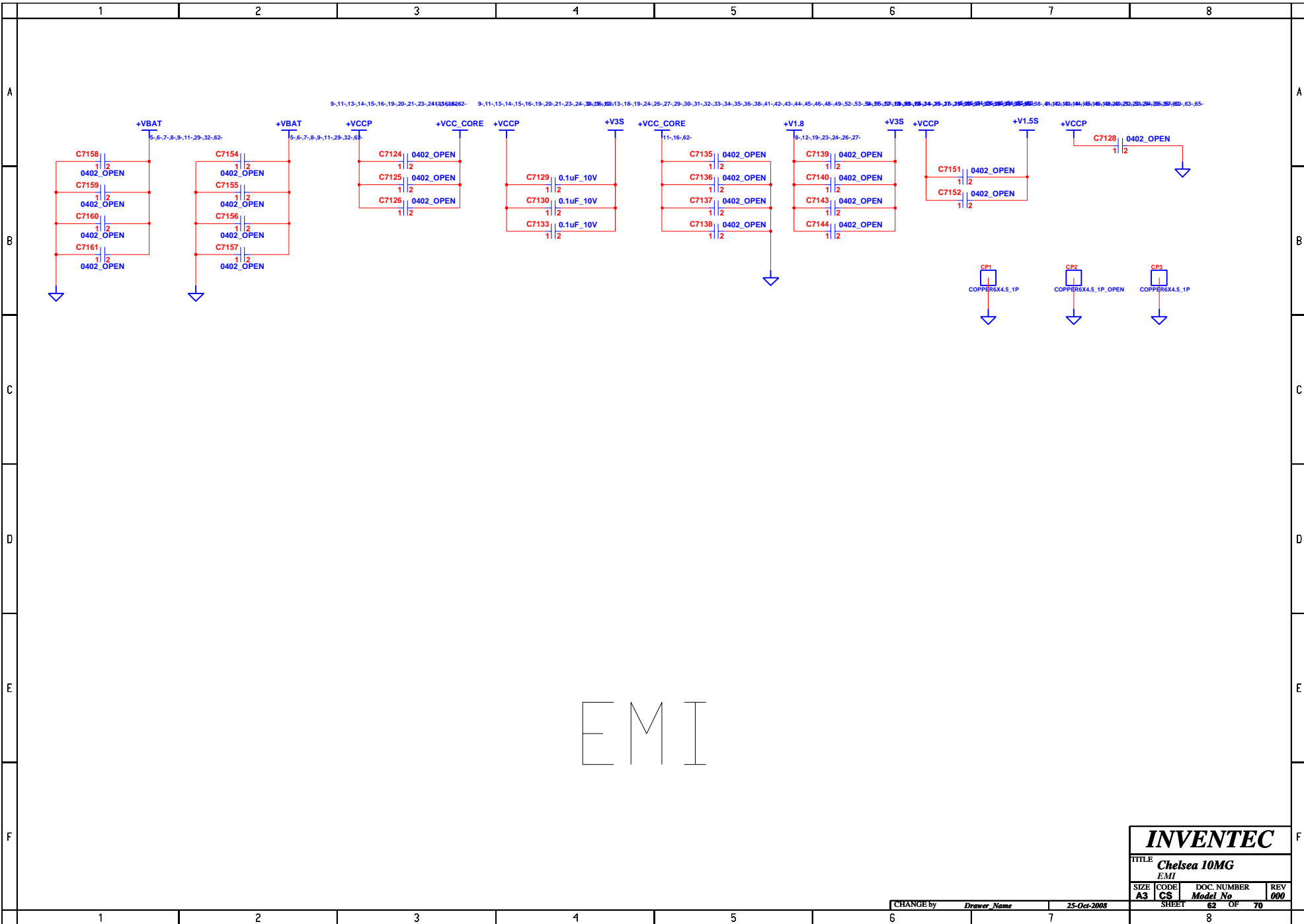

**INVENTEC**

TITLE **Chelsea 10MG**  
EMI

SIZE <b>A3</b>	CODE <b>CS</b>	DOC. NUMBER <b>Model No</b>	REV <b>000</b>
CHANGE by <i>Drawer Name</i>		25-Oct-2008	
SHEET		62 OF	70

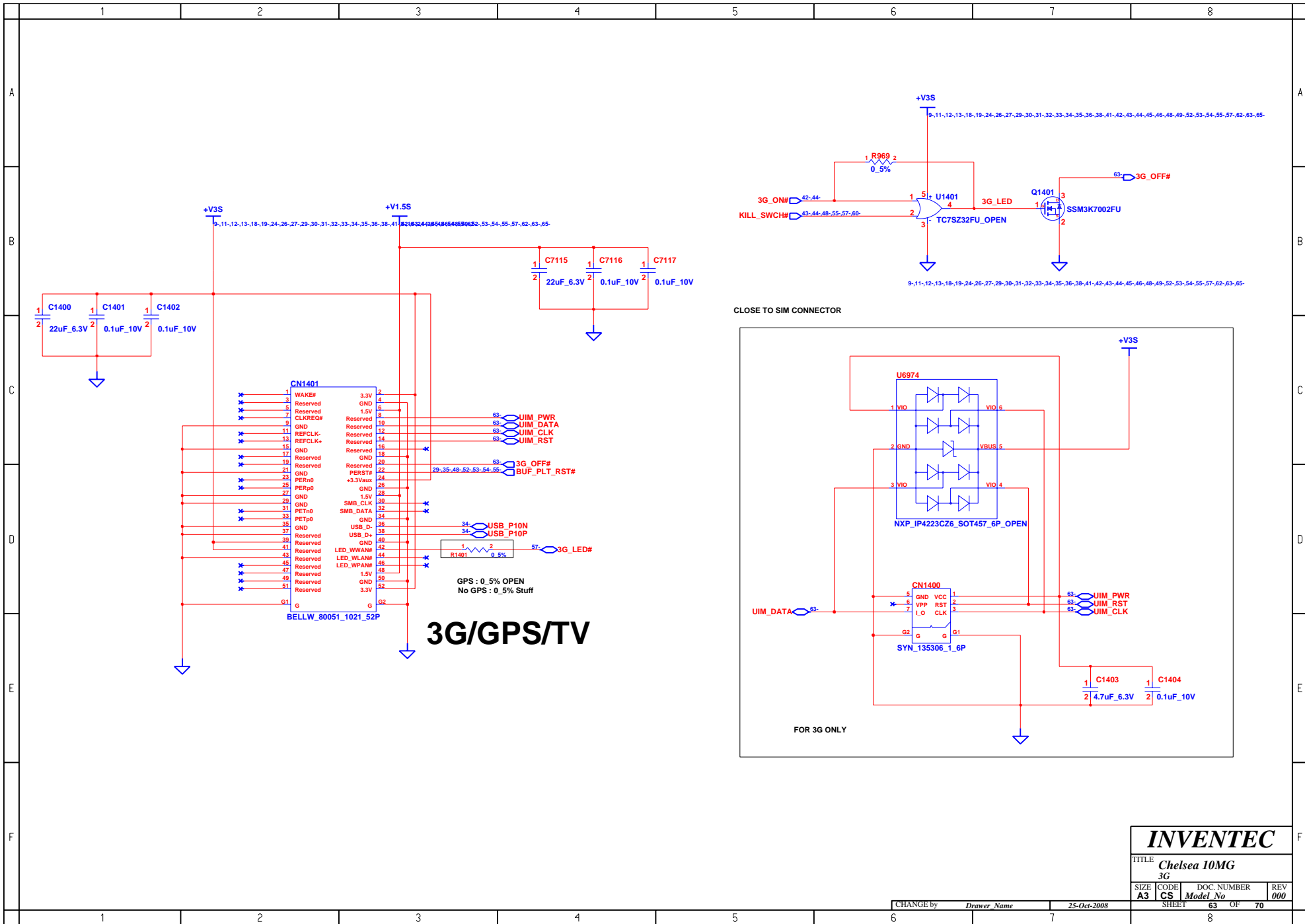

<b>INVENTEC</b>			
TITLE <i>Chelsea 10MG</i>			
SIZE <i>3G</i>			
SIZE <b>A3</b>	CODE <b>CS</b>	DOC. NUMBER <i>Model No</i>	REV <i>000</i>
CHANGE by <i>Drawer Name</i>		25-Oct-2008	
SHEET <b>63</b>		OF <b>70</b>	

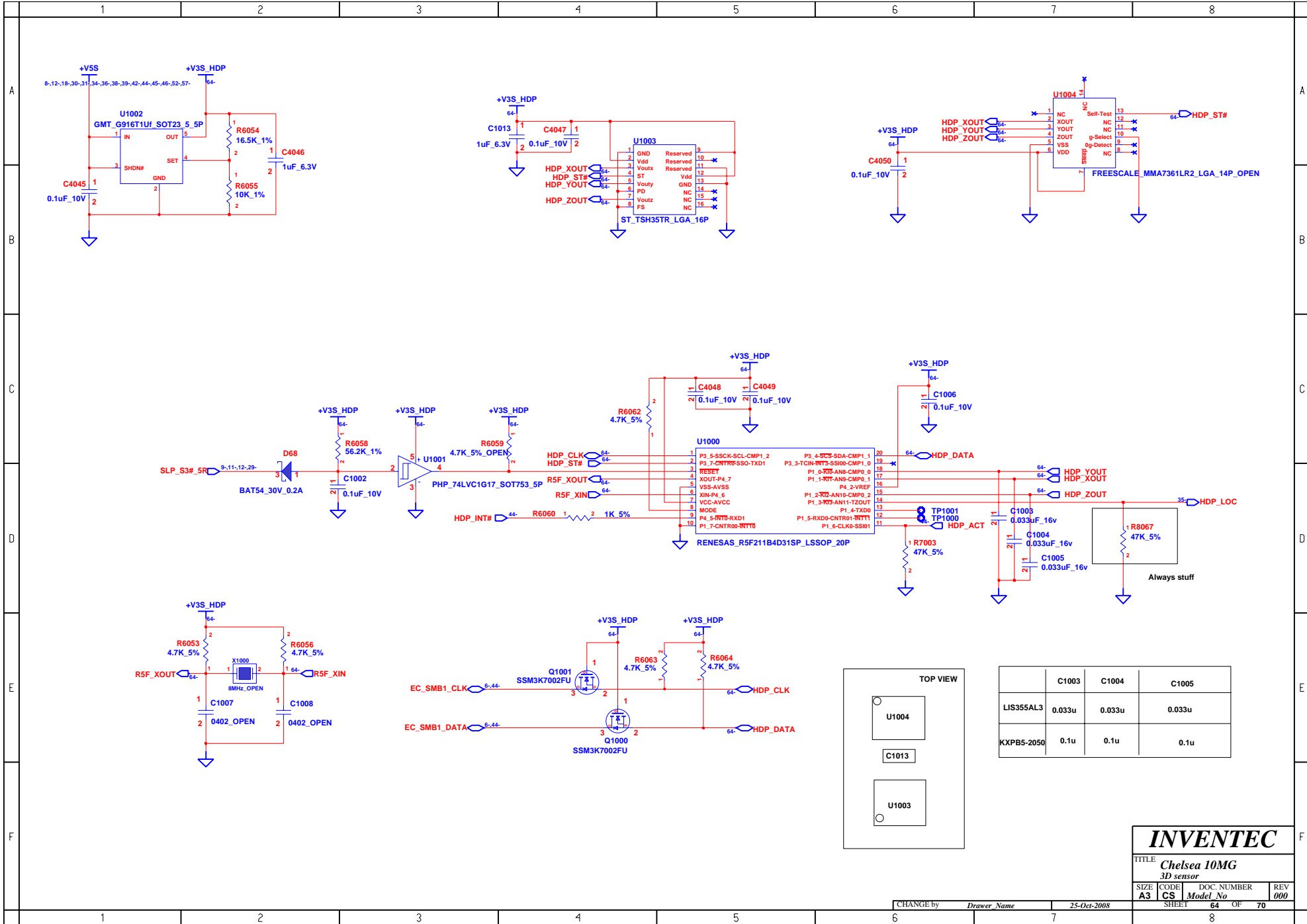

**INVENTEC**

TITLE  
 Chelsea 10MG  
 3D sensor

SIZE CODE DOC. NUMBER REV  
 A3 CS Model No 64 OF 70

CHANGE by Drawer Name 25-Oct-2008



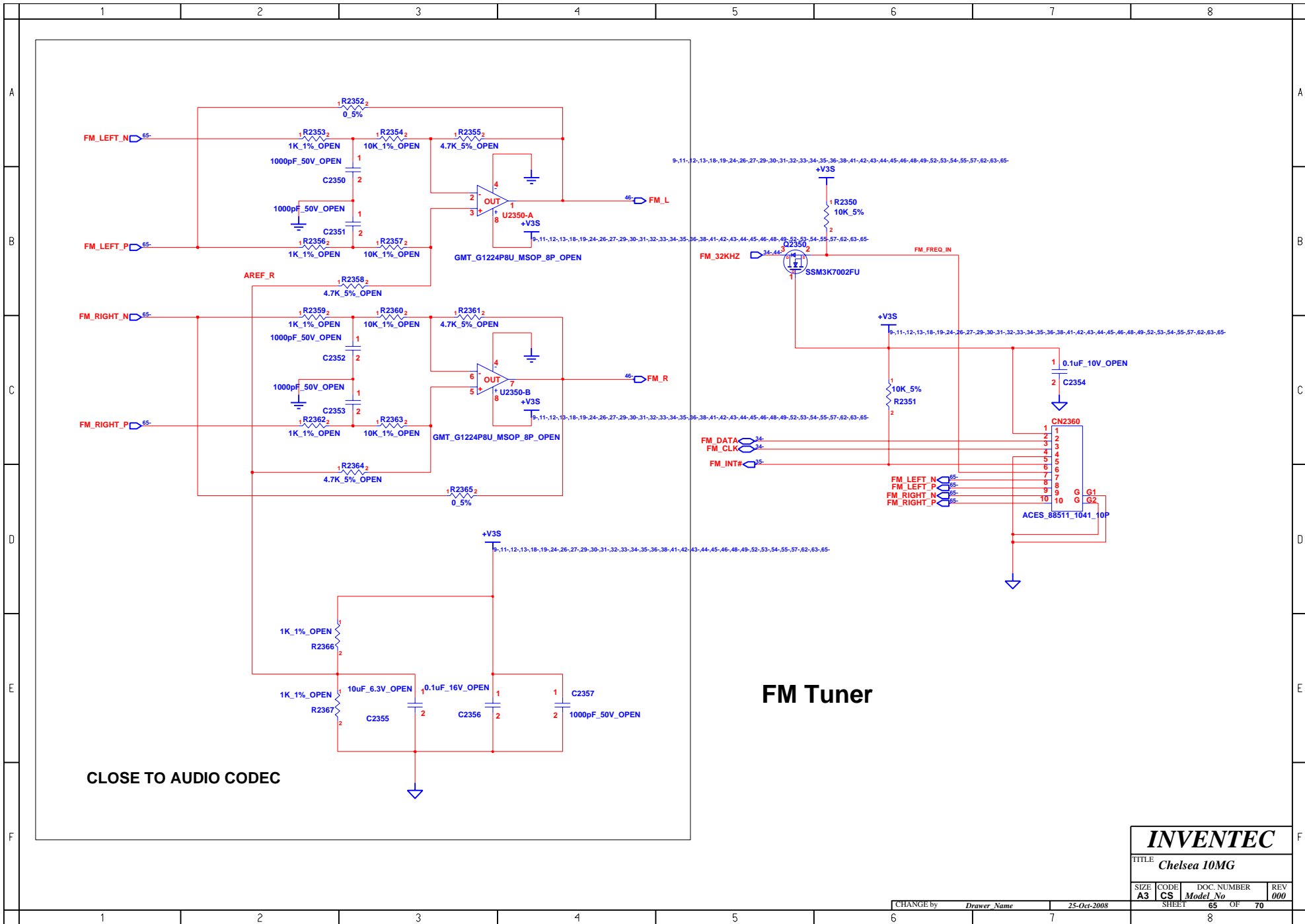

<b>INVENTEC</b>			
TITLE <i>Chelsea 10MG</i>			
SIZE <b>A3</b>	CODE <b>CS</b>	DOC. NUMBER <i>Model No</i>	REV <b>000</b>
CHANGE by <i>Drawer Name</i>		25-Oct-2008	SHEET <b>65</b> OF <b>70</b>

# PICK BUTTON BOARD

(For - Touchpad Module, Touchpad Switch Board, Fingerprint Module)

Connect to Touchpad Module

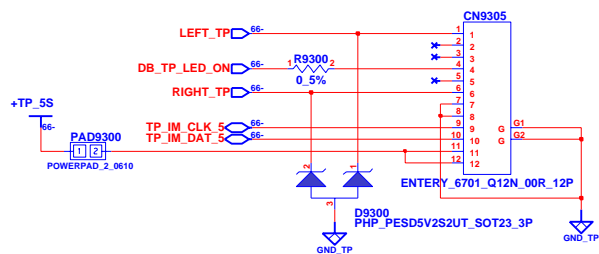

Connect to Mainboard's TP connector

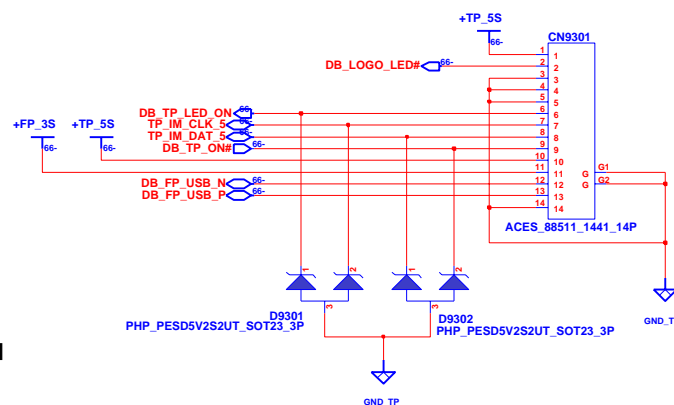

Connect to LOGO LED Board

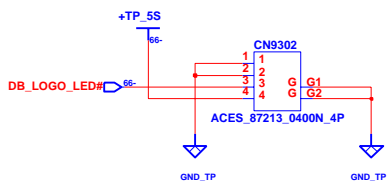

Connect to Touchpad Switch Board

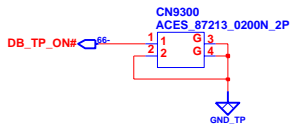

Connect to Fingerprint Module

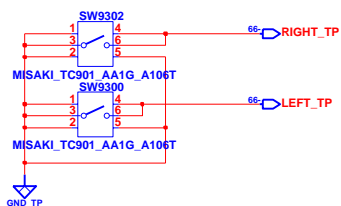
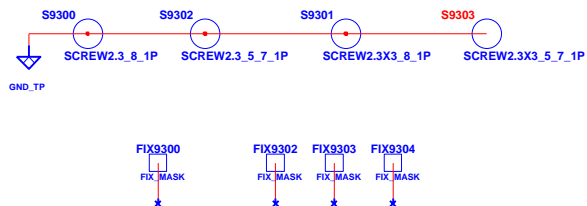
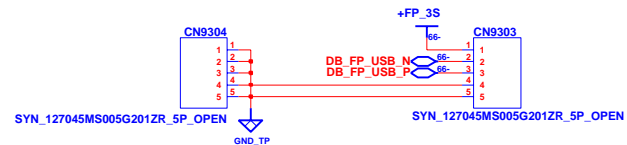

**INVENTEC**

TITLE *Chelsea 10MG*

SIZE <b>A3</b>	CODE <b>CS</b>	DOC. NUMBER <i>Model No</i>	REV <b>000</b>
-------------------	-------------------	--------------------------------	-------------------

CHANGE by *Drawer Name* 6-Apr-2009

SHEET **66** OF **70**

# TOUCHPAD SWITCH BOARD

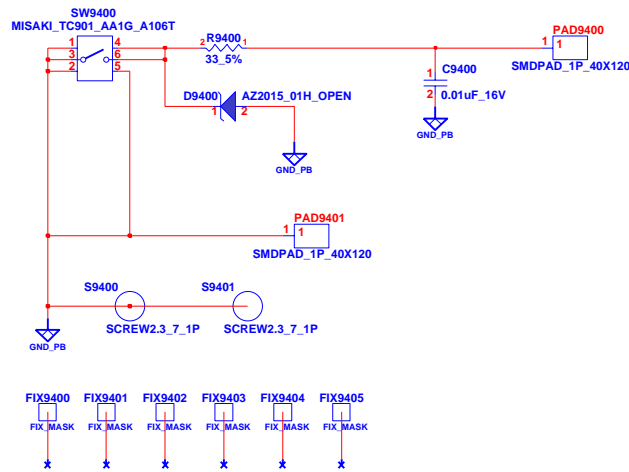

<b>INVENTEC</b>			
TITLE CS10MG-6050A2251001-MB-AXI-26			
SIZE A3	CODE CS	DOC. NUMBER	REV
SHEET		67 OF	70

CHANGE by CS10MG 16-Feb-2009

# LED & HALL SENSOR BOARD

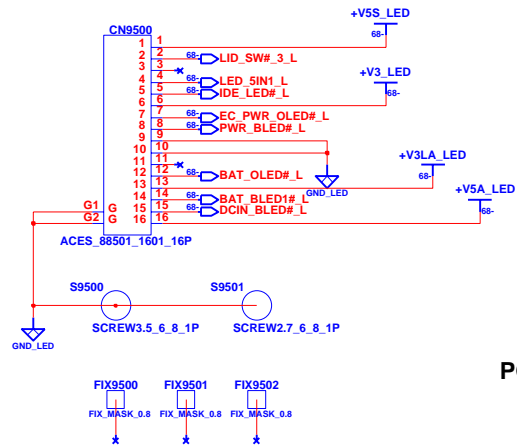

5IN1 LED

HDD LED

POWER LED

BATTERY LED

DC LED

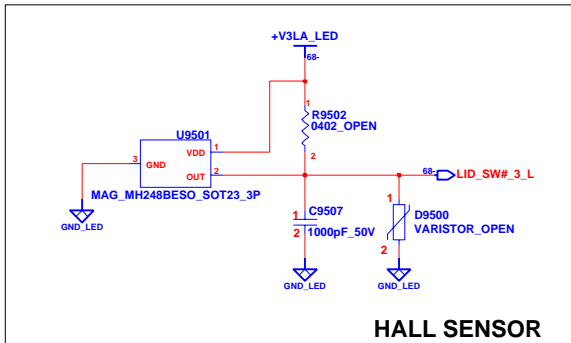
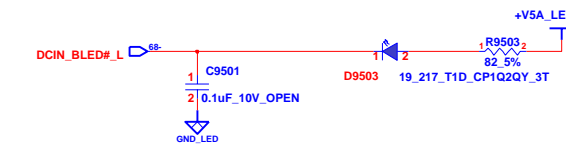
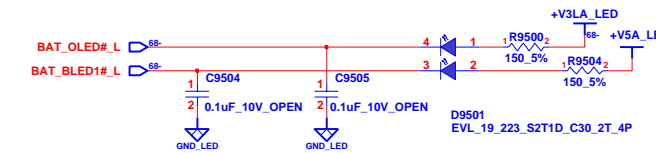
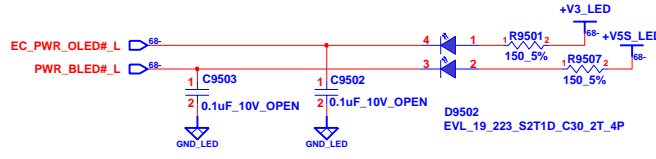
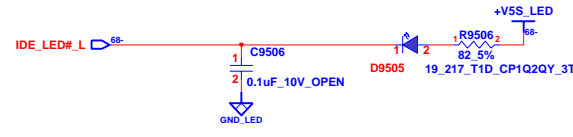
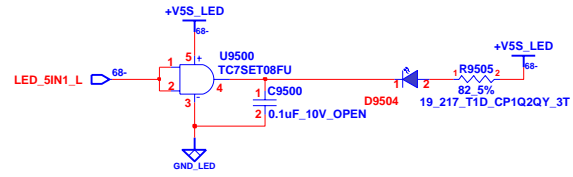

HALL SENSOR

<b>INVENTEC</b>			
TITLE CS10MG-6050A2251001-MB-AX1-26			
SIZE	CODE	DOC. NUMBER	REV
A3	CS	SHEET 68 OF 70	

CHANGE by CS10MG 22-Dec-2008

# LOGO LED BOARD

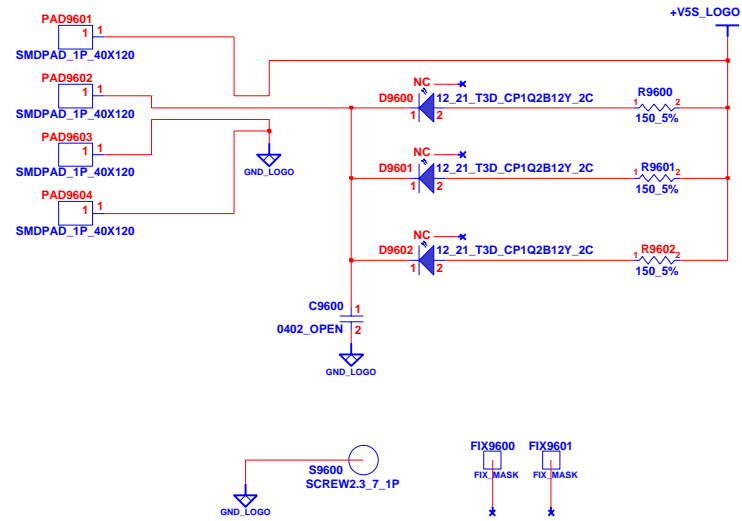

<b>INVENTEC</b>			
TITLE CS10MG-6050A2251001-MB-AX1-26			
SIZE A3	CODE CS	DOC. NUMBER 69 OF 70	REV SHEET
CHANGE by CS10MG		16-Feb-2009	
1	2	3	8

# POWER BUTTON & LIGHT SENSOR BOARD

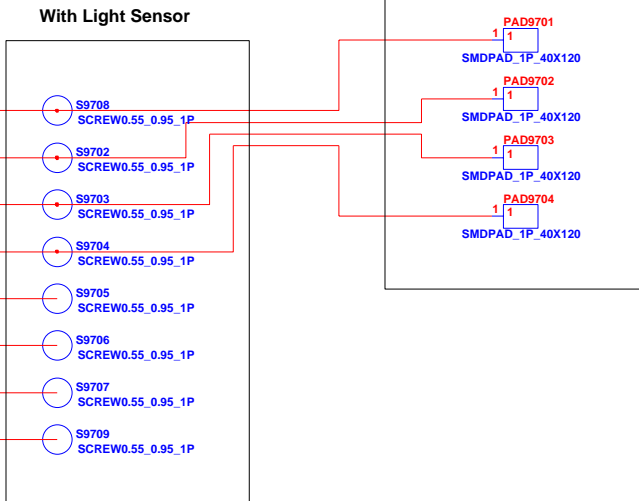
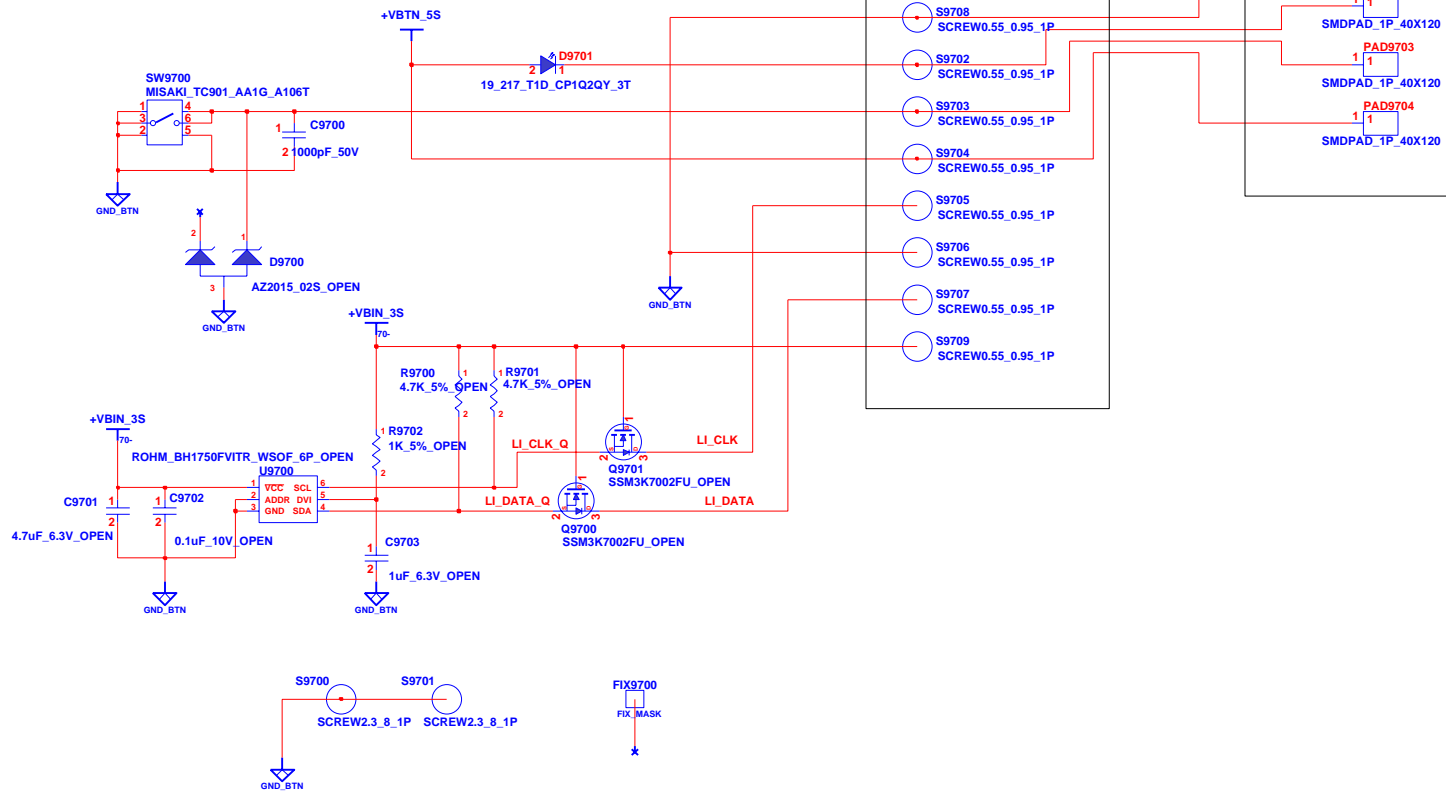

<b>INVENTEC</b>			
TITLE CS10MG-6050A2251001-MB-AX1-26			
SIZE A3	CODE CS	DOC. NUMBER 70 OF 70	REV SHEET

CHANGE by CS10MG 30-Mar-2009