

MANAUS 10AD

A02 Build

2010.03.17

INVENTEC

TITLE
Manaus10AD

SIZE	CODE	DOC. NUMBER	REV
A3	CS	1310A2357401	X01

CHANGE by *Eddy, Chen* 17-Mar-2010

SHEET 1 OF 43

TABLE OF CONTENTS

PAGE

- 1. COVER PAGE
- 2. INDEX
- 3. BLOCK DIAGRAM
- 4. POWER SEQUENCE BLOCK
- 5. PCB
- 6. SYSTEM POWER
- 7. SYSTEM POWER
- 8. SYSTEM POWER
- 9. SYSTEM POWER
- 10. SYSTEM POWER
- 11. SYSTEM POWER
- 12. SYSTEM POWER
- 13. SUPER I/O(KBC)
- 14. K/B & TP/B CONN
- 15. FAN & THERMAL
- 16. LAN
- 17. RJ45 & TRANSFORMER
- 18. AUDIO CODEC
- 19. SPDIF & MIC & HP
- 20. CARD READER
- 21. LCM
- 22. RGB CONN
- 23. SATA HDD & ODD
- 24. USB
- 25. WLAN
- 26. LID SW
- 27. LED
- 28. DDR2 DIMM0
- 29. DDR2 DIMM1
- 30. CPU 1

PAGE

- 31. CPU 2
- 32. CPU 3
- 33. CPU 4
- 34. N/B 1
- 35. N/B 2
- 36. N/B 3
- 37. N/B 4
- 38. S/B 1
- 39. S/B 2
- 40. S/B 3
- 41. S/B 4
- 42. EMI
- 43. POWER BOARD (DB)

INVENTEC			
<small>TITLE</small> Manaus10AD Index			
<small>SIZE</small> A3	<small>CODE</small> CS	<small>DOC. NUMBER</small> 1310A2357401	<small>REV</small> X01
<small>CHANGE by</small> <i>Eddy, Chen</i>		<small>25-Jan-2010</small>	
<small>SHEET</small> 2		<small>OF</small> 43	

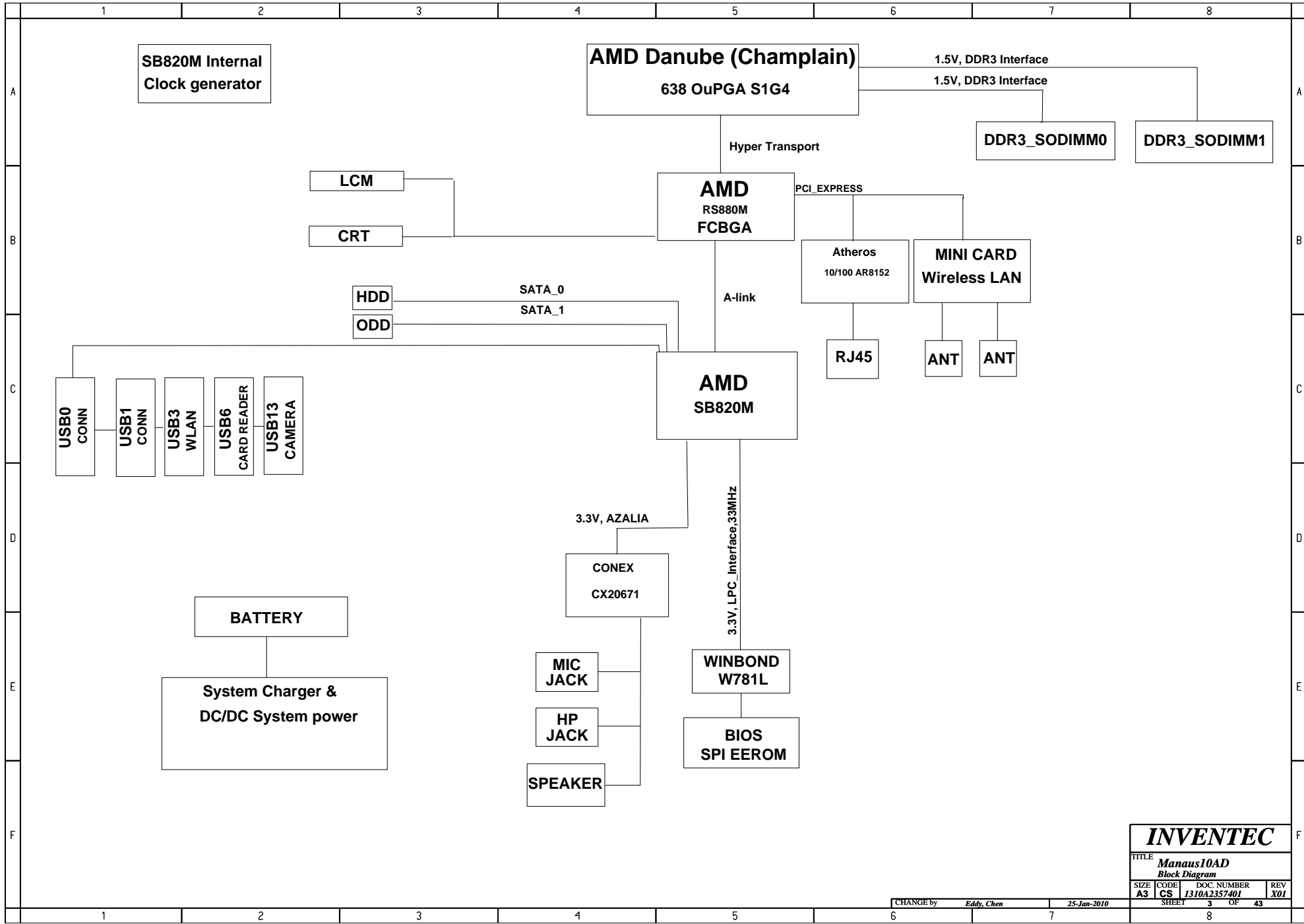

INVENTEC			
TITLE Manus10AD			
Block Diagram			
SIZE A3	CODE CS	DOC. NUMBER 1310A2357401	REV X01
CHANGE by <i>Eddy, Chen</i>		25-Jan-2010	
SHEET 3		OF 43	

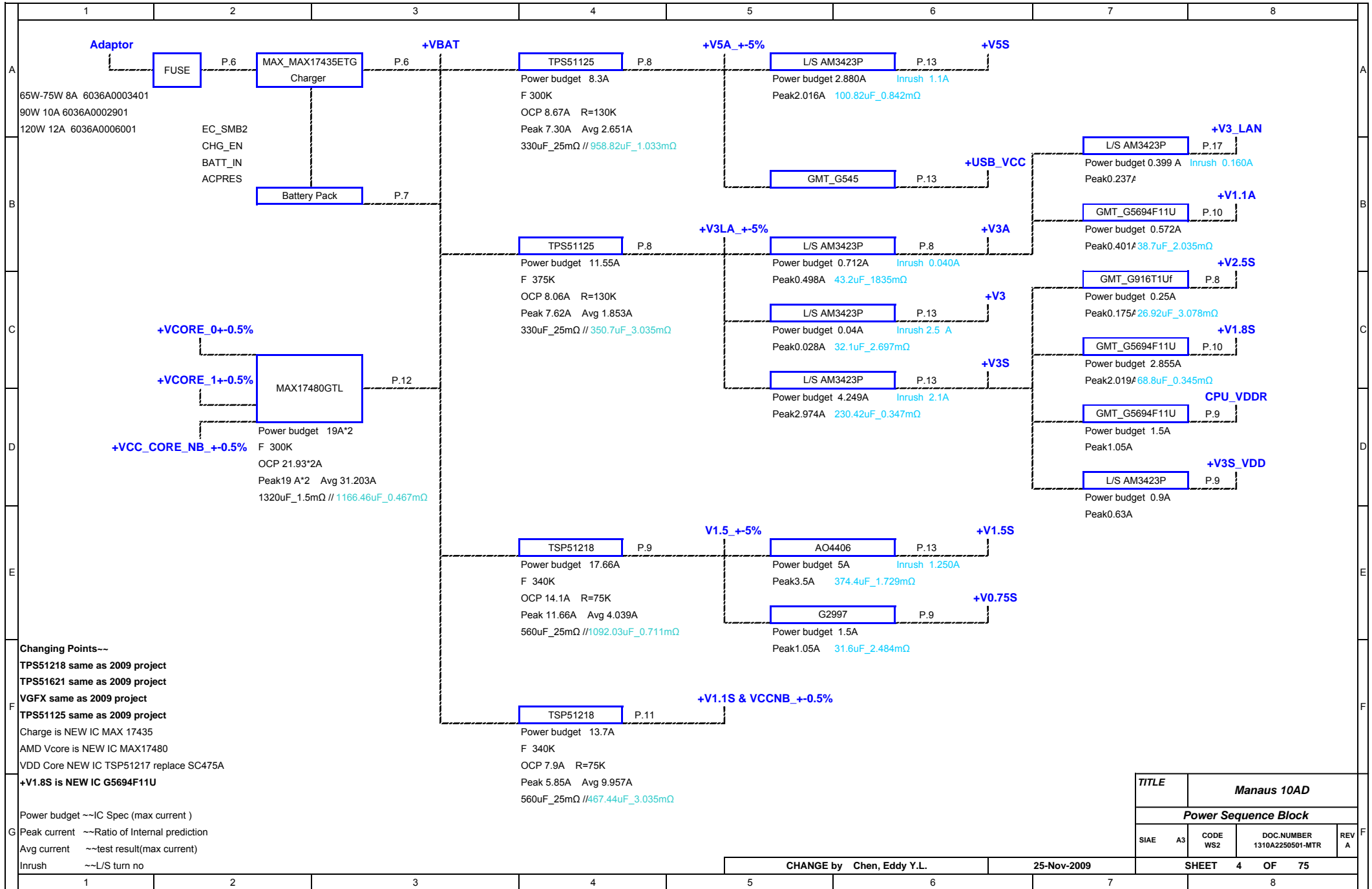

TITLE		Manaus 10AD			
Power Sequence Block					
SIAE	A3	CODE WS2	DOC.NUMBER	REV	A
			1310A2250501-MTR		
CHANGE by Chen, Eddy Y.L.			25-Nov-2009		SHEET 4 OF 75

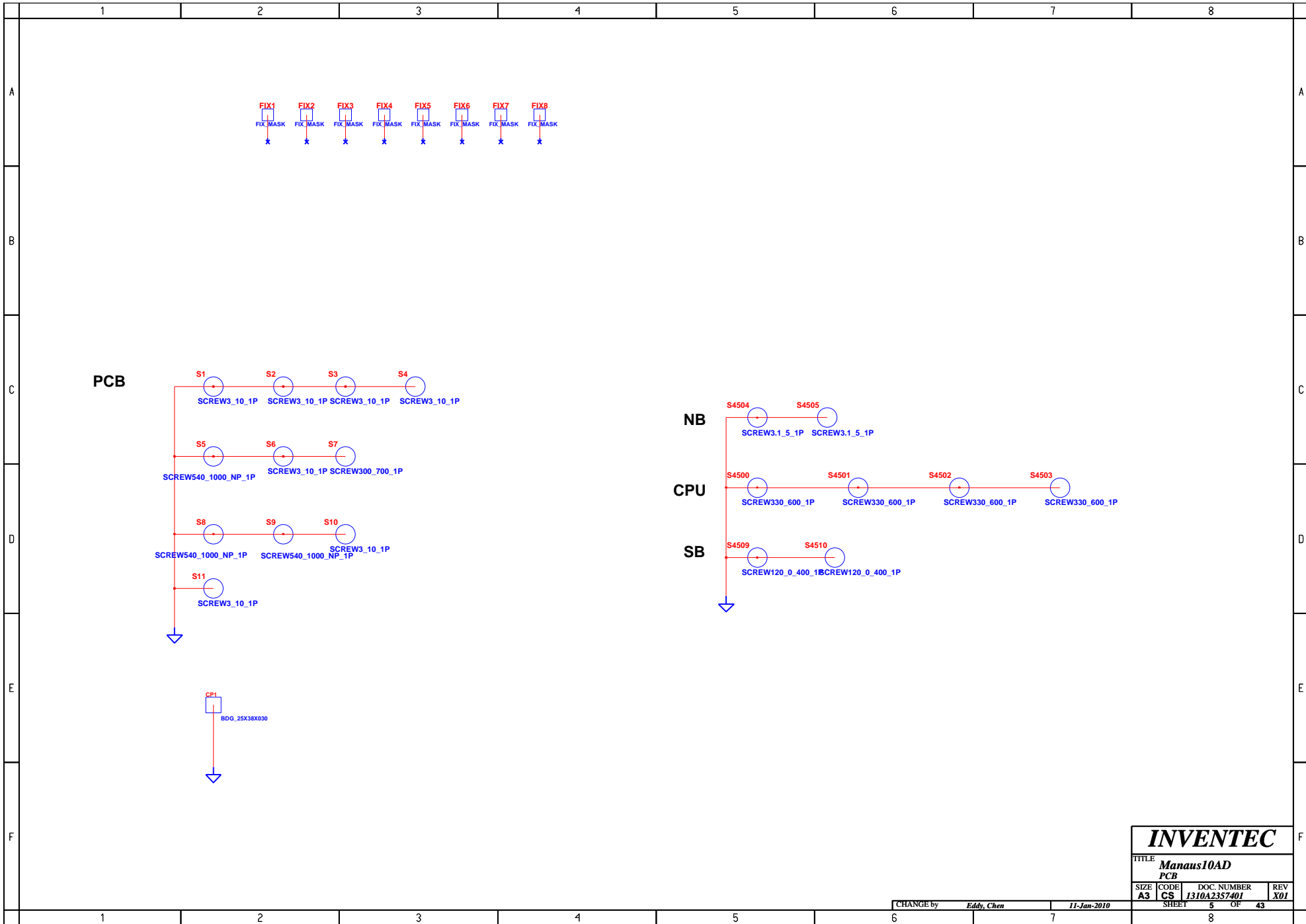

INVENTEC

TITLE **Manaus10AD**
PCB

SIZE	CODE	DOC. NUMBER	REV
A3	CS	1310A2357401	X01

CHANGE by *Eddy, Chen* 11-Jan-2010

SHEET 5 OF 43

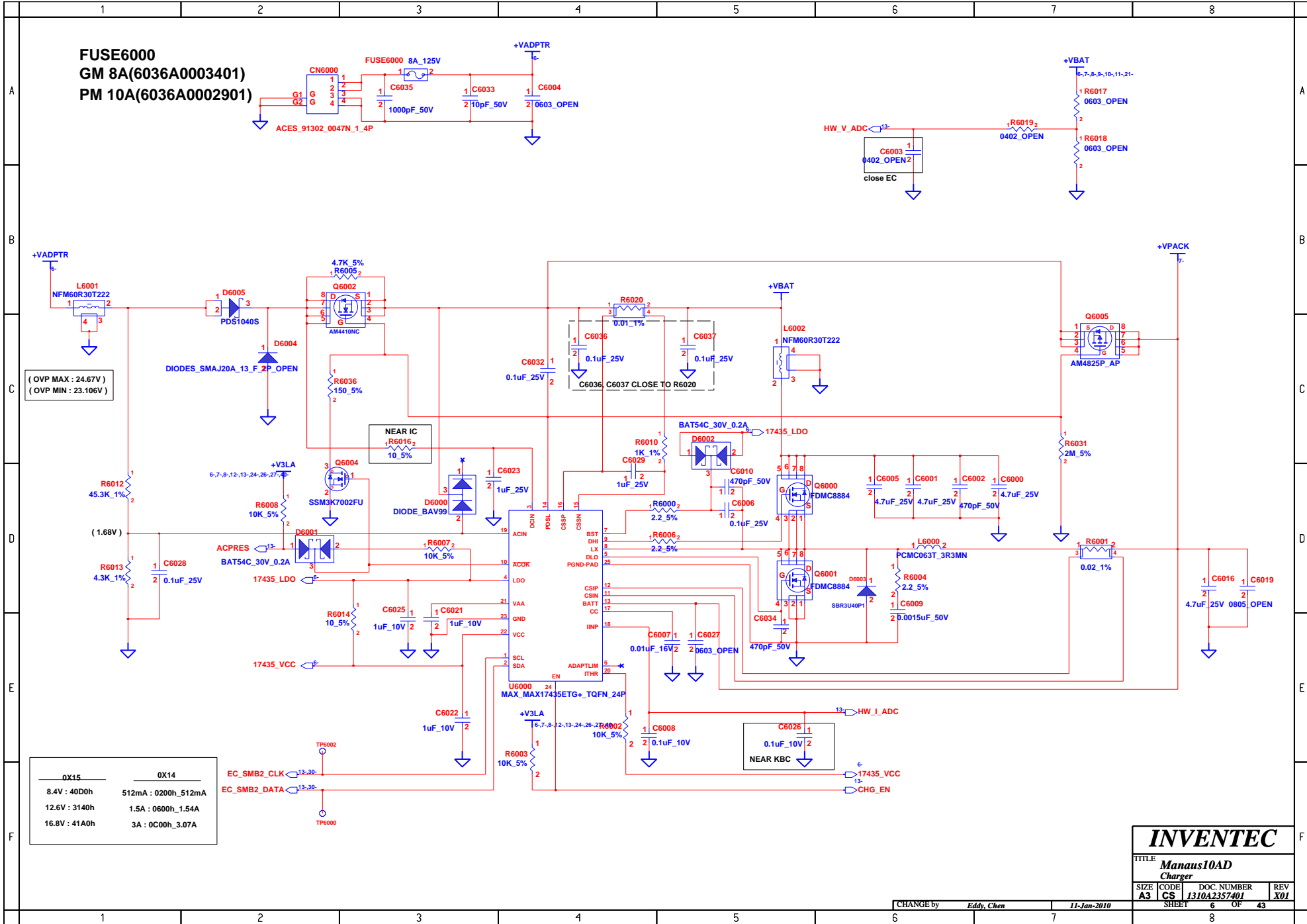

FUSE6000
GM 8A(6036A0003401)
PM 10A(6036A0002901)

(OVP MAX : 24.67V)
(OVP MIN : 23.106V)

0X15	0X14
8.4V : 40D0h	512mA : 0200h_512mA
12.6V : 3140h	1.5A : 0600h_1.54A
16.8V : 41A0h	3A : 0C00h_3.07A

EC_SMB2_CLK 13-30
EC_SMB2_DATA 13-30

INVENTEC

TITLE
Mana10AD
Charger

SIZE A3	CODE CS	DOC. NUMBER 1310A2357401	REV X01
SHEET 6		OF 43	

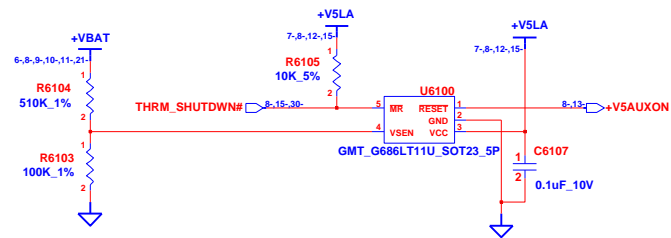
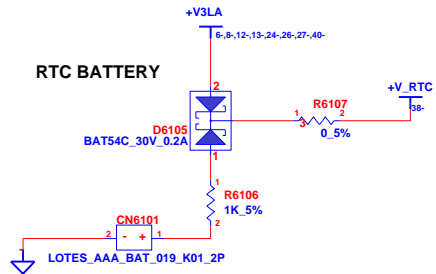
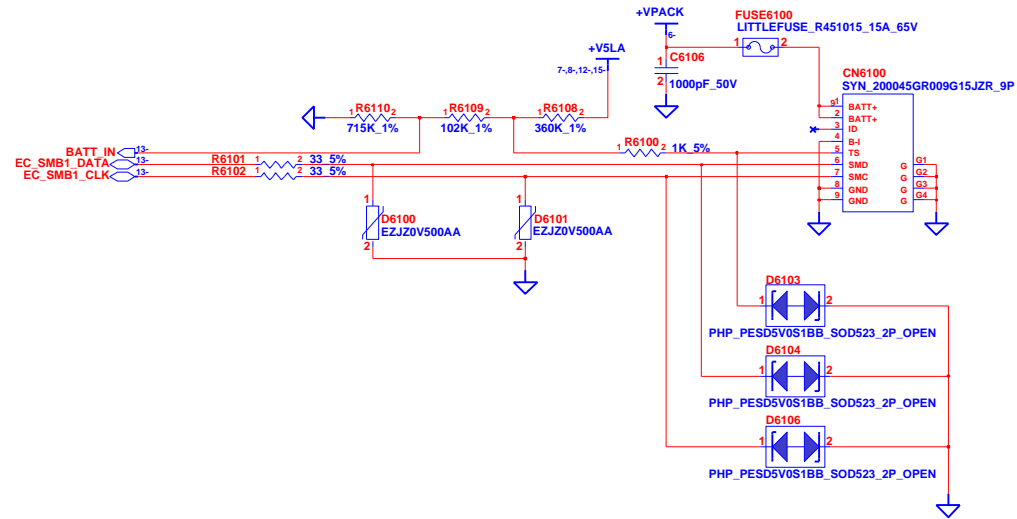

INVENTEC

TITLE			
Manaus10AD			
Battery, Reset IC			
SIZE	CODE	DOC NUMBER	REV
A3	CS	1310A2357401	X01
CHANGE by		SHEET	
Eddy, Chen		7 OF 43	

11-Jan-2010

+V3LA +V3A +V5A +V2.5S

A

B

C

D

E

F

A

B

C

D

E

F

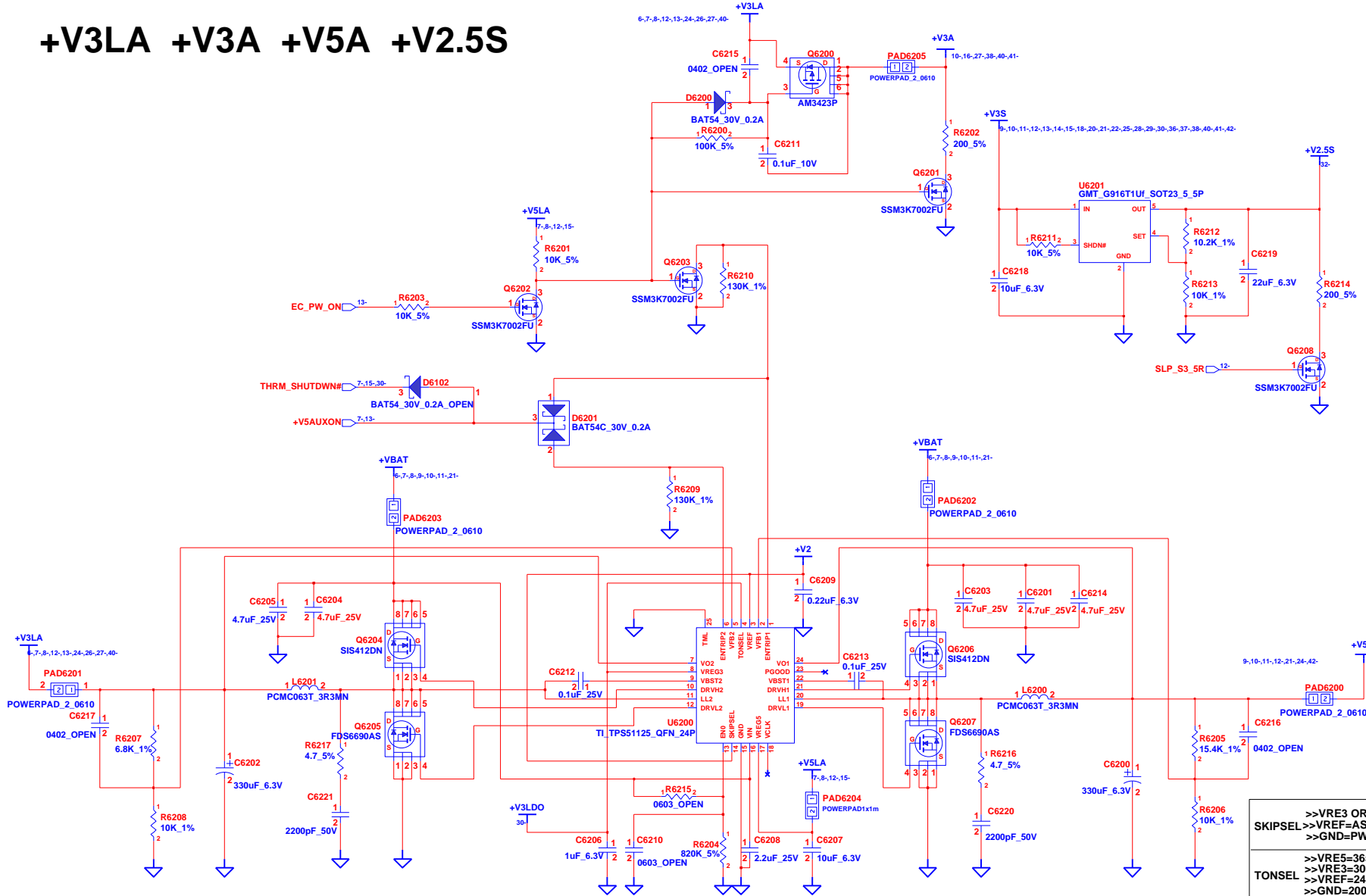

>>VRE3 OR VRE5=OOA
 SKIPSEL>>VREF=ASKIP
 >>GND=PWM
 >>VRE5=365/460
 >>VRE3=300/375
 TONSEL >>VREF=245/305
 >>GND=200/250

INVENTEC			
TITLE Manaus10AD			
+V3LA, +V3A, +V5A, +V2.5S			
SIZE	CODE	DOC NUMBER	REV
A3	CS	1310A2357401	X01
CHANGE by		SHEET	
Eddy, Chen		8 OF 43	

11-Jan-2010

+CPU_VDDR +V0.75 +V1.5

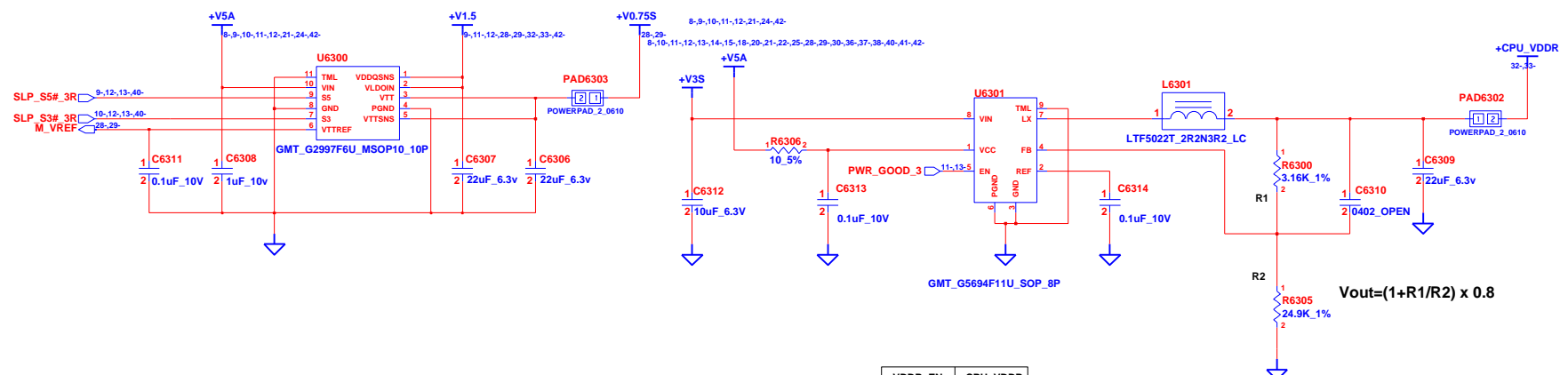
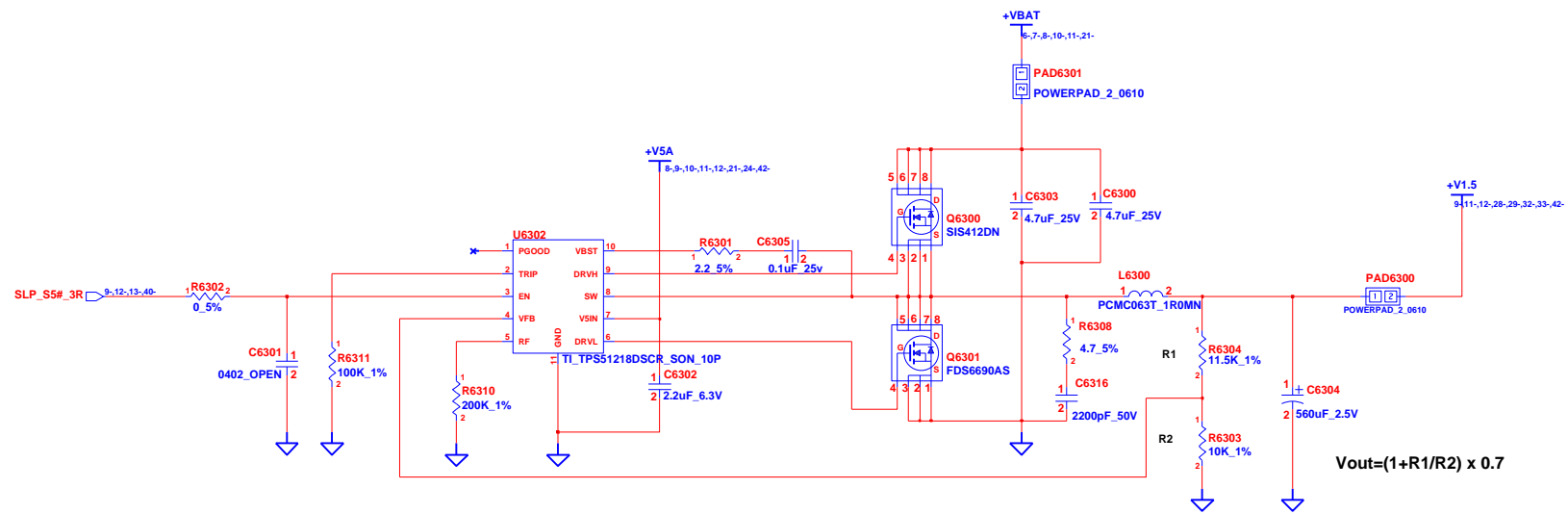

VDDR_EN	+CPU_VDDR
0	0.9V
1	1.05V

INVENTEC

TITLE
Manaus10AD
+CPU_VDDR, +V0.75, +V1.5

SIZE A3	CODE CS	DOC NUMBER 1310A2337401	REV X01
SHEET 9		OF 43	

+V1.1A +V1.1S +V1.8S

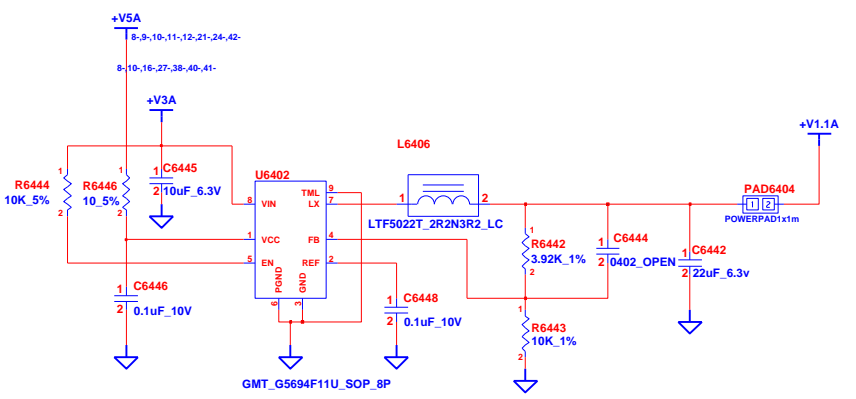
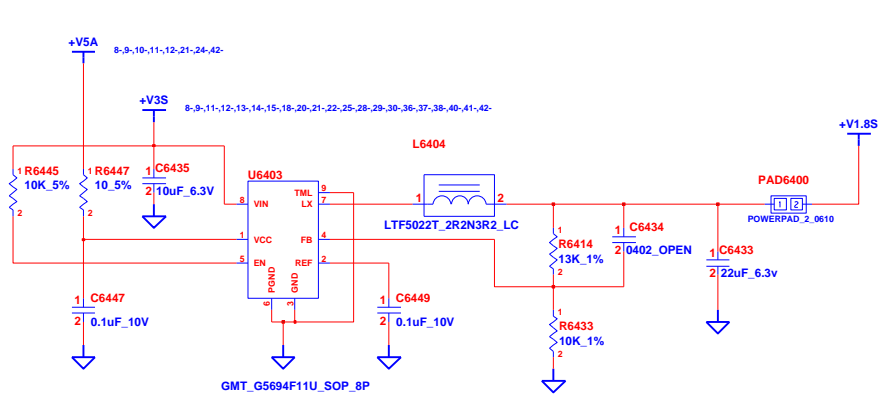
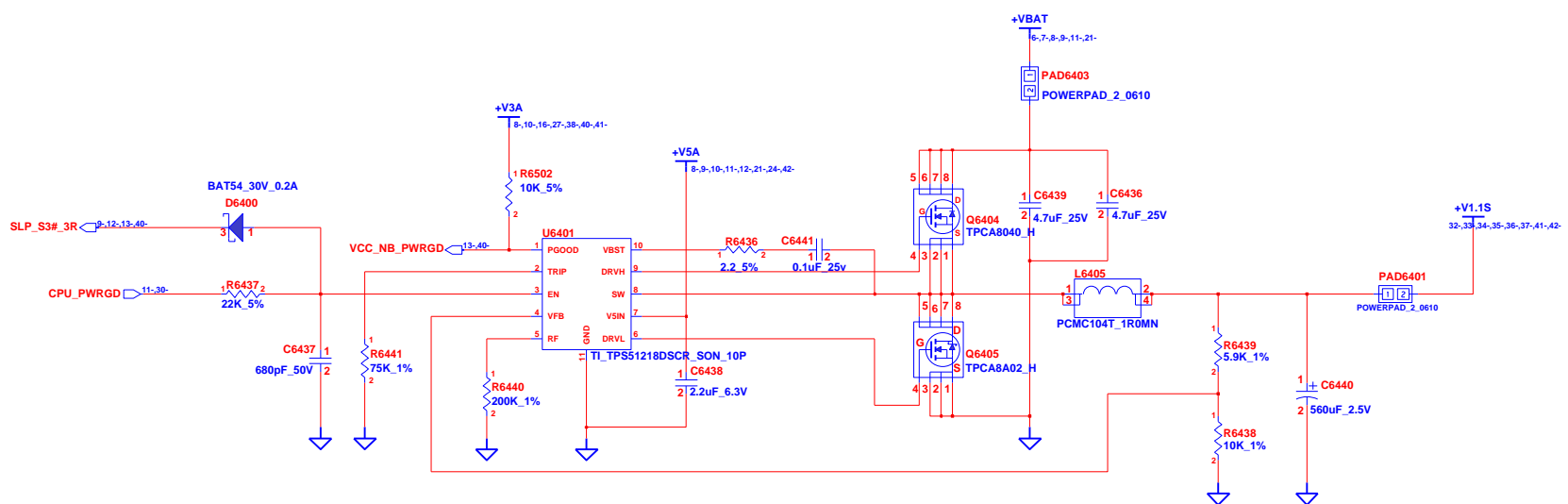

INVENTEC			
TITLE Manaus10AD			
+V1.1A, +V1.1S, +V1.8S			
SIZE A3	CODE CS	DOC NUMBER 1310A2337401	REV X01
CHANGE by <i>Eddy, Chen</i>		11-Jan-2010	
SHEET 10		OF 43	

SVC	SVD	VDD_CORE
0	0	1.1V
0	1	1.0V
1	0	0.9V
1	1	0.8V

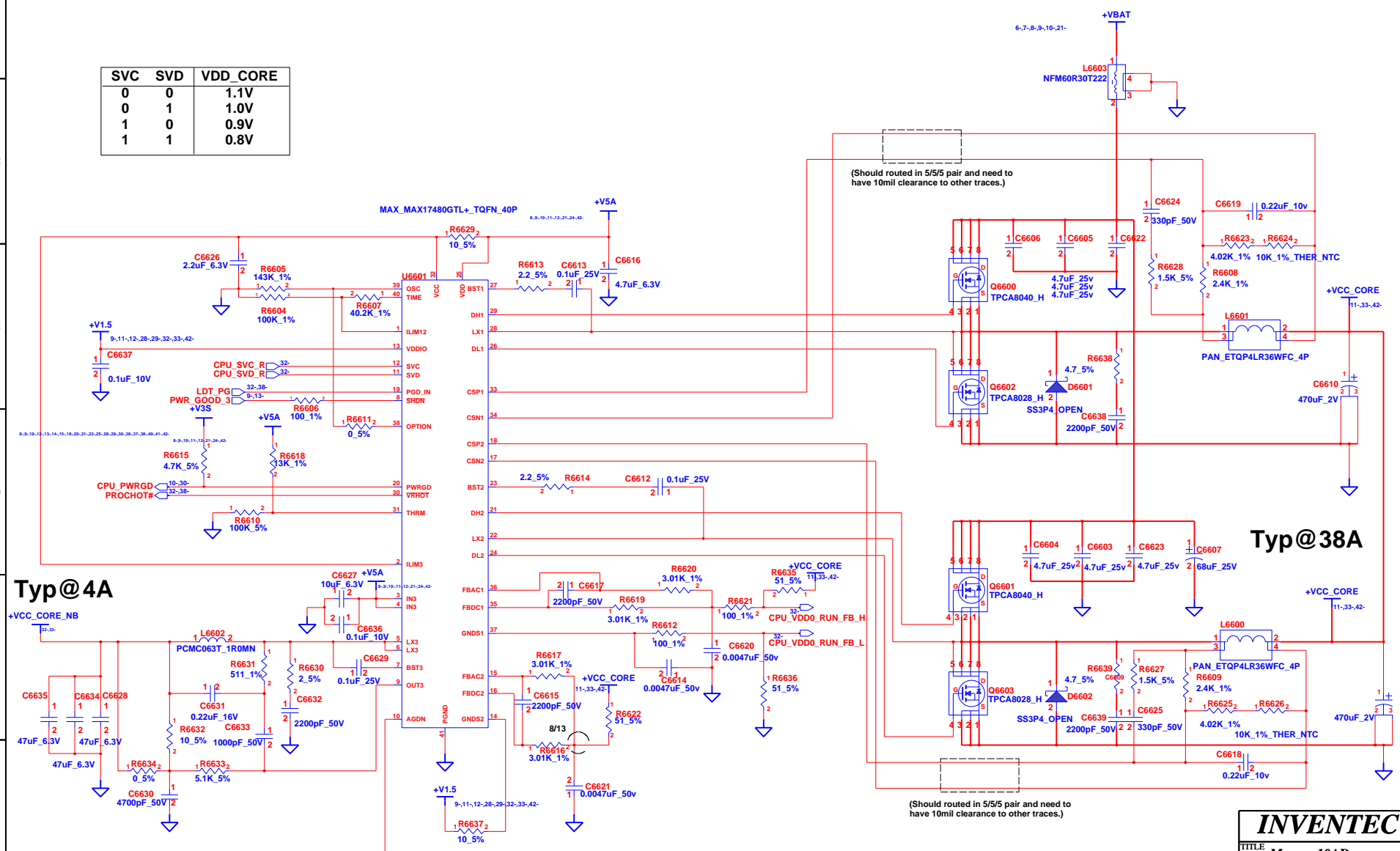

INVENTEC			
TITLE Manaus10AD			
+VCC_CORE, +VCC_CORE_NB			
SIZE A3	CODE CS	DOC NUMBER 1310A2337401	REV X01
CHANGE by <i>Eddy, Chen</i>		11-Jan-2010	
SHEET 11		OF 43	

+V5S +V3S +V1.5S

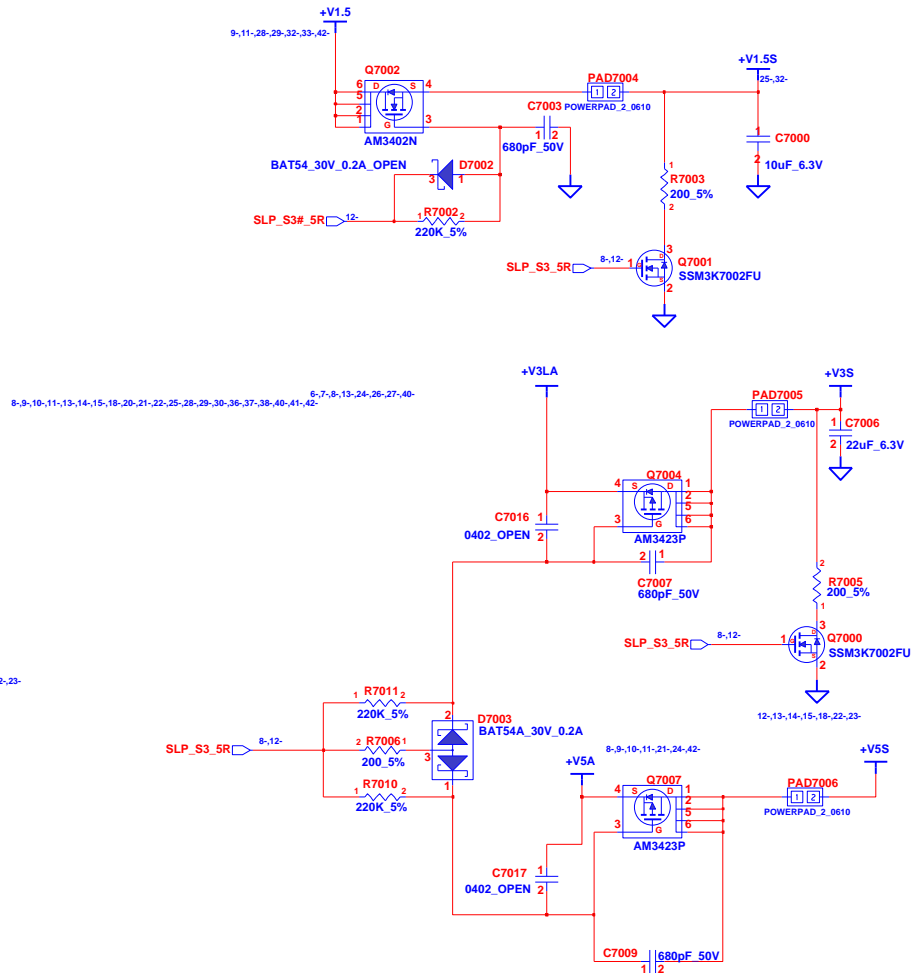
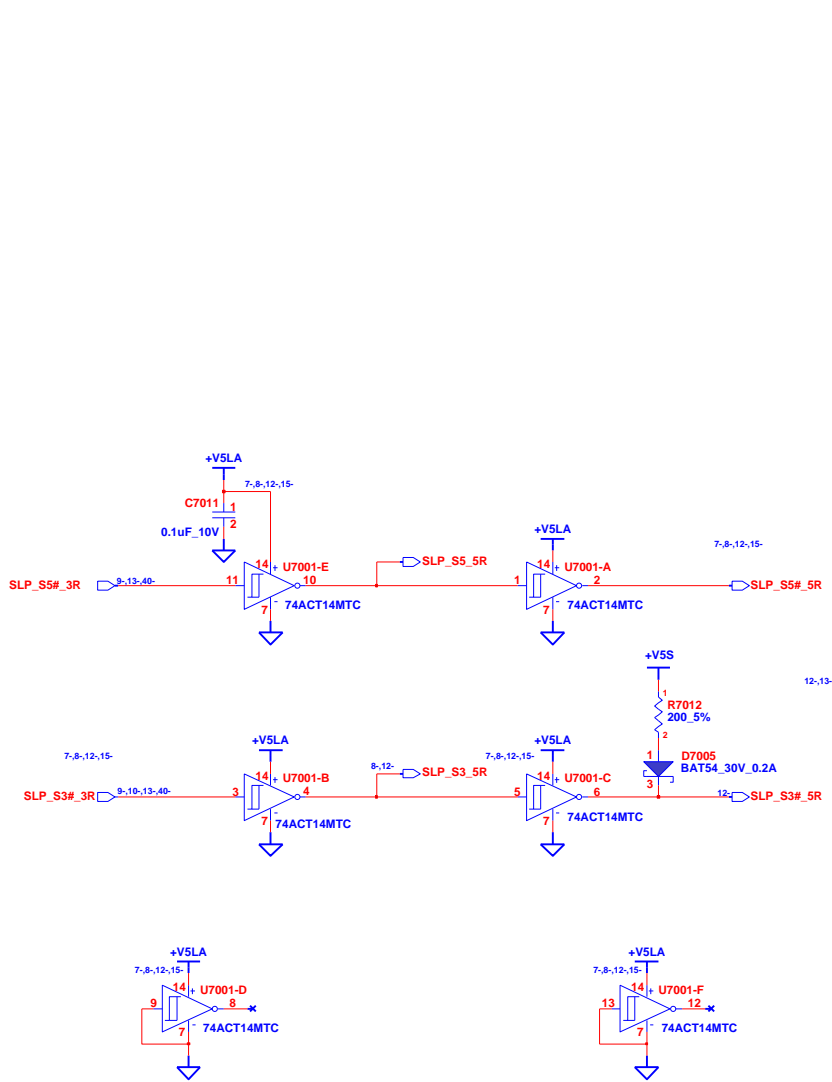

INVENTEC			
TITLE Manaus10AD			
+V3 +V5S +V3S +V1.5S			
SIZE A3	CODE CS	DOC NUMBER 1310A2357401	REV X01
CHANGE by Eddy, Chen		11-Jan-2010	
SHEET 12		OF 43	

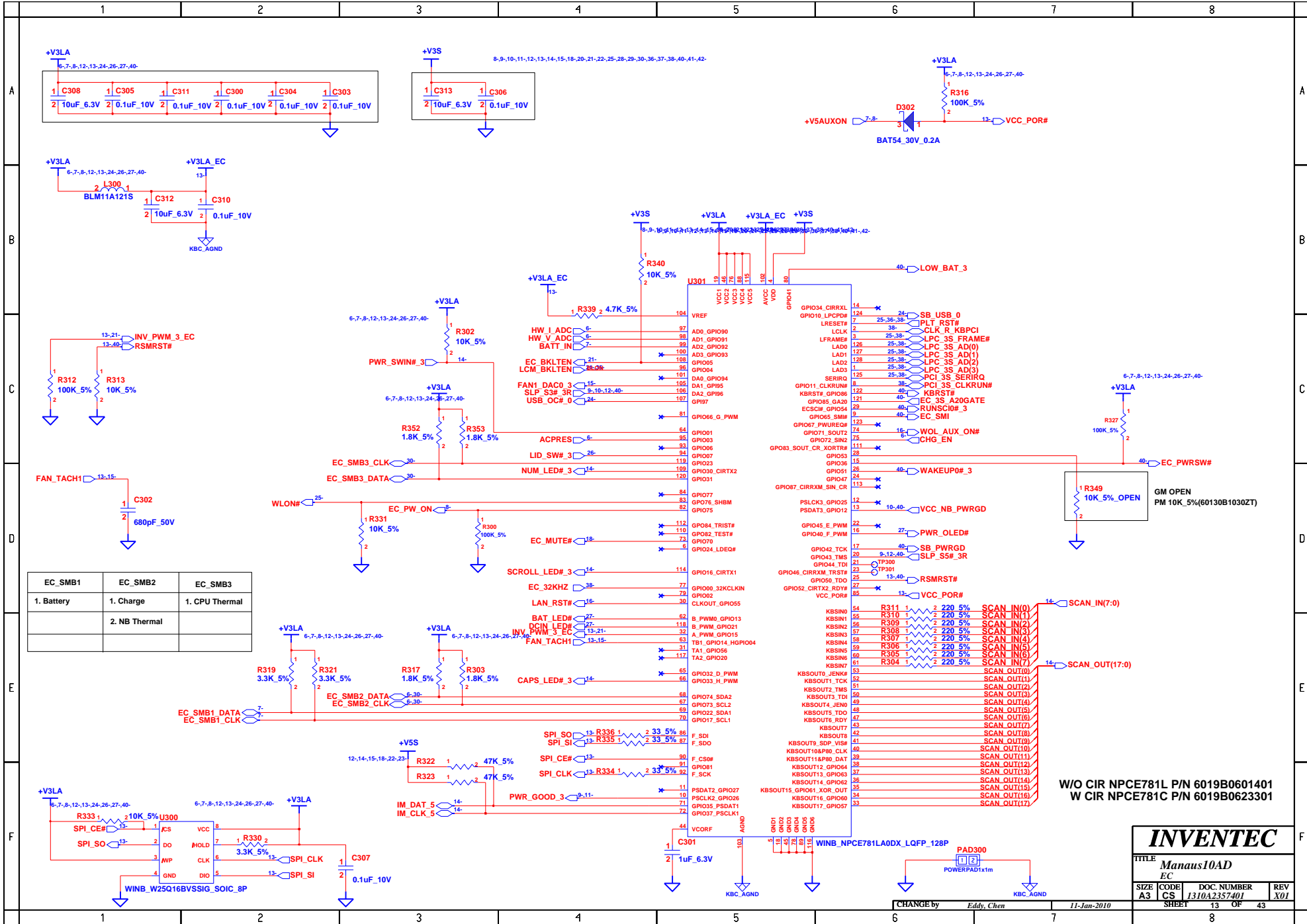

EC_SMB1	EC_SMB2	EC_SMB3
1. Battery	1. Charge	1. CPU Thermal
	2. NB Thermal	

W/O CIR NPCE781L P/N 6019B0601401
 W CIR NPCE781C P/N 6019B0623301

INVENTEC			
TITLE <i>Manaus10AD</i> EC			
SIZE A3	CODE CS	DOC NUMBER 1310A2357401	REV X01
CHANGE by Eddy, Chen		11-Jan-2010	
SHEET		13	OF 43

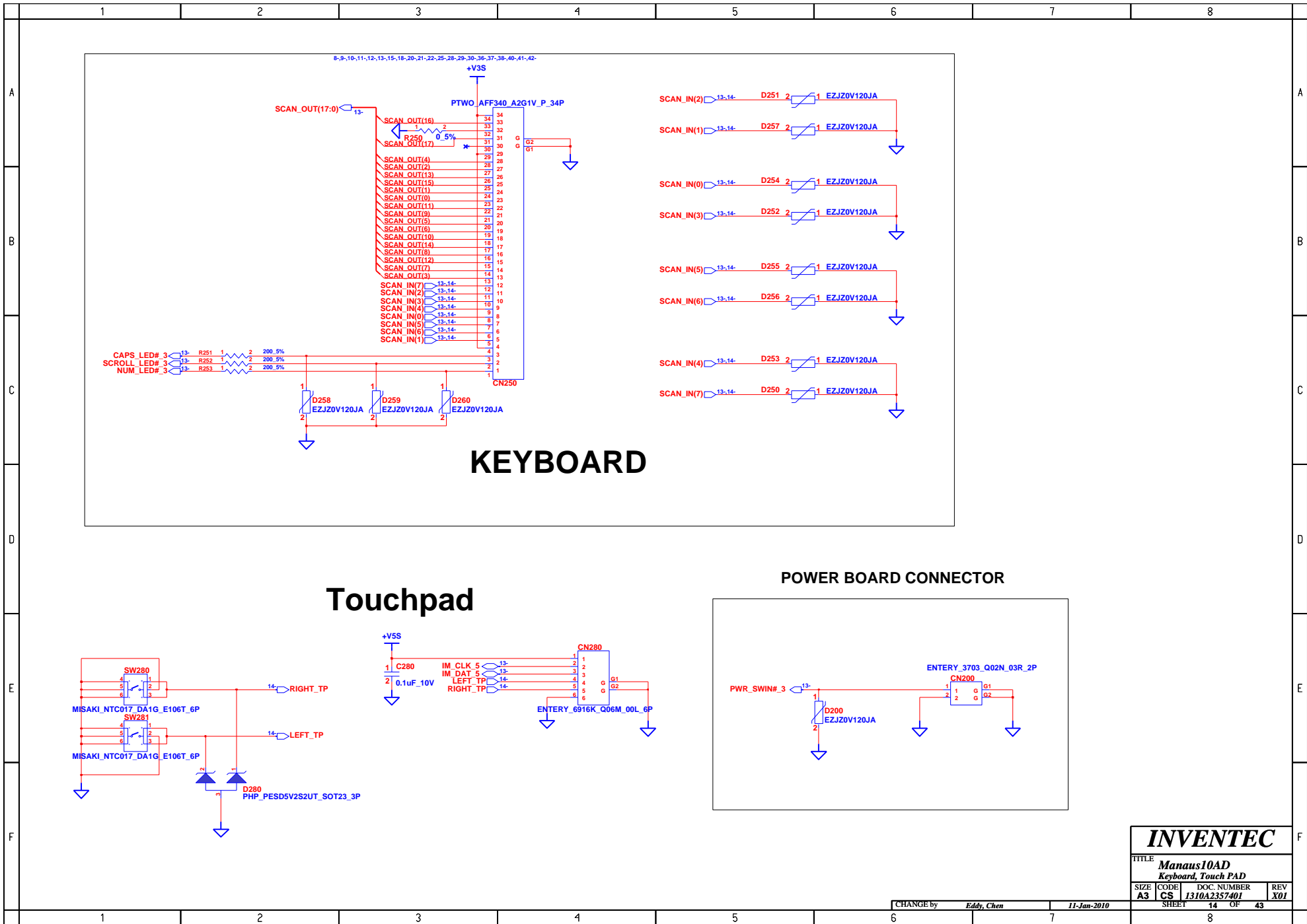

INVENTEC			
TITLE Manaus10AD Keyboard, Touch PAD			
SIZE A3	CODE CS	DOC. NUMBER 1310A2337401	REV X01
CHANGE by <i>Eddy, Chen</i>		11-Jan-2010	
SHEET 14		OF 43	

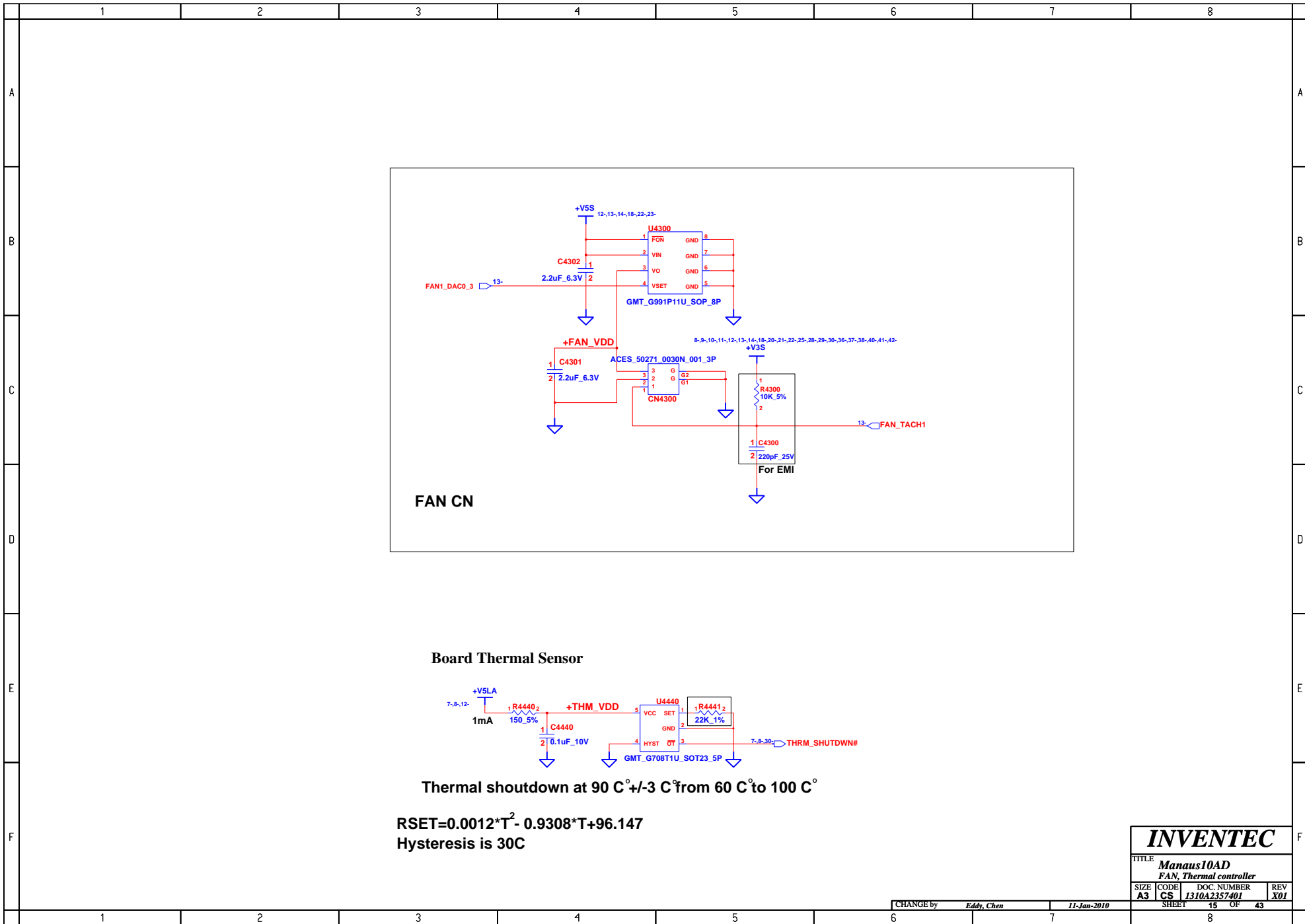

FAN CN

Board Thermal Sensor

Thermal shutdown at 90 C° +/-3 C° from 60 C° to 100 C°

$$RSET=0.0012*T^2 - 0.9308*T+96.147$$

Hysteresis is 30C

INVENTEC			
TITLE Manaus10AD FAN, Thermal controller			
SIZE A3	CODE CS	DOC. NUMBER 1310A2357401	REV X01
CHANGE by <i>Eddy, Chen</i>		11-Jan-2010	
SHEET		15	OF 43

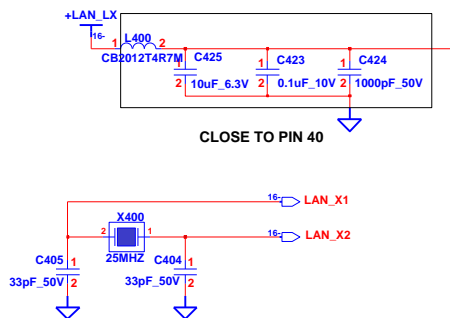
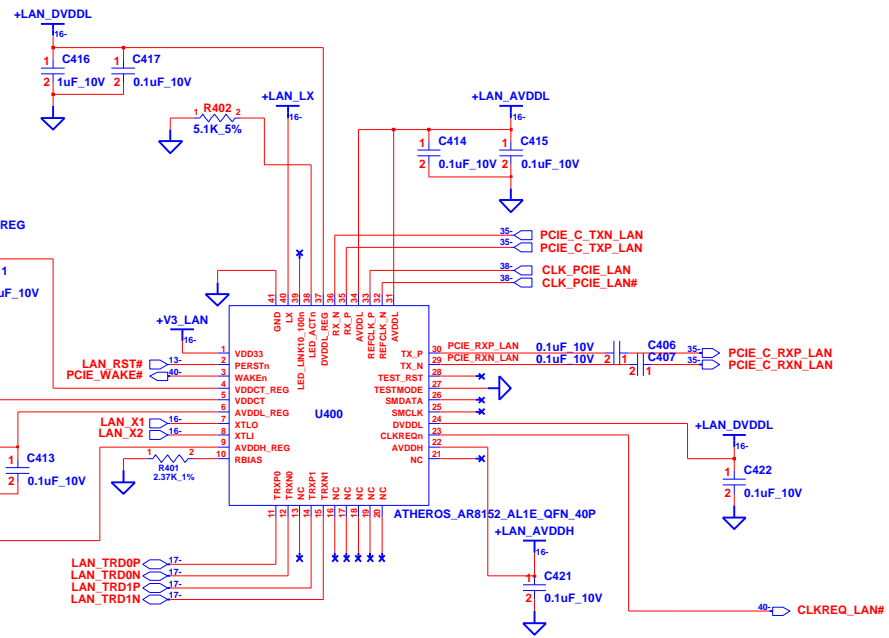
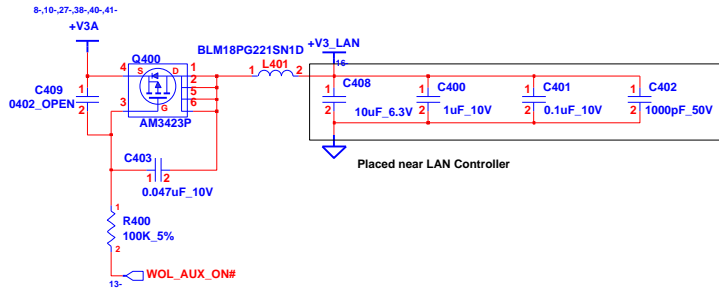

INVENTEC

TITLE
Manaus10AD
LAN

SIZE CODE CS DOC. NUMBER REV
A3 **CS** **1310A2357401** **X01**

CHANGE by *Eddy, Chen* 11-Jan-2010 SHEET 16 OF 43

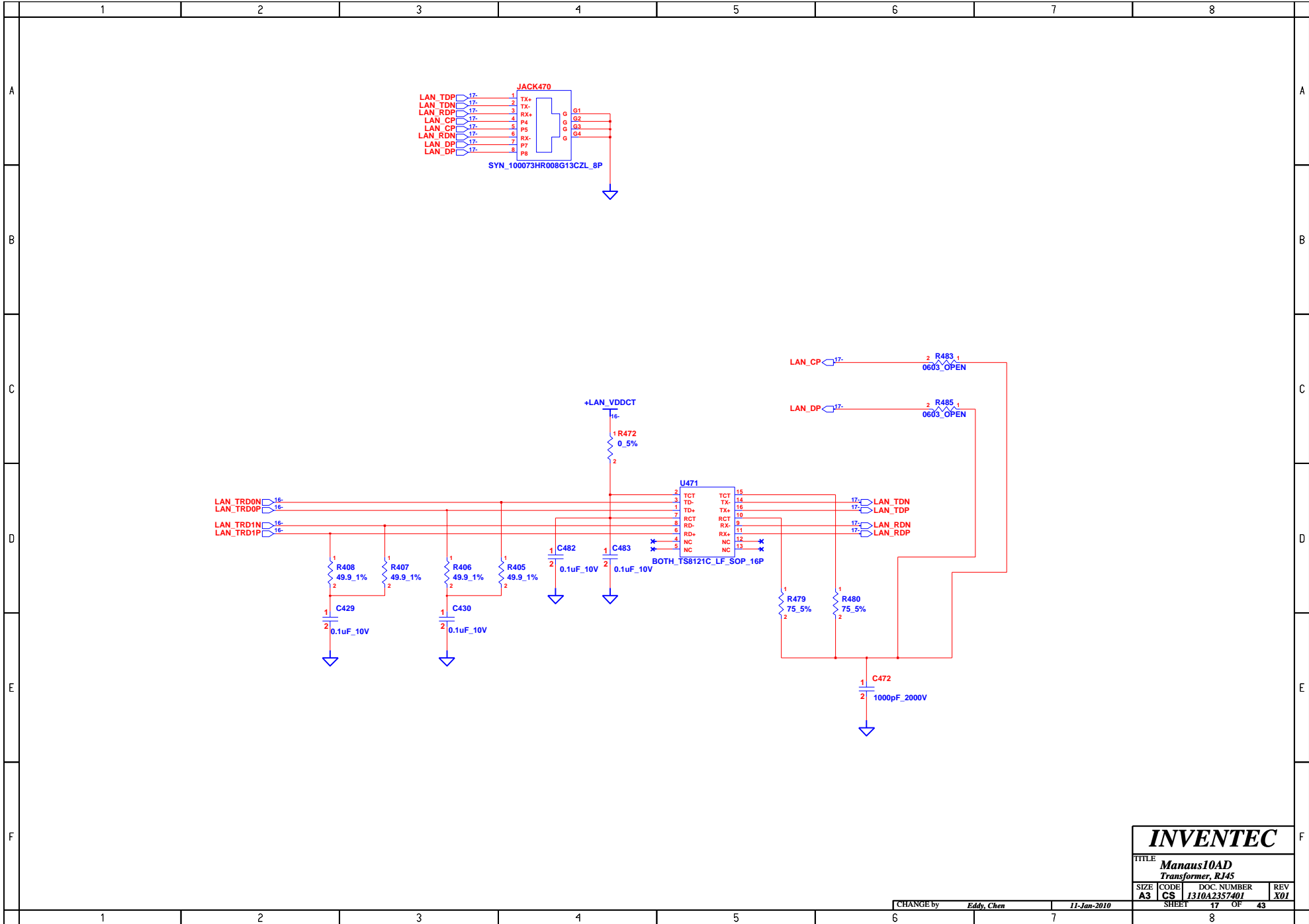

INVENTEC

TITLE
Manaus10AD
 Transformer, RJ45

SIZE	CODE	DOC. NUMBER	REV
A3	CS	1310A2337401	X01
SHEET		17	OF 43

CHANGE by *Eddy, Chen* 11-Jan-2010

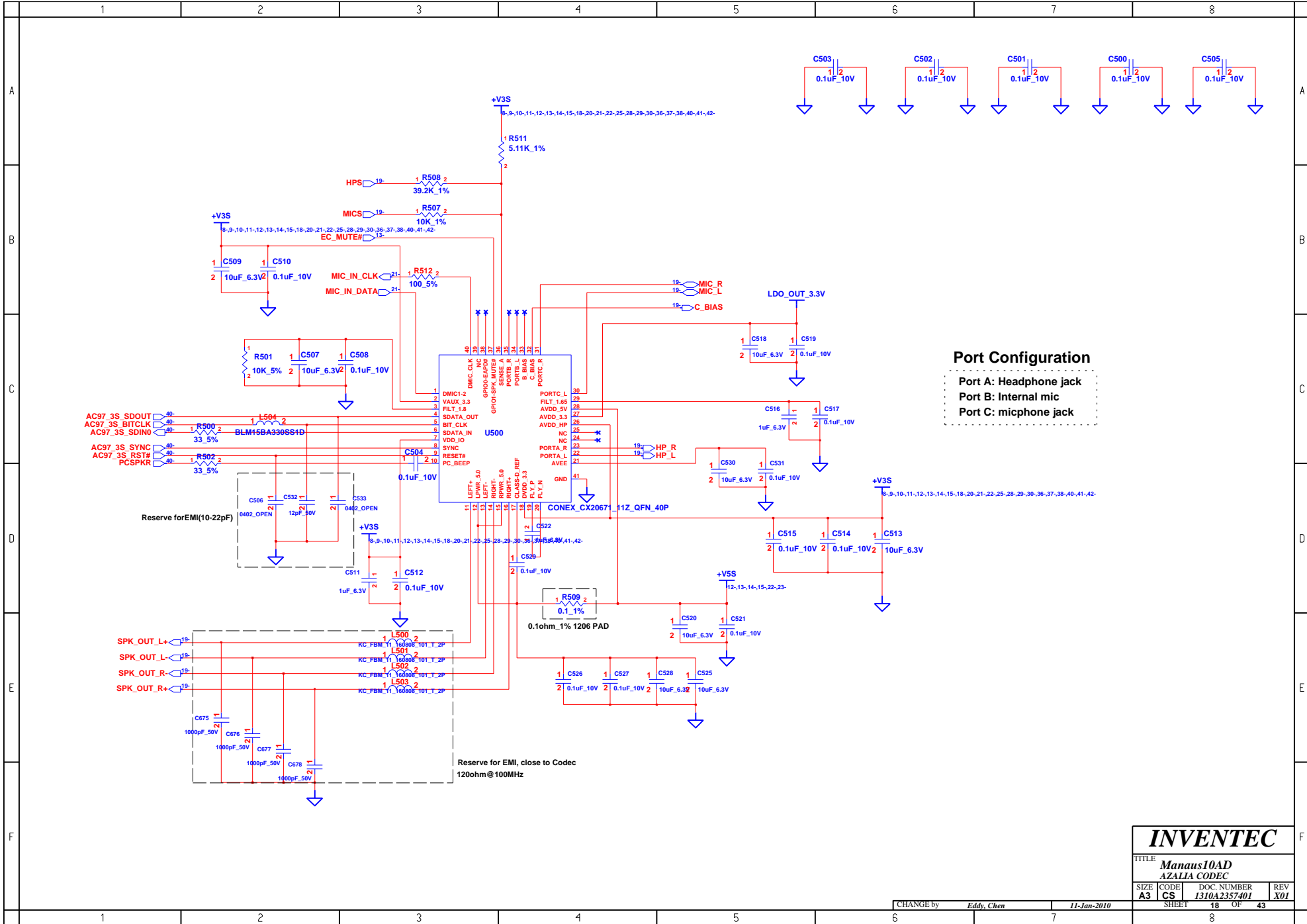

Port Configuration

- Port A: Headphone jack
- Port B: Internal mic
- Port C: microphone jack

INVENTEC

TITLE
Mana10AD
AZALIA CODEC

SIZE A3	CODE CS	DOC. NUMBER 1310A2357401	REV X01
-------------------	-------------------	------------------------------------	-------------------

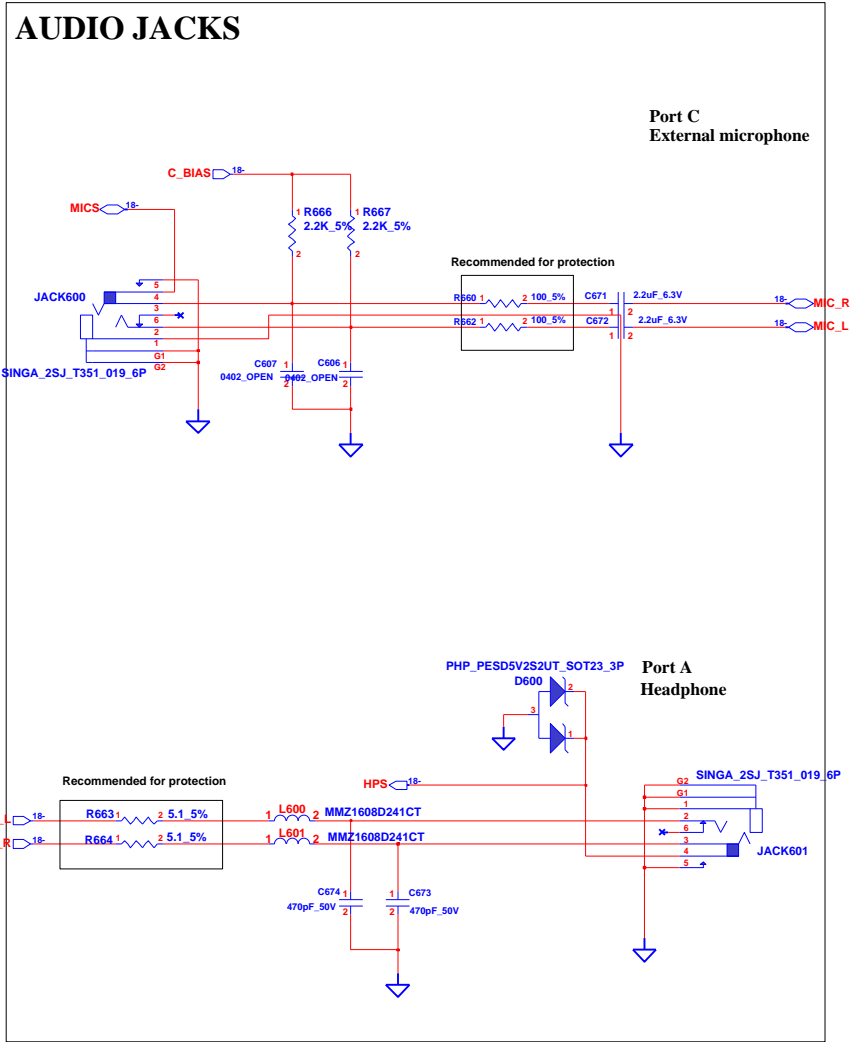
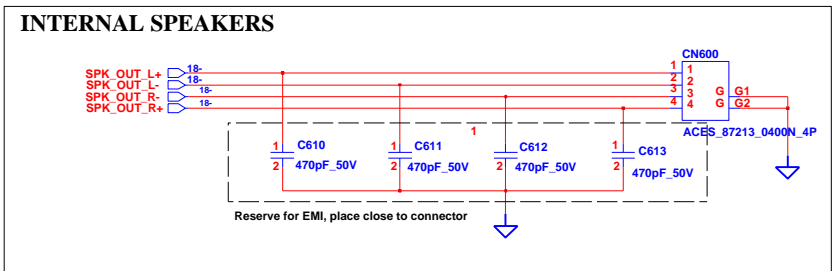

INVENTEC			
TITLE <i>Manaus10AD</i> MIC & SPEAKER			
SIZE A3	CODE CS	DOC. NUMBER <i>1310A2357401</i>	REV X01
CHANGE by <i>Eddy, Chen</i>		11-Jan-2010	
SHEET		19 OF 43	

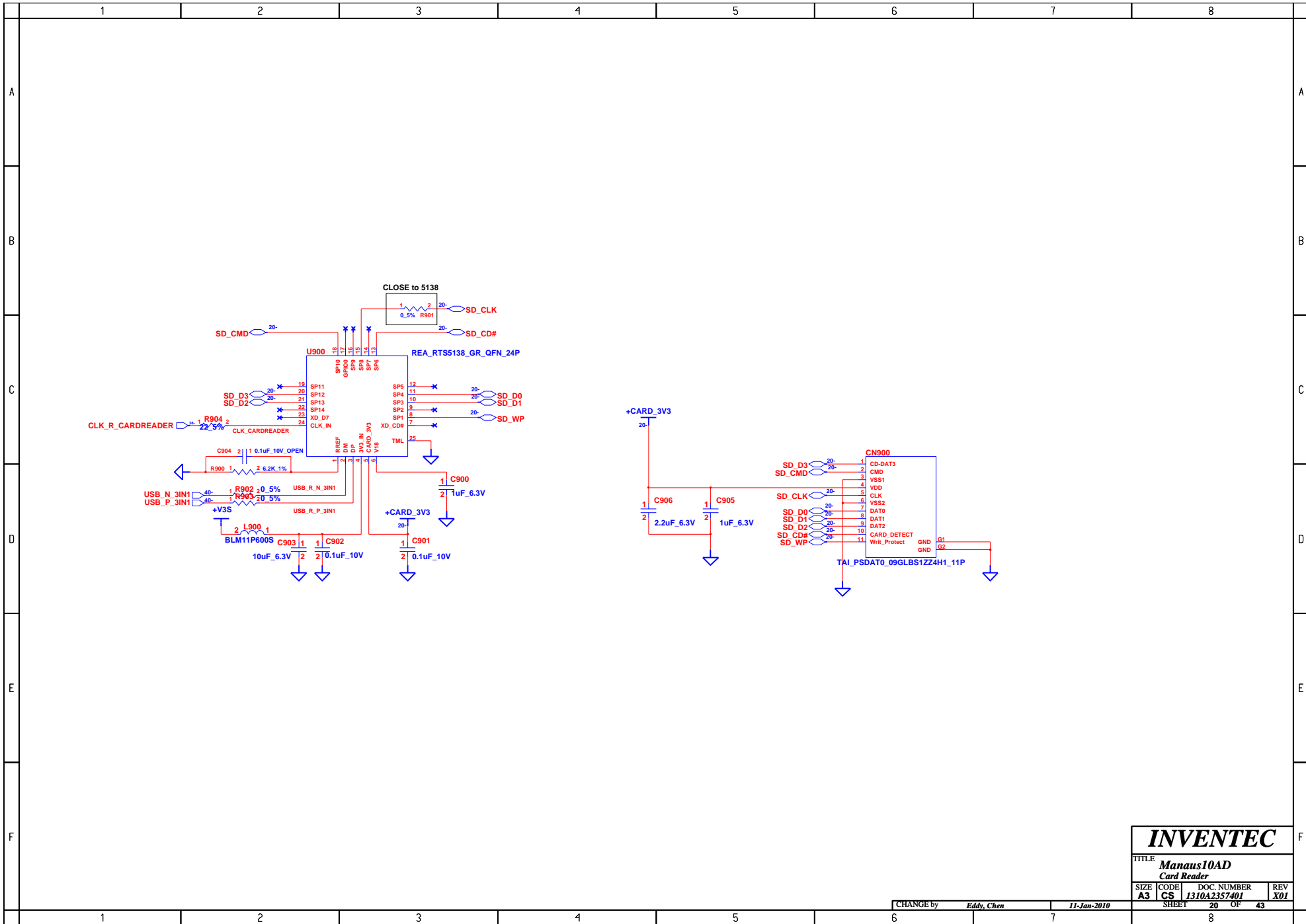

INVENTEC

TITLE
Mana10AD
 Card Reader

SIZE A3	CODE CS	DOC. NUMBER 1310A2357401	REV X01
SHEET		20 OF	43

CHANGE by *Eddy, Chen* 11-Jan-2010

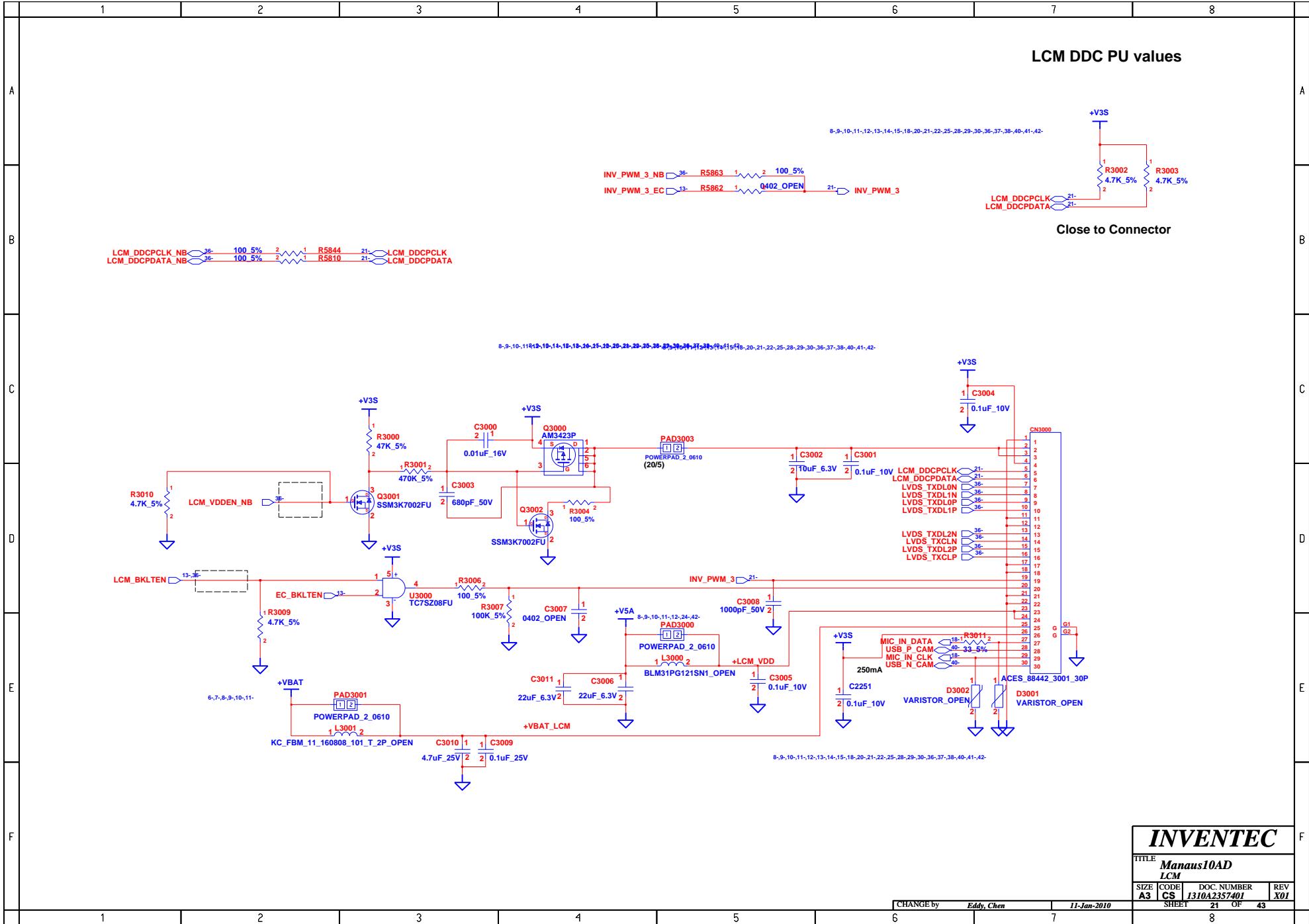

LCM DDC PU values

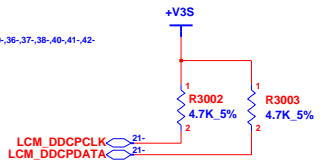

INVENTEC

TITLE			
Manaus10AD			
LCM			
SIZE	CODE	DOC. NUMBER	REV
A3	CS	1310A2357401	X01
SHEET		21 OF	43

CHANGE by Eddy, Chen 11-Jan-2010

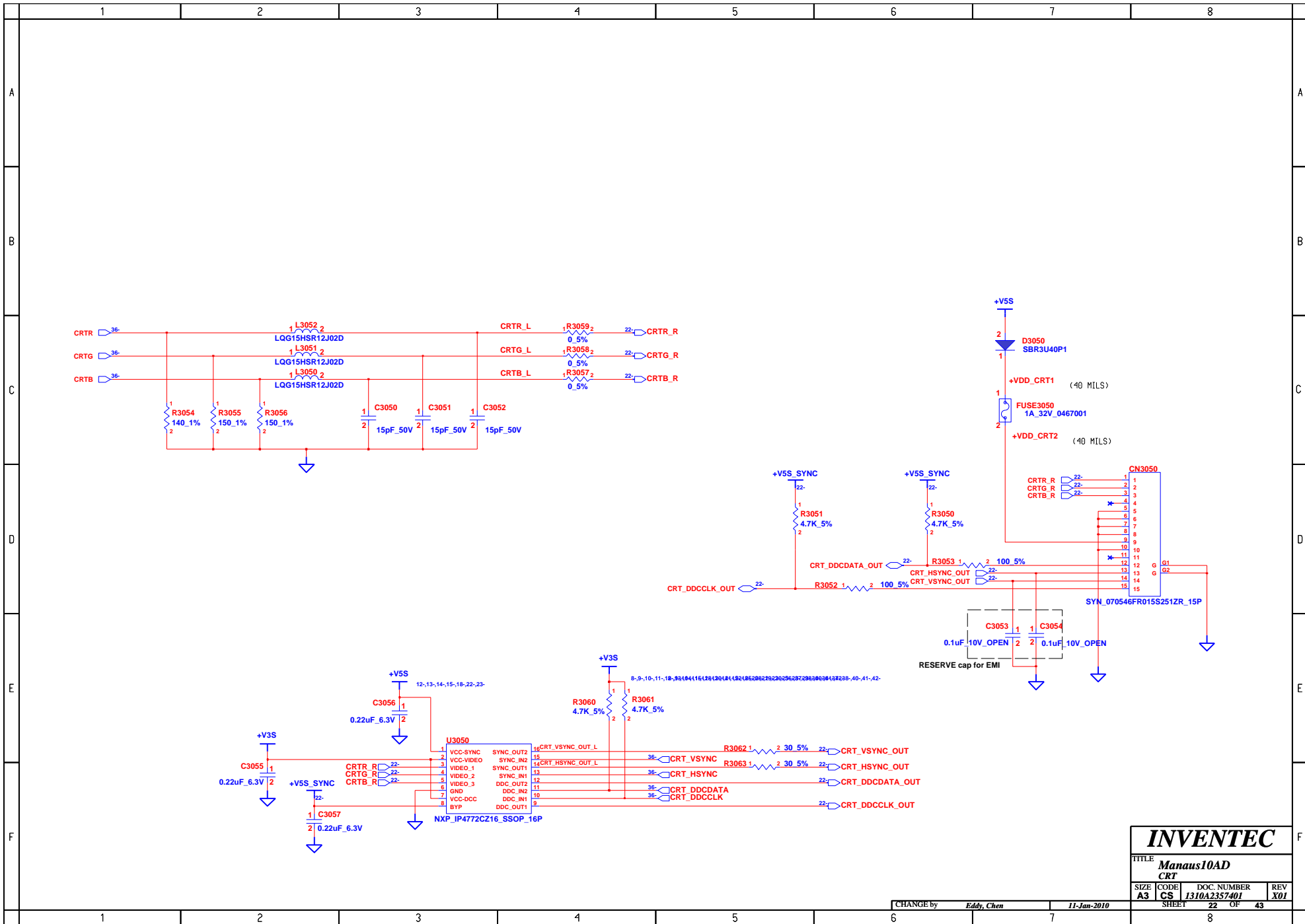

INVENTEC			
TITLE Manaus10AD CRT			
SIZE A3	CODE CS	DOC. NUMBER 1310A2337401	REV X01
CHANGE by <i>Eddy, Chen</i>		11-Jan-2010	
SHEET 22 OF 43		8	

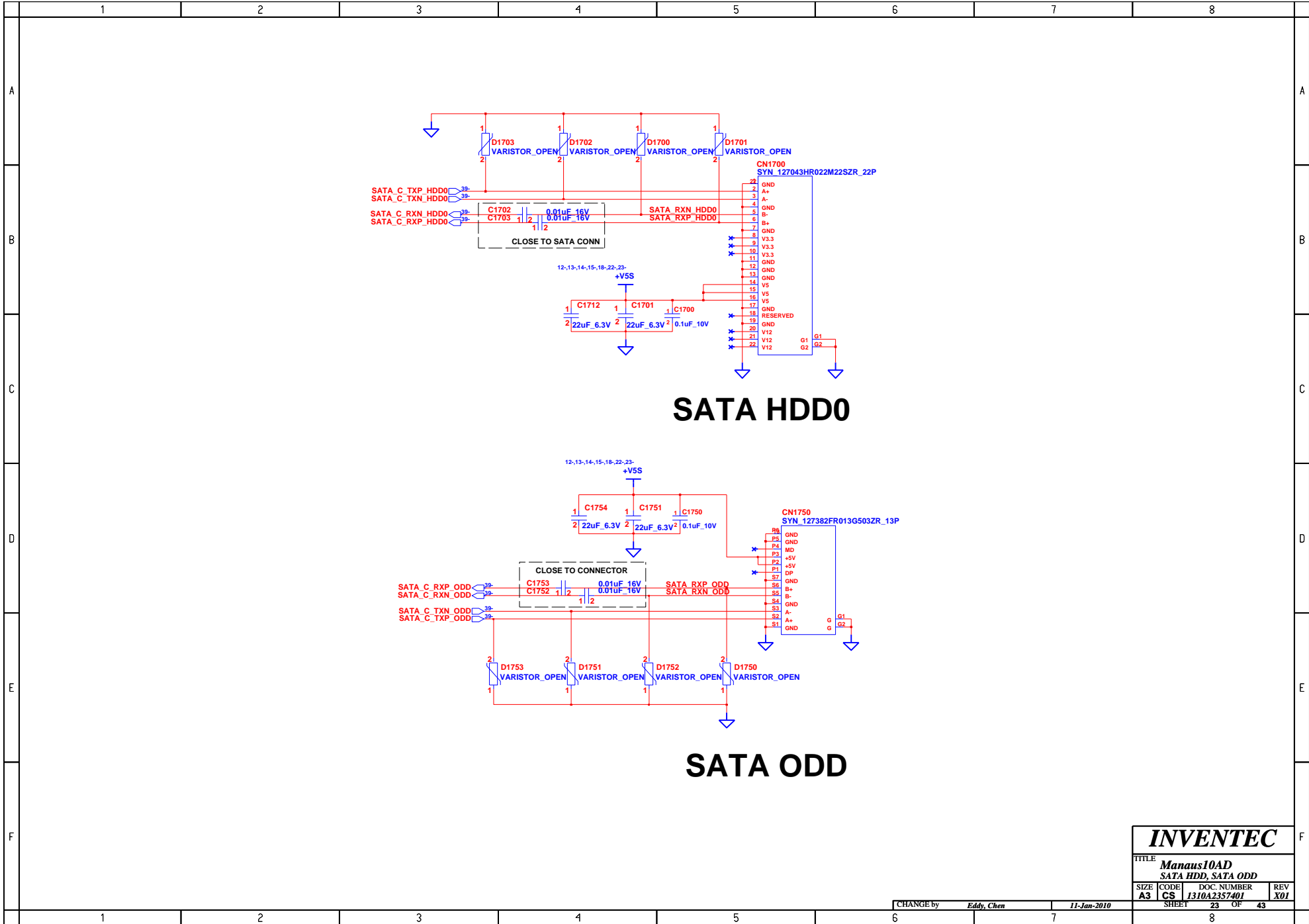

INVENTEC

TITLE			
Manaus10AD			
SATA HDD, SATA ODD			
SIZE	CODE	DOC. NUMBER	REV
A3	CS	1310A2357401	X01
SHEET		23 OF	43

CHANGE by Eddy, Chen 11-Jan-2010

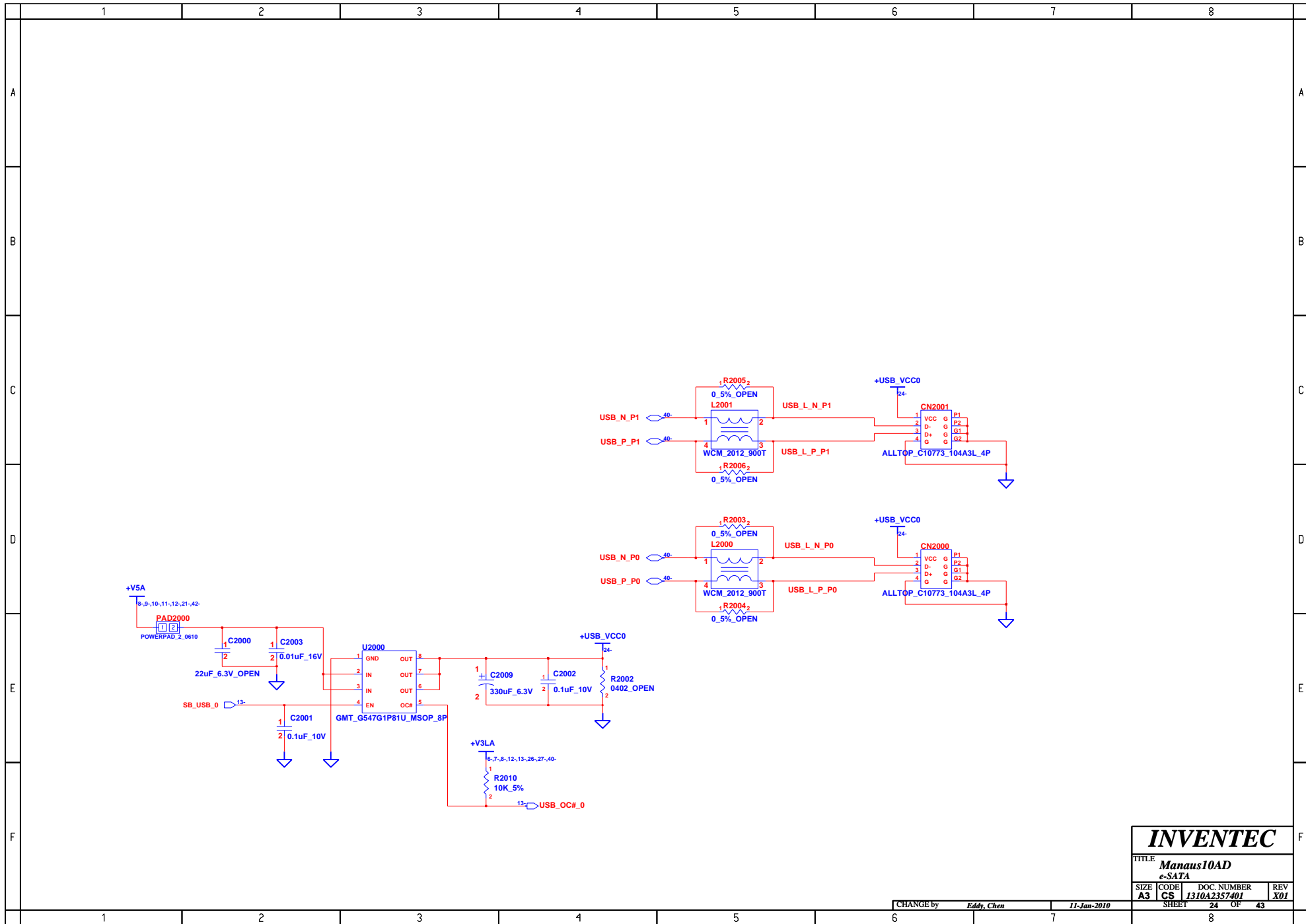

INVENTEC

TITLE
Manaus10AD
 e-SATA

SIZE A3	CODE CS	DOC. NUMBER 1310A2357401	REV X01
-------------------	-------------------	------------------------------------	-------------------

Wireless & Debug card

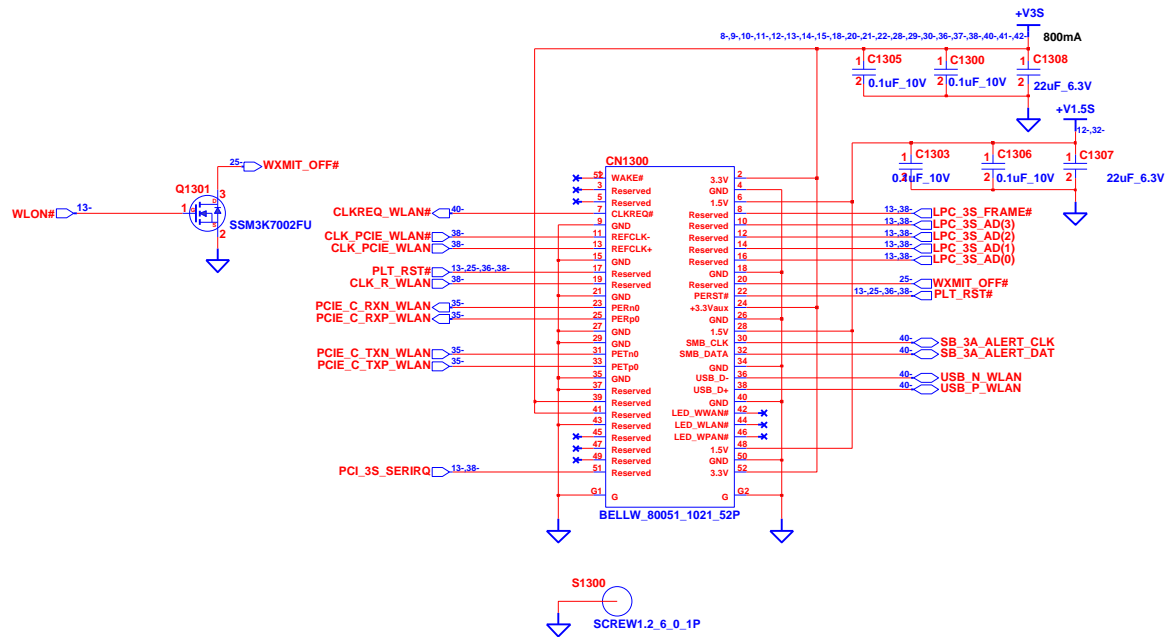

INVENTEC

TITLE			
Manaus10AD			
WLAN			
SIZE	CODE	DOC. NUMBER	REV
A3	CS	1310A2357401	X01
SHEET		25 OF	43

CHANGE by Eddy, Chen 11-Jan-2010

HALL SENSOR

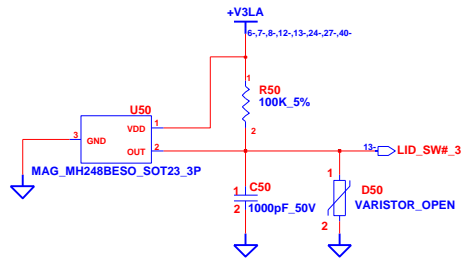

INVENTEC

TITLE			
Manaus10AD			
HALL SENSOR			
SIZE	CODE	DOC. NUMBER	REV
A3	CS	1310A2357401	X01
SHEET		26	OF 43

CHANGE by Eddy, Chen 11-Jan-2010

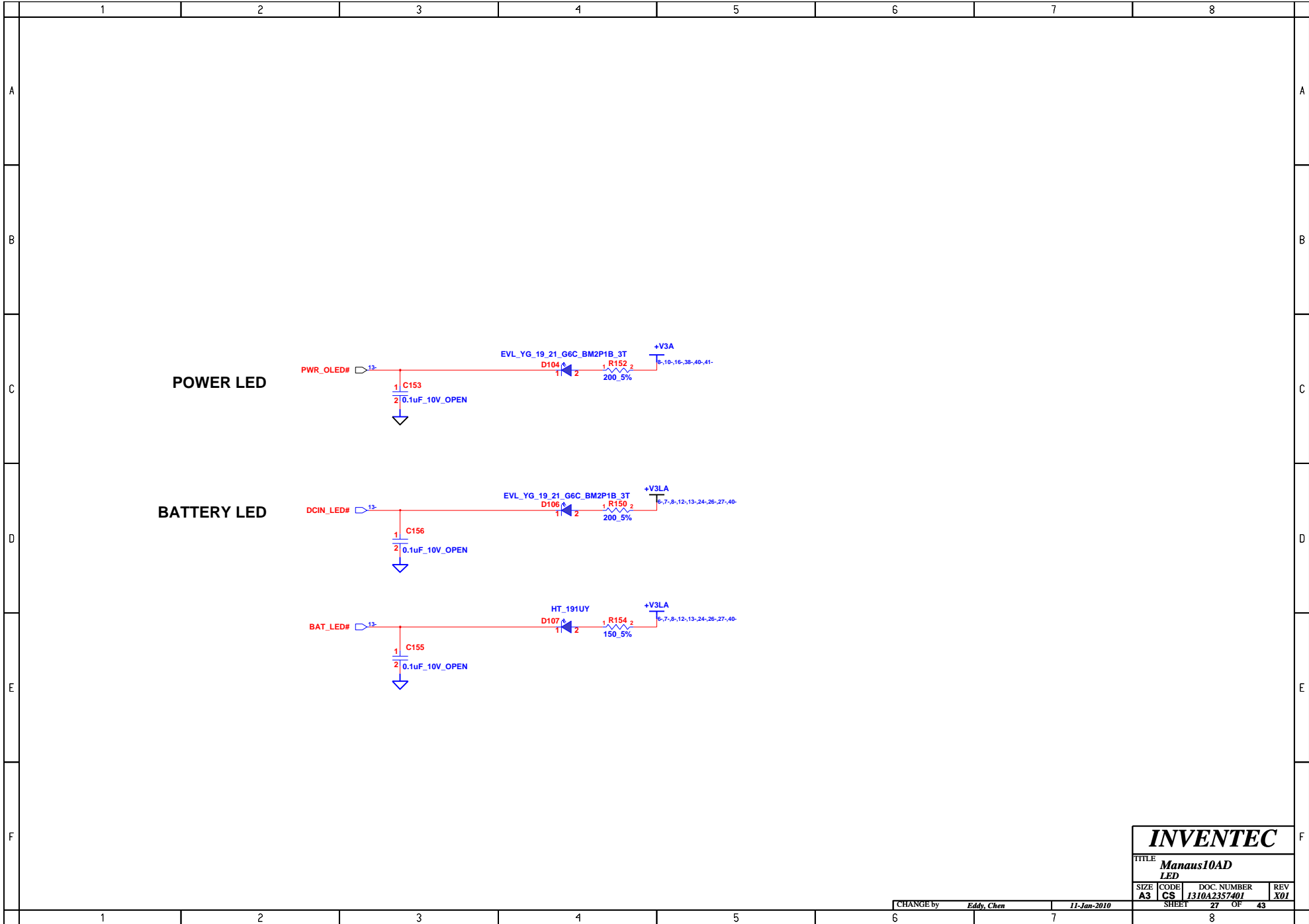

INVENTEC

TITLE			
Manaus10AD			
LED			
SIZE	CODE	DOC. NUMBER	REV
A3	CS	1310A2357401	X01
SHEET		27	OF 43

CHANGE by Eddy, Chen 11-Jan-2010

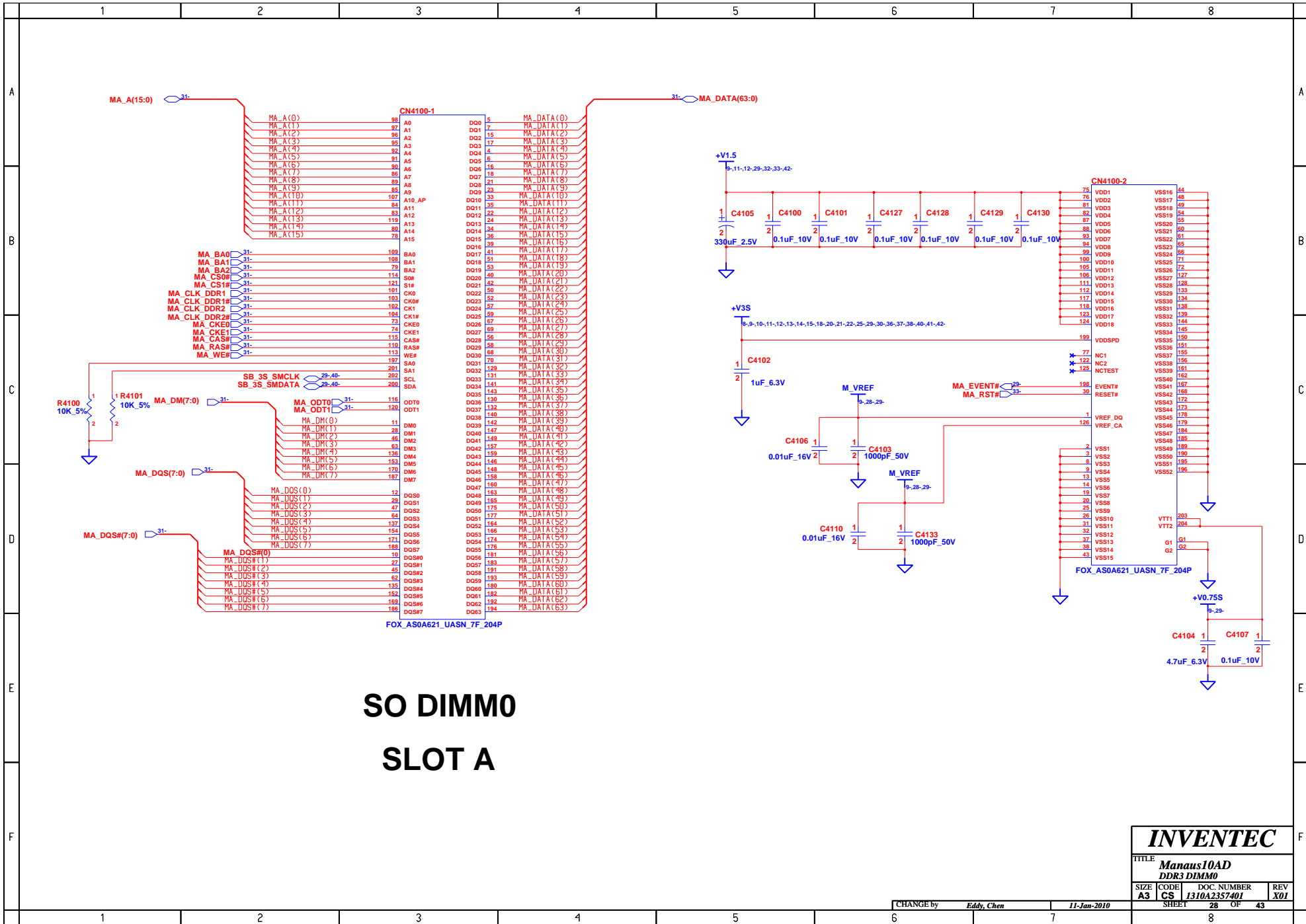

SO DIMM0 SLOT A

INVENTEC				
TITLE				
Manaus10AD DDR3 DIMM0				
SIZE	CODE	DOC. NUMBER	REV	
A3	CS	1310A2357401	28	X01
CHANGE by <i>Eddy, Chen</i> 11-Jan-2010				
SHEET			28	OF 43

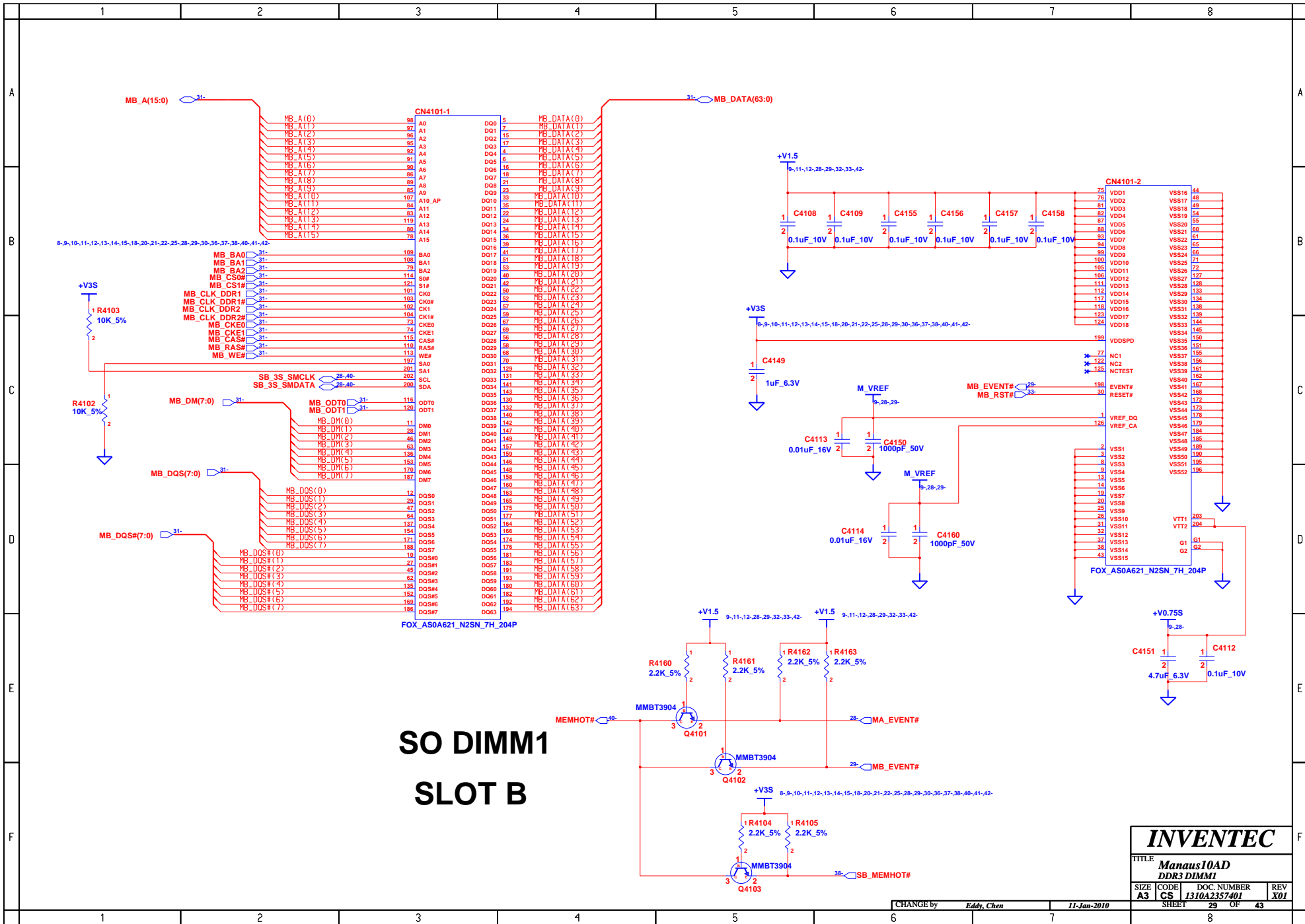

INVENTEC			
TITLE Manaus10AD DDR3 DIMM1			
SIZE A3	CODE CS	DOC NUMBER 1310A2357401	REV X01
CHANGE by <i>Eddy, Chen</i>		11-Jan-2010	
SHEET 29		OF 43	

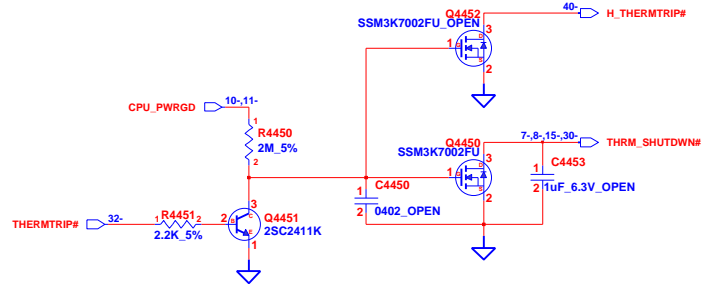

CPU Thermal Sensor

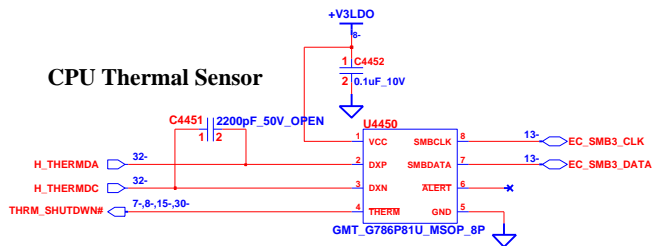

NB Thermal Sensor

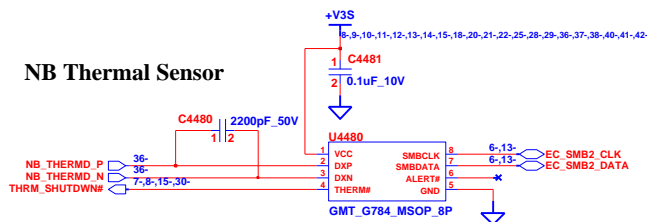

CN4500-1						
L0_CLKIN1	34-	J6	L0_CLKIN_H1	Y4	34-	L0_CLKOUT1
L0_CLKIN1#	34-	K5	L0_CLKIN_L1	Y3	34-	L0_CLKOUT1#
L0_CLKIN0	34-	J3	L0_CLKIN_H0	Y1	34-	L0_CLKOUT0
L0_CLKIN0#	34-	J2	L0_CLKIN_L0	Y1	34-	L0_CLKOUT0#
L0_CTLIN1	34-	P3	L0_CTLIN_H1	T5	34-	L0_CTLOUT1
L0_CTLIN1#	34-	P4	L0_CTLIN_L1	R5	34-	L0_CTLOUT1#
L0_CTLIN0	34-	M1	L0_CTLIN_H0	R2	34-	L0_CTLOUT0
L0_CTLIN0#	34-	P1	L0_CTLIN_L0	R3	34-	L0_CTLOUT0#
L0_CADIN15	34-	N6	L0_CADIN_H15	T4	34-	L0_CADOUT15
L0_CADIN15#	34-	P2	L0_CADIN_L15	T3	34-	L0_CADOUT15#
L0_CADIN14	34-	M3	L0_CADIN_H14	V5	34-	L0_CADOUT14
L0_CADIN14#	34-	M4	L0_CADIN_L14	U5	34-	L0_CADOUT14#
L0_CADIN13	34-	L5	L0_CADIN_H13	V4	34-	L0_CADOUT13
L0_CADIN13#	34-	M6	L0_CADIN_L13	V4	34-	L0_CADOUT13#
L0_CADIN12	34-	K3	L0_CADIN_H12	V5	34-	L0_CADOUT12
L0_CADIN12#	34-	K4	L0_CADIN_L12	W5	34-	L0_CADOUT12#
L0_CADIN11	34-	H3	L0_CADIN_H11	AB5	34-	L0_CADOUT11
L0_CADIN11#	34-	H4	L0_CADIN_L11	AA5	34-	L0_CADOUT11#
L0_CADIN10	34-	G5	L0_CADIN_H10	AB4	34-	L0_CADOUT10
L0_CADIN10#	34-	H5	L0_CADIN_L10	AB3	34-	L0_CADOUT10#
L0_CADIN9	34-	F3	L0_CADIN_H9	AD5	34-	L0_CADOUT9
L0_CADIN9#	34-	F4	L0_CADIN_L9	AC5	34-	L0_CADOUT9#
L0_CADIN8	34-	E5	L0_CADIN_H8	AD4	34-	L0_CADOUT8
L0_CADIN8#	34-	F5	L0_CADIN_L8	AD3	34-	L0_CADOUT8#
L0_CADIN7	34-	N3	L0_CADIN_H7	T1	34-	L0_CADOUT7
L0_CADIN7#	34-	N2	L0_CADIN_L7	R1	34-	L0_CADOUT7#
L0_CADIN6	34-	L1	L0_CADIN_H6	U2	34-	L0_CADOUT6
L0_CADIN6#	34-	M1	L0_CADIN_L6	U2	34-	L0_CADOUT6#
L0_CADIN5	34-	L3	L0_CADIN_H5	V1	34-	L0_CADOUT5
L0_CADIN5#	34-	L2	L0_CADIN_L5	W1	34-	L0_CADOUT5#
L0_CADIN4	34-	J1	L0_CADIN_H4	W2	34-	L0_CADOUT4
L0_CADIN4#	34-	K1	L0_CADIN_L4	W3	34-	L0_CADOUT4#
L0_CADIN3	34-	G1	L0_CADIN_H3	AA2	34-	L0_CADOUT3
L0_CADIN3#	34-	H1	L0_CADIN_L3	AA3	34-	L0_CADOUT3#
L0_CADIN2	34-	G3	L0_CADIN_H2	AB1	34-	L0_CADOUT2
L0_CADIN2#	34-	G2	L0_CADIN_L2	AA1	34-	L0_CADOUT2#
L0_CADIN1	34-	E1	L0_CADIN_H1	AC2	34-	L0_CADOUT1
L0_CADIN1#	34-	F1	L0_CADIN_L1	AC3	34-	L0_CADOUT1#
L0_CADIN0	34-	E3	L0_CADIN_H0	AD1	34-	L0_CADOUT0
L0_CADIN0#	34-	E2	L0_CADIN_L0	AC1	34-	L0_CADOUT0#

Layout: Add stitching caps if crossing plane split.

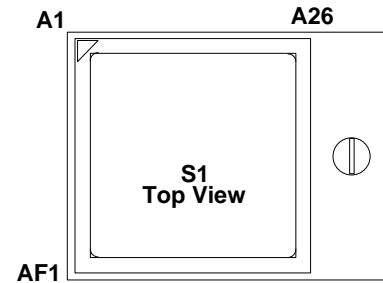

INVENTEC

TITLE
Manaus10AD
CPU-1

SIZE	CODE	DOC. NUMBER	REV
A3	CS	1310A2337401	X01

CHANGE by *Eddy, Chen* 11-Jan-2010

SHEET	30	OF	43
-------	----	----	----

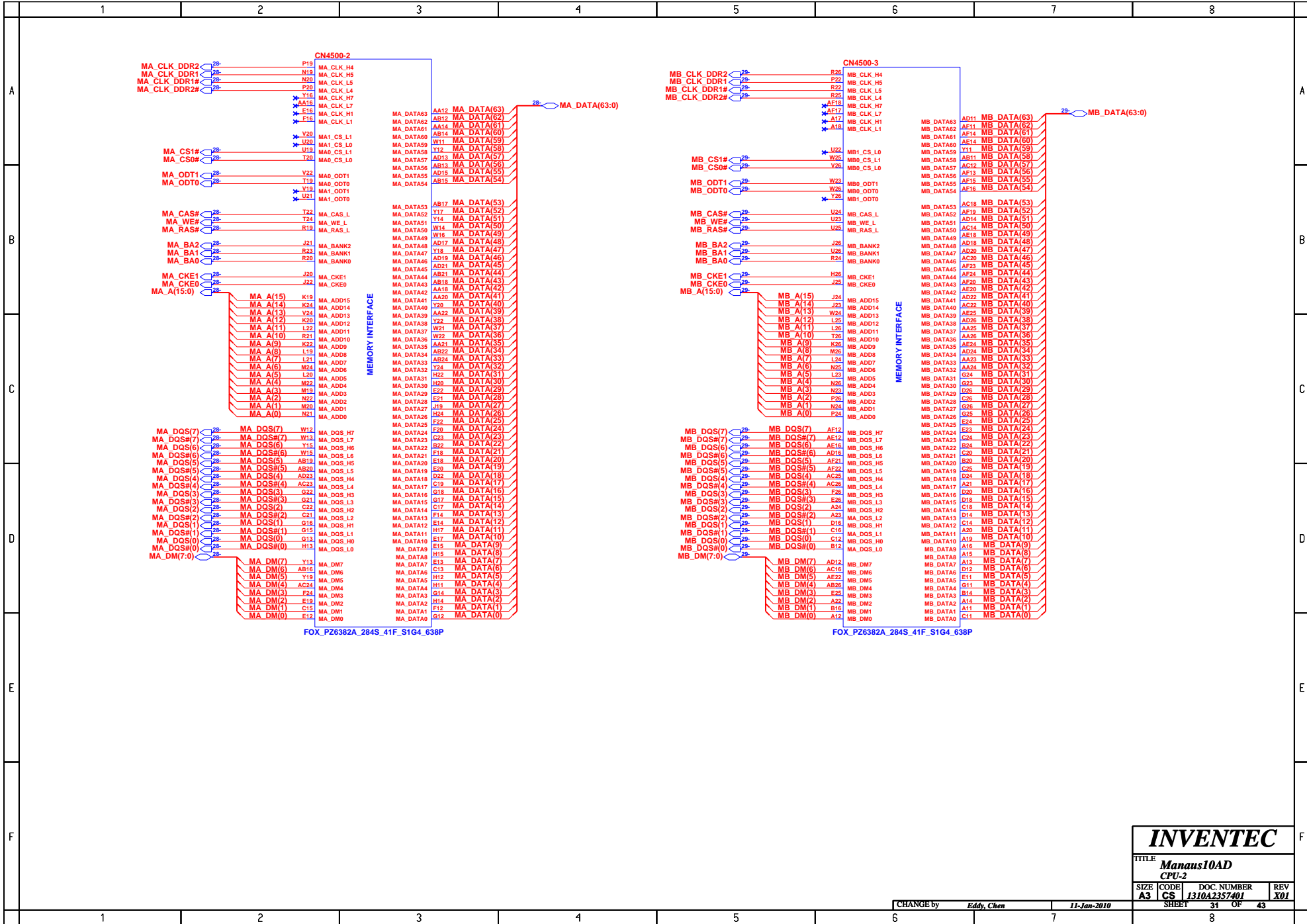

INVENTEC			
TITLE Manaus10AD			
CPU-2			
SIZE	CODE	DOC. NUMBER	REV
A3	CS	1310A2337401	X01
CHANGE by		Eddy, Chen	11-Jan-2010
SHEET		31	OF 43

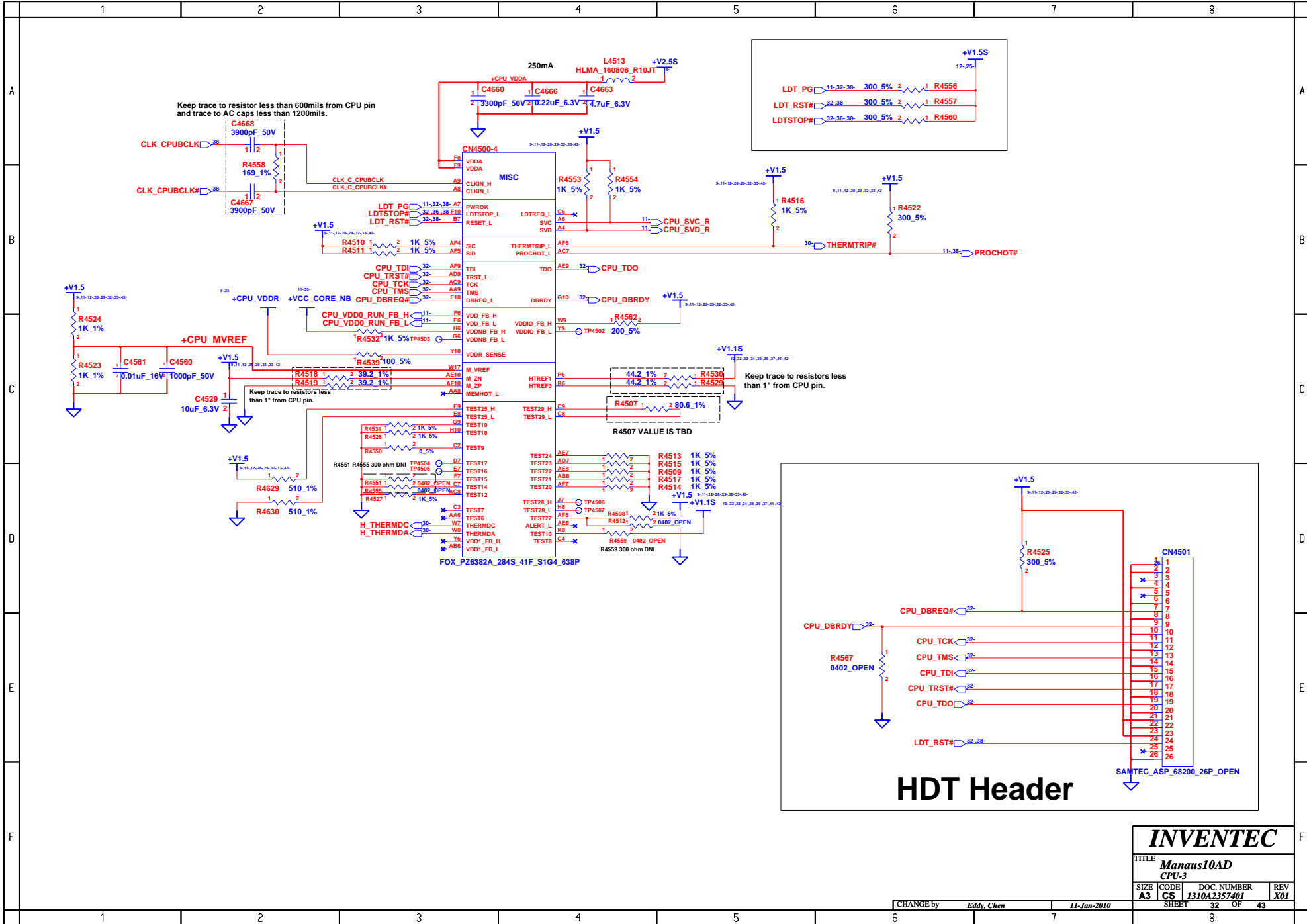

HDT Header

INVENTEC

TITLE
Manaus10AD
CPU-3

SIZE	CODE	DOC. NUMBER	REV
A3	CS	1310A2337401	X01

CHANGE by *Eddy, Chen* 11-Jan-2010 SHEET 32 OF 43

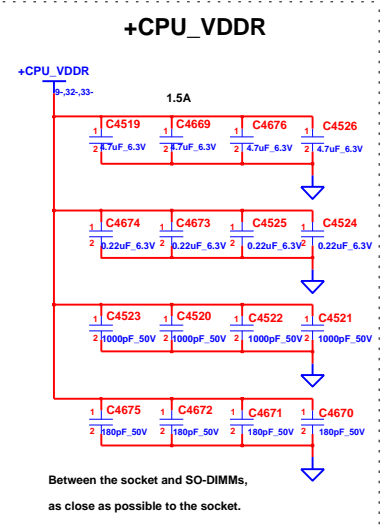
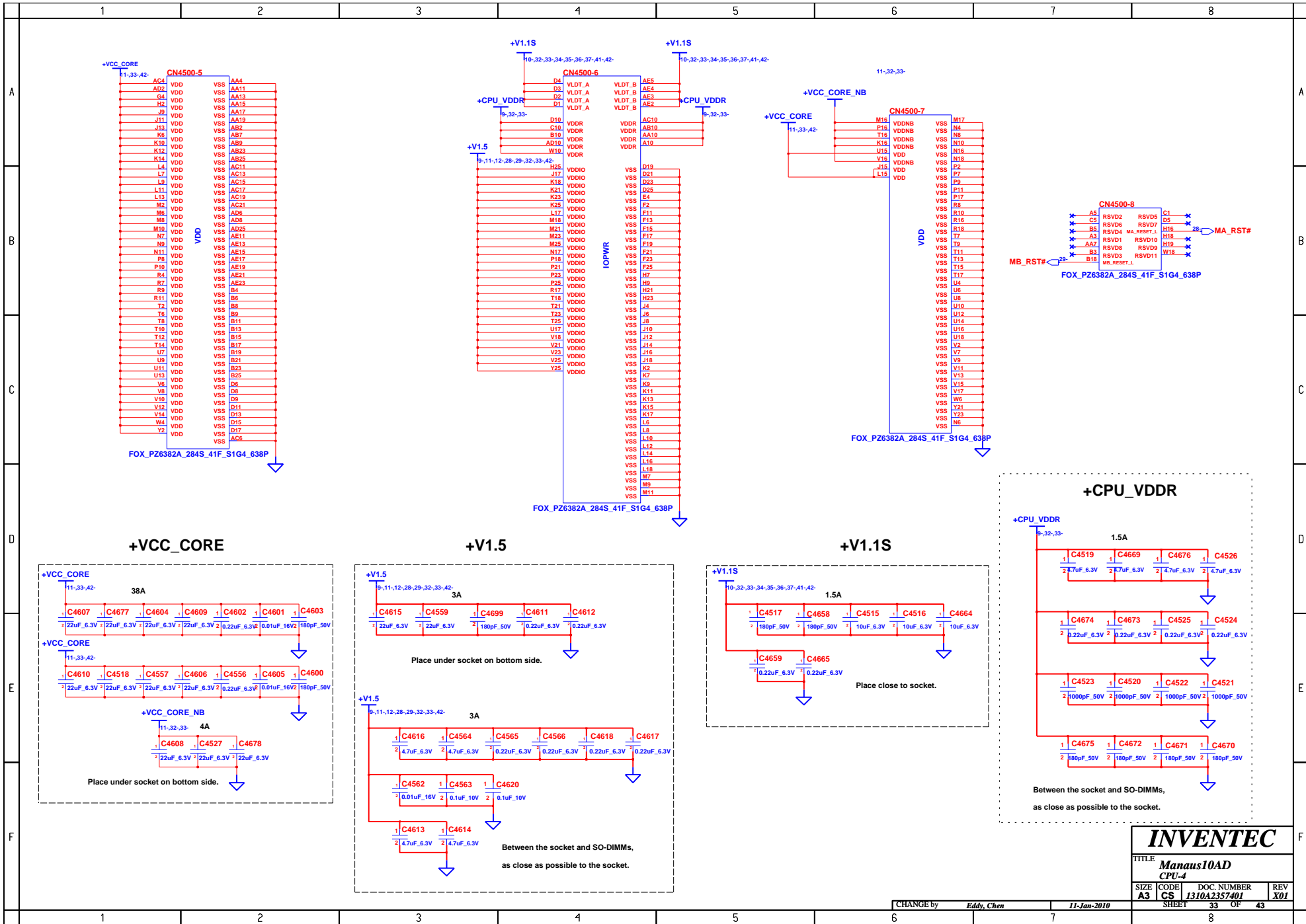

INVENTEC			
TITLE Manaus10AD CPU-4			
SIZE A3	CODE CS	DOC. NUMBER 1310A2357401	REV X01
CHANGE by <i>Eddy, Chen</i>		11-Jan-2010	
SHEET 33		OF 43	

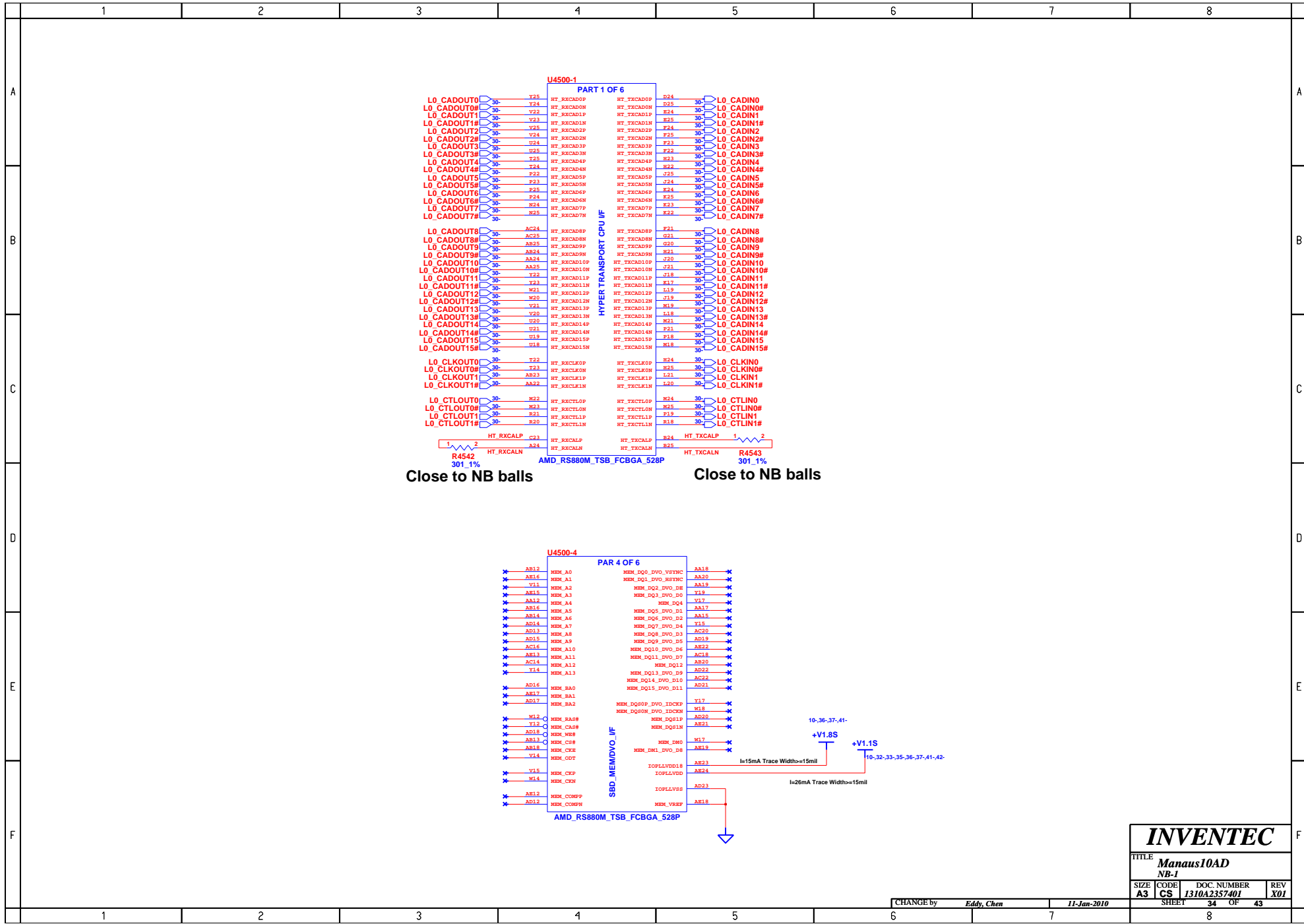

INVENTEC			
TITLE Manaus10AD			
NB-1			
SIZE A3	CODE CS	DOC. NUMBER 1310A2357401	REV X01
CHANGE by <i>Eddy, Chen</i>		11-Jan-2010	
SHEET 34		OF 43	

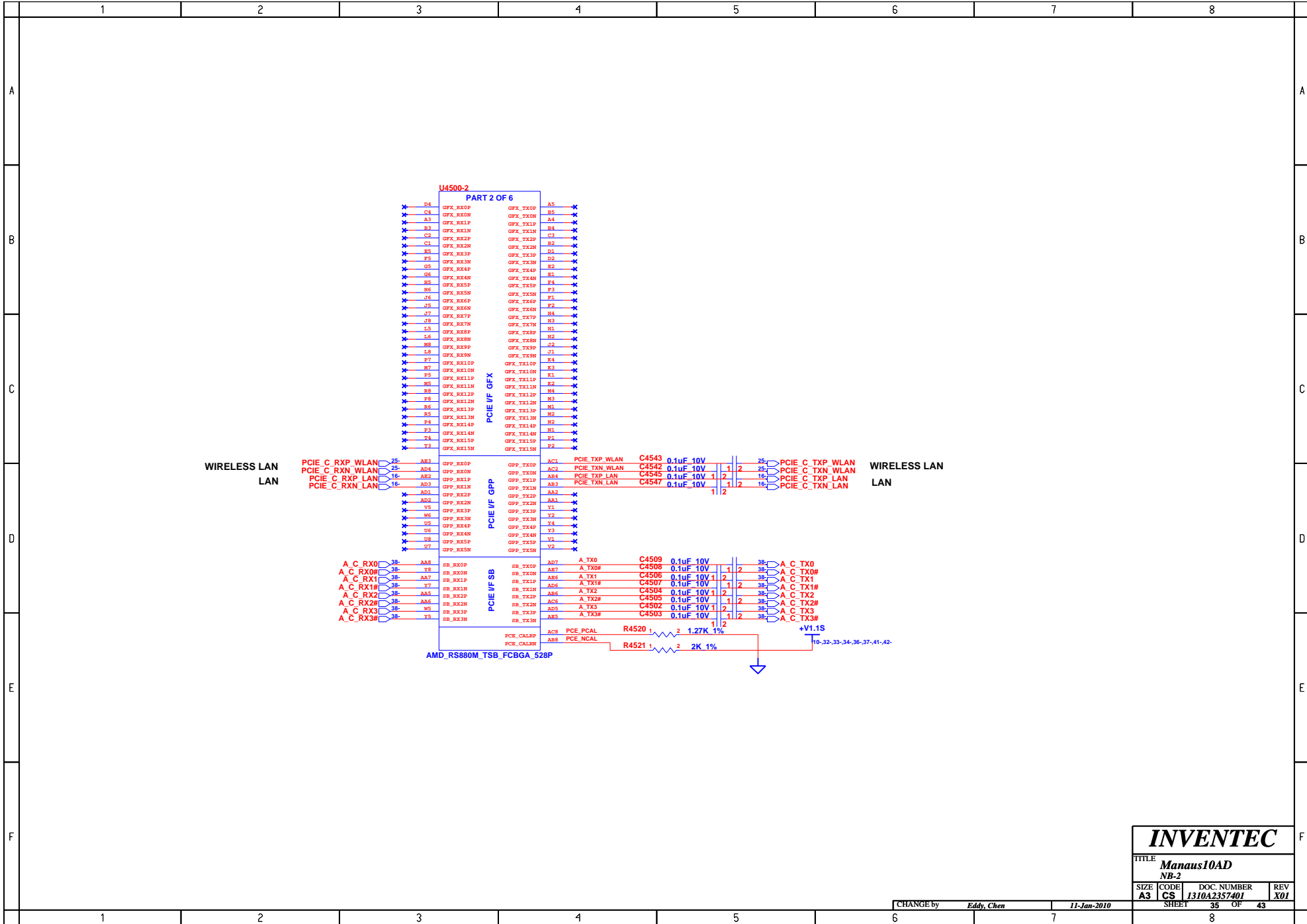

INVENTEC			
TITLE Manaus10AD			
NB-2			
SIZE A3	CODE CS	DOC. NUMBER 1310A2357401	REV X01
CHANGE by <i>Eddy, Chen</i>		11-Jan-2010	
SHEET		35	OF 43

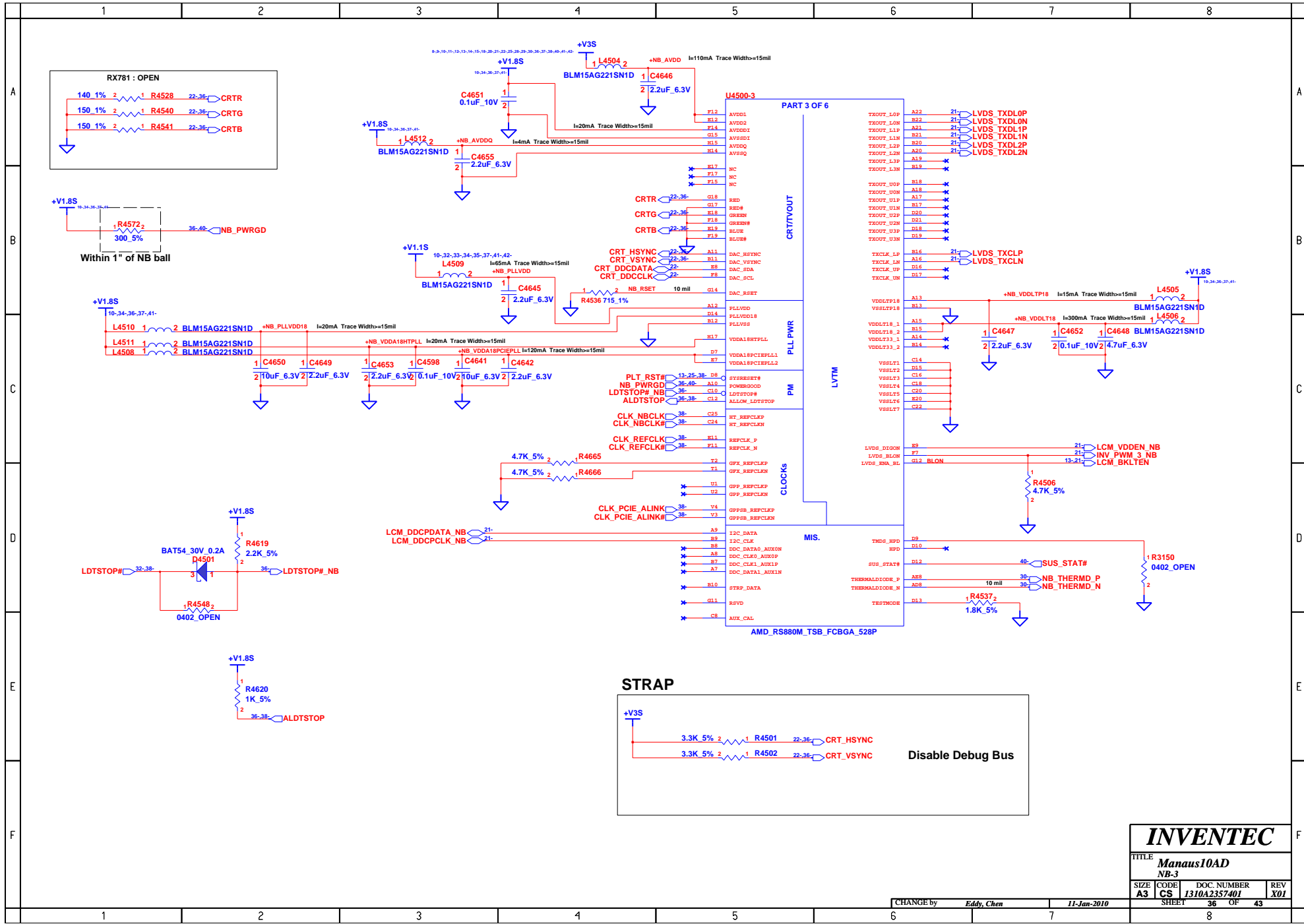

INVENTEC			
TITLE Manaus10AD			
NB-3			
SIZE A3	CODE CS	DOC. NUMBER 1310A2357401	REV X01
CHANGE by <i>Eddy, Chen</i>		11-Jan-2010	
SHEET 36		OF 43	

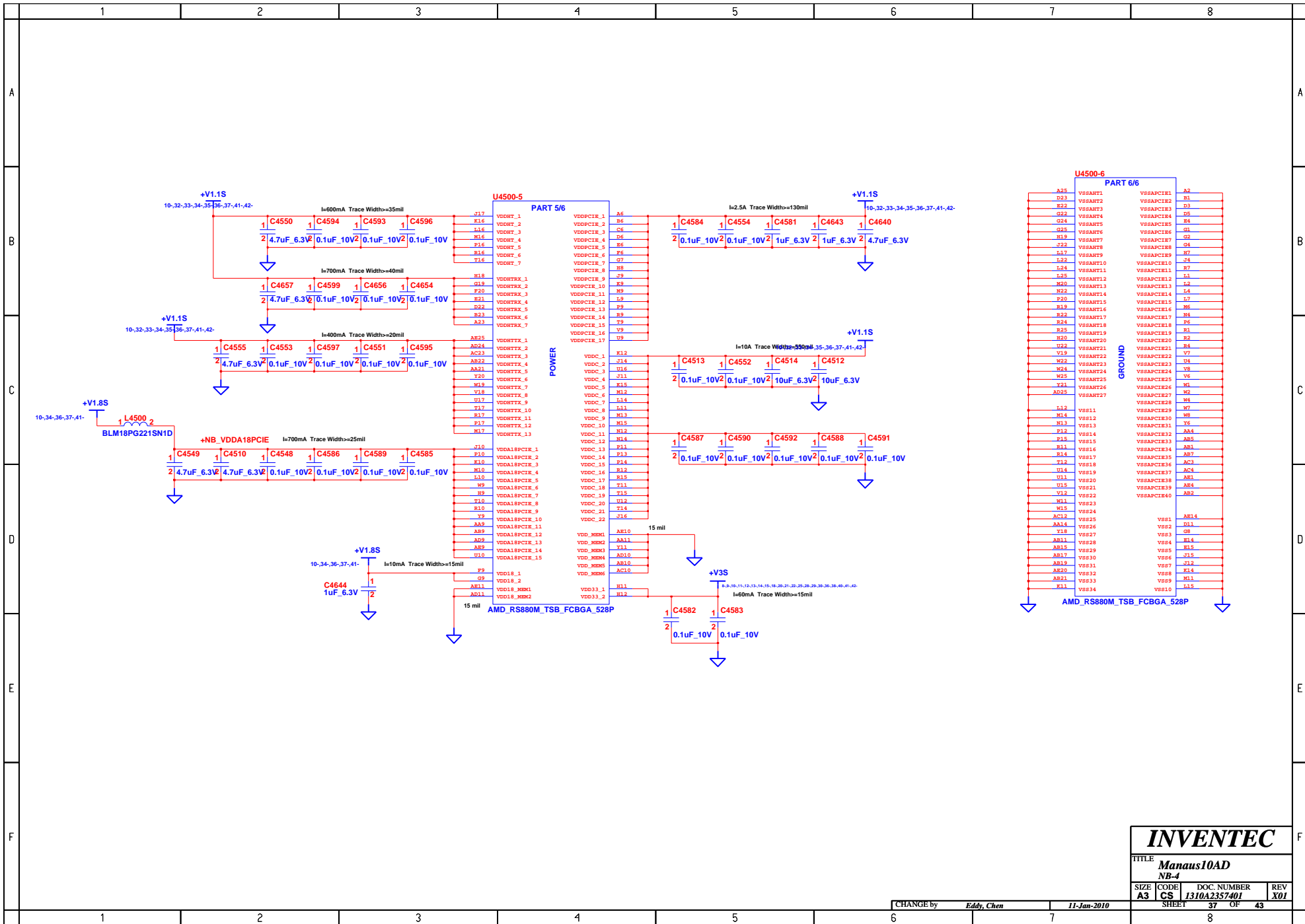

INVENTEC

TITLE **Manaus10AD**
NB-4

SIZE	CODE	DOC. NUMBER	REV
A3	CS	1310A2337401	X01

CHANGE by *Eddy, Chen* 11-Jan-2010

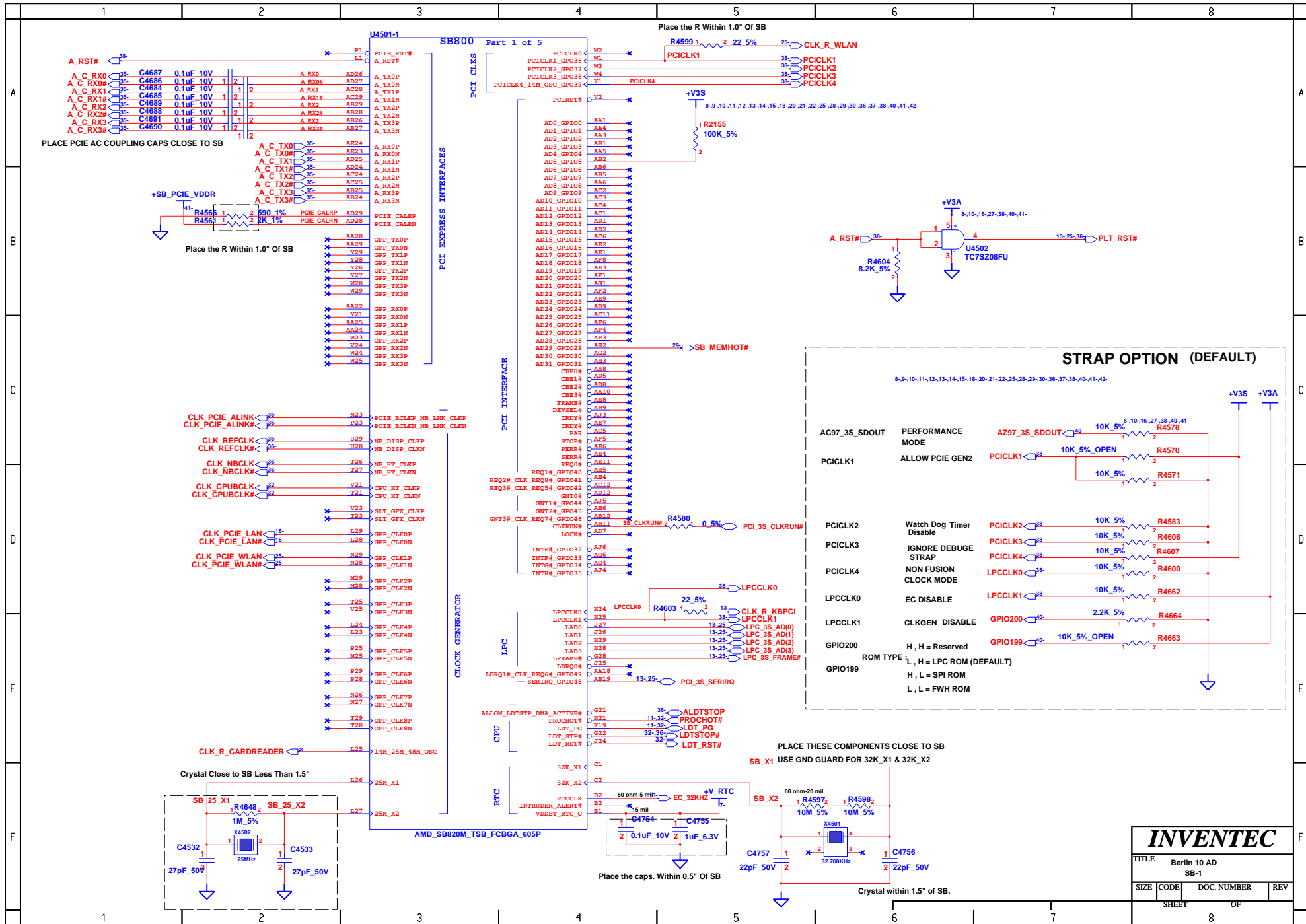

INVENTEC			
TITLE Berlin 10 AD			
SB-1			
SIZE	CODE	DOC. NUMBER	REV
SHEET		OF	
8		8	

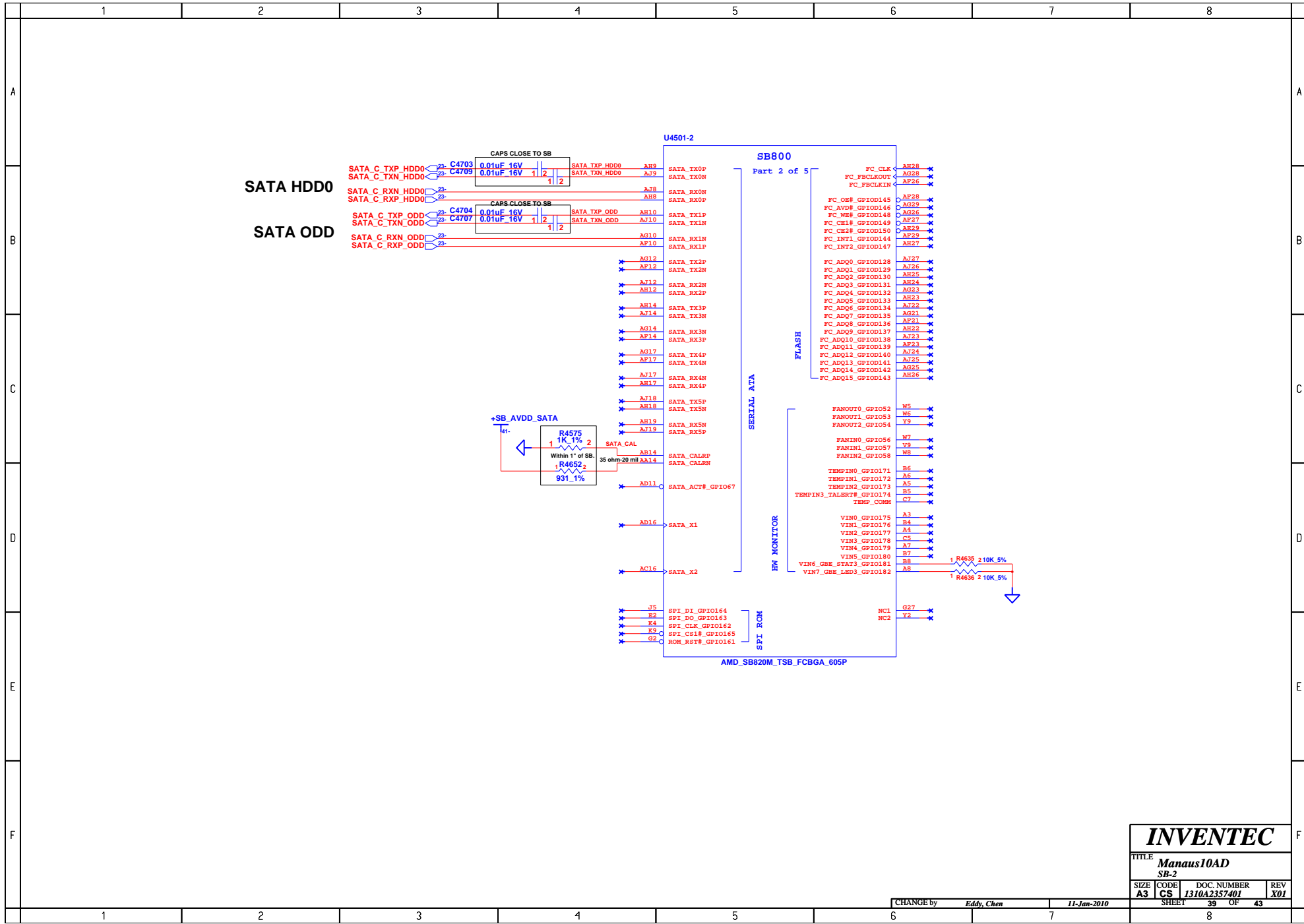

INVENTEC			
TITLE			
Manaus10AD			
SB-2			
SIZE	CODE	DOC. NUMBER	REV
A3	CS	1310A2337401	X01
CHANGE by		11-Jan-2010	
Eddy, Chen		39 OF 43	

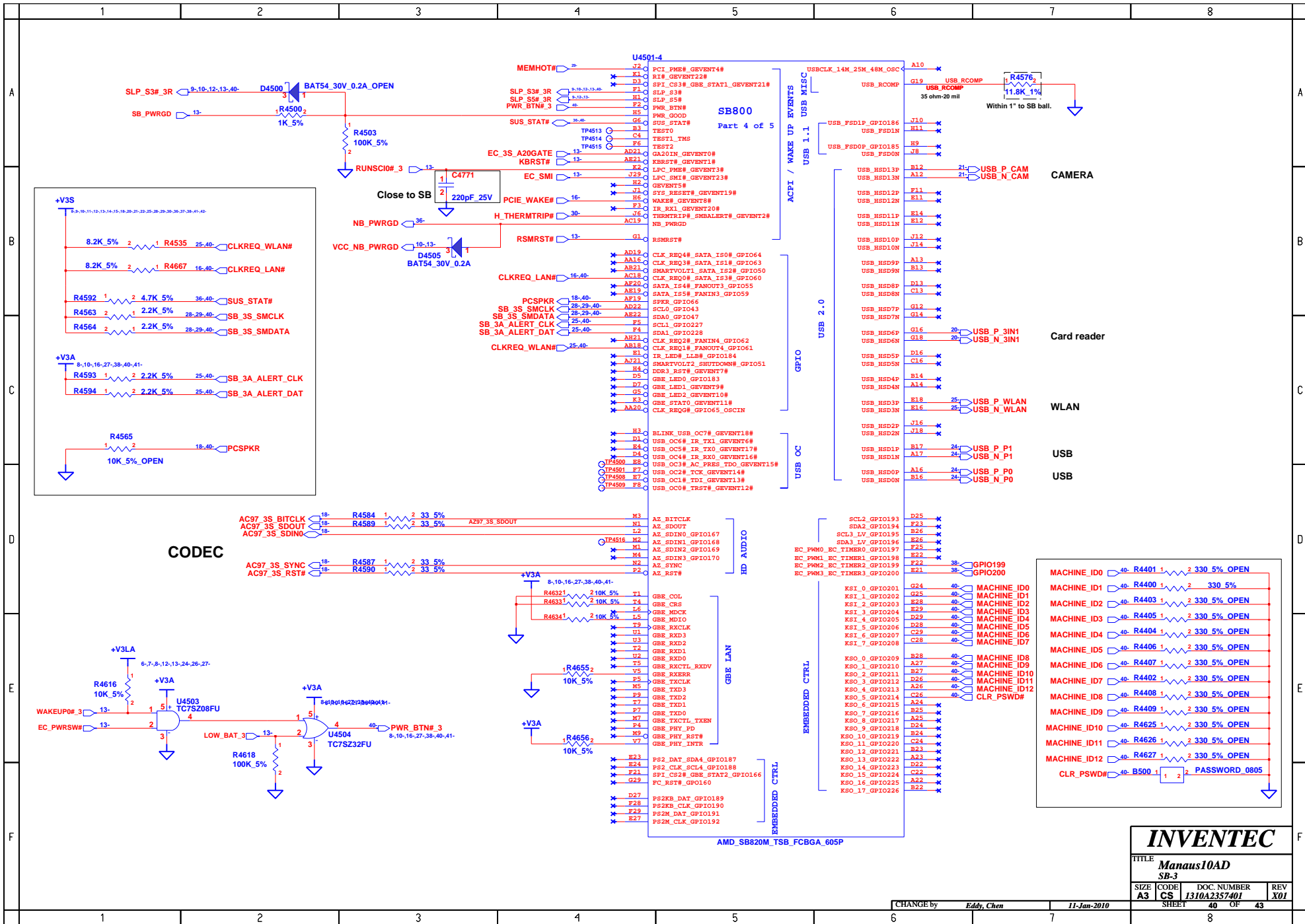

PLACE ALL THE DECOUPLING CAPS ON THIS SHEET CLOSE TO SB AS POSSIBLE

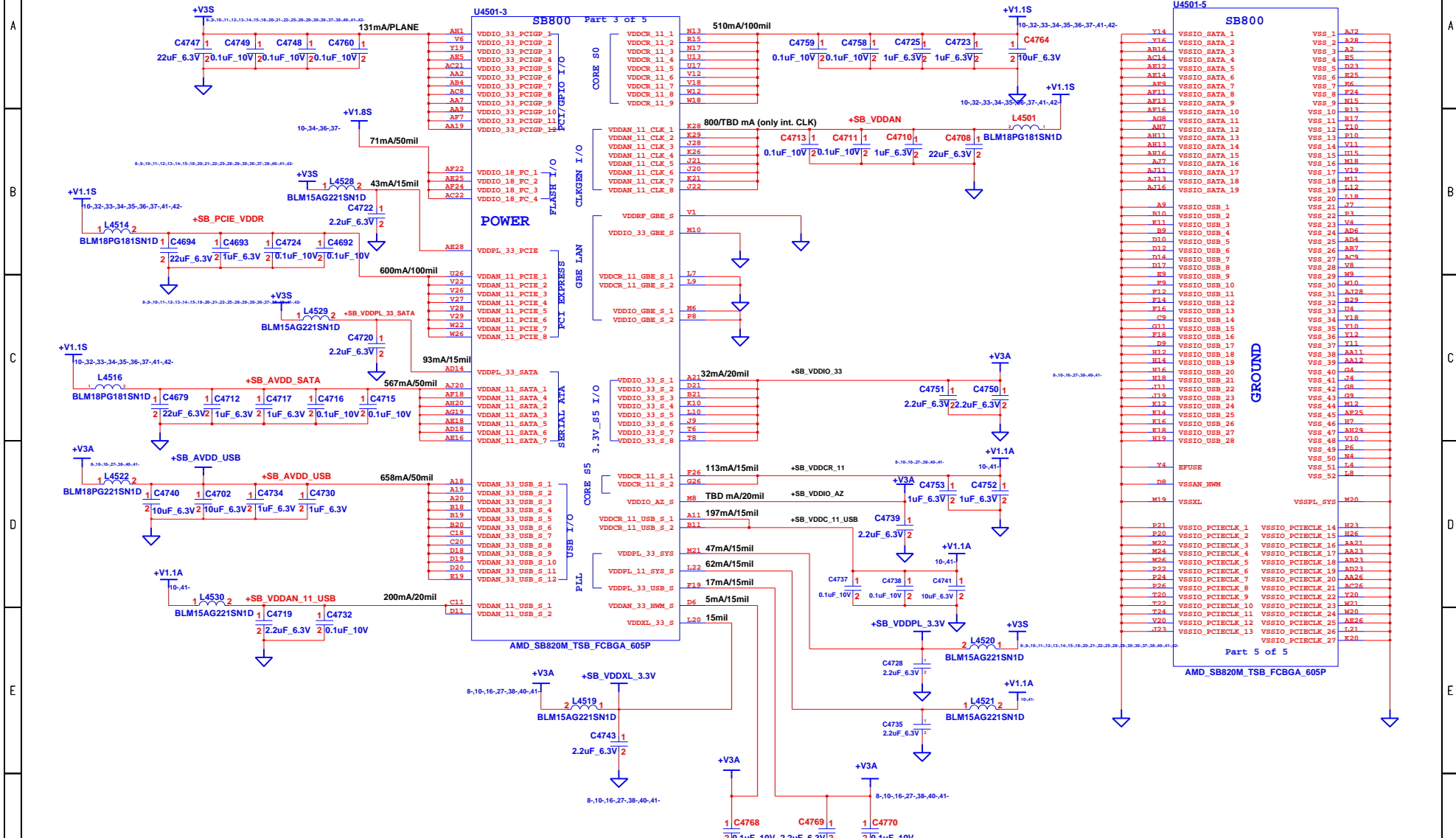

INVENTEC			
TITLE Manaus10AD			
SB-4			
SIZE A3	CODE CS	DOC NUMBER 1310A2357401	REV X01
CHANGE by <i>Eddy, Chen</i>		11-Jan-2010	
SHEET		41 OF 43	

EMI

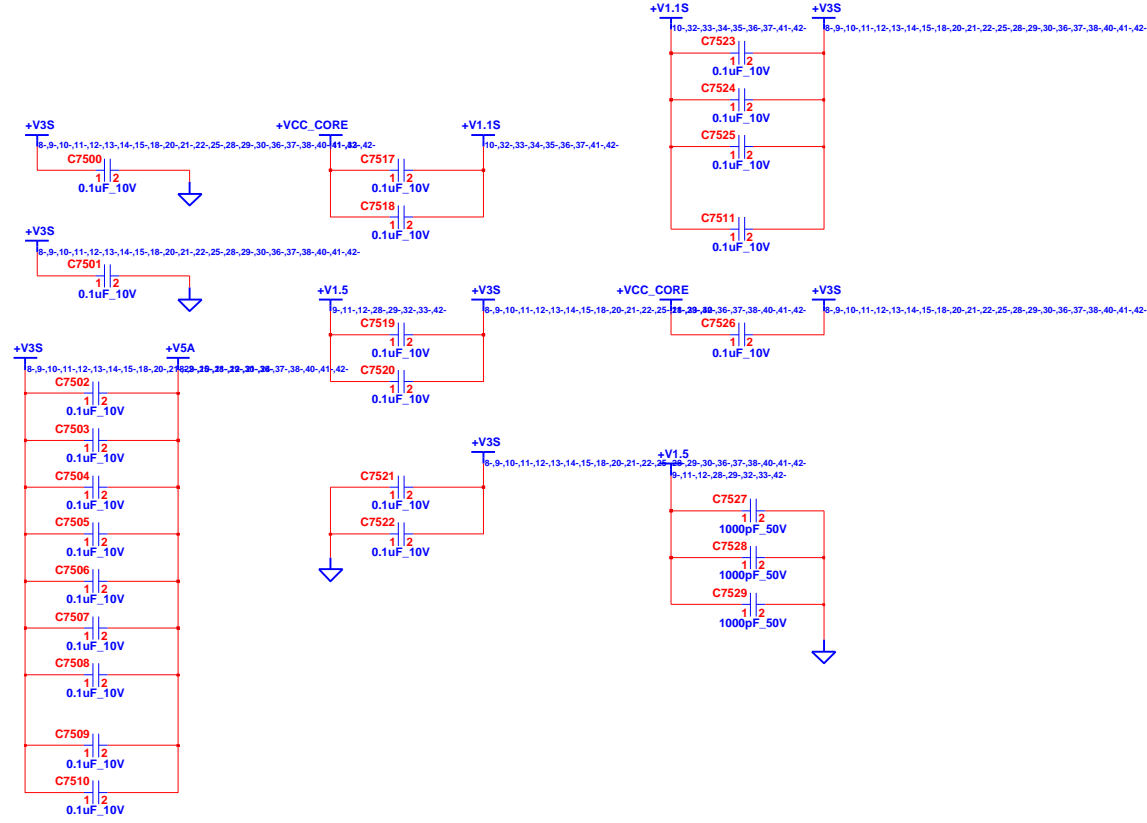

INVENTEC

TITLE			
Manaus10AD			
EMI			
SIZE	CODE	DOC NUMBER	REV
A3	CS	1310A2357401	X01
SHEET		OF	43
8			

CHANGE by Eddy, Chen 11-Jan-2010

POWER BUTTON

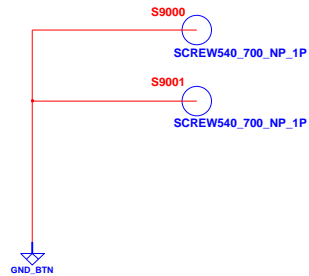
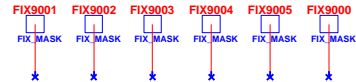
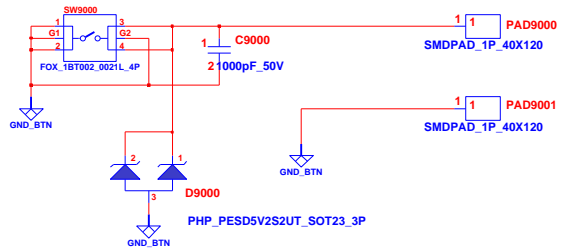

INVENTEC			
TITLE Manaus10AD Pick Button Board			
SIZE A3	CODE CS	DOC. NUMBER 1310A2357401	REV X01
CHANGE by <i>Eddy, Chen</i>		16-Mar-2010	
SHEET		43	OF 43