

STACK LAYERS

L1 : TOP
 L2 : VCC
 L3 : IN1 (Hig Speed)
 L4 : GND
 L5 : IN2 (High Speed)
 L6 : BOT

Power - Source Control

- CPU CORE Power PAGE34.
- 1.25V/ 2.5V DDR Power PAGE31.
- 5V / 3.3V System Power PAGE33.
- AC/BATT CONNECTOR
- BATT CHARGER PAGE 30,32.

KT9D

P/N: DAKT9DMB6A0

Northwood CPU
 (Micro-FCPGA)
 PAGE 2.3.

PCIBUSROUTINGTABLE

1394	--	AD23,-INTC,-REQ3,-GNT3
LAN	--	AD29,-INTB,-REQ2,-GNT2
MINIPCI	--	AD20,-INTC,-INTD,-REQ0,-GNT0
PCI HUB	--	-REQ1,-GNT1
PCMCIA	--	AD21,-INTF,-REQ4,-GNT4
USB 2.0	--	AD22,-INTC,-INTD,-INTF,-REQ5,-GNT5

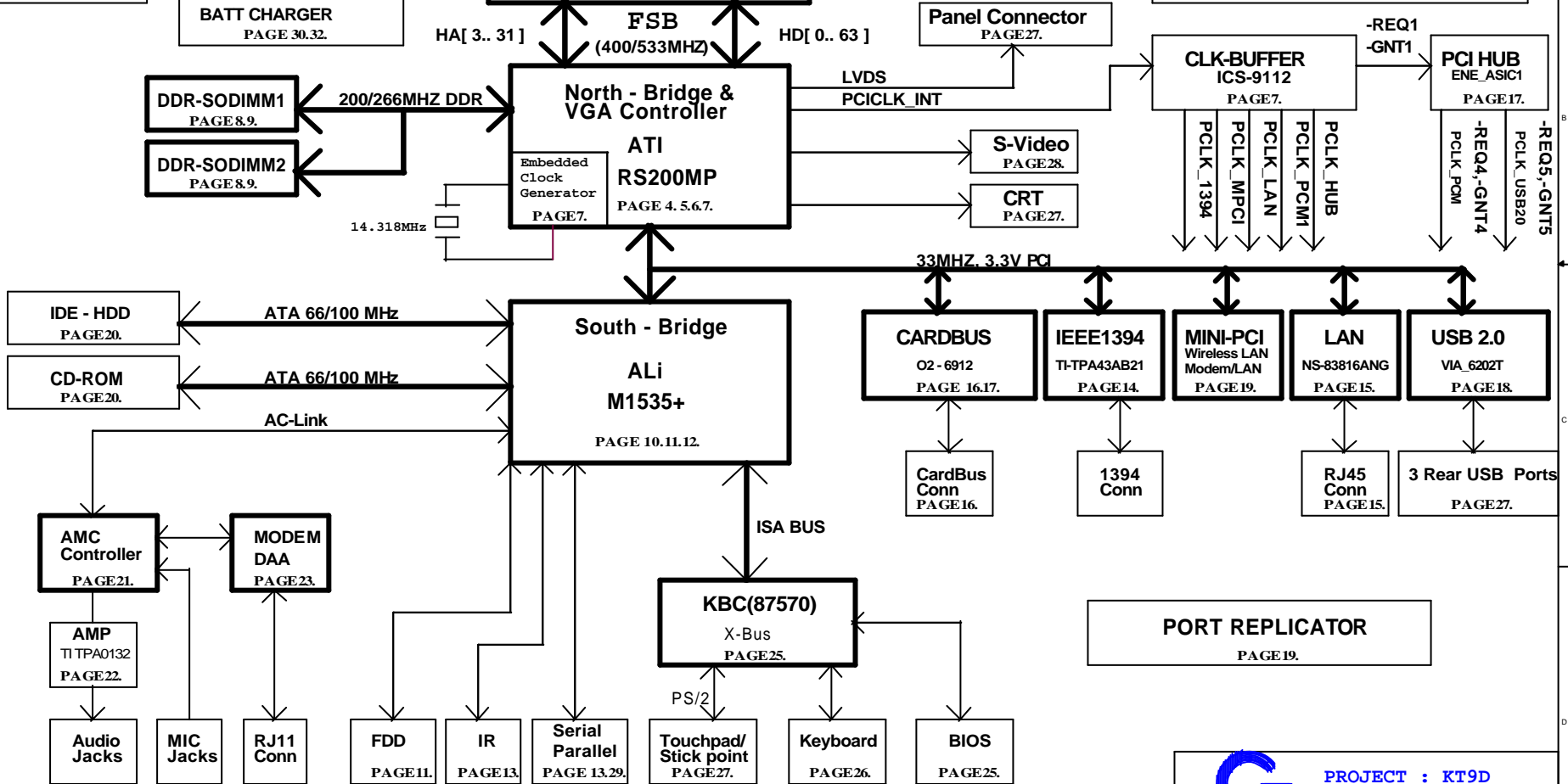

PROJECT : KT9D
Quanta Computer Inc.

Size	Document Number	Rev
	BLOCK DIAGRAM	1A
Date:	Monday, March 17, 2003	Sheet 1 of 35

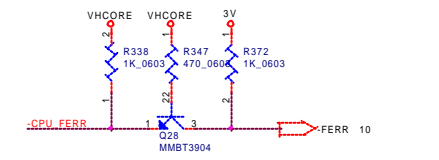
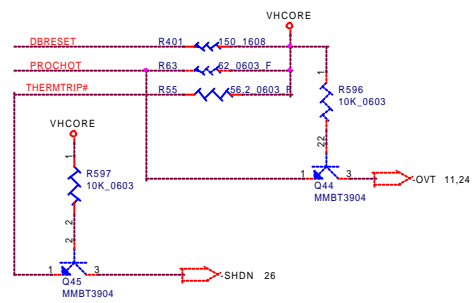
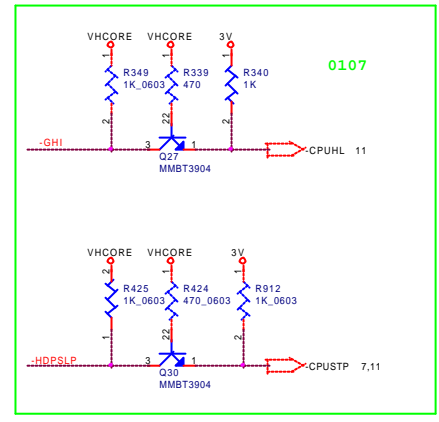
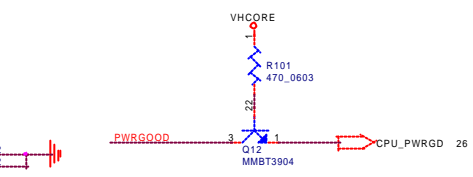
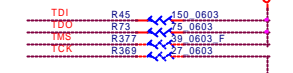
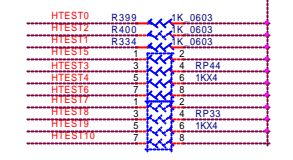
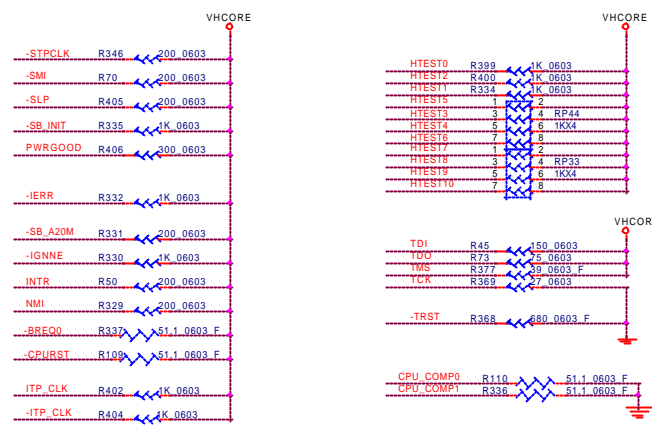
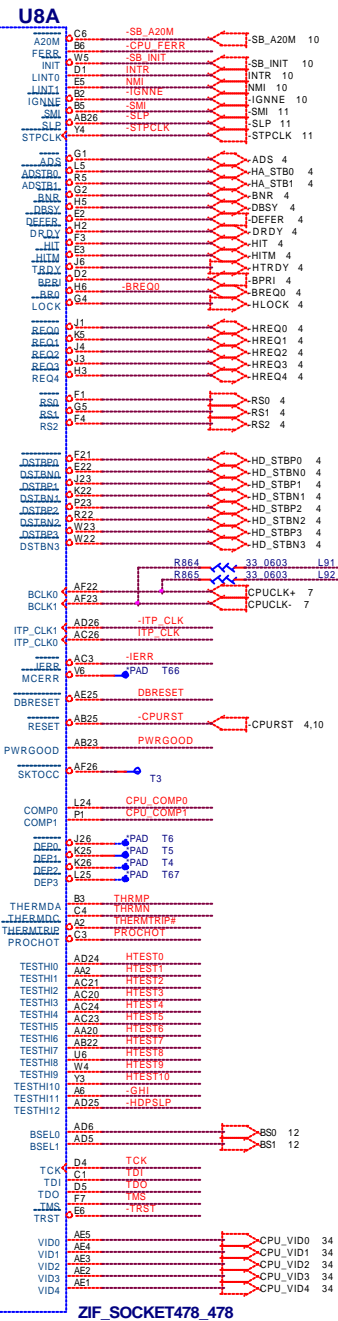

H/W MONITOR

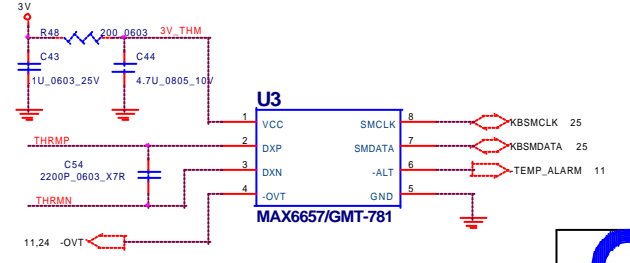

PROJECT : KT9D
Quanta Computer Inc.

Size	Document Number	Rev
	NORTHWOOD CPU -A	1A
Date	Monday, March 17, 2003	Sheet 2 of 35

NORTHWOOD CPU -B

03

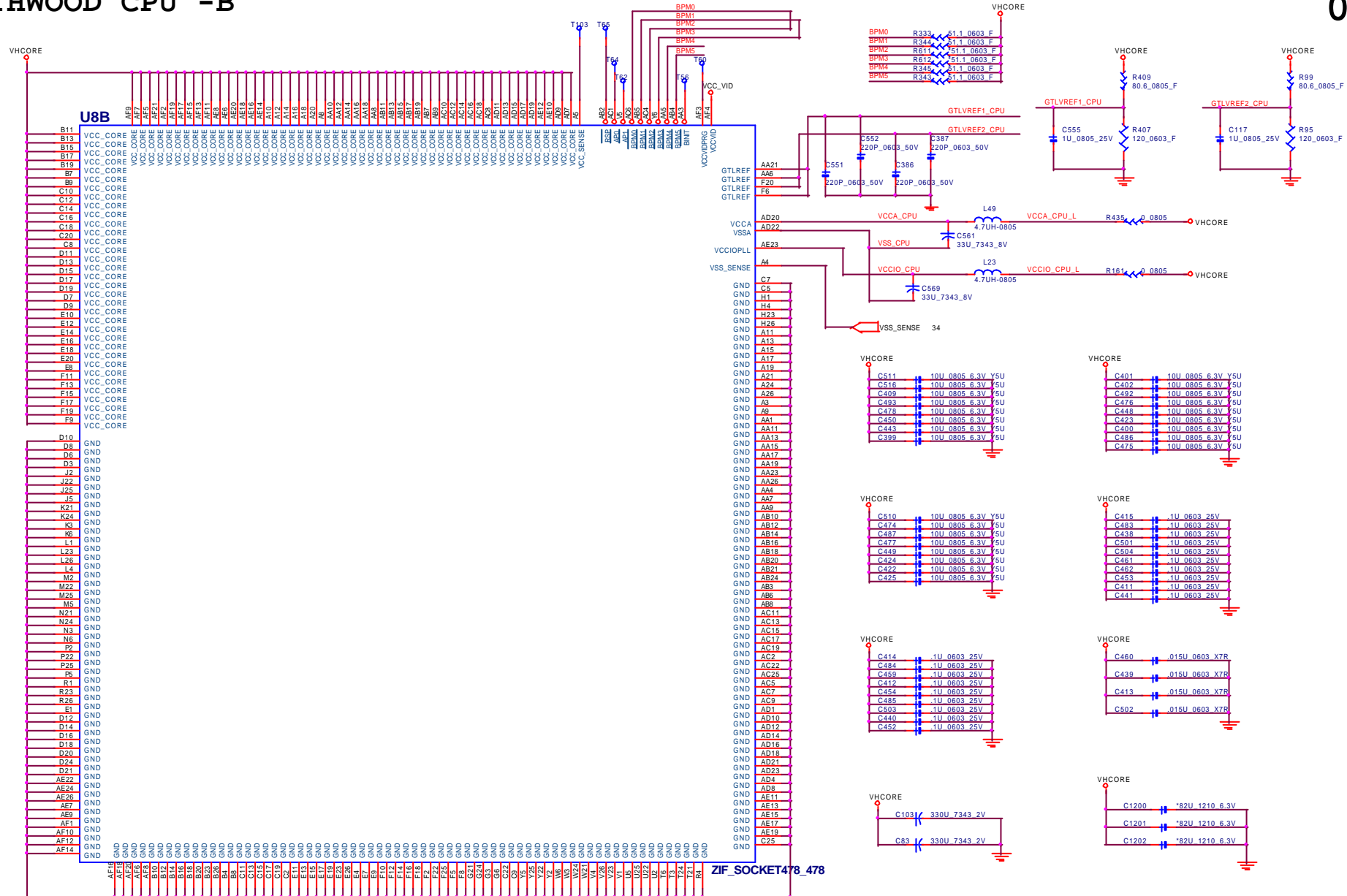

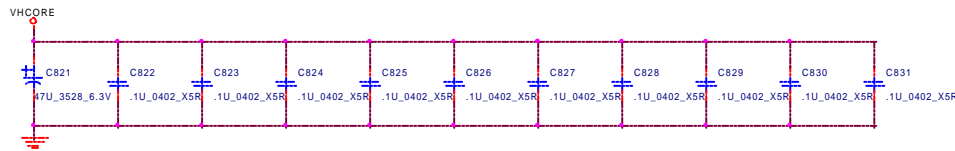
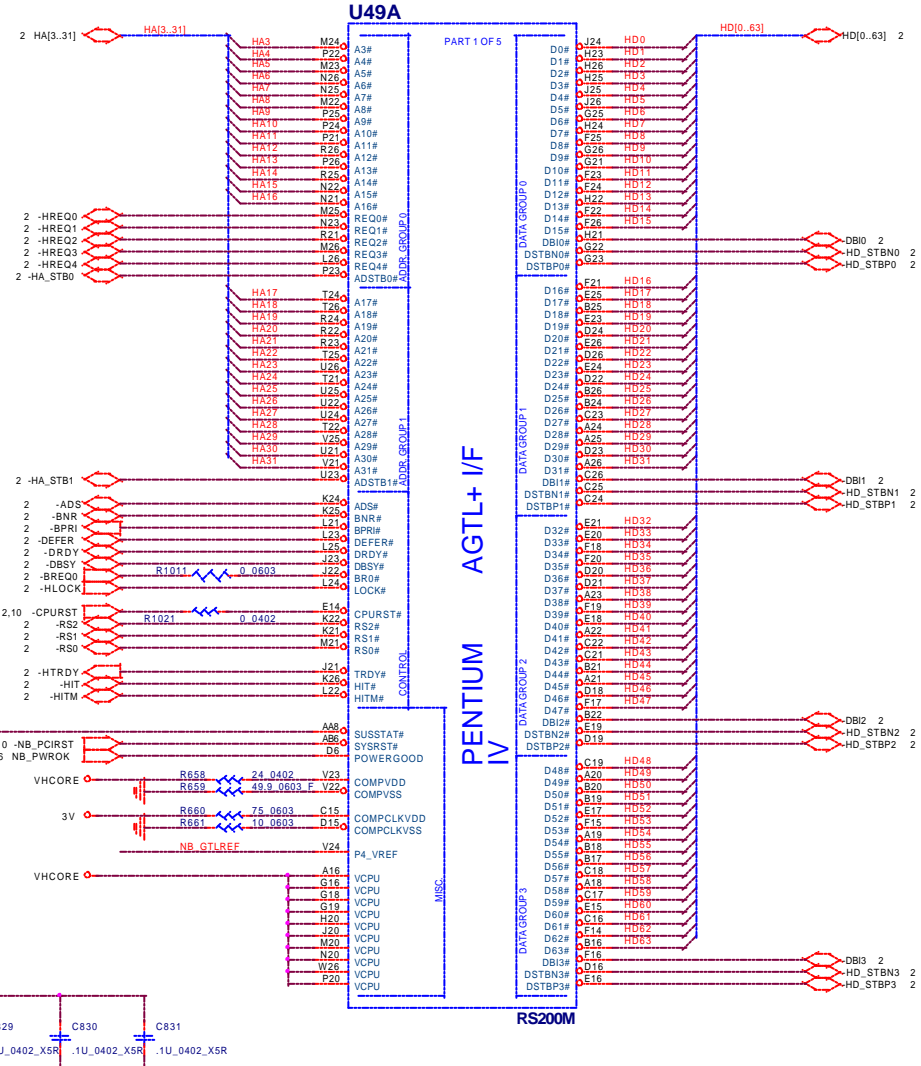
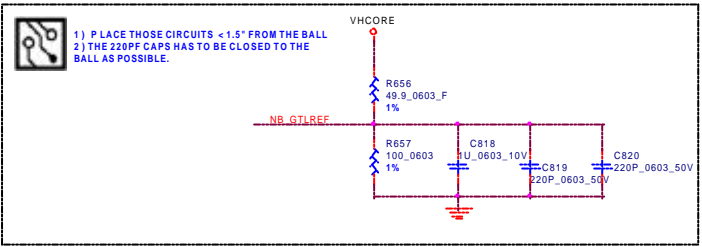

PROJECT : KT9D
Quanta Computer Inc.

Size	Document Number	Rev
	RS200M-(AGTL+)	1A
Date	Monday, March 17, 2003	Sheet 4 of 35

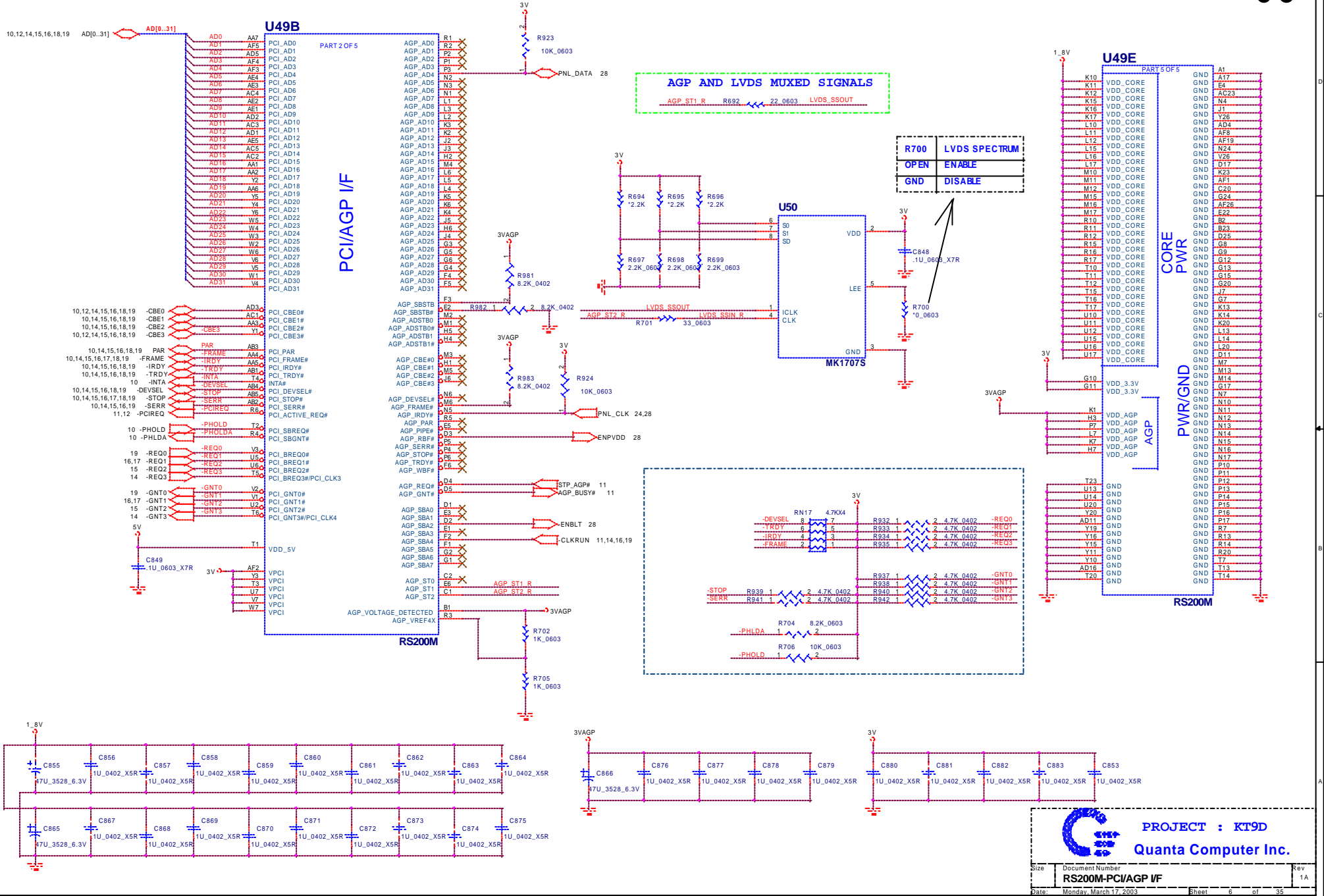

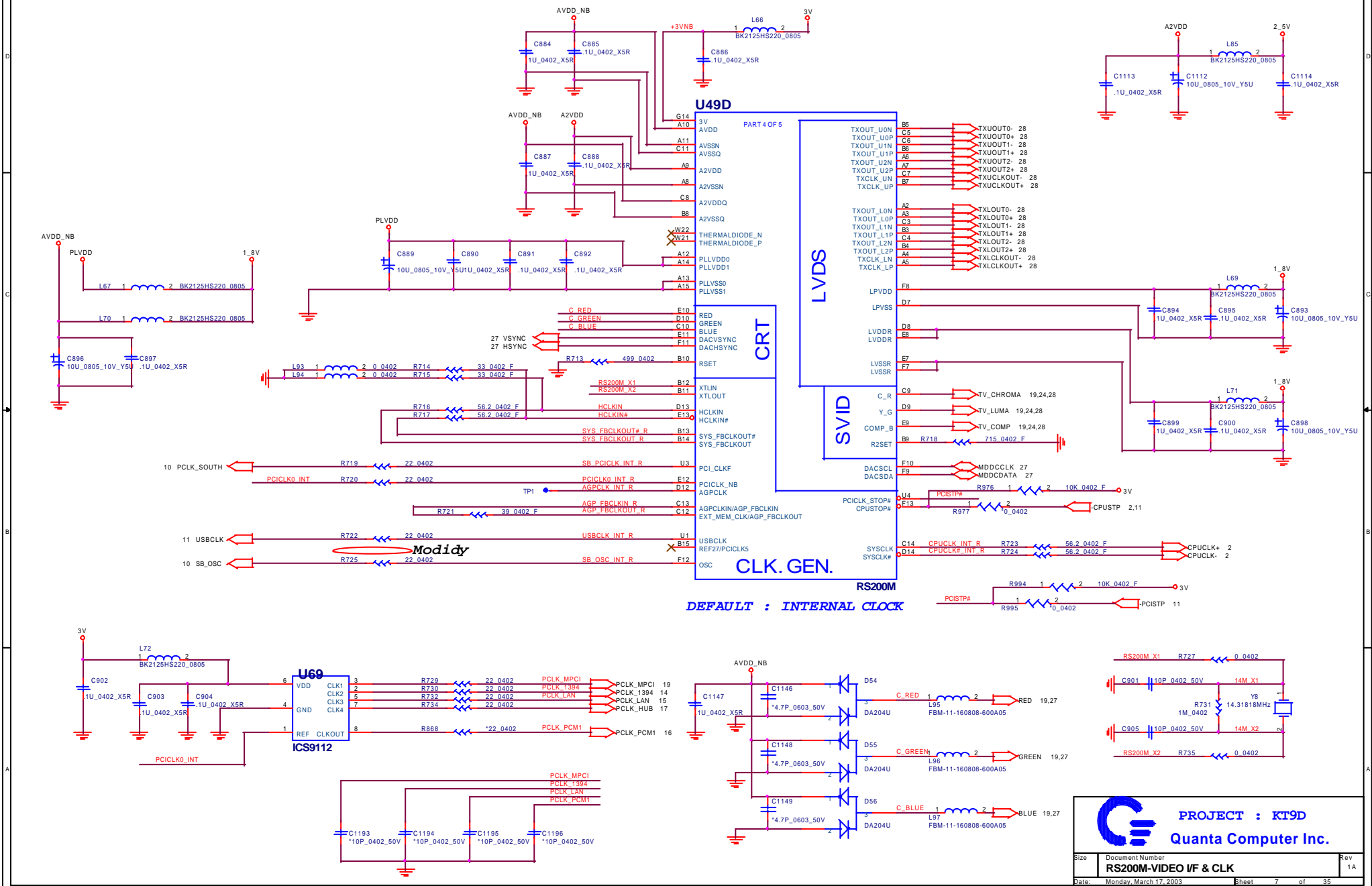

PROJECT : KT9D
Quanta Computer Inc.

Size	Document Number	Rev
	RS200M-VIDEO I/F & CLK	1A
Date	Menday, March 17, 2003	Sheet 7 of 35

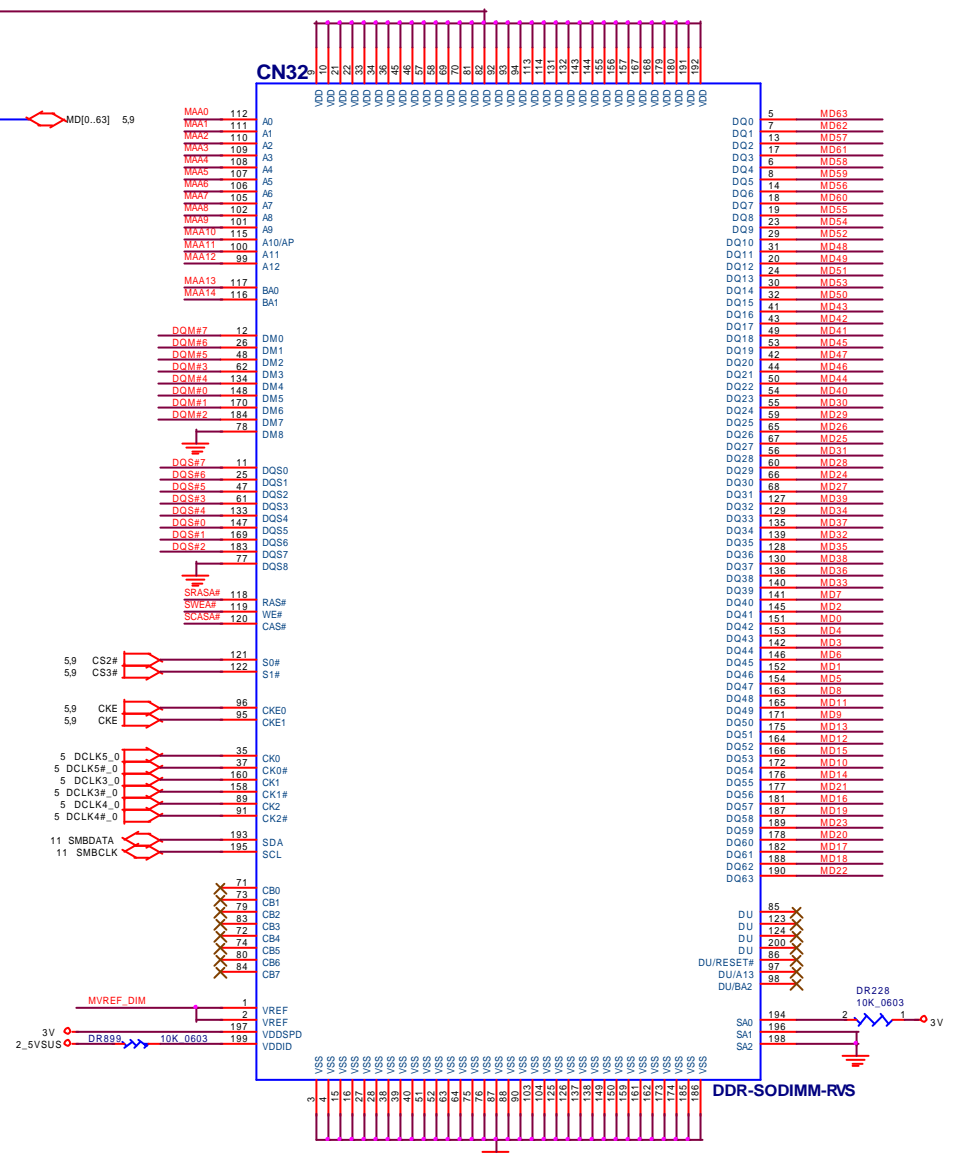
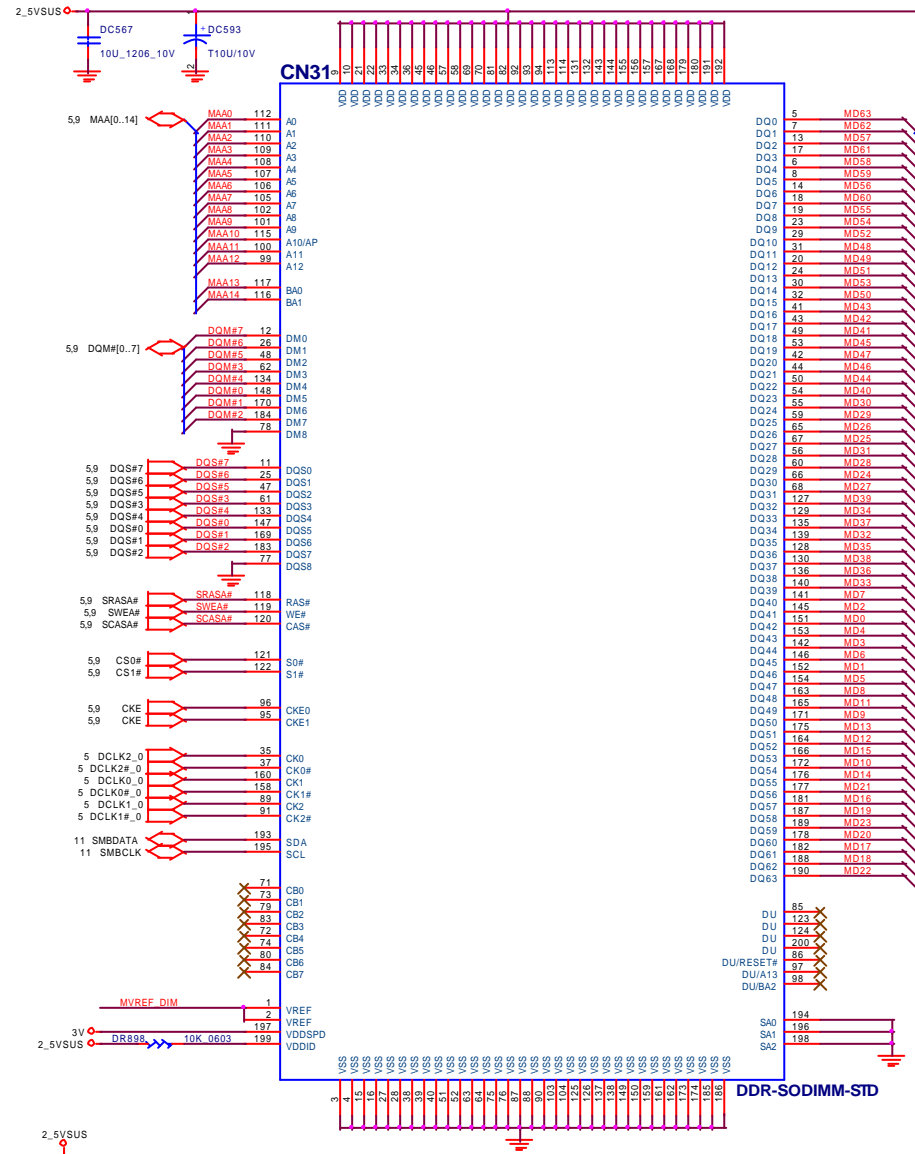

PROJECT : KT9D
Quanta Computer Inc.

Size: Document Number
DDR MODULES

Date: Monday, March 17, 2003 Sheet 8 of 35



MD & DQM & DQS Terminator

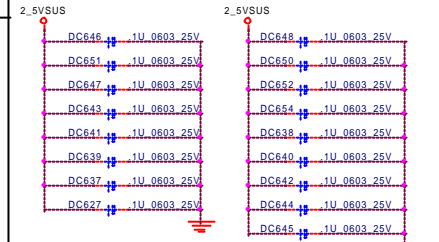
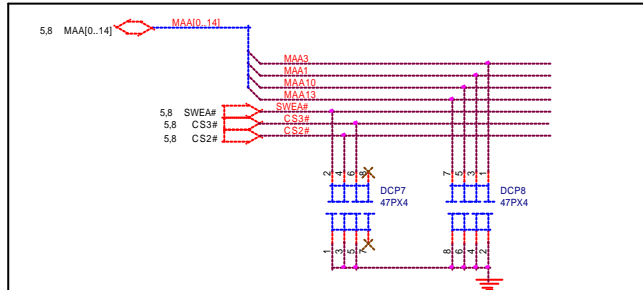
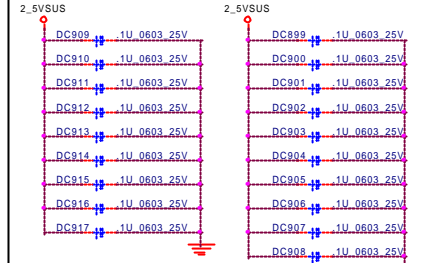
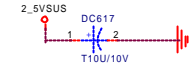
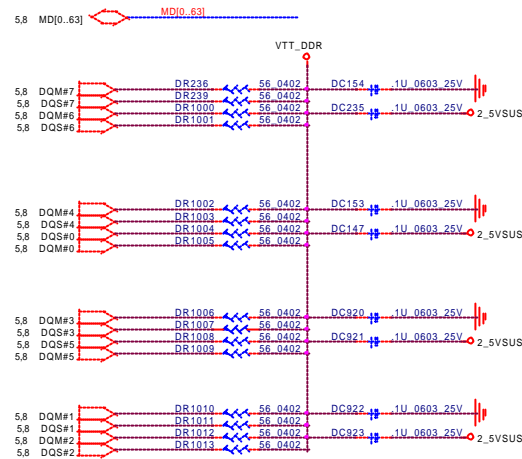
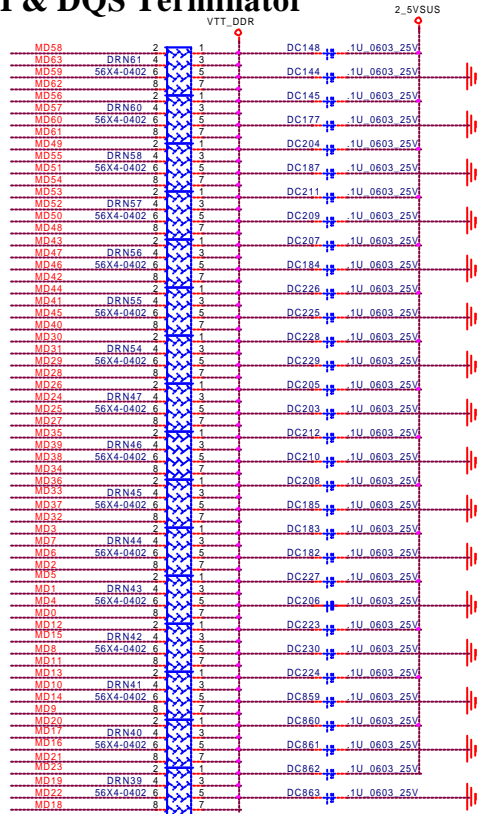

MA Terminator

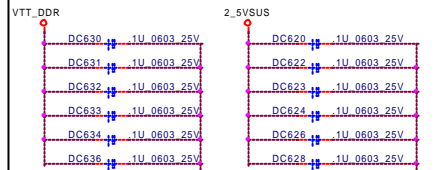
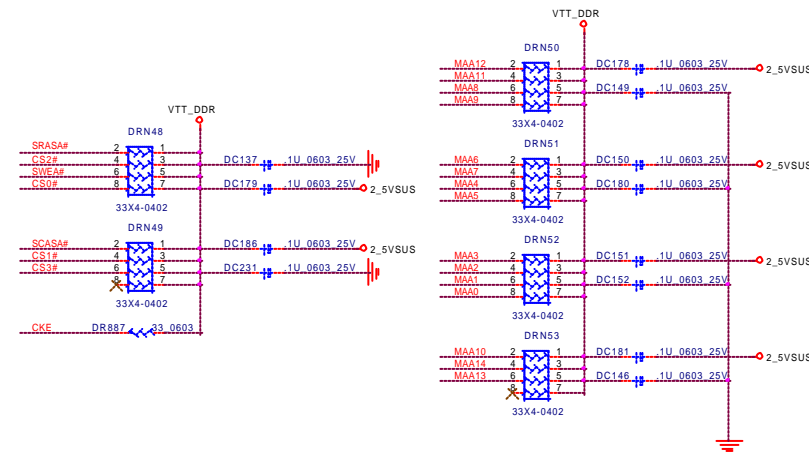
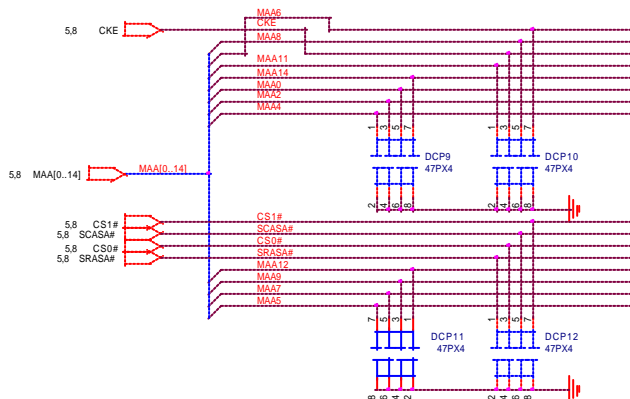

M1535+_USB,IDE,FDD INTERFACE

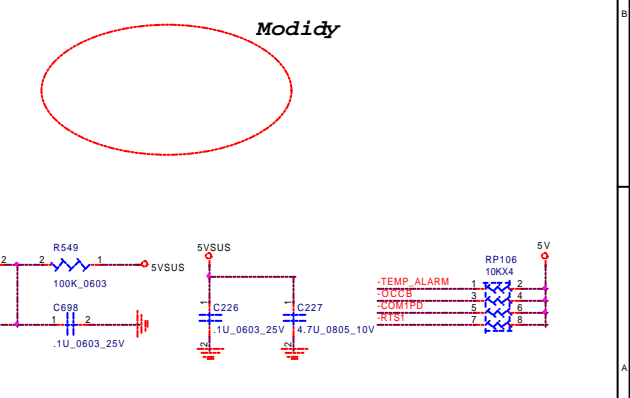
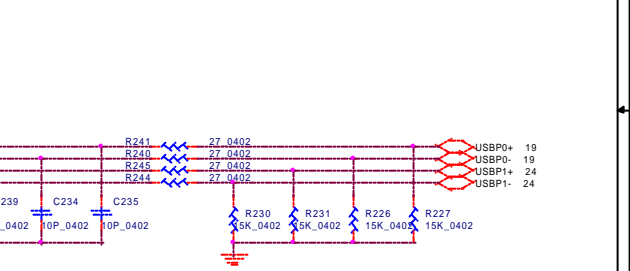
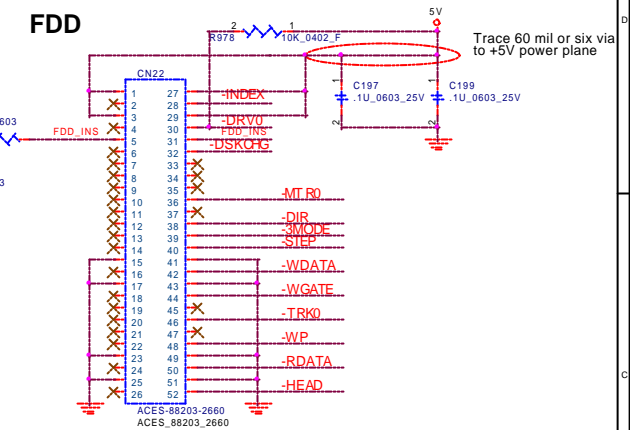
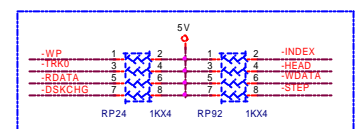
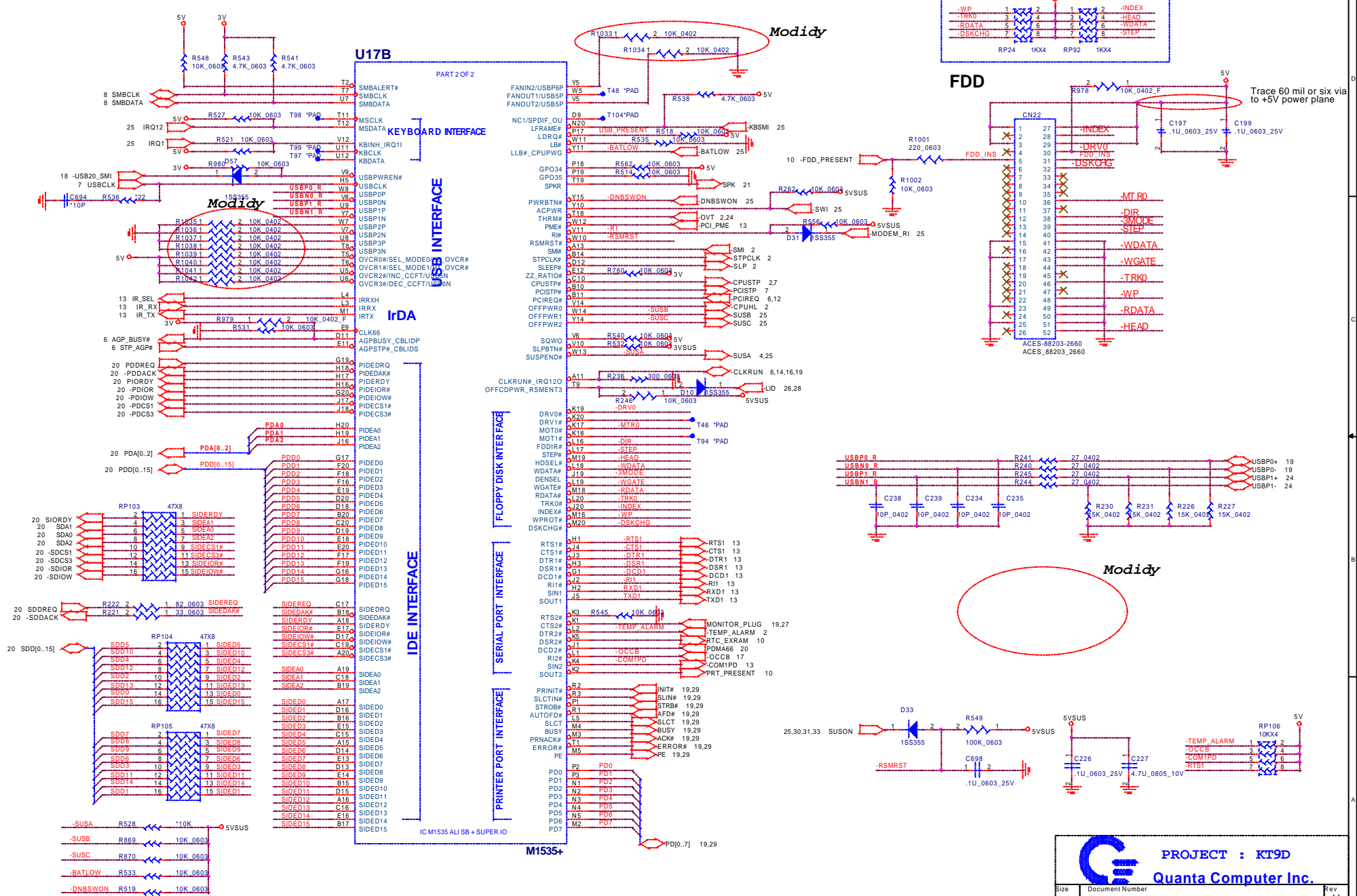

PROJECT : KT9D
Quanta Computer Inc.

Size: Document Number
M1535+ USB,IDE,FDD IF
 Date: Monday, March 17, 2003 Sheet 11 of 35

N.B & S.B H/W STRAPPING

NORTH BRIDGE H/W STRAPPING

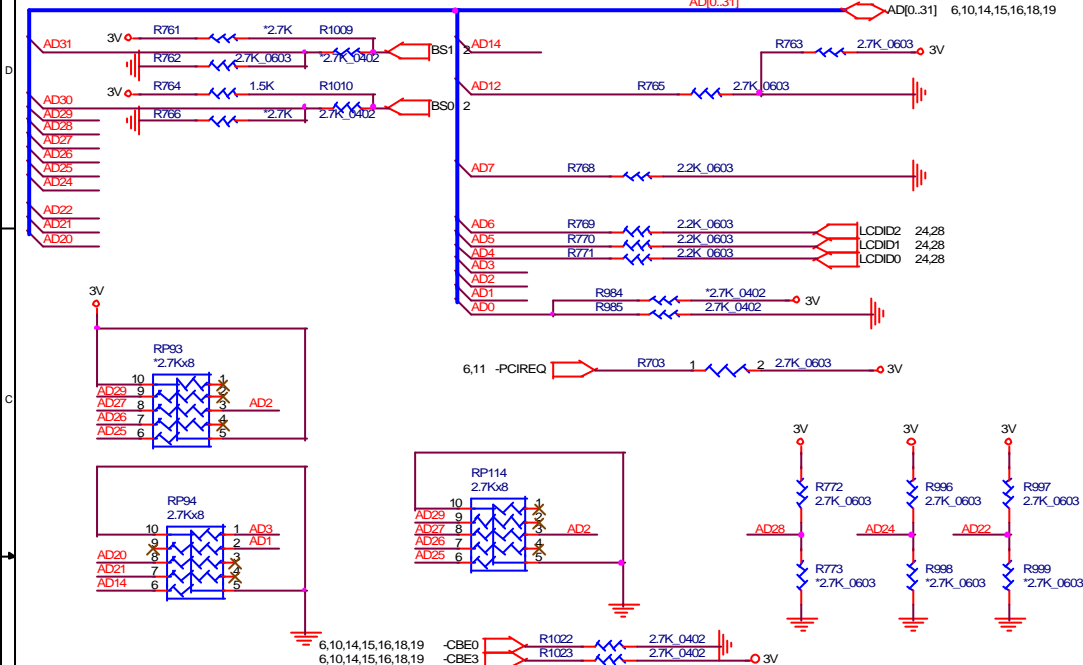

AD[31..30] : CLK SPEED DEFAULT: 00	00: 100 MHz 01: 133 MHz 10: 166MHz 11: 66 MHz	AD15 : RESERVED	
AD29: RS200M FULL CONFIGURATION DEFAULT: 0	0: FULL CONFIGURATION 1: USES DEFAULT VALUES	AD14 : AGTL+ VDDQ DEFAULT: 0	0: 1.2V MOBILE PART 1: 1.7V DESKTOP PART
AD28: SPREAD SPECTRUM ENABLE DEFAULT: 0	0: DISABLE 1: ENABLE	AD13: RESERVED	
AD27: MCERR OBSERVATION DEFAULT: 0	0: DISABLE 1: ENABLE	AD[12] : FLAT PANEL ID MSB	
AD26: QUICK START SELECT DEFAULT : 0	0: DISABLE 1: ENABLE	AD10 : RESERVED	
AD25: INIT OBSERVATION DEFAULT : 0	0: DISABLE 1: ENABLE	AD09 : RESERVED	
AD24: IOQ ENABLE DEFAULT : 1	0: DISABLE 1: ENABLE	AD[7..4] : FLAT PANEL ID	
AD23 : RESERVED		AD3: PCI66 MODE DEFAULT: 0	0: 33MHz 1: 66MHz
AD22: 27MHz/33 MHz CLOCK SELECTION DEFAULT : 1	0: 33 MHz CLOCK OUTPUT 1: 27 MHz CLOCK INPUT	AD2: CAL DEFAULTS FOR CPU DEFAULT: 0 (FOR BRING UP)	0: DISABLE 1: ENABLE
AD21 : RESERVED	0: PLL Bypass mode disable(Normal mode) 1: PLL Bypass mode enable(Debug only)	AD1: FrcShortReset DEFAULT: 0	0: DISABLE 1: ENABLE
AD20 : PCICLK EXPANSION DEFAULT : 0	1: PCI_REQ#3, PCI_GNT#3 USED AS PCICLK 0: PCI_REQ#3, PCI_GNT#3 USED AS REQ/GNT	AD0: PCI/AGP CONFIG. DEFAULT : 0	0: 33 MHz 1: 66 MHz
CBE#3: PROD TEST DEFAULT : 1	0: SHORT TIMERS 1: NORMAL OPERATION	-PCI_REQ: INTERNAL CLOCK GEN. DEFAULT : 1	0: DISABLE 1: ENABLE

SOUTH BRIDGE H/W STRAPPING

	DTR2#	RTS2#	RTS1#	CLK320	SPLD	SQWO
PULL HIGH	INTERNAL KEYBOARD PS2 MODE DEFAULT	ENABLE INTERNAL KEYBOARD	SIO BASE ADDRESS 0X3F0h	32K CLOCK TEST MODE ENABLE	AT POWER MODE	PENTIUM II MODE DEFAULT
PULL LOW	INTERNAL KEYBOARD AT MODE	DISABLE INTERNAL KEYBOARD DEFAULT	SIO BASE ADDRESS 0X370h DEFAULT	32K CLOCK TEST MODE DISABLE DEFAULT	ATX POWER MODE DEFAULT	PENTIUM / K7 MODE DEFAULT

PCS1#	PCS0#	GPO34	LB#	GPO30[AEN]	GPO29	ROMCS#	GPO35
GP124 & GPO30 FUNCTIONS	DISABLE 4Mb FLASH ROM MODE	CHIP TEST MODE DISABLE DEFAULT	ACTIVE HIGH TO POWER OFF	L, L - USB TEST MODE L, H - AUDIO/MODEM TEST MODE H, L - SUPER IO TEST MODE H, H - NORMAL OPERATION		FLASH ROM MODE SELECTION L, L - RESERVED L, H - ENABLE 8Mb Flash ROM SIZE H, L - DISABLE ALL FUNC. IN THIS CONFIG. H, H - ENABLE LPC FLASH ROM	
IO CHRDY & AEN FUNCTIONS	ENABLE 4Mb FLASH ROM MODE	CHIP TEST MODE ENABLE	ACTIVE LOW TO POWER OFF DEFAULT	DEFAULT : H, H		DEFAULT : H, L	



PROJECT : KT9D
Quanta Computer Inc.

Size	Document Number	Rev
	N.B & S.B H/W STRAPPING	1A
Date:	Monday, March 17, 2003	Sheet 12 of 35

SERIAL PORT

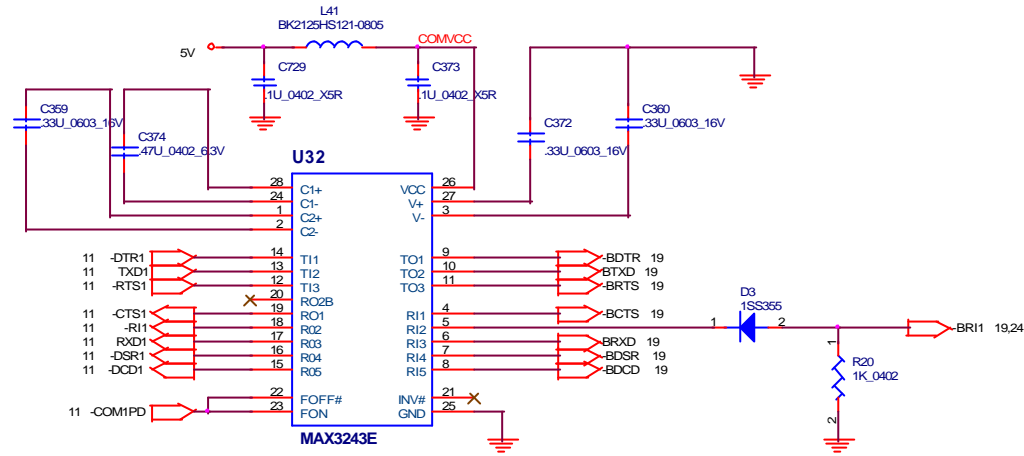

FIR CON

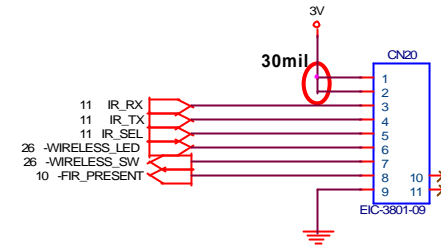

PME CONTROL

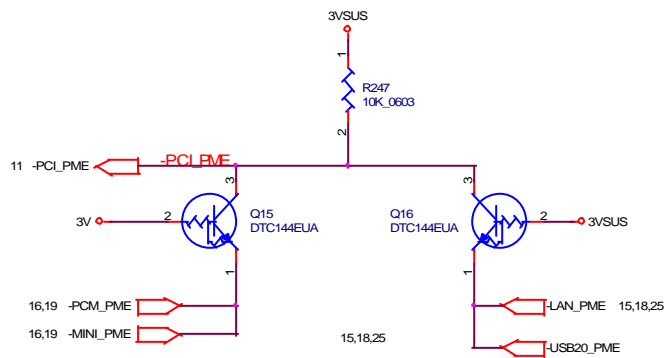

RTC POWER CIRCUIT

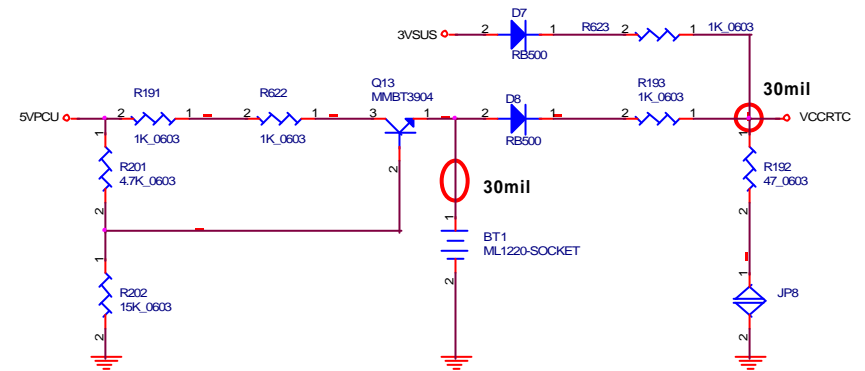

PROJECT : KT9D
Quanta Computer Inc.

Size	Document Number	Rev
SERIAL PORT&RTC&FIR CON		1A
Date:	Monday, March 17, 2003	Sheet 13 of 35

1394 CONTROLLER_TI - TSB43AB21

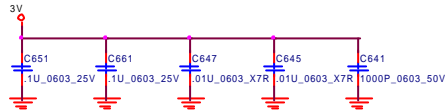

Used for vccp (Pin20,35,48,62,78)

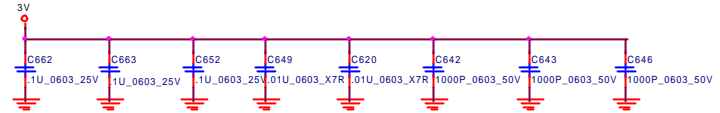

Used for vcc3 (Pin15,27,39,51,59,72,88,100)

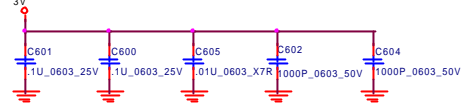

Used for AVCC (Pin1,2,107,108,120)

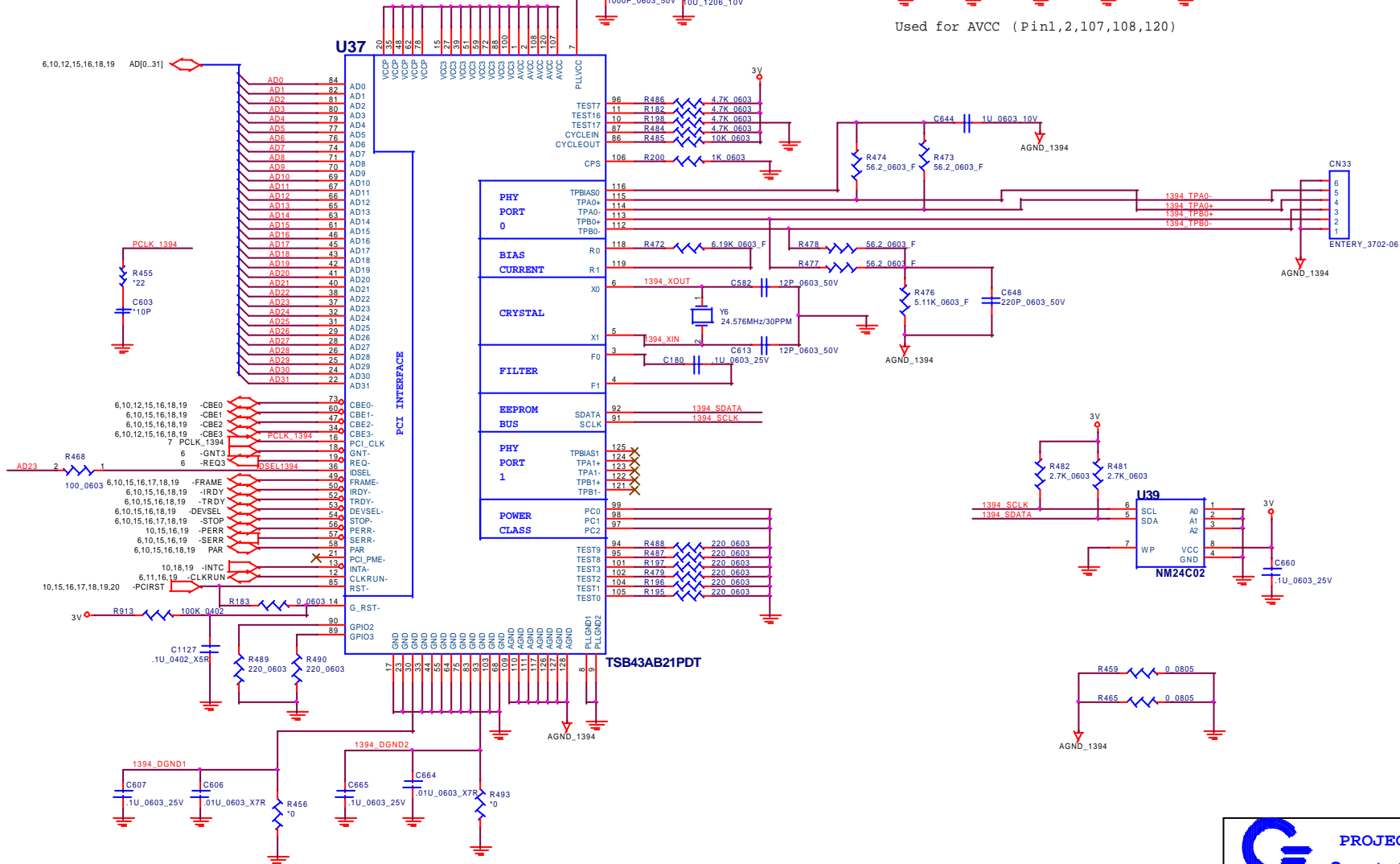

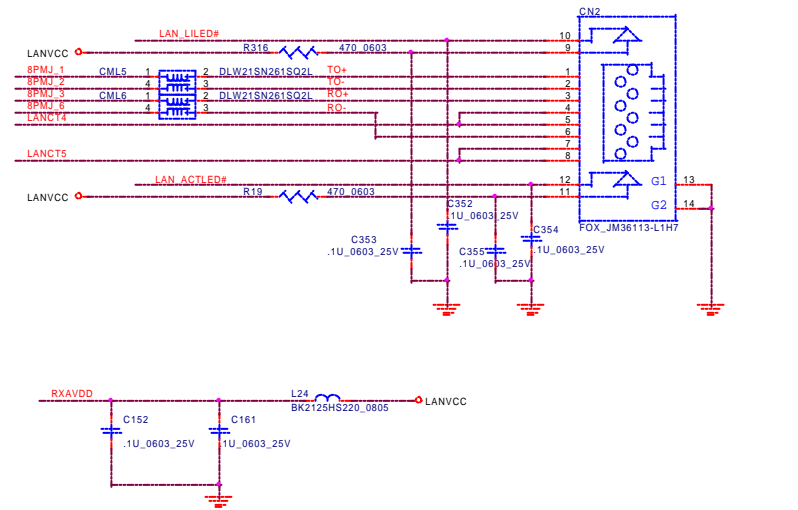
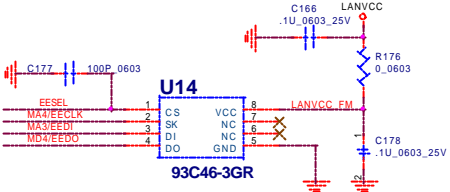
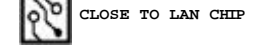
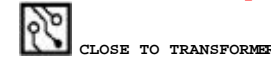
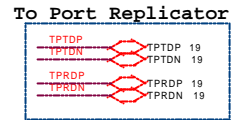
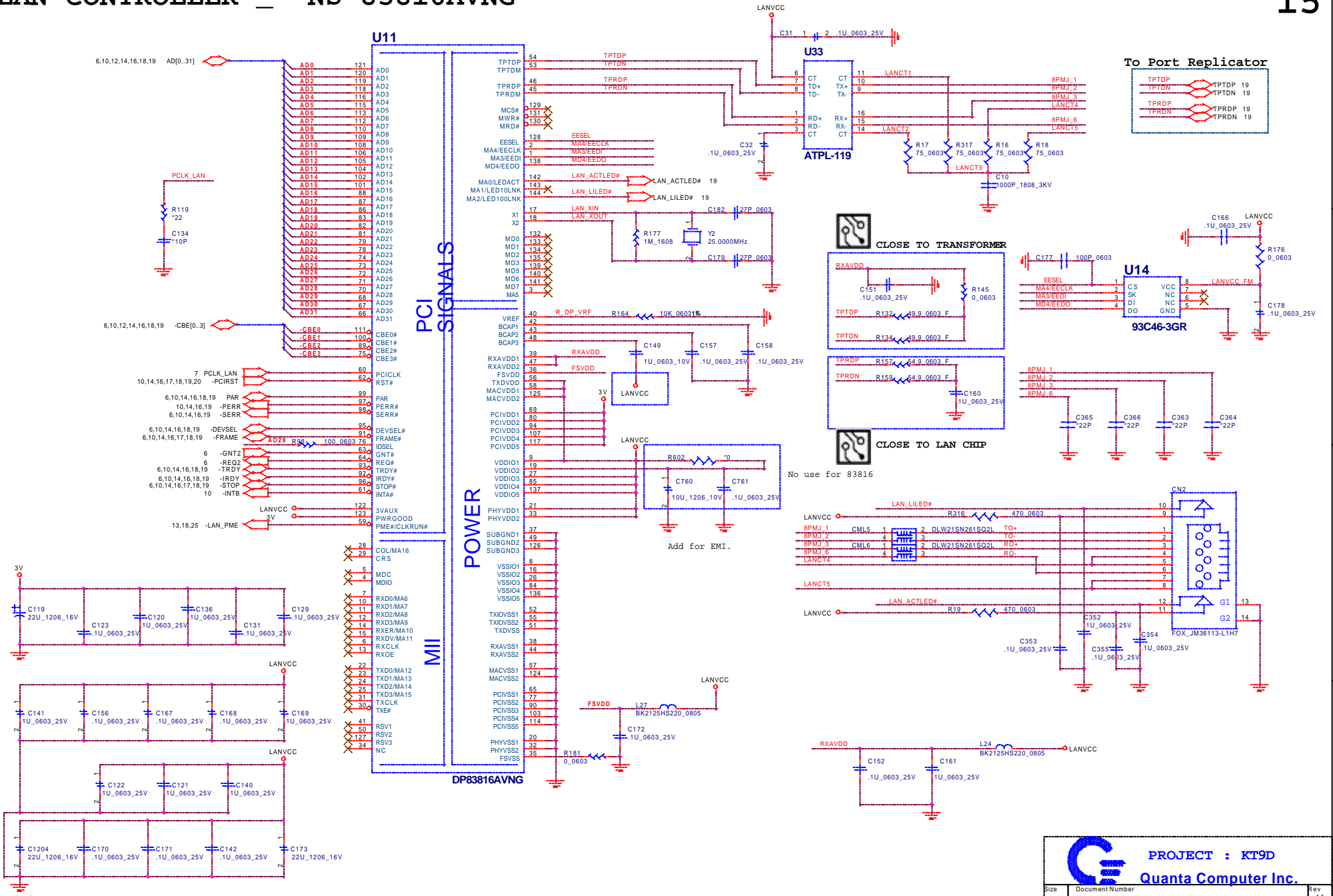

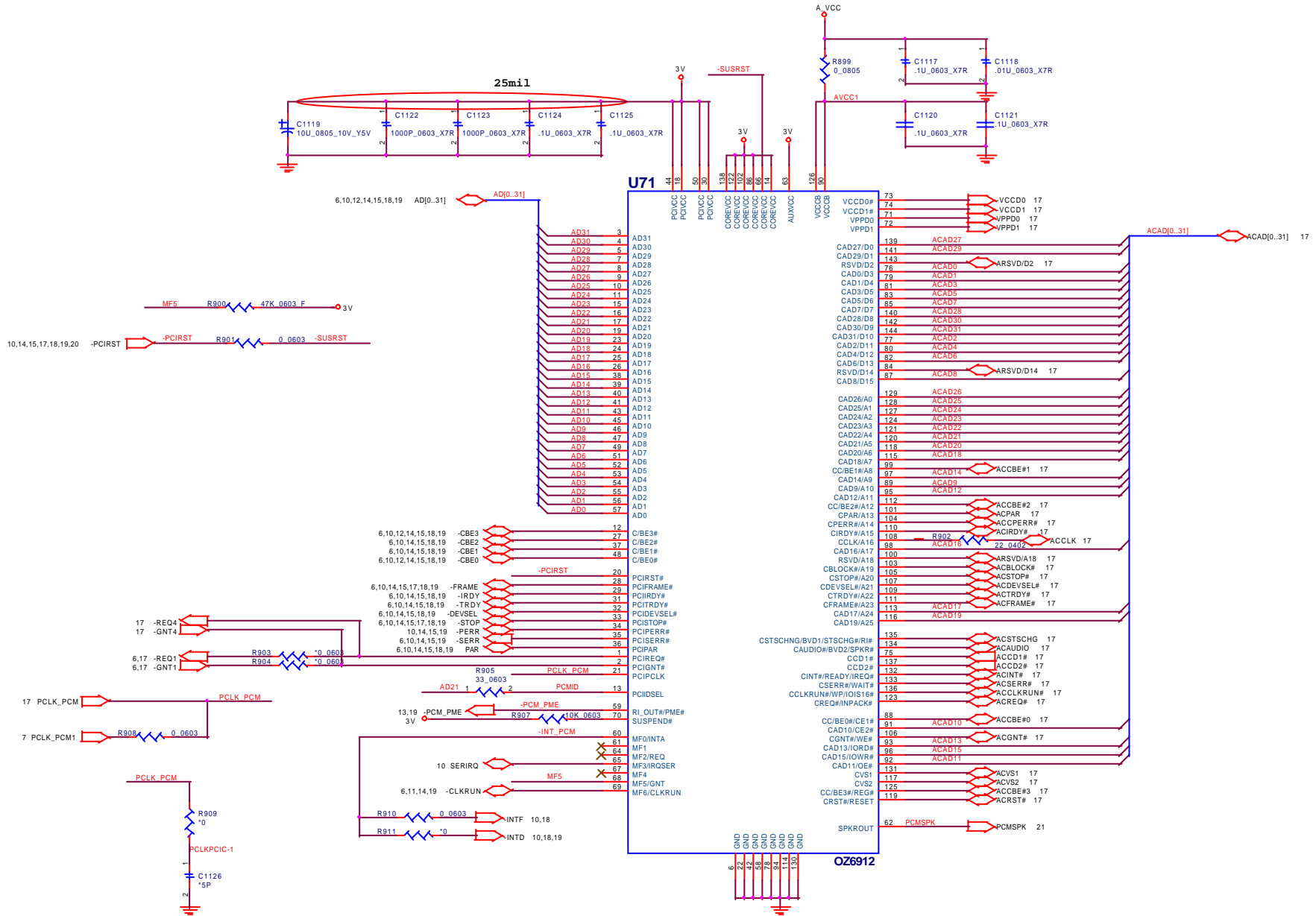

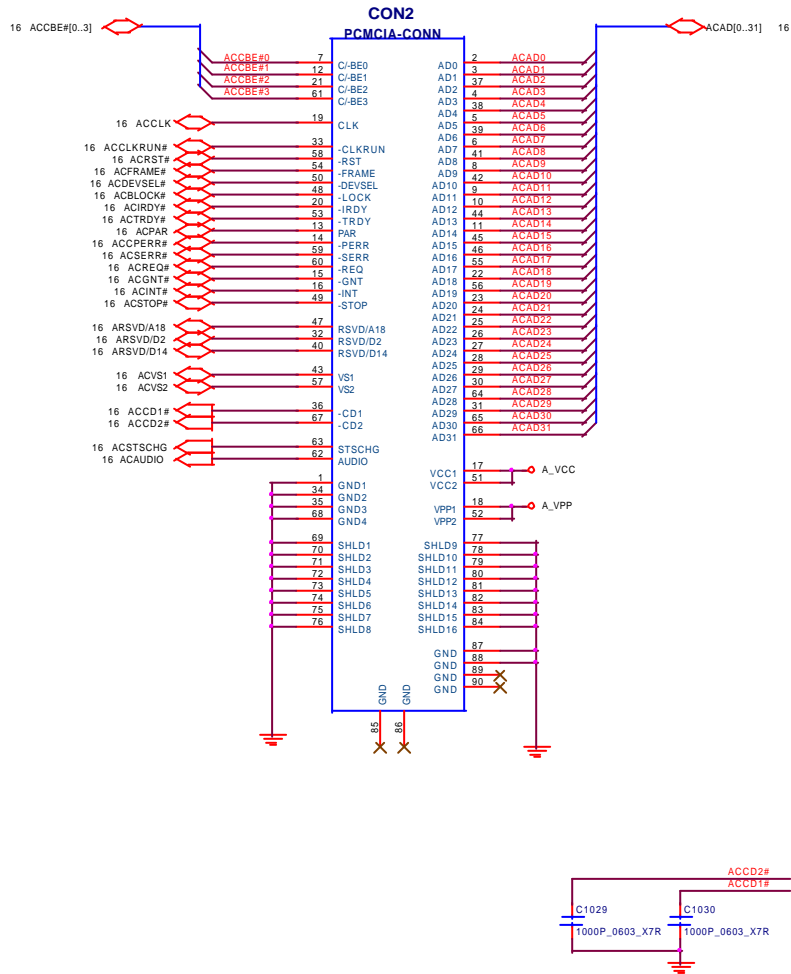

CARDBUS POWER SWITCH

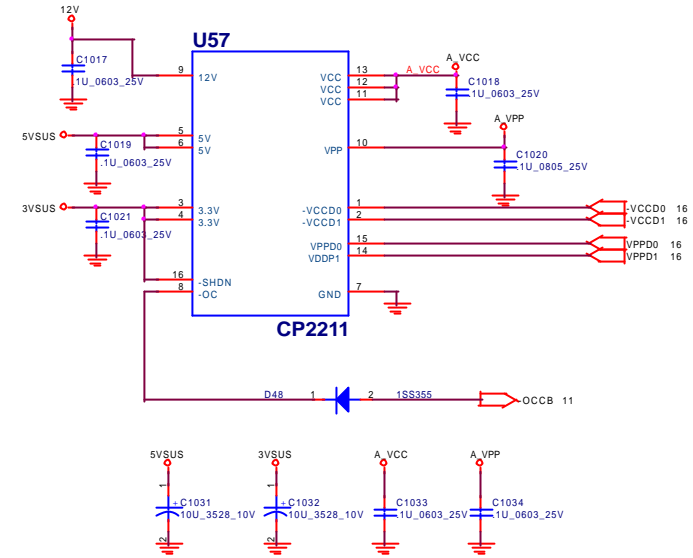

PCI HUB_ENE-ASIC1

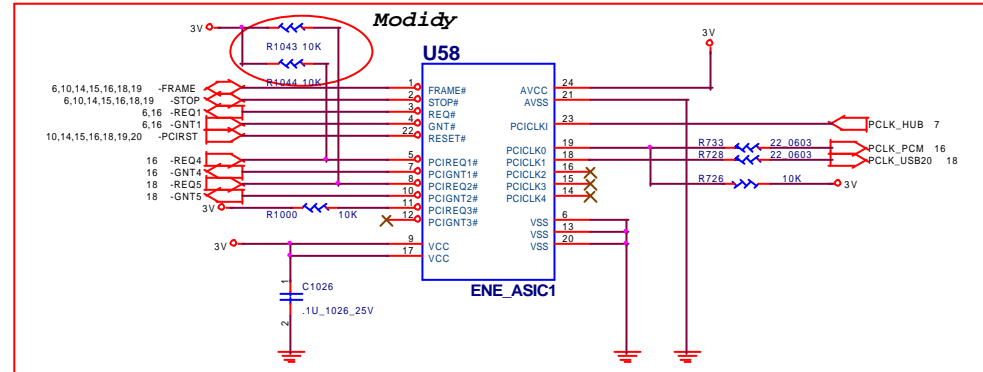

USB2.0 CONTROLLER_VIA-6202

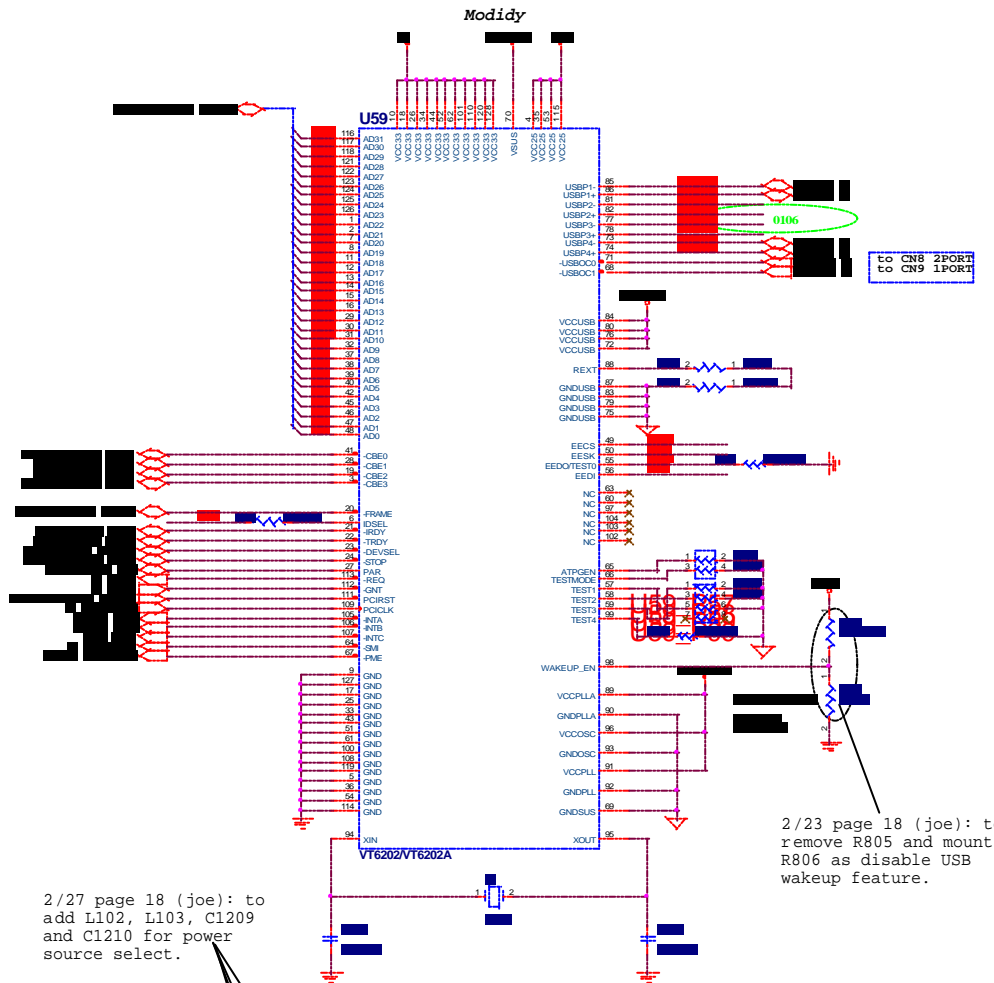

2/18 (joe): to reserve USB2.0 switching circuits by BOM change.

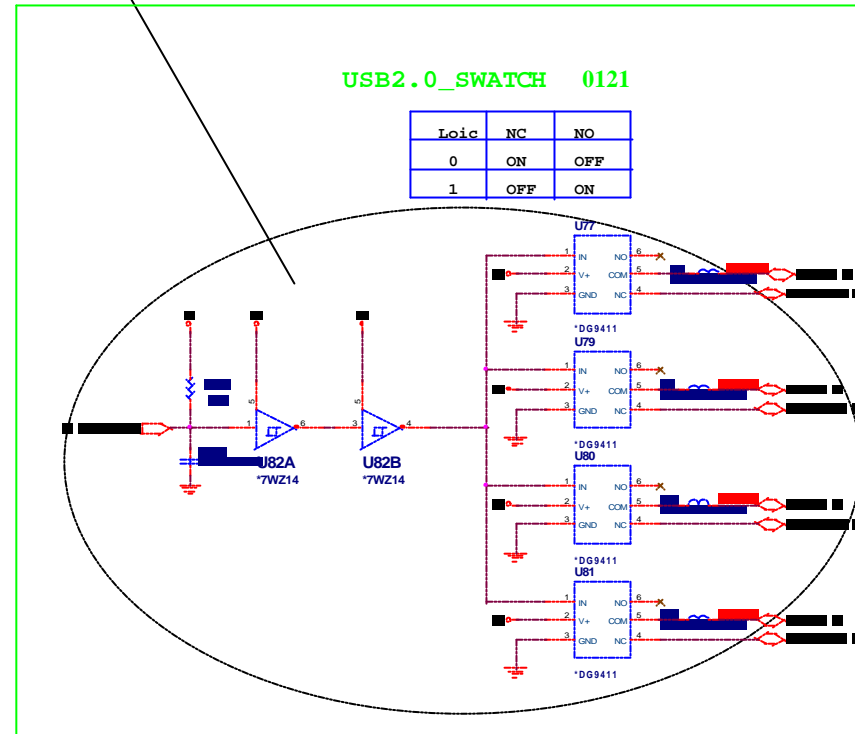

2/27 page 18 (joe): to add L102, L103, C1209 and C1210 for power source select.

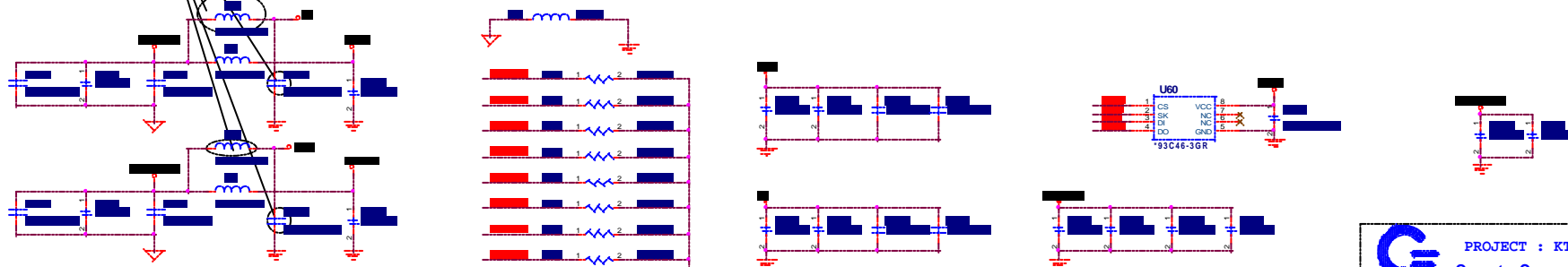

HDD CONNECTOR

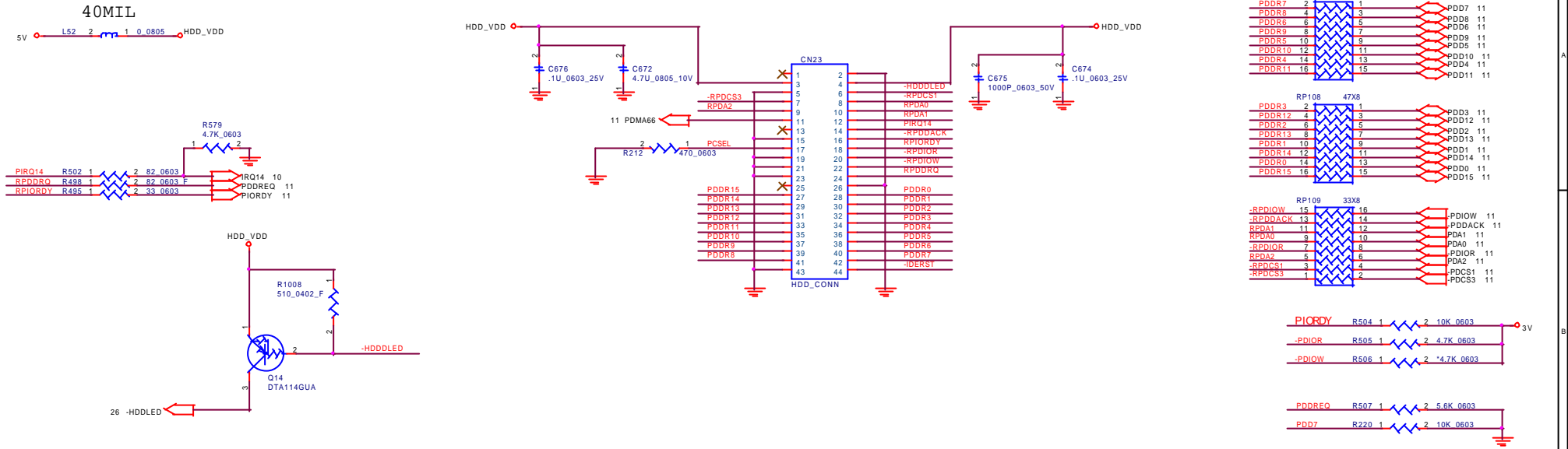

CD-ROM CONNECTOR

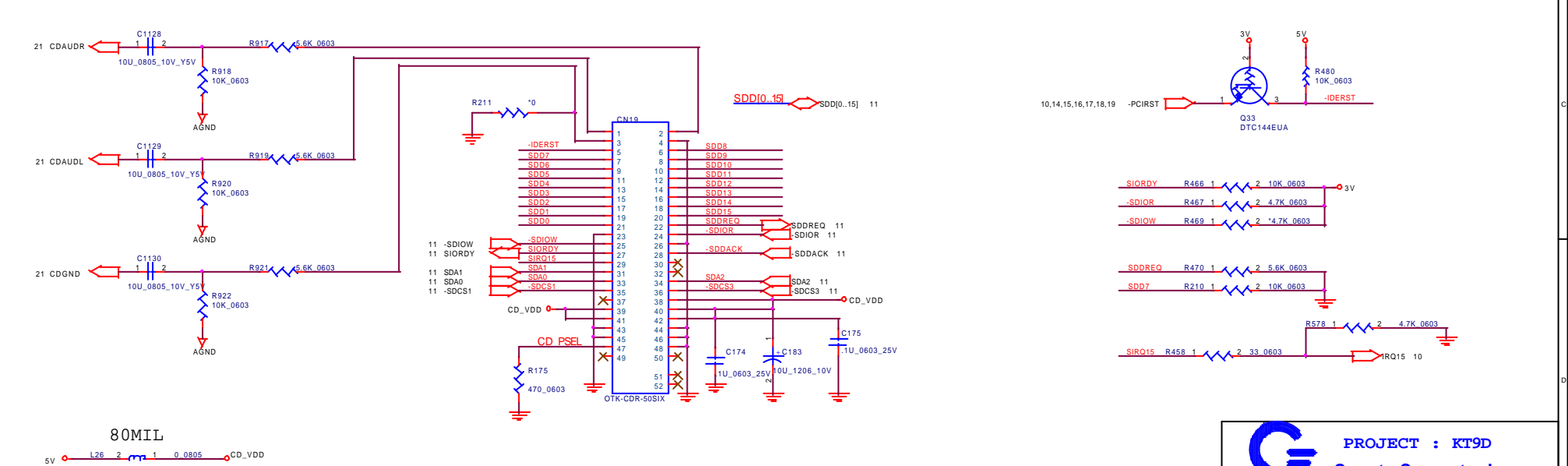

PROJECT : KT9D
Quanta Computer Inc.

Size	Document Number	Rev
	IDE INTERFACE	1A
Date	Monday, March 17, 2003	Sheet 20 of 35

The AMC20493-001 modem is used for mother board family MBAMC20493-006.

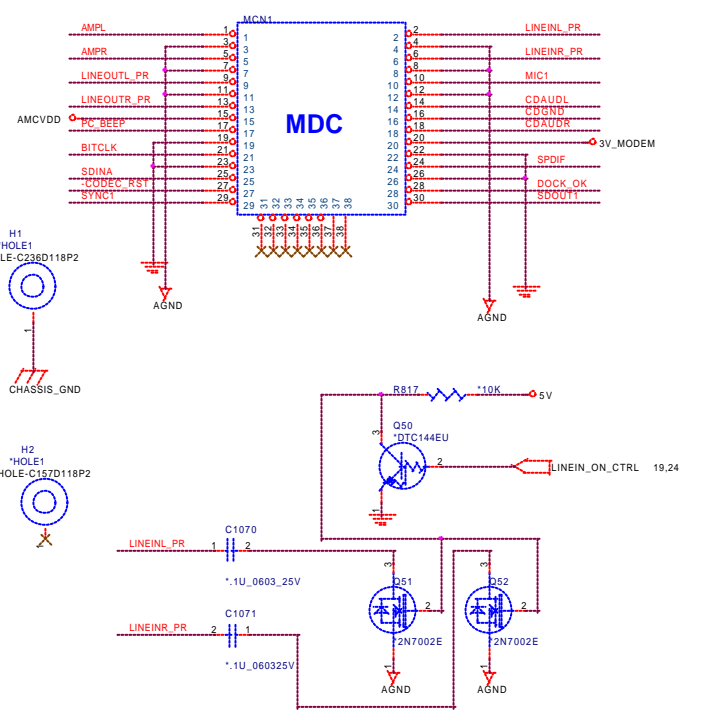
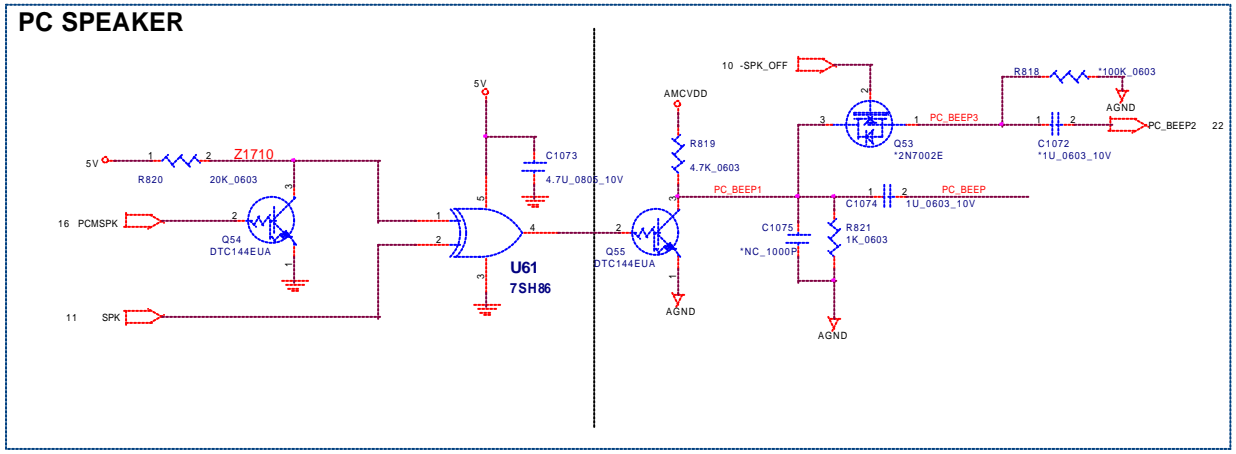
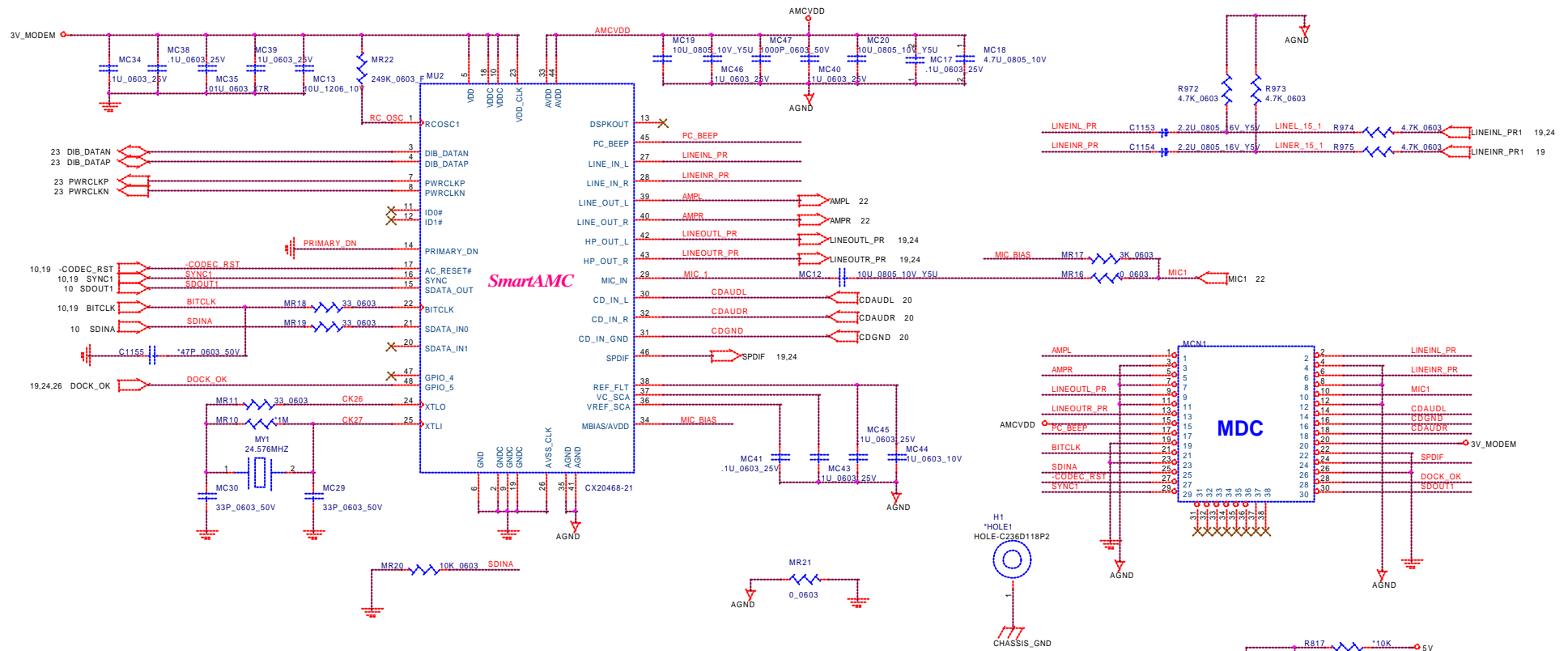

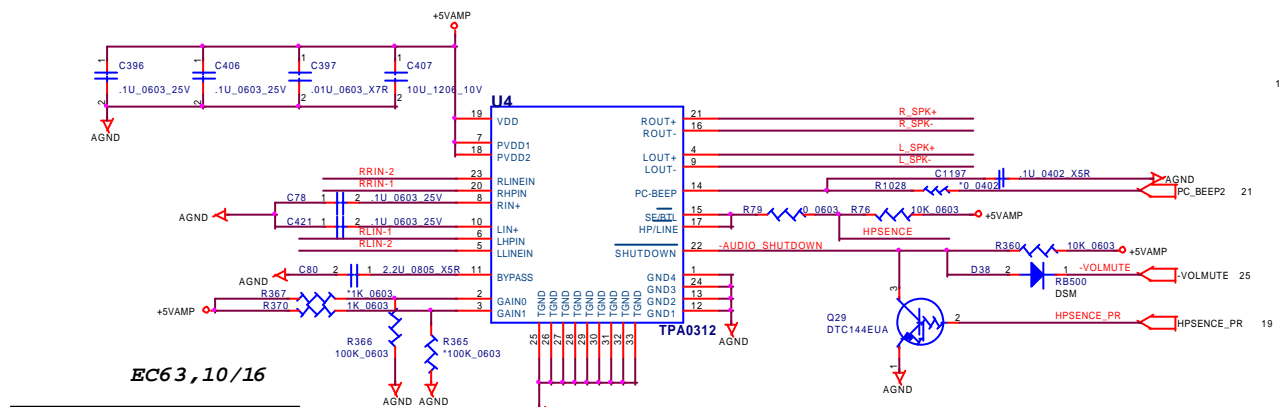
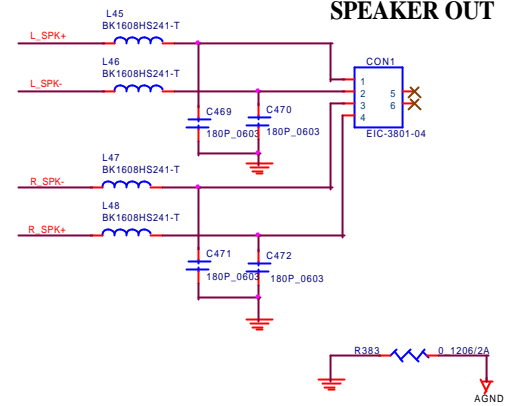
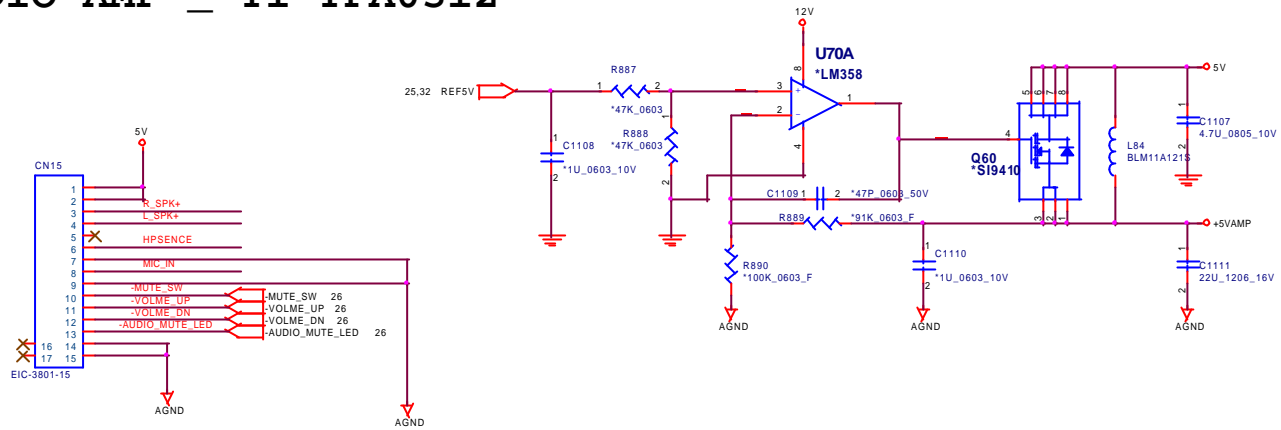

EC63, 10/16

Gain0	Gain1	Av
0	0	6dB
0	1	10dB
1	0	15.6dB
1	1	21.6dB

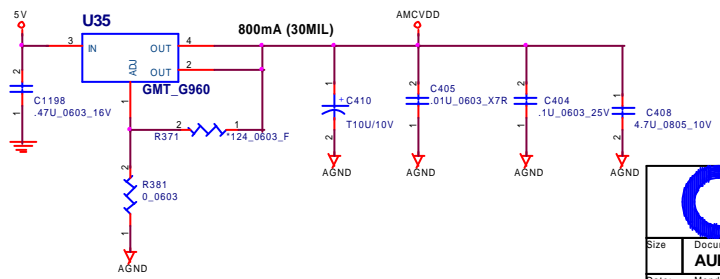
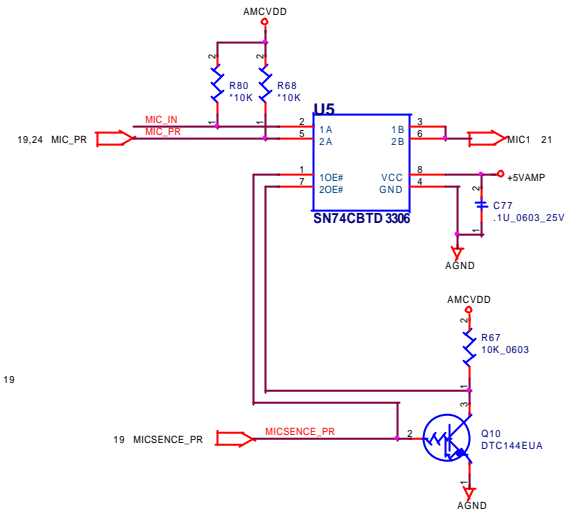
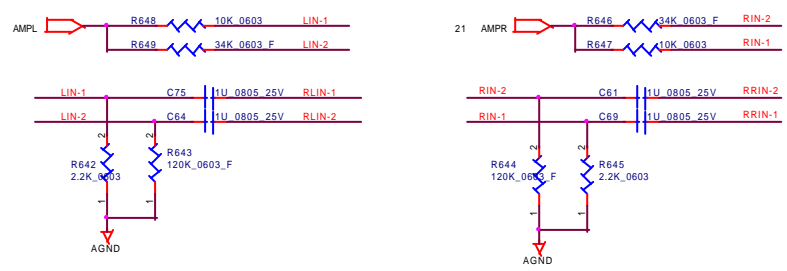

PROJECT : KT6B
Quanta Computer Inc.

Size	Document Number	Rev
Date	AUDIO AMP _ TI-TPA0312	1A
Monday, March 17, 2003	Sheet 22 of 35	

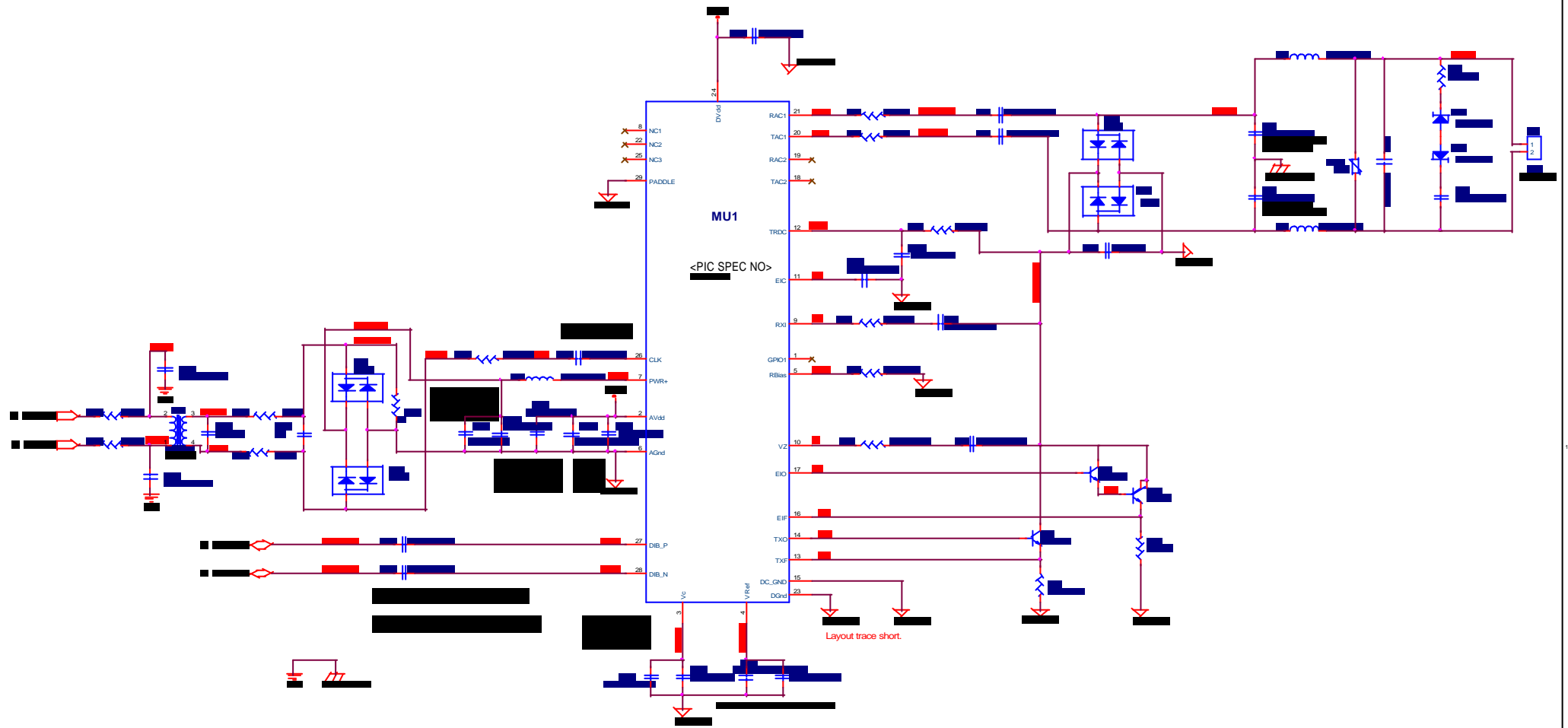

EMI

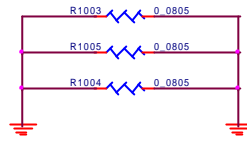
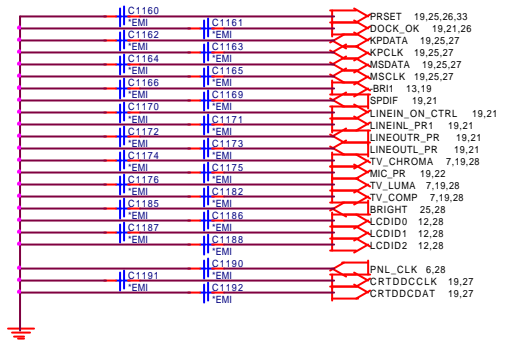

CARD READER (Option)

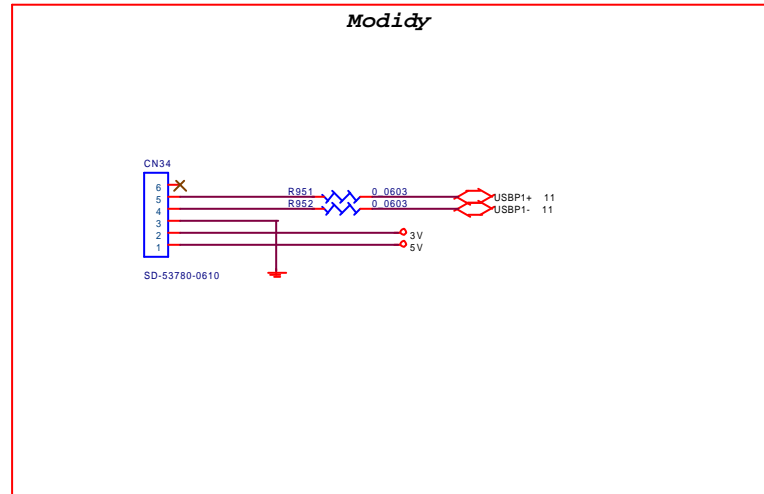

FAN CONTROL

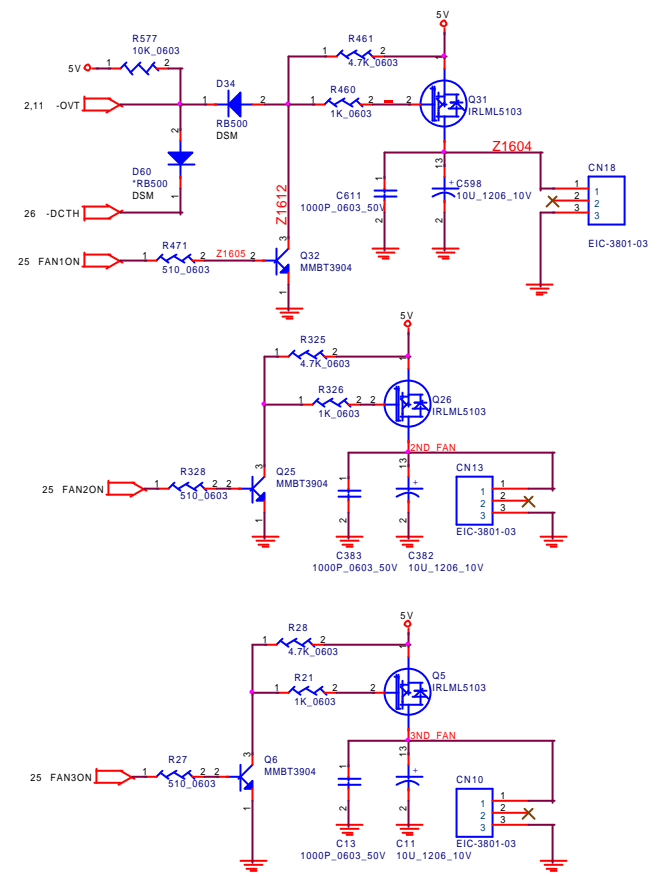

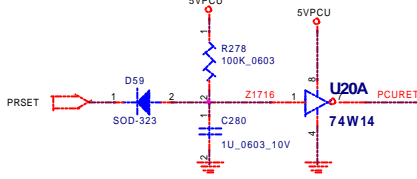
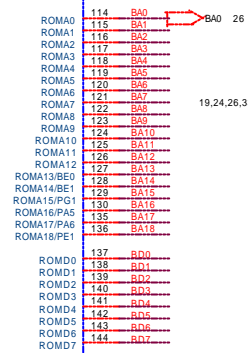
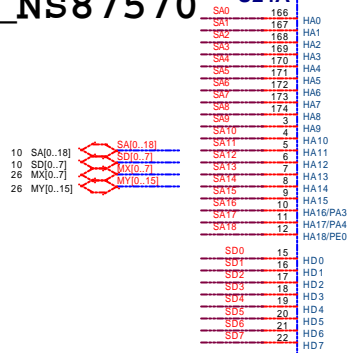

U20A

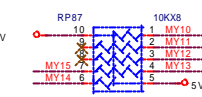

RP87

RP91

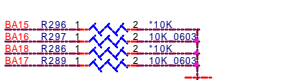

ROMS

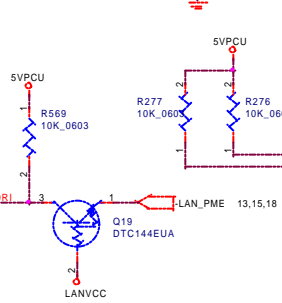
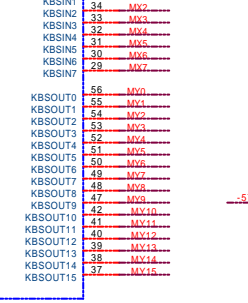
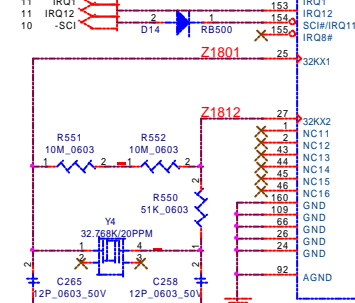

LAN

VPP

U42

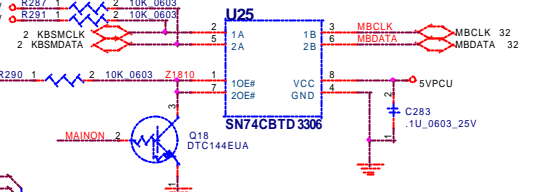

FOR EMI NEAR KEYBOARD CONNECTOR

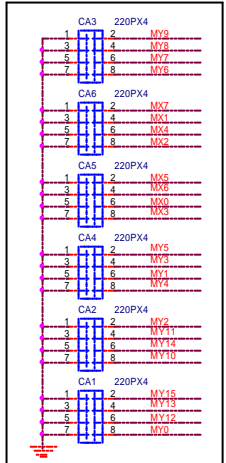

U27

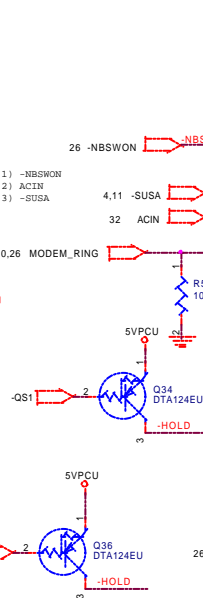
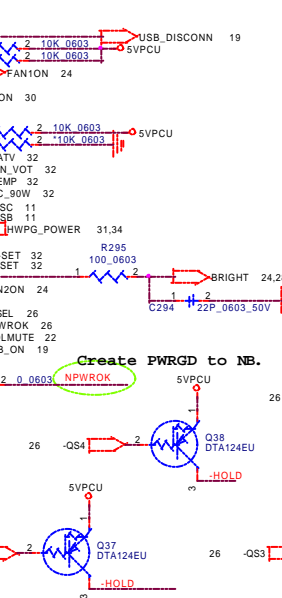
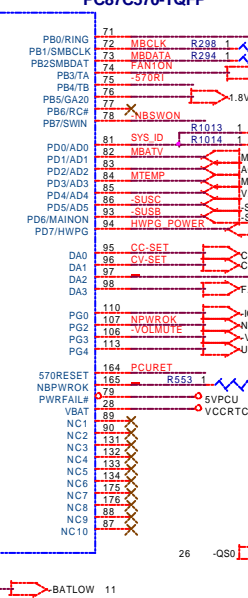
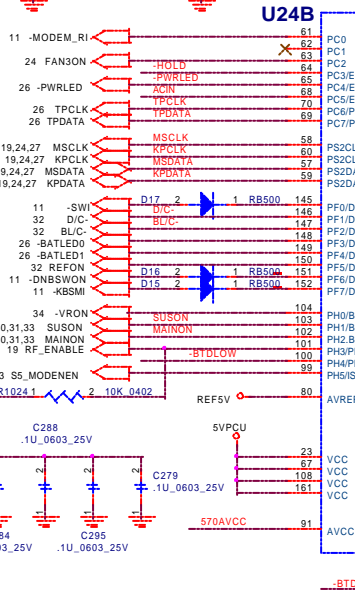

U29

USB/CRT/PS2 PORT

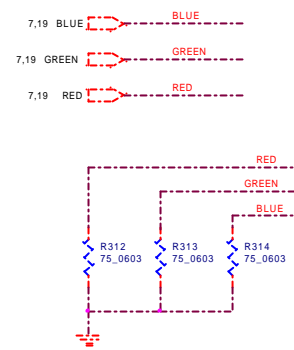
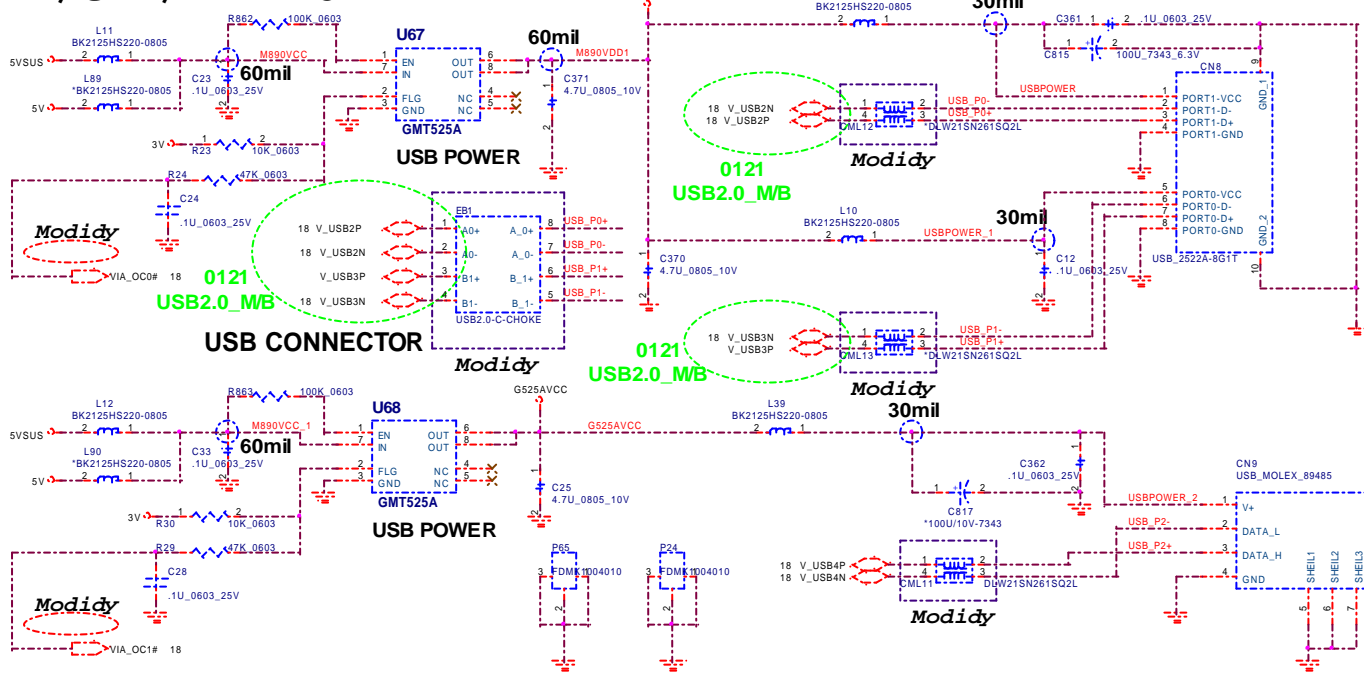

CRT PORT

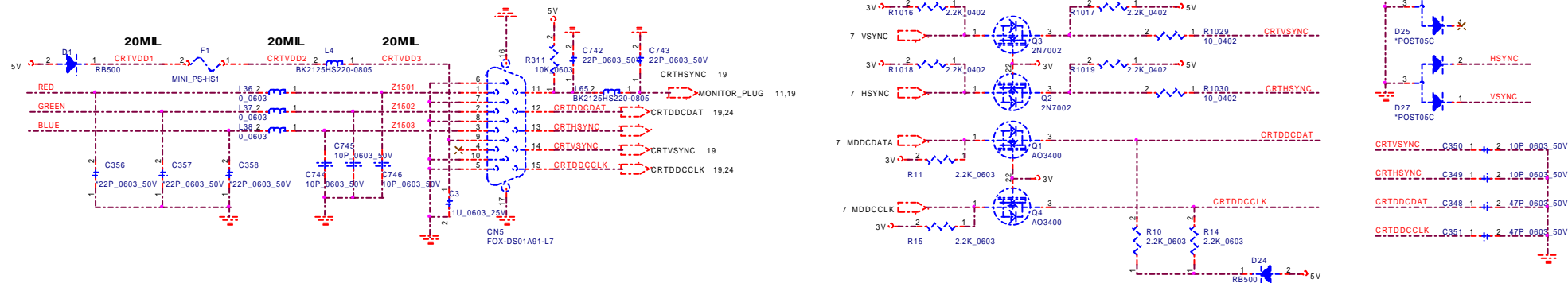

PS/2 PORT

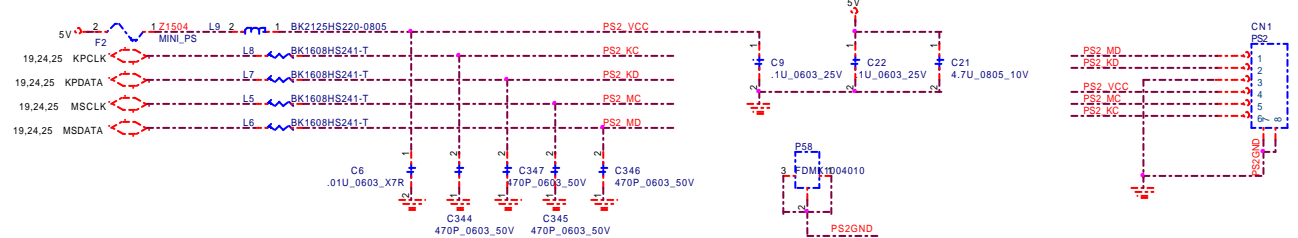

PROJECT : KT9D
 Quanta Computer Inc.
 Size Document Number
USB/CRT/PS2 PORT
 Date: Monday, March 17, 2003 Sheet 27 of 35 Rev 1A

PARALLEL PORT INTERFACE

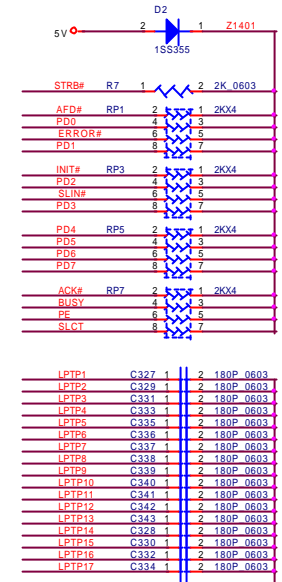
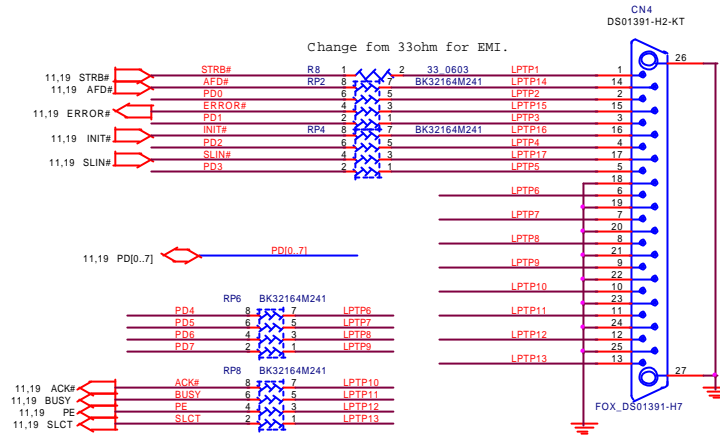
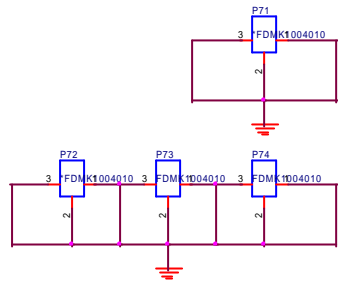

EMI FENSES

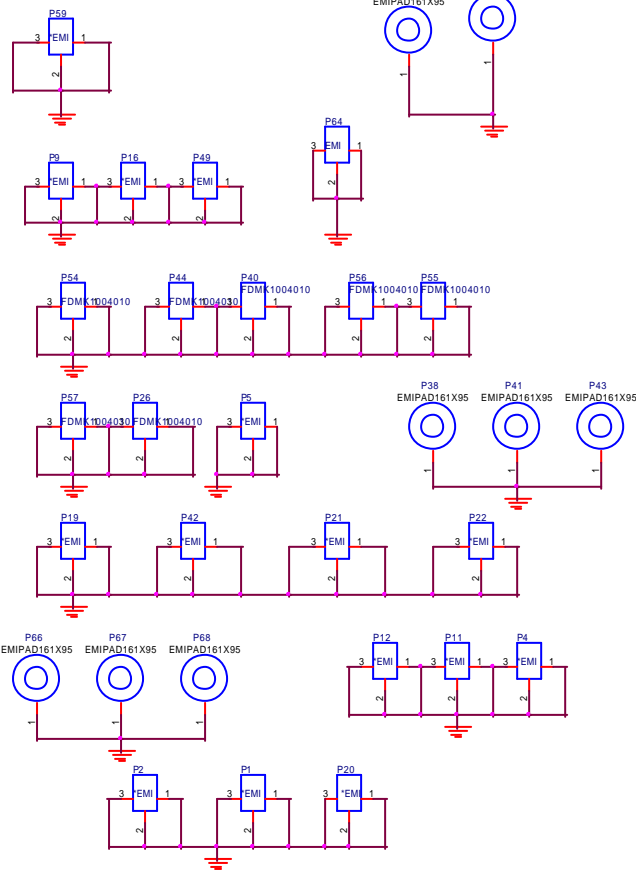

SCREW HOLES

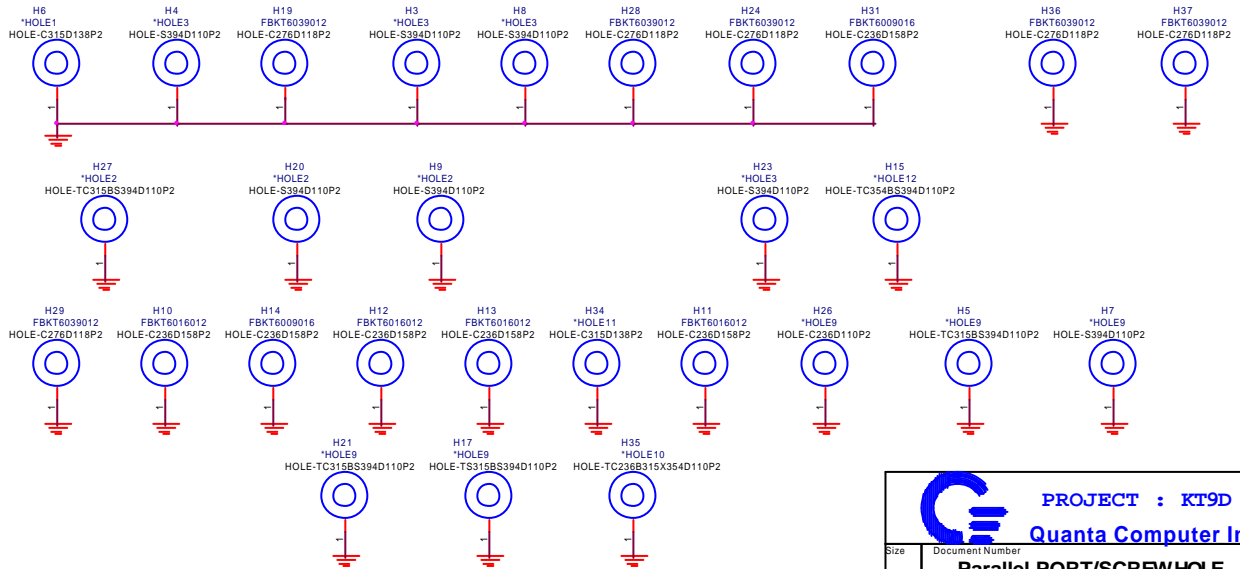



PROJECT : KT9D
Quanta Computer Inc.

Size Document Number
Parallel PORT/SCREW HOLE Rev 1A

Date: Monday, March 17, 2003 Sheet 29 of 35

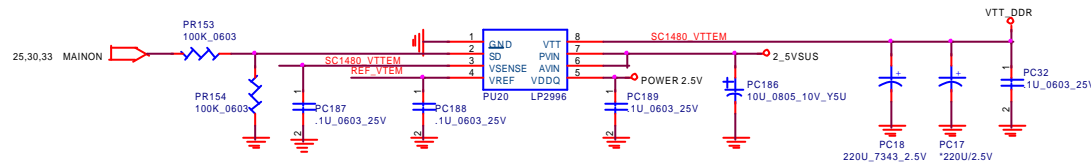
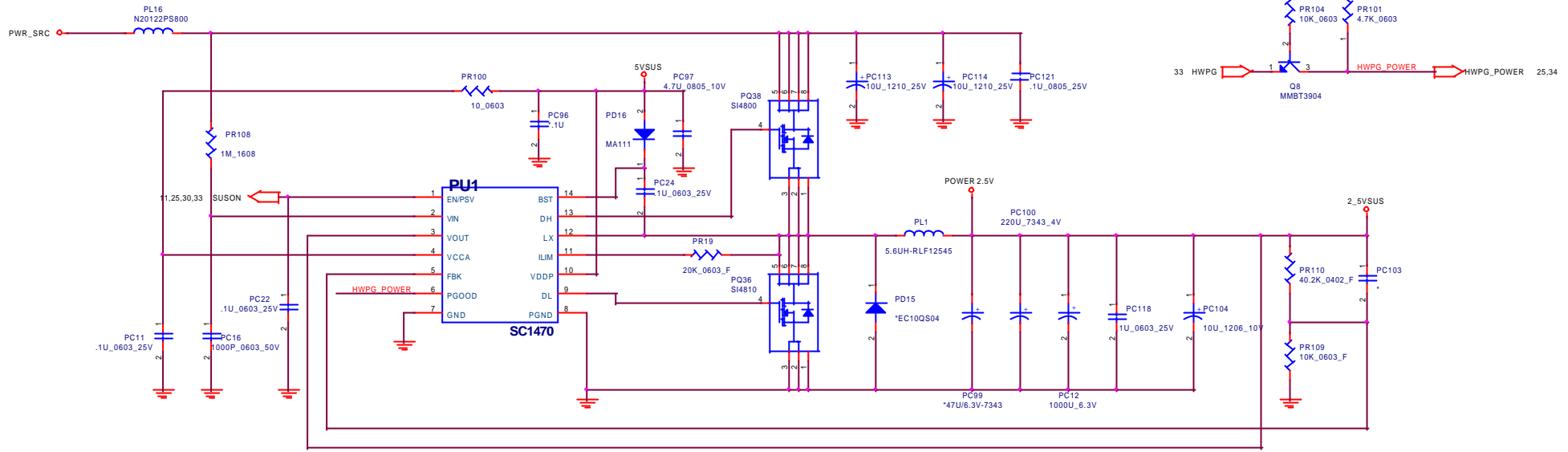
SYS POWER_ 2.5V & DDR TERMINAL POWER



		PROJECT : KT9D	
		Quanta Computer Inc.	
Size	Document Number	Rev 1A	
2.5V & DDR TERMINAL POWER			
Date:	Monday, March 17, 2003	Sheet	31 of 35

BATTERY CONN&POWER JACK

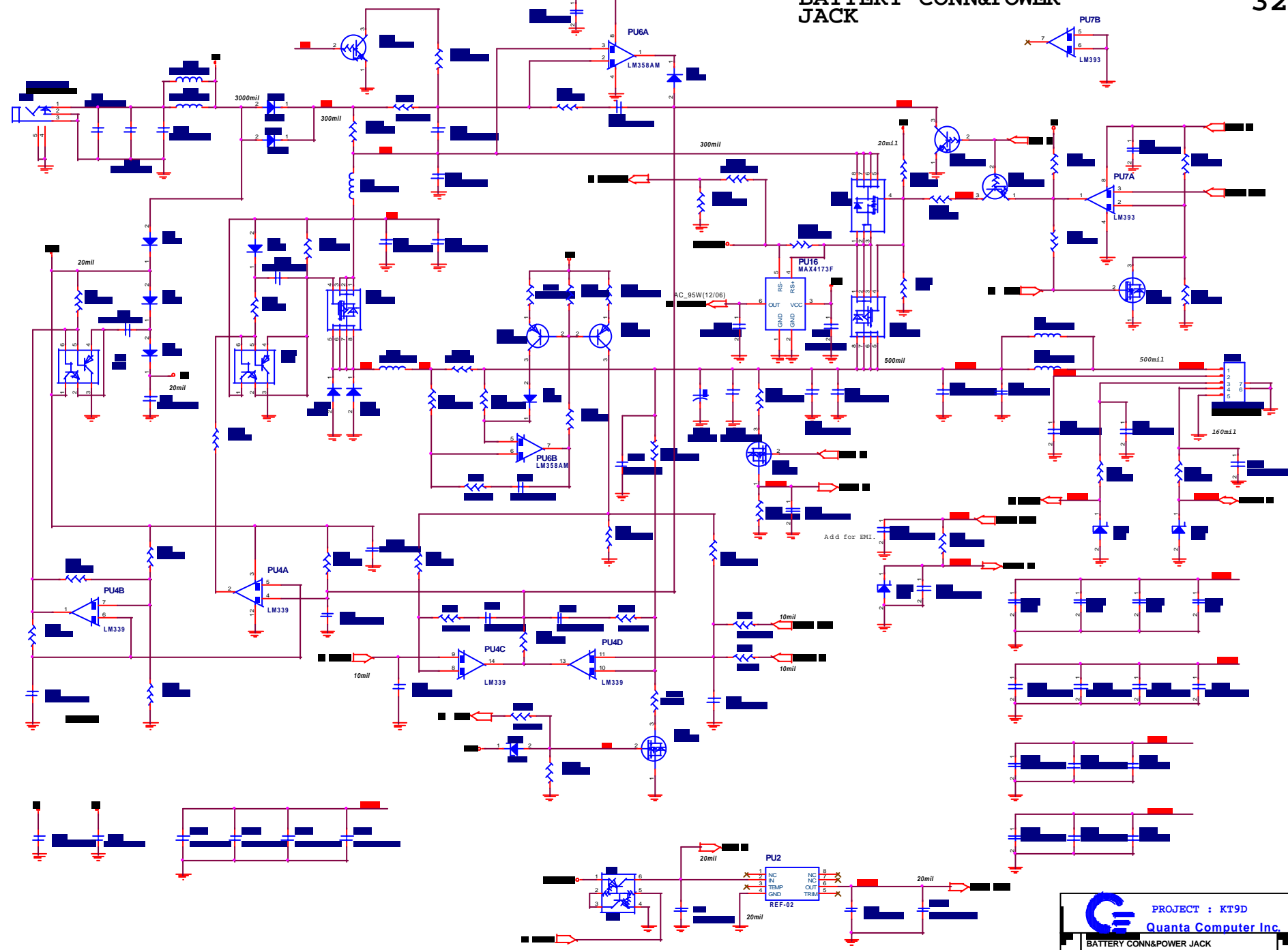

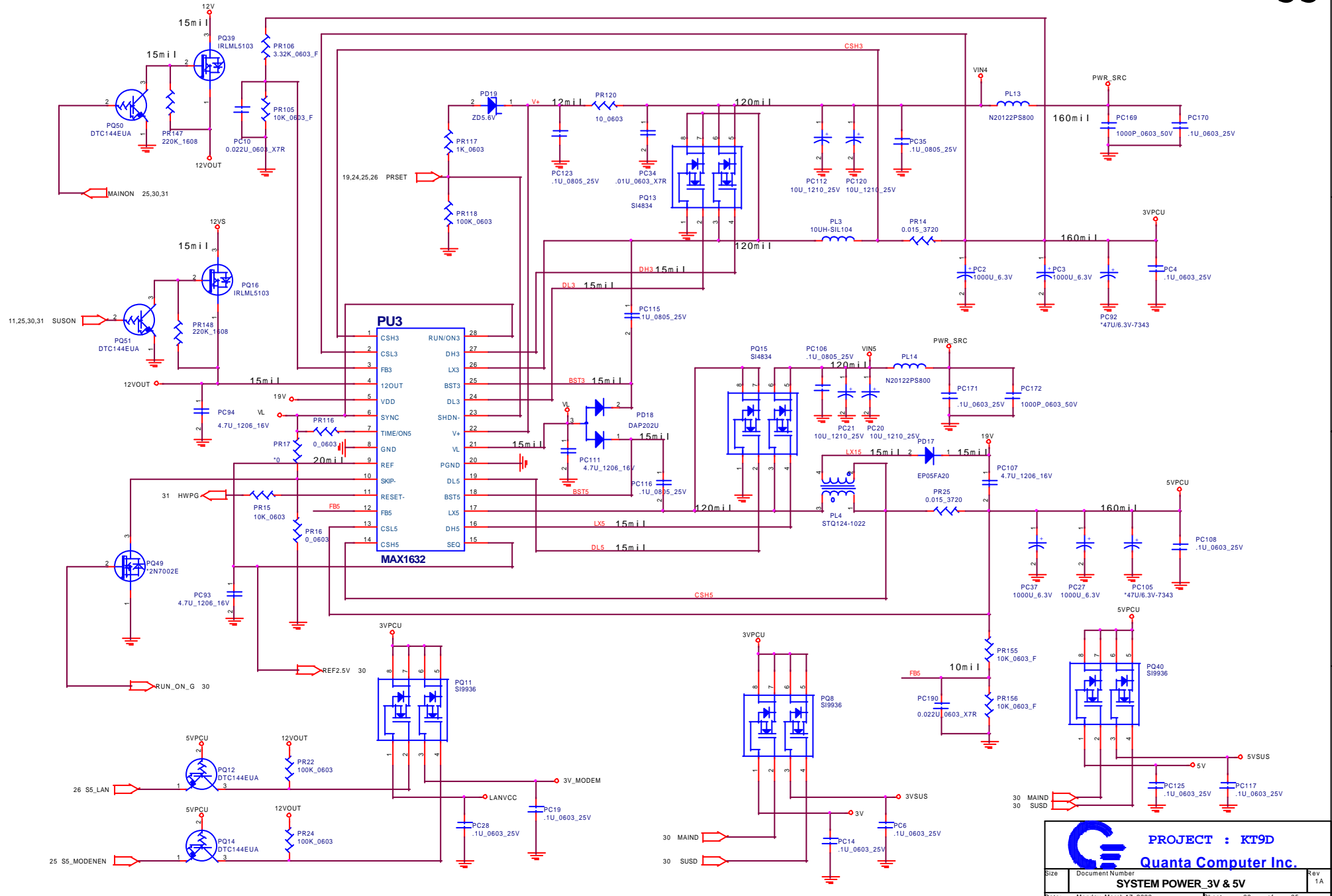

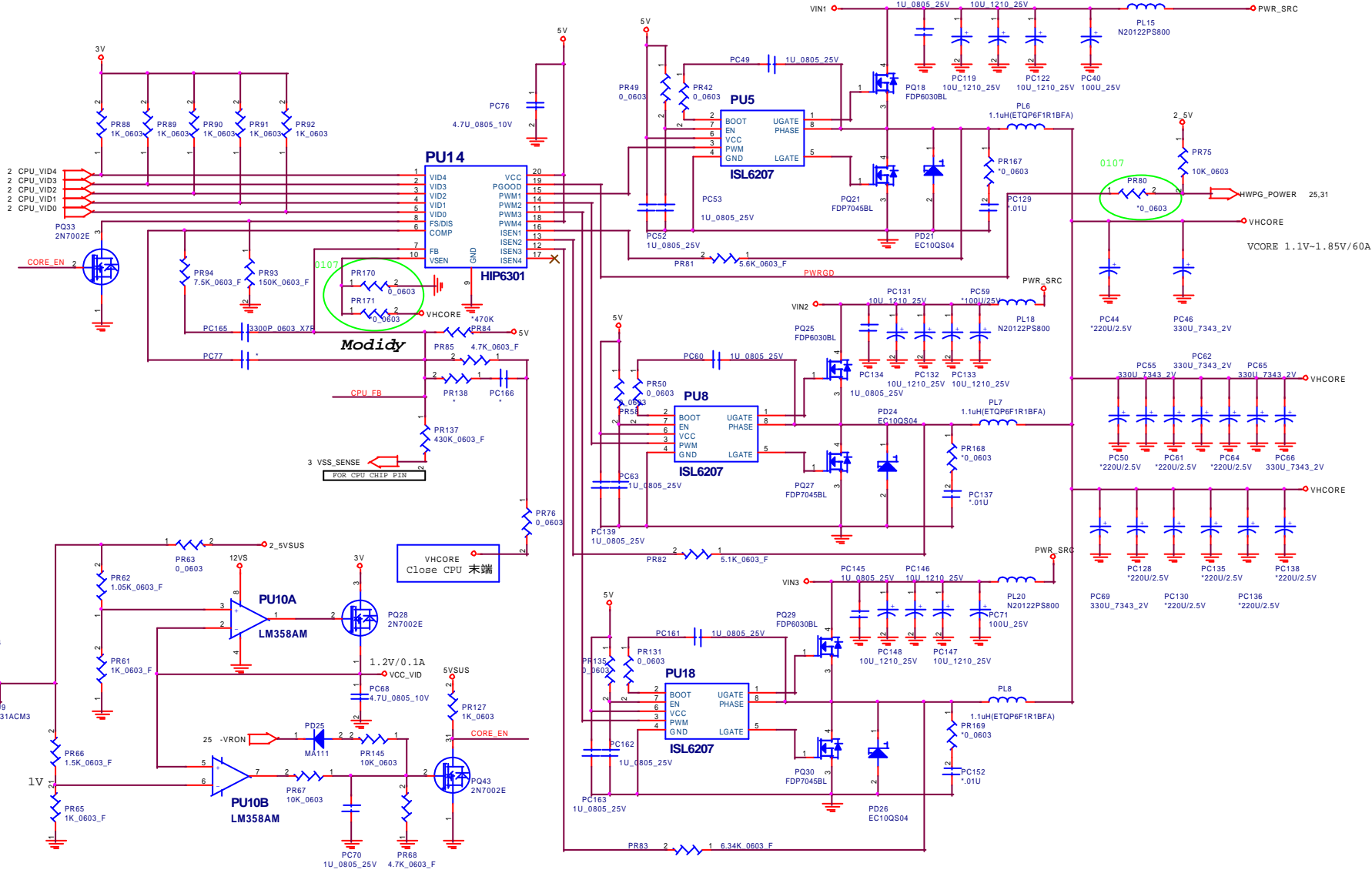

		
PROJECT : KT9D		
Quanta Computer Inc.		
Size	Document Number	Rev
	SYSTEM POWER_3V & 5V	1A
Date	Monday, March 17, 2003	Sheet 33 of 35

HIP6301 FOR INTEL Brookdale POWER CKT-DDR



		PROJECT : KT9D	
		Quanta Computer Inc.	
Size	Document Number	SYS POWER_VCORE-HIP6301	
Date	Monday, March 17, 2003	Sheet	34 of 35

MODEL	REV	CHANGE LIST	MODEL			
			PAGE	FROM	TO	
KT9D Main Board	1A PV	First Release	01	1A		
			02	1A		
			03	1A		
				04	1A	
				05	1A	
				06	1A	
				07	2A	
				08	1A	
				09	1A	
				10	1A	
				11	1A	
				12	1A	
				13	1A	
				14	1A	
				15	1A	
				16	1A	
				17	1A	
				18	3C	
				19	2A	
				20	2A	
				21	2A	
				22	2A	
				23	1A	
				24	1A	
				25	1A	
				26	1A	
				27	1A	
				28	1A	
				29	1A	
				30	1A	
				31	1A	
				32	1A	
				33	1A	
				34	1A	

PROJECT : KT9D
Quanta Computer Inc.

Size	Document Number	Rev
RELEASE NOTE		1A
Date:	Monday, March 17, 2003	Sheet 35 of 35