

# Welch's BLOCK DIAGRAM

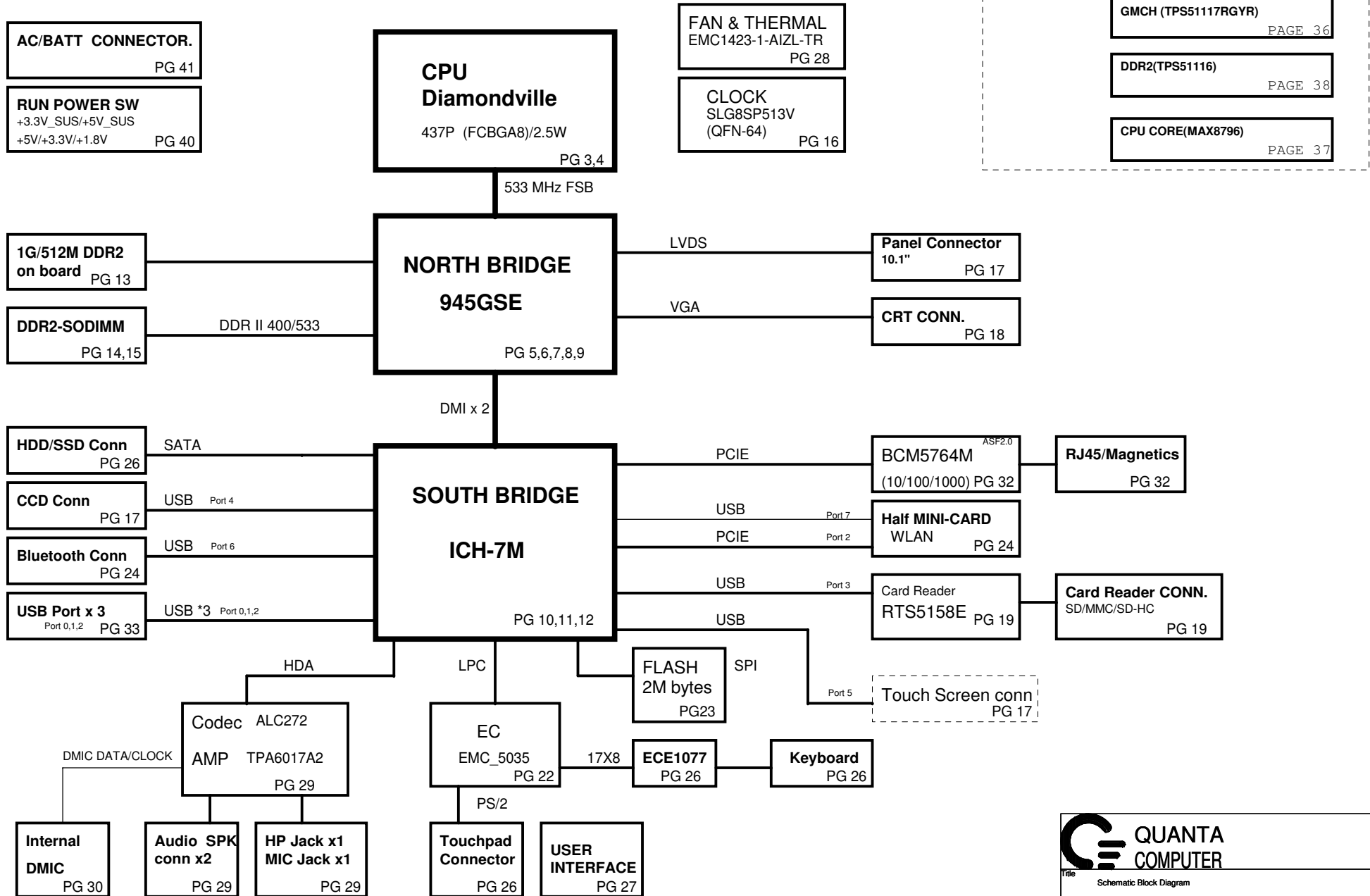

**QUANTA COMPUTER**

Title: Schematic Block Diagram

Size	Document Number	Rev
	ZM1	3A







Date: Tuesday, March 31, 2009 Sheet 1 of 46

Table of Contents

PAGE	DESCRIPTION
1	Schematic Block Diagram
2	Front Page
3-4	Diamondville
5-9	Calistoga-945GSE
10-12	ICH7M
13	On Board Memory support
14-15	DDRII SO-DIMM(200P)
16	Clock Generator
17	LCD Conn.
18	CRT Conn
19	CARD READER/Conn
22	SIO (SMsC5035)
23	FLASH/RTC
24	Mini Card(WLAN)
25	SATA (HDD)
26	TP/KB/ECE1077
27	SWITCH /LED
28	FAN & Thermal
29	Audio CODEC(ALC272)
30	D-MIC
31-32	LAN(BCM5764M)
33	USB
34	System Reset Circuit
35	Battery Charger
36	GMCH_VCCP,1.5V
37	CPU(MAX8796)
38	DDR2_1.8VSUS, 0.9V
39	MAX17020 (+5.5V,+3.3V)
40	RUN Power Switch
41	DCIN,Batt
42	PAD& SCREW
43	EMI CAP
44	SMBUS BLOCK
45	Power Block Dianram
46	Port Mapping

Power States

POWER PLANE	VOLTAGE	PAGE	DESCRIPTION	CONTROL SIGNAL	ACTIVE IN
+PWR_SRC	10V~+19V	17,23,35-38,42	MAIN POWER		S0~S5
+RTC_CELL	+3.0V~+3.3V	10,13,22,23	RTC		S0~S5
+3.3V_ALW	+3.3V	22,23,28,29,34,35,38-40	8051 POWER	ALWON	S0~S5
+5V_ALW	+5V	8,26,38,39,42	LCD/CHARGE POWER	ALWON	S0~S5
+15V_ALW	+15V	39	LARGE POWER	+5V_ALW	S0~S5
+3.3V_LAN	+3.3V	33	LAN POWER	LAN_PWR_ON	
+5V_SUS	+5V	13,29,39	SLP_S5# CTRLD POWER	SUS_ON	
+3.3V_SUS	+3.3V	08,11-13,17,24,29,33,39	SLP_S5# CTRLD POWER	3.3V_SUS_ON	
+1.8V_SUS	+1.8V	06,08,14,36,39	SODIMM POWER	DDR_ON	
+0.9V_DDR_VTT	+0.9V	15,36,39	SODIMM POWER	0.9V_DDR_VTT_ON	
+5V_RUN	+5V	13,18,20,27-31,39	SLP_S3# CTRLD POWER	RUN_ON	
+2.5V_RUN	+2.5V	8	945GMS power	RUN_ON	
+3.3V_RUN	+3.3V	06-08,10-14,16-19,22,,24,25,27,29--31,33,39,42	SLP_S3# CTRLD POWER	3.3V_RUN_ON	
+1.5V_RUN	+1.5V	04,06,08,11,13,24,25	CALISTOGA/ICH8 POWER	1.5V_RUN_ON	
+1.05V_VCCP	+1.05V	03-05,07,08,10,13	CPU/CALISTOGA/ICH8 POWER	1.05V_RUN_ON	
+VCC_CORE	+0.7V~+1.77V	04,37,42	CPU CORE POWER	IMVP_VR_ON	
+LCDVCC	+3.3V	17	LCD Power	LCDVCC_TST_EN & ENVDD	
+5V_HDD	+5V	27	HDD Power	HDDC_EN	
+PBATT	+10V~+17V	35,40	MAIN BATTERY	CHG_PBATT	

GND PLANE	PAGE	DESCRIPTION
 GND_A_CHG	35	
 GND_1.05V	36	
 AGND_DC/DC	38	
 GND_POWER	33	
 AGND_DDR		
 AGND_ISL6260		
 GND	ALL	



**QUANTA  
COMPUTER**

Title: Index & Power Status

Size	Document Number ZM1	Rev 3A
------	------------------------	-----------

Date: Tuesday, March 31, 2009      Sheet 2 of 46

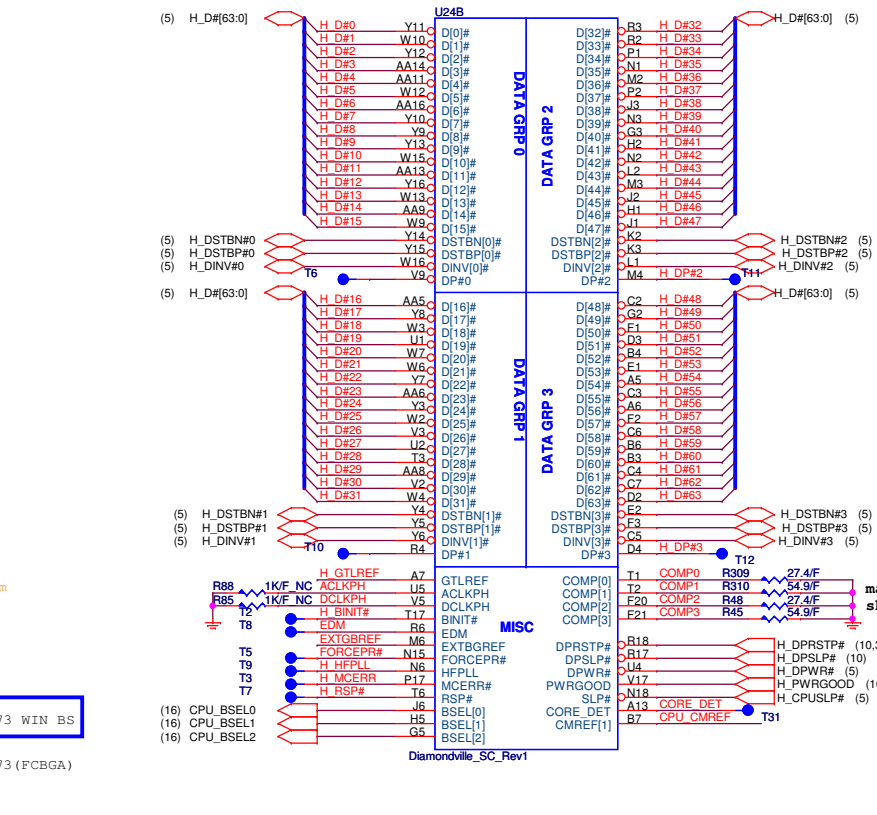
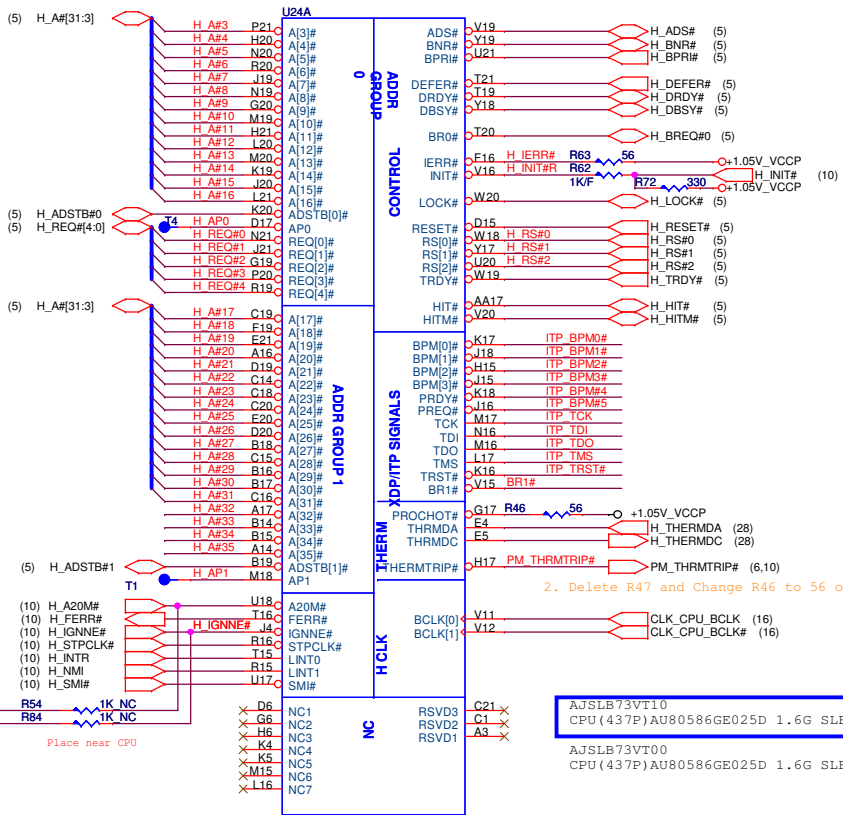

2. Delete R47 and Change R46 to 56 ohm

AJSLB73VF10  
CPU (437P)AU80586GE025D 1.6G SLB73 WIN BS  
AJSLB73VT00  
CPU (437P)AU80586GE025D 1.6G SLB73 (FCBGA)

Diamondville\_SC\_Rev1

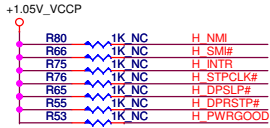

For defensive design reservation only in this initial release

12. NC R90 for Intel proposal

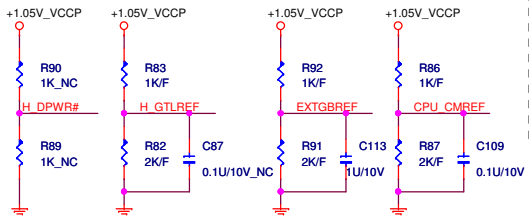

Layout note:  
2o=55ohm, 0.5" max for GTLREF  
2o=55ohm, 0.5" max for EXTGBREF  
2o=55ohm, 0.5" max for GTLREF

Populate ITP700Flex for bringup

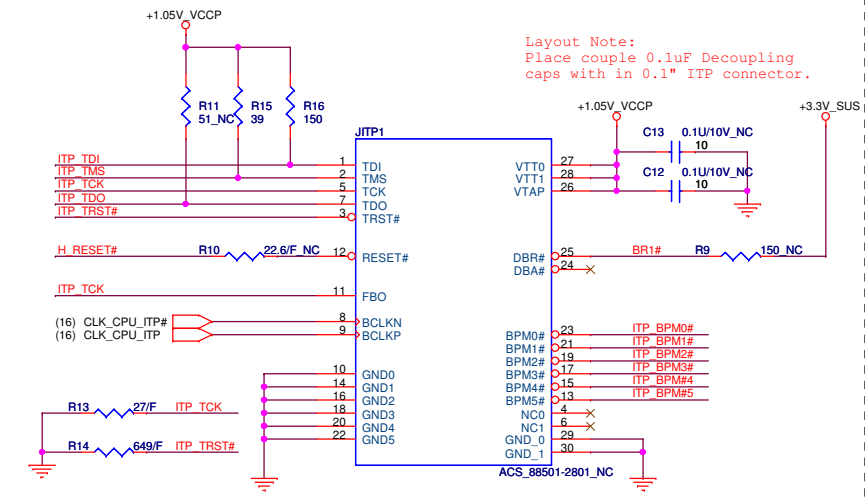

Layout Note:  
Place couple 0.1uF Decoupling caps with in 0.1" ITP connector.

THRMTRIP#

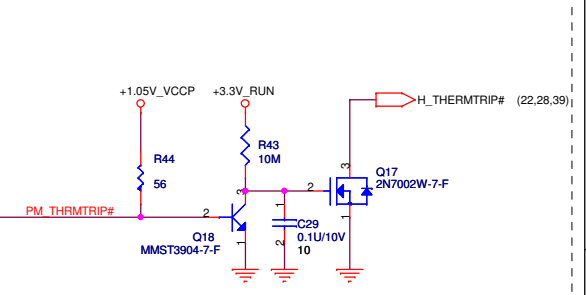

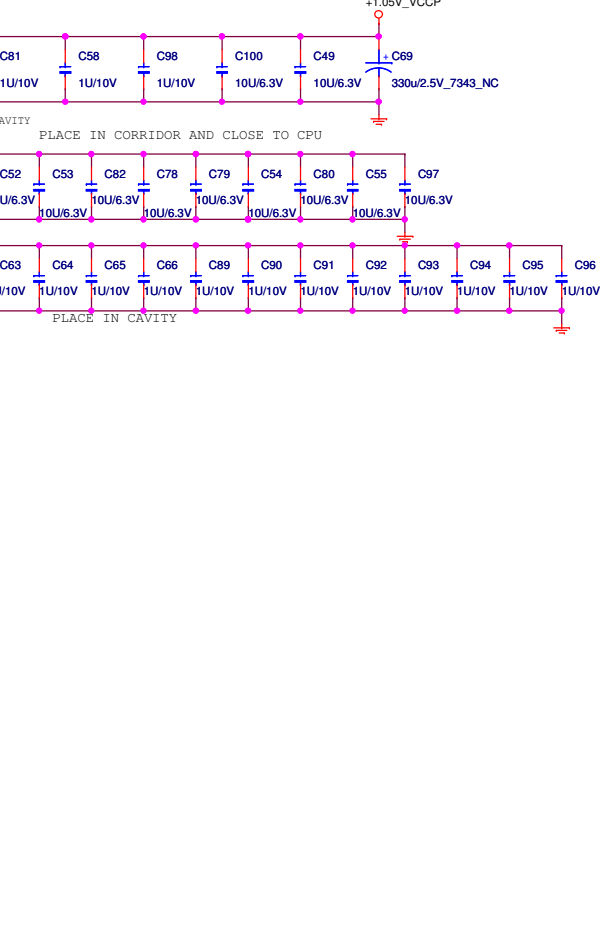
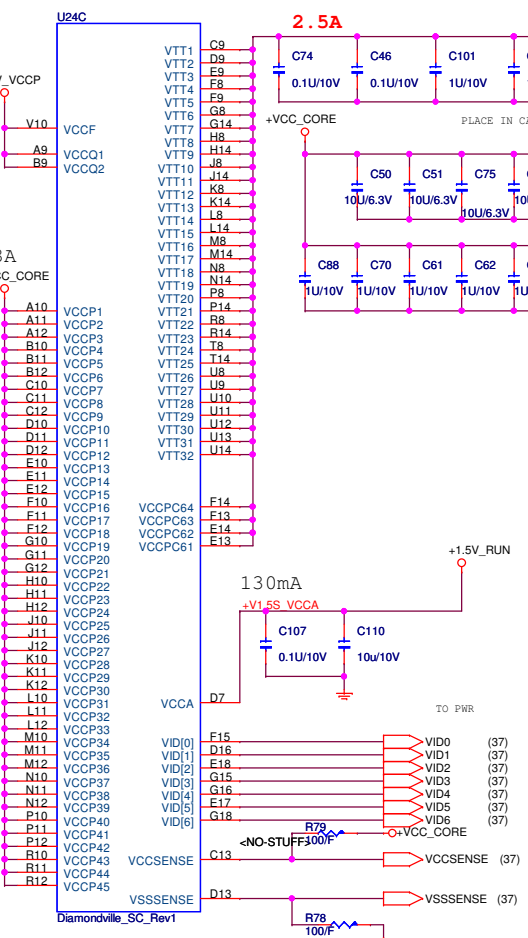
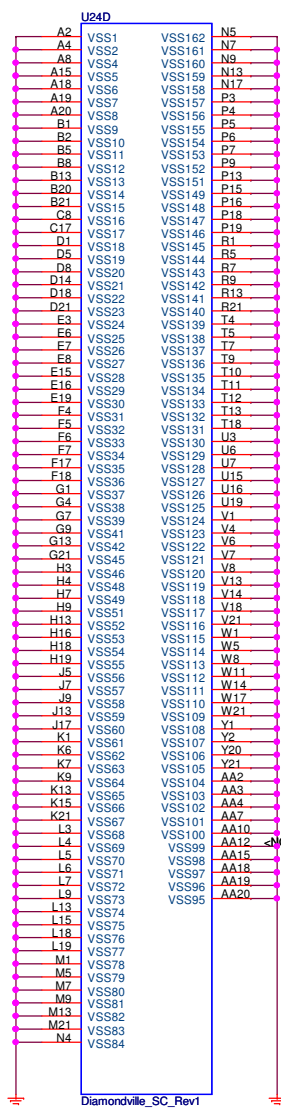

Title		
Processor Diamondville (POWER)		
Size	Document Number	Rev
	ZM1	3A
Date:	Tuesday, March 31, 2009	Sheet 4 of 46

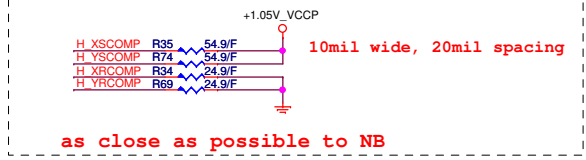
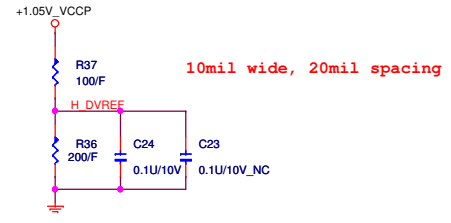
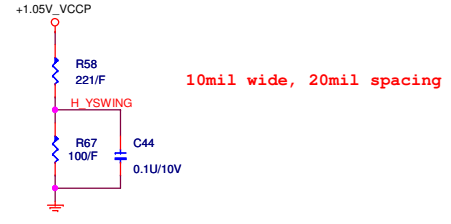
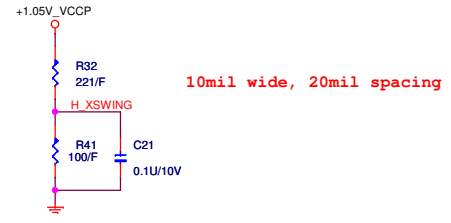
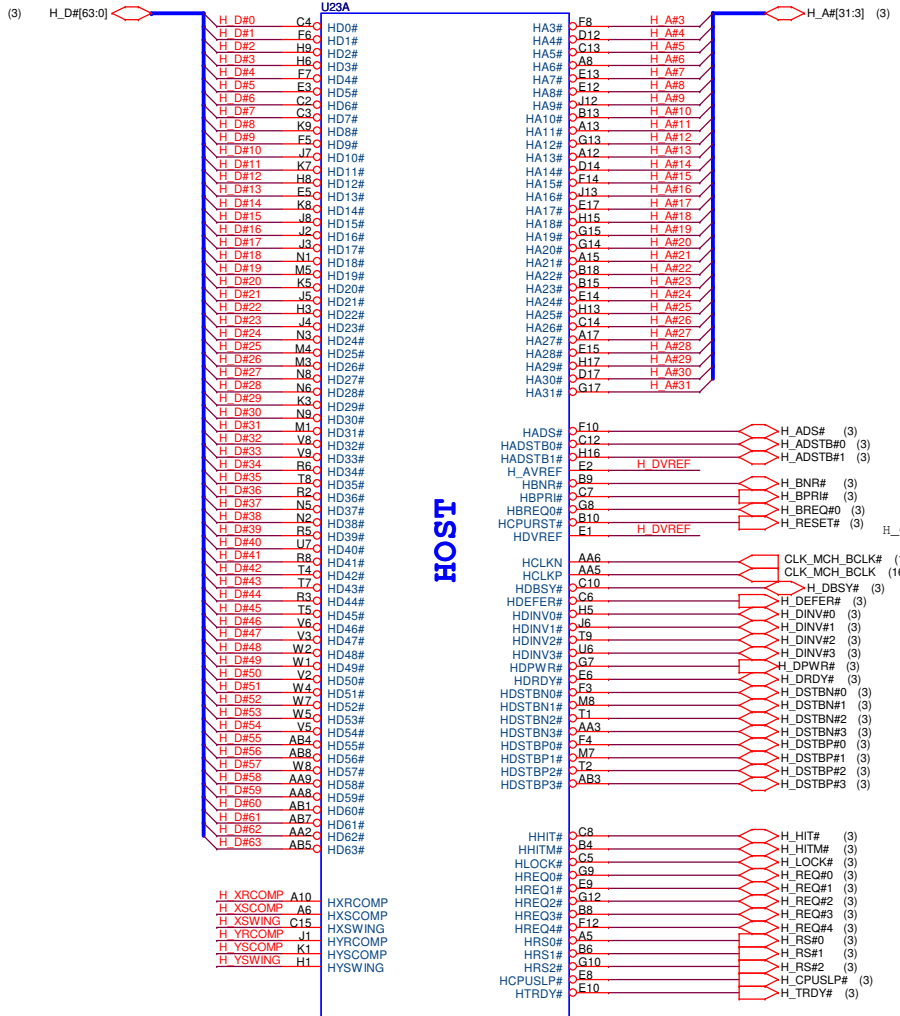

945GSE

AJSLB2R0T05  
IC CTRL(998P)QG82945GSE SLB2R(FCBGA)

AJSLB2R0T11  
IC CTRL(998P)QG82945GSE SLB2R WIN B/S



as close as possible to NB  
 VGA\_BLU -- R (150)  
 VGA\_GRN -- R (150)  
 VGA\_RED -- R (150)

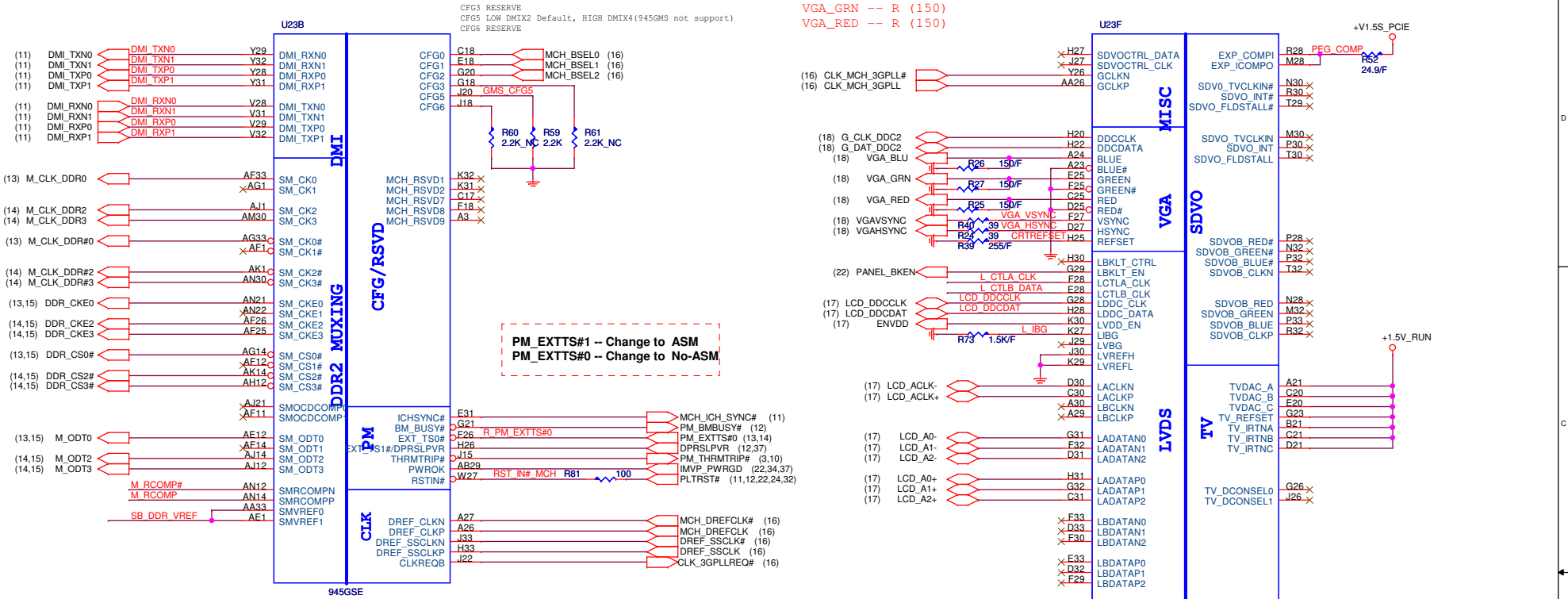

**PM\_EXTTS#1 -- Change to ASM**  
**PM\_EXTTS#0 -- Change to No-ASM**

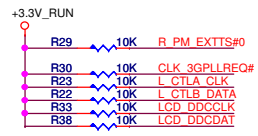
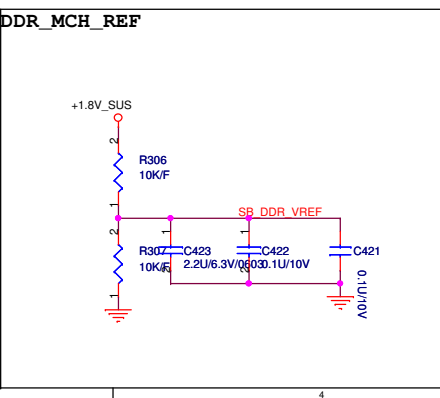
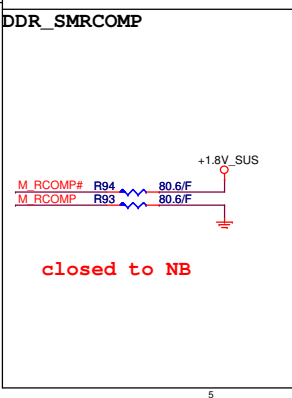

**QUANTA COMPUTER**

Title: 945GMS (VGA,DMI)

Size	Document Number ZM1	Rev 2B
Date:	Tuesday, March 31, 2009	Sheet 6 of 46

(13,14) DDR\_A\_D[0..63]

U23C	U23H
DDR A D0 AC31	T25 VCC_NCTF1
DDR A D1 AB28	R25 VCC_NCTF2
DDR A D2 AE33	P25 VCC_NCTF3
DDR A D3 AF32	N25 VCC_NCTF4
DDR A D4 AC33	M25 VCC_NCTF5
DDR A D5 AB32	N24 VCC_NCTF6
DDR A D6 AB31	M24 VCC_NCTF8
DDR A D7 AE31	Y22 VCC_NCTF9
DDR A D8 AH31	W22 VCC_NCTF10
DDR A D9 AK31	Y22 VCC_NCTF11
DDR A D10 AL28	U22 VCC_NCTF12
DDR A D11 AK27	T22 VCC_NCTF13
DDR A D12 AH30	R22 VCC_NCTF14
DDR A D13 AL32	P22 VCC_NCTF15
DDR A D14 AJ28	N22 VCC_NCTF16
DDR A D15 AJ27	M22 VCC_NCTF17
DDR A D16 AH32	Y21 VCC_NCTF18
DDR A D17 AF31	W21 VCC_NCTF19
DDR A D18 AH27	V21 VCC_NCTF20
DDR A D19 AF28	U21 VCC_NCTF21
DDR A D20 AJ32	T21 VCC_NCTF22
DDR A D21 AG31	R21 VCC_NCTF23
DDR A D22 AG28	P21 VCC_NCTF24
DDR A D23 AG27	N21 VCC_NCTF25
DDR A D24 AN27	M21 VCC_NCTF26
DDR A D25 AM26	Y20 VCC_NCTF27
DDR A D26 AJ26	W20 VCC_NCTF28
DDR A D27 AJ26	V20 VCC_NCTF29
DDR A D28 AL27	U20 VCC_NCTF30
DDR A D29 AN26	T20 VCC_NCTF31
DDR A D30 AH25	R20 VCC_NCTF32
DDR A D31 AG26	P20 VCC_NCTF33
DDR A D32 AM12	N20 VCC_NCTF34
DDR A D33 AL11	M20 VCC_NCTF36
DDR A D34 AH9	Y19 VCC_NCTF37
DDR A D35 AK9	W19 VCC_NCTF38
DDR A D36 AM11	V19 VCC_NCTF39
DDR A D37 AK11	U19 VCC_NCTF40
DDR A D38 AM8	T19 VCC_NCTF41
DDR A D39 AK8	R18 VCC_NCTF42
DDR A D40 AG9	P18 VCC_NCTF43
DDR A D41 AF9	N18 VCC_NCTF44
DDR A D42 AF8	M18 VCC_NCTF45
DDR A D43 AK6	Y17 VCC_NCTF46
DDR A D44 AF7	W17 VCC_NCTF47
DDR A D45 AG11	V17 VCC_NCTF48
DDR A D46 AJ6	U17 VCC_NCTF49
DDR A D47 AH6	T16 VCC_NCTF50
DDR A D48 AN6	R16 VCC_NCTF51
DDR A D49 AM6	P16 VCC_NCTF52
DDR A D50 AK3	N16 VCC_NCTF53
DDR A D51 AL2	M16 VCC_NCTF54
DDR A D52 AM5	Y15 VCC_NCTF55
DDR A D53 AL5	W15 VCC_NCTF56
DDR A D54 AJ3	U15 VCC_NCTF57
DDR A D55 AJ2	T15 VCC_NCTF58
DDR A D56 AG2	R14 VCC_NCTF59
DDR A D57 AF3	P14 VCC_NCTF60
DDR A D58 AE7	N14 VCC_NCTF61
DDR A D59 AF6	M14 VCC_NCTF62
DDR A D60 AH5	Y14 VCC_NCTF63
DDR A D61 AG3	W14 VCC_NCTF64
DDR A D62 AG5	V14 VCC_NCTF66
DDR A D63 AF5	U14 VCC_NCTF66

(14,15) DDR\_B\_CAS# AG19  
 (14,15) DDR\_B\_RAS# AG21  
 (14,15) DDR\_B\_WE# AG20

DDR2 SYSTEM MEMORY

U23C	U23H
SA_BS_0 AK12	DDR_A_BS0 (13,15)
SA_BS_1 AH11	DDR_A_BS1 (13,15)
SA_BS_2 AG17	DDR_A_BS2 (13,15)
SA_DM0 AB30	DDR_A_DM0
SA_DM1 AL31	DDR_A_DM1
SA_DM2 AF30	DDR_A_DM2
SA_DM3 AK26	DDR_A_DM3
SA_DM4 AL9	DDR_A_DM4
SA_DM5 AG7	DDR_A_DM5
SA_DM6 AK5	DDR_A_DM6
SA_DM7 AH3	DDR_A_DM7
SA_DQS0 AC28	DDR_A_DQS0
SA_DQS1 AJ30	DDR_A_DQS1
SA_DQS2 AK33	DDR_A_DQS2
SA_DQS3 AL25	DDR_A_DQS3
SA_DQS4 AN9	DDR_A_DQS4
SA_DQS5 AH8	DDR_A_DQS5
SA_DQS6 AM2	DDR_A_DQS6
SA_DQS7 AE3	DDR_A_DQS7
SA_DQS#0 AC29	DDR_A_DQS#0
SA_DQS#1 AK30	DDR_A_DQS#1
SA_DQS#2 AJ33	DDR_A_DQS#2
SA_DQS#3 AM25	DDR_A_DQS#3
SA_DQS#4 AN8	DDR_A_DQS#4
SA_DQS#5 AJ8	DDR_A_DQS#5
SA_DQS#6 AM3	DDR_A_DQS#6
SA_DQS#7 AE2	DDR_A_DQS#7
SA_MA0 AJ15	DDR_A_MA0
SA_MA1 AM17	DDR_A_MA1
SA_MA2 AM15	DDR_A_MA2
SA_MA3 AH15	DDR_A_MA3
SA_MA4 AK15	DDR_A_MA4
SA_MA5 AN15	DDR_A_MA5
SA_MA6 AJ18	DDR_A_MA6
SA_MA7 AF19	DDR_A_MA7
SA_MA8 AN17	DDR_A_MA8
SA_MA9 AL17	DDR_A_MA9
SA_MA10 AG16	DDR_A_MA10
SA_MA11 AL18	DDR_A_MA11
SA_MA12 AG18	DDR_A_MA12
SA_MA13 AL14	DDR_A_MA13
SA_CAS# CAJ17	DDR_A_CAS# (13,15)
SA_RAS# CAK18	DDR_A_RAS# (13,15)
SA_RCVENIN# CAN28	TP SA RCVENIN#
SA_RCVENOUT# CAM28	TP SA RCVENOUT#
SA_WEB CAH17	DDR_A_WE# (13,15)
SB_BS_0 AH21	DDR_B_BS0 (14,15)
SB_BS_1 AJ20	DDR_B_BS1 (14,15)
SB_BS_2 AE27	DDR_B_BS2 (14,15)
SB_MA0 AN20	DDR_B_MA0
SB_MA1 AL21	DDR_B_MA1
SB_MA2 AK21	DDR_B_MA2
SB_MA3 AK22	DDR_B_MA3
SB_MA4 AL22	DDR_B_MA4
SB_MA5 AH22	DDR_B_MA5
SB_MA6 AG22	DDR_B_MA6
SB_MA7 AF21	DDR_B_MA7
SB_MA8 AM21	DDR_B_MA8
SB_MA9 AE21	DDR_B_MA9
SB_MA10 AL20	DDR_B_MA10
SB_MA11 AE22	DDR_B_MA11
SB_MA12 AE26	DDR_B_MA12
SB_MA13 AE20	DDR_B_MA13

945GSE

+1.05V\_VCCP

U23H	U23H
T25 VCC_NCTF1	VCCAUX_NCTF1
R25 VCC_NCTF2	VCCAUX_NCTF2
P25 VCC_NCTF3	VCCAUX_NCTF3
N25 VCC_NCTF4	VCCAUX_NCTF4
M25 VCC_NCTF5	VCCAUX_NCTF5
N24 VCC_NCTF6	VCCAUX_NCTF6
M24 VCC_NCTF8	VCCAUX_NCTF8
Y22 VCC_NCTF9	VCCAUX_NCTF9
W22 VCC_NCTF10	VCCAUX_NCTF10
Y22 VCC_NCTF11	VCCAUX_NCTF11
U22 VCC_NCTF12	VCCAUX_NCTF12
T22 VCC_NCTF13	VCCAUX_NCTF13
R22 VCC_NCTF14	VCCAUX_NCTF14
P22 VCC_NCTF15	VCCAUX_NCTF15
N22 VCC_NCTF16	VCCAUX_NCTF16
M22 VCC_NCTF17	VCCAUX_NCTF17
Y21 VCC_NCTF18	VCCAUX_NCTF18
W21 VCC_NCTF19	VCCAUX_NCTF19
V21 VCC_NCTF20	VCCAUX_NCTF20
U21 VCC_NCTF21	VCCAUX_NCTF21
T21 VCC_NCTF22	VCCAUX_NCTF22
R21 VCC_NCTF23	VCCAUX_NCTF23
P21 VCC_NCTF24	VCCAUX_NCTF24
N21 VCC_NCTF25	VCCAUX_NCTF25
M21 VCC_NCTF26	VCCAUX_NCTF26
Y20 VCC_NCTF27	VCCAUX_NCTF27
W20 VCC_NCTF28	VCCAUX_NCTF28
V20 VCC_NCTF29	VCCAUX_NCTF29
U20 VCC_NCTF30	VCCAUX_NCTF30
T20 VCC_NCTF31	VCCAUX_NCTF31
R20 VCC_NCTF32	VCCAUX_NCTF32
P20 VCC_NCTF33	VCCAUX_NCTF33
N20 VCC_NCTF34	VCCAUX_NCTF34
M20 VCC_NCTF36	VCCAUX_NCTF36
Y19 VCC_NCTF37	VCCAUX_NCTF37
W19 VCC_NCTF38	VCCAUX_NCTF38
V19 VCC_NCTF39	VSS_NCTF1
U19 VCC_NCTF40	VSS_NCTF2
T19 VCC_NCTF41	VSS_NCTF3
R18 VCC_NCTF42	VSS_NCTF4
P18 VCC_NCTF43	VSS_NCTF5
N18 VCC_NCTF44	VSS_NCTF6
M18 VCC_NCTF45	VSS_NCTF7
Y17 VCC_NCTF46	VSS_NCTF8
W17 VCC_NCTF47	VSS_NCTF9
V17 VCC_NCTF48	VSS_NCTF10
U17 VCC_NCTF49	VSS_NCTF11
T16 VCC_NCTF50	VSS_NCTF12
R16 VCC_NCTF51	VSS_NCTF13
P16 VCC_NCTF52	VSS_NCTF14
N16 VCC_NCTF53	VSS_NCTF15
M16 VCC_NCTF54	VSS_NCTF16
Y15 VCC_NCTF55	VSS_NCTF17
W15 VCC_NCTF56	VSS_NCTF18
U15 VCC_NCTF57	VSS_NCTF19
T15 VCC_NCTF58	
R14 VCC_NCTF59	
P14 VCC_NCTF60	
N14 VCC_NCTF61	
M14 VCC_NCTF62	
Y14 VCC_NCTF63	
W14 VCC_NCTF64	
V14 VCC_NCTF66	
U14 VCC_NCTF66	
T10 VTT_NCTF1	
R10 VTT_NCTF2	
P10 VTT_NCTF3	
N10 VTT_NCTF4	
L10 VTT_NCTF5	
D1 VTT_NCTF6	
M10 MCH_RSVD3	
A18 MCH_RSVD4	
AB10 MCH_RSVD5	
AA10 MCH_RSVD6	

NCTF

945GSE

+1.5V\_RUN

U23H	U23H
AD25 VCCAUX_NCTF1	
AC25 VCCAUX_NCTF2	
AB25 VCCAUX_NCTF3	
AD24 VCCAUX_NCTF4	
AC24 VCCAUX_NCTF5	
AD22 VCCAUX_NCTF6	
AD21 VCCAUX_NCTF7	
AD20 VCCAUX_NCTF8	
AD19 VCCAUX_NCTF9	
AD18 VCCAUX_NCTF10	
AD17 VCCAUX_NCTF11	
AD16 VCCAUX_NCTF12	
AD15 VCCAUX_NCTF13	
AD14 VCCAUX_NCTF14	
K14 VCCAUX_NCTF15	
AD13 VCCAUX_NCTF16	
Y13 VCCAUX_NCTF17	
W13 VCCAUX_NCTF18	
V13 VCCAUX_NCTF19	
U13 VCCAUX_NCTF20	
T13 VCCAUX_NCTF21	
R13 VCCAUX_NCTF22	
P13 VCCAUX_NCTF23	
N13 VCCAUX_NCTF24	
M13 VCCAUX_NCTF25	
AD12 VCCAUX_NCTF26	
Y12 VCCAUX_NCTF27	
W12 VCCAUX_NCTF28	
V12 VCCAUX_NCTF29	
U12 VCCAUX_NCTF30	
T12 VCCAUX_NCTF31	
R12 VCCAUX_NCTF32	
P12 VCCAUX_NCTF33	
N12 VCCAUX_NCTF34	
M12 VCCAUX_NCTF36	
AD11 VCCAUX_NCTF37	
AD10 VCCAUX_NCTF38	
K10 VSS_NCTF1	
AN33 VSS_NCTF2	
AA25 VSS_NCTF3	
V25 VSS_NCTF4	
U25 VSS_NCTF5	
AA22 VSS_NCTF6	
AA21 VSS_NCTF7	
AA20 VSS_NCTF8	
AA19 VSS_NCTF9	
AA18 VSS_NCTF10	
AA17 VSS_NCTF11	
AA16 VSS_NCTF12	
AA15 VSS_NCTF13	
AA14 VSS_NCTF14	
AA13 VSS_NCTF15	
A4 VSS_NCTF16	
A3 VSS_NCTF17	
B2 VSS_NCTF18	
AN1 VSS_NCTF19	
C1 VSS_NCTF19	



Title		945GMS (DDR2)
Size	Document Number	Rev
	ZM1	3A
Date:	Tuesday, March 31, 2009	Sheet 7 of 46

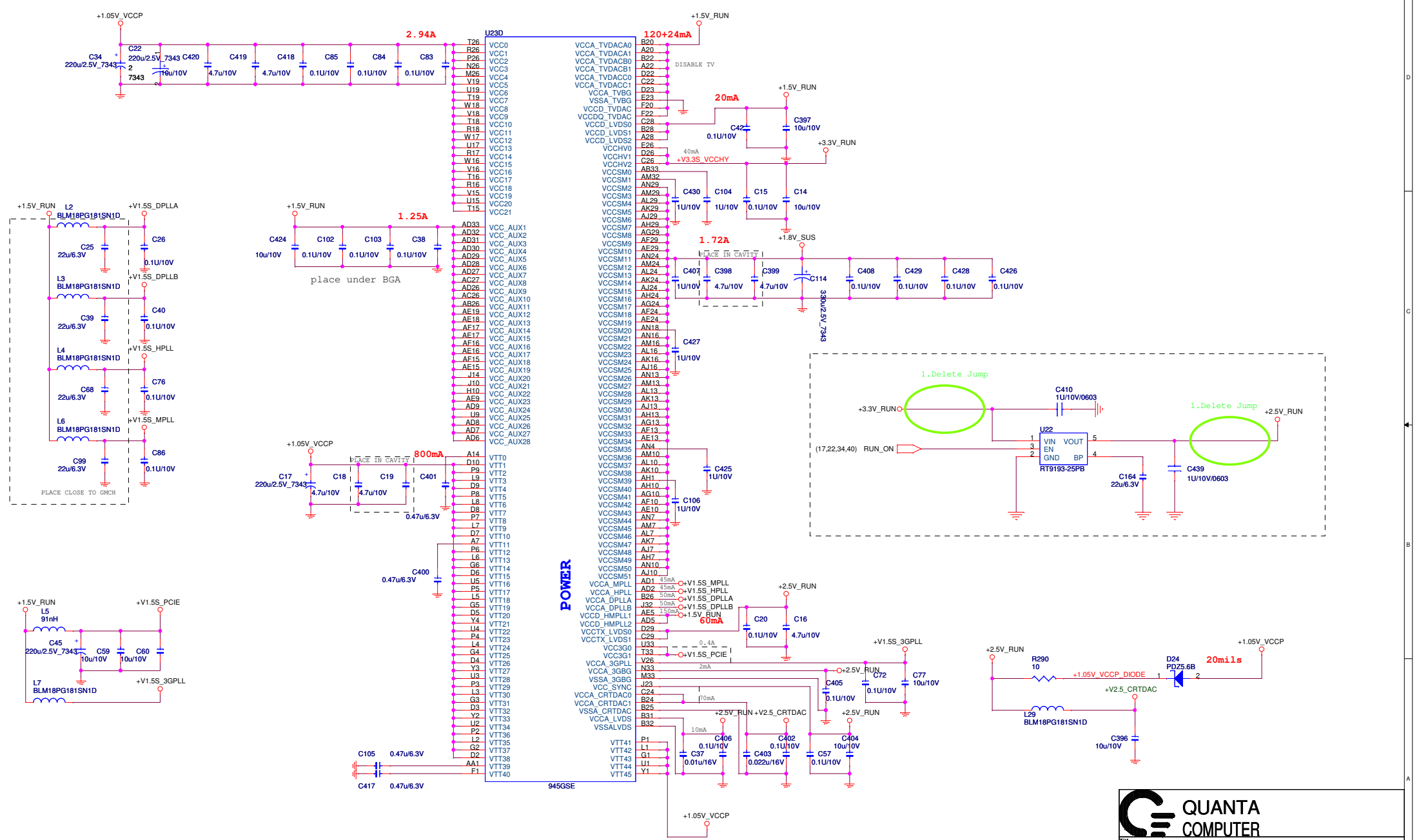

**POWER**

**QUANTA COMPUTER**

Title: 945GMS (POWER)

Size	Document Number	Rev
	ZM1	3A

Date: Tuesday, March 31, 2009 Sheet 8 of 46



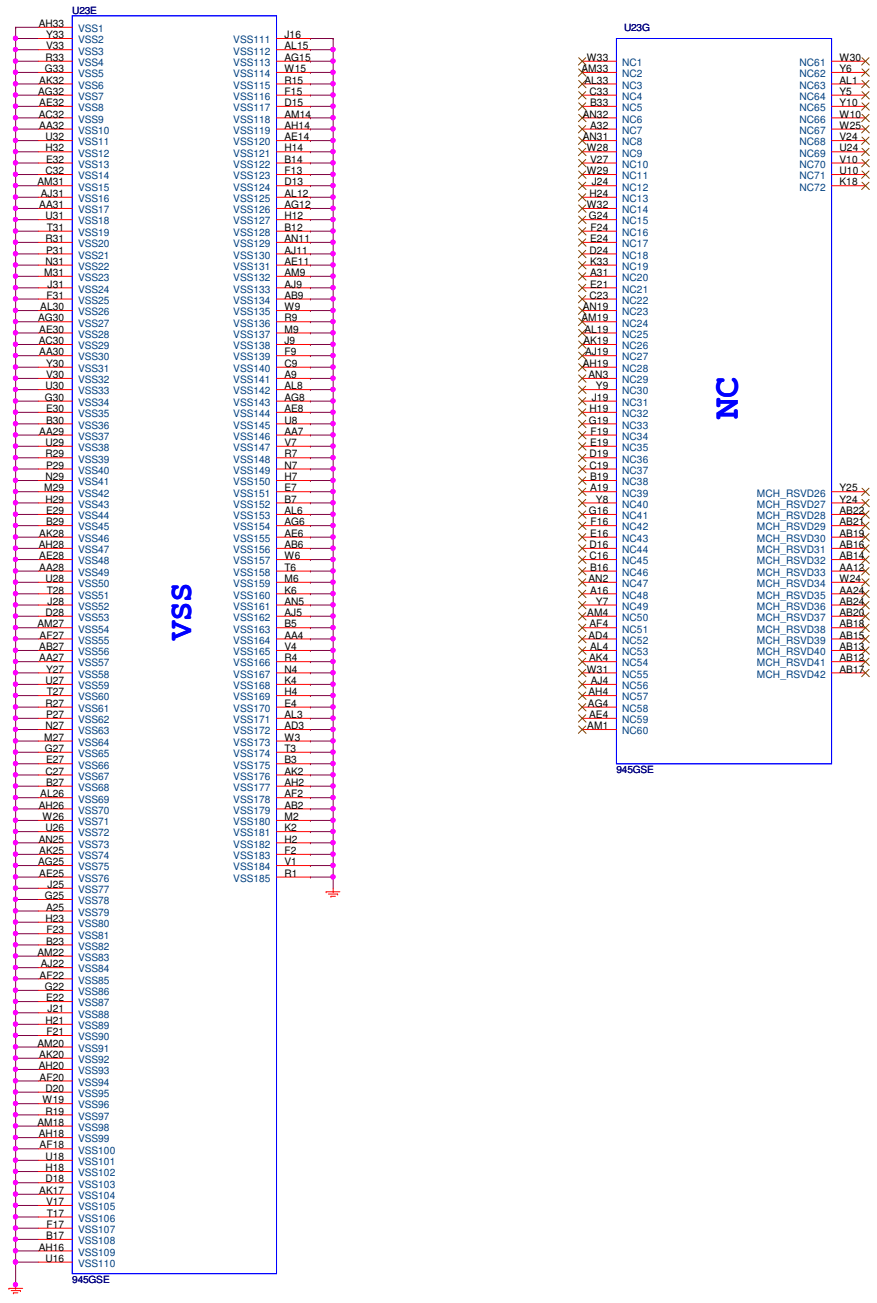

VSS

NC



# RTC

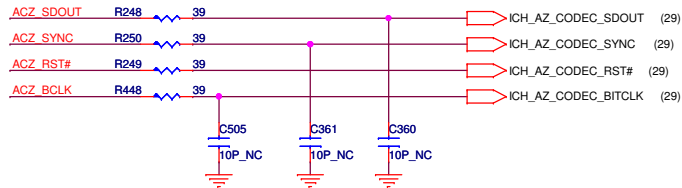
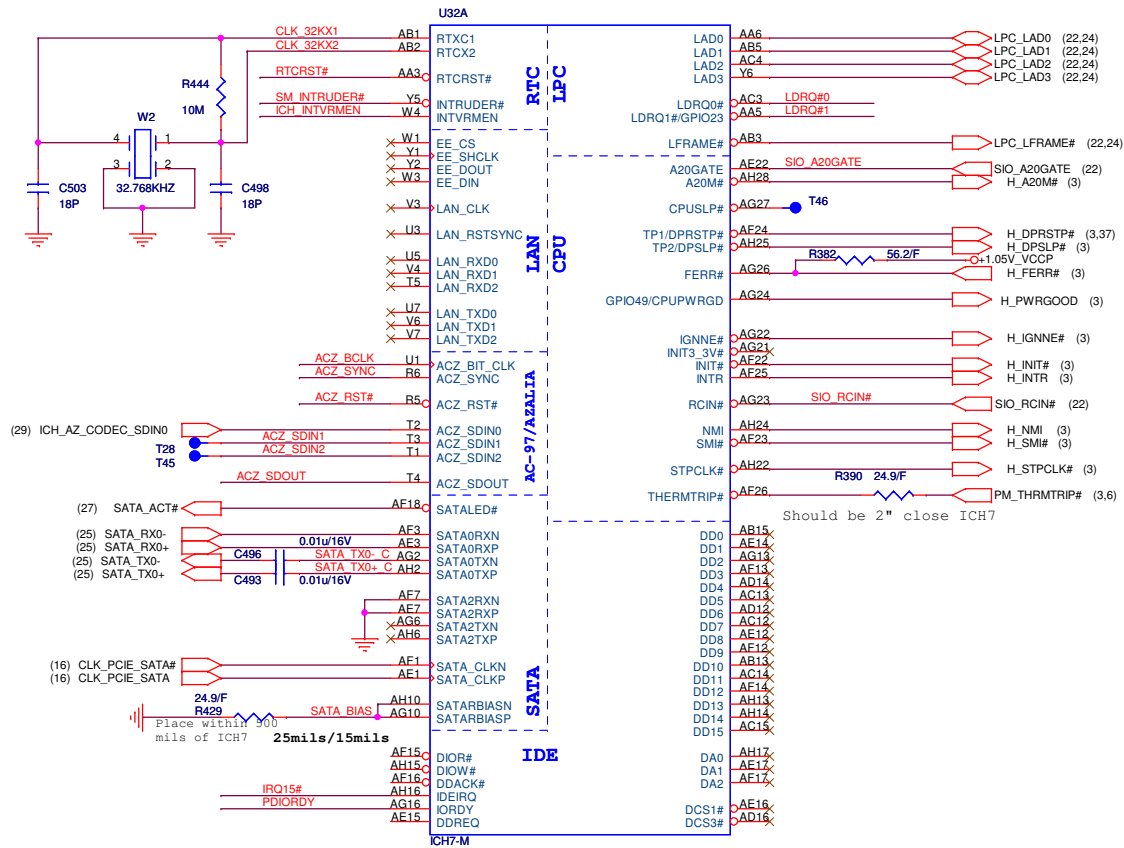
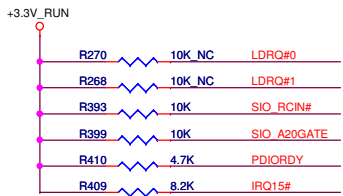
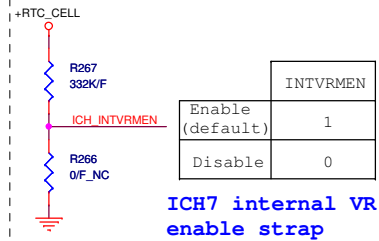
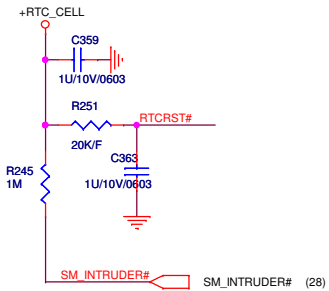

Please all series terms close to ICH7 except for SDIN input lines.

AJSL8YB0T47  
IC (652P) NH82801GBM(ICH7M) BGA WIN B/S

AJSL8YB0T12  
IC (652P) NH82801GBM(ICH7M) BGA



MiniWLAN  
(24) PCIE\_RX2-  
(24) PCIE\_RX2+  
(24) PCIE\_TX2-  
(24) PCIE\_TX2+

Place TX DC blocking caps close ICH7M

LAN  
(32) PCIE\_RX6+/GLAN\_RX-  
(32) PCIE\_RX6+/GLAN\_RX+  
(32) PCIE\_TX6+/GLAN\_TX-  
(32) PCIE\_TX6+/GLAN\_TX+

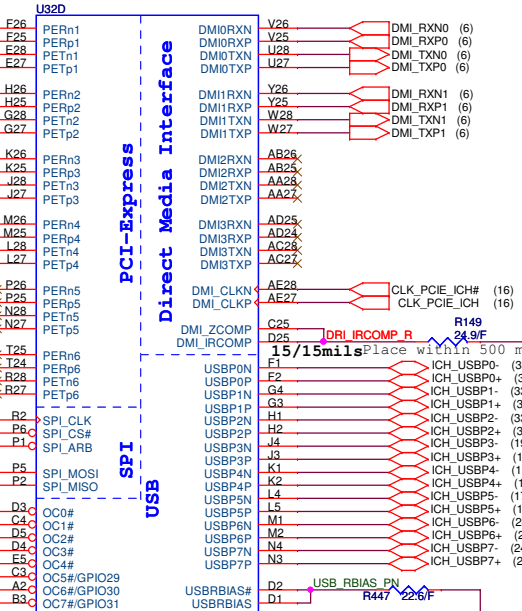
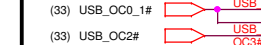
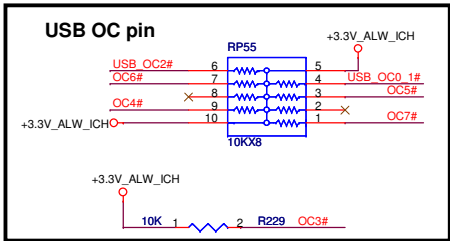
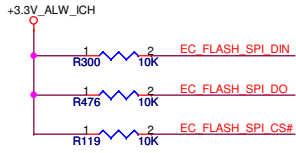

Place within 500 mils of ICH7

Right side top  
Right side bottom  
Left side  
Card Reader  
Camera  
Touch Screen  
Bluetooth  
WLAN

Place within 500 mils of ICH7

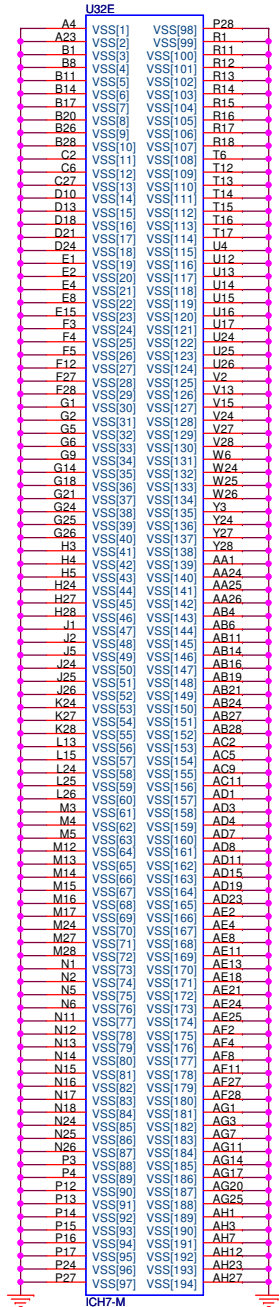

Pull-UP resistor

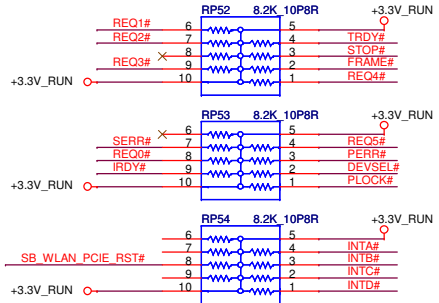

Boot BIOS select  
GNT5, 4  
01: SPI  
10: PCI  
11: LPC (Default)

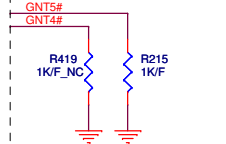

GNT3# A16 SWAP OVERRIDE  
Enable -- R375 Pop  
Disable -- R375 De-Pop

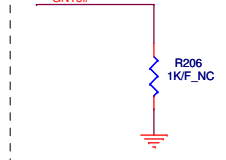

Platform Reset

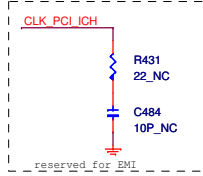
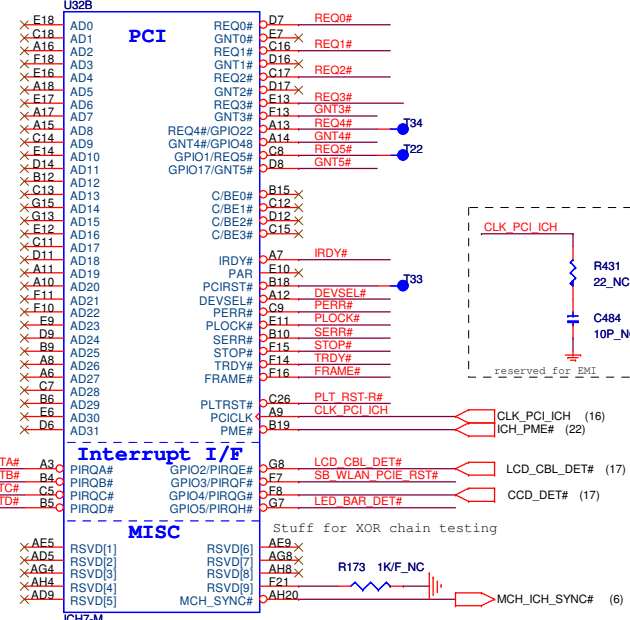
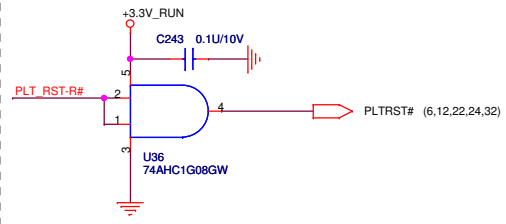

**QUANTA COMPUTER**

Title: ICH7-M (USB & DMI & PCIE & PCI)

Size	Document Number ZM1	Rev	3A
------	---------------------	-----	----

Date: Tuesday, March 31, 2009 Sheet 11 of 46

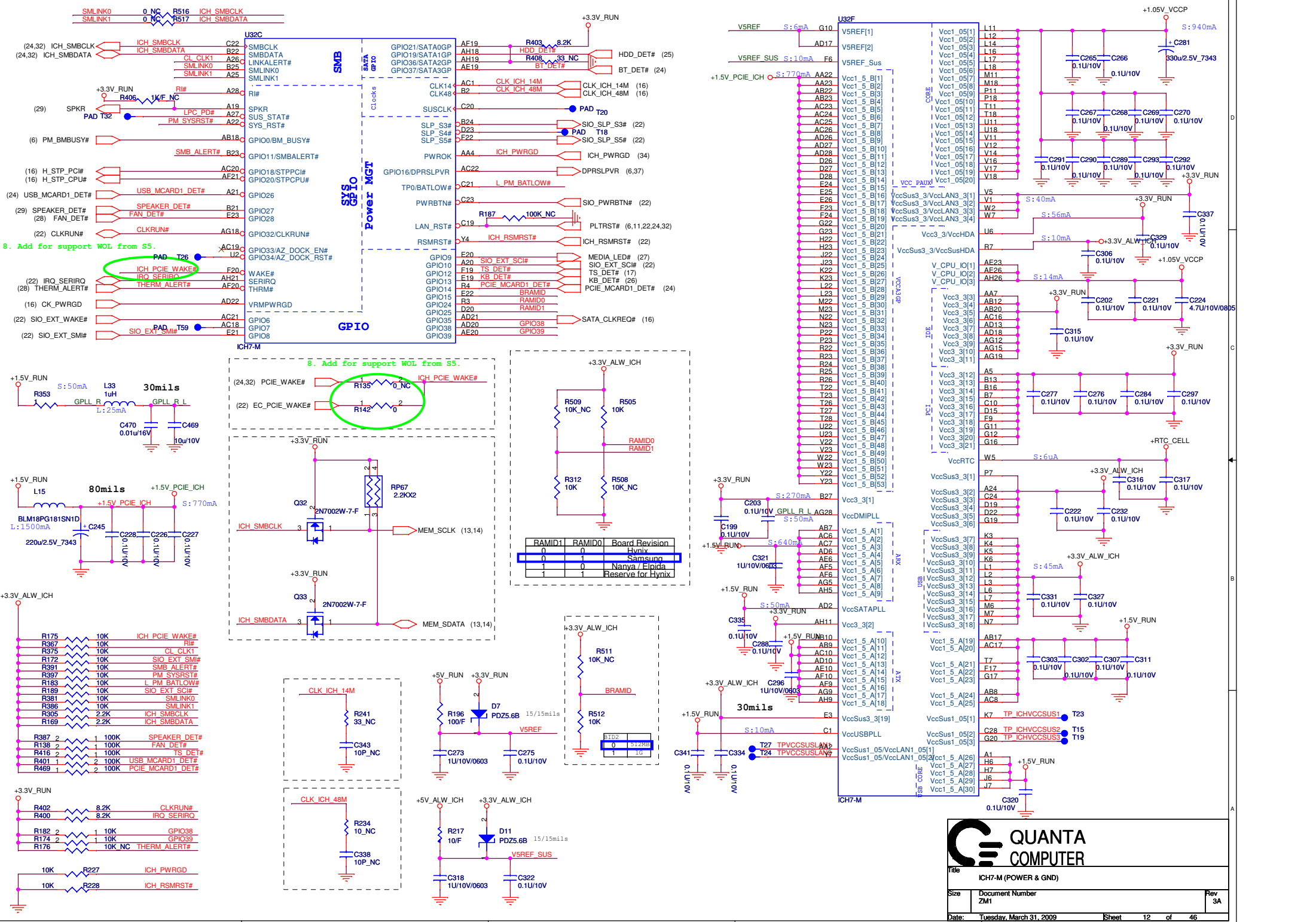

8. Add for support WOL from S5.

8. Add for support WOL from S5.

- R175 10K ICH PCIE WAKE#
- R367 10K RI#
- R375 10K CL CLK1
- R172 10K SIO\_EXT\_SMI#
- R397 10K SMB\_ALERT#
- R397 10K PM\_SYSRST#
- R183 10K L\_PM\_BATLOW#
- R189 10K SIO\_EXT\_SCI#
- R381 10K SMLINK0
- R386 10K SMLINK1
- R305 2.2K ICH SMBCLK
- R169 2.2K ICH SMBDATA
- R387 2 100K SPEAKER\_DET#
- R138 2 100K FAN\_DET#
- R416 2 100K TS\_DET#
- R401 1 2 100K USB\_MCARD1\_DET#
- R469 1 2 100K PCIE\_MCARD1\_DET#

- R402 8.2K CLKRUN#
- R400 8.2K IRO\_SERIRO
- R182 2 10K GPIO38
- R174 2 10K GPIO39
- R176 10K NC THERM\_ALERT#
- R227 10K ICH\_PWRGD
- R228 10K ICH\_RSMRST#

RAMID0	RAMID1	Board Revision
0	0	Hynix
1	0	Samsung
1	1	Nanya / Elpida
1	1	Reserve for Hynix

BTID2	BTID3
0	0
1	1G



(7.14) DDR\_A\_DQS[0..7]  
(7.14) DDR\_A\_DQS[8..15]

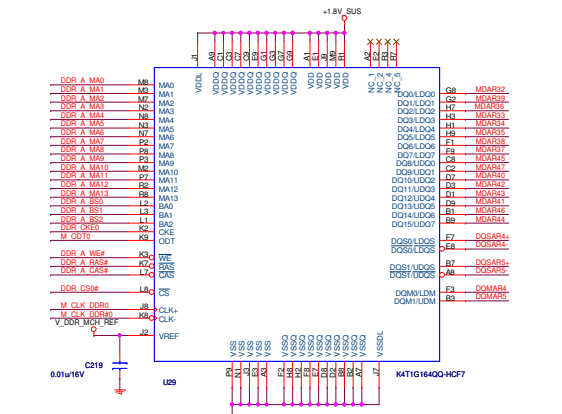
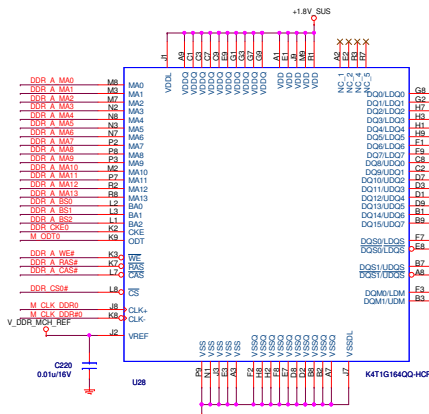
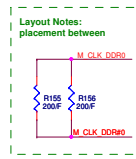
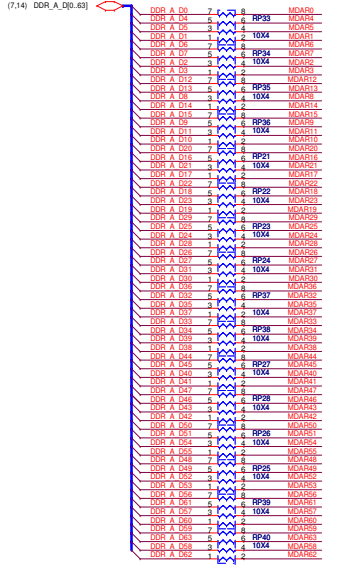
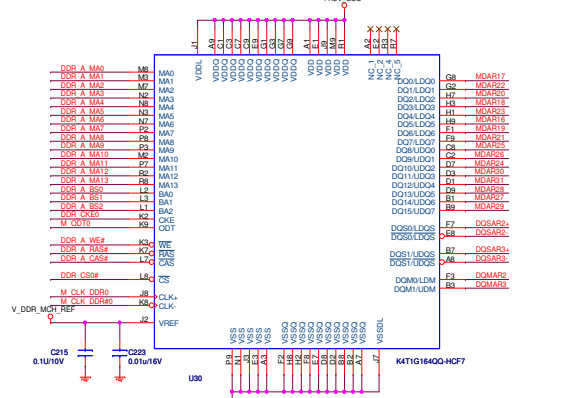
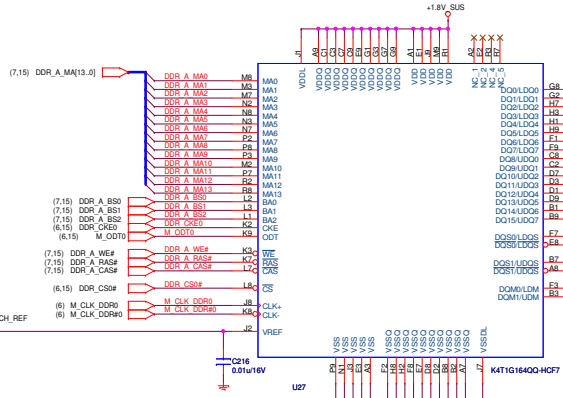
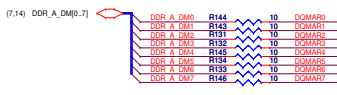
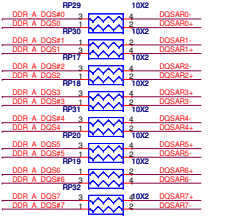

DRAM-Hynix-512MB  
AKD5LGR-TW13  
IC SDRAM(84P) HY5PS1G1631CFP-S6 WIN B/S

DRAM-Samsung-512MB  
AKD5LG-T503  
IC SDRAM(84P) K4T1G1640Q-HCF7(FBGA)

**AKD5LG-TF00**  
IC SDRAM(84P) K4T1G1640Q-HCF7 WIN B/S

AKD5LG-TF01  
IC SDRAM(84P) NT5TU64M16DG-AC(BGA)

AKD5LG-TF01  
IC SDRAM(84P) NT5TU64M16DG-AC WIN B/S

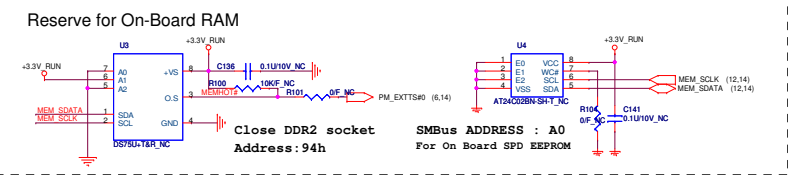
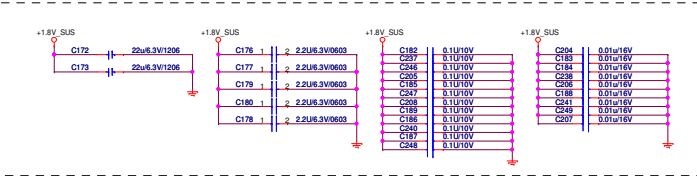

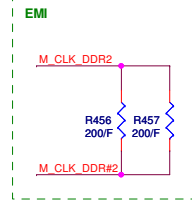
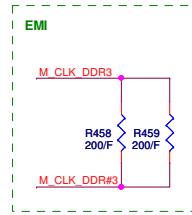
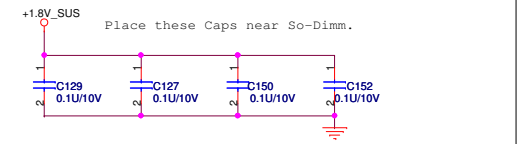
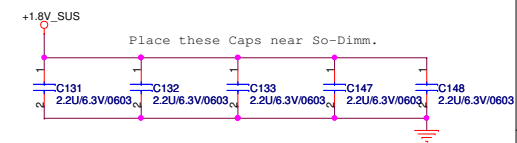
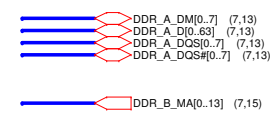
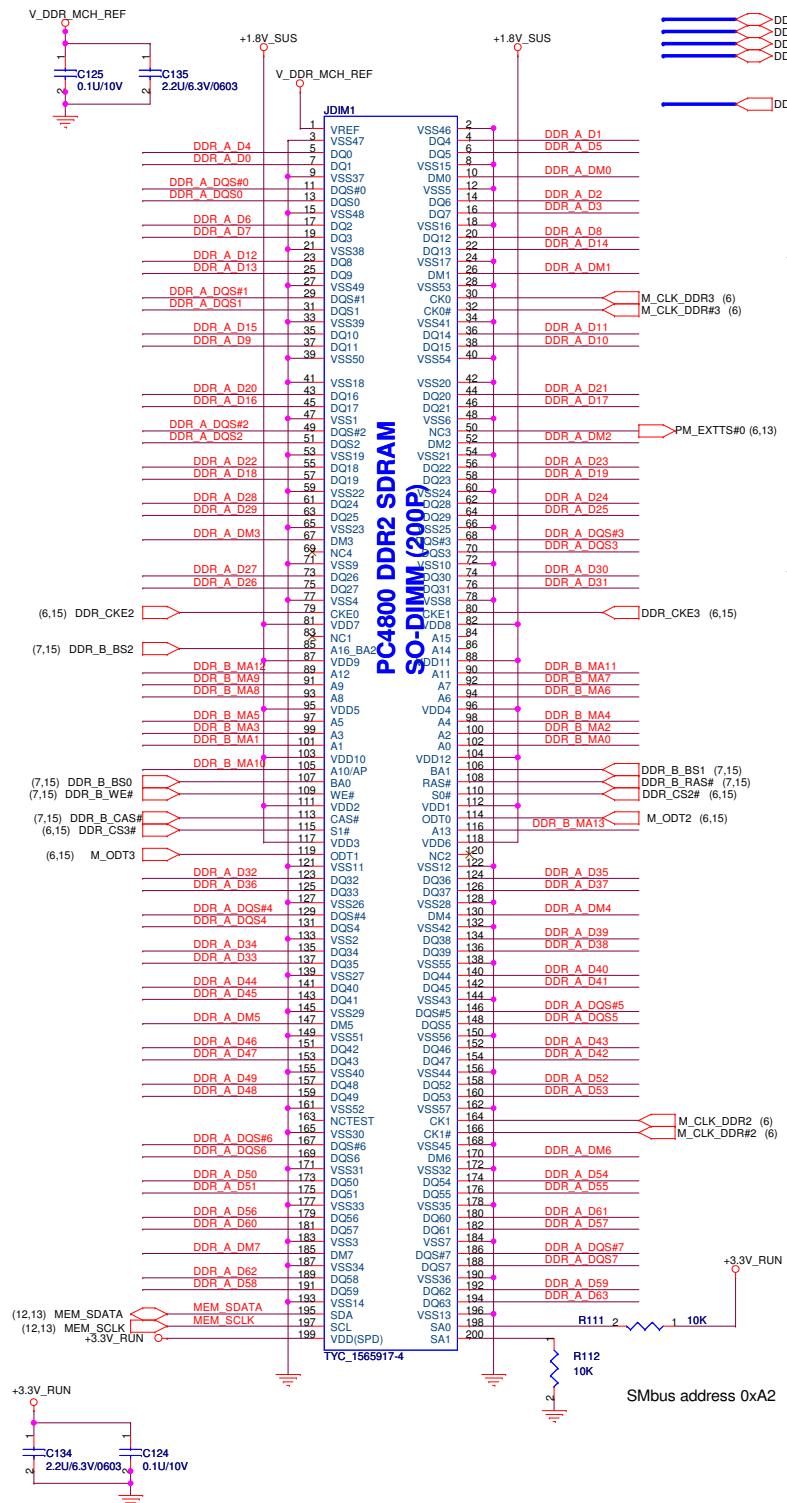

**QUANTA COMPUTER**

Title: System DRAM Expansion (200P-DDR\_SODIMM)

Size	Document Number	Rev
	ZM1	3A

Date: Tuesday, March 31, 2009 Sheet 14 of 46

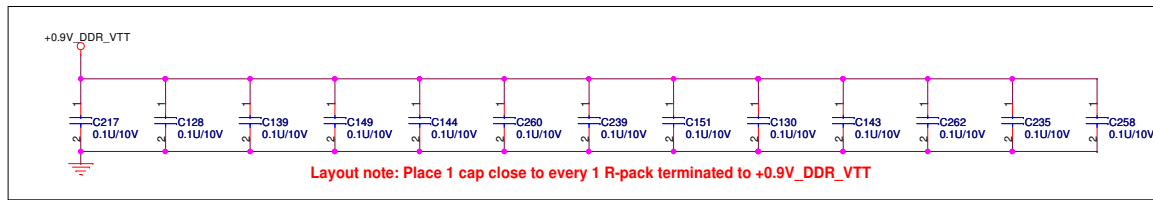

**Layout Note:**  
Place one cap close to every 2 pullup resistors terminated to +0.9V\_DDR\_VTT

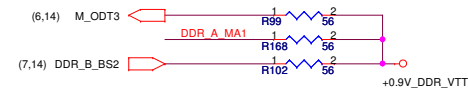
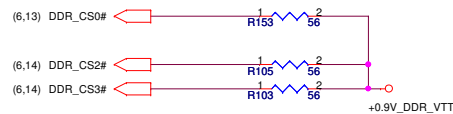
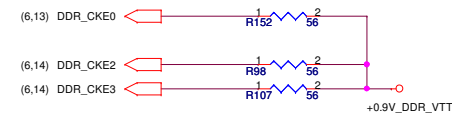
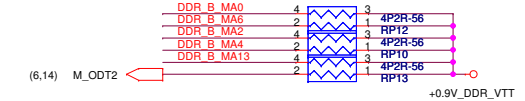
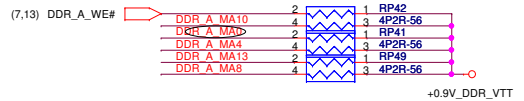
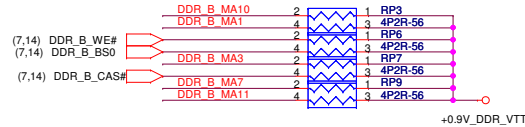
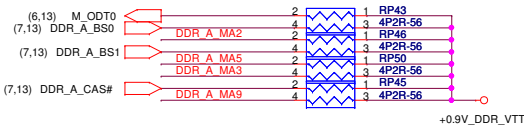
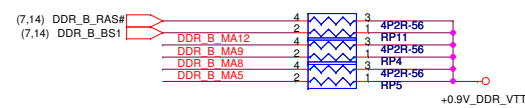
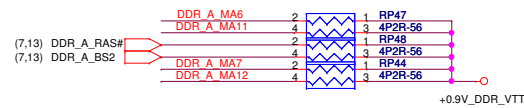

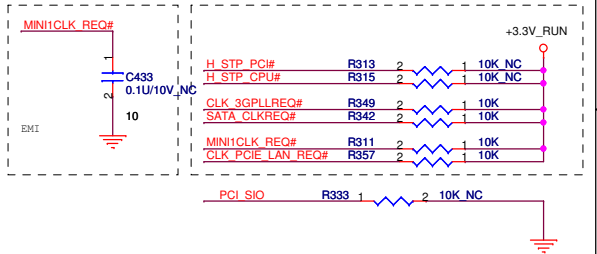
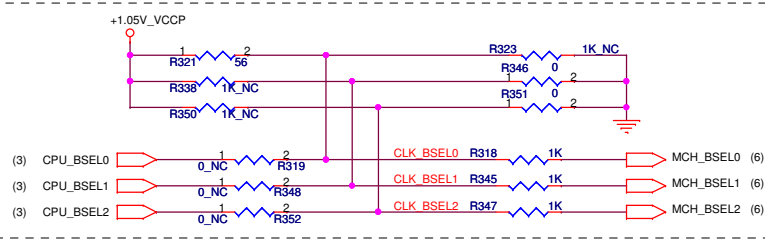
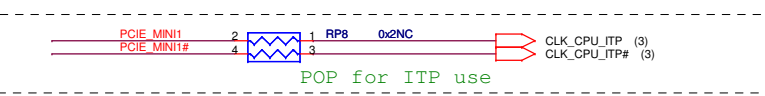
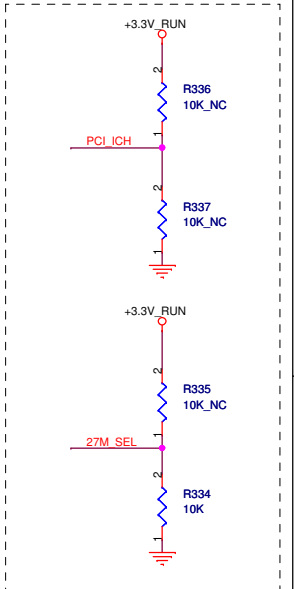
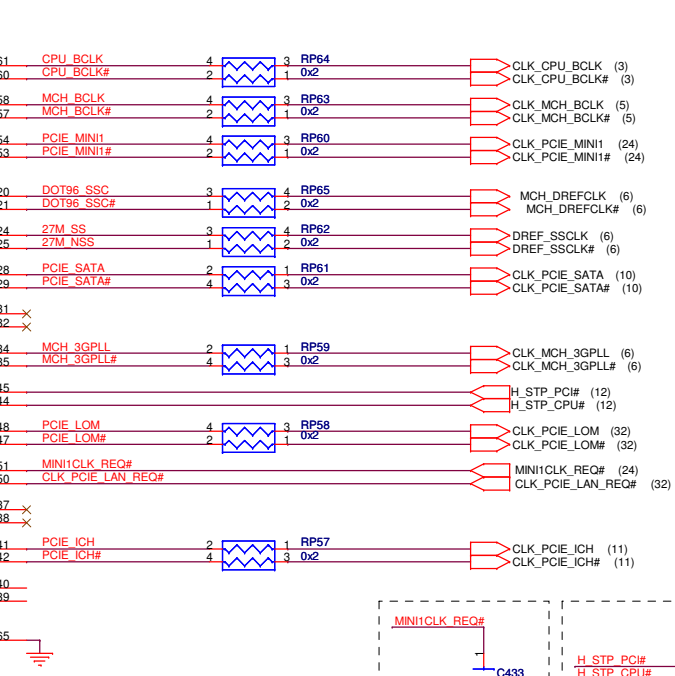
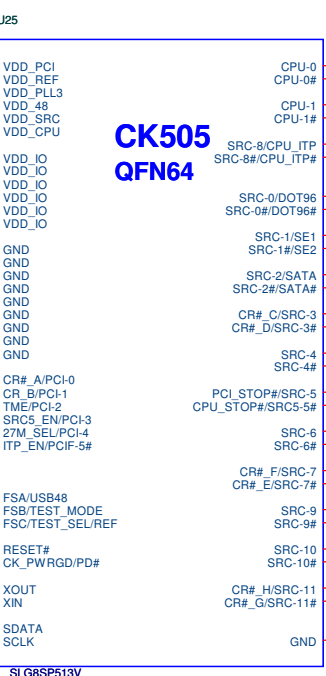
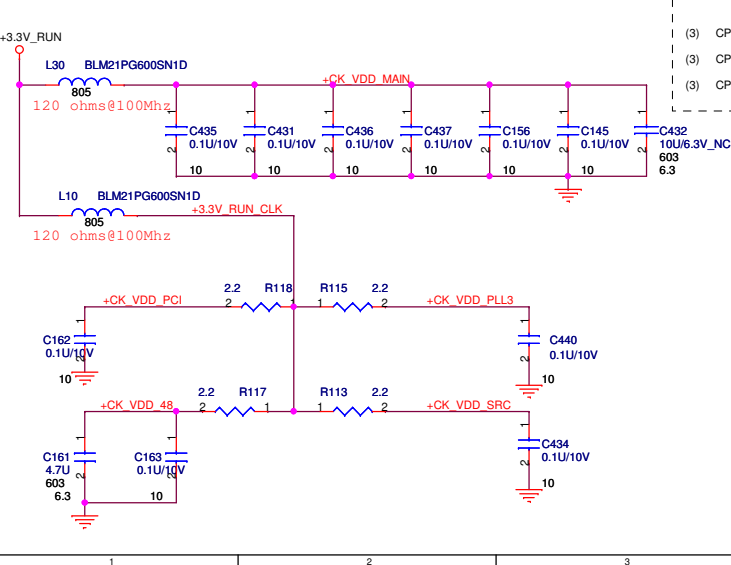
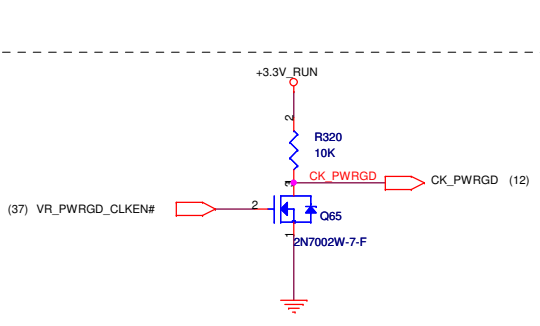
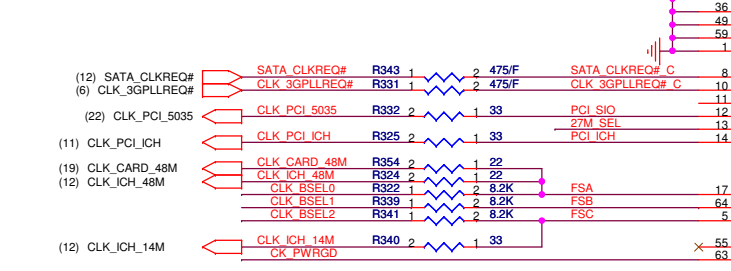
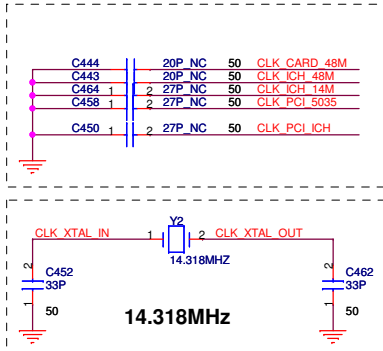

FSC	FSB	FSA	CPU	SRC	PCI
1	0	1	100	100	33
0	0	1	133	100	33
0	1	1	166	100	33
0	1	0	200	100	33
0	0	0	266	100	33
1	0	0	333	100	33
1	1	0	400	100	33
1	1	1	RSVD	100	33

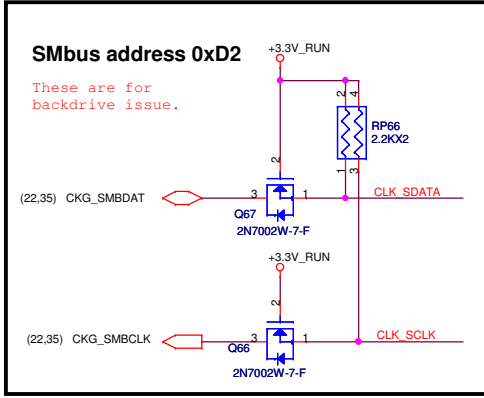

**27M\_SEL**

27M_SEL (PIN13)	PIN20	PIN21	PIN24	PIN25
0=UMA	DOT96T	DOT96C	96/100M_T	96/100M_C
1 = Disc. GRFX down	SRCT0	SRCC0	27Mout	27MSSout

**QUANTA COMPUTER**

File: CLOCK GENERATOR

Size: Document Number ZM1 Rev 3A

Date: Tuesday, March 31, 2009 Sheet 16 of 46



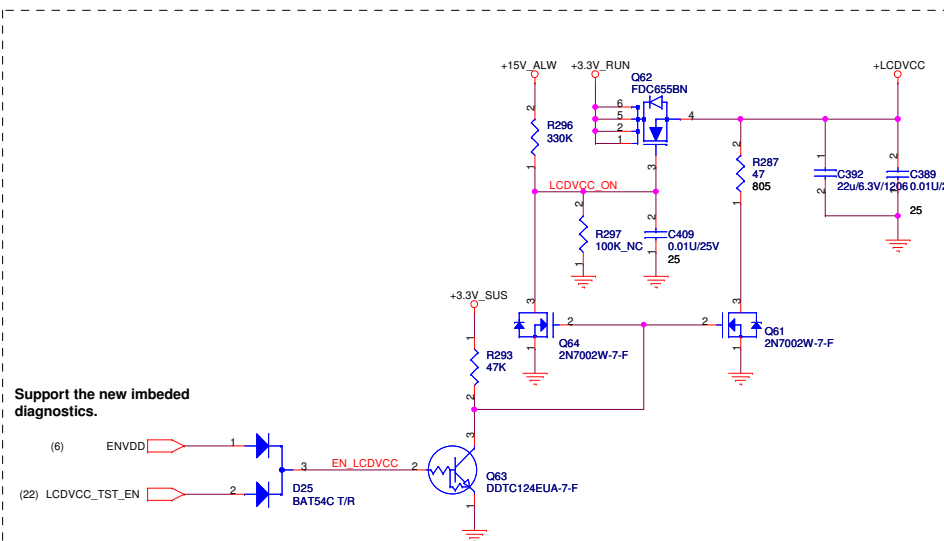

Support the new imbedded diagnostics.

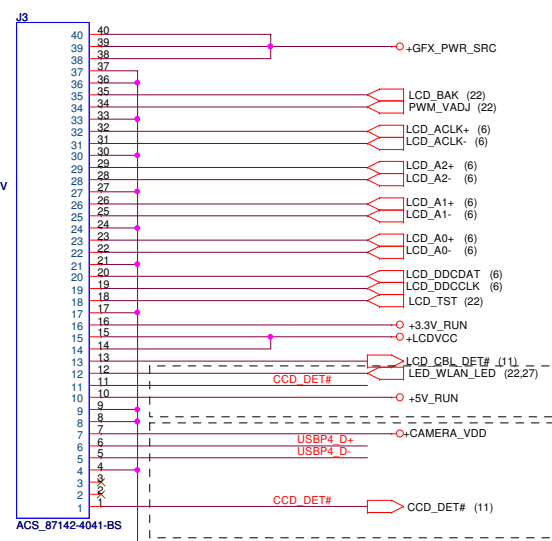
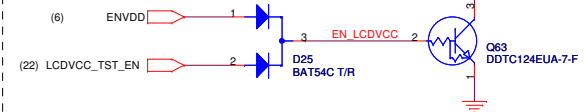

FOR WLAN LED BAR

FOR CCD used

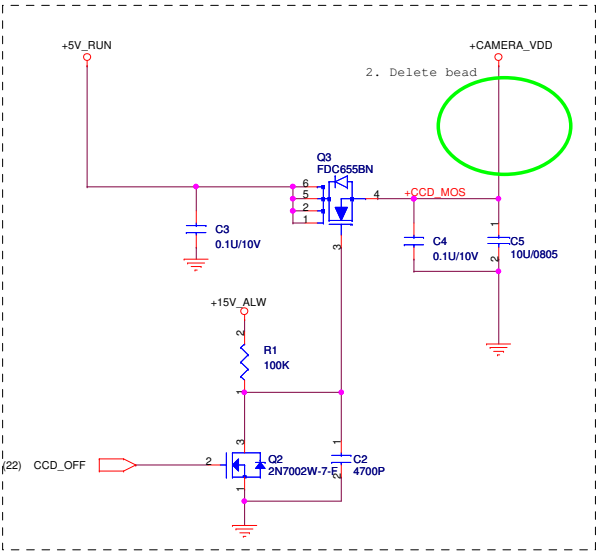
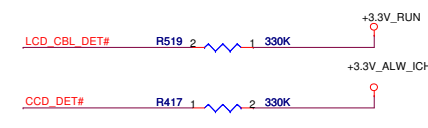
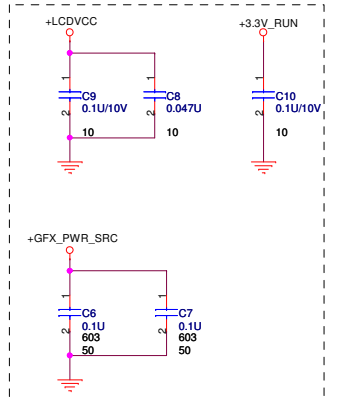

Touch Screen

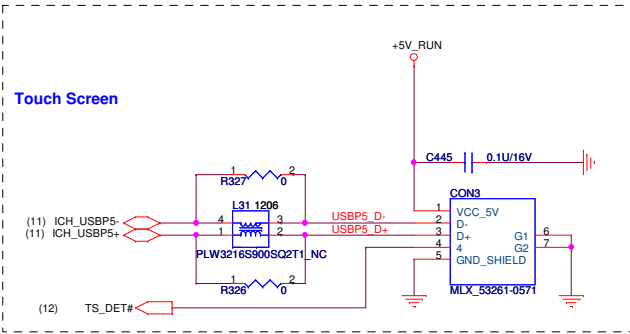

CCD

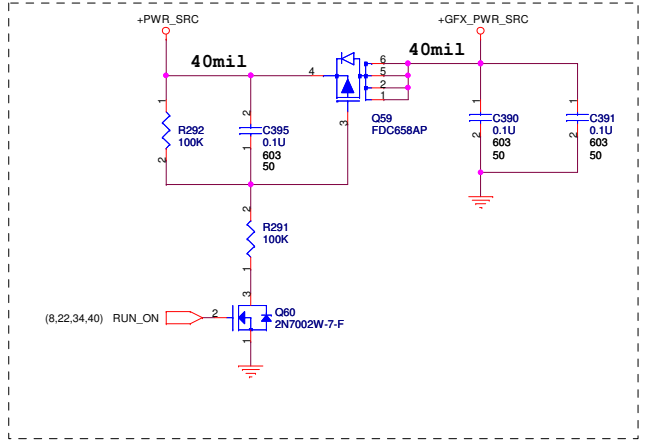
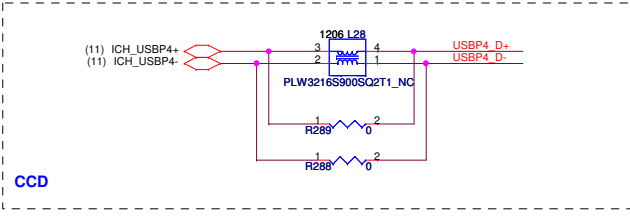

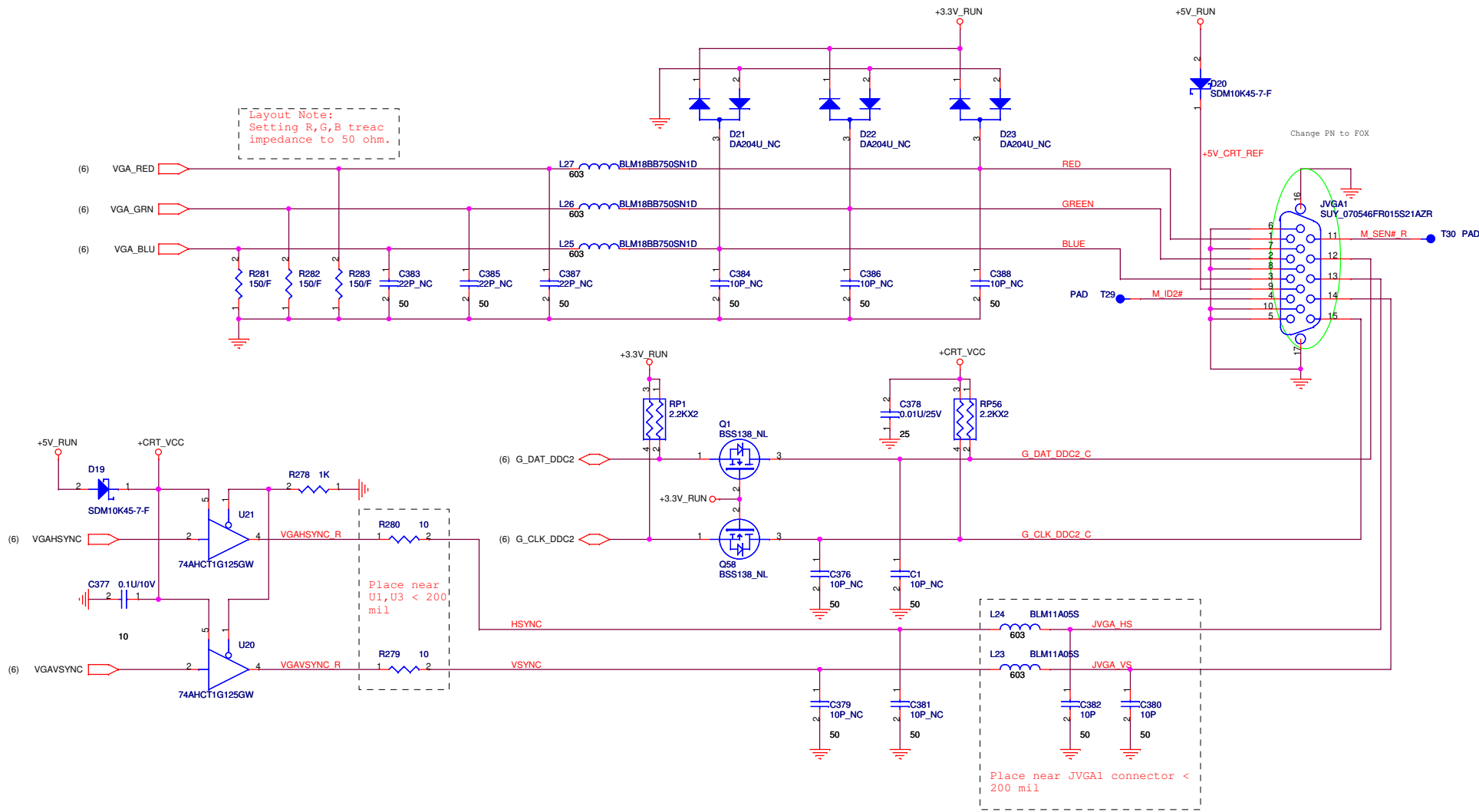

Layout Note:  
Setting R,G,B treac  
impedance to 50 ohm.

Place near  
U1, U3 < 200  
mil

Place near JVG A1  
connector <  
200 mil



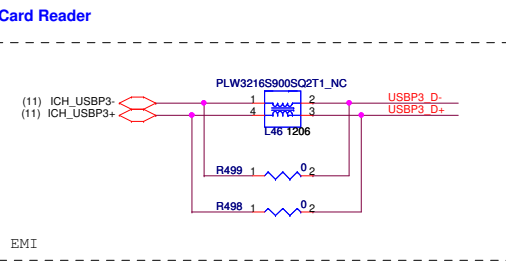
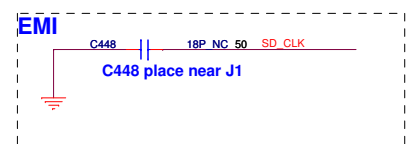
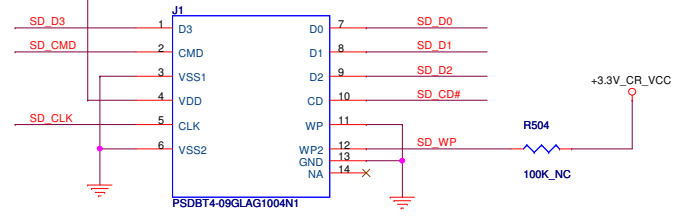
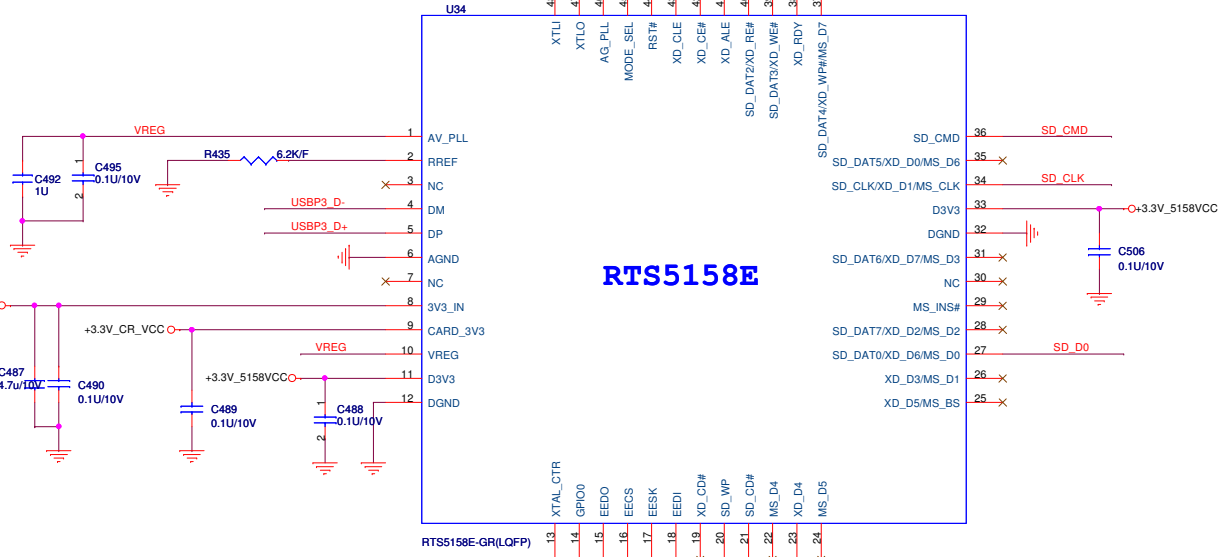
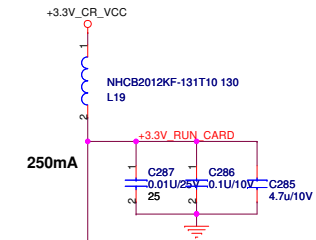
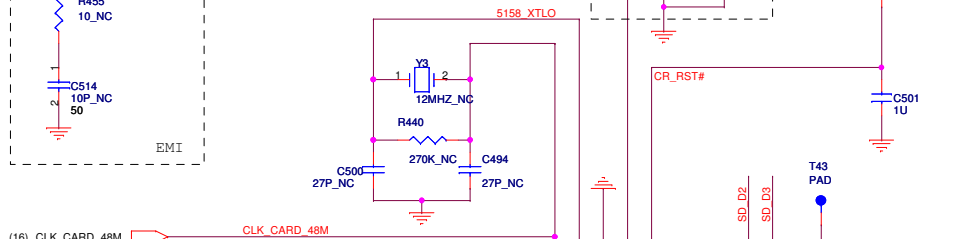
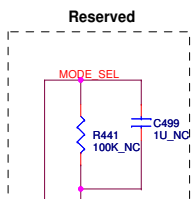
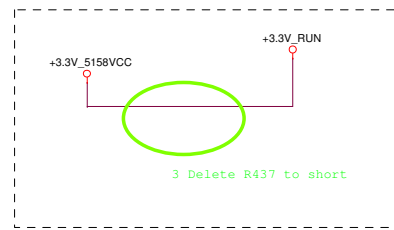
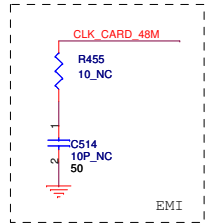



**blank**

 <b>QUANTA COMPUTER</b>		
Title blank		
Size	Document Number ZM1	Rev 3A
Date: Tuesday, March 31, 2009		
Sheet 21 of 46		

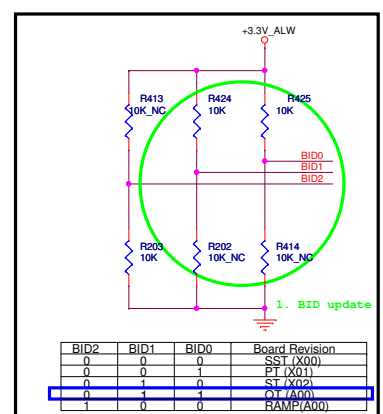
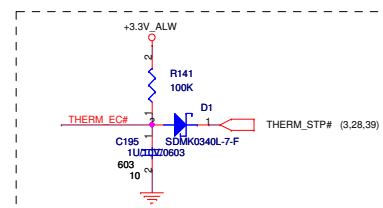
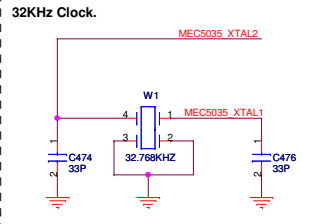
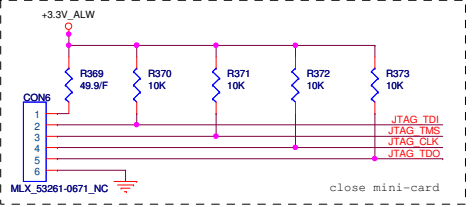
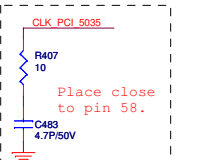
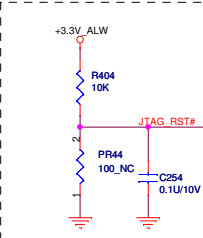
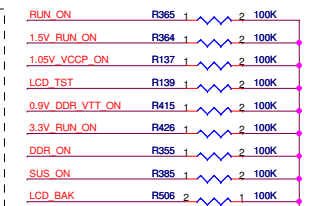
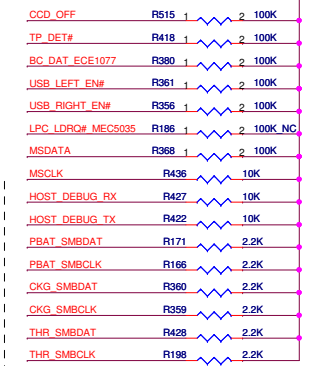
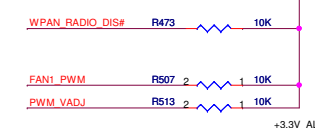
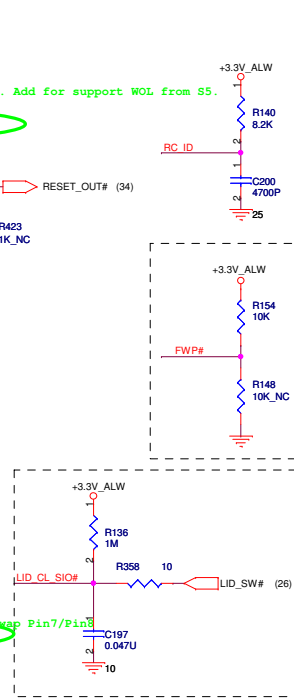
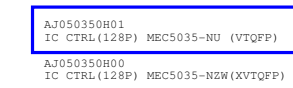
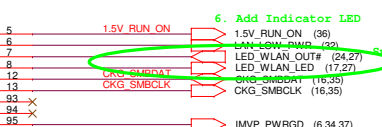
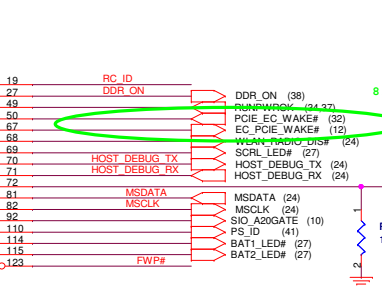
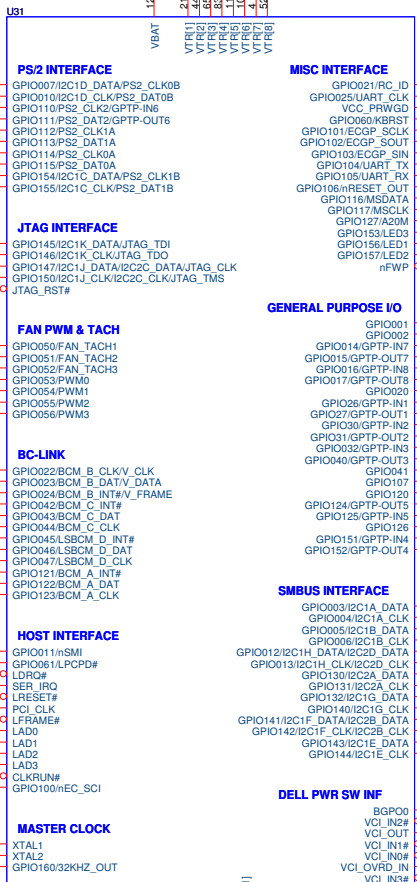
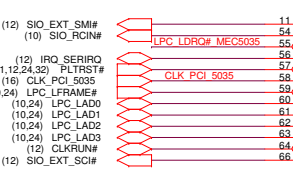
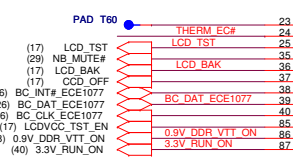
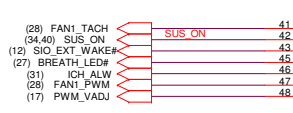
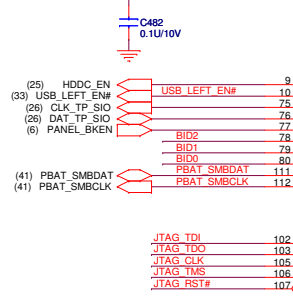
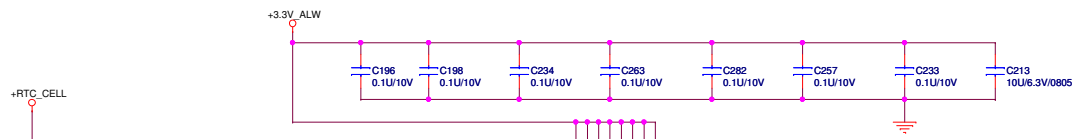

BID2	BID1	BID0	Board Revision
0	0	0	SST (X00)
0	0	1	PT (X01)
0	1	0	ST (X02)
0	1	1	ST (A00)
1	0	0	RAMP(A00)

QUANTA COMPUTER

File: Ultra I/O Controller ECE535

Size: Document Number ZM1

Date: Tuesday, March 31, 2009

Sheet: 22 of 46

Rev: 3A

# 16Mbit (2M Byte), SPI

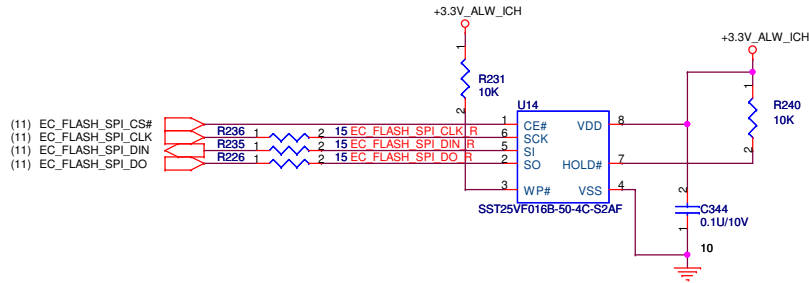

# RTC BATTERY

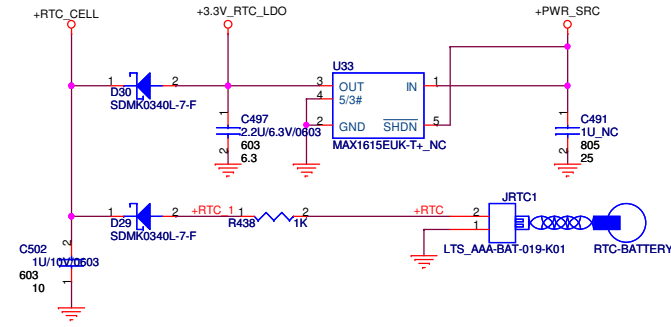

 <b>QUANTA COMPUTER</b>		
Title: Flash / RTC		
Size:	Document Number: ZM1	Rev: 3A
Date:	Tuesday, March 31, 2009	Sheet: 23 of 46

# Half MiniCard WLAN connector

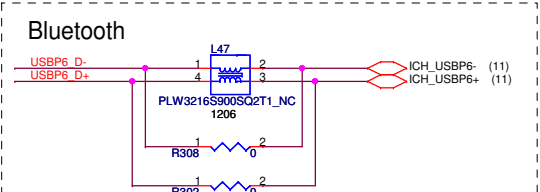
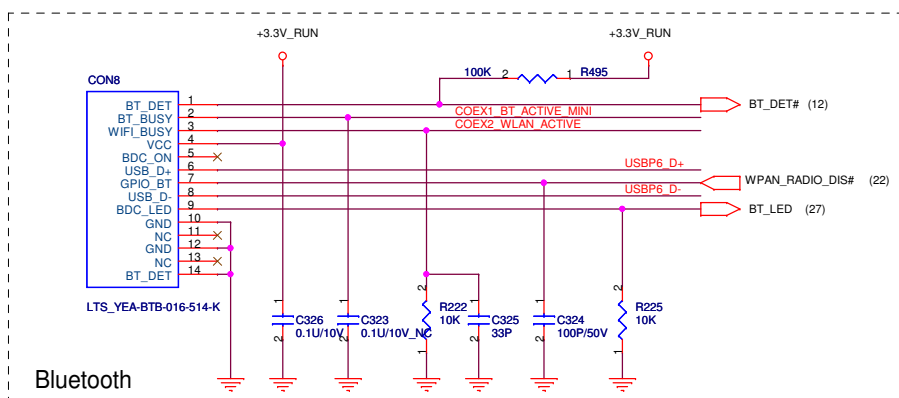
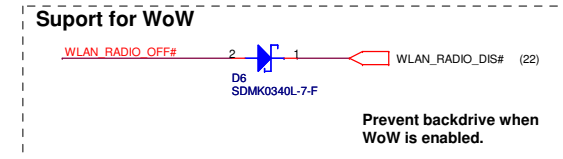
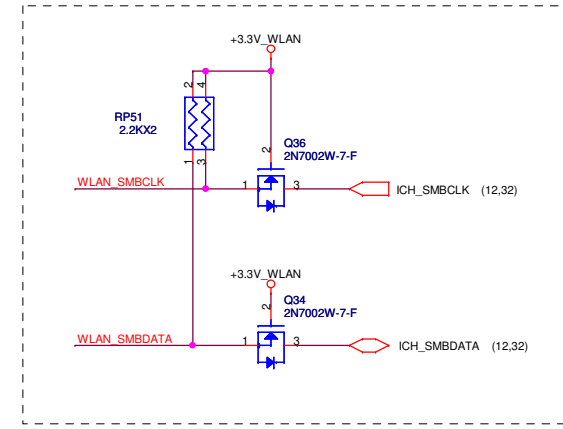
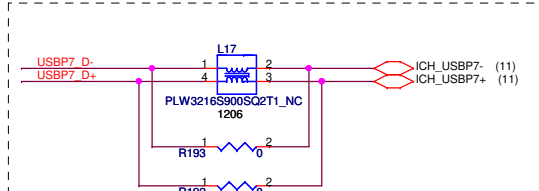
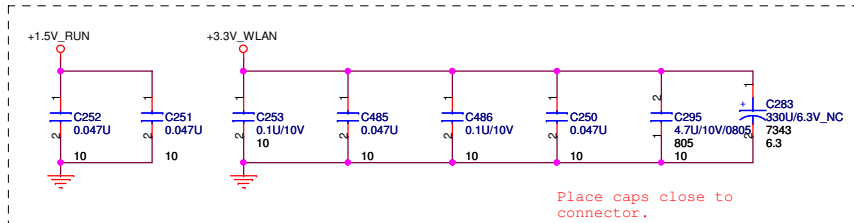
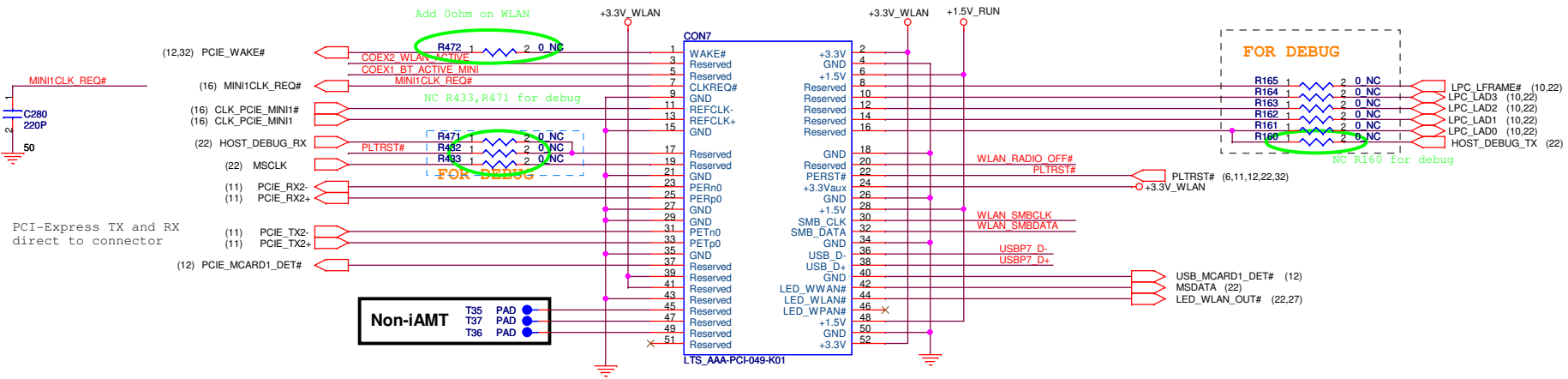



**SATA HDD Connector.**

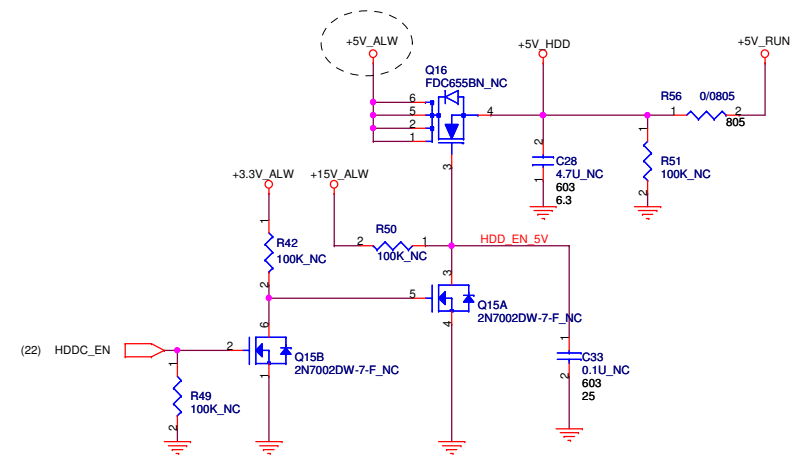
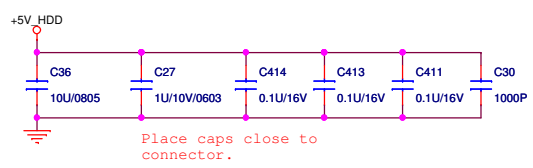
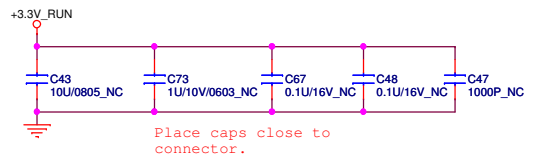
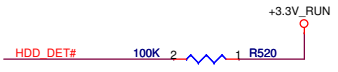
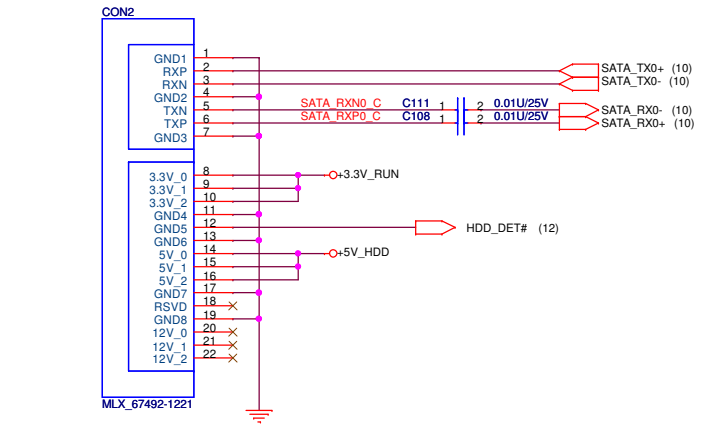

**QUANTA COMPUTER**

Title: SATA (HDD&CD\_ROM)

Size	Document Number ZM1	Rev 3A
------	------------------------	-----------

Date: Tuesday, March 31, 2009 Sheet 25 of 46

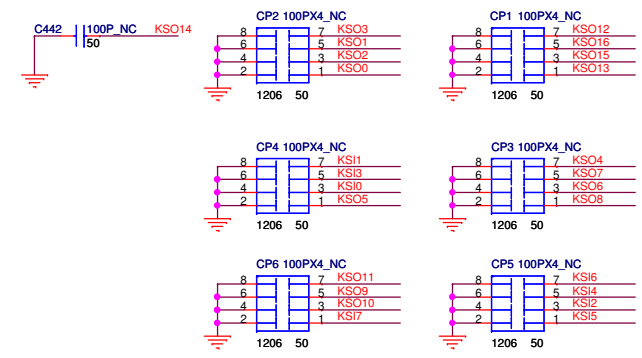
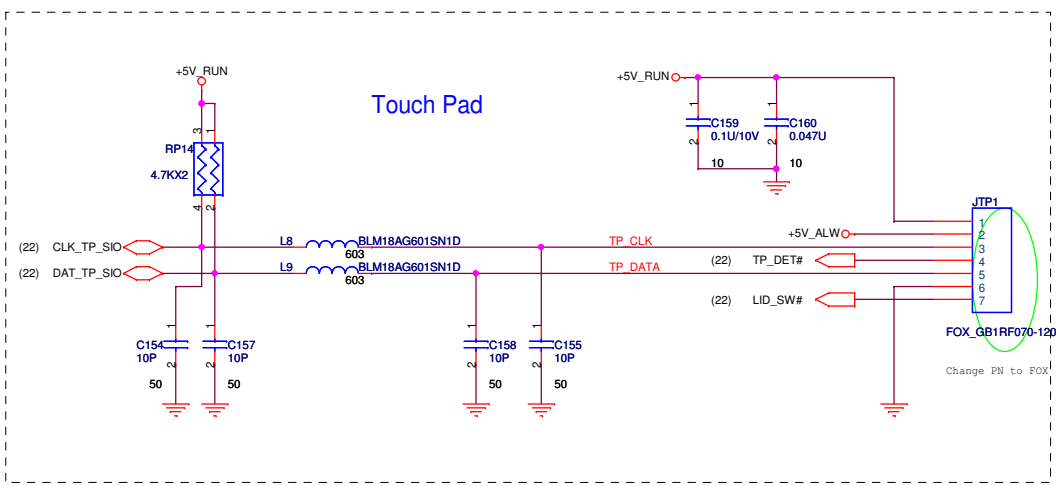

### Keyboard Scan Extension

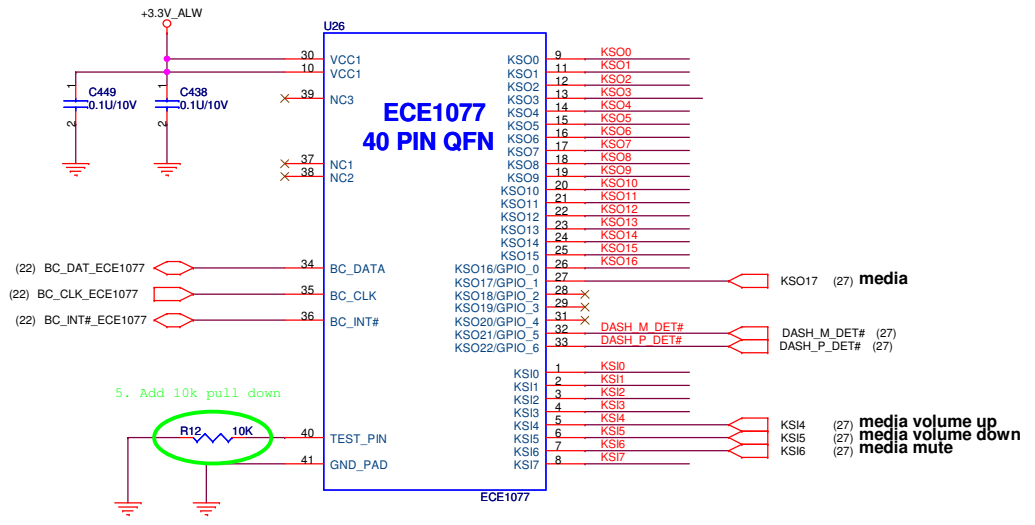

### KEYBOARD CONNECTOR

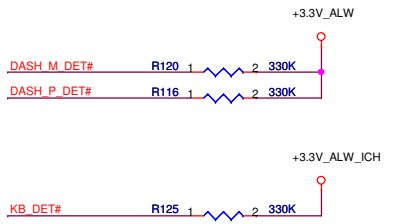
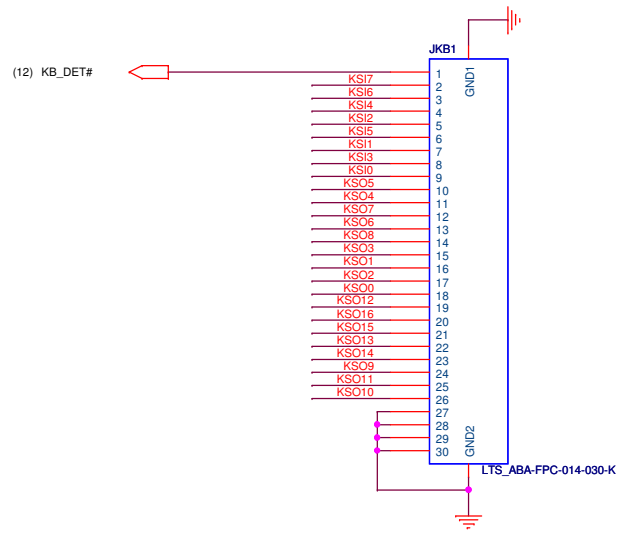

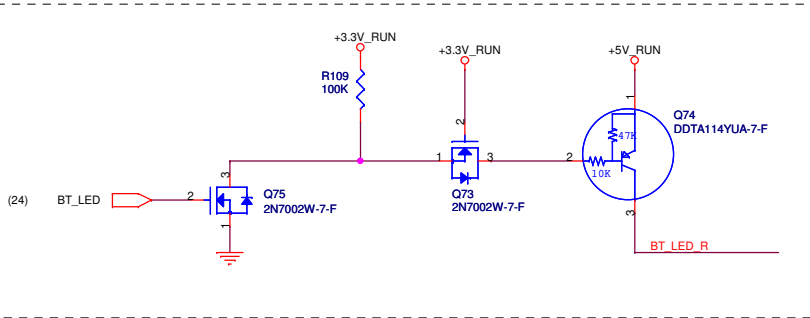
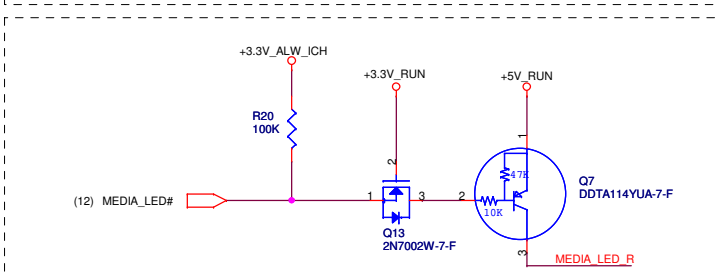
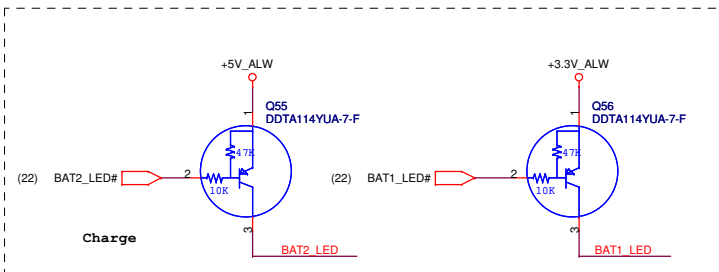
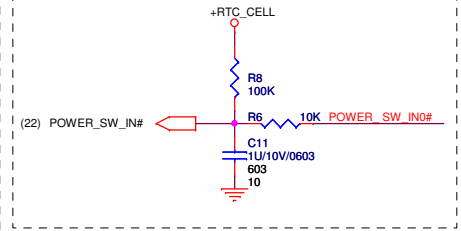
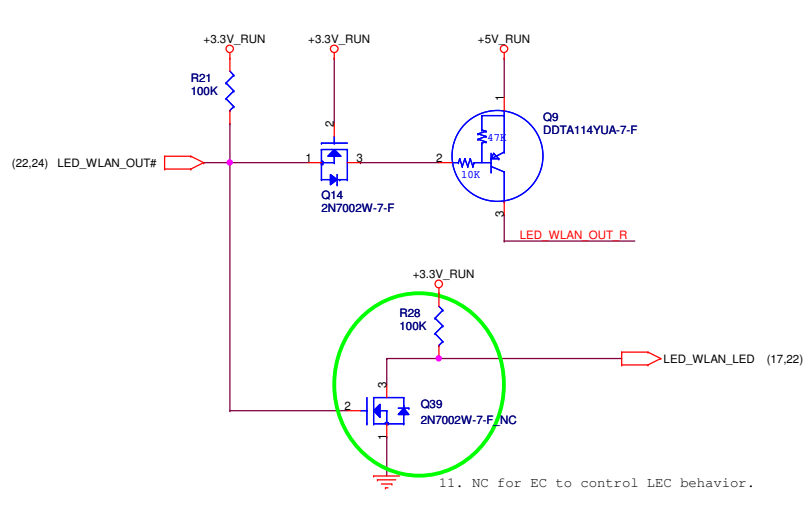
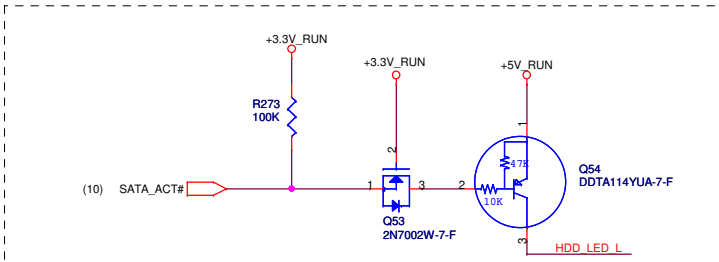
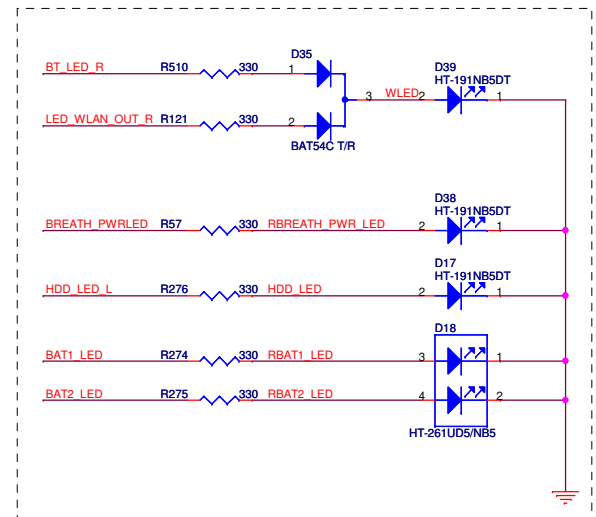
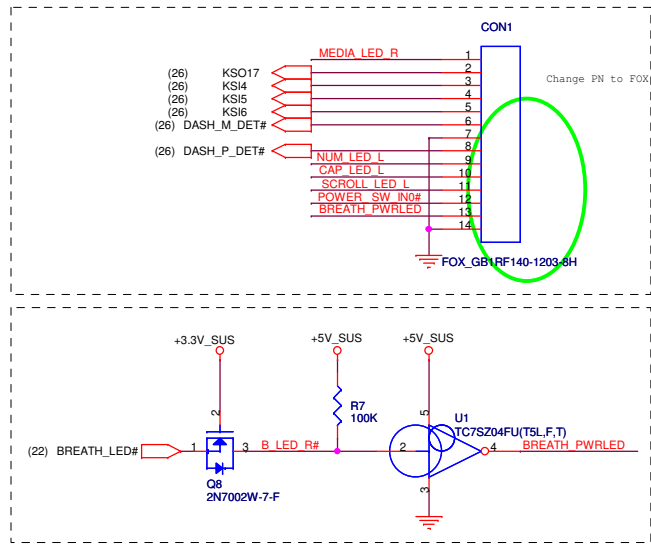
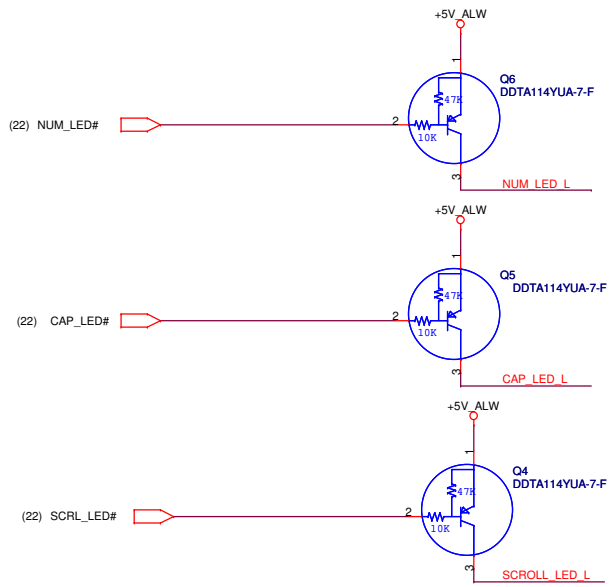

**QUANTA COMPUTER**

Title: SWITCH, KEYBOARD & LED

Size	Document Number	Rev
	ZM1	3A

Date: Tuesday, March 31, 2009 Sheet 27 of 46

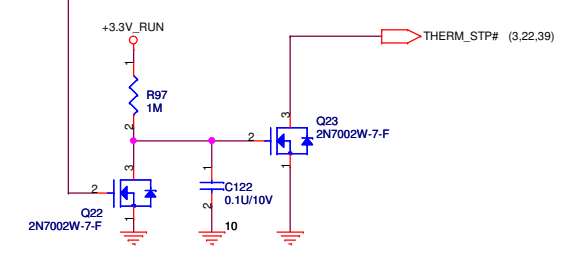
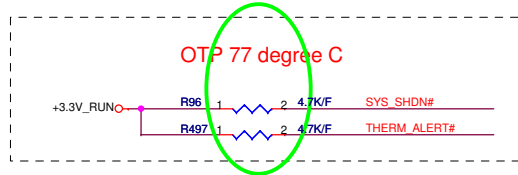
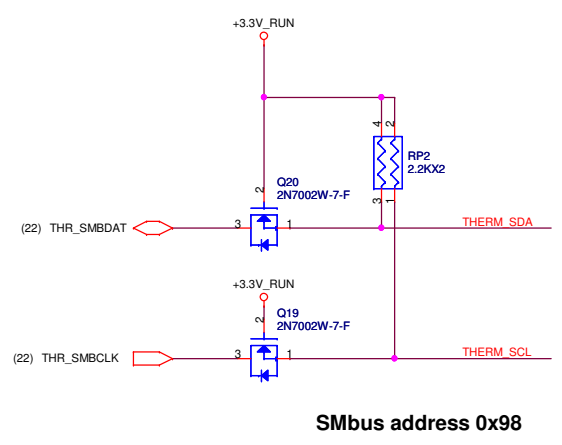
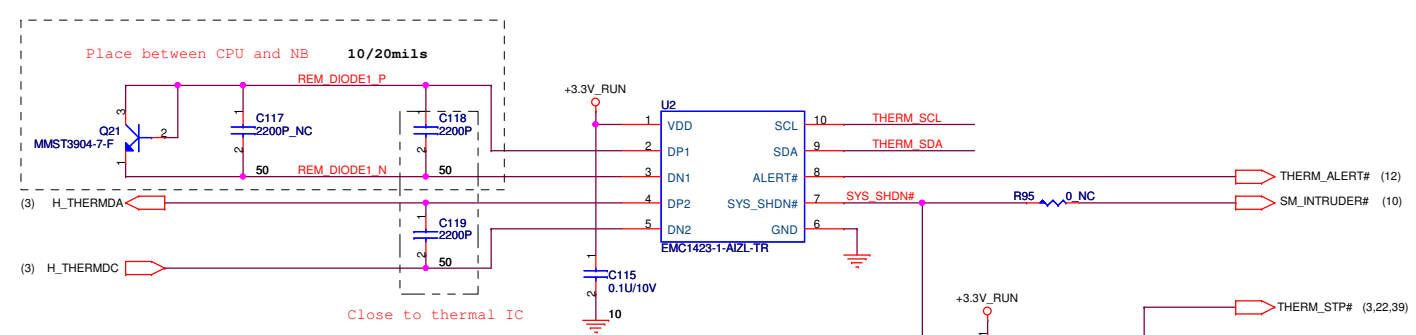
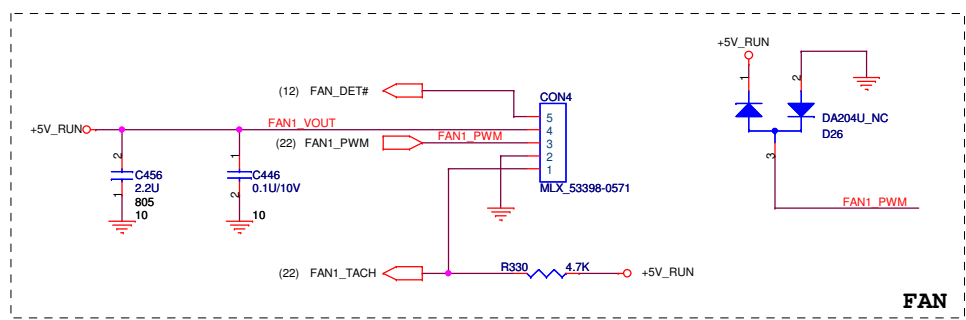

# AUDIO AMPLIFIER TPA6017A2

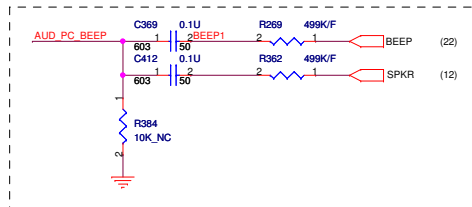
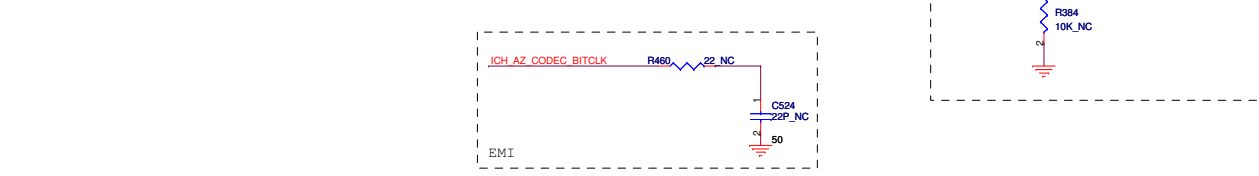
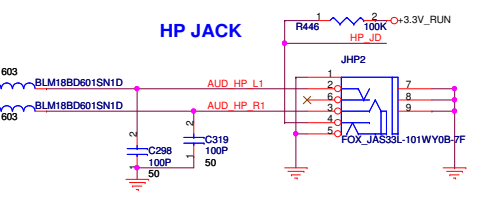
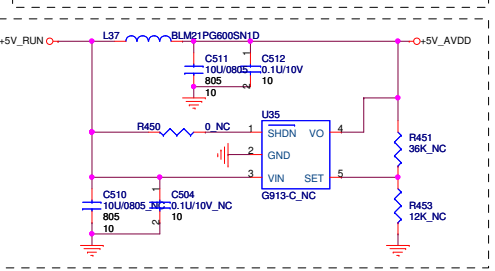
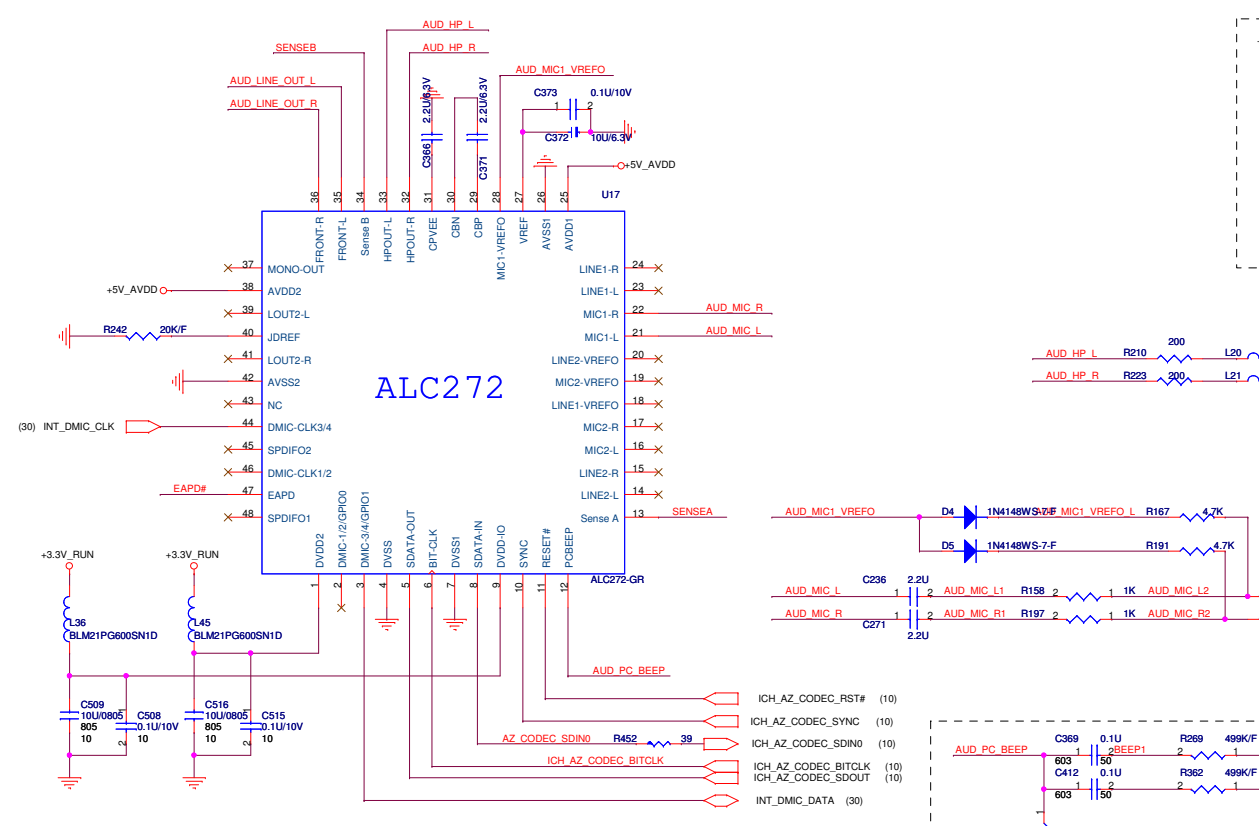
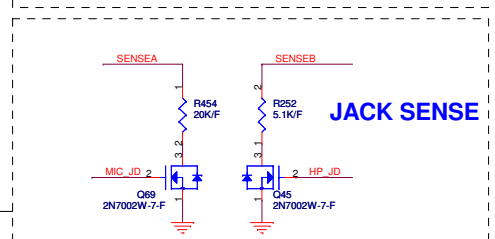
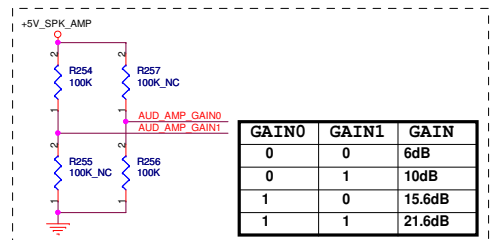
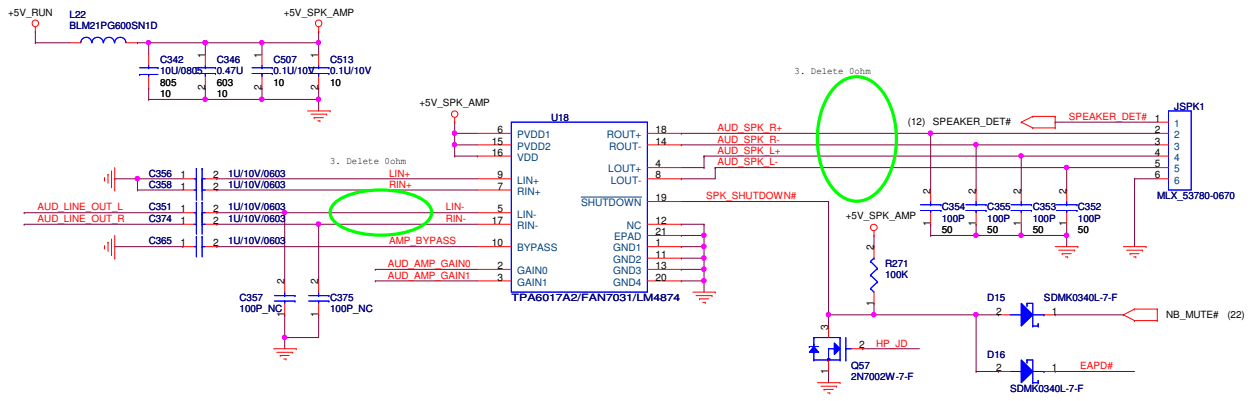

### Internal Digital MIC

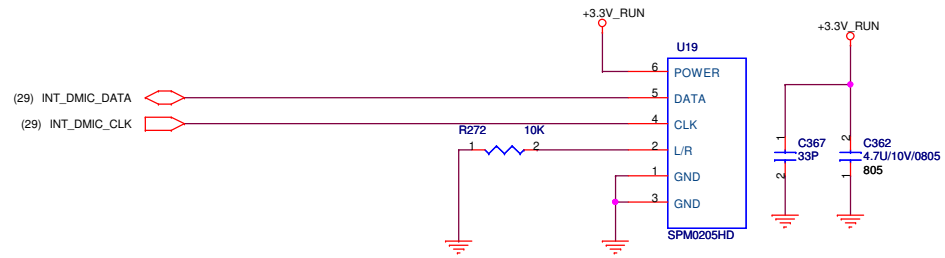

Support Wake on LAN on S5.

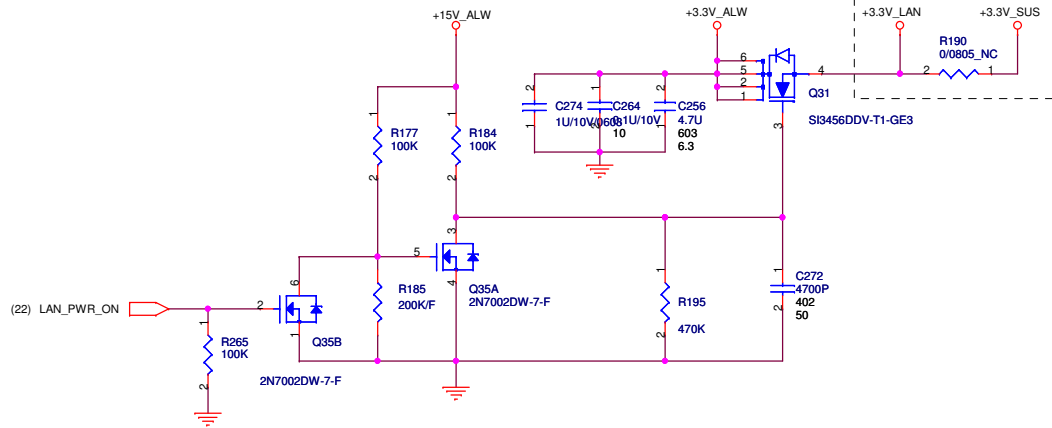

ICH\_ALW

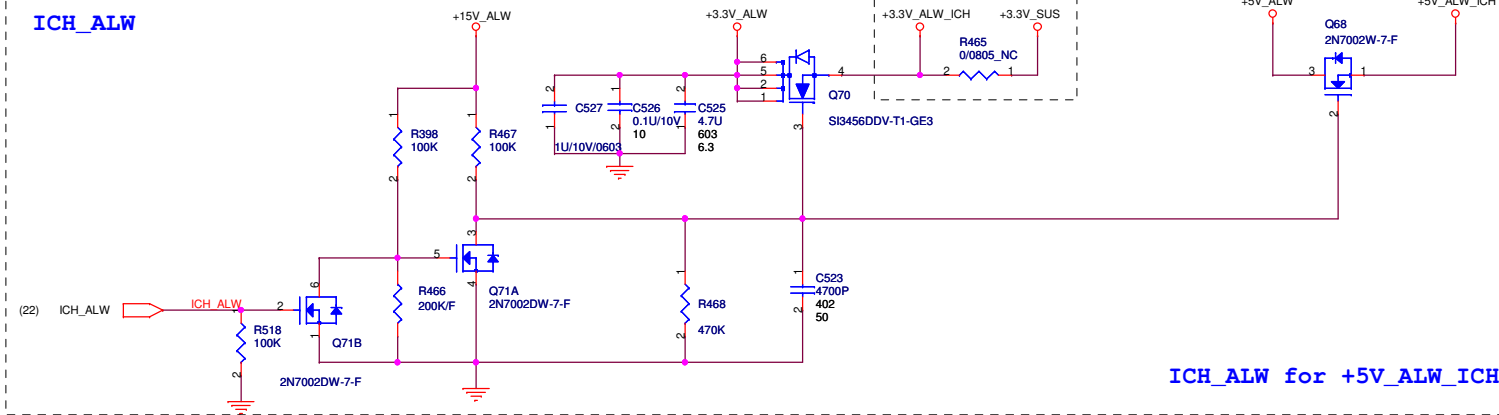

ICH\_ALW for +5V\_ALW\_ICH

WLAN POWER

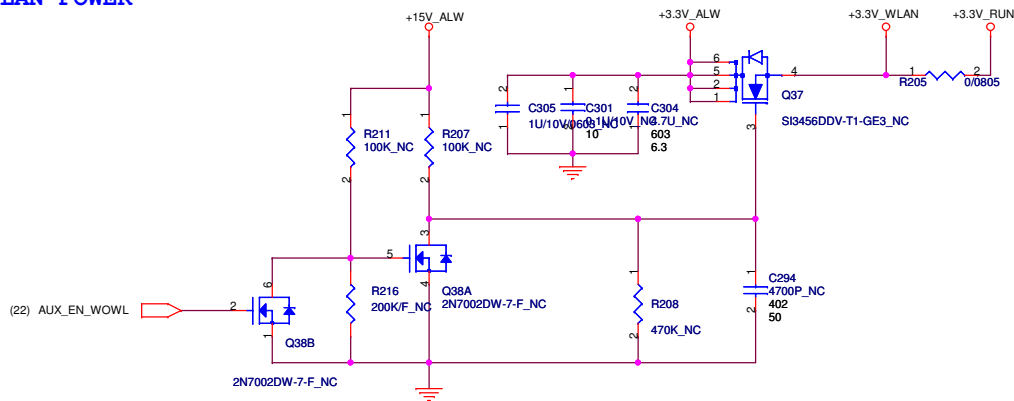

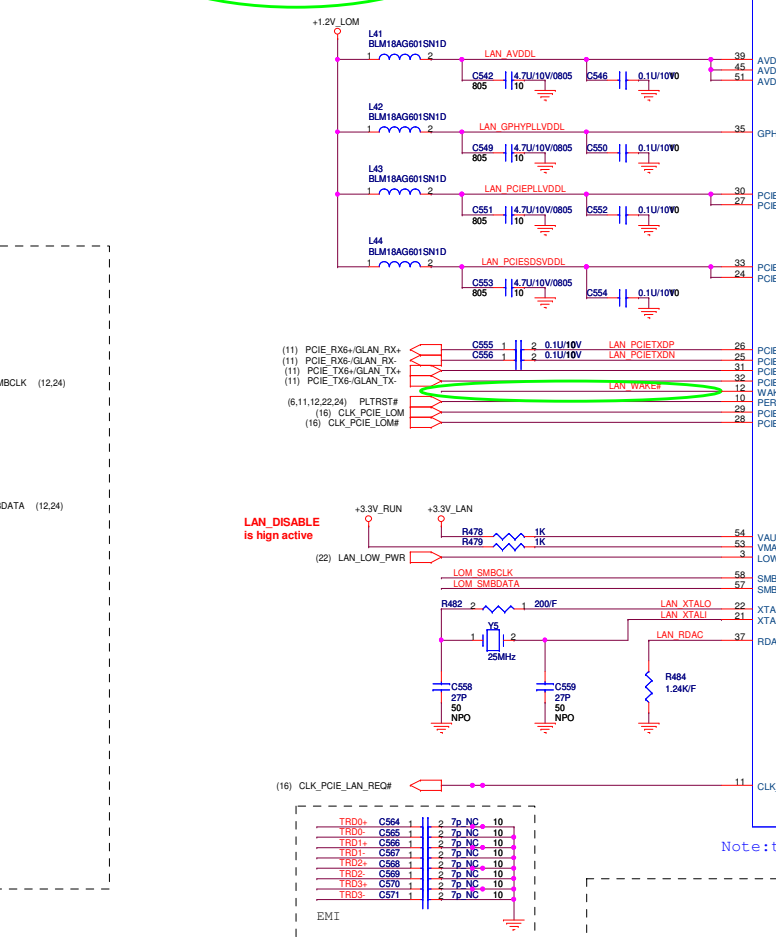
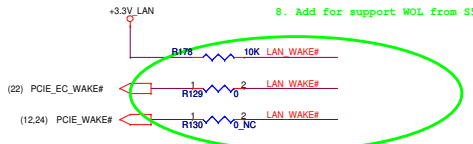
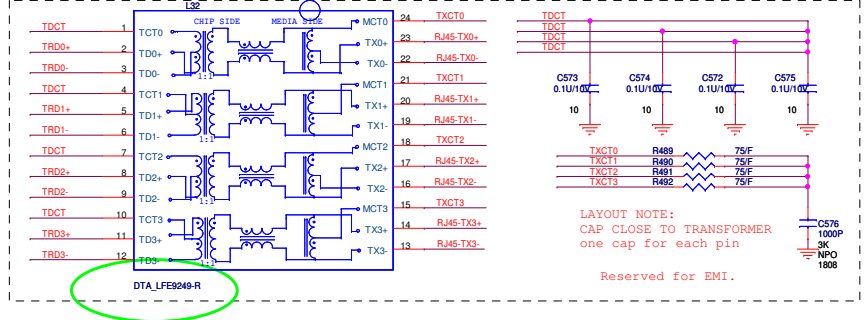
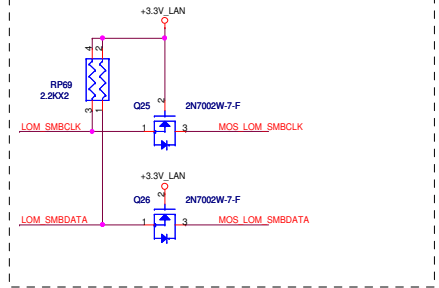
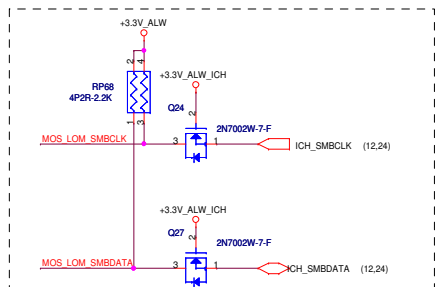
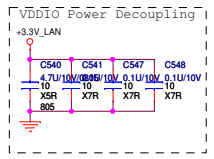
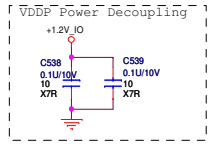
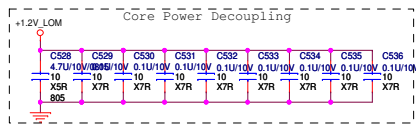

EMI

TRD0+	C564	1	2	7p	NC	10
TRD0-	C565	1	2	7p	NC	10
TRD1+	C566	1	2	7p	NC	10
TRD1-	C567	1	2	7p	NC	10
TRD2+	C568	1	2	7p	NC	10
TRD2-	C569	1	2	7p	NC	10
TRD3+	C570	1	2	7p	NC	10
TRD3-	C571	1	2	7p	NC	10

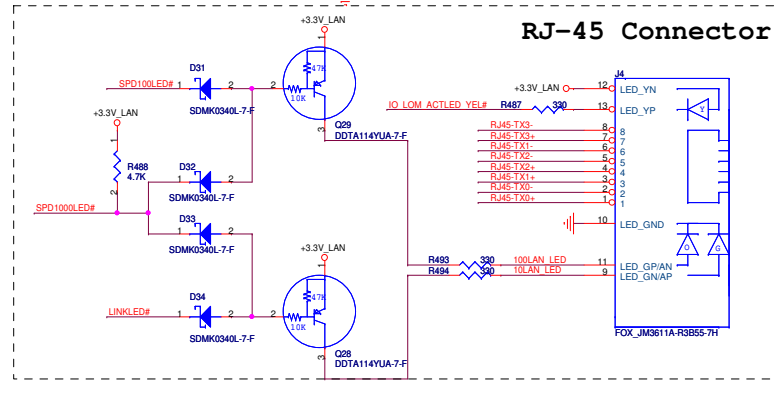
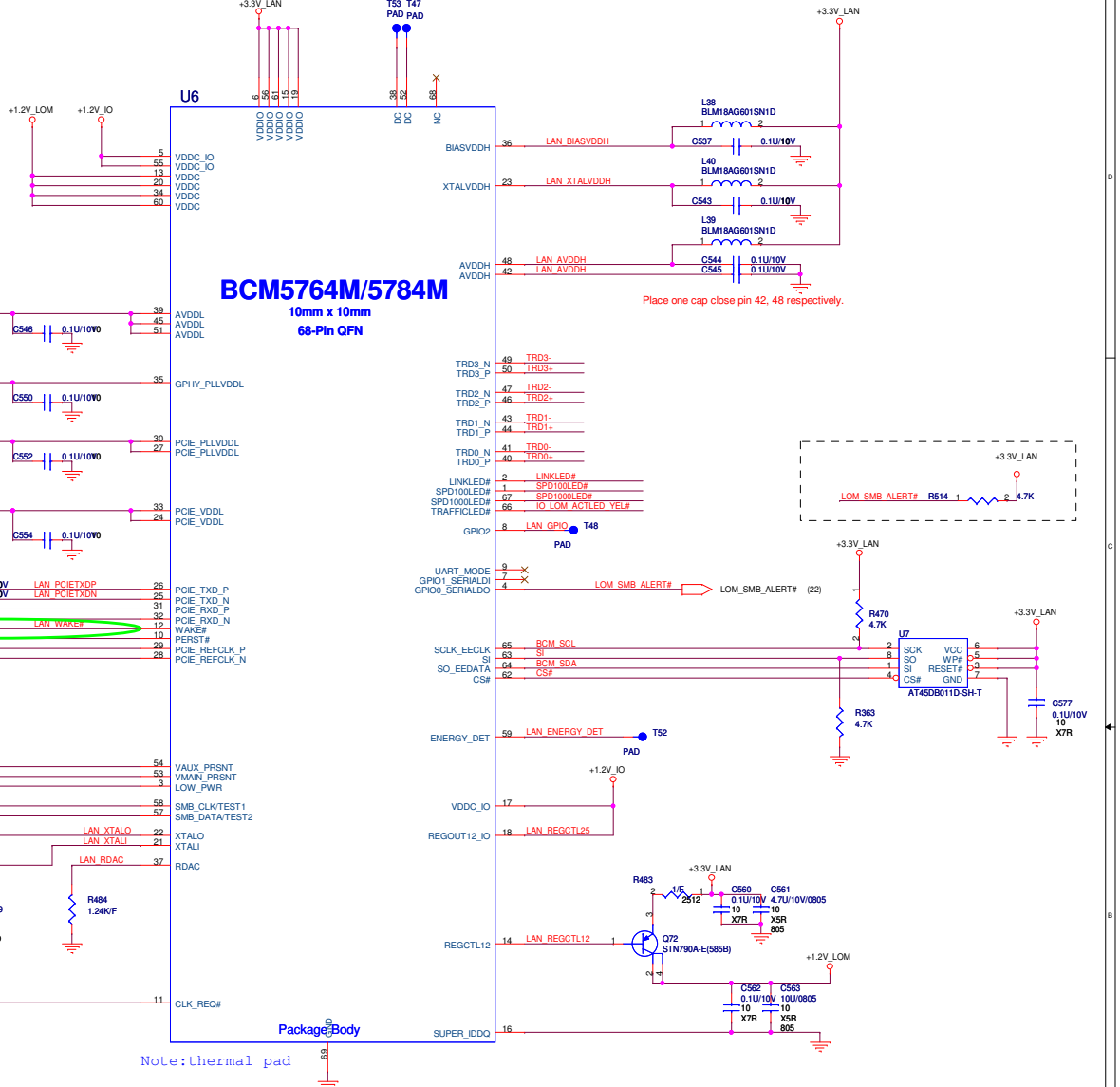

**QUANTA COMPUTER**

Title: LAN BCM5464M  
 Size: Document Number 2M1  
 Date: Tuesday, March 31, 2009 Sheet 32 of 46



External USB PORT hookup reference. Your design may need more or less external ports and may be mapped differently

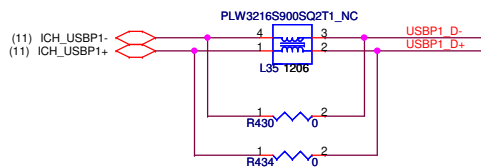
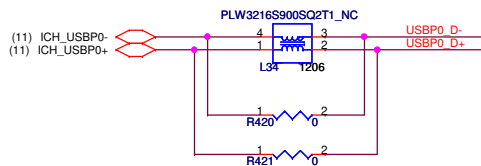

Platforms should put in PADS for the USB chokes if they have the room. Chokes should be NOPOP.

# USB Right Side x2

Place ESD diodes as close as USB connector.

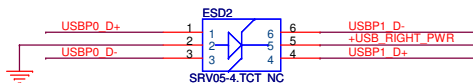

Place one 150uF cap by each USB connector.

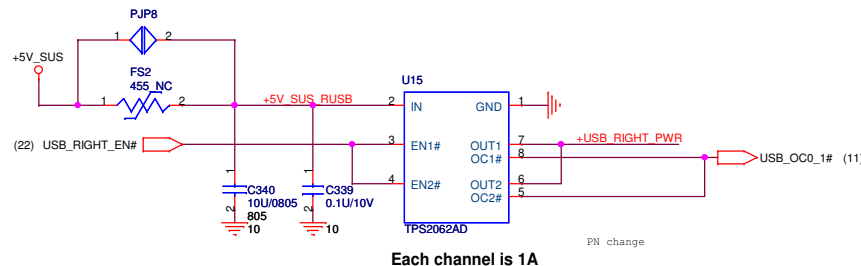
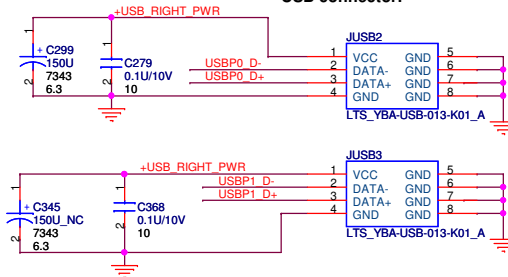

# USB Left Side

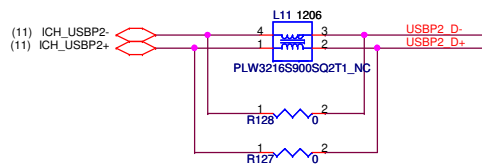

Platforms should put in PADS for the USB chokes if they have the room. Chokes should be NOPOP.

Place ESD diodes as close as USB connector.

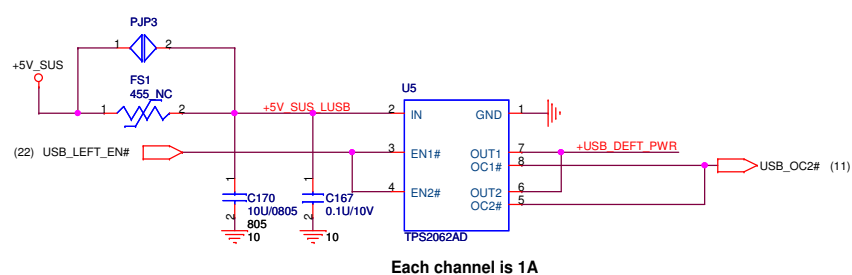
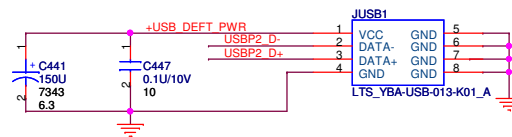
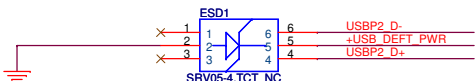

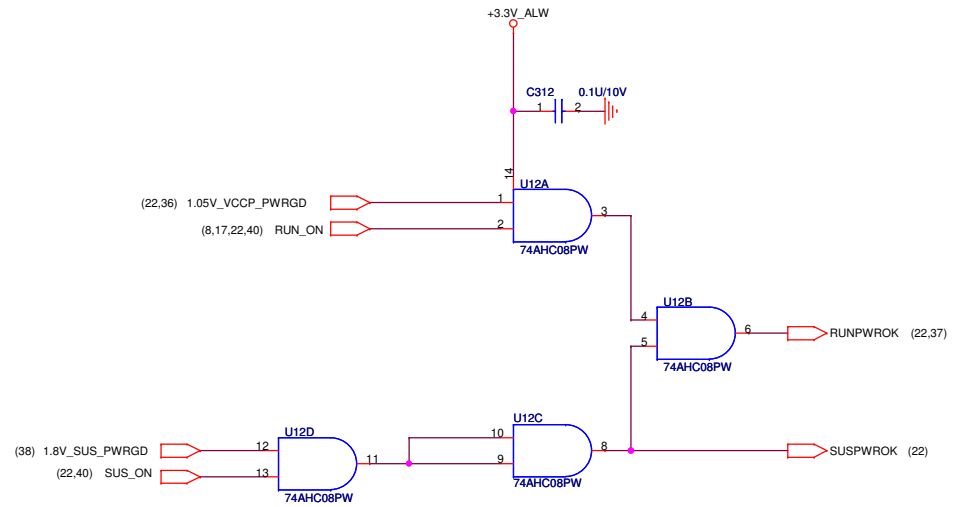
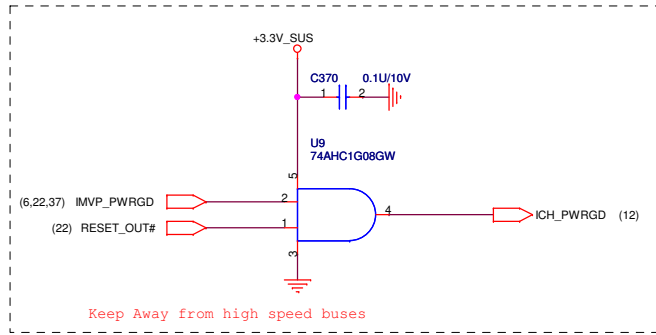

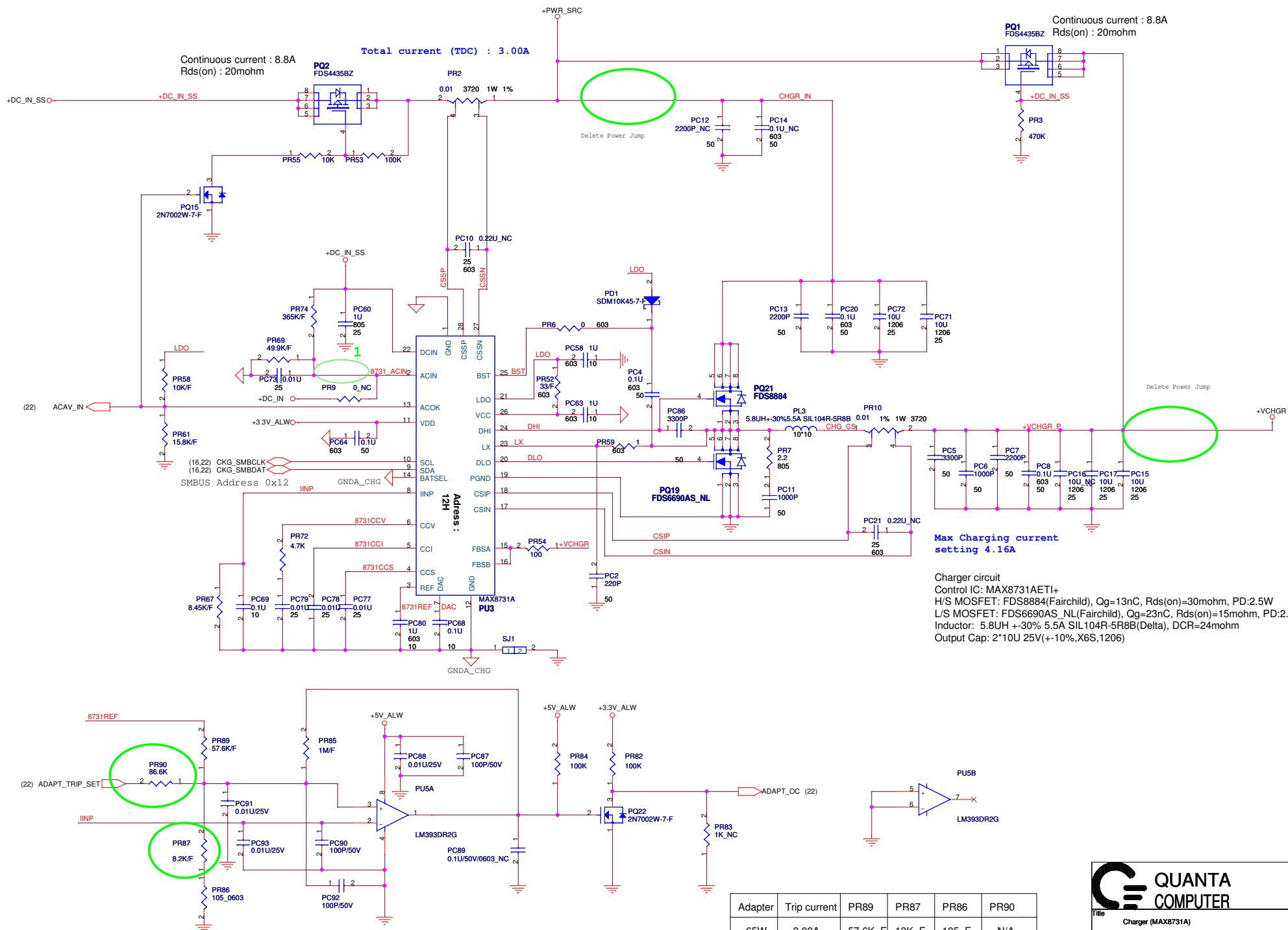

Max Charging current setting 4.16A

Charger circuit  
 Control IC: MAX8731AETI+  
 H/S MOSFET: FDS8884(Fairchild), Qg=13nC, Rds(on)=30mohm, PD:2.5W  
 L/S MOSFET: FDS6690AS\_NL(Fairchild), Qg=23nC, Rds(on)=15mohm, PD:2.5W  
 Inductor: 5.8UH +/-30% 5.5A SIL104R-5R8B(Delta), DCR=24mohm  
 Output Cap: 2\*10U 25V(+10%,X6S,1206)

Adapter	Trip current	PR89	PR87	PR86	PR90
65W	3.00A	57.6K_F	13K_F	105_F	N/A

**QUANTA COMPUTER**

Title: Charger (MAX8731A)

Size: ZM1      Document Number: ZM1      Rev: 2B

Date: Tuesday, March 31, 2009      Sheet: 35 of 46

1.05V\_VCCP power rail:  
 Control IC: TPS51117RGYR  
 H/S MOSFET: FDS8884(Fairchild), Qg=13nC, Rds(on)=30mohm, PD:2.5W  
 L/S MOSFET: FDS6690AS\_NL(Fairchild), Qg=23nC, Rds(on)=15mohm, PD:2.5W  
 Inductor: 1.5UH +-30% 10A SIL104R-1R5B(Delta), DCR=8.1mohm  
 Output Cap: 1\*220U 2.5V(20%,7343 ,H1.9), ESR15, ripple current 3500mArms

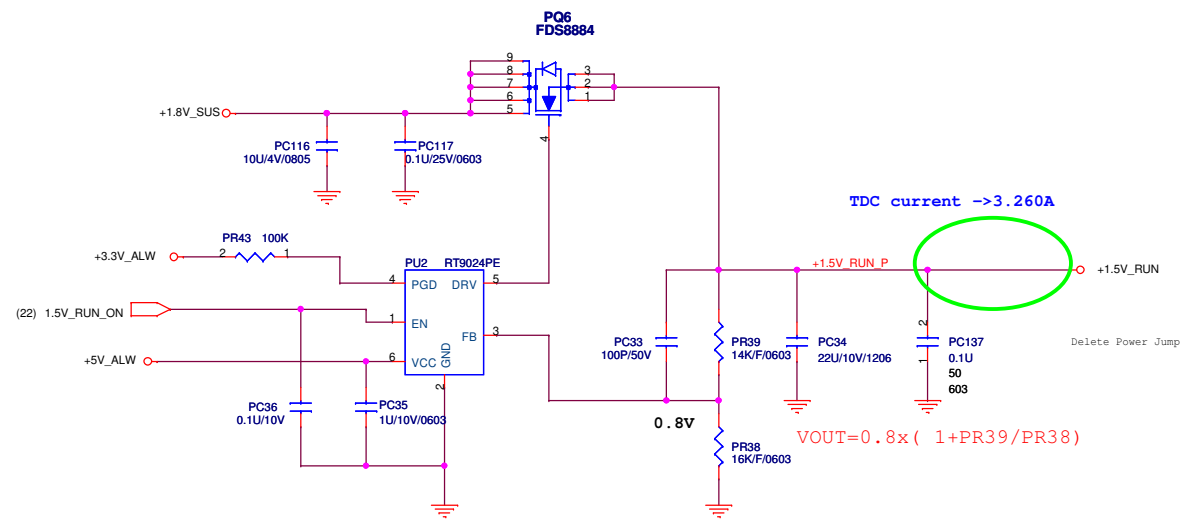
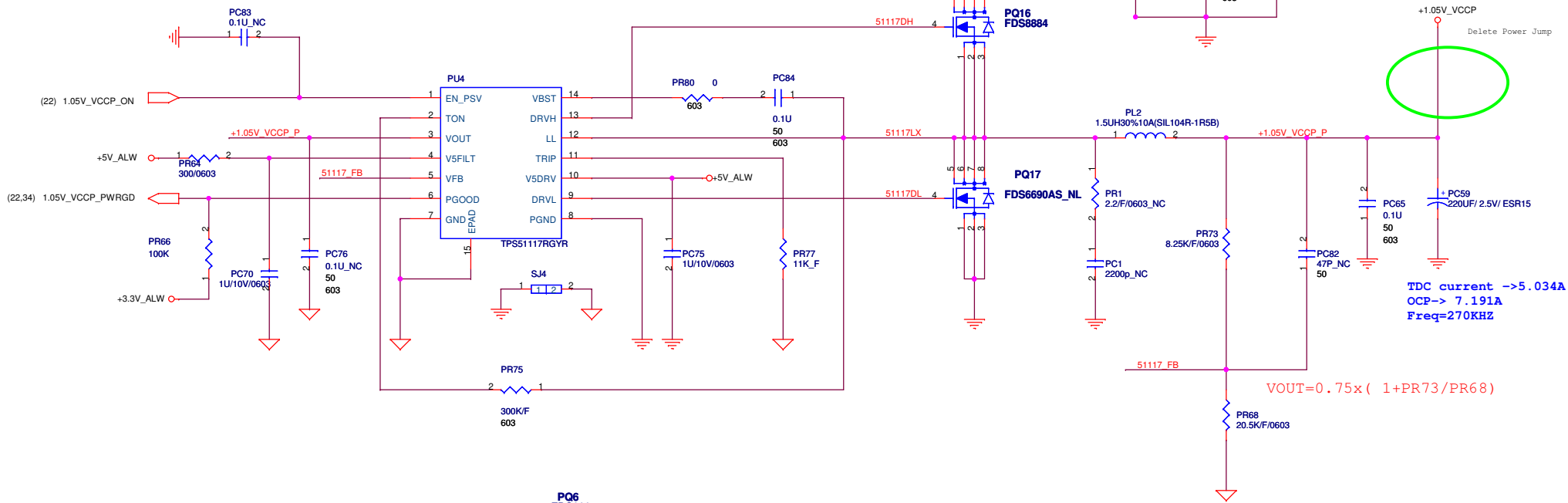

CPU Vcore power rail:  
 Control IC: MAX8796GTJ+  
 H/S MOSFET: FDS8884(Fairchild), Qg=13nC, Rds(on)=30mohm, PD:2.5W  
 L/S MOSFET: FDS6690AS\_NL(Fairchild), Qg=23nC, Rds(on)=15mohm, PD:2.5W  
 Inductor: 3.3UH +-20% 13.5A(MPLC0730L3R3)DCR=30mohm  
 Output Cap: 1\*330U 2V(+10/-35%,7343,ESR=6), ripple current 3500mArms

- TP6 CPU\_VID0
- TP7 CPU\_VID1
- TP5 CPU\_VID2
- TP2 CPU\_VID3
- TP3 CPU\_VID4
- TP4 CPU\_VID5
- TP1 CPU\_VID6

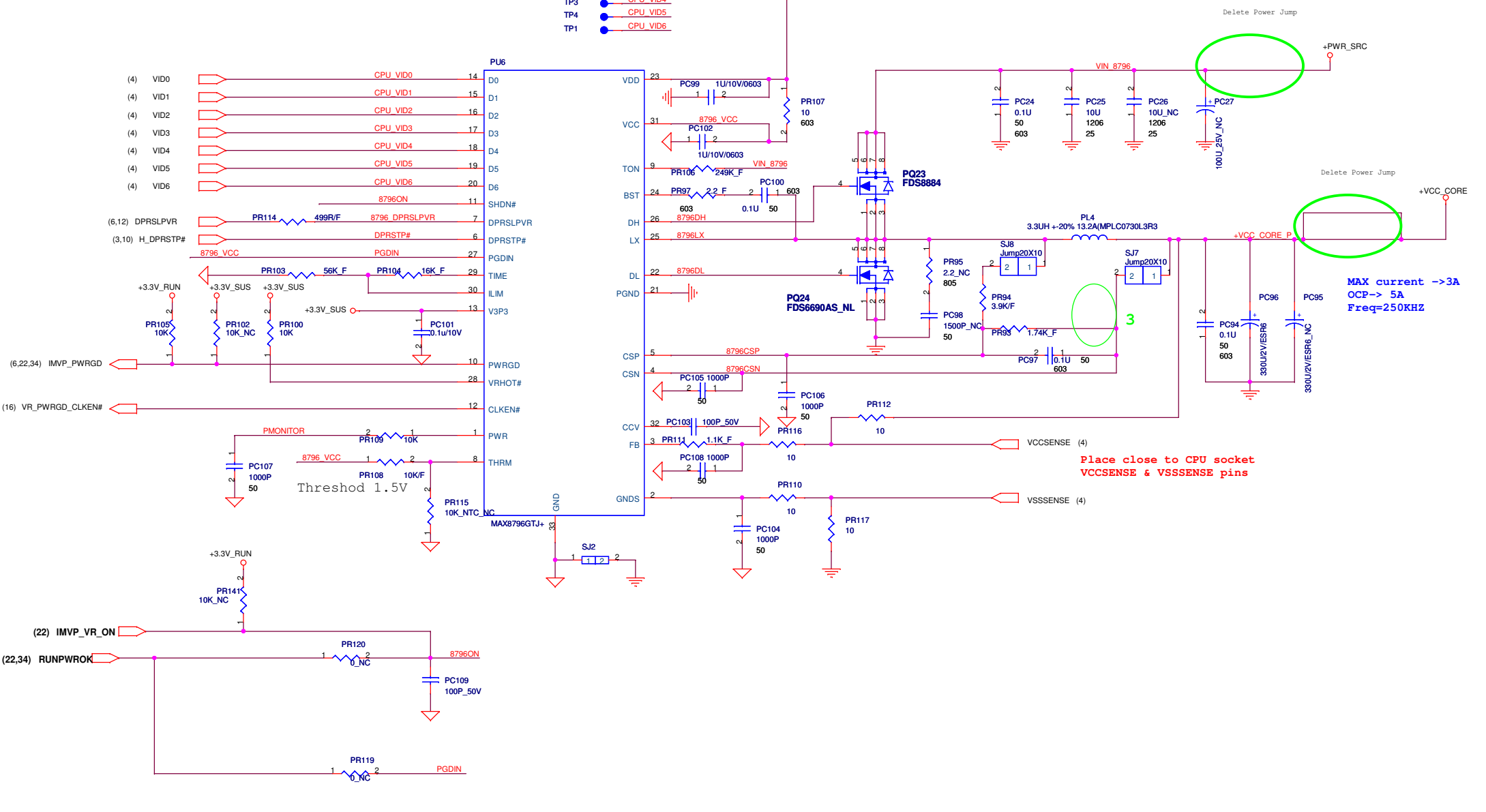

**QUANTA COMPUTER**

File		CPU_MAX8796
Size	Document Number	Rev
	ZM1	2B
Date:	Tuesday, March 31, 2009	Sheet 37 of 46

1.8V\_SUS power rail:  
 Control IC: TPS51116PWPRG4  
 H/S MOSFET: FDS8878(Fairchild), Qg=26nC, Rds(on)=17mohm, PD:2.5W  
 L/S MOSFET: FDS6680AS\_NL(Fairchild), Qg=30nC, Rds(on)=10.5mohm, PD:2.5W  
 Inductor: 1.5uH +/-30%12.5A(SIL1055RC-1R5-R)(Delta), DCR=7.6mohm  
 Output Cap: 1\* 220u2.5V(20%,ESR15,7343,H1.9), ripple current 3500mArms

VDDQ and VTT discharge control

MODE pin	Discharge mode
V5IN	No discharge
VDDQ	Tracking discharge
S4/GND	Non-tracking discharge

VDDQ output voltage selection

VDDQSET	VDDQ (V)	VTTREF and VTT	NOTE
GND	2.5V	VDDQSNS/2	DDR
V5IN	1.8V	VDDQSNS/2	DDR2
FB Resistors	Adjusting	VDDQSNS/2	1.5V < VVDDQ < 3V

Outputs Management by S3, S5 control

State	S3	S5	VDDQ	VTTREF	VTT
S0	HI	HI	On	On	On
S3	LO	HI	On	On	Off (Hi-Z)
S4/S5	LO	LO	On (discharge)	Off (discharge)	Off (discharge)

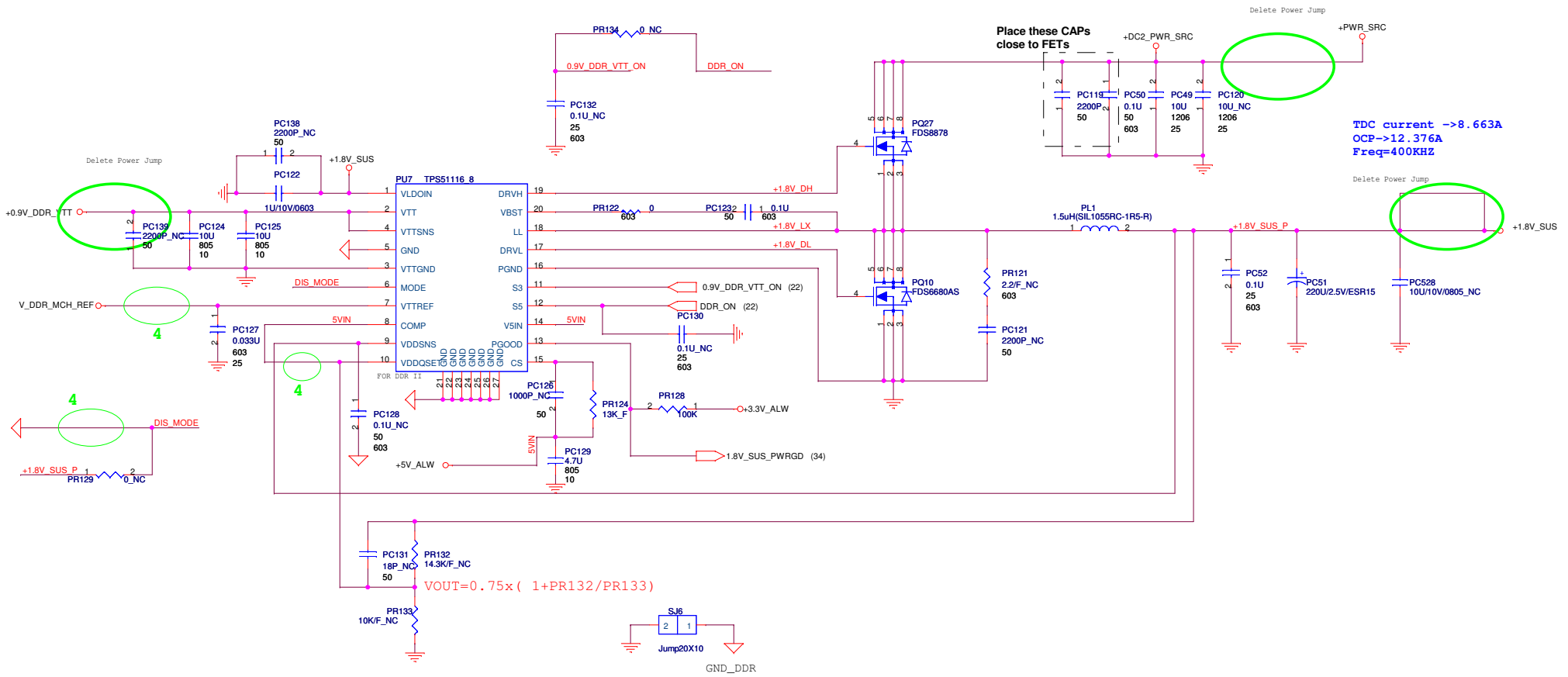

Place these CAPS close to FETs

Delete Power Jump

TDC current -> 8.663A  
 OCP -> 12.376A  
 Freq=400KHZ

Delete Power Jump

$$V_{OUT} = 0.75 \times (1 + PR132/PR133)$$



5V\_ALW power rail:  
 Control IC: MAX17020ETJ+  
 H/S MOSFET: FDS8884(Fairchild), Qg=13nC, Rds(on)=30mohm, PD:2.5W  
 L/S MOSFET: FDS8884(Fairchild), Qg=13nC, Rds(on)=30mohm, PD:2.5W  
 Inductor: 3.8UH 30% 6A(SIL104R-3R8B)(Delta), DCR=13mohm  
 Output Cap: 1\* 330U,6.3V(20%ESR17,6.3\*5.8), ripple current 3500mArms

# DC/DC +3V\_ALW/+5V\_ALW /+15V\_ALW

3.3V\_ALW power rail:  
 Control IC: MAX17020ETJ+  
 H/S MOSFET: FDS8884(Fairchild), Qg=13nC, Rds(on)=30mohm, PD:2.5W  
 L/S MOSFET: FDS8884(Fairchild), Qg=13nC, Rds(on)=30mohm, PD:2.5W  
 Inductor: 3.8UH 30% 6A(SIL104R-3R8B)(Delta), DCR=13mohm  
 Output Cap: 1\* 330U,6.3V(20%ESR17,6.3\*5.8), ripple current 3500mArms

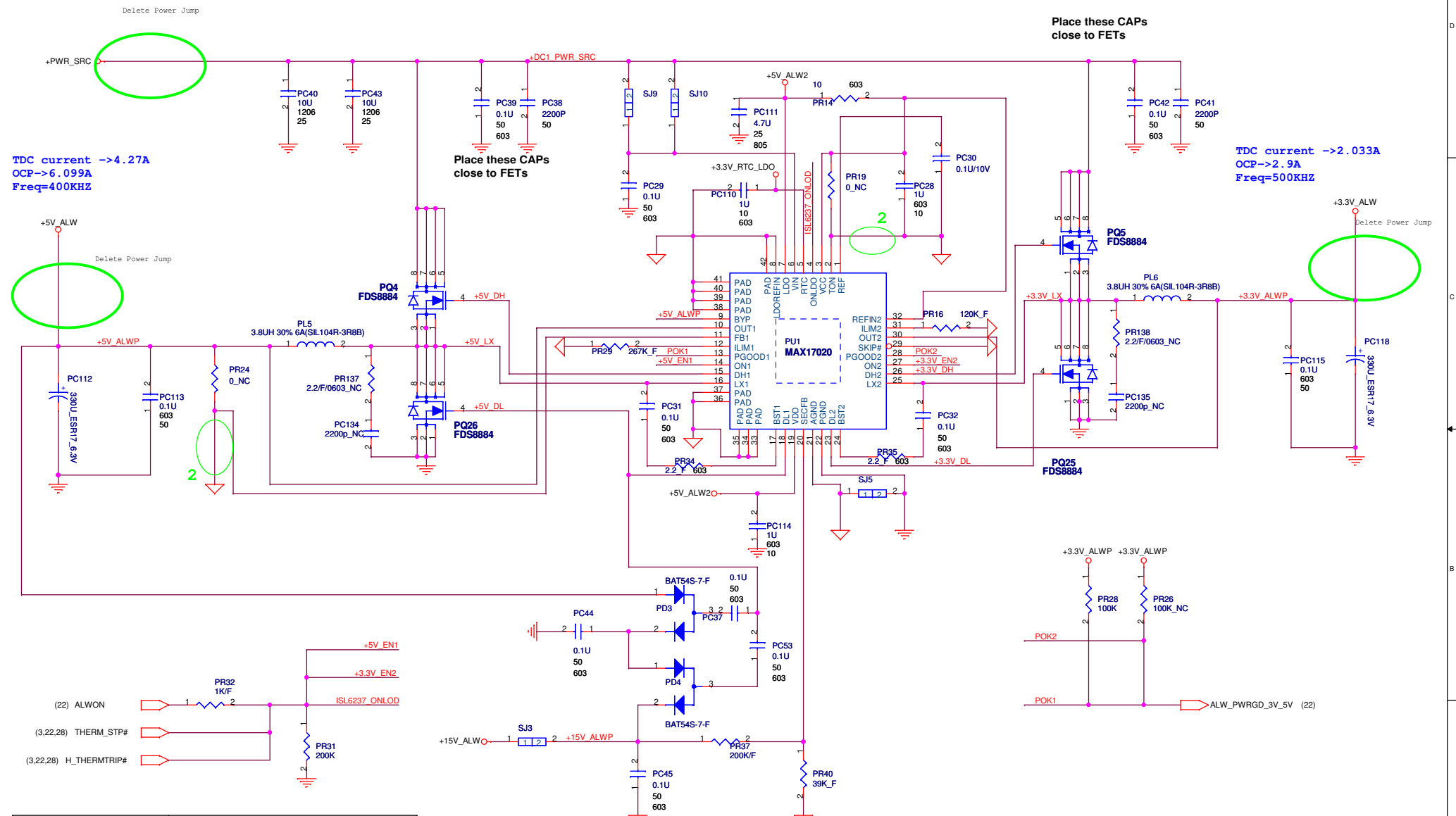

Switching regulator	TON setting
SMPS1	200KHZ (TON=VCC)
	400KHZ (TON=REF or GND)
SMPS2	300KHZ (TON=REF or VCC)
	500KHZ (TON=GND)

**QUANTA COMPUTER**

Title: 5V\_ALW, 3V\_ALW, 15V\_ALW

Size: Document Number ZM1 Rev 2B

Date: Tuesday, March 31, 2009 Sheet 39 of 46

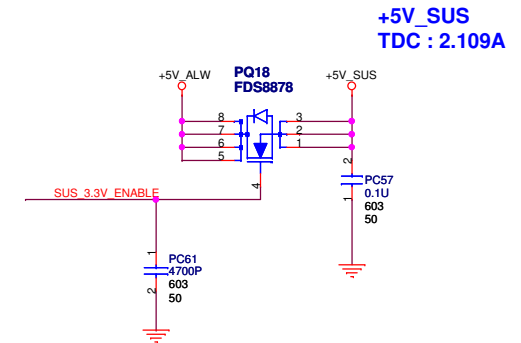
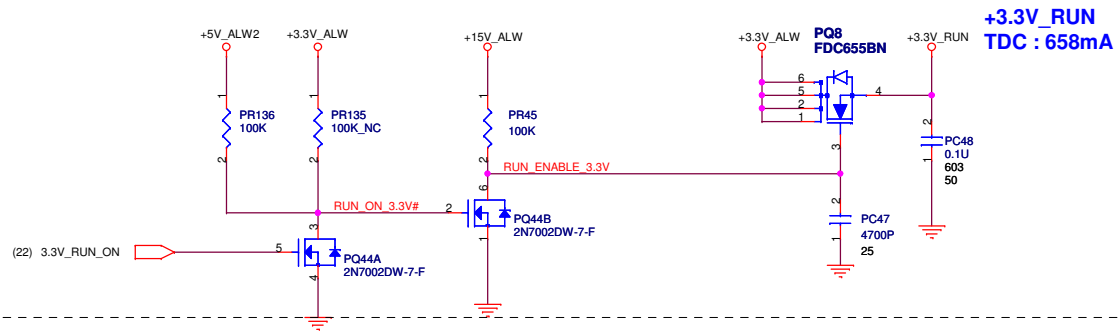
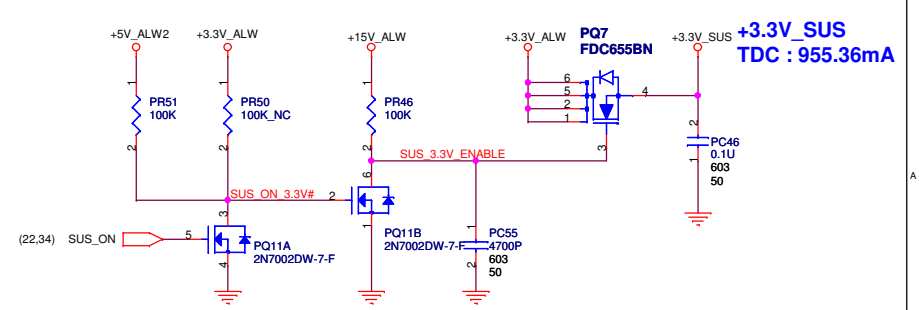
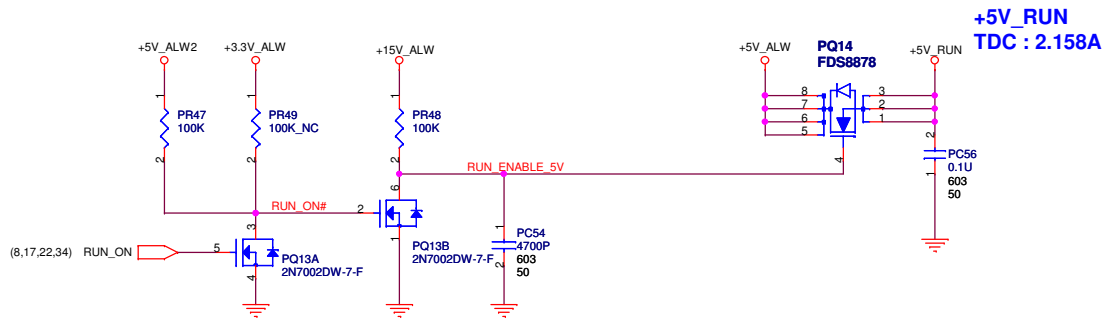

**Reserve discharge path**

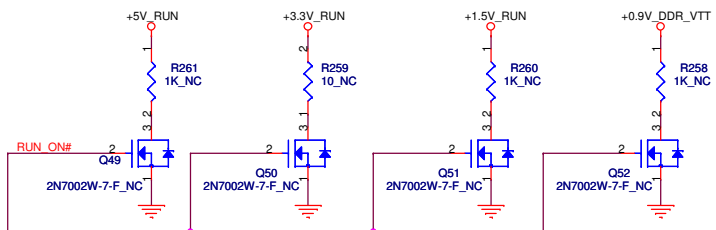

**Reserve discharge path**

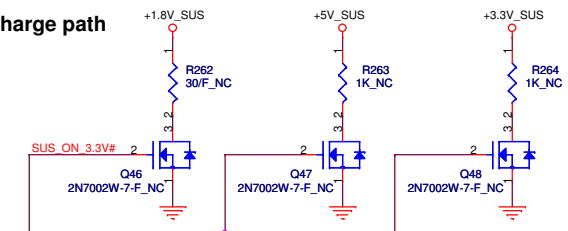

**QUANTA COMPUTER**

Title: RUN POWER SW

Size	Document Number ZM1	Rev 2B
------	------------------------	-----------

Date: Tuesday, March 31, 2009 Sheet 40 of 46



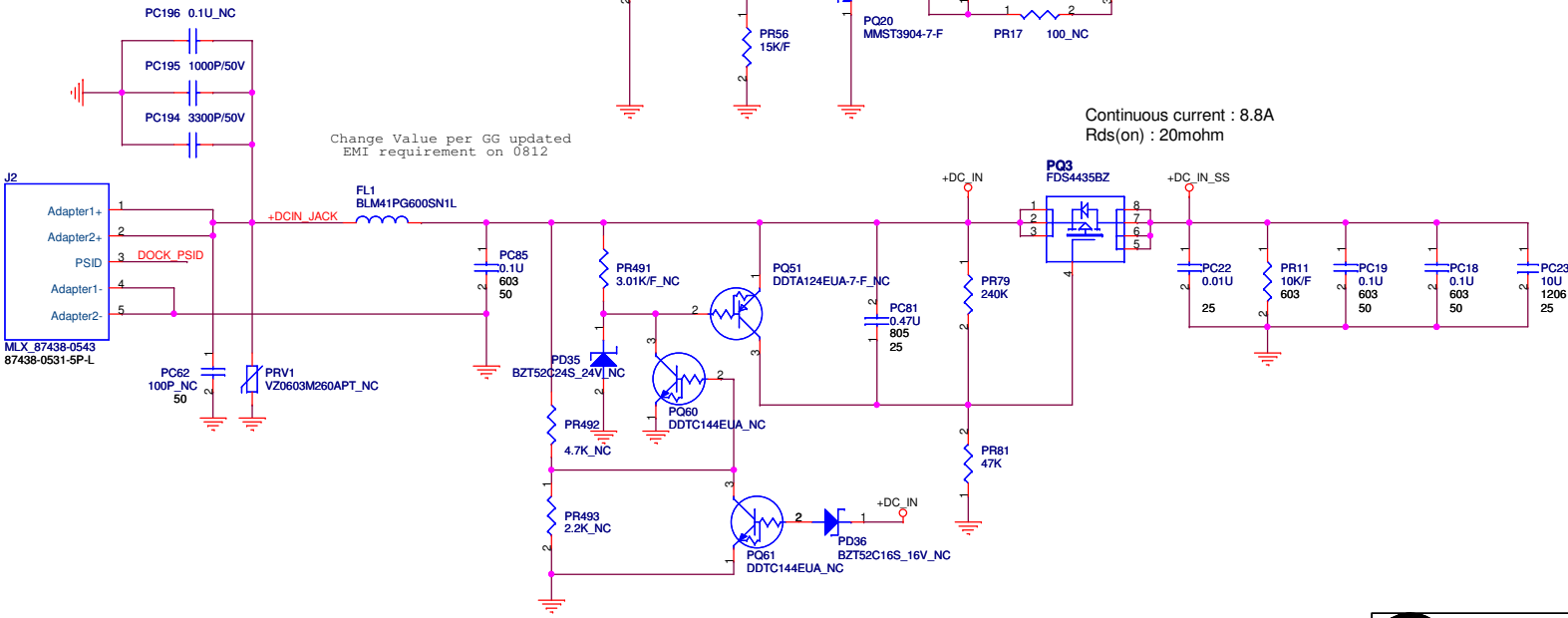
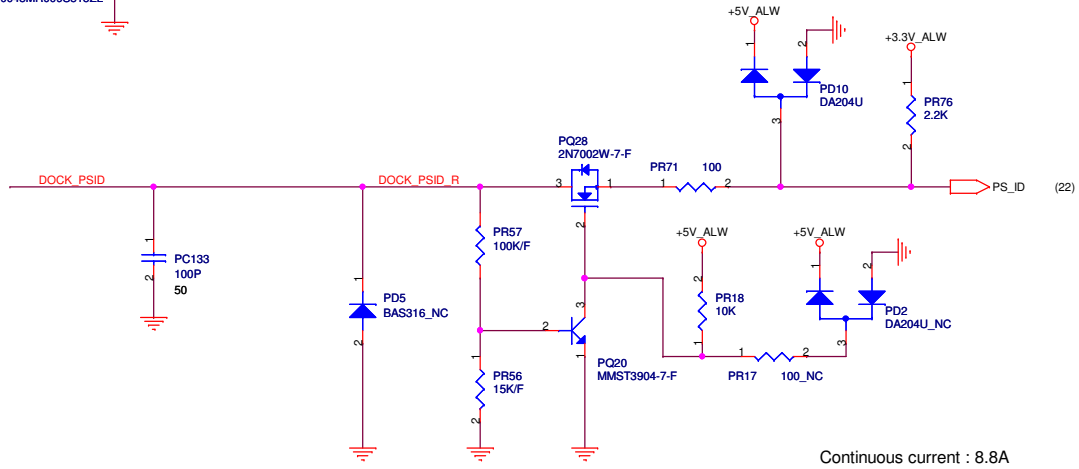
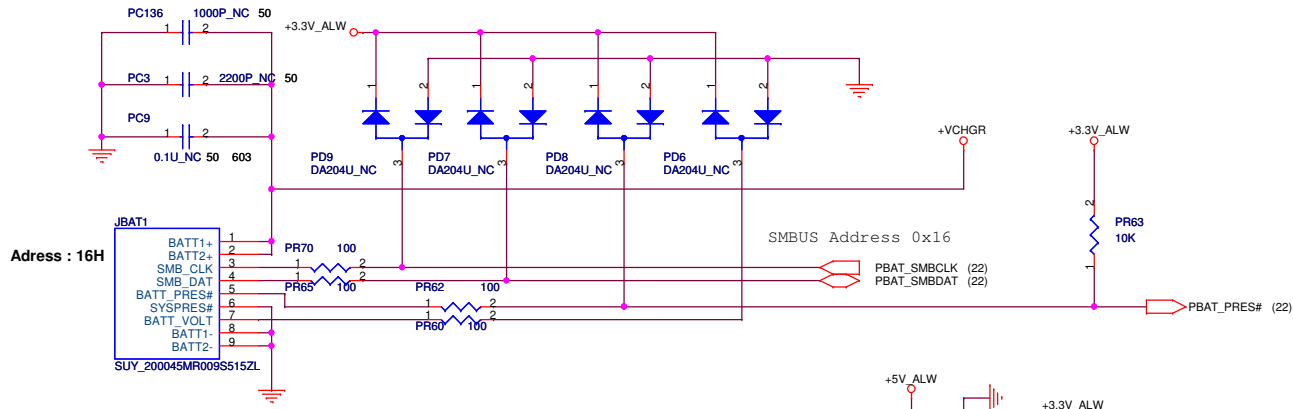

Title DCIN,BATT CONNECTOR		
Size ZM1	Document Number ZM1	Rev 2B
Date: Tuesday, March 31, 2009	Sheet 41	of 46

H-TC276BC197D157P2

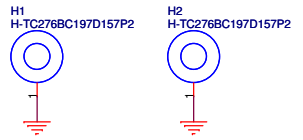

H-TC315BC236D126P2

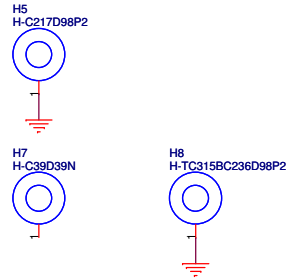

H-TC315BC256D126P2

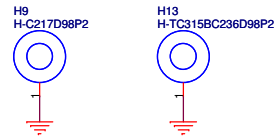

H-TC177BC197D106P2

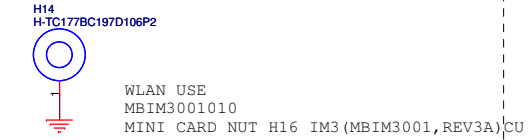

H-C315D126P2

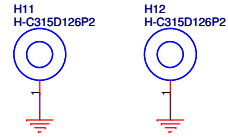

H-C157D157N

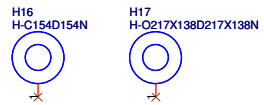

H-C236D98P2



h-tc217bc197d126p2

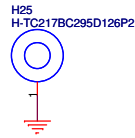

h-c118d118n

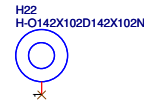

h-tc236bc217d98p2

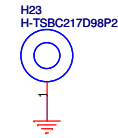

h-zm1-1

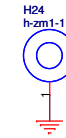

 <b>QUANTA COMPUTER</b>		
Title: SCREW PAD		
Size:	Document Number: ZM1	Rev: 2B
Date:	Tuesday, March 31, 2009	Sheet: 42 of 46

Reserved for EMI.

### Stitching caps.

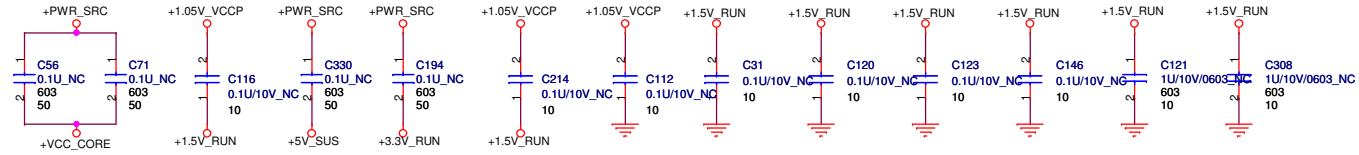
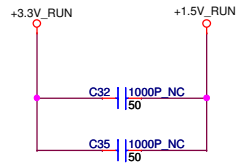

### Stitching caps for PCI bus.

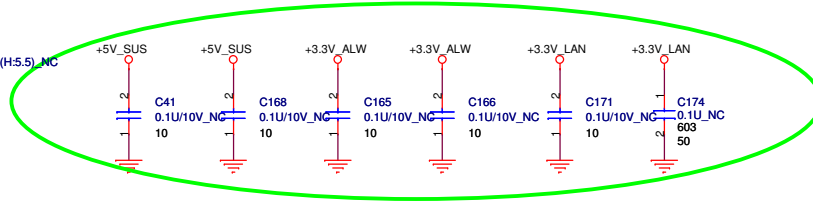
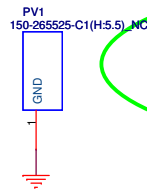
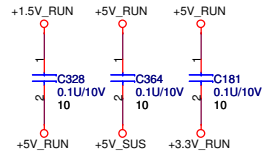

Add cap near LAN

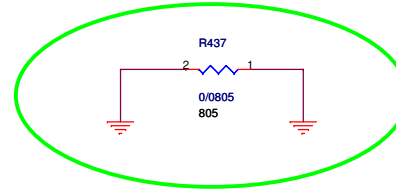
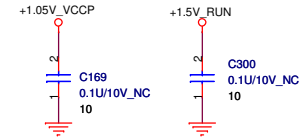

Add GND to GND for LAN GND

**ICH7-M**

**SIO  
ECE5035**

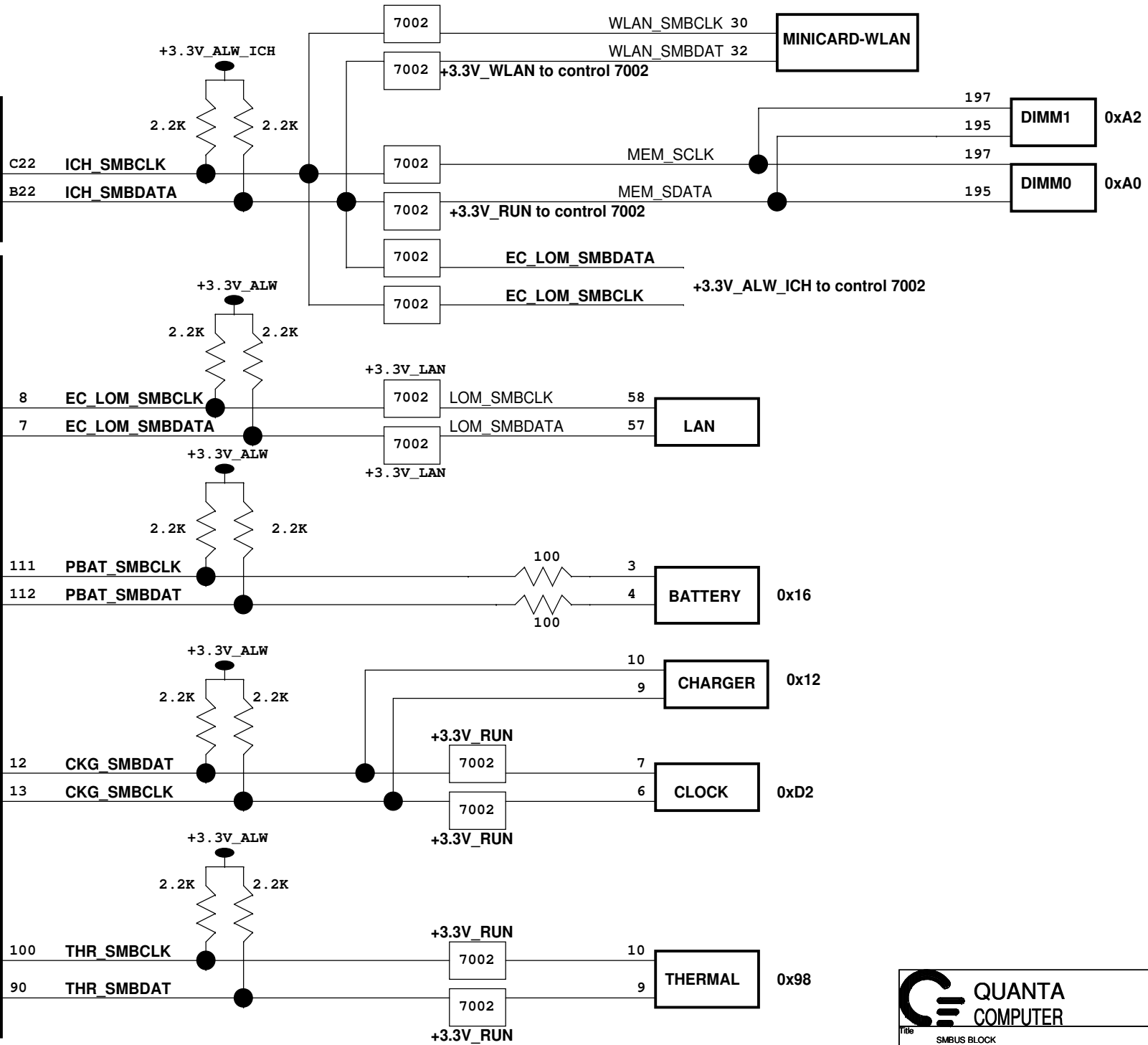

VER : 1A

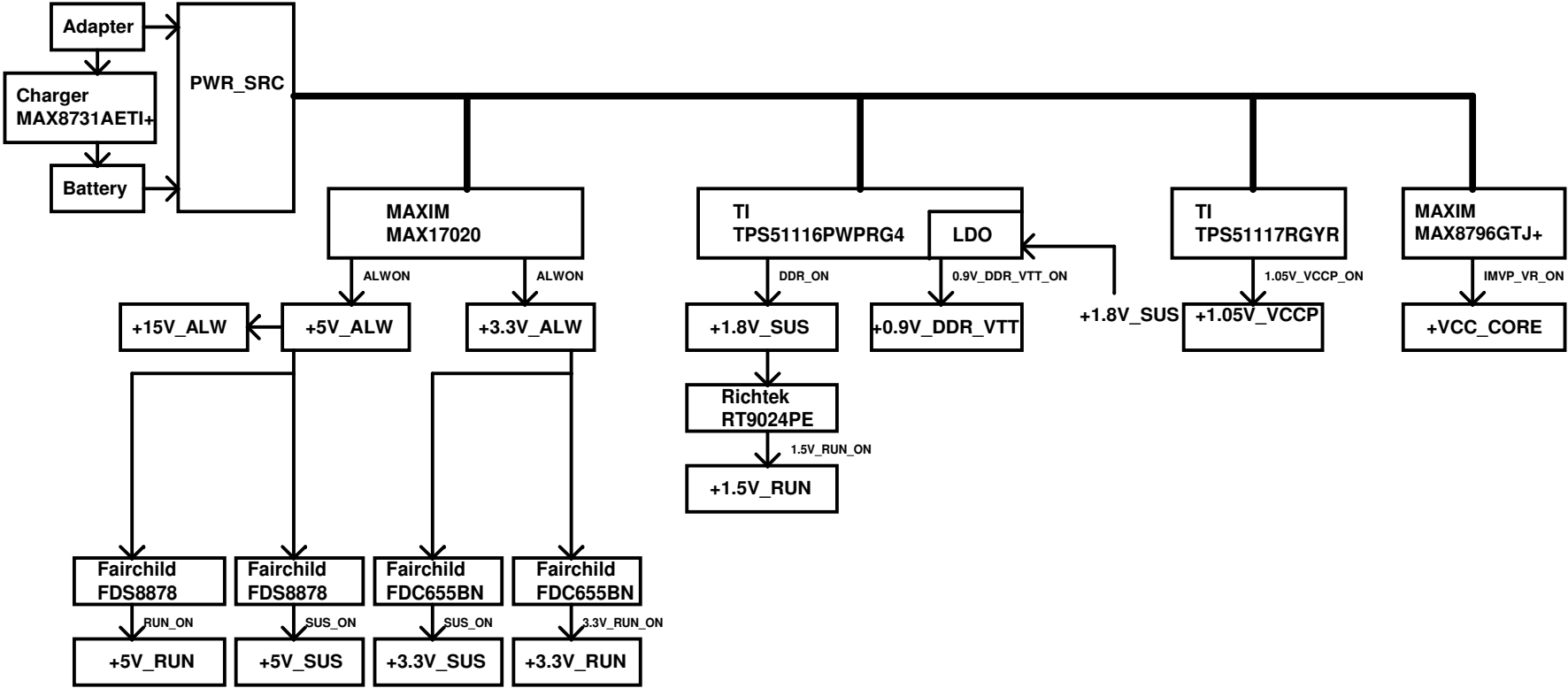

ICH USB	Device
USBP0	Right side top
USBP1	Right side bottom
USBP2	Left side
USBP3	Card Reader
USBP4	Camera
USBP5	Touch Screen
USBP6	Bluetooth
USBP7	WLAN

PCI-E	Device
PCIE-1	NC
PCIE-2	Mini WLAN
PCIE-3	NC
PCIE-4	LAN
PCIE-5	NC
PCIE-6	NC

SATA	Device
SATA0	SATA/SSD HDD
SATA1	NC

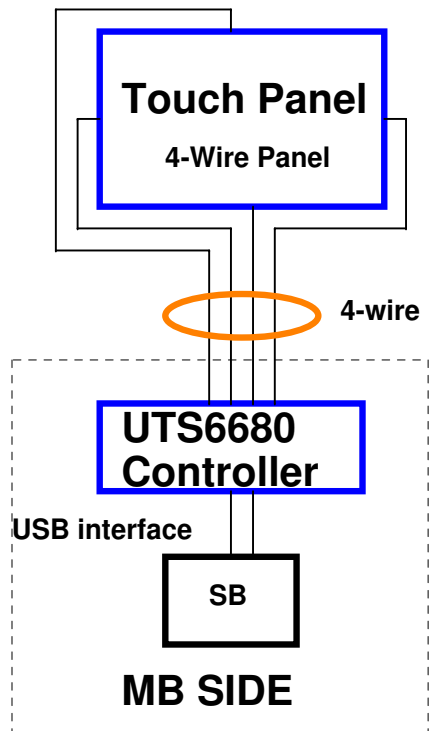

AL006680B00IC OTHER(32P) UTS6680EF (LQFP)



Title		
Port Mapping		
Size	Document Number	Rev
	ZM1	3A
Date:	Tuesday, March 31, 2009	Sheet 46 of 46