

KV2 Block Diagram

<http://hobi-elektronika.net>

01

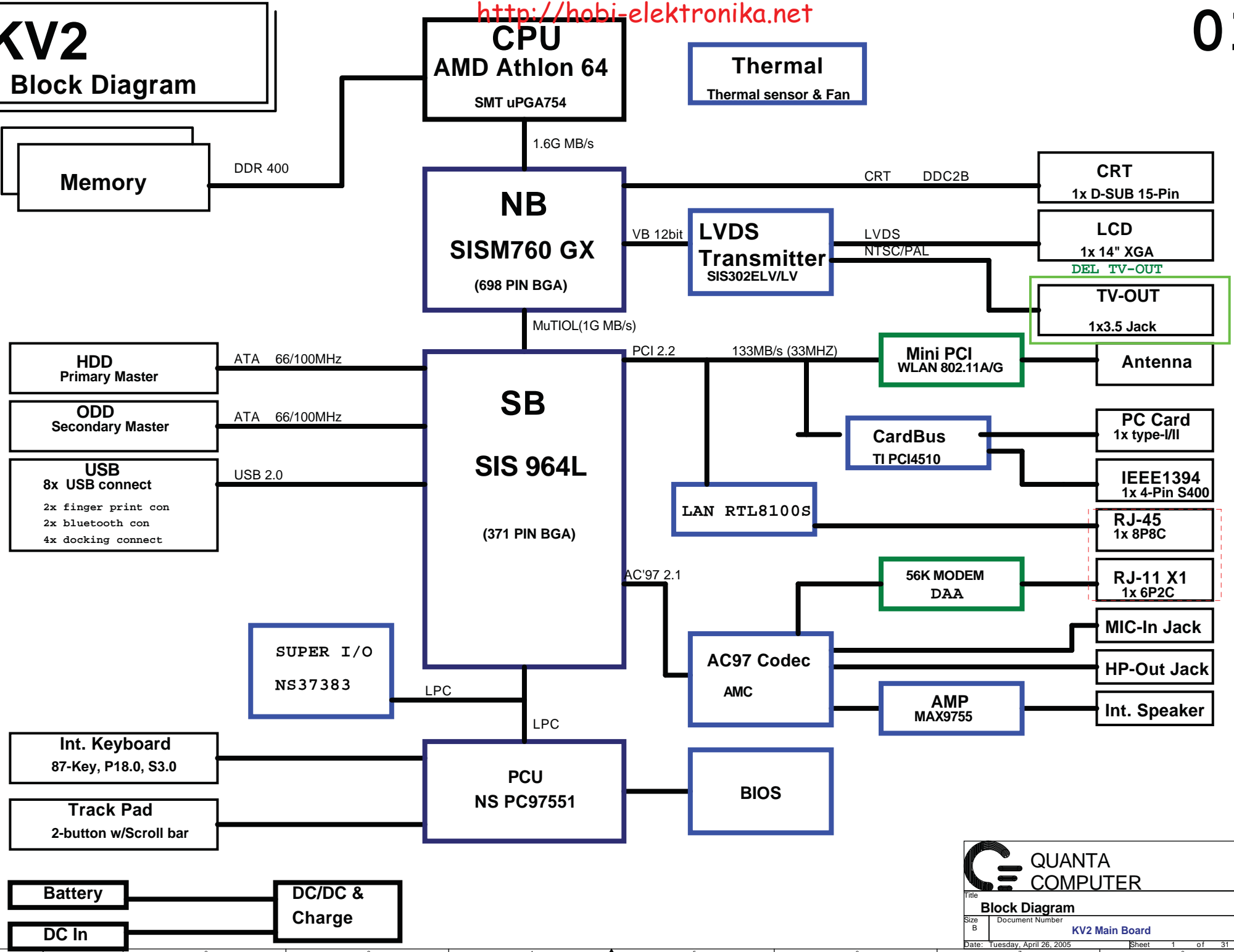

QUANTA COMPUTER

Title: **Block Diagram**

Size B	Document Number	Rev A
	KV2 Main Board	

Date: Tuesday, April 26, 2005 Sheet 1 of 31

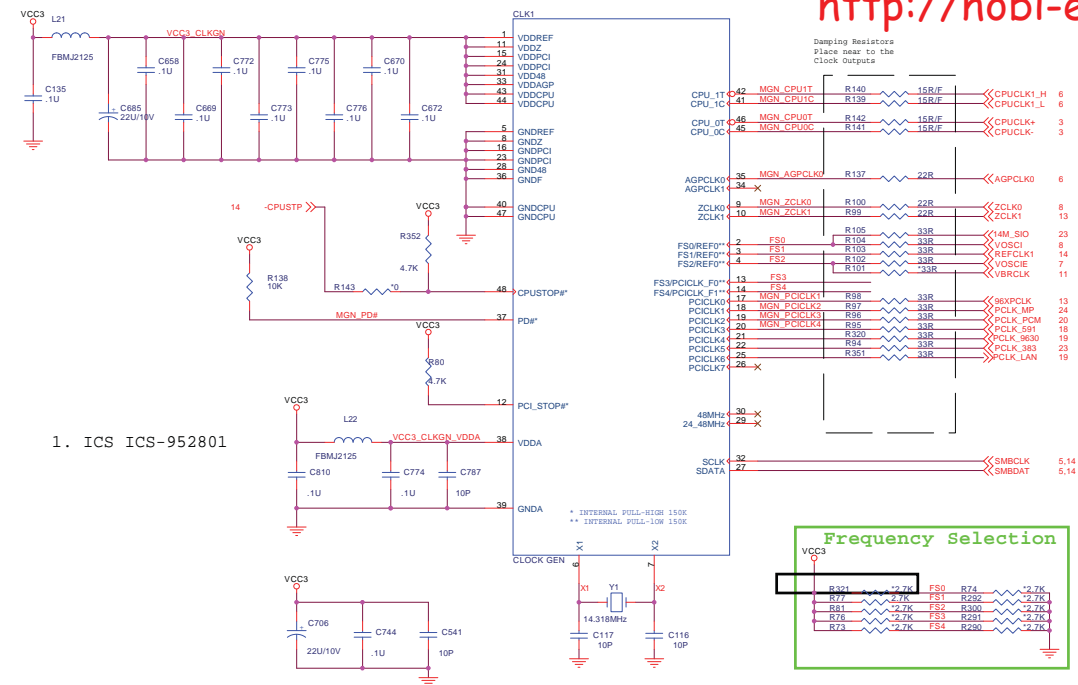

1. ICS ICS-952801

CLK Table for SiS M760 (Not For ICS ICS-952801)

SiS 755/M760 CLOCK										SiS 755/M760 CLOCK									
(FS4)	(FS3)	(FS2)	(FS1)	(FS0)	CPU	ZCLK	AGPCLK	PCI	VCO	(FS4)	(FS3)	(FS2)	(FS1)	(FS0)	CPU	ZCLK	AGPCLK	PCI	VCO
					(MHz)	(MHz)	(MHz)	(MHz)	(MHz)						(MHz)	(MHz)	(MHz)	(MHz)	(MHz)
0	0	0	0	0	200	66.66	66.66	33.33	400	1	0	0	0	0	188	132.14	66.07	33.04	188
0	0	0	0	1	200	133.33	66.66	33.33	400	1	0	0	1	0	190	135.71	67.08	33.53	190
0	0	0	1	1	200	166.66	66.66	33.33	1000	1	0	0	1	1	195	130	65	32.5	195
0	0	1	0	0	233	66.66	66.66	33.33	466	1	0	1	0	0	205	136.66	68.33	34.17	205
0	0	1	0	1	233	93.2	66.66	33.33	466	1	0	1	0	1	210	140	70	35	210
0	0	1	1	0	233	133.28	66.64	33.33	933	1	0	1	1	0	215	129	64.5	32.25	215
0	0	1	1	1	233	139.8	69.9	33.33	699	1	0	1	1	1	220	132	66	33	220
0	1	0	0	0	266	66.66	66.66	33.33	266	1	1	0	0	0	66.66	66.66	66.66	33.33	66.66
0	1	0	0	1	266	106.4	66.5	33.33	532	1	1	0	0	1	66.66	100	66.66	33.33	66.66
0	1	0	1	0	266	133	66.5	33.33	532	1	1	0	1	0	100	100	66.66	33.33	100
0	1	0	1	1	266	159.6	66.5	33.33	798	1	1	0	1	1	100	133.33	66.66	33.33	100
0	1	1	0	0	200	133	50	33.33	400	1	1	1	0	0	133	100	66.66	33.33	133
0	1	1	0	1	200	114	66.66	33.33	800	1	1	1	0	1	133	133.33	66.66	33.33	133
0	1	1	1	0	200	142	66.66	33.33	1000	1	1	1	1	0	166	100	66.66	33.33	166
0	1	1	1	1	200	160	66.66	33.33	800	1	1	1	1	1	166	133.33	66.66	33.33	166

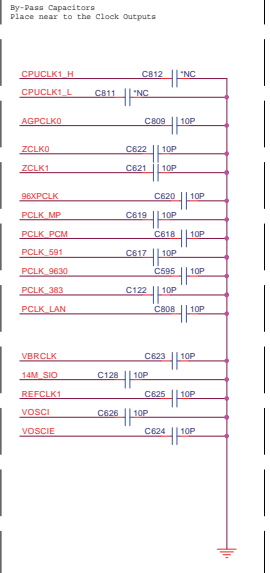

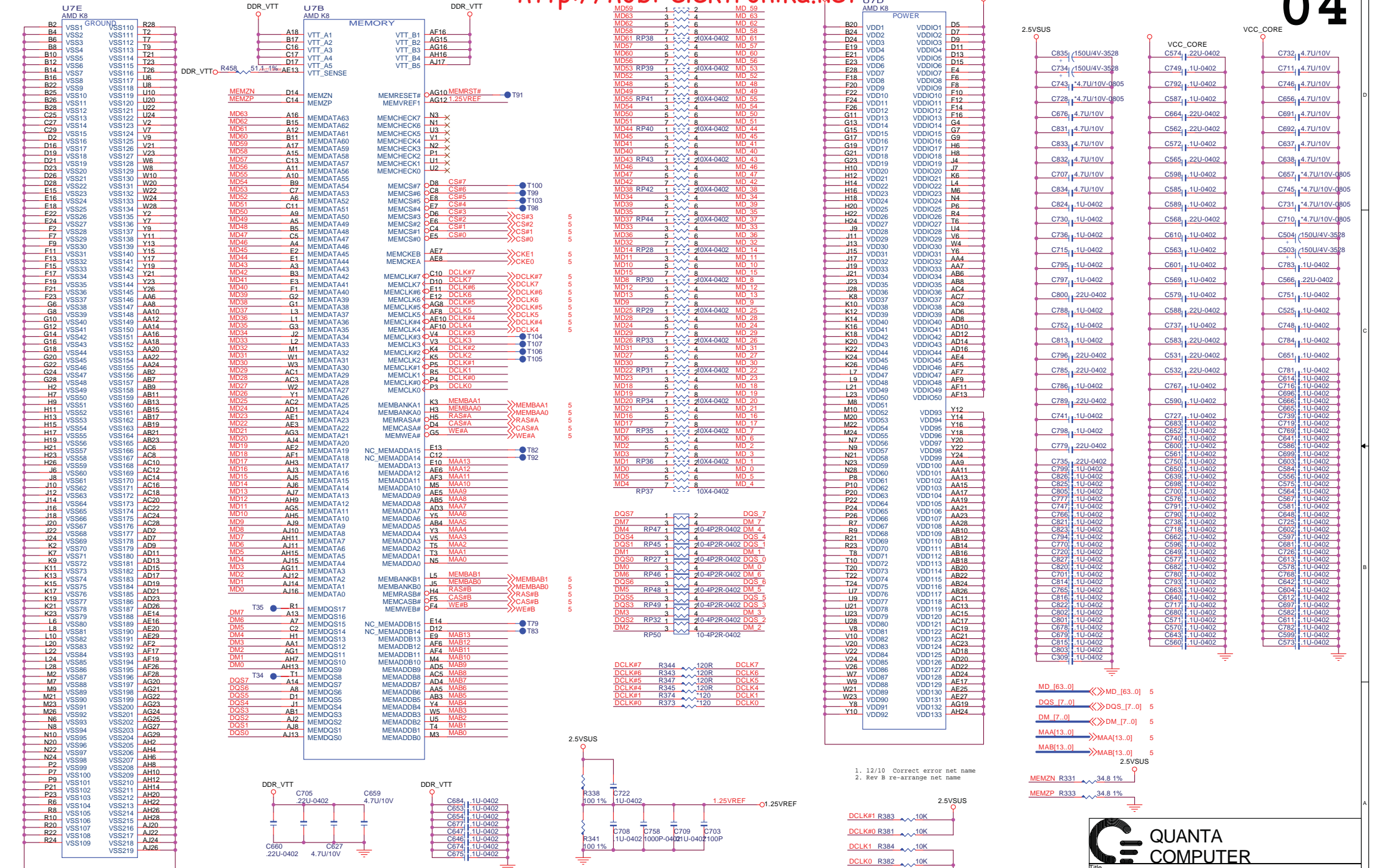

1. 12/10 Correct error net name
2. Rev B re-arrange net name



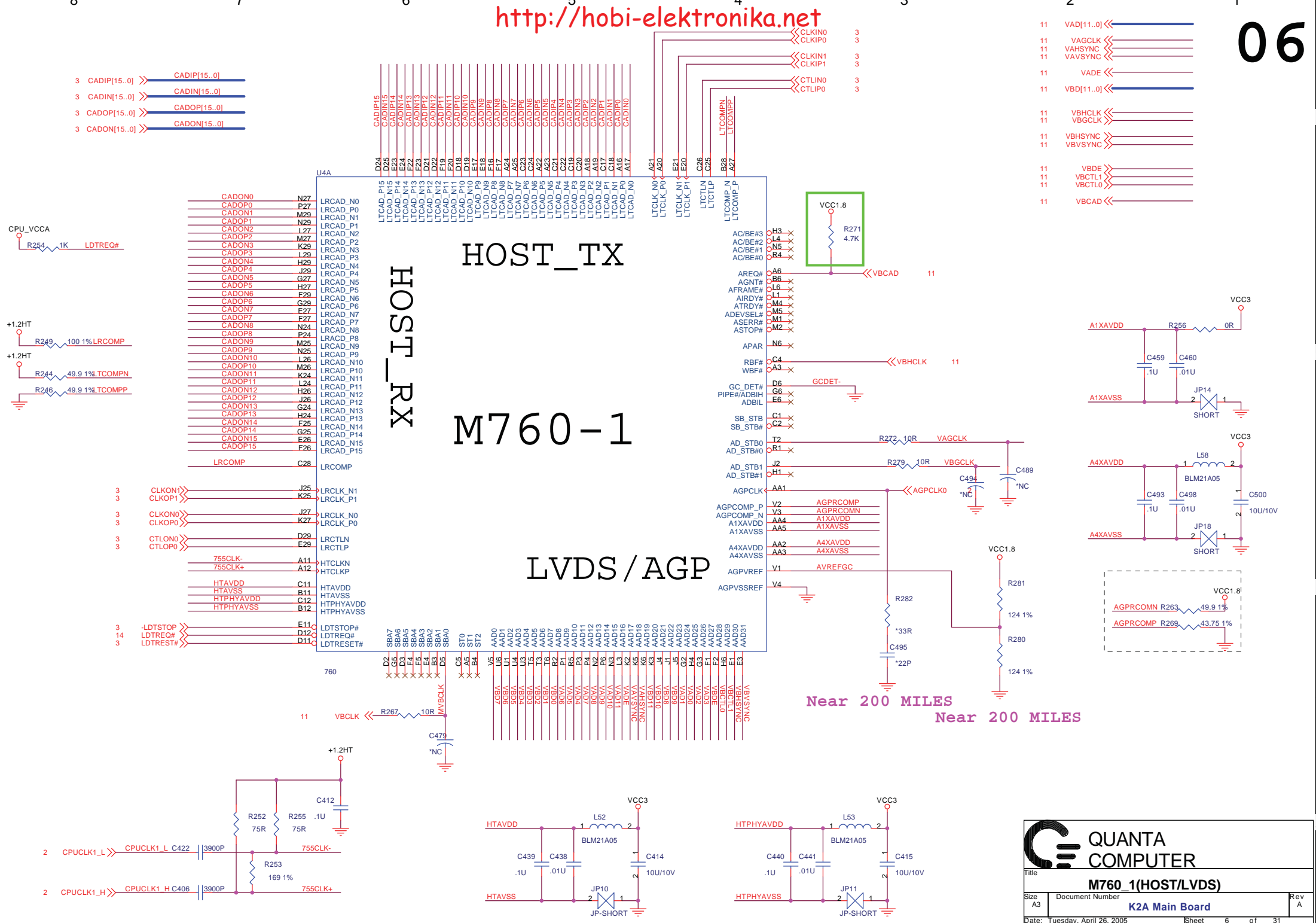

QUANTA COMPUTER

Title: **M760_1(HOST/LVDS)**

Size A3 | Document Number: **K2A Main Board** | Rev A

Date: Tuesday, April 26, 2005 | Sheet 6 of 31

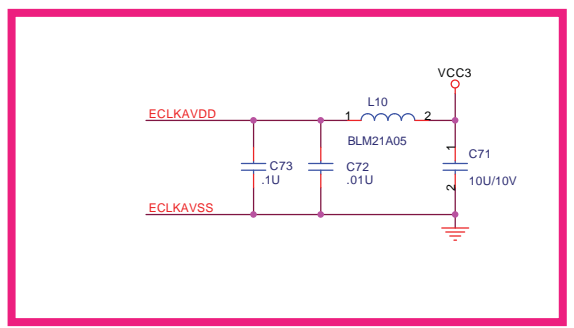
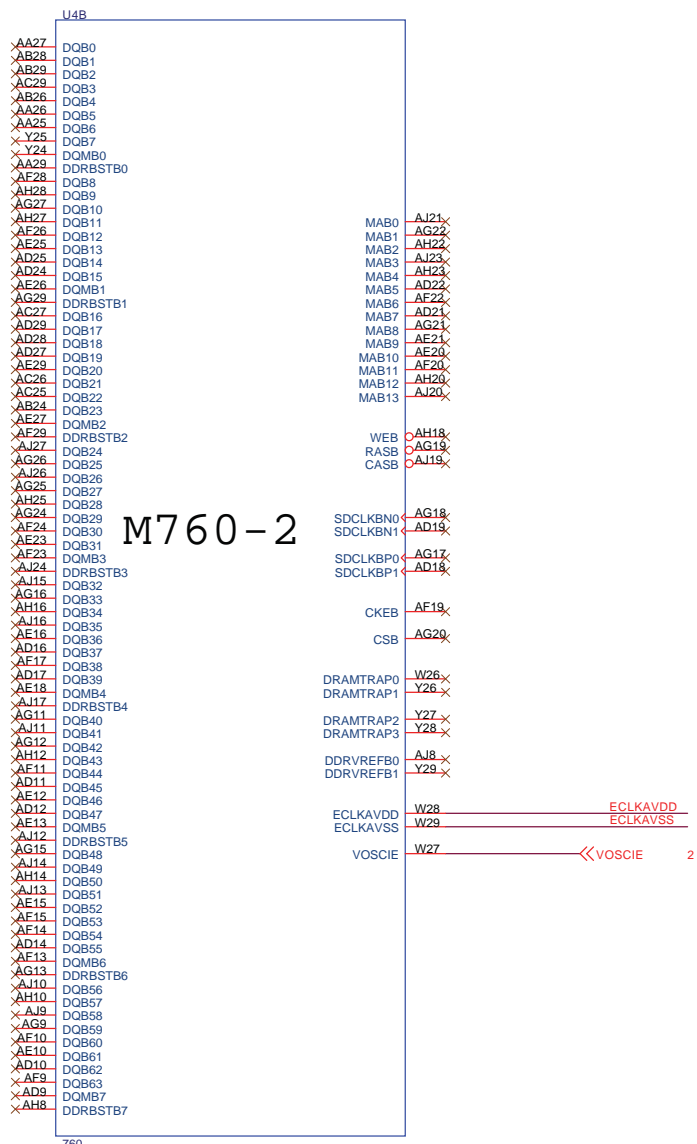

Place near the
Local Frame Buffer

They can be remove for SiS M760 without Local Frame Buffer.

QUANTA COMPUTER

Title: **M760_2(Memory For Frame Buffer)**

Size: A3	Document Number: K2A Main Board	Rev: A
Date: Tuesday, April 26, 2005	Sheet: 7	of 31

The differences between the traces of MuTIOL Strokes and Data in each group should be smaller than 0.05", and strokes need guide GND trace

Near 200 MILES

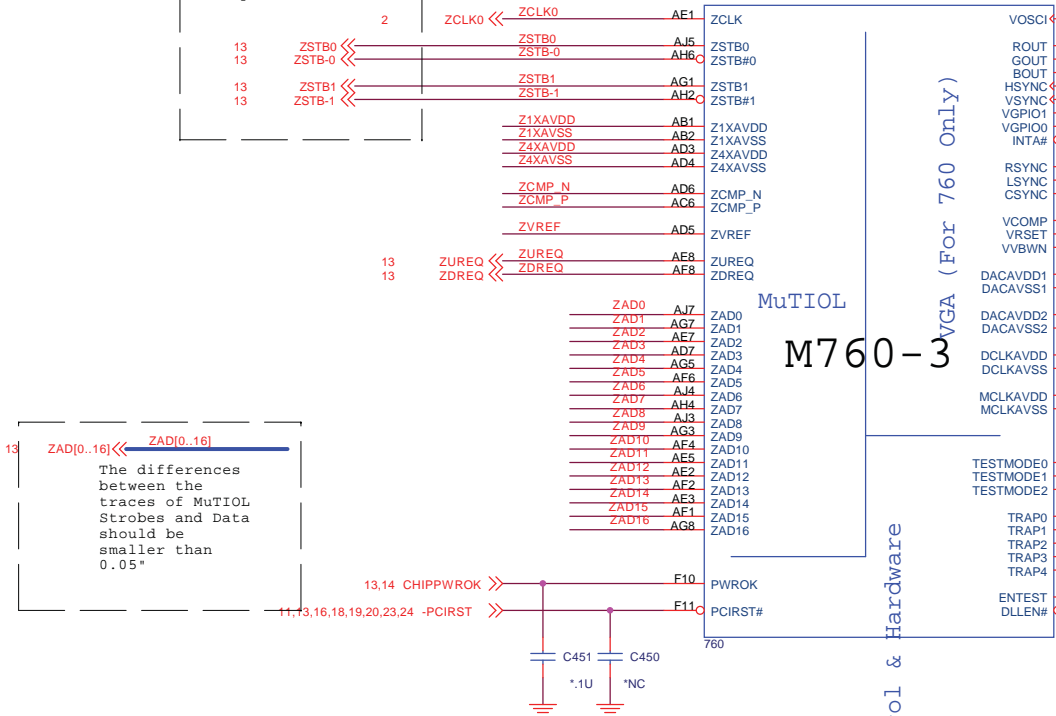

TRACE WIDTH = 10~14 MILES

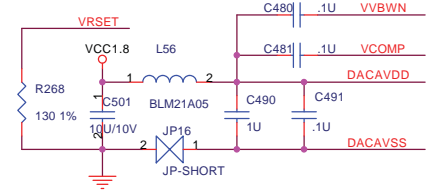
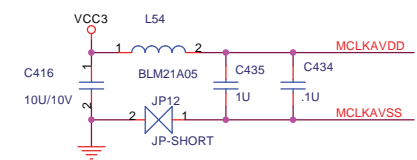
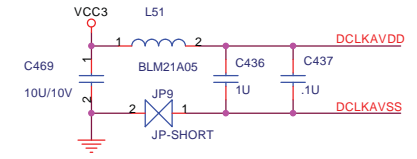
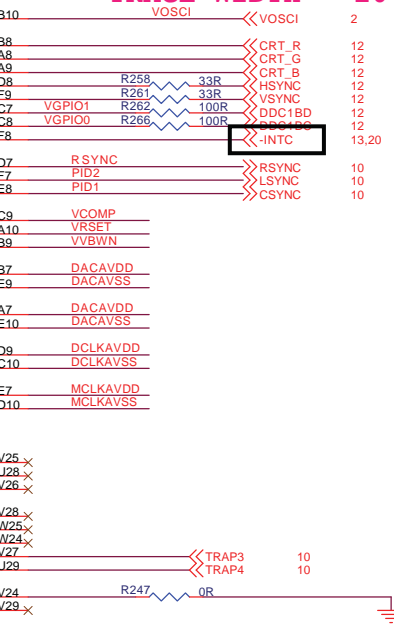

The differences between the traces of MuTIOL Strokes and Data should be smaller than 0.05"

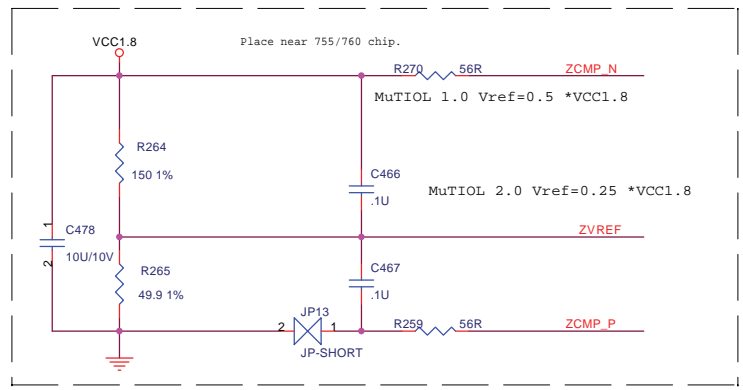
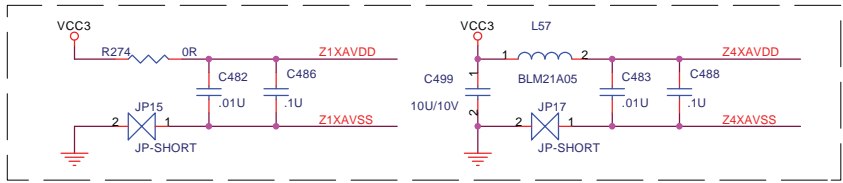

If Support Sis M760LV IVDD=1.5V

use Sis M760 without Local Frame Buffer.

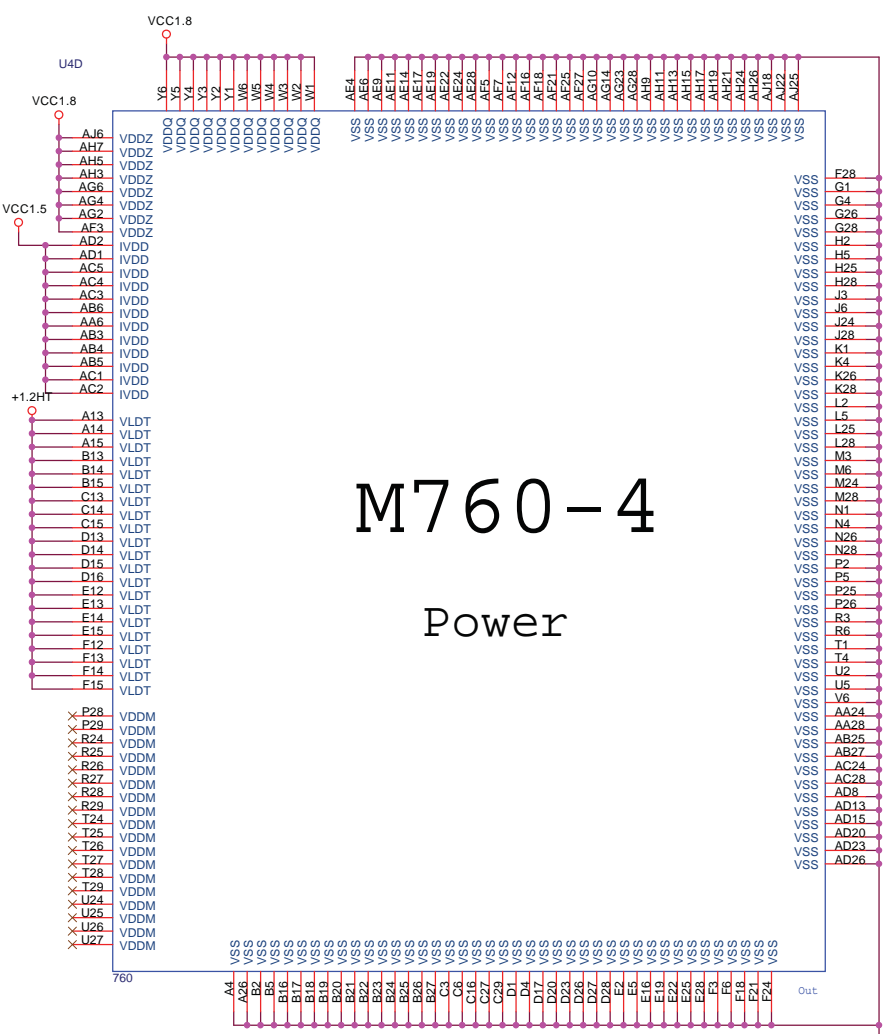

M760-4 Power

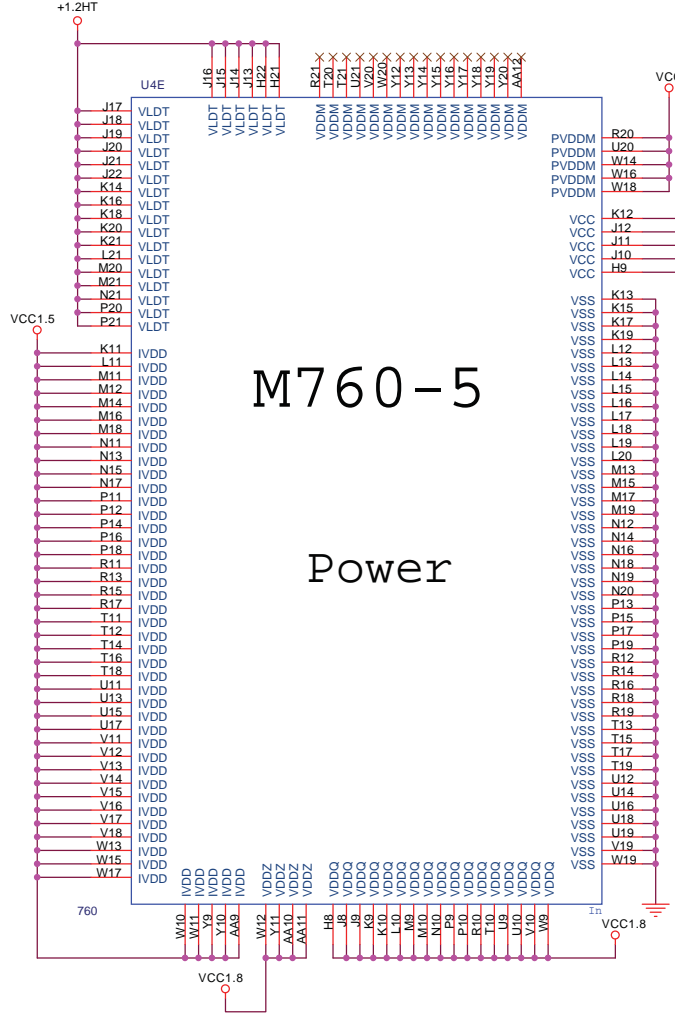

M760-5 Power

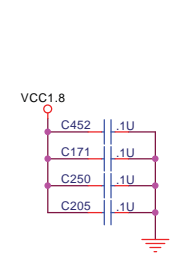
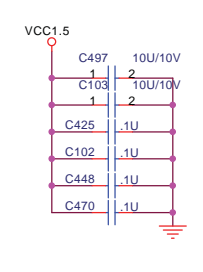
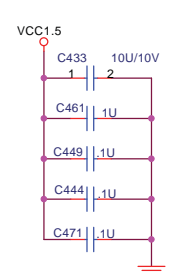
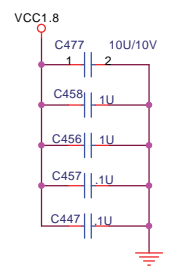
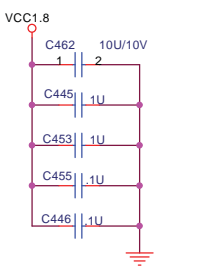
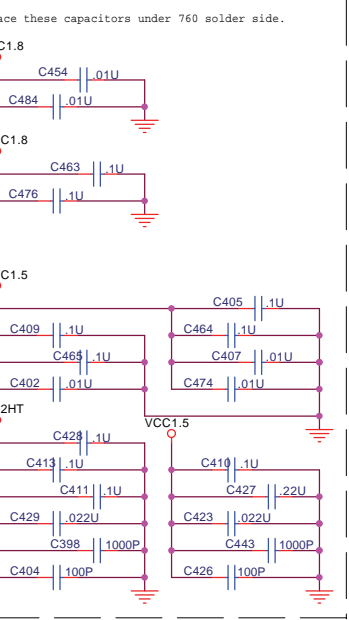
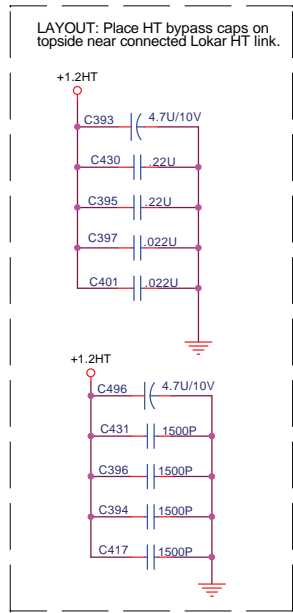

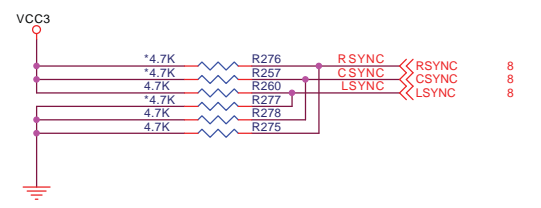
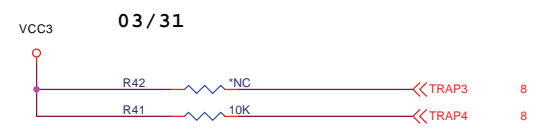

SIS755/760 NB Hardware Trap Table

		755/760	ON/1	OFF/0	Internal	Default
DLEN#	CPUCLK/ZCLK/AGPCLK PLL/DLL Circuit Enable		DISABLE	ENABLE	Pull Low	Low/0
TESTMODE0					Pull Low	
TESTMODE1	755 Test Mode Selection		1: Model	0: Mode0	Pull Low	
TESTMODE2	755 Test Mode Enable		ENABLE	DISABLE	Pull Low	Low/0
TRAP0	MuTIOL Verision 1 , 2		Ver. 1	Ver. 2	Pull Low	Low/0
TRAP1	MuTIOL DBI Mode		DISABLE	ENABLE	Pull Low	Low/0
TRAP2	MuTIOLIntial Packet Series Mode		DISABLE	ENABLE	Pull Low	Low/0
TRAP3	Reserve				Pull Low	High/1
TRAP4	Reserve				Pull Low	High/1

S-video

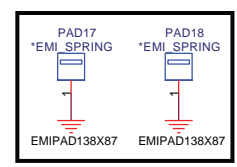
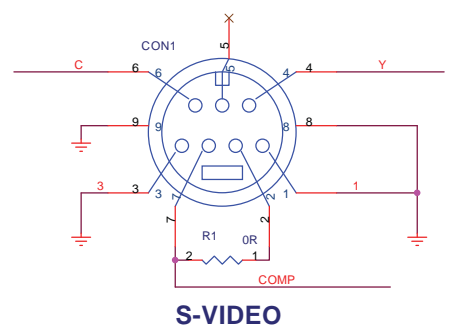
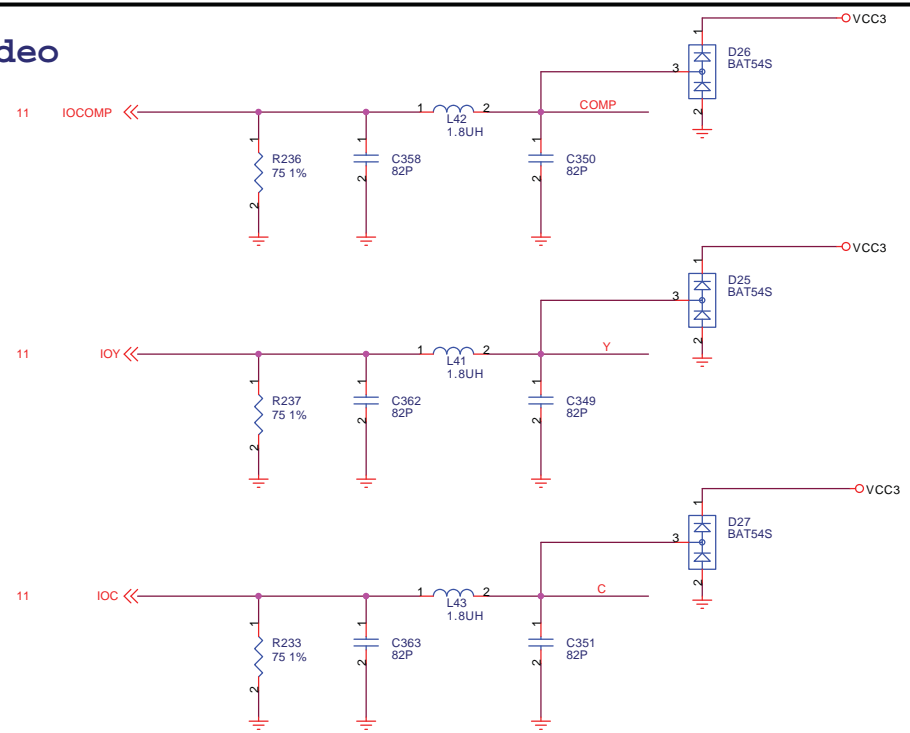

QUANTA COMPUTER

Title: **Hardware Trap & TV-OUT**

Size B | Document Number: **KV2 Main Board** | Rev A

Date: Tuesday, April 26, 2005 | Sheet 10 of 31

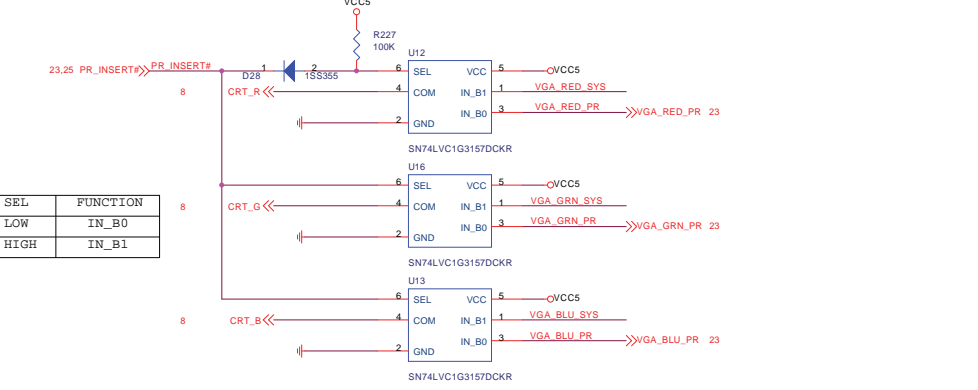
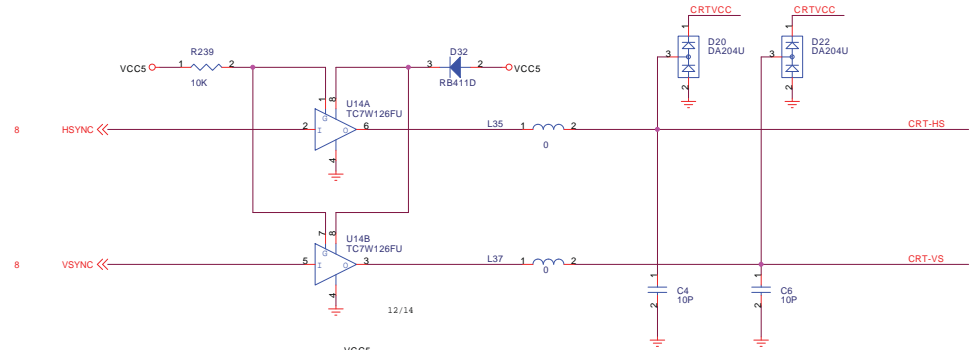
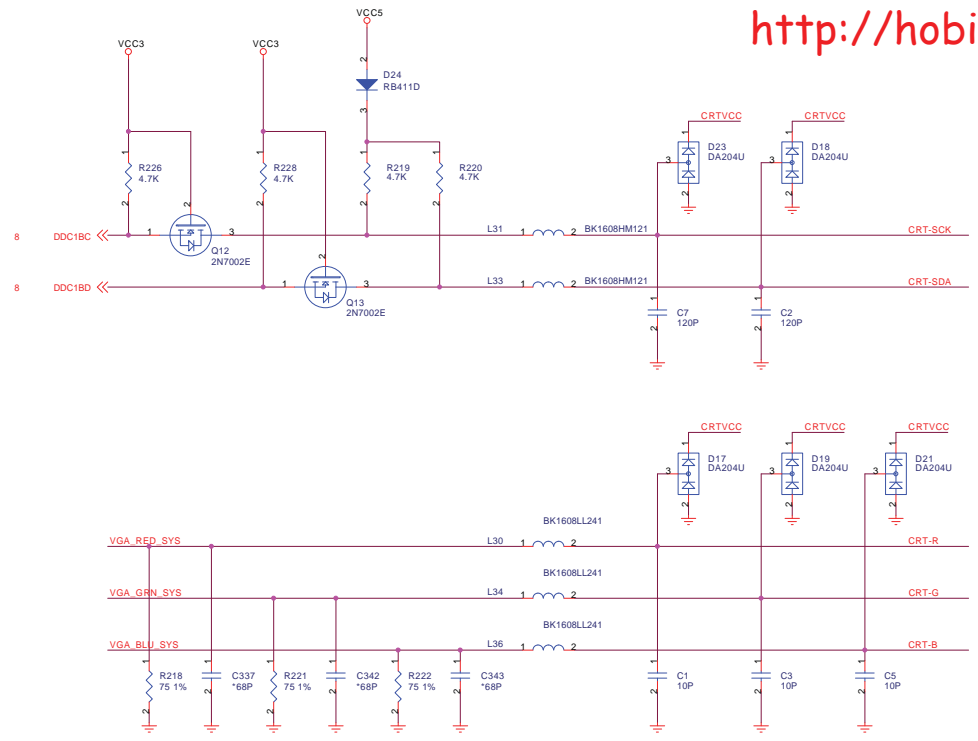

SEL	FUNCTION
LOW	IN_B0
HIGH	IN_B1

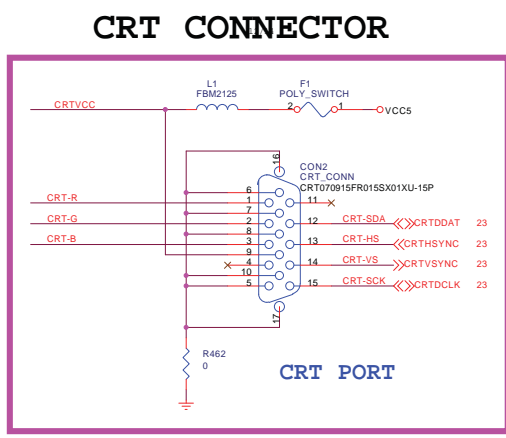
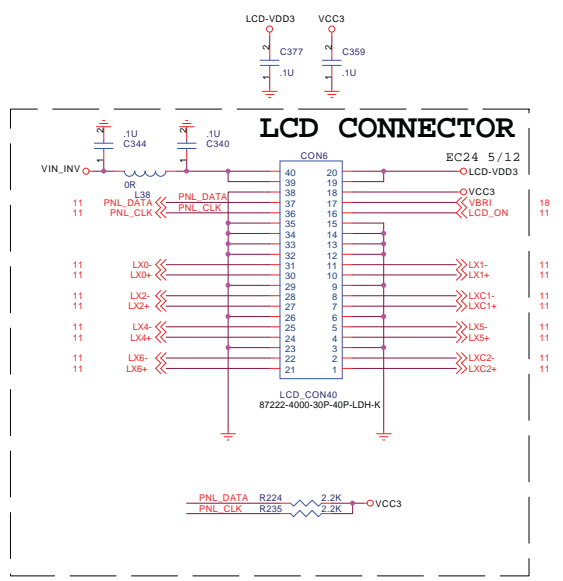

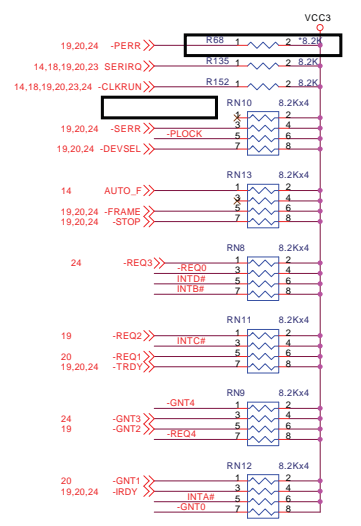
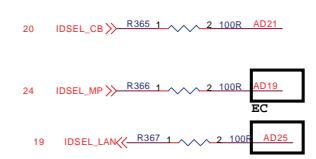
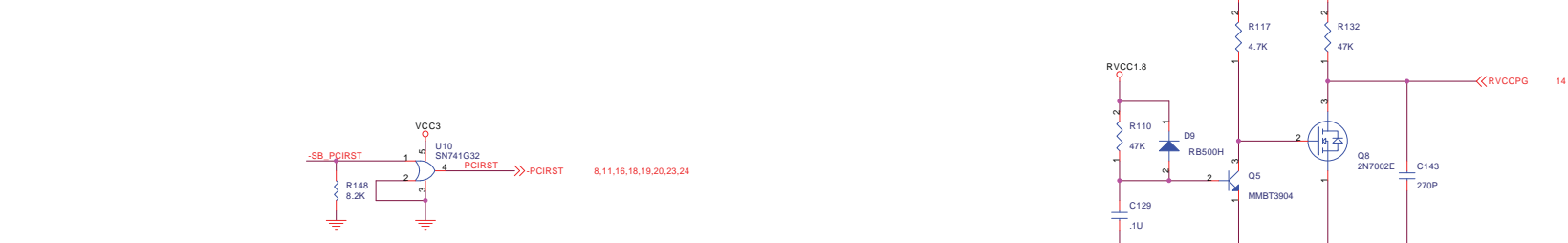
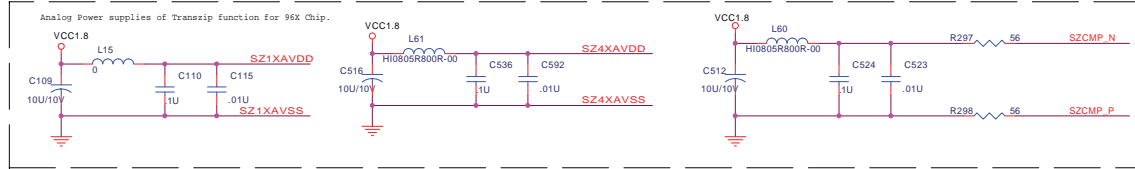
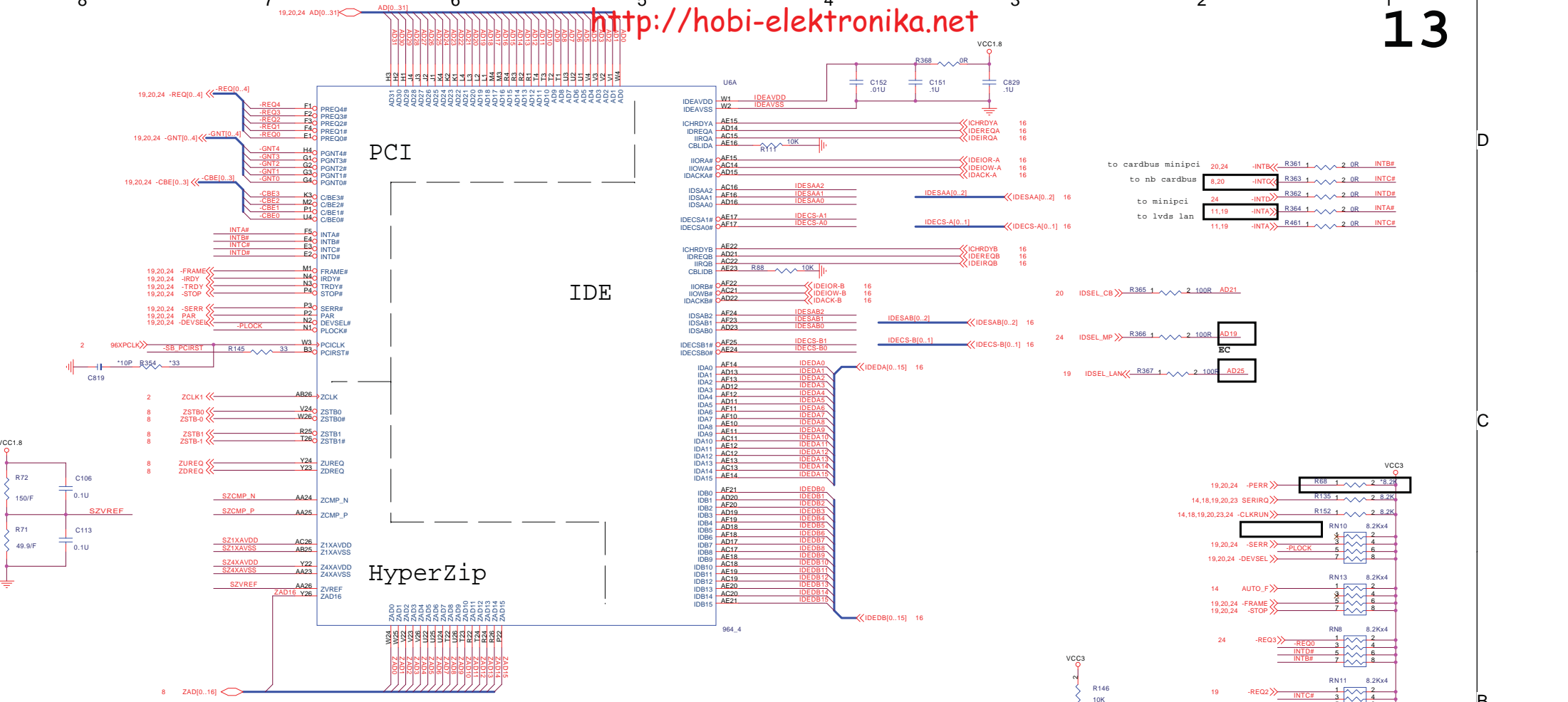

Near 200 MILES

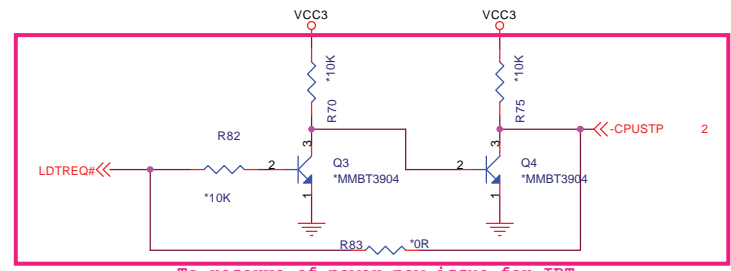
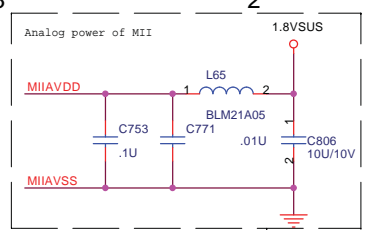
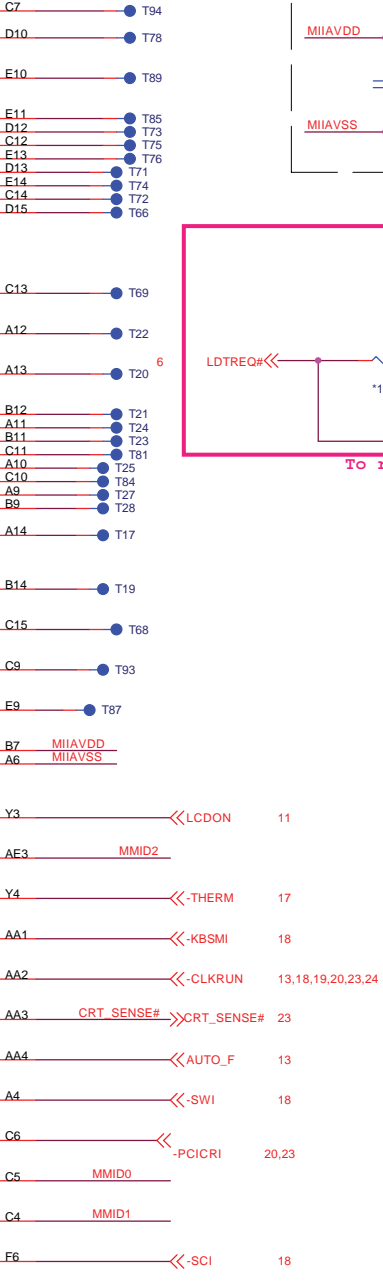
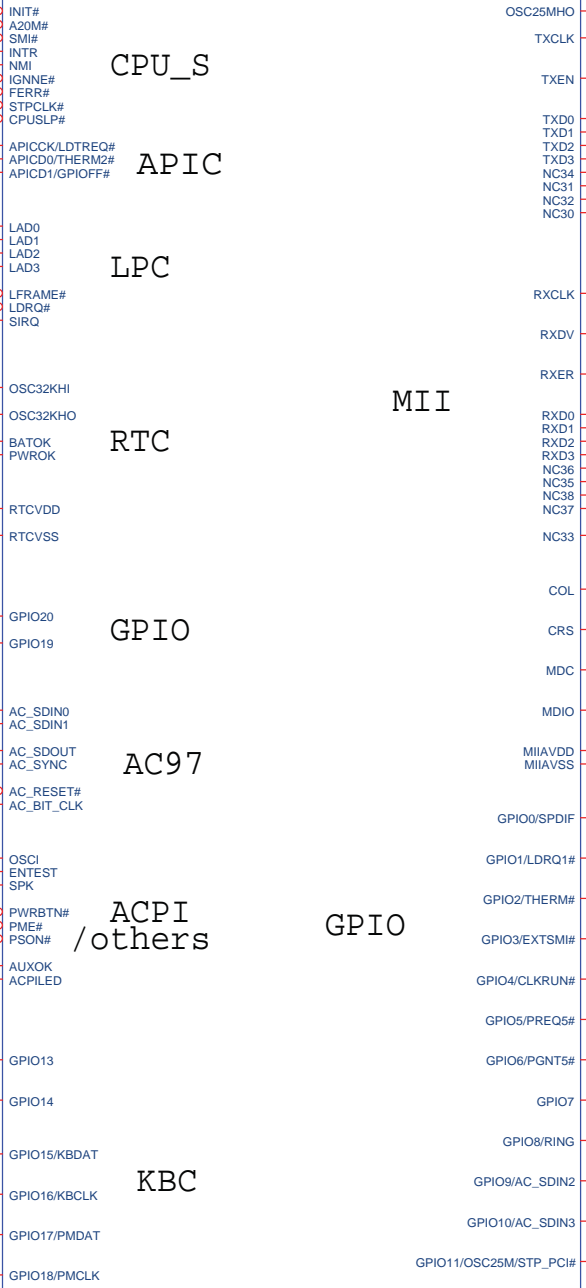
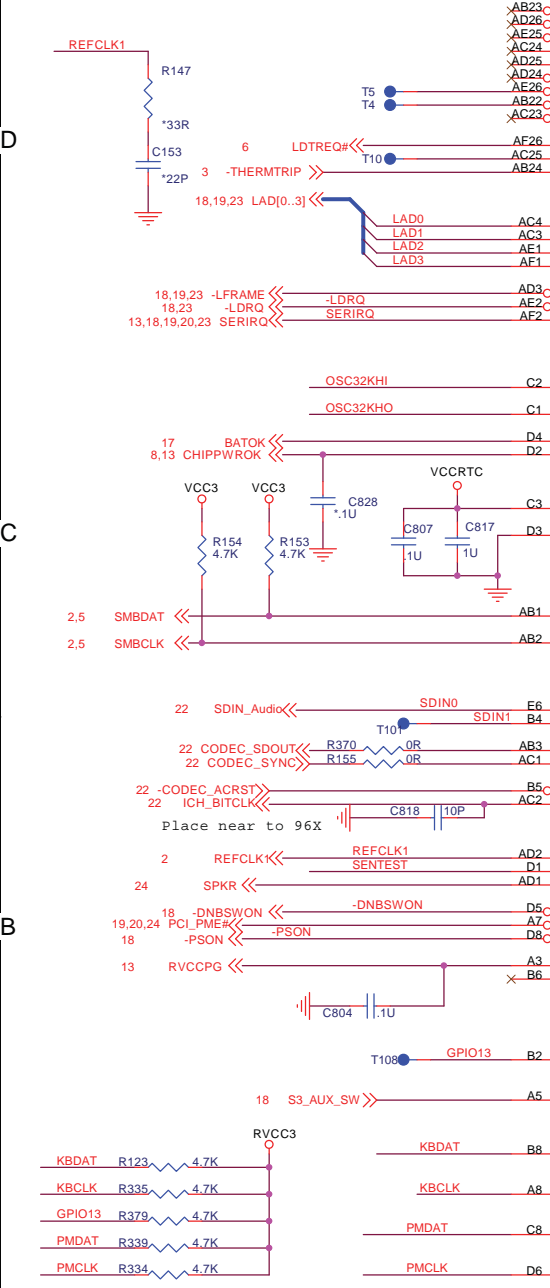

To reserve of power now issue for IRT



On board Memory ID

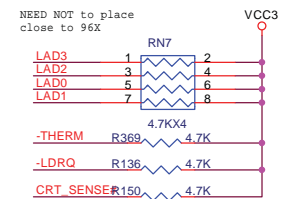
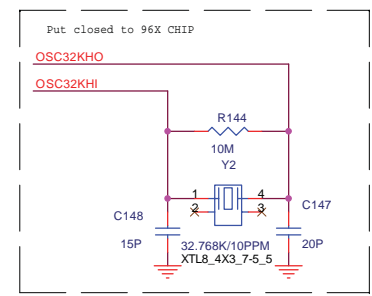

S15963, 964 GPIO 0-7 internal pull up
 S15963, 964 GPIO 9,10 internal pull down

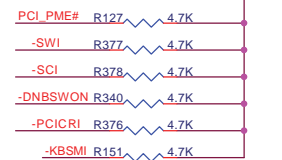
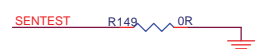
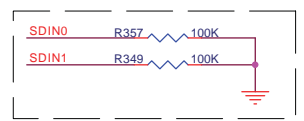
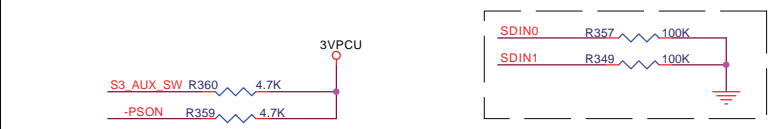

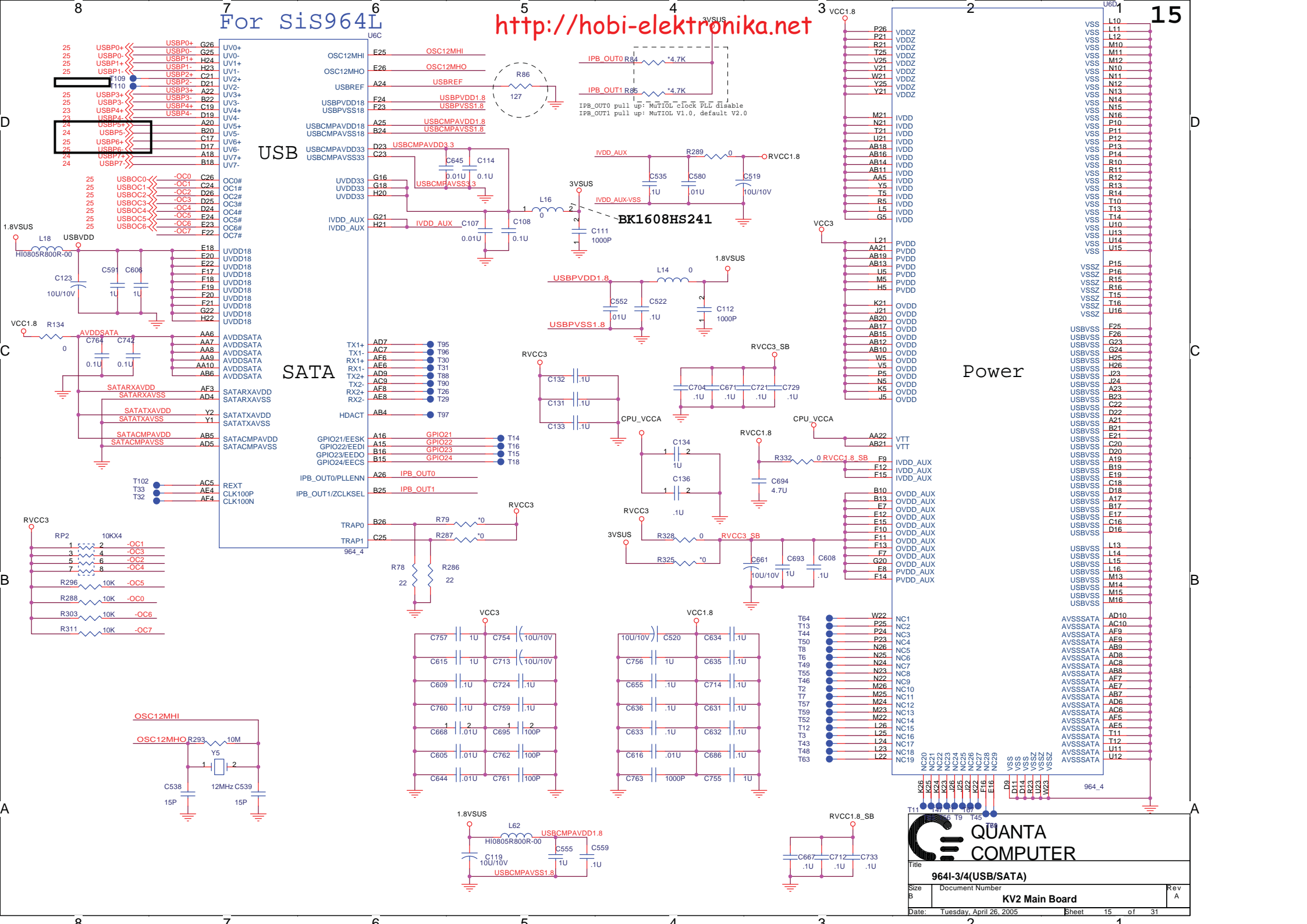

USB

SATA

Power

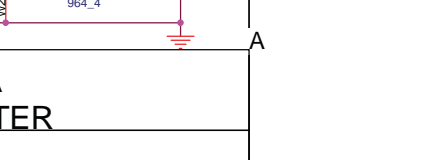
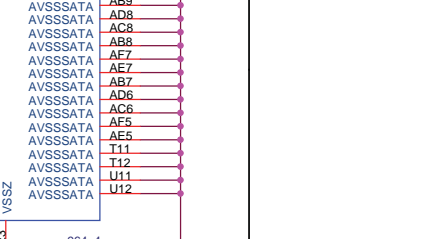
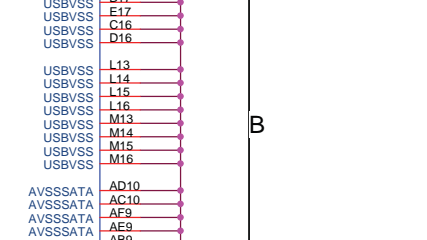
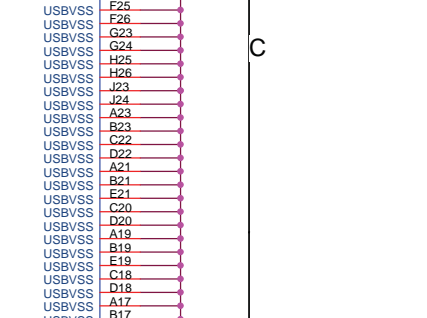
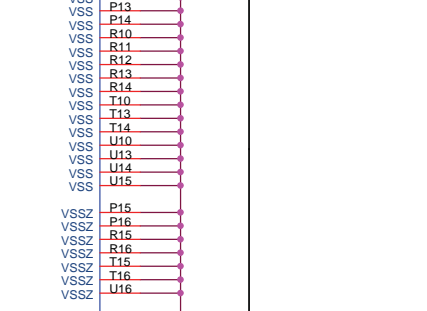
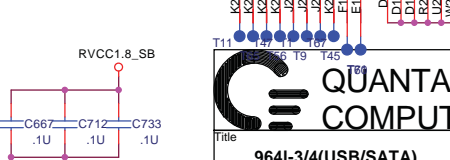
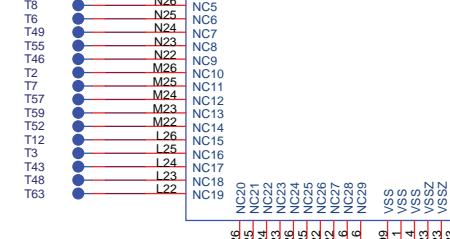
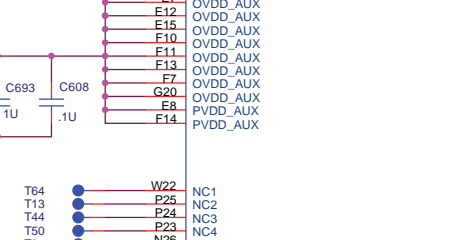
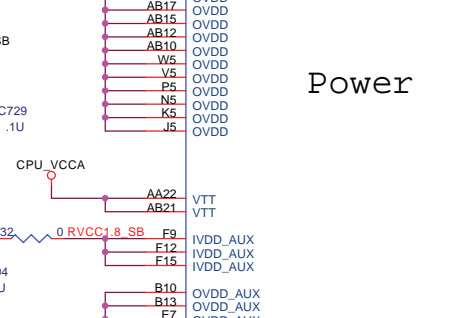
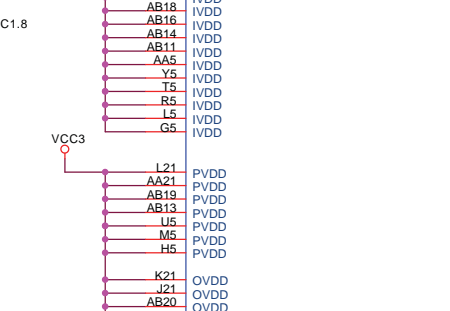
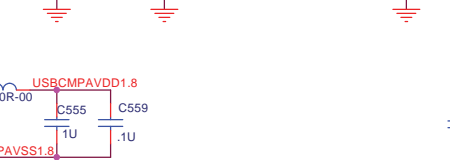
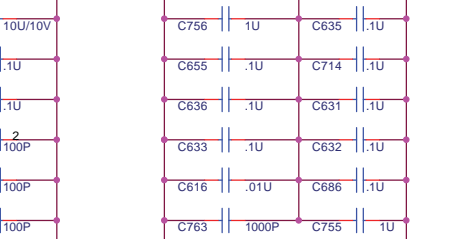
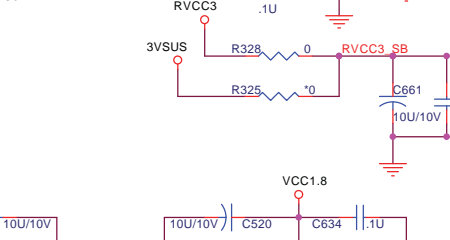
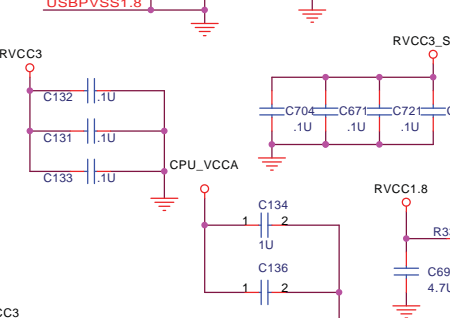
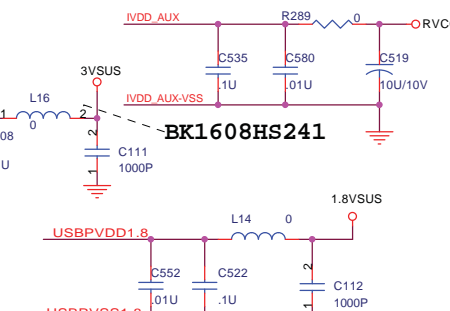
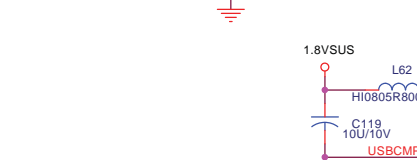
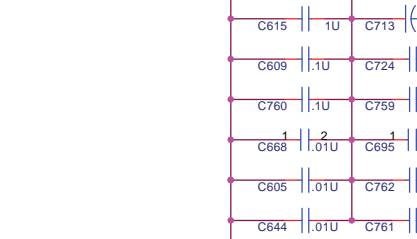
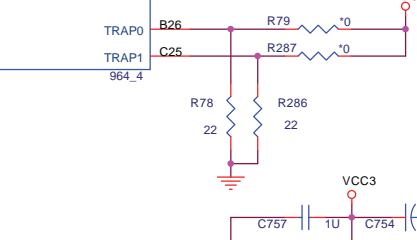
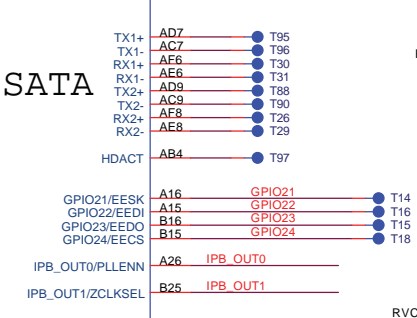
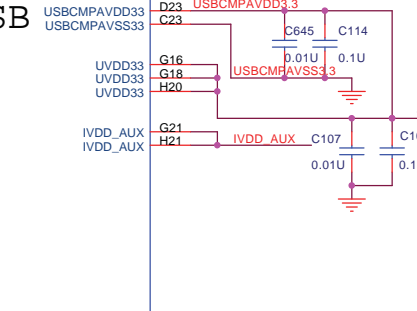
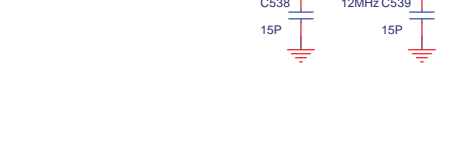
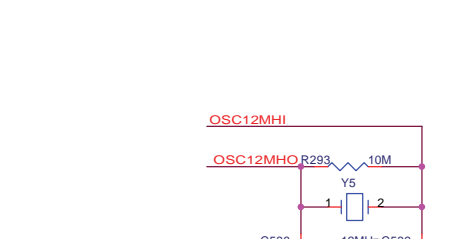
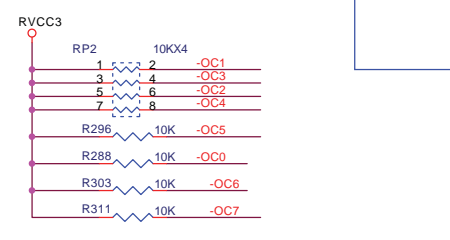
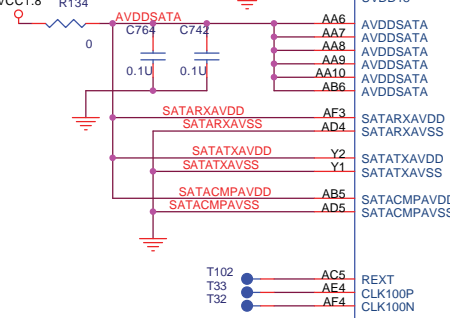
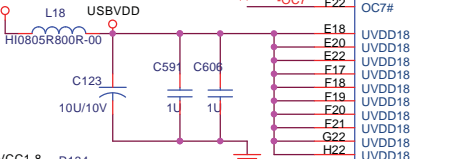
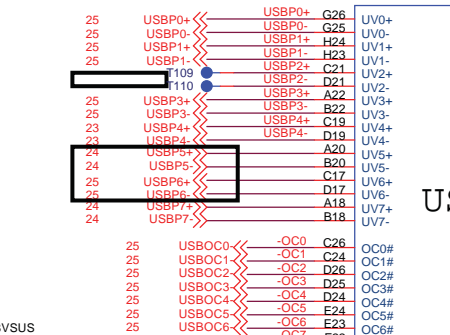

QUANTA COMPUTER

Title: **9641-3/4(USB/SATA)**

Size: Document Number

Sheet: **KV2 Main Board** of 31

Date: Tuesday, April 26, 2005

Thermal protect

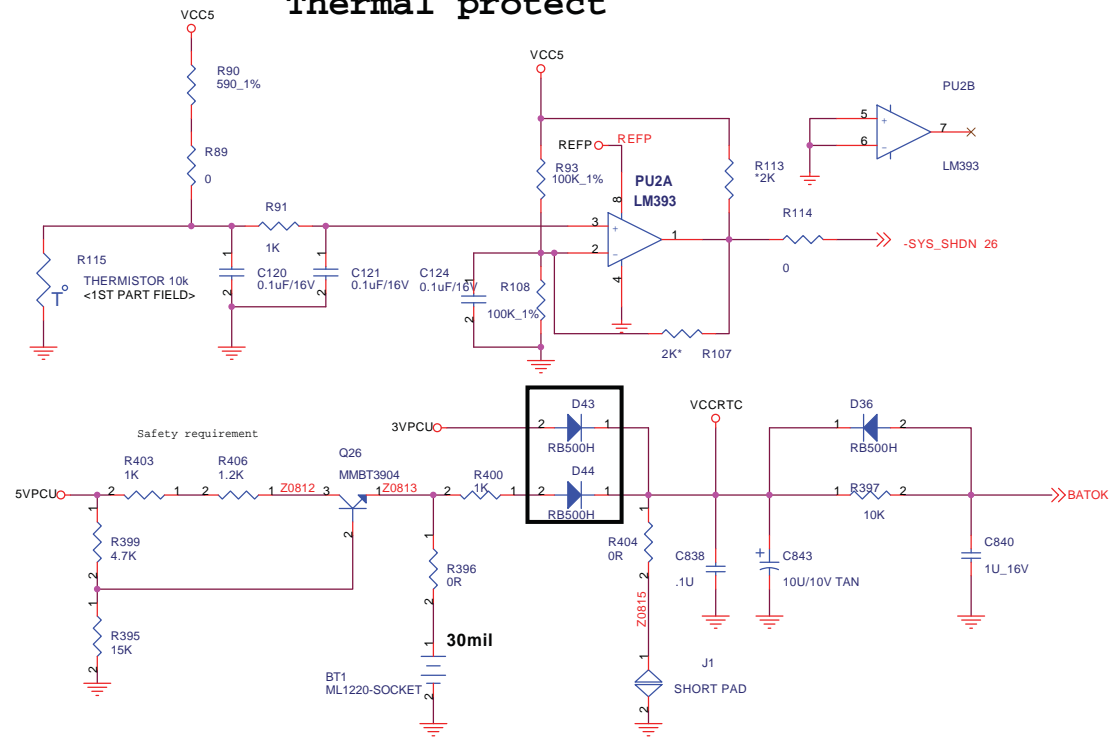

Thermal Sensor

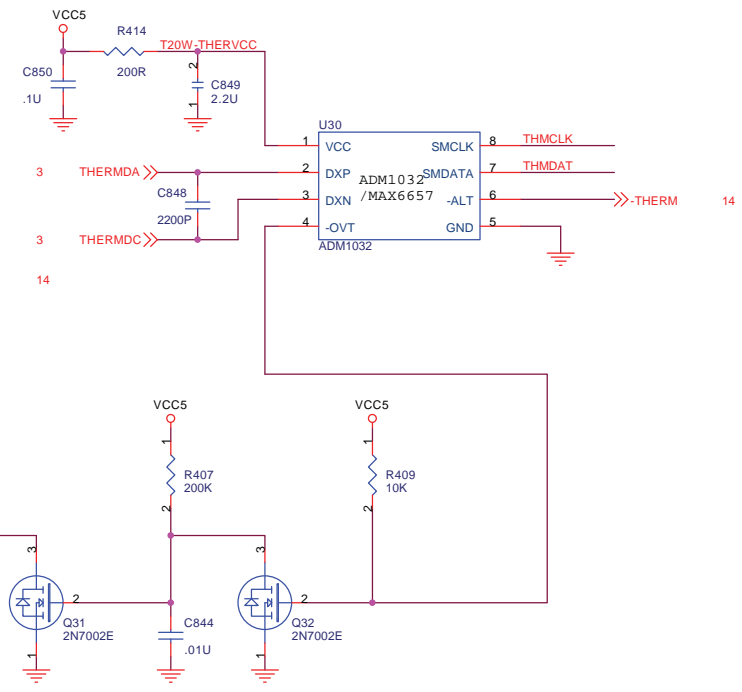

RTC Charger

Fan

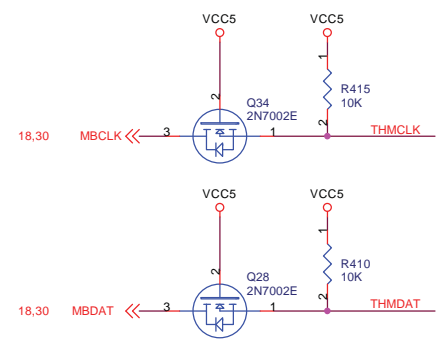
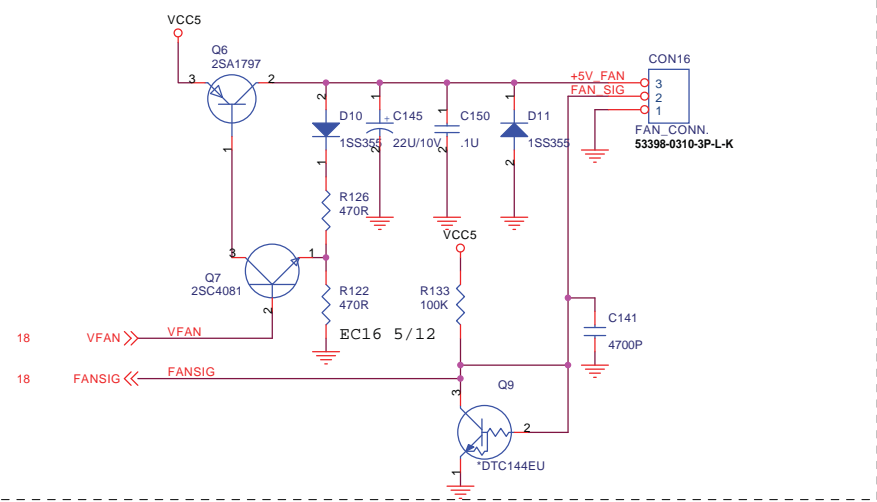

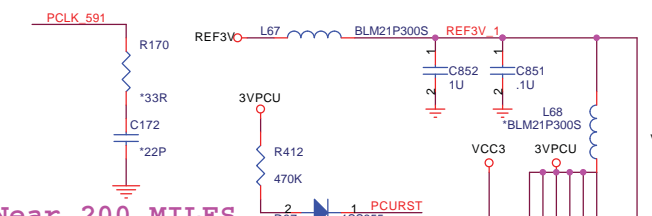

Near 200 MILES

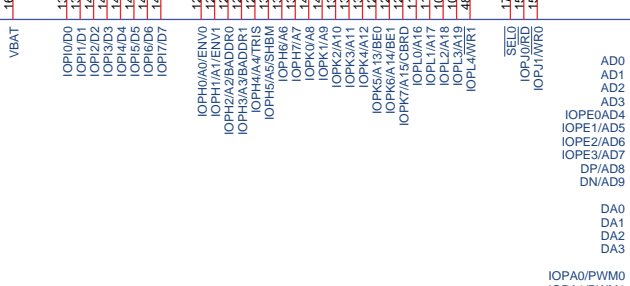
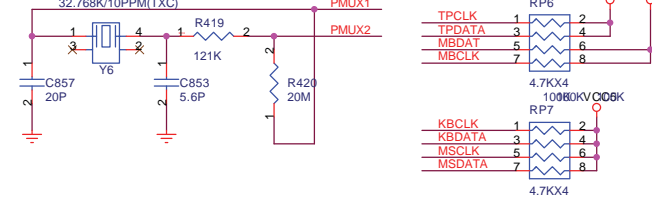
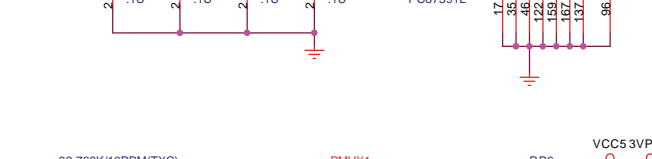
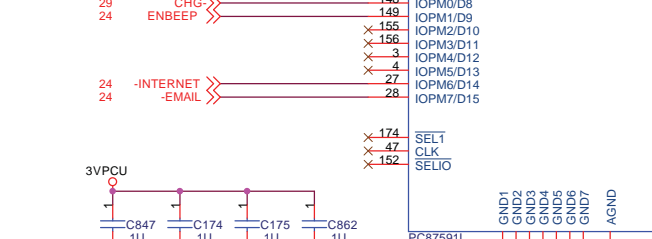
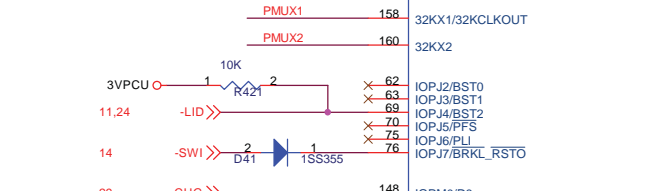
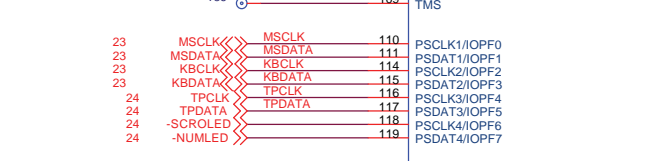
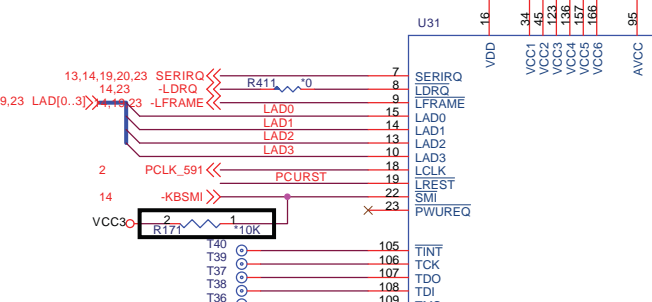

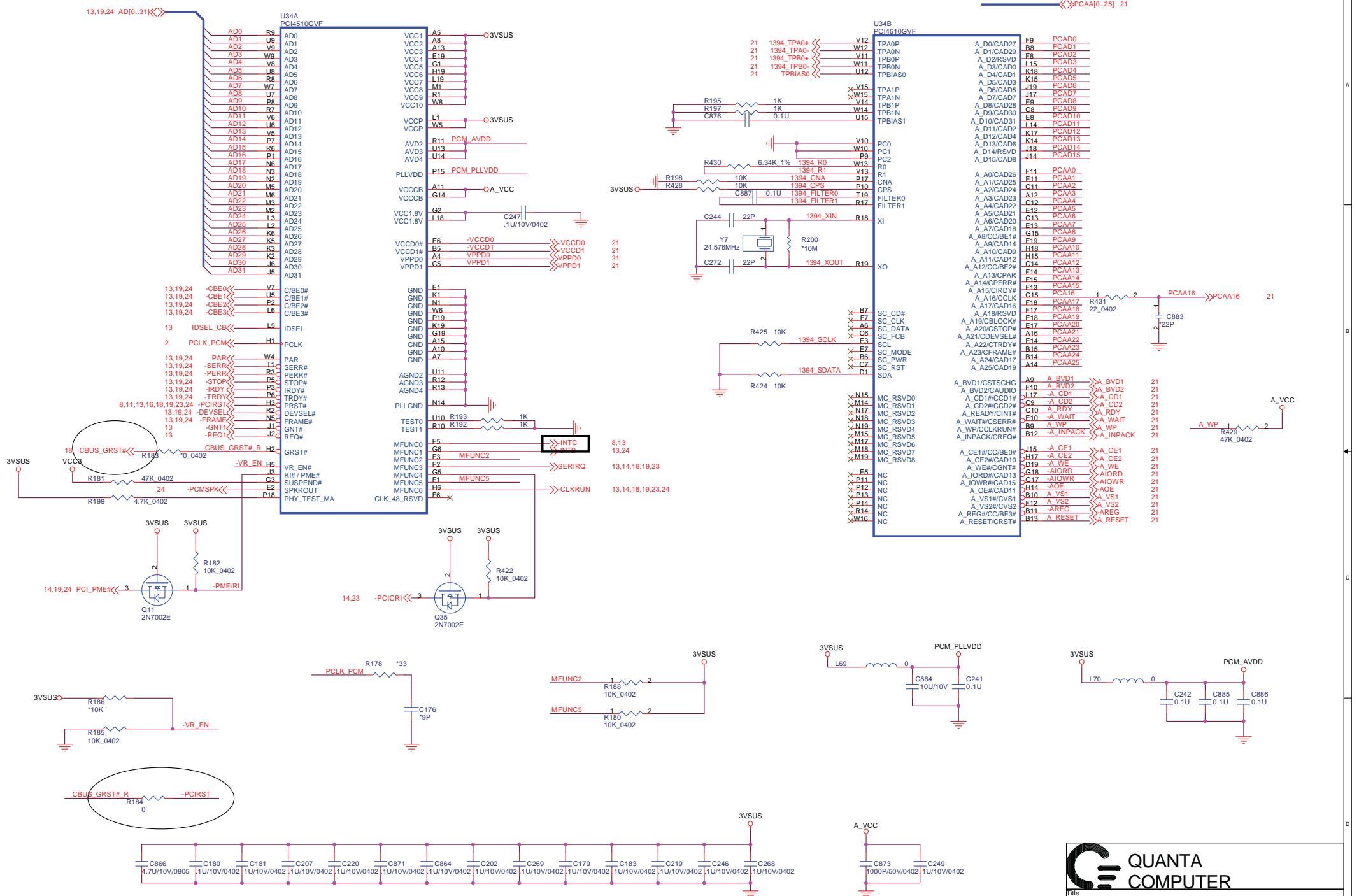

QUANTA COMPUTER

File: **PCI4510GVF**

Size: Custom Document Number: **KV2 Main Board** Rev: A

Date: Tuesday, April 26, 2005 Sheet: 20 of 31

PCMCIA POWER SWITCH

PCMCIA SOCKET

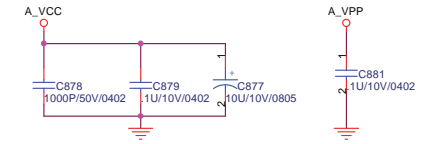
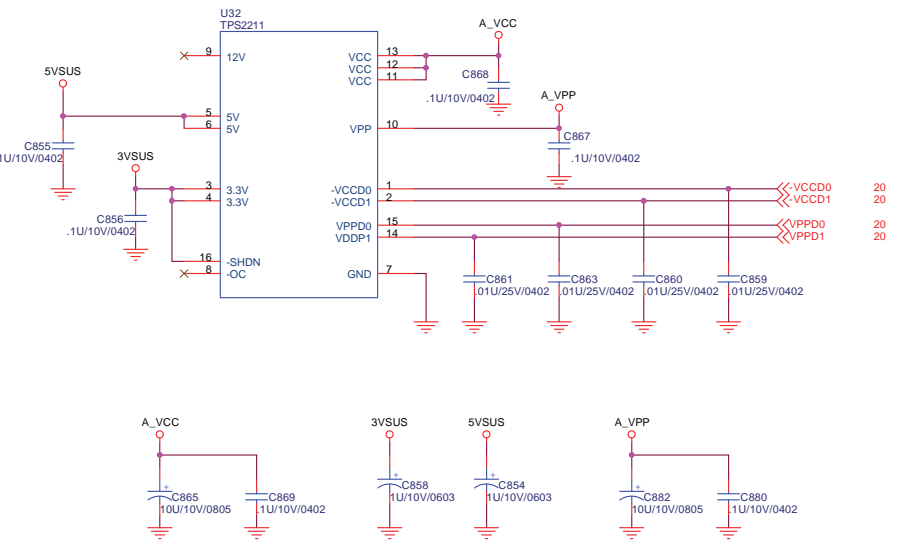

IEEE 1394 CONNECTOR

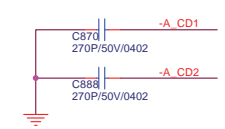
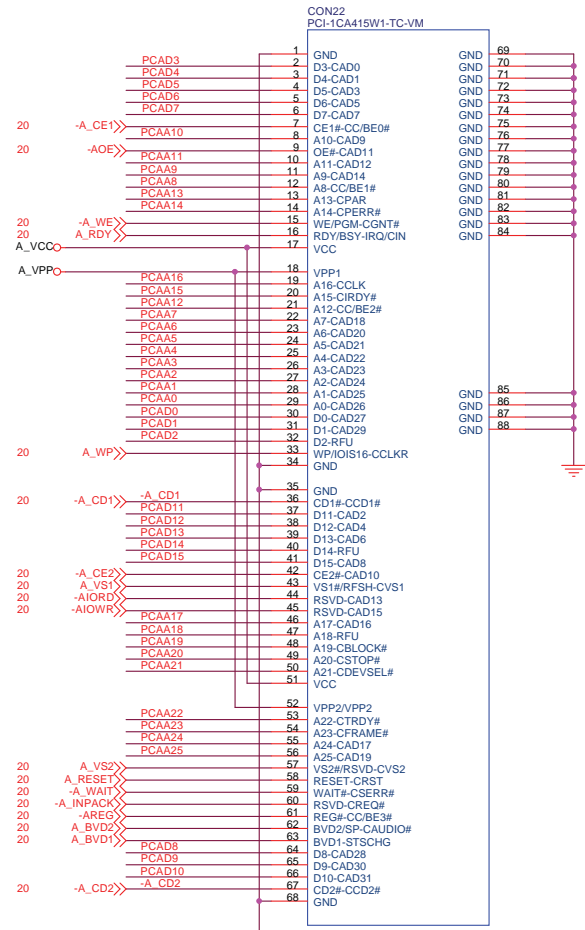
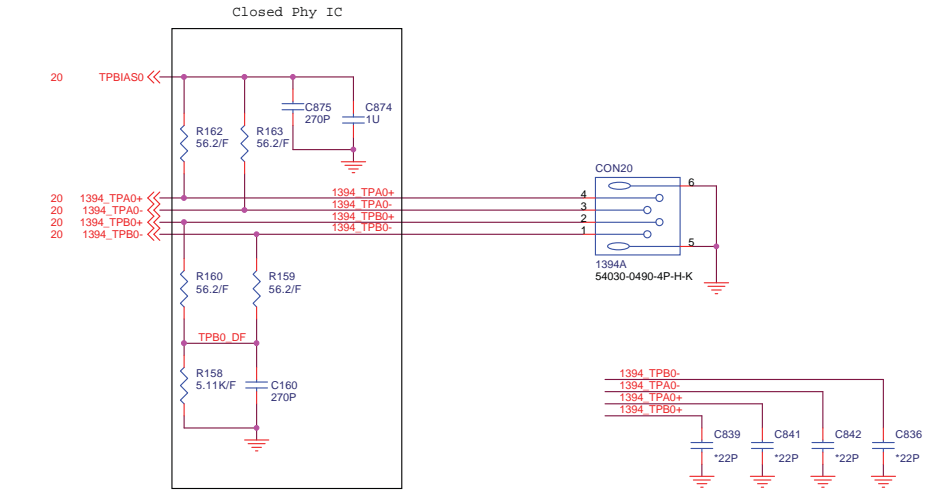

Change PCMCIA Conn.

QUANTA COMPUTER

Title: **PCMCIA SOCKET&POWER**

Size: Custom Document Number: **KV2 Main Board** Rev: A

Date: Tuesday, April 26, 2005 Sheet: 21 of 31

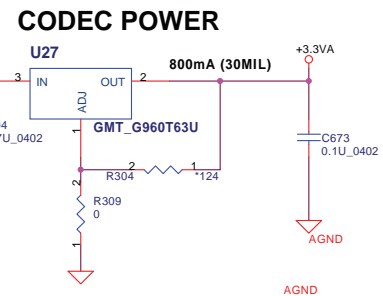
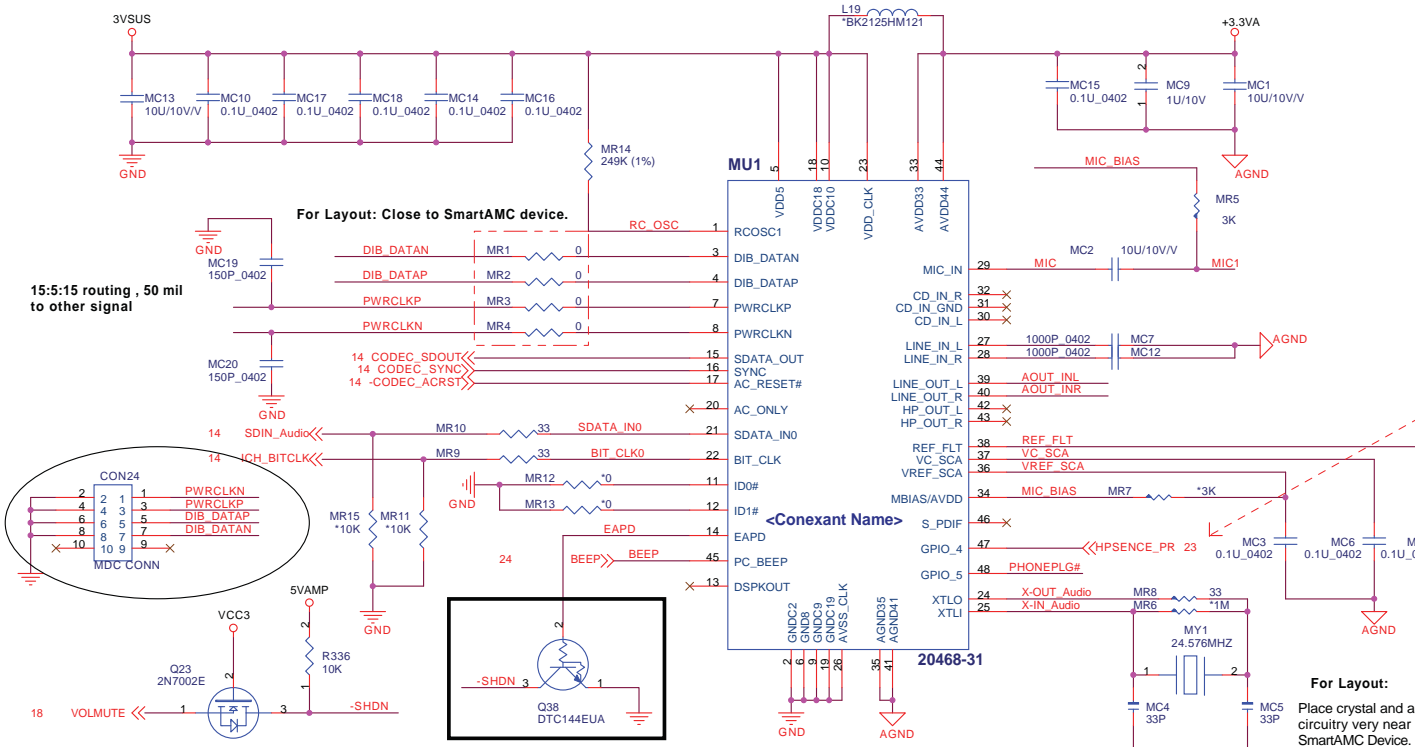

SOFTWARE EQ CONTROL TABLE

GPIO4	GOIO5	SW EQ
LOW	LOW	ON
LOW	HIGH	OFF
HIGH	LOW	OFF
HIGH	HIGH	OFF

SEL	FUNCTION
LOW	IN_B0
HIGH	IN_B1

AUDIO AMPLIFIER

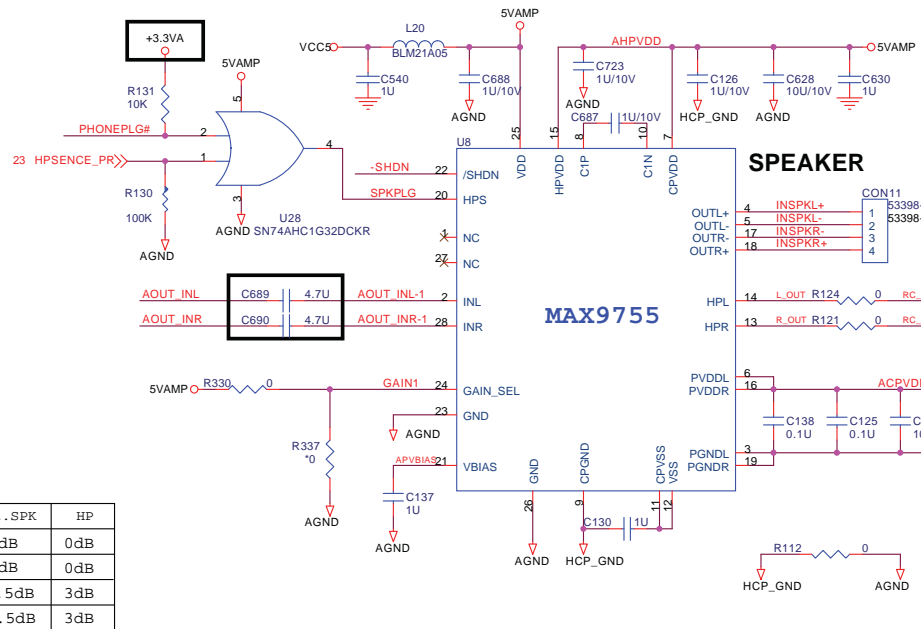

SPEAKER

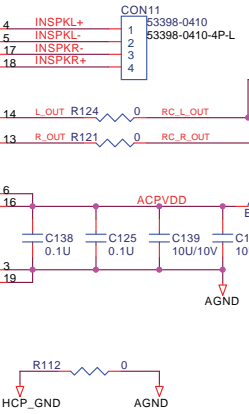

MIC

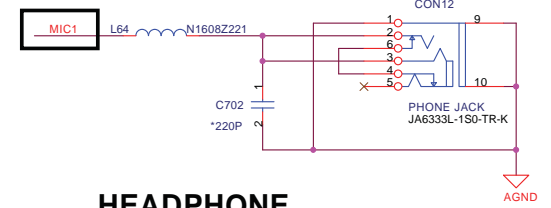

HEADPHONE

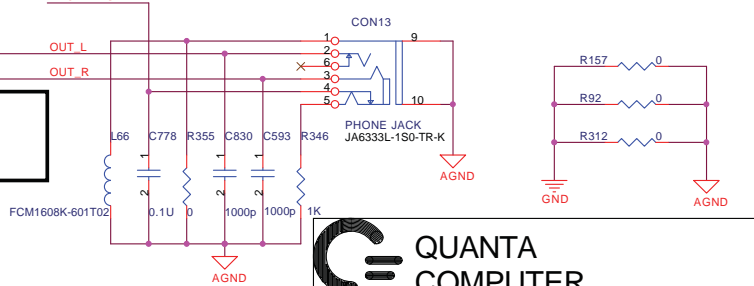

GAIN1	GAIN2	Int. SPK	HP
0	0	6dB	0dB
0	1	9dB	0dB
1	0	7.5dB	3dB
1	1	10.5dB	3dB

QUANTA COMPUTER

SmartAMC&

Size: Custom Document Number: KV2 Main Board

Date: Tuesday, April 26, 2005 Sheet 22 of 31

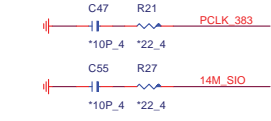
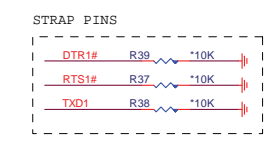
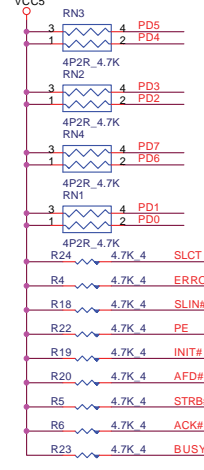
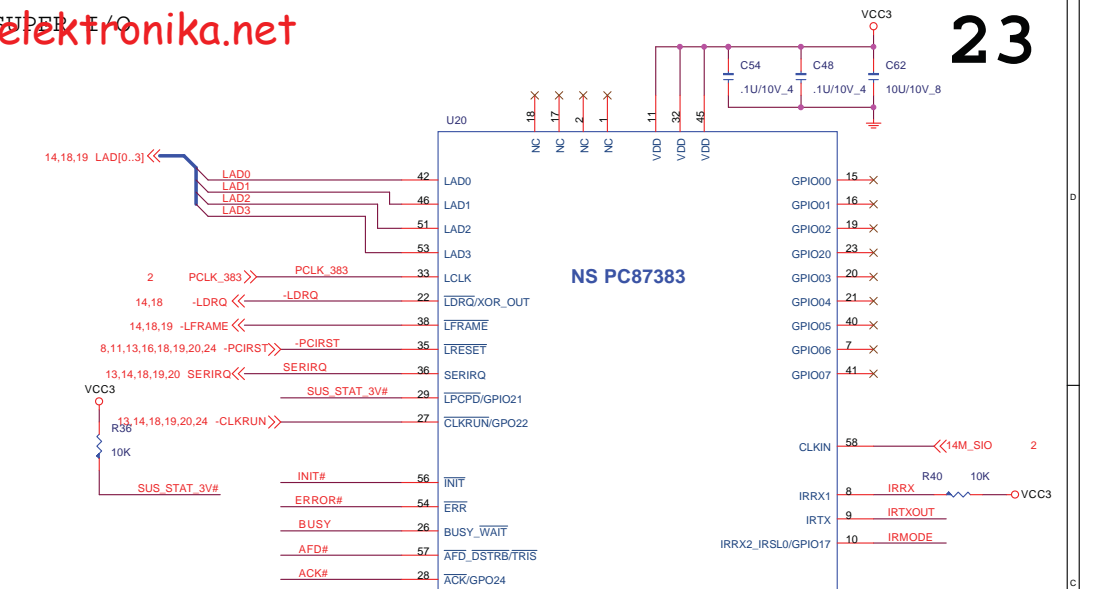
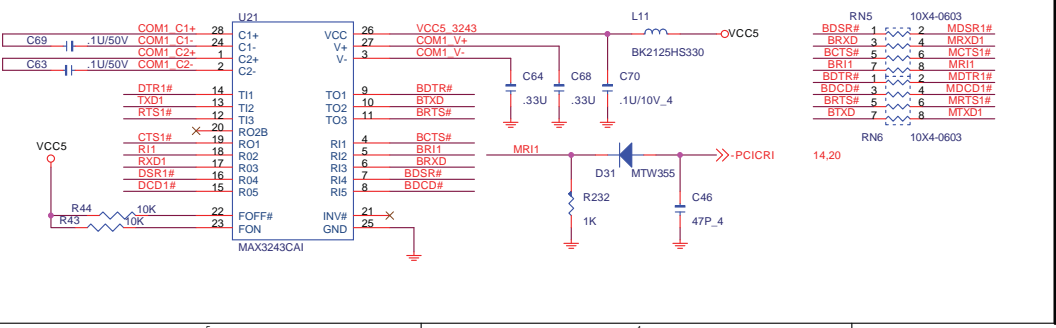
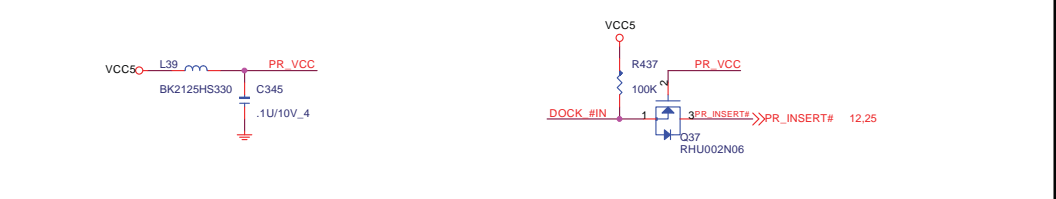
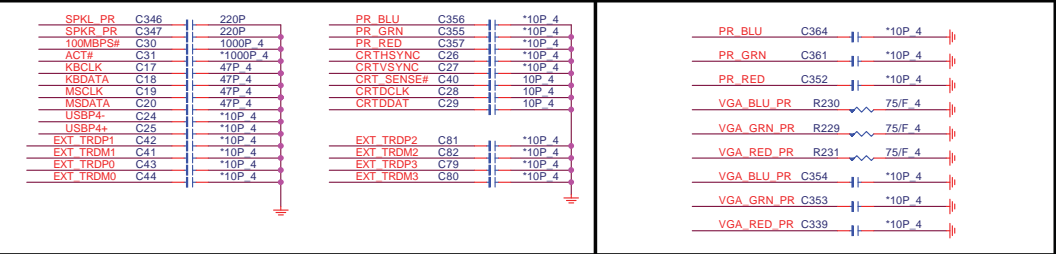
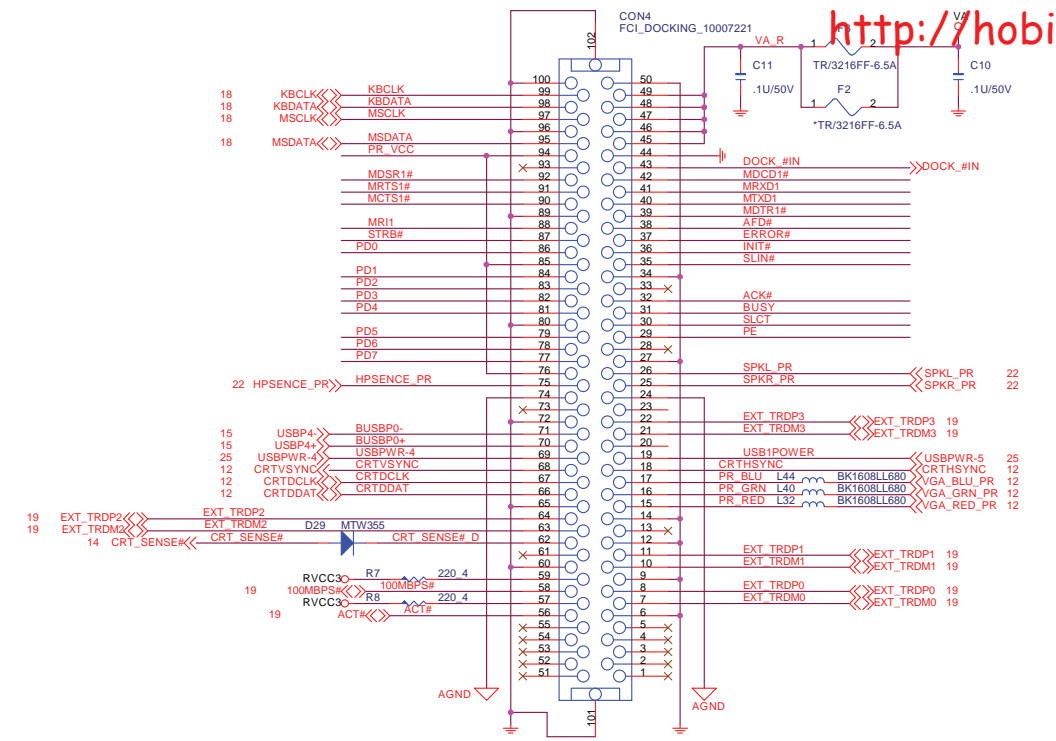

IrDA

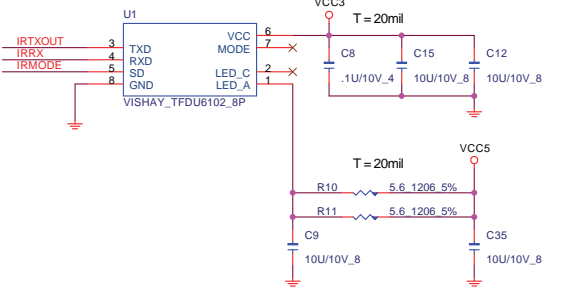

QUANTA COMPUTER

File: **EZ PORT & SIO**

Size: Custom Document Number: **KV2 Main Board** Rev: A

Date: Tuesday, April 26, 2005 Sheet: 23 of 31

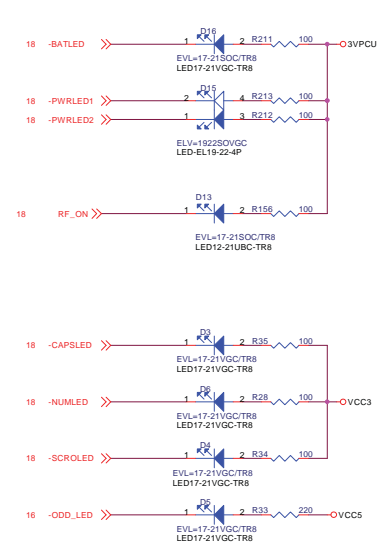
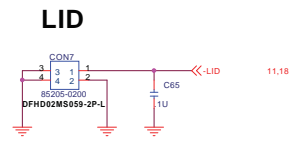
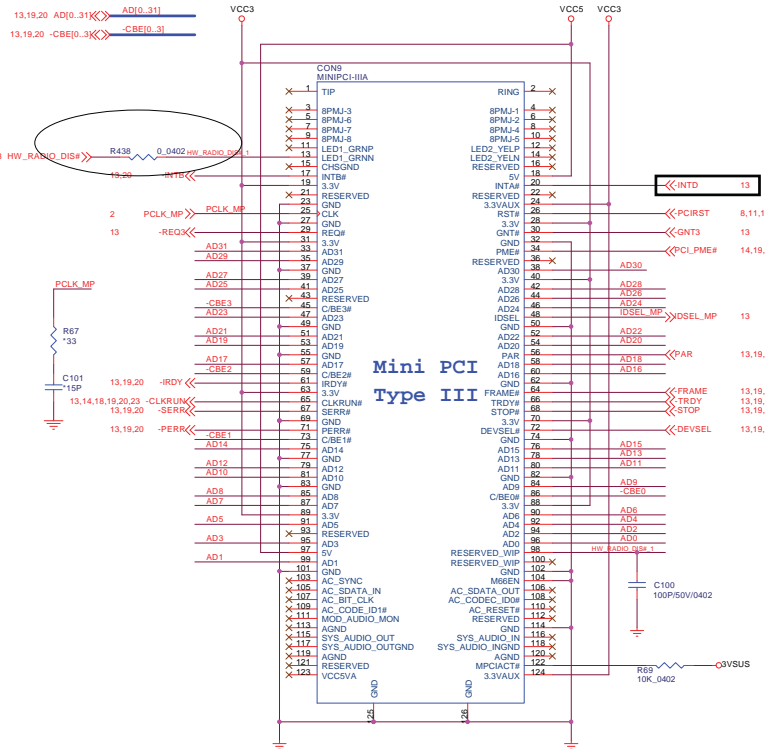

Int. keyboard

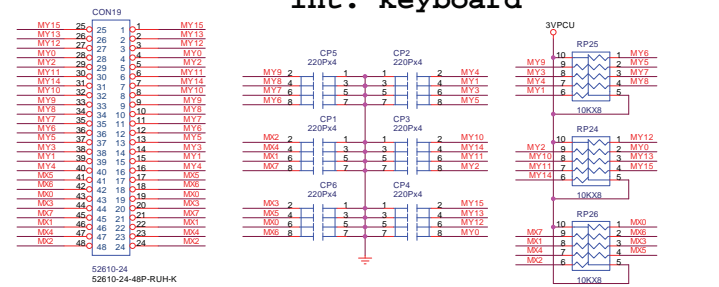

Bluetooth CON

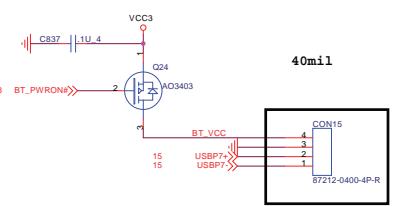

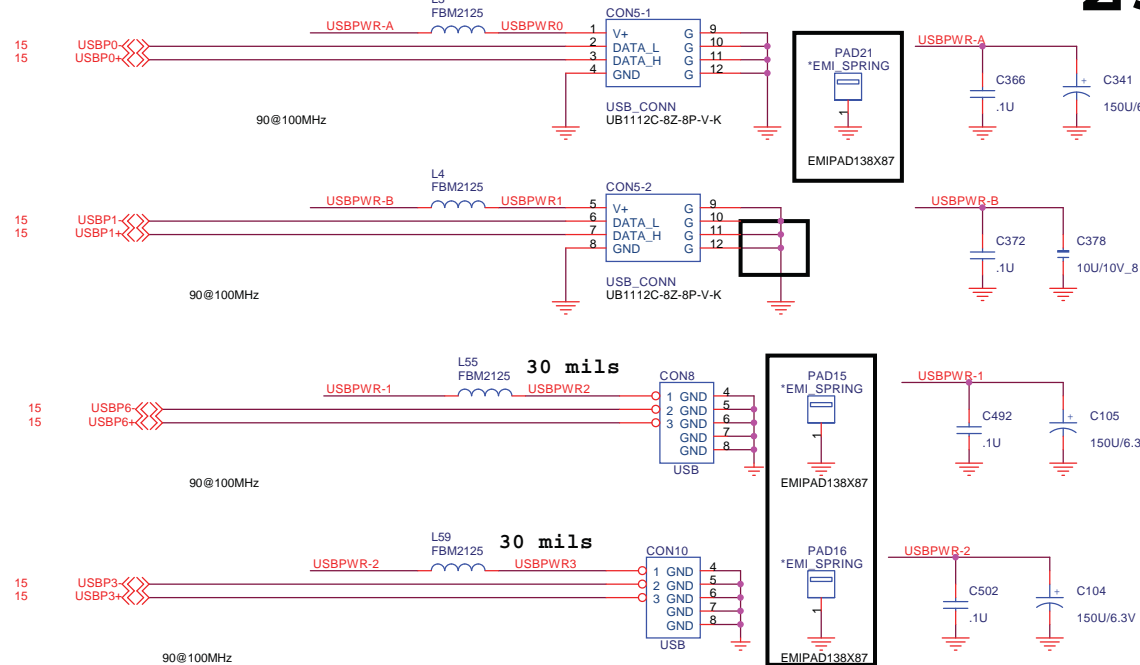
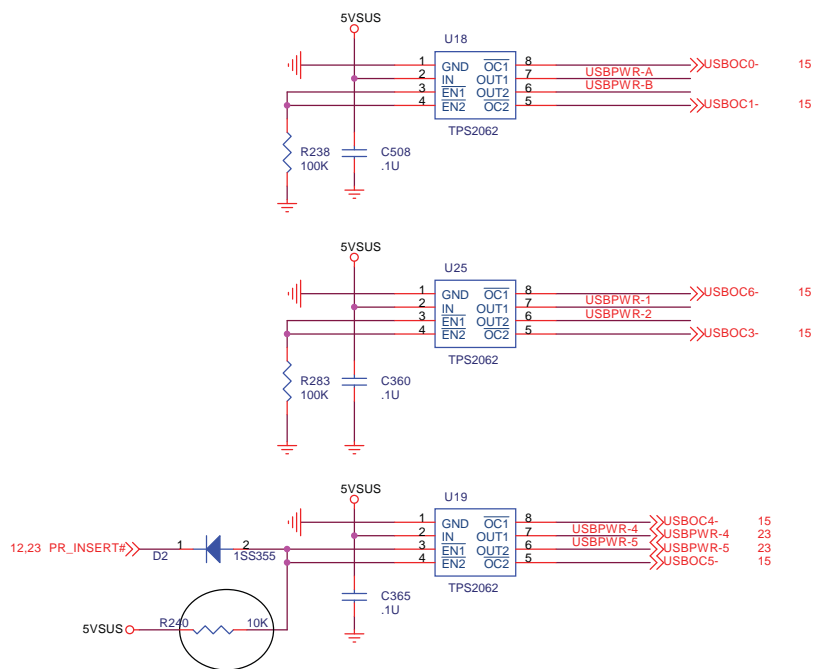

Screw

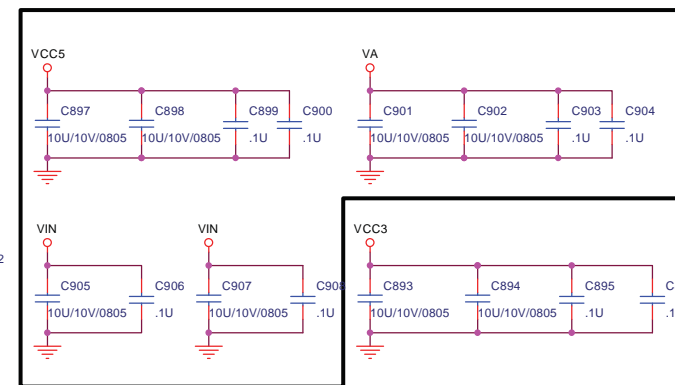
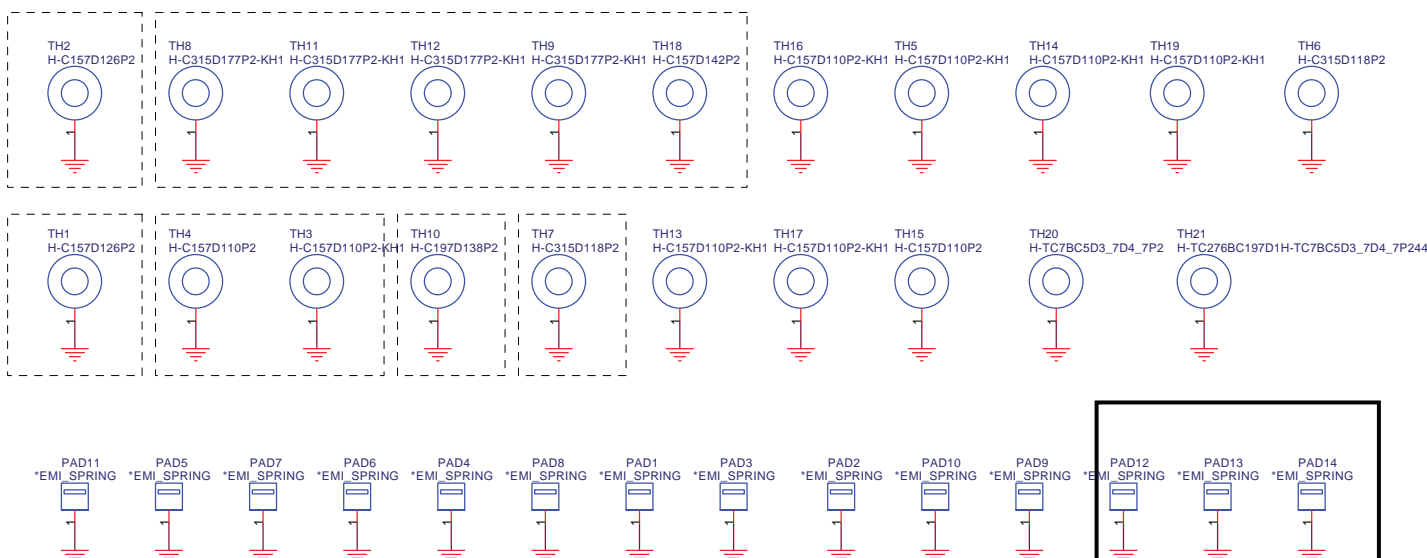

EMIPAD138X87 EMIPAD138X87 EMIPAD138X87 EMIPAD138X87 EMIPAD138X87 EMIPAD138X87 EMIPAD138X87 EMIPAD138X87 EMIPAD138X87 EMIPAD138X87 EMIPAD138X87 EMIPAD138X87 EMIPAD138X87 EMIPAD138X87 EMIPAD138X87 EMIPAD138X87



**QUANTA
COMPUTER**

Title: **USB4/SCREW**

Size A3	Document Number KV2 Main Board	Rev A
Date: Tuesday, April 26, 2005		
Sheet 25 of 31		

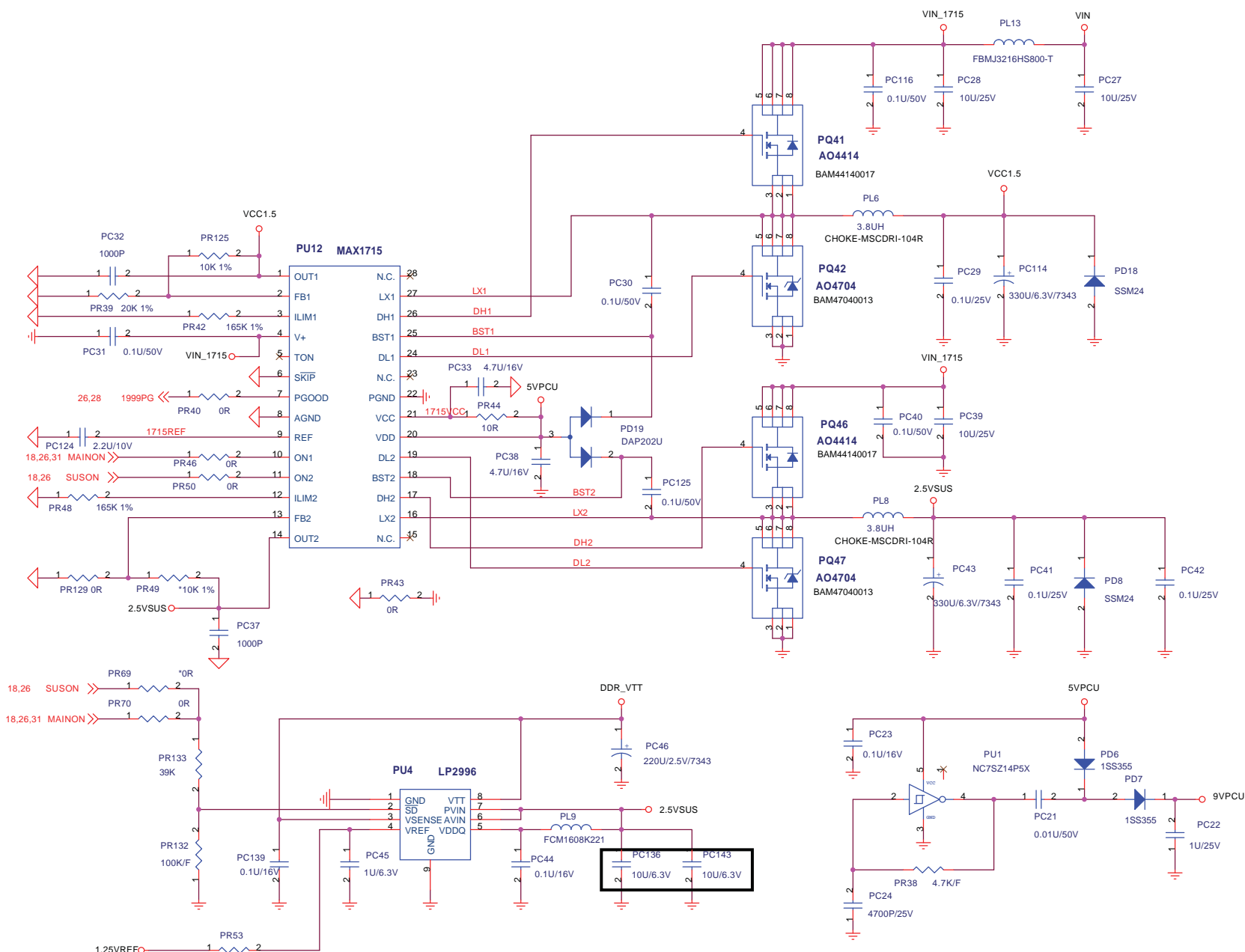

QUANTA COMPUTER

Title: **DC/DC 1.5V/2.5VSUS/DDR**

Size B Document Number: **KV2 Main Board**

Date: Tuesday, April 26, 2005 Sheet 27 of 31

CPU V_CORE

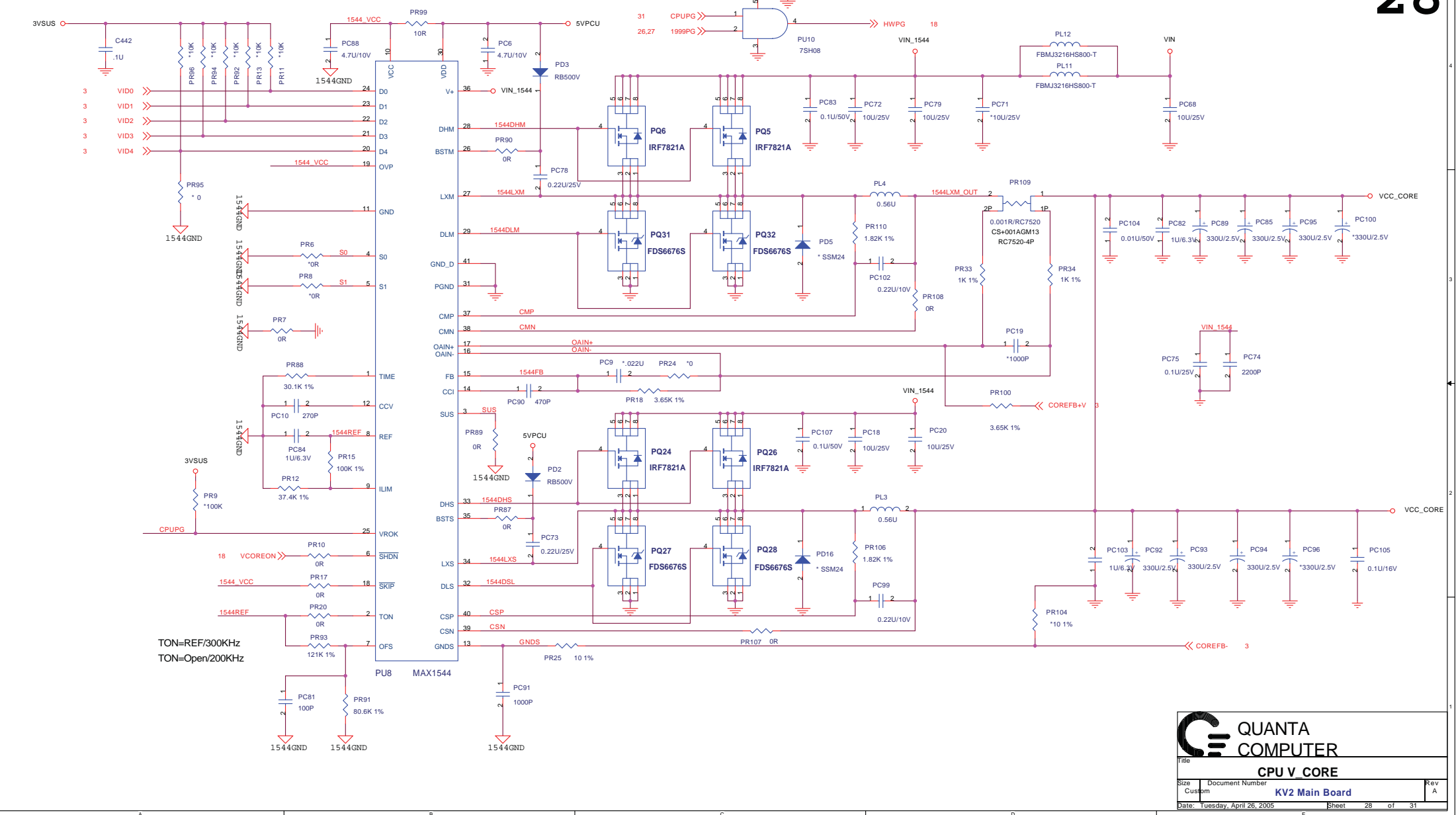

TON=REF/300KHz
TON=Open/200KHz

Title	
CPU V_CORE	
Size	Document Number
Custom	KV2 Main Board
Date: Tuesday, April 26, 2005	Sheet 28 of 31

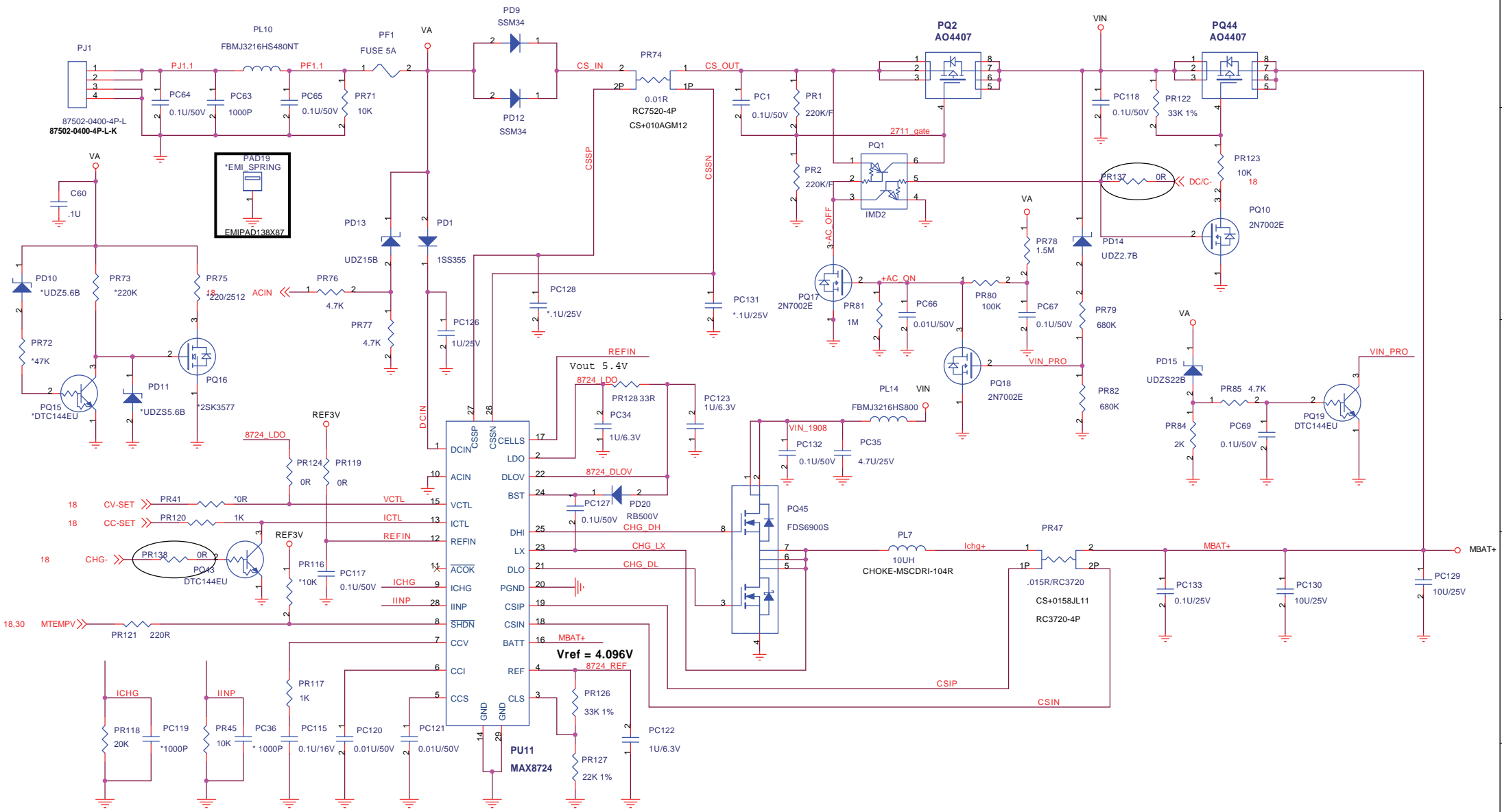

$ILIM = 4.096 / 4.096 * 75mV / 10mR = 7.5A. (140W)$

		QUANTA COMPUTER	
		Title BATTERY CHARGER	
Size A3	Document Number KV2 Main Board		Rev A
Date:	Tuesday, April 26, 2005	Sheet 29	of 31

Battery Connector

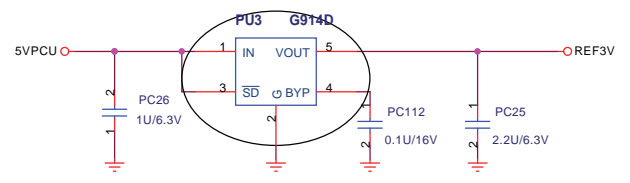
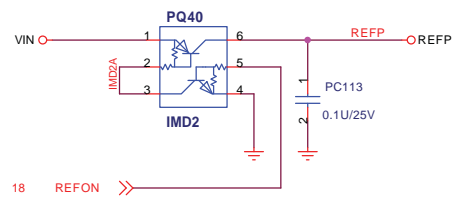
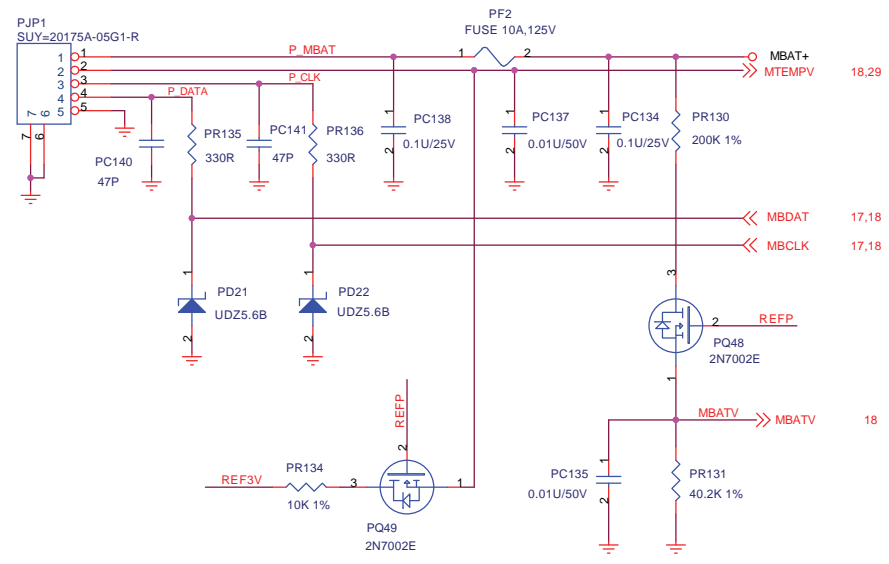

		QUANTA COMPUTER
Title BATTERY SELECTOR		
Size B	Document Number KV2 Main Board	Rev A
Date: Tuesday, April 26, 2005	Sheet 30 of 31	

